

Buffer Bow Design for the Improved Safety of Ships

Ou Kitamura (V), Nagasaki R&D Center, Mitsubishi Heavy Industries, Ltd., Japan

ABSTRACT

The results of the previous research project in Japan, which was carried out by the Association for Structural Improvement of the Shipbuilding Industry (ASIS) during 1991-1997, suggested that; 1) The double hull regulation led to the improved crashworthiness of large tankers but the safety has not yet been guaranteed to a satisfactory level in the case of high-energy collision accidents. 2) Further reinforcement of the side structure of large tankers is possible but the shipping, shipbuilding and other parties concerned may hesitate over the voluntary action because of the required cost impact. 3) Buffer bow design adopted to the colliding ship may be advantageous from both desirable results and reasonable cost points of view. Following the ASIS research project, design alterations to the form and stiffening system of a bulbous bow have been studied intensively within the RR76 panel of the Shipbuilding Research Association of Japan (JSRA). In the present paper, the quantitative target of the energy to be absorbed by the structural damage and the estimated ultimate strength and energy absorption capability of both ordinary and buffer bows are discussed based on the results of the finite element collision simulations. In conclusion, the effectiveness of the buffer bow design is emphasized.

1. INTRODUCTION

Because of the disastrous oil spills due to tanker groundings and collisions around 1990, the double hull (D/H) design of tankers has become the de facto standard for the preservation of the marine environment against oil pollution. However, recent research on the structural response in collision has demonstrated that the crashworthiness of D/H tankers is still not improved to the satisfactory level in the case of high energy collision accidents (Kitamura 1997, 1998 and Paik et al. 1999). Roughly speaking, the colliding speeds of large ships critical to large D/H tankers are estimated to be 10 knots, depending on the underlying assumptions. This point is supported by accounts of serious damage sustained by the side structure of ships involved in collisions. Figure 1-1

shows the heavy damage to the single side and longitudinal bulkhead structures of a Suezmax tanker collided with a VLCC in ballast condition in 1997. Figure 1-2 shows the breached double side structure of a 4200TEU class large container ship collided with a passenger ship in 1999.

On the other hand, voluntary reinforcement or design alteration to the double side structure and/or increased subdivision of cargo tanks beyond the requirements of the current regulation may be unattractive to everyone concerned because of their unsatisfactory cost efficiencies when compared with the collision accident statistics (Kitamura et al. 1998 and Paik et al. 1999). Besides the implementation of International Safety Management (ISM) Code and Automatic Identification System (AIS) can further reduce the collision risk in the near future.



Fig.1-1 A Suezmax tanker collided with a VLCC



Fig.1-2 A container ship collided with a passenger ship

As mentioned above, drastic improvements in the tanker design is hardly expected, whereas there is still free scope for the intentional design alteration to the bow structure of potential colliding ships (Woisin 1976 and Kitamura et al. 1998). As a matter of course, any structural design alteration to the colliding ship is given advantage in cost aspect because such measures for the protection of struck tanker can practically be limited only to the bow region. Moreover, it is anticipated that those can be adopted immediately based on the conventional design and construction technologies.

In 1998, oil-spill prevention working group was organized in the regulation research panel No.76 (**RR76**) of the Shipbuilding Research Association of Japan (**JSRA**). This follows the results of 7-year research project carried out by the Association for Structural Improvement of the Shipbuilding Industry (**ASIS**) supported by the Ministry of Transport. In RR76 panel reviewed the development of collision-buffering bow (**Buffer Bow**) designs, simplified analytically based prediction method (Suzuki et al. 1999), as well as a series of finite element collision simulations. This paper presents a summary of the finite element collision simulations.

2. BUFFER BOW DESIGN APPROACH

In the ASIS research project, buffer bow designs were first calculated for their energy absorption capabilities and damage protection performance (Kitamura et al. 1998). The original buffer bow design in 1996 was characterized by a bumper forehead above waterline and blunt-formed bulbous bow under waterline as shown in figure 2-1. The bulbous bow was formed with non-tight shells and stiffened with vertical ring frames in order to reduce the axial crushing rigidity to the minimal level.

Generally speaking, the crushing strength of the buffer bow must be smaller than that of side structure of a struck ship, while the energy absorption capability of the bow is to be kept as large as possible to increase total energy absorption capability. From more practical and optimal standpoints, the present investigations have been concentrated to rather conservative and conventional design of blunt-formed bulbous bow which is plated with watertight shells and stiffened with vertical ring frames in the study of RR76 panel. The effects of the bow form, stiffening system and the advance speed of a struck ship are the major concerns to be discussed.

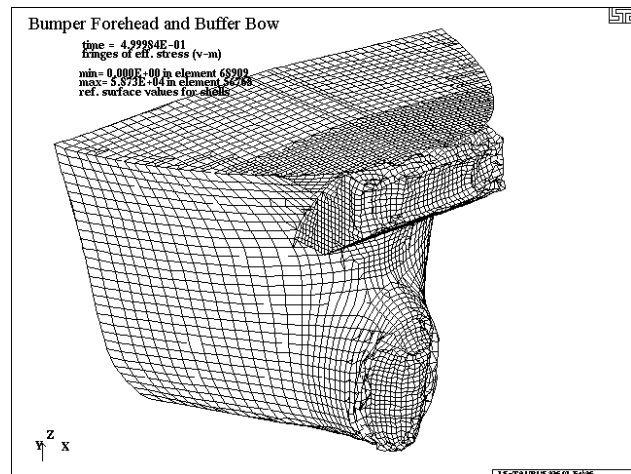

Fig.2-1 Original buffer bow idea -- crushing (ASIS, 1996)

3. FINITE ELEMENT COLLISION SIMULATIONS

3.1 Simulation Code

A numerical simulation system customized for the prediction of the structural damage to ships during the collision or grounding accident was adopted. The simulation system was developed in the ASIS research

project (Kuroiwa et al. 1995). Subroutines to judge the rupture of steel plates and failure of welds were integrated to the general-purpose explicit finite element core code “LS-DYNA”. A subroutine to calculate the rigid body motion of ships (6-degrees of freedom) was also coupled with the stepwise analysis of the structural response. The reliability of the numerical simulation system has been verified by many large-scale experiments (Vredeveltdt & Wevers 1992 and Kitamura et al. 1998). The finite element numerical approach is powerful, however, it must be noted that the following aspects are still not considered due to the computation capability limit and uncertainties.

- 1) Local structural response affected by quasi-static or dynamic direct loads such as internal cargo oil and/or external seawater pressure
- 2) Coupling of local structural response with hull girder global bending response (briefly discussed in 4.)
- 3) Deterioration of the structure in service, such as corrosion

3.2 Simulation Model

Port side midship tank structure of a D/H VLCC was modeled by elasto-plastic finite elements. The remaining parts, i.e., starboard side, forward and aftward of elasto-plastic finite element model were modeled by rigid elements to represent her hull form. The width of double side space is about 3.4 m and the primary transverses are arranged at intervals of about 4.2 m. The standard size of a finite element at side shell is about 700 mm * 480 mm. Mesh patterns in way of oiltight and swash bulkheads are made more coarsely.

Bow structures of colliding ships were also modeled by elasto-plastic finite elements as shown in Figures 3.2-1 through 3.2-8. The remaining structure, aftward of the elasto-plastic finite element model, was modeled by rigid elements that represented the hull form. The standard size of a finite element at side shell is about 200 mm * 200 mm. Total numbers of elements adopted are listed in Table 3.2-1.

Table 3.2-1 Number of Elements

		ShellElements	BarElements	Total
SuezmaxTanker	Standard-BluntBow	34709	8526	43235
	Buffer-BluntBow	25524	8017	33541
	Standard-SharpBow	24547	7764	32311
6200TEU Container Ship	Standard-SharpBow	60478	9343	69821
	Buffer-SharpBow	58410	9303	67713
D/H VLCC	StandardDouble Side	48668	17506	66174

The profile view of a Suezmax tanker having sharp-formed bulbous bow is shown in figure 3.2-1. Figure 3.2-2 shows a standard structural arrangement of sharp-formed bulbous bow stiffened with side longitudinals, which are supported by primary transverses. A Suezmax tanker having sharp-formed bulbous bow stiffened with side longitudinals is identical to that adopted in the ASIS research project. However in the present collision simulations, her model is re-meshed with half-size elements in order to increase the reliability. Because a Suezmax tanker is a slow speed ship with a full hull form, the sharpness is not so obvious compared to that of a speedy container ship as shown in figure 3.2-6.

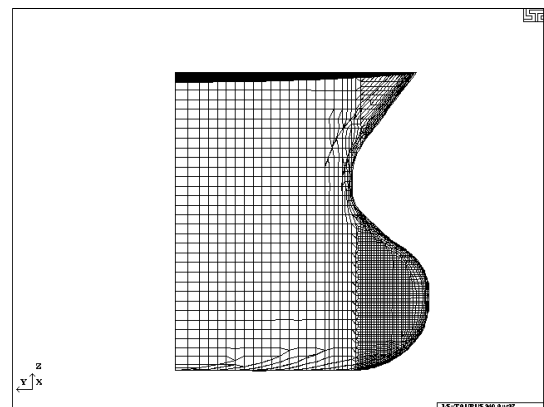

Fig.3.2-1 Sharp-formed bulbous bow (Suezmax tanker)

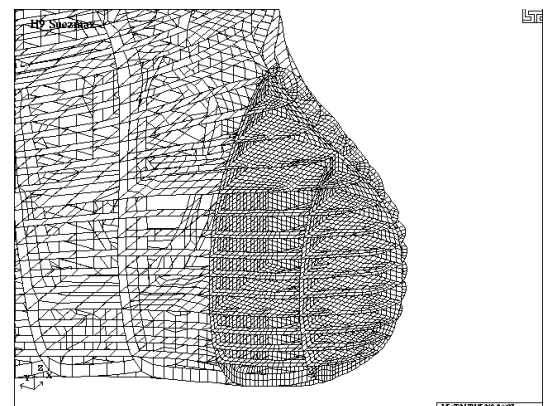

Fig.3.2-2 Standard-Sharp Bow (Suezmax tanker)

Figure 3.2-3 shows the profile view of a Suezmax tanker having blunt-formed bulbous bow. Figure 3.2-4 shows the standard structural arrangement of bulbous bow stiffened with side longitudinals, which are supported by primary transverses. Figure 3.2-5 shows the alternative buffer structural arrangement. Bulbous bow is stiffened with vertical ring frames supported by primary stringers.

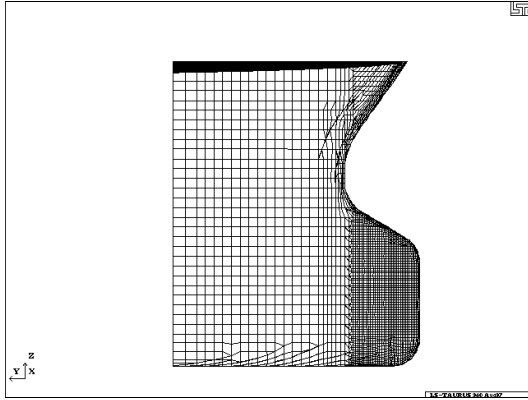

Fig.3.2-3 Blunt-formed bulbous bow (Suezmax tanker)

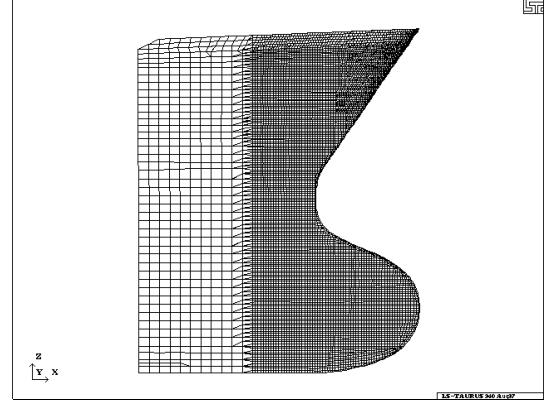

Fig.3.2-6 Sharp-formed bulbous bow (Container ship)

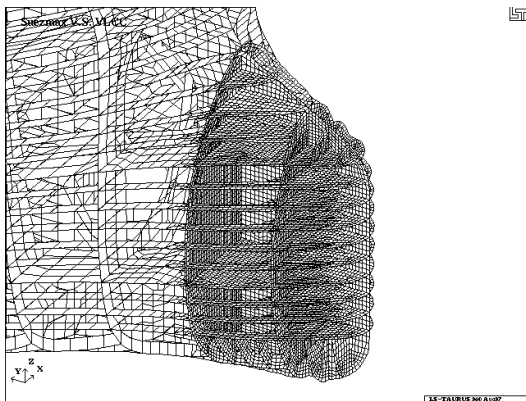

Fig.3.2-4 Standard-Blunt Bow (Suezmax tanker)

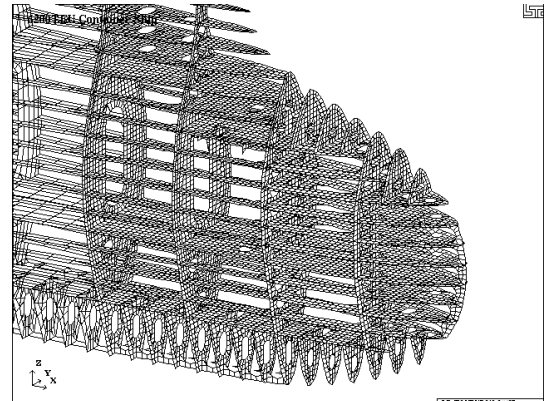

Fig.3.2-7 Standard-Sharp Bow (Container ship)

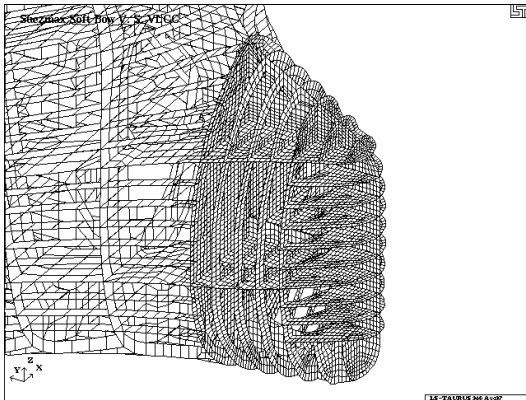

Fig.3.2-5 Buffer-Blunt Bow (Suezmax tanker)

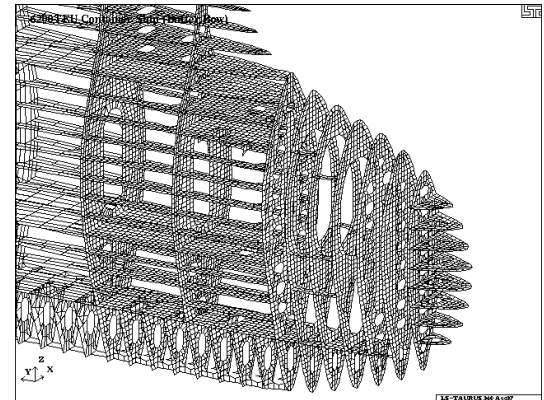

Fig.3.2-8 Buffer-Sharp Bow (Container ship)

Figure 3.2-6 shows the profile view of a super container ship of 6200 TEU class having sharp-formed bulbous bow. Figure 3.2-7 shows the standard structural arrangement of bulbous bow stiffened with side longitudinals, which are supported by primary transverses. Figure 3.2-8 shows the alternative buffer structural arrangement. A part of bulbous bow is stiffened with vertical ring frames supported by primary stringers.

The mesh pattern adopted to each finite element model is equivalent to that adopted to the model of a Suezmax tanker having sharp-formed bulbous bow (figure 3.2-1) to unify the comparison basis.

Mass and inertia including added mass of external seawater were defined at the center of gravity of each colliding ship and a D/H VLCC. Due to the limited extent of elasto-plastic finite element modeling and

adopted simplification in motion analysis, no coupling of structural response with hull girder global bending response can be analyzed. However, the coupling effect may not be significant as referred in the discussion.

The elasto-plastic finite elements are subject to the deformation according to the stress-strain relationship for the steel material which is shown in Figure 3.2-9. The elements are torn off when the equivalent plastic tensile strain reaches the threshold value which is defined in Figure 3.2-10.

Shell plates, decks, side stringers, side transverses and side longitudinals are modeled to separate from one another when the working stress level at fillet welds reaches the breaking criterion. Strain rate effect on yield point is considered based on Cowper-Symonds expression.

Constant friction coefficient of 0.3 between steels is also assumed throughout the simulation. A comparative collision simulation was performed assuming friction coefficient of 0.1 separately.

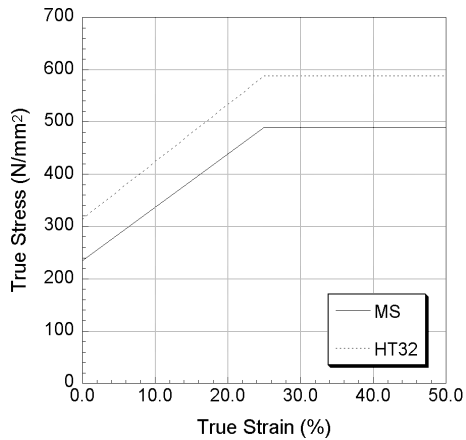

Fig.3.2-9 Assumed stress-strain relationship

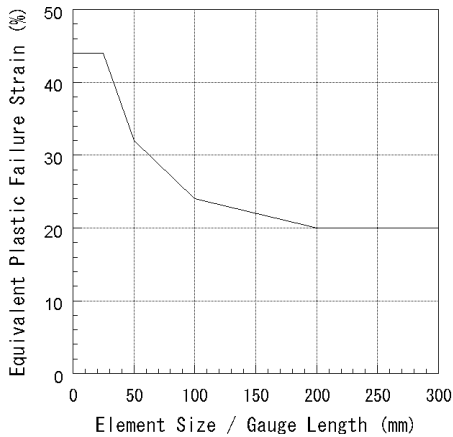

Fig.3.2-10 Assumed equivalent plastic breaking strain

3.3 Assumed Collision Scenario

Both colliding ships and struck ship (a D/H VLCC) are assumed to be navigating at 12 knots. The advance speed of 12 knots is de facto maximal speed in the straits and harbor where collision accidents are most likely to occur. The assumption of a struck ship being at standstill is unrealistic, however, additional collision simulations were performed with the identical D/H VLCC being at standstill in order to make the effect of the advance speed of a struck ship clear. It is assumed that each colliding ship is in ballast condition and collides with midship of a D/H VLCC in laden condition by right angle of 90 degrees as shown in Figures 3.3-1 through 3.3-4. According to the results of the ASIS research project, the critical speed required to rupture the inner hull, i.e. tank boundary, is a little higher when a colliding ship is in a laden condition, in spite of its greater kinetic energy. The initial collision point is located at mid-length between transverse oiltight and swash bulkheads.

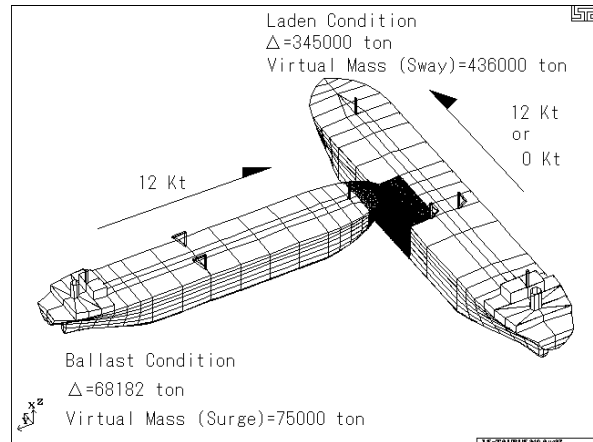

Fig.3.3-1 Collision scenario (Suezmax tanker)

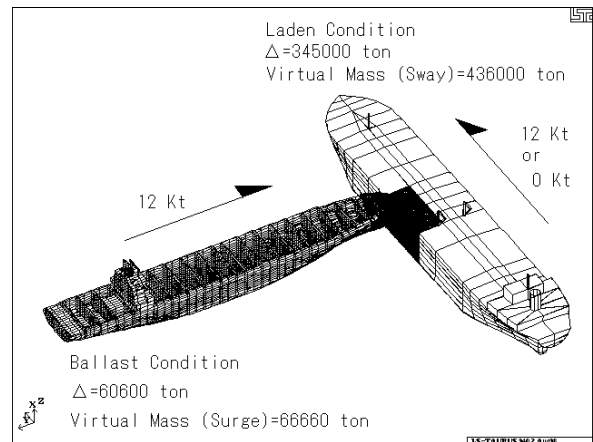

Fig.3.3-2 Collision scenario (Container ship)

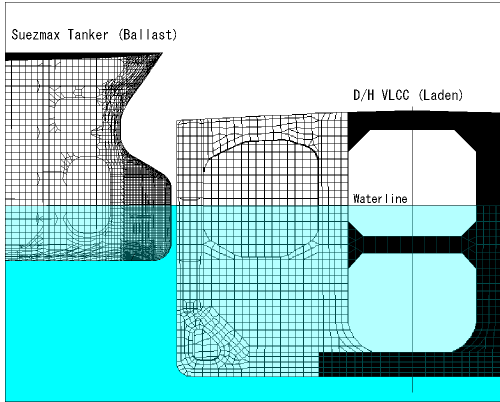

Fig.3.3-3 Contact point (Suezmax tanker)

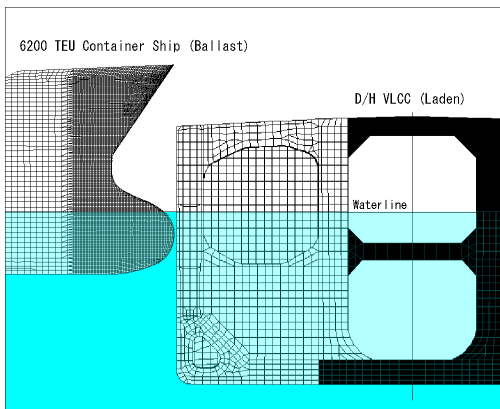

Fig.3.3-4 Contact point (Container ship)

3.4 Results

Figures 3.4-1 through 3.4-3 show the damage still in progress to the side of a D/H VLCC and bow of a Suezmax tanker having sharp-formed bulbous bow stiffened with standard side longitudinals. The rupture of side shell and inner hull is expected to occur about 0.33 and 0.95 seconds after the initial contact of penetrating bow respectively. The extent of severe side damage is limited. The degree of the bow crushing is slightly increased compared with the results of the ASIS research project (Kitamura 1998). No bend can be observed.

Figures 3.4-4 through 3.4-6 show the nearly total damage to the side of a D/H VLCC and bow of a Suezmax tanker having blunt-formed bulbous bow stiffened with standard side longitudinals. The rupture of side shell and inner hull is expected to occur about 0.45 and 2.45 seconds after the initial contact of penetrating bow respectively. The extent of severe side damage is expanded. The bow is crushed remarkably and bent aside to the advance direction of struck ship, i.e., a D/H VLCC.

Figures 3.4-7 through 3.4-9 show the nearly total

damage to the side of a D/H VLCC and bow of a Suezmax tanker having blunt-formed bow stiffened with vertical ring frames. The rupture of side shell and inner hull is expected to occur about 1.25 and 2.75 seconds respectively after the initial contact of penetrating bow, those are more or less delayed compared with the bow stiffened with standard side longitudinals. The extent of severe side damage is expanded further. The bow is crushed remarkably and bent aside as well. Because neither primary transverses nor side longitudinals are arranged, bow crushes without steps shown in figure 3.4-6.

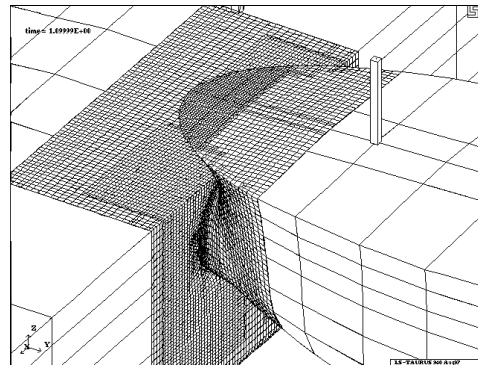

Fig.3.4-1 Damage (Suezmax tanker : Standard-sharp)

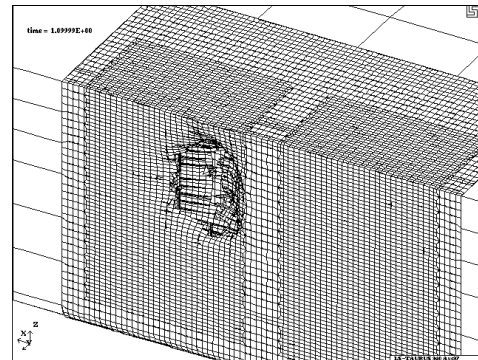

Fig.3.4-2 Side damage (Suezmax tanker : Standard-sharp)

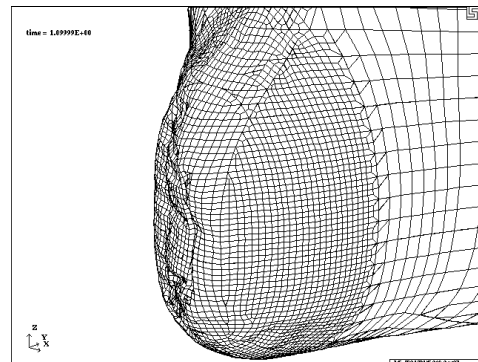

Fig.3.4-3 Bow damage (Suezmax tanker : Standard-sharp)

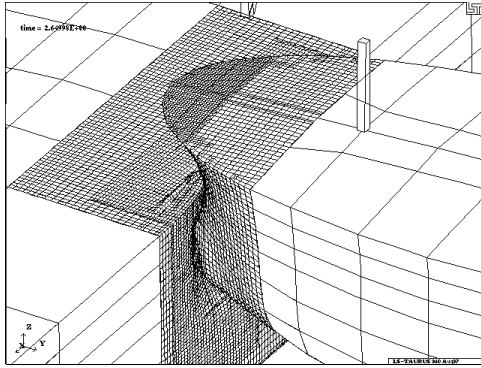

Fig.3.4-4 Damage (Suezmax tanker : Standard-blunt)

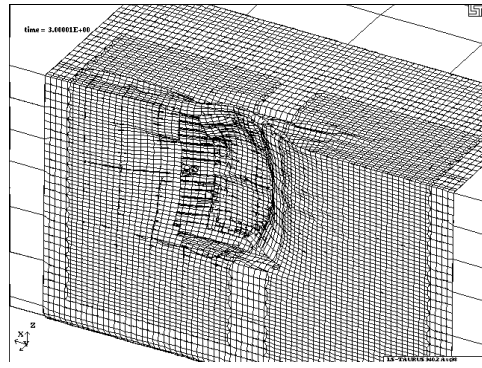

Fig.3.4-8 Side damage (Suezmax tanker : Buffer-blunt)

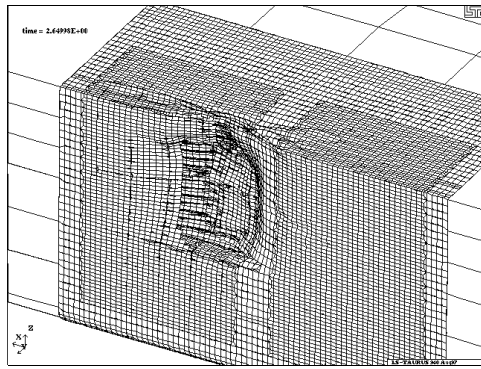

Fig.3.4-5 Side damage (Suezmax tanker : Standard-blunt)

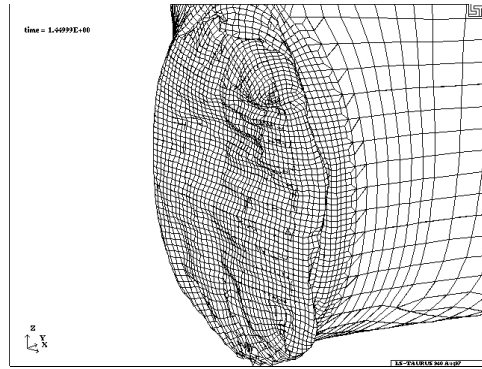

Fig.3.4-9 Bow damage (Suezmax tanker : Buffer-blunt)

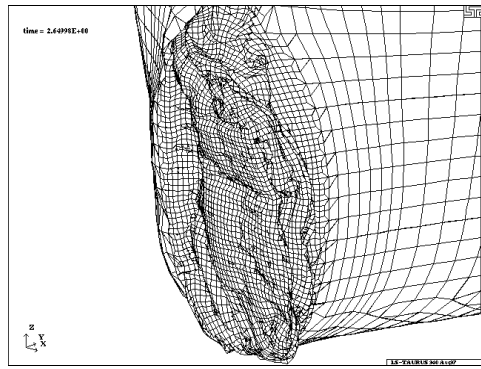

Fig.3.4-6 Bow damage (Suezmax tanker : Standard-blunt)

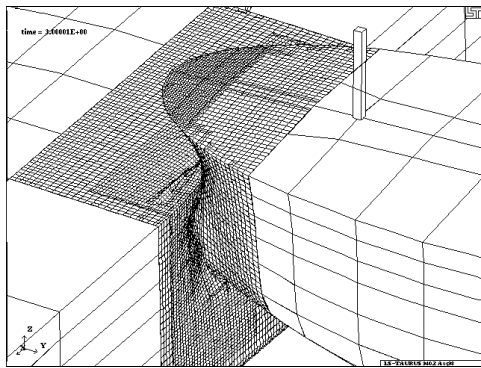

Fig.3.4-7 Damage (Suezmax tanker : Buffer-blunt)

The damage still in progress to the side of a D/H VLCC and bow of a container ship having sharp-formed bulbous bow stiffened with standard side longitudinals are shown in figures 3.4-10 through 3.4-12. Side shell and inner hull are expected to rupture rapidly about 0.20 and 0.90 seconds after the initial contact of penetrating bow respectively. The extent of severe side damage is quite limited. The degree of the bow crushing is negligible. Bulbous bow is slightly bent aside to the advance direction of the struck ship at the station aft of the forward perpendicular.

The total damage to the side of a D/H VLCC and bow of a container ship having sharp-formed bulbous bow stiffened with vertical ring frames is shown in figures 3.4-13 through 3.4-15. Neither Side shell nor inner hull is expected to rupture. Namely, no oil spill or seawater ingress can be anticipated. The extent of side damage is expanded due to the increased contact area caused by the considerable bend of bulbous bow as shown in figures 3.4-14 and 3.4-15. The bulbous bow is also crushed in its width (thickness) direction. Tearing is observed at bow flare part because the gunwale of a D/H VLCC penetrates into the bow as can be seen in figures 3.4-13 and 3.4-15.

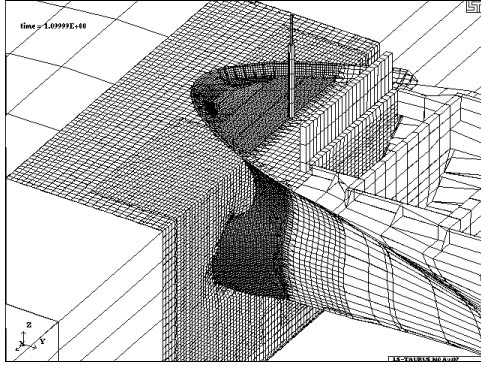

Fig.3.4-10 Damage (Container ship : Standard-sharp)

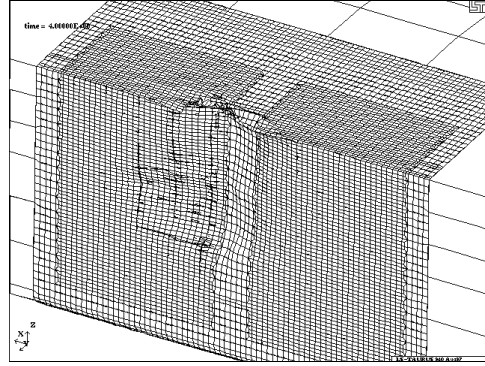

Fig.3.4-14 Side damage (Container ship : Buffer-sharp)

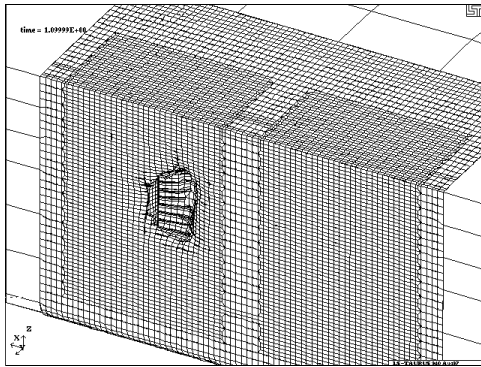

Fig.3.4-11 Side damage (Container ship : Standard-sharp)

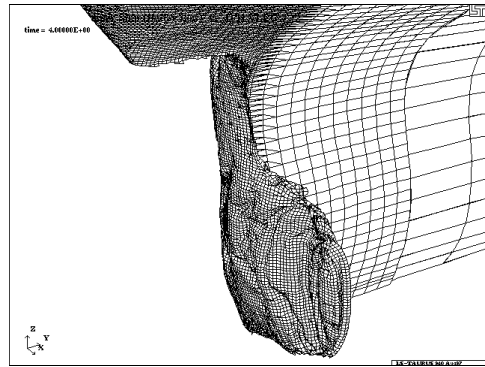

Fig.3.4-15 Bow damage (Container ship : Buffer-sharp)

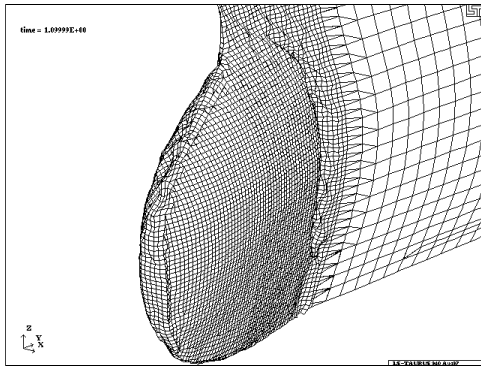

Fig.3.4-12 Bow damage (Container ship : Standard-sharp)

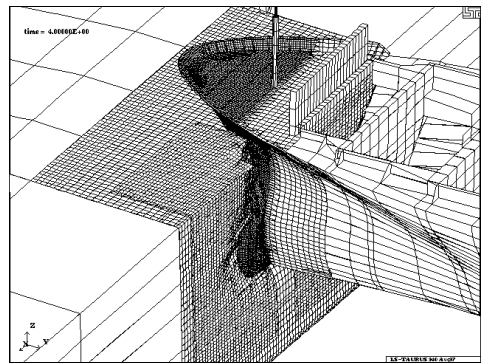

Fig.3.4-13 Damage (Container ship : Buffer-sharp)

Figures 3.4-16 through 3.4-18 show the results of a comparative study under the scenario that a Suezmax tanker collides with a D/H VLCC being at stand still without advance speed. However, a struck VLCC is left floating and free to move responding to the contact force. In this collision simulation, a Suezmax tanker is provided with blunt-formed bulbous bow stiffened with standard side longitudinals. Compared with figure 3.4-6, bulbous bow is crushed in a simple mode and no bend is observed. Naturally enough, the extent of severe side damage is reduced in the advance direction of a D/H VLCC. The rupture of side shell is expected to occur about 0.60 seconds, whereas inner hull is not ruptured.

The results of another comparative study under the scenario that a container ship collides with a D/H VLCC being at stand still without advance speed are shown in figures 3.4-19 through 3.4-21. A container ship is provided with sharp-formed bulbous bow stiffened with standard side longitudinals. Side shell and inner hull are expected to rupture rapidly about 0.25 and 0.80 seconds after the initial contact of penetrating bow respectively. The side structure is penetrated very sharply. The degrees of the bow crushing and bend are negligibly small.

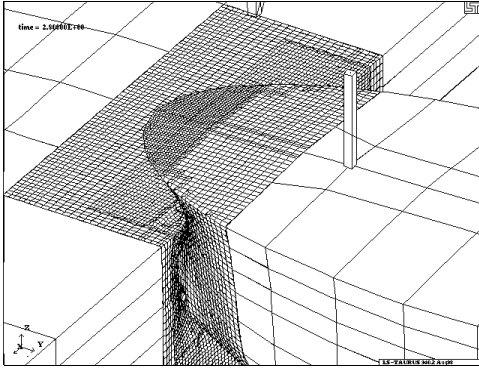

Fig.3.4-16 Damage (D/H VLCC at standstill)

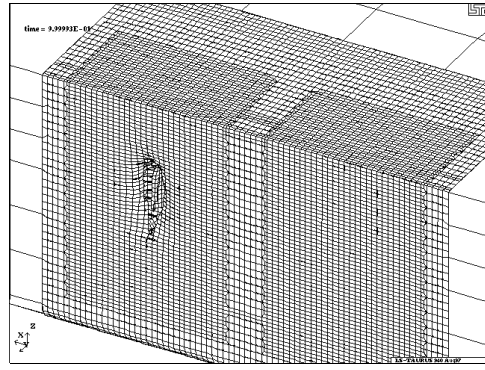

Fig.3.4-20 Side damage (D/H VLCC at standstill)

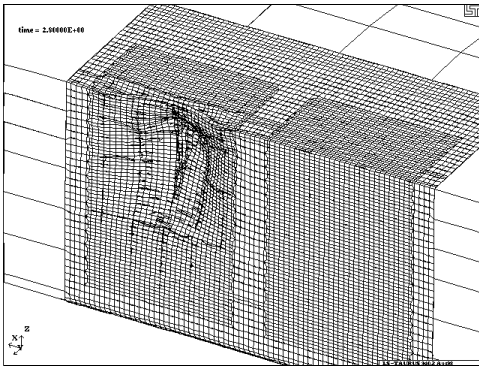

Fig.3.4-17 Side damage (D/H VLCC at standstill)

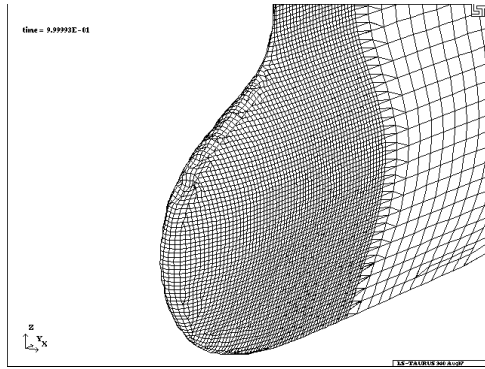

Fig.3.4-21 Bow damage (D/H VLCC at standstill)

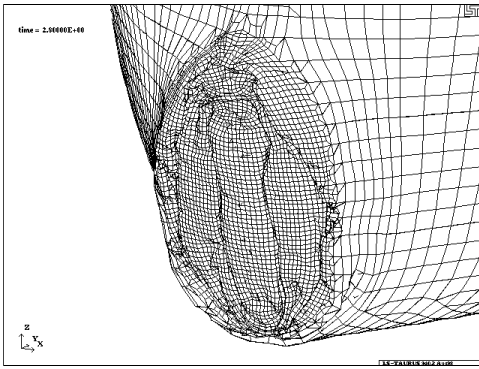

Fig.3.4-18 Bow damage (D/H VLCC at standstill)

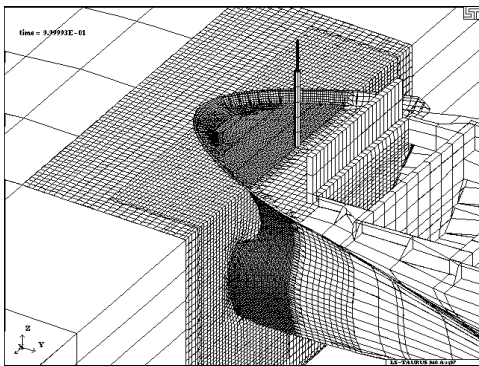

Fig.3.4-19 Damage (D/H VLCC at standstill)

Figures 3.4-21 and 3.4-22 show the time histories of the contact forces and energy absorption under the scenario that a Suezmax tanker collides with a D/H VLCC. As can be seen, differences are not remarkable in contact force, rupture initiation time and energy absorption when a Suezmax tanker is provided with blunt-formed bulbous bow, regardless of its internal stiffening system. The first peak of the contact force in the case of vertical ring framing system is reduced because of the accelerated crushing of the bow. On the contrary, the contact force becomes larger in the later stage as a result of the increased contact area. The dissipated kinetic energy of a Suezmax tanker and required amount of the energy to be absorbed by the structural damage can be approximately calculated based on the conservation law of momentum and energy. Judging from those results, it can be said that nearly 100 % of the required energy is absorbed when a Suezmax tanker is provided with blunt-formed bulbous bow stiffened with vertical ring frames. On the other hand, only about 25 % of the required energy is absorbed when a Suezmax tanker is provided with sharp-formed bulbous bow stiffened with side longitudinals until the inner hull (cargo tank boundary) is ruptured.

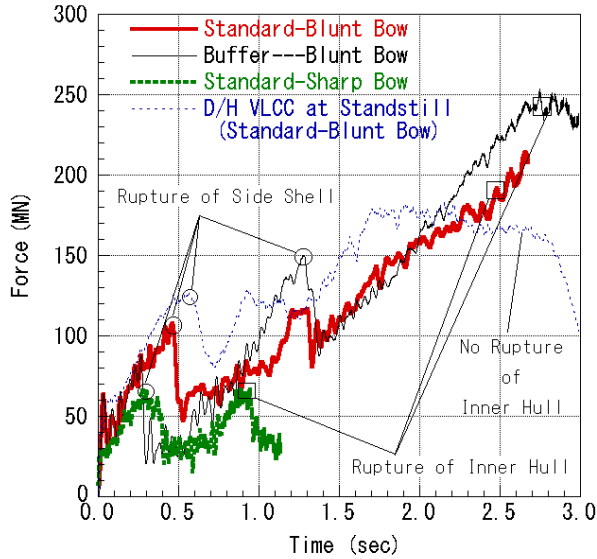

Fig.3.4-21 Contact force (Suezmax tanker)

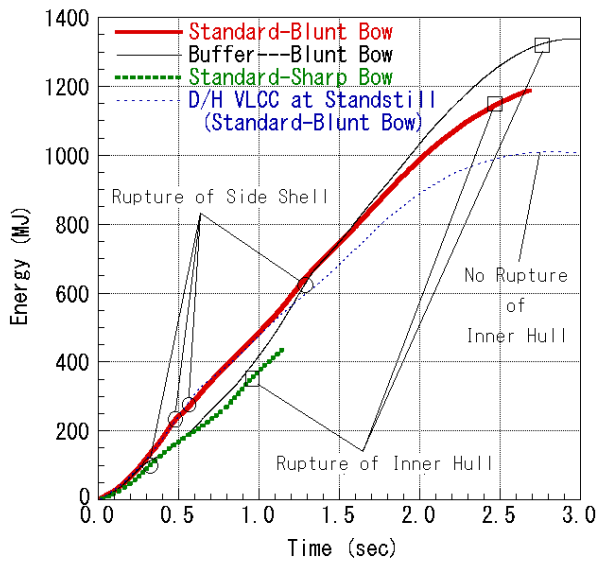

Fig.3.4-22 Absorbed Energy (Suezmax tanker)

Figures 3.4-23 and 3.4-24 show the time histories of the contact forces and energy absorption under the scenario that a container ship collides with a D/H VLCC. The differences are remarkable from every aspect. The point is whether considerable bend of bulbous bow does occur or not, which is attributed to its bending capacity or internal stiffening system. The first peak of the contact force in the case of vertical ring framing system is not reduced, whereas the contact force becomes far larger in the later stage similar to the scenario that a D/H VLCC is collided with a Suezmax tanker. It can be said that 100 %

of the required energy is absorbed when a container ship is provided with bulbous bow stiffened with vertical ring frames even though its form is sharp. On the other hand, only about 20 % of the required energy is absorbed when a container ship is provided with sharp-formed bulbous bow stiffened with side longitudinals until the inner hull (cargo tank boundary) is ruptured.

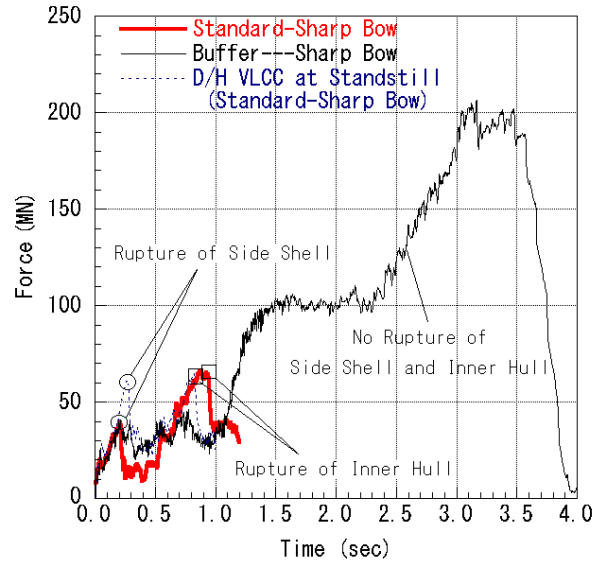

Fig.3.4-23 Contact force (Container ship)

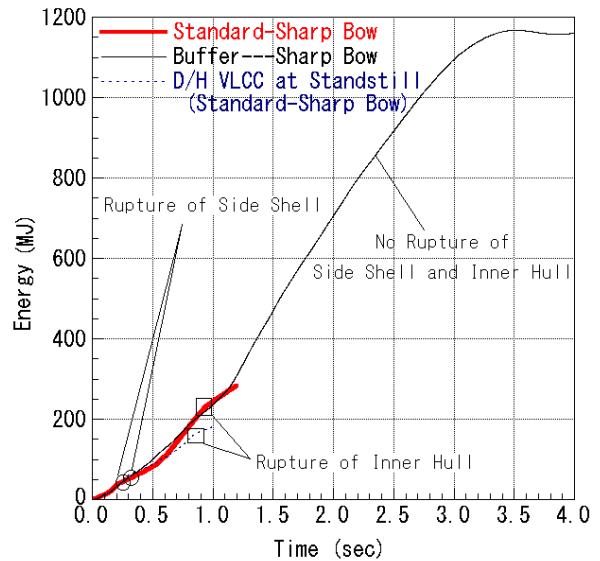

Fig.3.4-24 Absorbed Energy (Container ship)

In general, the rupture of side shell occurs slightly earlier when struck ship (a D/H VLCC) has advance speed. This is due to the additional tensile stress working in the

forward area of struck ship, which is mainly caused by the friction and direct contact due to the bow penetration. Forward and aftward areas of side shell are, of course, subject to the stretching from the beginning of the bow penetration regardless of the advance speed. As a result of early rupture of side shell, the first peak of the contact force is reduced, while the contact force recovers in the later stage with the expansion of the contact area more or less caused by the bend of bulbous bow. The recovery of the contact force is partly owing to the fact that the penetrating bow is sliding and contacting with intact side structure with the advance of struck ship.

It is to be noted that the total energy absorbed by the structural damage is larger when the struck ship (a D/H VLCC) has advance speed although the contact force in the direction of the bow penetration is generally small. The reason is that both colliding bow and struck side structure incur additional damage due to the advance kinetic energy of struck ship.

The collision simulations showed that the effect of the struck ship's advance speed could be considerable when the bulbous bow of a colliding container ship is stiffened with vertical ring frames (Buffer bow). Because the assumed friction coefficient of 0.3 might lead to the overestimation of the bending moment working on bulbous bow, a comparative simulation was carried out with friction coefficient of 0.1 for reference. According to the results, no significant difference in damage mode or contact force is found as shown in figure 3.4-25.

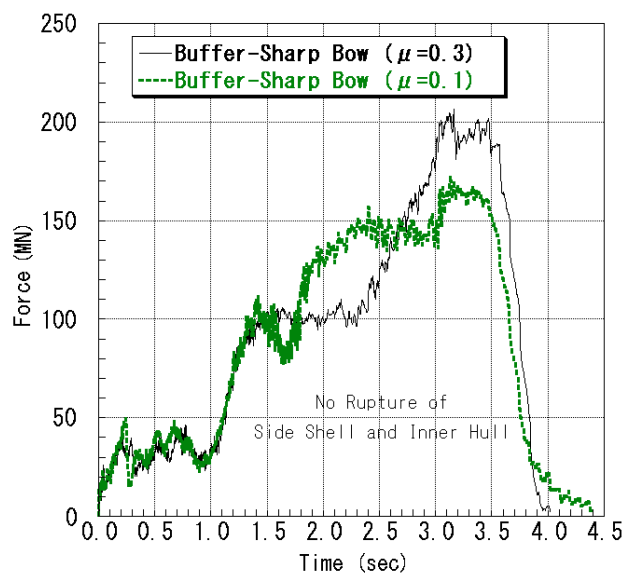

Fig.3.4-25 Contact force ($\mu = 0.3, 0.1$)

4. DISCUSSION

The results of this series of collision simulations suggests that the most dominant point is the form of bulbous bow, which governs both compressive and bending capacities of bulbous bow as well as the area of contact with the struck ship. A D/H VLCC struck by a Suezmax tanker may possibly be saved from an oil spill if the Suezmax tanker is provided with a blunt-formed bulbous bow. If the colliding bulbous bow's form is sharp, an oil spill is almost unavoidable.

The second dominant point is the stiffening system of the bulbous bow. Although the contact area is expanded with the accelerated crushing of bulbous bow stiffened with vertical ring frames, the increase in total absorbed energy until the rupture of inner hull (cargo tank boundary) may be limited because the energy absorbed by the crushing of the buffer bow itself is reduced. However, vertical ring framing effectively delays the rupture of the side shell, which is the cargo tank boundary of a single hull tanker or other kinds of single hull ships. When the form of bulbous bow is rather sharp like that of a container ship, the effect of the buffer stiffening design can be considerable because of the reduced bending capacity. This effect may be enhanced if the collision angle is other than a right angle of 90 degrees.

Roughly speaking, the effects of the early rupture of side shell, increased bend of bulbous bow, increased contact area and additional damage caused by the kinetic energy of the struck ship cancel out. Therefore from practical point of view, the effect of the advance of struck ship may be omitted provided that the bending capacity of bulbous bow is excessively large.

Because struck ship is given the advance speed and oiltight and swash bulkheads surpass the ordinary transverses in supporting rigidity, the initial collision point was located at mid-length between transverse oiltight and swash bulkheads. Except for the collision simulations with blunt-formed Suezmax tanker, the extent of elasto-plastic finite element modeling is considered acceptable for the severely damaged area on side structure is limited. When a Suezmax tanker having blunt-formed bulbous bow collides with a D/H VLCC, the expansion of severely damaged area is remarkable in both longitudinal and vertical directions. Therefore the adopted longitudinal extent of elasto-plastic finite elements might result in overestimation of the contact force for the degree

of lateral deformation of the side structure.

The additional compressive stress induced by the hull girder horizontal bending response can play a significant role depending on the combination of colliding (large) ship and struck (small, specially strengthened) ship (Kitamura & Endo 2000). Within the present collision simulations, the maximal level of the contact force is about 250 MN. As shown in figure 4-1, the estimated maximal hull girder horizontal bending stress at compression side is approximately estimated to be less than 100 N/mm², even though two-thirds of the side structures and half of inner hull structures are deducted from the section modulus calculation. Therefore it can be said that the coupling effect of the hull girder global bending response may not be significant as far as the present collision simulations are concerned.

As for the assumed friction coefficient, no serious difference in damage mode or contact force is found when the coefficient is ranging from 0.1 to 0.3.

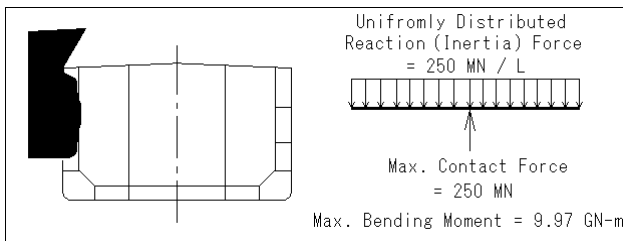

Fig.4-1 Hull girder horizontal bending response

The amount of energy to be absorbed by the damage to the structures can roughly be estimated based on the simple assumption that both colliding and struck ship are subject to the conservation law of momentum and energy. The factor of collision point along the length of struck ship can also be taken into account easily by the conversion of yaw motion to equivalent sway motion. If the collision point is away from the center of gravity (nearly midship) of struck ship as shown in figure 4-2, yaw motion occurs in addition to sway motion, i.e., virtual mass of struck ship “Ms” for sway motion appears to be lightened. Figure 4-3 shows the approximated values of energy to be absorbed by the structural damages to both colliding and struck ships. The assumed collision angle is 90 degrees and each amount of the energy is already deducted by 10 % considering the effect of friction work. As can be seen, the amount of the energy to be absorbed by the structural damage is not proportional to the initial kinetic

energy of potential colliding ships. The effect of the collision point is considerable when a colliding ship is large and a struck ship is relatively small. On the contrary, the effect is not notable when a colliding ship is small and a struck ship is large. The present investigations showed the following.

- 1) Buffer bow design, i.e., blunt-formed bulbous bow stiffened with vertical ring frames may effectively reduce the risk of oil spill and/or seawater ingress in various case of collision between large ships.
- 2) When a colliding ship has sharp-formed bulbous bow stiffened with side longitudinals, it is hard to avoid oil spill even in the case of a D/H VLCC collided with a handy class ship navigating at moderate speed.
- 3) There may be almost no practical way to save oil spill by the structural approach when a colliding ship is too large such as a VLCC and is navigating at high speed.

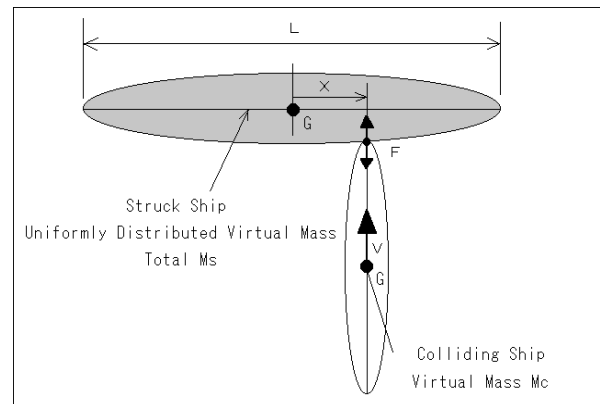

Fig.4-2 Approximation model of collision position

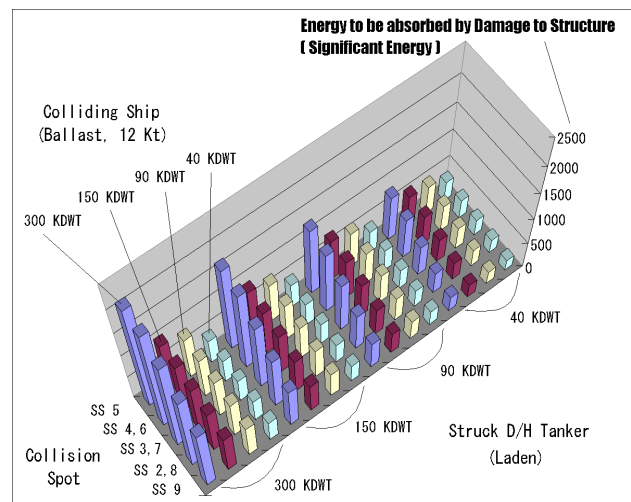

Fig.4-3 Energy to be absorbed by structural damage

The studies of RR76 panel are still in progress, however, the interim guideline for the buffer bow design at this stage can be proposed as follows.

- 1) Lower crushing pressure of bulbous bow is preferable to avoid the early and easy rupture of the side structure.
- 2) Larger energy absorption capability of bulbous bow, i.e., the integral of crushing force multiplied by the length, is preferable as far as the crushing strength does not exceed that of the side structure to increase total absorbed energy.

These may seem to be inconsistent, however, the larger contact area, longer potential crushing length and lower critical buckling strength of bulbous bow are the practical way to manage the above two issues. As shown explicitly by the present simulations or suggested implicitly by the previous studies (e.g., Lehmann & Yu 1995), the adoption of blunt form and vertical stiffening system to bulbous bow is easy solution to the larger contact area and reduced buckling strength respectively.

Otherwise the width (thickness) of the bulbous bow is better to be limited, at least in way of its root, to reduce the bending capacity. When the lateral force starts to cause the bend of bulbous bow triggered by the local buckling at compression side, additional bending moment caused by the axial contact force can accelerate the bend. The previous collision accident shown in figure 1-2 demonstrated the considerable bend of bulbous bow and crushing of the bow projected extensively above waterline.

Crushing pressure and strength can be controlled to a certain degree by the yield point of material because in general, the plate thickness is designed in proportion to the square root of the yield point (against lateral load) whereas the in-plane critical buckling stress of thicker plates is nearly proportional to the yield point.

As stated above, hull designers have free hand to a certain extent to develop the buffer bow design even in the case that the bow form should be strictly unchangeable due to the hydrodynamic viewpoint.

5. CONCLUSION

Generally speaking, the scantlings of bulbous bow are often designed beyond the requirements. For example, the thickness of side plate is usually increased to the same level as the adjacent bottom shell exposed to the slamming

impact pressure. Like the front design of an automobile, now the adoption of buffer bow design to ships is open to the discussion for the improved safety of all ships and environmental protection. Although the buffer bow concept cannot reduce the risks of oil spill drastically, there is no doubt about its effectiveness without requiring breakthrough technology nor additional cost is required.

REFERENCES

- Kitamura, O. (1997). Comparative Study on Collision Resistance of Side Structure, *Marine Technology*, Vol.34, No.4, pp.293-308
- Kitamura, O., Kuroiwa, T., Kawamoto, Y. and Kaneko, E. (1998). A study on the improved tanker structure against collision and grounding damage, *Proceedings of the 7th International Symposium on Practical Design of Ships and Mobile Units*, pp.173-179
- Kitamura, O. and Endo, H. (2000), *Collision Simulations of an Exclusive Ship of Spent Nuclear Fuels*, *Proceedings of the International Workshop on Utilization of Nuclear Power in Oceans*
- Kuroiwa, T., Kawamoto, Y., Kusuba, S. And Stillman, D. (1995). Numerical Simulation of Collision and Grounding of Ships, *Proceedings of the International Conference on Technologies for Marine Environment Preservation*, Vol.1, pp.66-70
- Lehmann, E. and Yu, X. (1995). Progressive Folding of Bulbous Bows, *Jahrbuch der Schiffbautechnischen Gesellschaft*, V101, 89, pp.88-97
- Paik, J.K, Chung, J.Y., Choe, I.H., Thayamballi, A.K., Pedersen, P.T. and Wang, G. (1999). On Rational Design of Double Hull Tanker Structures against Collision, *Preprints of SNAME annual meeting*, No.14
- Suzuki, K., Ohtsubo, H. and Sajit, K.S. (1999). Evaluation of Absorbed Energy in Collision of Ships ~ The Effectiveness of Minorsky's Formula in Anti-Collision Structure, *Journal of the Society of Naval Architects of Japan*, Vol. 186, pp.311-317
- Vredendeldt, A.W. and Wevers, L.J. (1992). Full Scale Ship Collision Tests, *Proceedings of Conference on Prediction Methodology of Tanker Structural Failure by ASIS*, pp.1-27
- Woisin, G. (1976). Die Kollisionsversuche der GKSS, *Jahrbuch der Schiffbautechnischen Gesellschaft*, Vol. 70, pp.465-491