

SSC-225

**STRUCTURAL ANALYSIS OF
LONGITUDINALLY FRAMED SHIPS**

**This document has been approved
for public release and sale; its
distribution is unlimited.**

SHIP STRUCTURE COMMITTEE

1972

SHIP STRUCTURE COMMITTEE

AN INTERAGENCY ADVISORY
COMMITTEE DEDICATED TO IMPROVING
THE STRUCTURE OF SHIPS

MEMBER AGENCIES:

UNITED STATES COAST GUARD
NAVAL SHIP SYSTEMS COMMAND
MILITARY SEALIFT COMMAND
MARITIME ADMINISTRATION
AMERICAN BUREAU OF SHIPPING

ADDRESS CORRESPONDENCE TO:

SECRETARY
SHIP STRUCTURE COMMITTEE
U.S. COAST GUARD HEADQUARTERS
WASHINGTON, D.C. 20591

SR-196
1972

Dear Sir:

One of the most important goals of the Ship Structure Committee is the improvement of methods for design and analysis of ship hull structures. In recent years, many analysis methods utilizing high speed electronic computers have been developed and although these methods allow detailed structural analyses which would have been impossible without them, they often require very large computers and involve considerable time and expense.

The project reported herein was undertaken in an attempt to develop a less expensive method of analysis, and the method has been verified by comparison with full scale experimental data. The Ship Structure Committee gratefully acknowledges the generosity of Chevron Shipping Company in supplying these data.

This report, the first in a sequence of four Ship Structure Committee reports on this project, contains a description of the development of the analysis method and the resulting computer program and the verification of the results obtained. Details of the computer program are presented in separate reports:

- SSC-226 - Tanker Longitudinal Strength Analysis--
User's Manual and Computer Program
- SSC-227 - Tanker Transverse Strength Analysis--User's
Manual
- SSC-228 - Tanker Transverse Strength Analysis--Pro-
grammer's Manual

Comments on this report or the associated project would be welcomed.

Sincerely,



W. F. REA, III

Rear Admiral, U. S. Coast Guard
Chairman, Ship Structure Committee

SSC-225

Final Report

on

Project SR-196, "Computer Design of
Longitudinally Framed Ships"

to the

Ship Structure Committee

STRUCTURAL ANALYSIS OF
LONGITUDINALLY FRAMED SHIPS

by

R. Nielson, P. Y. Chang, and L. C. Deschamps
COM/CODE Corporation

under

Department of the Navy
Naval Ship Engineering Center
Contract No. N00024-70-C-5219

*This document has been approved for public release and
sale; its distribution is unlimited.*

U. S. Coast Guard Headquarters
Washington, D. C.
1972

ABSTRACT

The technique of finite elements has brought about a new era to the field of structural analysis of ship structures. The application of this technique, however, is limited by the cost and capacity of the computer. Straight forward applications of the finite element method to the whole or to a major portion of the ship have so far been inaccurate and too expensive for design purposes.

The method presented combines the advantages of the finite element technique and the uncoupling by coordinate transformation. A fine mesh may now be used to produce more accurate boundary conditions. The uncoupling transformations also reduce the computer time to about one-tenth of that by other methods. The critical assumptions and the basic theories have been verified with experimental test results from the tanker "JOHN A. MCCONE."

This report discusses three computer programs; one for the longitudinal strength analysis, one for transverse strength analysis, and one for the local stability check of the structure. The programs themselves appear in subsequent reports.

CONTENTS

	Page
INTRODUCTION	1
LONGITUDINAL STRENGTH.	6
TRANSVERSE STRENGTH.	10
CORRELATION OF THEORETICAL STRESSES WITH STRAIN GAUGE EXPERIMENTS.	20
REFERENCES	26

APPENDICES

A. LONGITUDINAL STRENGTH, MATHEMATICAL DEVELOPMENT	28
B. TRANSVERSE STRENGTH, MATHEMATICAL DEVELOPMENT	31
C. STIFFNESS OF LONGITUDINALS.	38
D. INFLUENCE COEFFICIENTS AND DEFLECTIONS OF PRIME TRANSVERSE MEMBERS.	41
E. EFFECT OF LONGITUDINALS NOT COINCIDENT WITH NODAL POINT . .	43
F. SIMILARITY OF TRANSVERSES	46
G. APPLICATIONS OF PROGRAM TO ORE CARRIERS AND CONTAINER SHIPS	50
H. ANALYSIS OF PARTS OF THE HULL	54
I. STABILITY ANALYSIS.	58

SHIP STRUCTURE COMMITTEE

The SHIP STRUCTURE COMMITTEE is constituted to prosecute a research program to improve the hull structures of ships by an extension of knowledge pertaining to design, materials and methods of fabrication.

RADM W. F. Rea, III, USCG, Chairman
Chief, Office of Merchant Marine Safety
U. S. Coast Guard Headquarters

Capt. J. E. Rasmussen, USN
Head, Ship Systems Engineering
and Design Department
Naval Ship Engineering Center
Naval Ship Systems Command

Mr. E. S. Dillon
Chief
Office of Ship Construction
Maritime Administration

Mr. K. Morland, Vice President
American Bureau of Shipping

Capt. L. L. Jackson, USN
Maintenance and Repair Officer
Military Sealift Command

SHIP STRUCTURE SUBCOMMITTEE

The SHIP STRUCTURE SUBCOMMITTEE acts for the Ship Structure Committee on technical matters by providing technical coordination for the determination of goals and objectives of the program, and by evaluating and interpreting the results in terms of ship structural design, construction and operation.

NAVAL SHIP ENGINEERING CENTER

Mr. P. M. Palermo - Chairman
Mr. J. B. O'Brien - Contract Administrator
Mr. G. Sorkin - Member
Mr. H. S. Sayre - Alternate
Mr. I. Fioriti - Alternate

OFFICE OF NAVAL RESEARCH

Mr. J. M. Crowley - Member
Dr. W. G. Rauch - Alternate

NAVAL SHIP RESEARCH & DEVELOPMENT CENTER

Mr. A. B. Stavovy - Alternate

U. S. COAST GUARD

LCDR C. S. Loosmore, USCG - Secretary
CAPT C. R. Thompson, USCG - Member
CDR J. W. Kime, USCG - Alternate
CDR J. L. Coburn, USCG - Alternate

NATIONAL ACADEMY OF SCIENCES - Ship Research Committee

Mr. R. W. Rumke, Liaison
Prof. R. A. Yagle, Liaison

MARITIME ADMINISTRATION

Mr. F. Dashnaw - Member
Mr. A. Maillar - Member
Mr. R. Falls - Alternate
Mr. R. F. Coombs - Alternate

SOCIETY OF NAVAL ARCHITECTS & MARINE ENGINEERS

Mr. T. M. Buermann, Liaison

MILITARY SEALIFT COMMAND

Mr. R. R. Askren - Member
LTJG E. T. Powers, USNR - Member

BRITISH NAVY STAFF

Dr. V. Flint, Liaison
CDR P. H. H. Ablett, RCNC, Liaison

AMERICAN BUREAU OF SHIPPING

Mr. S. G. Stiansen - Member
Mr. F. J. Crum - Member

WELDING RESEARCH COUNCIL

Mr. K. H. Koopman, Liaison
Mr. C. Larson, Liaison

INTRODUCTION

Prelude

The ship hull is a complex structure subject to the multiple static and dynamic loadings imposed by its mass, its contents, and the time-dependent forces of the sea. A satisfactory procedure of structural design requires a complete knowledge of the loadings as well as a method of accurate structural analysis. While this ultimate goal may not be reached for some time, improvements have been made in both areas.^{1,2,3} The most notable developments in structural mechanics as applied to ships have been the techniques of finite elements^{4,5} and the theory of grillages.^{6,7,8,9} The complexity of a ship's hull suggests that the versatile finite element technique would be the ideal analysis tool if the computer time can be held down to within a reasonable limit for an acceptable degree of accuracy.¹⁰ In the light of this problem, then, this report presents a new approach to the analysis of longitudinally framed ships. Its theoretical foundation is based upon the following three observations:

1. Results from full-scale ship tests confirm that the ship hull of moderate size behaves closely as a simple beam with shear deflection. The trend of modern shipbuilding, however, has been toward increasingly larger ship hulls, and the future may require refinements to this elementary method of analysis to include the possible effects of expanded beam/length and beam/depth ratios.

2. Past structural failures of large tankers revealed principal areas of damage at the intersections of the prime longitudinal (longitudinal bulkheads, side shells, deep longitudinal girders) and transverse members (the oil-tight and swash bulkheads, and the deep transverse web frames).¹¹ The lines of buckling often showed the characteristic features of deformation under excessive shear loads and indicate that the shear loads at the intersections of these prime members must be recognized as important factors in the structural analyses of these ships.¹¹

3. The theoretical naval architect has long recognized the flow pattern of load transference among the structural members of the longitudinally framed ship as follows: Loads from the plate are transferred to the longitudinal frames, then to the prime transverse members (i.e., bulkheads and web frames) and finally to the prime longitudinal members. However, this flow pattern has never been considered in the calculation of the longitudinal strength of ships, and only very recently has it been considered in the transverse strength analysis.^{3,12} As the size of tankers increases, this flow pattern assumes greater importance.

A BRIEF REVIEW OF THE STATUS OF SHIP STRUCTURAL ANALYSIS

The conventional approach for a ship's structural analysis can be divided into three stages: First, the ship hull is treated as a thin-wall simple beam to determine the primary or longitudinal strength.

The validity of this modeling technique has been verified by Vasta's investigations¹³ for ships of 50,000 tons or smaller. But for the ship hull to behave as a thin-wall simple beam, the transverse members must be strong enough to maintain an essentially constant hull cross-section.

The second stage is the transverse strength analysis for which several approaches have been used. One is to treat the transverse member as an independent, reinforced two-dimensional space frame¹ or elastic body¹⁴ with the shells, longitudinal bulkheads and central girders modeled as concentrated springs, but with the effect of the smaller longitudinal members neglected. To regain more of the coupling effects, another method has been to treat the stiffened panels of bulkheads, decks, bottom and side shells as orthotropic plates, grillages or two or three-dimensional space frames with calculations confined to one hold only. More recently, the technique of finite elements has been applied whereby the entire hull or a portion thereof is modeled as a three-dimensional structure. The resulting solutions then provide the boundary conditions for a more detailed analysis of the transverse member under study.^{10,5,3,15}

Finally, the unstiffened plate panels are treated as isotropic plates to determine the tertiary stresses.

Although the conventional longitudinal strength analysis has proved to be adequate for ships of moderate size, evidence suggests that a more elaborate method is needed for very large ships. As a three-dimensional floating structure, the ship is subject to not only vertical bending, but also girth bending and compression, horizontal bending, and twisting. For ships with small beam/length and beam/depth ratios, the only important factors are the vertical bending and the girth compression. All other factors may be neglected, except for twisting in ships with large deck openings. For very large vessels, on the other hand, all of these factors may be significant. This report goes one step beyond existing methods to include the effects of deformation of the transverse and shear distribution between the prime longitudinal hull girders and transverse members. The effects of twisting and horizontal bending are left for future investigations.

For the transverse strength, the frame analysis is simple, but there is no unique way to determine the stiffness and span of each member. The method to determine the spring factors is still an art rather than a science, and different investigators can obtain very different results for the same structure even when using the same computer program. The determination of boundary conditions has been a subject of much discussion but remains unsettled. The best way to avoid difficulty is to take a larger portion of the structure into consideration.

The principle of super-position is valid only if the boundary conditions adopted in each stage of the calculations are exactly definable; this situation, however, is generally impossible since the boundary conditions of any region are functions of both the ship's geometry and the loads acting upon it.

THE APPLICATION OF THE TECHNIQUE OF FINITE ELEMENTS TO THE ANALYSIS OF SHIP STRUCTURES

The finite element method (FEM) has been used effectively for many years by the aerospace and civil engineers. In fact, it constitutes the only practical method for the analysis of complex structures and as applied to ship structures in recent years has produced good results.^{3,5,10,15}

Although the basic theory of FEM is well known to engineers, it is important to review the accuracy of this technique, which depends upon the following four factors:

1. The discretization of the real structure. The continuous structure must be idealized into discrete elements. The consequence of approximating a continuum of infinite degrees of freedom with a model of finite degrees of freedom is the discretization error which is often measured by how closely assumed displacement functions can represent the true displacements.

2. The types of elements. Many types of elements have been developed for different purposes. The type of element for which the assumed displacement functions satisfy all compatibility conditions at the boundaries of the element is called conforming. Since such functions are difficult to develop for some types of elements, functions which satisfy only portions of the compatibility conditions may have to be used. These elements are then non-conforming. The difference between the two types is that as the size of the element approaches zero, the sequence of approximate solutions converges to the exact solution for the conforming element but may converge to an incorrect value or even diverge for non-conforming elements. Although the conforming elements do not necessarily yield better results in a very coarse mesh, due to other approximations involved, they are preferable whenever possible for analysis in finer meshes.

3. The number of elements and the rounding error. For analyses using conforming elements, the discretization error may be reduced by using a finer mesh; i.e., increasing the number of elements. However, as the number of degrees of freedom increases, another kind of error begins to grow. The computer recognizes only a certain number of digits of any numerical value; and, consequently, round-off errors can accumulate and become very large at the end of a computation. Since this error increases with the number of degrees of freedom, a finer mesh may even produce a greater net error depending upon the methods of computation and the computer. This error may be reduced with an improved computational procedure and with double precision, but a limit will always exist where the increase in rounding error is larger than the decrease in the discretization error.

4. The accuracy of boundary conditions. To reduce rounding errors and the computer time expense, the common approach is to use a macro mesh for the whole structure; for a ship the macro mesh may consist of elements as large as a basketball court. The solutions from this macro mesh analysis are then used as boundary conditions for the analysis of a still smaller region using a micro mesh, and so on.

Unfortunately, the accuracy of the detail analysis can never be better than the accuracy of the boundary conditions. If the results from the macro mesh analysis are questionable, the solutions from the micro analysis are also suspect. The use of the macro mesh of non-conforming elements promises results that are, at best, very rough approximations.

PROPOSED MODIFICATIONS TO THE FINITE ELEMENT METHOD OF ANALYSIS

To reduce the discretization errors at boundary conditions, the method presented in this report employs a much finer mesh for the three-dimensional analysis. The problems of the round-off errors, the computer expense, and of the limited computer capacity are alleviated by the coordinate transformation technique introduced in Appendix B.

OUTLINE OF THE NEW APPROACH AND ITS BASIC ASSUMPTIONS

The following approach includes both a longitudinal and a transverse strength analysis.

A. Longitudinal strength analysis.

1. The longitudinal bulkheads with deck and bottom plate of the central tank and the side shells with deck and bottom plate of the wing tanks are defined as prime longitudinals. The prime longitudinals and the transverses behave as simple shear beams. Vasta¹³ has verified this assumption for the not-so-large ships, and no evidence indicates that this assumption is invalid for the large tankers.
2. The prime longitudinals are assumed to be simply supported at both ends. The simply supported end is the same as the free end if the shear force is zero. Since the external loads are self-balanced, the shear forces at the end should be small, and the sum of shear forces of these prime longitudinals is actually equal to zero.
3. The transverse members are assumed to be free at both ends.
4. The shear forces in the deck and bottom plating are small relative to the longitudinal stresses near the intersections of the longitudinal bulkheads. This assumption has been verified by experiment in a 90,000 ton tanker.¹⁴
5. The transverses are in turn supported by the prime longitudinals. This load transfer pattern indicates that the prime longitudinals are acted upon by the reactions of the transverses only. This is an improvement over the conventional method which implies that the external loads are acted upon the prime longitudinal directly.

6. The effect of local or secondary deformations of the transverses on the longitudinal stress is negligible. This is the basic assumption for the conventional longitudinal strength analysis. However, the primary deformations of the transverse member between the shells and longitudinal bulkheads are not neglected.

B. Transverse strength analysis.

1. All longitudinals are assumed to be similar, or of proportional stiffness. This implies that the moment of inertia changes by the same ratio along the length for all longitudinals. This is true for most ships.
2. All transverse members are assumed to be similar, or of proportional stiffness. This assumption is a necessary approximation. The error caused by this assumption is small in terms of the actual reactions acting upon the transverses.
3. The external loads are acting upon the plate and transmitted to the longitudinals supported by the transverses. Loads may be distributed and need not be converted to concentrated forces at element nodal points.
4. The external loads are arbitrary insofar as they are symmetric about the center plane of the ship. Unsymmetric loading systems can be treated as the sum of a symmetric system and an antisymmetric system. The present computer program is applicable to both loading systems.
5. The longitudinal beam elements are assumed to be simply supported at both ends of the ship. Since the external loads of the ship are self-balanced, this assumption is the same as the conventional free-free condition. They may be simply supported or fixed for partial analysis depending upon the loading conditions and the nature of the hull structure.
6. The effect of the torsional rigidity of the longitudinals is neglected for two reasons. This effect is negligible for all longitudinals with open cross section, and the in-plane twisting at the nodal points cannot be accommodated by the plane finite element theory.
7. The bending stiffnesses of the plate elements are neglected. Kendrick¹⁵ verified this stand by showing that bending stiffness has virtually no effect on in-plane stress.

C. The stability check

The stability check formulas as given in Appendix I are interpolated from established criteria in the literature^{16,17,18} for the simply supported plate. While this modeling assumption is not exact for the web plate of the transverse members, it does provide a good upper bound for design purposes.

LONGITUDINAL STRENGTH OF LARGE SHIPS

For many years, the longitudinal strength of ships has been calculated by the simple beam theory. Recently, attempts have been made to apply three dimensional finite element analyses to the whole ship structure.^{10, 19} In addition to providing the longitudinal strength, this analysis can also provide information about the vertical shear loads upon the longitudinal bulkheads and side shells and also boundary conditions for local analysis. Due to computer expense and the limit of the number of elements available, only coarse mesh analyses have been possible.

In recent years, an excellent computer program for tanker analysis has been developed by Kamel¹⁰ et al. The longitudinal stresses calculated by DAISY¹⁰ show only slight deviations from the linear stress distribution except at locations where the bending moment is small. This coarse mesh analysis, however, does involve some error on the idealization of both the loading and the structure where additional forces are required for balancing the model.¹⁰

An analysis similar to DAISY was performed on the ESSO NORWAY using the program SESAM-69.¹⁹ The results indicate fairly large discrepancies between the measured and calculated deflections. Results obtained from simple beam theory, on the other hand, have proved to correlate quite well with full-scale experiments, although these experiments were conducted on much smaller ships than the ESSO NORWAY.

Authorities generally agree that the longitudinal strength standards adopted by the societies using the simple beam theory are quite adequate even for super tankers. For these reasons, then, a coarse mesh finite element analysis for the longitudinal strength is really unnecessary.

A simple and accurate method to calculate the distribution of the shear load between the longitudinal bulkheads and the side shells, however, is needed. This can be done by treating the hull as a grillage consisting of four prime longitudinal members (the side shells and the longitudinal bulkheads) and the prime transverse members (transverse bulkheads and web frames). (See Fig. 2-1). The transverse members include portions of the deck and bottom as flanges. The shell members include portions of the connected deck and bottom plating as flanges. Similarly, portions of the bottom and deck are ascribed as flanges for the longitudinal bulkhead members. The member definitions should be such that the total moment of inertia of the hull is exactly equal to that derived in the conventional manner.

The prime longitudinals are assumed to be simply supported at both ends. The simply supported end condition is the same as that for the free end if the shear force is zero. Since the external loads are self-balanced, the shear forces at the ends should be small, and the sum of shear forces of these four longitudinal members should actually be zero. The transverse members are assumed to be free at both ends.

The shear forces in the deck and bottom plating are assumed small relative to the longitudinal stresses near the intersections of the longitudinal bulkheads. The external loads are assumed to be acting upon the plate and transmitted to the prime transverse members through the longitudinals.

For symmetrical loads this new approach is identical to the conventional simple beam theory if the prime transverse members can be treated as perfectly rigid. But this method is more useful because the shear loads on the prime members can be calculated accurately. In addition, the stress due to transverse bending can also be calculated.

The formulation of this method is given in detail in Appendix A.

A computer program has also been prepared. As illustrated in Appendix A, this method is only slightly more complicated than that of the conventional simple beam but still requires only a few seconds of the computer time for the calculations.

Table 2-1 provides a sample comparison of the longitudinal deck stresses derived from both the conventional simple beam method and from the new grillage approach which further determines the relative sharing of the load support by the side shells and the longitudinal bulkhead. The validation of the grillage method here actually gives evidence of the approximations made by the conventional method.

The distribution of vertical shear force between the longitudinal bulkheads and the side shell is plotted in percentage in Figure 2-2. It is pointed out here that Roberts³ has treated the cargo portion of the tanker as a grillage for the shear loads prior to this paper and has devised a formula for this purpose. The principle of his method is similar to that of the new approach, although some differences are notable. These discrepancies are due to the fact that the Roberts' formula excludes the effects of the position of the loading relative to the central plane and of the stiffnesses of the transverses. Results from a longitudinal analysis of the "JOHN A. MCCONE" indicate the importance of these two factors and hence do not conform with Roberts' simple formula.

Several computer programs such as STRESS and STRUDL can be adequately applied, but they are more difficult and expensive to use than what is introduced in this report. The proposed grillage analysis is tailored for the longitudinal strength calculations and includes deformations due to shear as well as bending of the deep primary members. The method is based on the technique of transfer matrices, and hence, the results should be the same as those obtained by a frame analysis except that the computer time should be significantly reduced.

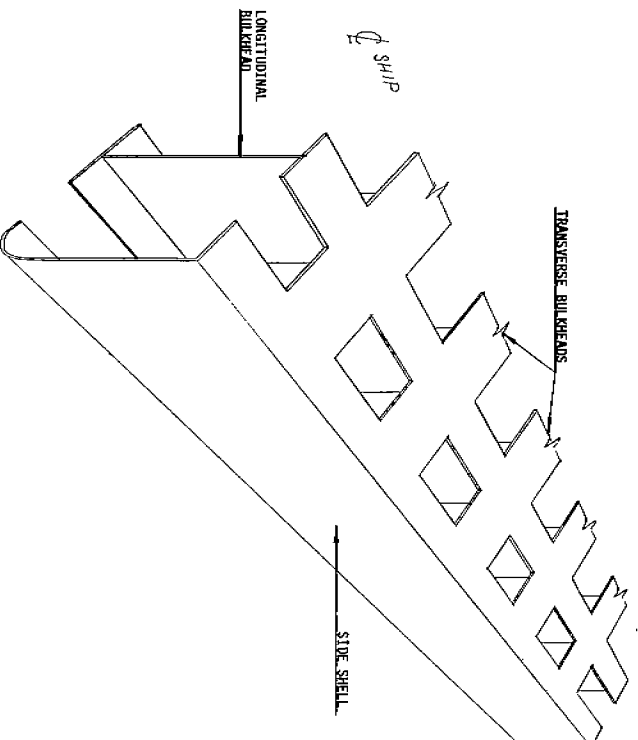

Fig. 2-1. Structural Model for the Longitudinal Strength Analysis of Ships

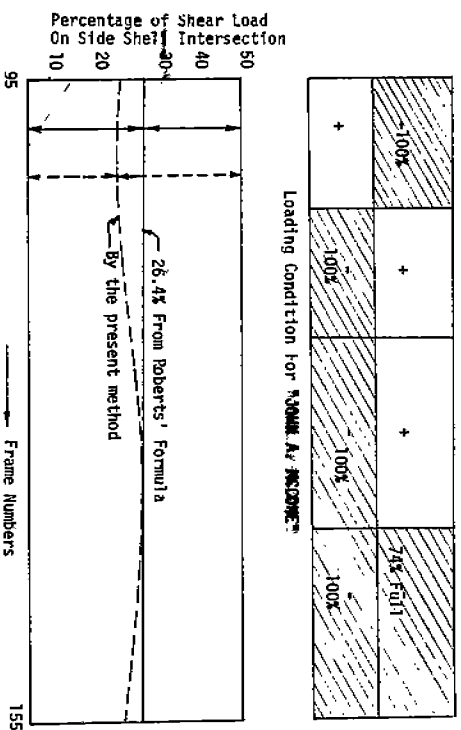

Fig. 2-2. Shear Load Distribution Between Side Shell and Longitudinal Bulkhead

Table 2-1. Relative Longitudinal Stress on Deck. kg/mm^2

Frame No.	By new Grillage Method		
	Conventional Method	Near Side Shell	Near Longitudinal Bulkhead
97	---	---	---
99	0.59	0.57	0.66
101	0.87	0.88	0.91
103	1.14	1.15	1.20
105	1.40	1.43	1.45
107	1.64	1.75	1.64
109	1.86	2.03	1.80
111	2.02	2.20	1.95
113	2.13	2.30	2.08
115	2.18	2.37	2.12
117	2.18	2.37	2.12
119	2.13	2.28	2.10
121	2.02	2.19	1.97
123	1.86	2.02	1.81
125	1.65	1.78	1.62
127	1.39	1.51	1.34
129	1.07	1.16	1.04
131	0.70	0.74	0.69
133	0.27	0.30	0.26
135	-0.20	-0.22	-0.19
137	-0.74	-0.85	-0.69
139	-1.23	-1.34	-1.20
141	-1.57	-1.70	-1.54
143	-1.83	-1.94	-1.71
145	-1.83	-1.98	-1.80
147	-1.75	-1.89	-1.73
149	-1.53	-1.66	-1.49
151	-1.17	-1.23	-1.17
153	-0.66	-0.68	-0.68

TRANSVERSE STRENGTH OF LARGE SHIPS

The conventional two or three-dimensional analyses of transverse strength often assumes a pre-deformed state of the structure, where the supporting forces upon the transverses of the hull have been either neglected or roughly approximated. Most analysts simply treat the effect of the ship's hull as several rigid or spring supports. The spring constants, however, are more artfully derived than precisely developed from the hull structure as a contiguous system. A three-dimensional finite element solution for these boundary conditions has also proved inaccurate since a coarse mesh must be used.

The method presented here is similar to the three-dimensional finite element techniques in use, but a much finer mesh is generated to improve accuracy, and the uncoupling via coordinate transformations simplifies the numerical computation and thus reduces the computer time. The ship's hull is modeled as a three-dimensional elastic body consisting of beam elements representing the longitudinals and plate and bar elements representing the transverses (Fig. 3-1). The nodal points at the boundaries and the transverses are located on the intersections with the longitudinals wherever possible. (The effect of longitudinals that do not coincide with any nodal point is accounted for by the method introduced in Appendix E.) The longitudinals are simply supported at both ends and the transverses are restrained from horizontal movement along the center line because of symmetry and are also supported by an artificial support at the bottom of the longitudinal bulkhead (Fig. 3-2).

The three-dimensional coupled structure of the transverse analysis requires as input the supporting shear forces generated within the hull girder by the external loading conditions. The external loading conditions, then, are used to compute the secondary deflections of the longitudinal members and the elastic deformations of transverses. Both the deflections of the prime longitudinals (equal to the rigid body motions of the transverses) and the supporting shear forces are available directly from the longitudinal strength analysis. (Fig. 3-3). The shear forces upon the transverses are actually the changes in longitudinal shear and may be applied directly to the transverse members as external loads. Many analyses simply neglect these forces in the transverse model and allow the resulting force loading imbalance to be corrected by the development of concentrated reaction forces at the transverse boundary supports, as illustrated in Figure 3-2.

The point support at the intersection of the bottom plate and the longitudinal bulkhead is not necessary when the hull is treated as a three-dimensional structure, but is necessary for the final two dimensional analysis when the supports of the longitudinals are replaced by boundary forces. If the reactions of the longitudinals upon the transverses are balanced exactly by the supporting forces (longitudinal shear drop) of the longitudinal bulkheads and side shells, then forces at the imaginary transverse boundary supports should be zero. But since the local deformations of the transverses are not considered in the longitudinal strength calculations, this ideal condition may not be completely satisfied. The resulting discrepancies, however, should be smaller than those developed with the conventional treatment of these support forces.

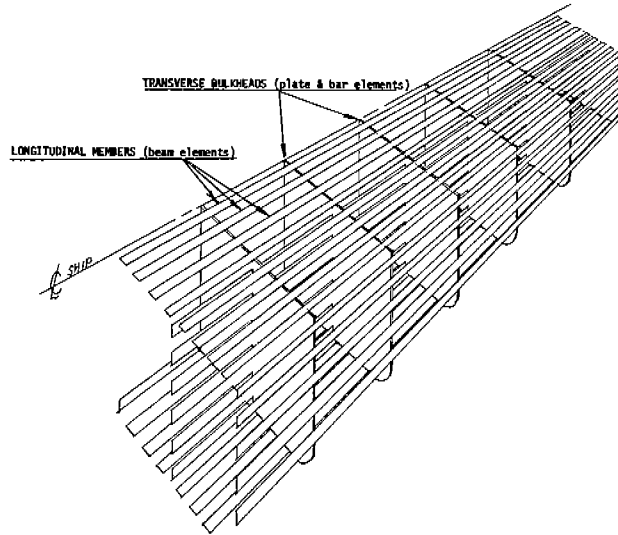

Fig. 3-1. Structural Model for the Transverse Strength Analysis of Ships

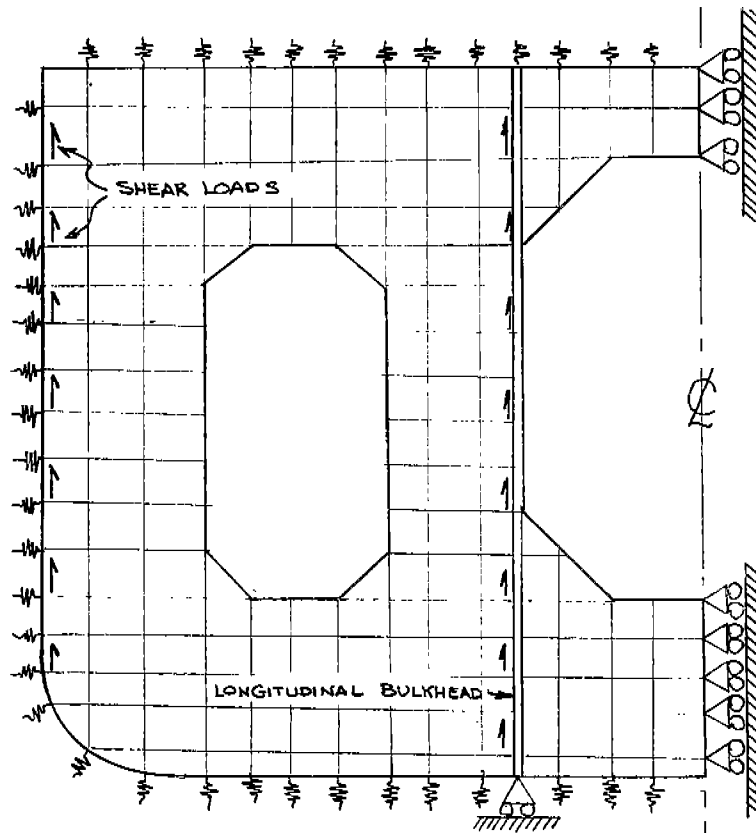

Fig. 3-2. Transverse Boundary Conditions for Symmetrical Loading

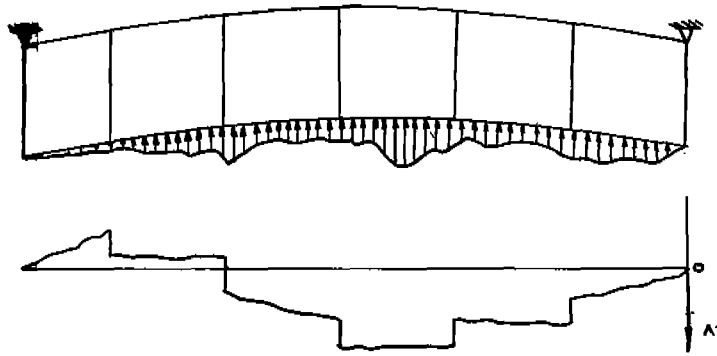

Fig. 3-3a. Primary Deflections and Supporting Forces (From Longitudinal Strength Analysis)

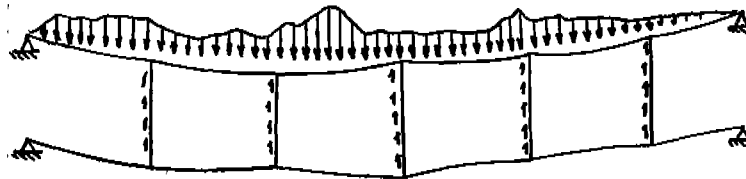

Fig. 3-3b. Primary Deflections Super-Imposed With Secondary Deflections (From Transverse Strength Analysis)

By the method presented in Appendix B, this three dimensional system is mathematically uncoupled into a set of equivalent two dimensional transverse members, each loaded with transformed forces and supported by transformed spring elements which represent the effects of the longitudinals. Since both these transformed forces and spring constants can be computed directly, the resulting quasi displacements of the transverse boundaries can be calculated. Upon re-coupling the system, these displacements provide the actual forces exerted by the longitudinals upon the transverses. With these reaction forces known, the stresses within the transverse members may be computed using a conventional two dimensional finite element analysis. See Figure 3-4.

The feasibility of the uncoupling technique depends upon the acceptance of certain assumptions which render the mathematics more tractable. First, the method assumes that all longitudinals are similar; this is a good approximation for most large ships, particularly within the mid-body section. Secondly, all transverse members (web frames, oil-tight and swash bulkheads) are treated as being of proportional stiffness. While this latter modeling technique may not appear very exact, a 100 per cent error in a given constant of proportionality will produce only a very small percentage error (perhaps 0.5 per cent maximum) in the force reactions at the transverse boundaries. In fact, two sets of calculations were made for the same structure under the same loading condition but with

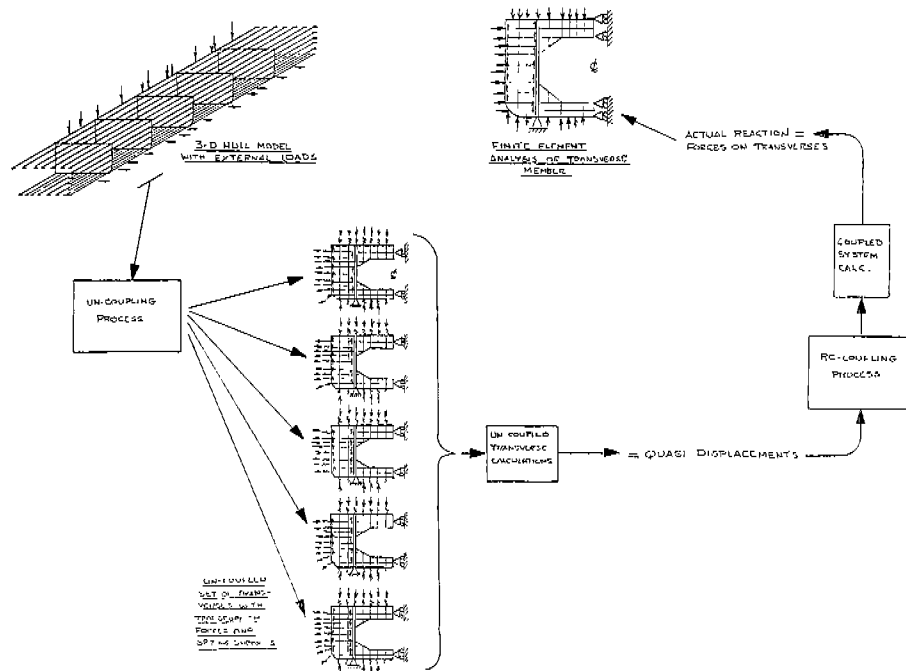

Fig. 3-4. Transverse Strength Analysis

the stiffness factor for the oil-tight bulkheads varied in magnitude. The boundary forces from these calculations are practically identical (See Table 3-1). The negligible effects of the transverse stiffnesses are due to the fact that the transverses are much stiffer than the longitudinals.

The uncoupling technique can be reduced to the conventional iteration process. However, the iteration is convergent only if the stiffness of the longitudinal is considerably smaller than that of the transverse.

A transverse analysis was performed on a simple box girder. (Fig. 3-5). This model includes 47 beam and 45 triangular plate elements and was analyzed both by the new method and by a standard three dimensional finite element computer program (Control Data Corporation's EASE).

Since this box girder is symmetrical about its central plane and about the swash bulkhead, it is necessary for the three dimensional analysis to include only a quarter of the structure for the EASE analysis. This quarter is shown in Figure 3-6, and modelled as illustrated in Figures 3-7 and 3-8. Since the present programs have not been set up for symmetry along the longitudinal, a full half of the structure was included in the parallel analysis.

The properties of this model are listed as follows:

Length	80'
Depth	60'
Width	60'
Longitudinal members No. 1, 11	$I_x = I_y = 0.22 \text{ ft.}^4$ $A = 0.22 \text{ ft.}^2$
Longitudinal members No. 4, 8	$I_x = I_y = 1.1 \text{ ft.}^4$ $A = 1.1 \text{ ft.}^2$
Longitudinal members No. 2,3,5,6,7, 9,10	$I_x = I_y = 0.11 \text{ ft.}^4$ $A = 0.11 \text{ ft.}^2$

Where A = cross section area

I_x, I_y moment of inertia about x,y - axis.

(The values of cross-sectional area and moment of inertia include the attached plate.)

Thickness of the deck, bottom, and side plate	0.02 ft.
Thickness of the web and bulkhead	0.04 ft.
Cross-sectional area of the flange of web frames	0.4 ft.^2

For this simple example, it is not necessary to use the longitudinal strength program. The bending moment can be calculated by the simple beam method. The shear force acting upon the transverses are just the sum of the external loads at the bottom, 5,000 kips. This sum is divided evenly to the two sides. By simple beam theory, this load may be idealized to concentrated loads, 750 kips at the intersection with longitudinal No. 5 and 7, and 1,000 kips at No. 6.

By the uncoupling and recoupling procedure, the boundary forces acting upon the transverse members are calculated as indicated in Table 3-2. Note that the boundary forces, i.e., the reactions from the longitudinals, are quite different from the external loads at the same node points. The maximum difference is more than 18 per cent. Using these boundary forces, the stresses inside the transverses can be calculated by the separate two-dimensional analysis. The results of the stresses within the web frames obtained from the transverse strength program are compared with those by the three-dimension analysis by EASE/CDC in Figure 3-9.

Table 3-1. Dominant Boundary Forces due to Two Different Stiffnesses for Oil-Tight Bulkheads.

Longitudinal	Component	Stiffness Factor p=5.6 (actual)	Stiffness Factor p=2.64
1-10	Y	69610	69610
11-22	Y	-50560	-50560
23	Y	-14.12*	-9.09*
24	Y	69610	69610
25	Y	-50560	-50560
26	Y	5047	5047
27	Y	5000	5000
28	Y	4600	4600
29	Y	4200	4200
51	X	-47470	-47470
52	X	-43130	-43130
53	X	-36330	-36330
54	X	-32550	-32550
55	X	-28960	-28960
56	X	-26620	-26620
57	X	-26620	-26620
58	X	-24600	-24600
59	X	-24600	-24600
60	X	-24600	-24600

For loading condition 5 , "JOHN A. MCCONE"

*Values are insignificant

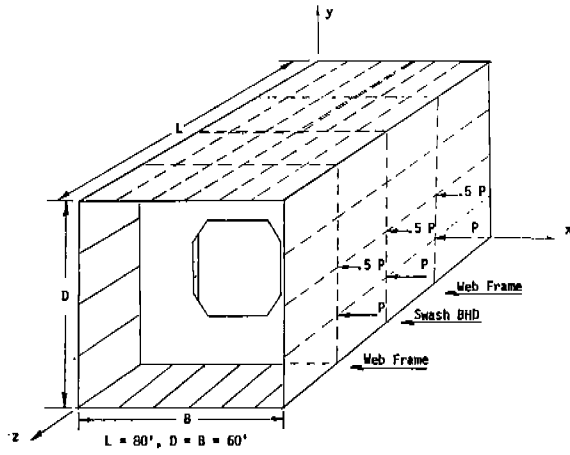

Fig. 3-5A. Simple Box Girder

Fig. 3-5B. External Loads on the Transverses $P = 1000$ kips
 Loads at Bottom of Swash $BHD = 2000$ kips

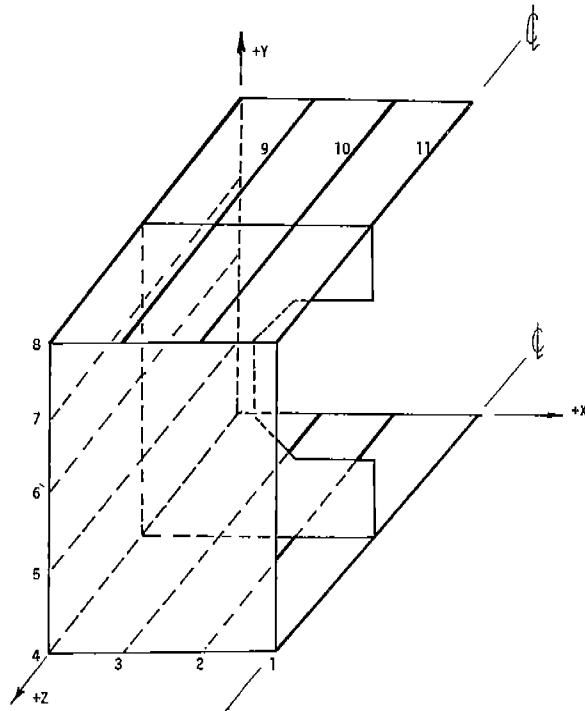
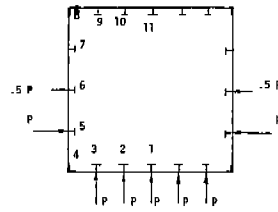
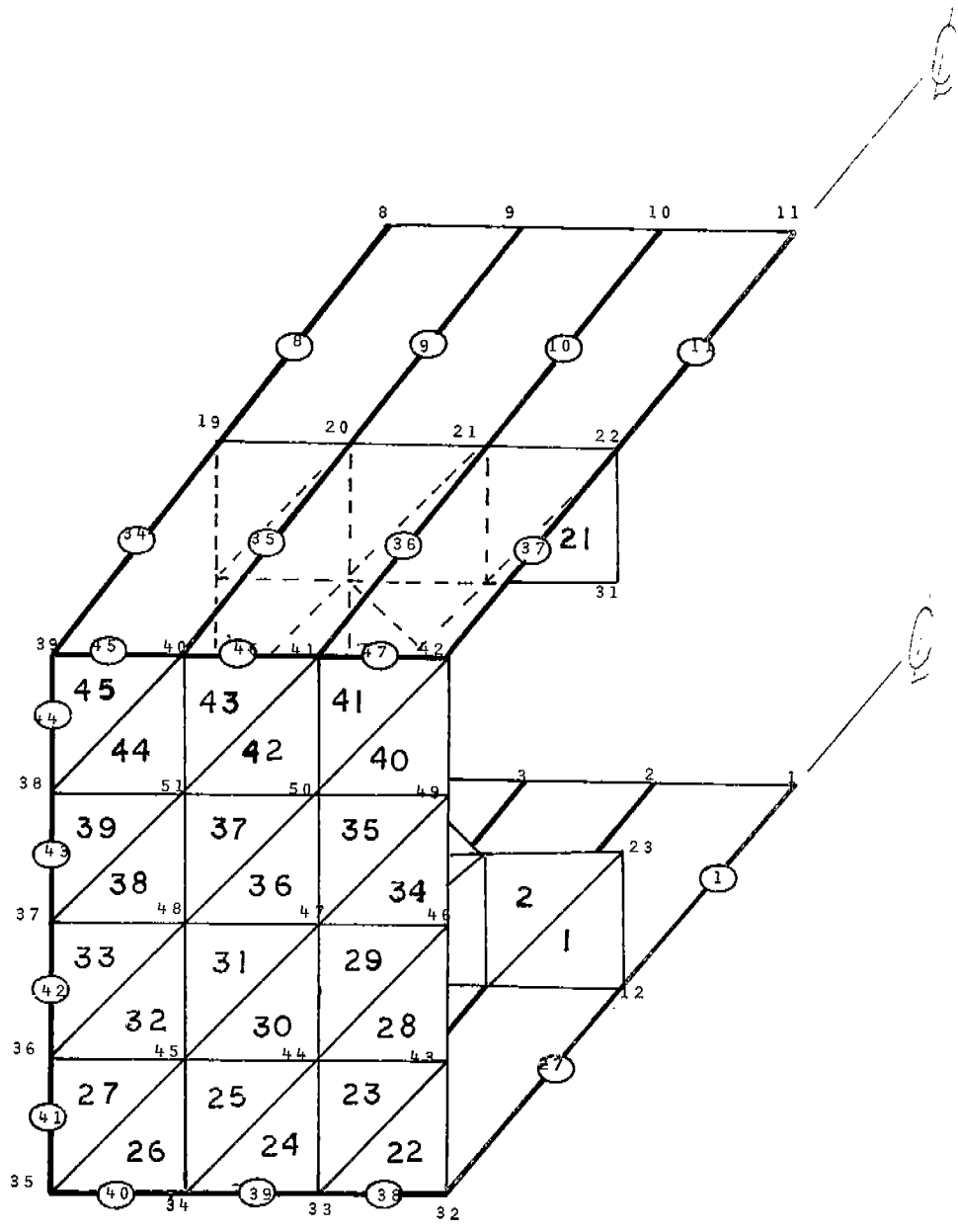
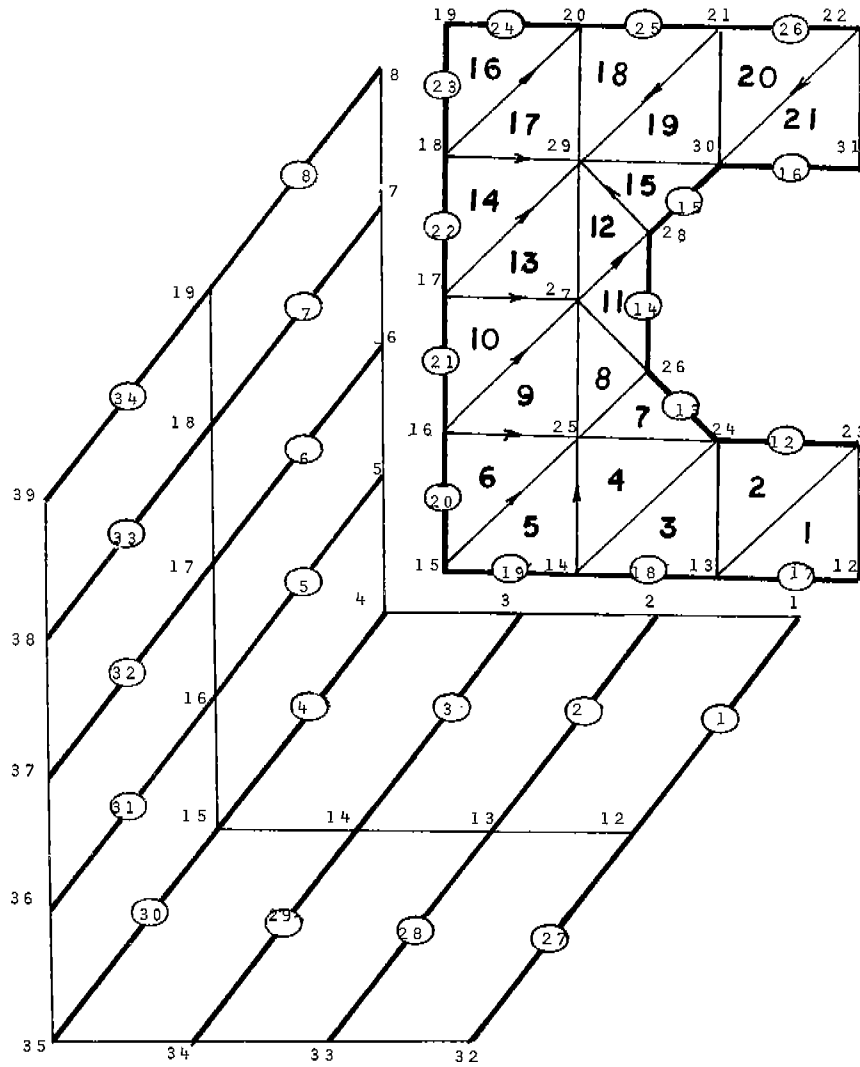

Fig. 3-6. One Quarter of Box Girder
 With One Swash Bulkhead and
 One Web Frame



- ④ indicates beam element number 41
- 36** indicates membrane element number 36

Fig. 3-7. Part I of Beam and Triangular Elements for Sample Box Girder Analysis



- ④ indicates beam element number 4
12 indicates membrane element number 12

Fig. 3-8. Part II of Beam and Triangular Elements for Sample Box Girder Analysis

Table 3-2. Boundary Forces on Transverses in kips

No. of longls.	Web Frame 1		Swash BHD		Web Frame 2	
	Fx	Fy	Fx	Fy	Fx	Fy
1	0.-	-506.0	0.-	-989.8	0.-	-506.
2	1.0	-1021.	-1.3	-1968.	1.0	-1021.
3	1.6	-1022.	-2.1	-1967.	1.6	-1022.
4.	20.8	0.	-26.5	0.	20.8	-0.
5.	-997.5	763.6	-1003.	1480.	-997.5	763.6
6.	-500.	1184.	-500.	1745.	-500.	1184.
7	0.4	761.7	-.7	1482	.4	761.7
8.	-8.0	-27.4	9.8	36.	-7.9	27.4
9.	-.7	-1.0	.9	-1.4	-.7	-1.0
10.	-.4	.3	.5	-.3	-.4	.3
11	0.	.7	0.	-1.0	0.	.7

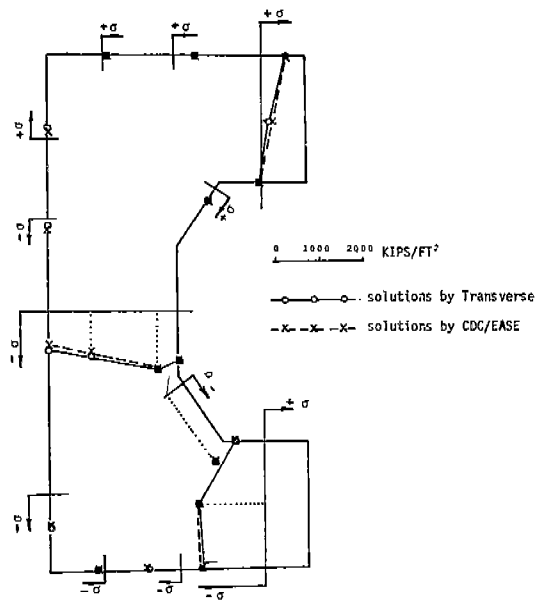

Fig. 3-9. Normal Stresses on Transverse No. 1.

CORRELATION OF THEORETICAL STRESSES WITH STRAIN GAUGE EXPERIMENTS

Solutions obtained by the methods presented in this paper have been compared with strain gauge readings from the full scale experiments of a 200,000 ton tanker. The loading conditions are indicated in Fig. 4-1.

Comparisons between experimental and analytical results are often difficult to make because the theoretical approaches are based upon idealized conditions while actual experiments reflect the real, imperfect structure. The full scale tests were conducted two years ago, and some of the data needed for closer comparisons is no longer available. For example, there is no record of the water head for the 100 per cent full tank loading conditions. The tank capacities shown in the drawings are, in general, larger than those recorded during the experiments. Since the deck of this particular tanker at the longitudinal bulkheads is about 1.15 meters higher than at the edges, there is some upward pressure acting upon the deck when the wing tank is 100 per cent full. The magnitude of this pressure can be determined only if the actual water head is known. This possible upward pressure on the deck is not considered in the analysis, even though the effect of this pressure can be quite great.

Part of the calculated results are plotted in Figure 4-2 through 4-6. Due to the discretization error, the stress of one element at the boundary is, in general, not the same as the stress of another element at the same boundary. For some locations this discontinuity is small, as shown in elements between Column 18 and 19, Figure 4-2. For some locations of great stress concentrations, this discontinuity may be large; the normal stresses in the elements between Row 19 and 20 reveal large discontinuities between the elements at the boundaries along Column 12 and Column 13, and indicates that smaller elements are desirable for this area. Since the stress distribution must be continuous, the common practice is to determine the average value at the boundaries to produce a continuous distribution, as illustrated in Figure 4-2. Figure 4-7 shows the finite element mesh used.

With few exceptions, the correlations between the computed and measured stresses are very good. In some cases, the discrepancy between the two gauges at a given location is greater than the computed result. Furthermore, the computed results are generally closer than those computed by other methods.

The large discrepancies in the upper part of the web frame and the deck beam may be due to the upward pressure of the tanks due to a water head above the decks. This pressure has not been taken into consideration because of lack of data. Also, a finer mesh for locations near the brackets and corners may be necessary for more accurate results.

Because of a limitation in the present input subroutine, the elements generated around the corners are not exactly the same as existing in the real structure, particularly at the wing tank corner near the longitudinal bulkhead. This has the effect of increasing the stress concentration at these locations as is indicated by the results.

Full Load Condition: draft = 62' - 4.75", trim = 0' - 0"

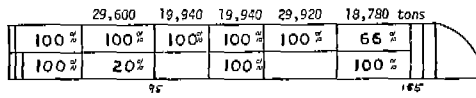

A. Loading Condition Number 5, Reading Number 3

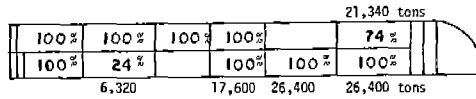

B. Loading Condition Number 5, Reading Number 4

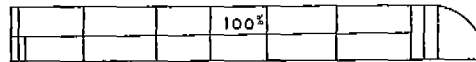

C. Loading Condition Number 8, Reading Zero

Fig. 4-1. Loading Conditions for "JOHN A. MCCONE"

Note: Figures inside tanks represent percent full capacity; figures outside tanks represent given capacity in tons.

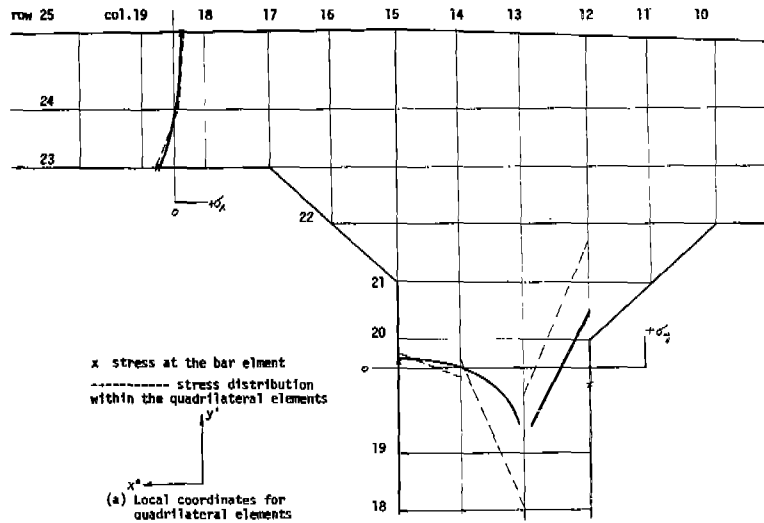

Fig. 4-2. Discontinuous Stress Distribution from the Output

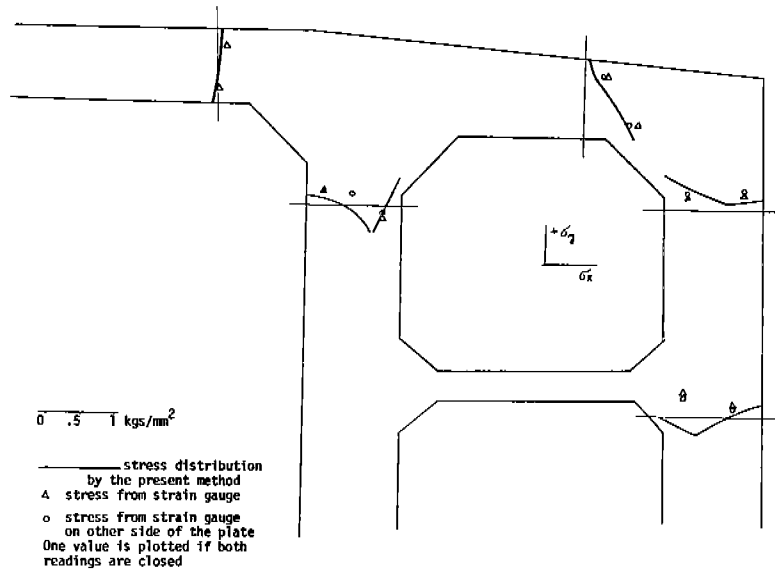

Fig. 4-3. Normal Stresses on Web Frame No. 127 for Load Condition 5

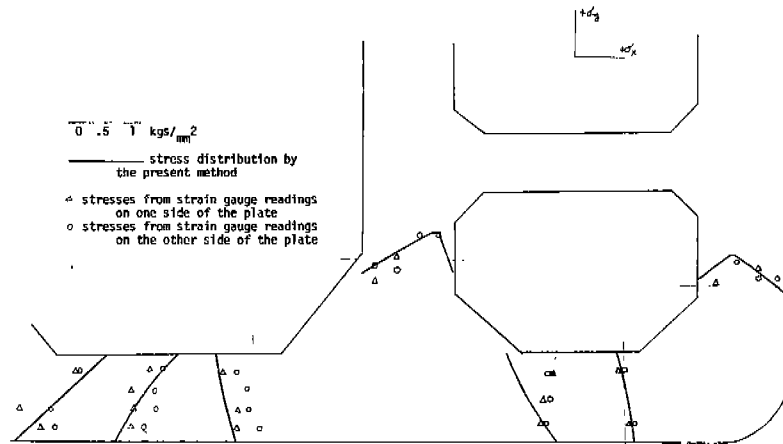

Fig. 4-4. Normal Stresses on Web Frame No. 127 for Load Condition 5

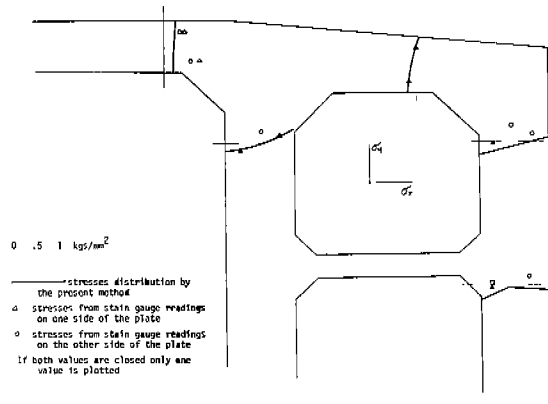

Fig. 4-5. Normal Stresses on Web Frame No. 127 for Load Condition 6

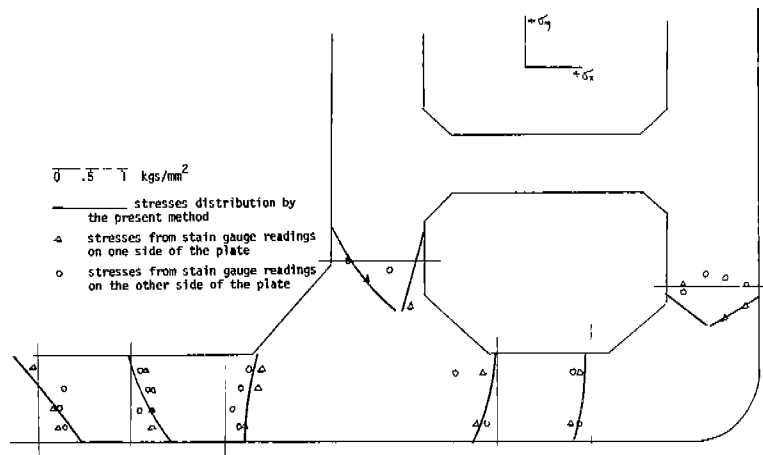

Fig. 4-6. Normal Stresses on Web Frame No. 127 for Load Condition 6

Finite Element Grid Definition for Transverse Frame

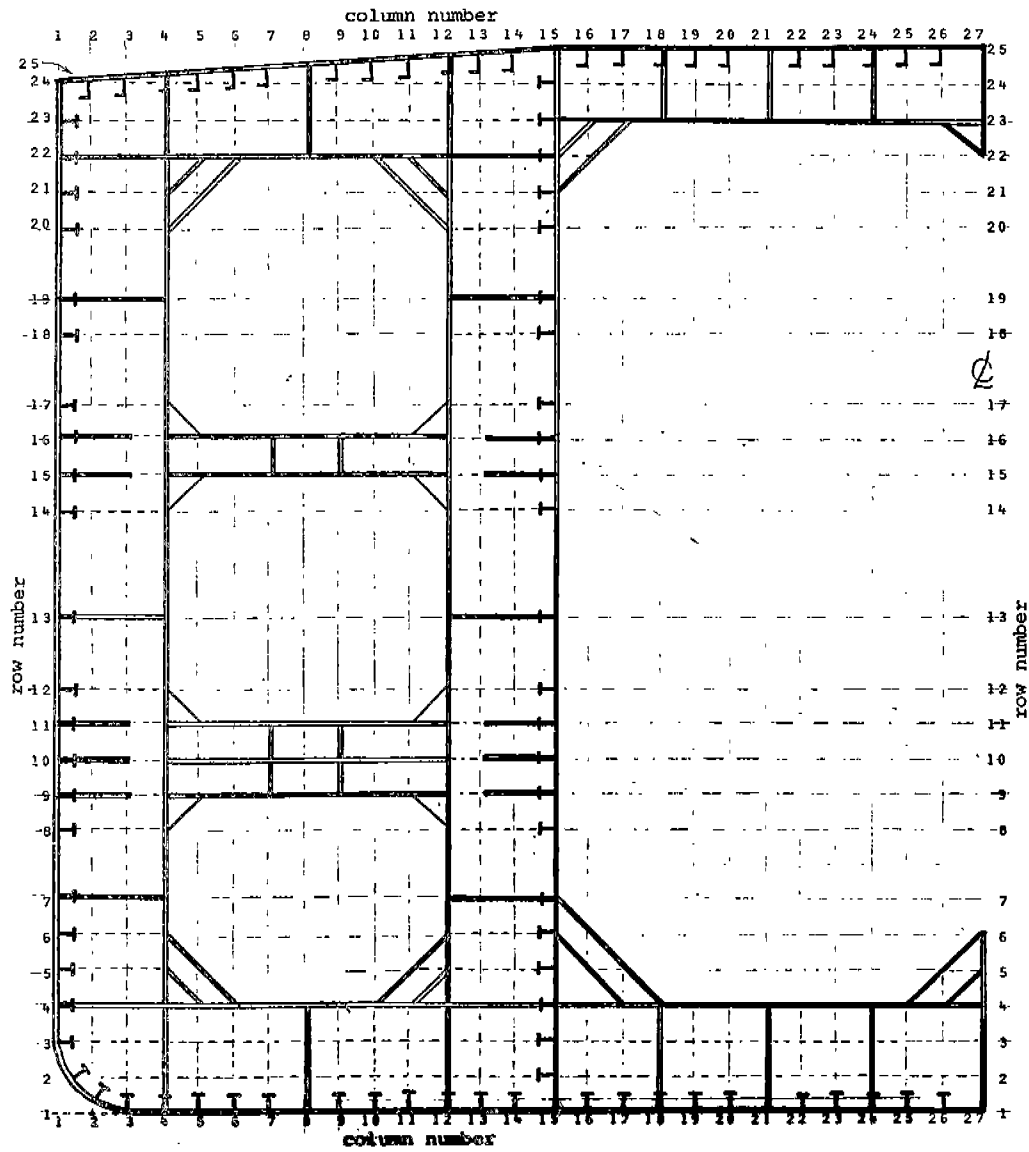

Fig. 4-7. Element Mesh for the Sample Calculations

The computer time required to do the analysis for one loading condition was 129 central processor seconds (1,044 system seconds, which includes input/output) on the Control Data Corporation's 6600 computer. The transverse analysis model included 29 transverses (699 quadrilateral and triangular plate and bar elements) and 95 longitudinals. This model would then be equivalent to one comprising of about 23,000 finite elements.

Much of the effort required for data preparation is conducted automatically inside the computer program which receives only a minimum amount of input to define the geometry of the structure and the loadings. This feature not only reduces the time needed for data preparation, but also eliminates many of the possible input errors. Furthermore, each of the required input data cards is checked by the program for possible errors. The computations are stopped automatically upon detection of any error and appropriate diagnostic statements are printed out for the engineer.

The most difficult part of the input is the loading definition, for the external loads must be accurately distributed onto the longitudinals. This program does allow the user to input these forces in great detail, and no idealization of the loading is necessary. Input preparation for a transverse strength analysis requires about two to three man-weeks, depending upon the complexity of the loading condition. Much of the manual efforts for defining these loadings could well be generated by a special routine adapted to the present computer program. Such a routine would then require only a very general description of the loads involved; the routine then would develop the detail needed for the analysis.

Since the analysis consumes relatively little computer expense and produces quite accurate stress solutions nevertheless, this new technique could be incorporated within a true design program. To date, a full-scale stress analysis has been reserved for final structural checking purposes only.

REFERENCES

1. Egil Abrahamsen "Recent Developments in the Practical Philosophy of Ship Structural Design." Trans. SNAME, 1967
2. Egil Abrahamsen "Structural Design Analysis of Large Ships" Trans. SNAME 1969
3. W. J. Roberts, "Strength of Large Tankers", No. 55 Lloyd's Register of Shipping, London, England, January 1970
4. O. C. Zienkiewicz and Y. K. Cheung "The Finite Element Method in Structural and Continuum Mechanics" McGraw-Hill Publishing Co. Limited, London-New York, 1967
5. Ivan Holand and Kolbein Bell "Finite Element Methods" Tapir, 1969
6. G. Vedeler, "Grillage Beams in Ships and Similar Structures" Grondahl & Son, Oslo, 1945
7. M. Hetenyi, "Beams on Elastic Foundation" The University of Michigan Press, 1946
8. Richard Nielsen, Jr., and Finn C. Michelsen, "Grillage Structure Analysis Through Application of the Laplace Transformation" Trans. SNAME, 1965
9. P. Y. Chang "A Simple Method for Elastic Analysis of Grillages" Journal of Ship Research, Vol. 12, No. 2, June 1968
10. H. A. Kamel, W. Birchler, D. Liu, J. W. McKinley, & W. R. Reid "An Automated Approach to Ship Structure Analysis" Trans. SNAME 1969
11. A Bulletin Published by Lloyd's Register of Shipping. No. 21, 1969
12. Masahiro Mori, "On Transverse Strength of Oil Tankers", Hiroshima Technical Institute, Jan. 1968
13. John Vasta "Lessons Learned from Full Scale Ship Structural Tests" Trans. SNAME Vol. 66. pp. 165-203, 1958
14. Eivold M. Q. Roren "Transverse Strength of Tankers-Finite Element Applications" European Shipbuilding, Part I, No. 3, Part II, No. 4, 1968
15. S. Kendrick, "The Structural Design of Supertankers" RINA, 1970
16. Thein Wah, "A Guide for the Analysis of Ship Structures", U.S. Department of Commerce, 1960

17. M. Stein and R. W. Fralich, "Critical Shear Stress of Infinitely Simply Supported Plate with Transverse Stiffeners", NACA TN 1851, 1949
18. J. H. Johnson and R. G. Noel, "Critical Bending Stress for Flat Rectangular Plates" *Journal of Aero. Science*, Vol. 20, p. 535, August, 1953
19. P. O. Araldsen, G. Holtmark, and E. M. O. Roren, "Analysis of Oil Tanker by SESAM-69". Presented at seminar on the practical application of the finite element method, Trondheim, Norway, Jan. 1971.
20. J. R. Paulling, Jr., "The Analysis of Complex Ship Structures by the Finite Element Technique" *Journal of Ship Research*, Dec. 1964, pp 1-14
21. G. O. Thomas and J. H. Ma "User Manual for the Finite Element Program of Structural Analysis" NSRDC Report 2712, April 1968.

APPENDIX A: LONGITUDINAL STRENGTH OF LARGE SHIPS

Abbreviations and Nomenclature

B	The width of the ship's hull
D	The depth of the ship's hull
L	The length of the ship's hull
R_i^α	The reaction between the α^{th} transverse and the i^{th} prime longitudinal member
a	The width of the wing tank
b	Half width of the central tank
K_{ij}^α	The influence coefficient of the α^{th} transverse while the transverse is supposed to be simply supported at both ends
$W_i(Z_\alpha)$	Deflection of the α^{th} transverse at the intersection with the longitudinal bulkheads ($i=2$) or side shells ($i=1$)
d_2^α	The deflection of the transverse at the intersections of the longitudinal bulkheads subjected to the given uniform load q_w, q_c when this transverse is simply supported at both ends.
q_w^α, q_c^α	Uniform load on the α^{th} transverse in the wing tank and central tank respectively.
Q^α	Total load upon the α^{th} transverse.

GRILLAGE ANALYSIS FOR LONGITUDINAL STRENGTH

Consider the transverse members (transverse bulkheads and web frames) as short deep beams acted upon by the symmetrical loading system as shown in the following figure:

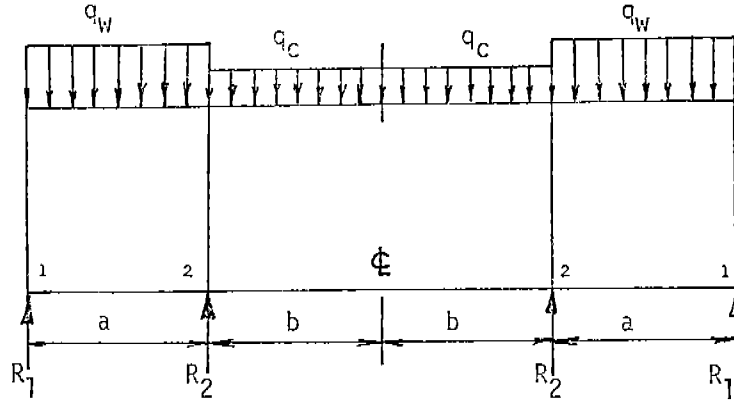

Figure A-1

Let k_{ij}^α be the influence coefficients of the α^{th} transverse, and d_i^α be the deflection at i due to external loads at the α^{th} transverse. Then,

$$W_2(z_\alpha) - W_1(z_\alpha) = d_2^\alpha - k_{22}^\alpha R_2^\alpha \quad (\text{A-1})$$

Solving for R_2^α ,

$$R_2^\alpha = \frac{1}{k_{22}^\alpha} [d_2^\alpha + W_1(z_\alpha) - W_2(z_\alpha)],$$

where k_{22}^α and d_2^α can be obtained by the beam theory. Since the loading is symmetrical, R_1^α can be calculated from the following:

$$R_1^\alpha = \int_0^a q_W(x) dx + \int_0^b q_C(x) dx - R_2^\alpha,$$

or

$$R_1^\alpha = Q^\alpha - R_2^\alpha \quad (\text{A-2})$$

Treating the prime longitudinal members as shear beams, the influence coefficients associated with the intersections of the transverse members can be obtained from beam theory. Let $A_{\alpha\beta}$ and $B_{\alpha\beta}$ be the influence coefficients for the side shell and longitudinal bulkheads respectively. Thus,

$$w_2(z_\alpha) = \sum_{\beta=1}^n A_{\alpha\beta} R_1^\beta \quad (\text{A-3})$$

$$w_1(z_\alpha) = \sum_{\beta=1}^n B_{\alpha\beta} R_2^\beta \quad (\text{A-4})$$

Combining equations (A-1), (A-2), (A-3), and (A-4),

$$\sum_{\beta=1}^n A_{\alpha\beta} (Q^\beta - R_2^\beta) - \sum_{\beta=1}^n B_{\alpha\beta} R_2^\beta = d_2^\alpha - k_{22}^\alpha R_2^\alpha \quad (\text{A-5})$$

The reactions between the longitudinal bulkheads, R_2^α , can then be solved from equation (A-5). With R_2^α known, R_1^α can be obtained from equation (A-2). With both of these reactions known, the bending moments and deflections of the longitudinal and transverse members can be calculated with beam theory.

Since both the cross-sections of the prime longitudinals and of the transverses may not be uniform along their respective lengths, the method of transfer matrices is a more convenient means of calculating the influence coefficients.

APPENDIX B: TRANSVERSE STRENGTH AS A PLAIN STRESS PROBLEM

Abbreviations and Nomenclature

u, v	Displacement in the x, y -direction
X, Y	Concentrated forces in the x, y -direction
ν	Poisson's ratio
E	Young's modulus
s	Coordinate along a boundary
n_x, n_y	Components of a unit normal on a boundary
f_x, f_y	Components of boundary forces in the x, y -direction
L, B	Differential operators
λ_i	The i^{th} eigenvalue
$[\lambda]$	Diagonal matrix with eigenvalues λ_i as diagonal elements
C_{ij}	Elements of the unitary matrix C
C_{ij}^t	Elements of the transpose matrix of C
$\bar{\lambda}$	Elasticity constant
V	Displacement vector
F	Boundary force vector
P_i	Stiffness factor for the i^{th} transverse
$\gamma_{x\alpha}, \gamma_{y\alpha}$	Stiffness factor for the α^{th} longitudinal in the x, y -direction
x, y	Coordinates in the transverse plane
z	Coordinate along the length of the ship
$d_{x\alpha}^i, d_{y\alpha}^i$	Deflection of the α^{th} longitudinal at the intersection with the i -th transverse in the x, y -directions due to externally applied loads
$A_{x\alpha}^{ij}, A_{y\alpha}^{ij}$	Influence coefficients for the α^{th} longitudinal associated with the intersections of the i -th and the j -th transverses in the x, y -directions
A^{ij}	Influence coefficients of the one longitudinal that is used for the standard.

THE TRANSVERSES OF TANKERS:

The transverses of tankers may be treated as two-dimensional elastic bodies with the boundary S as shown by the solid lines in Figure B-1 below.

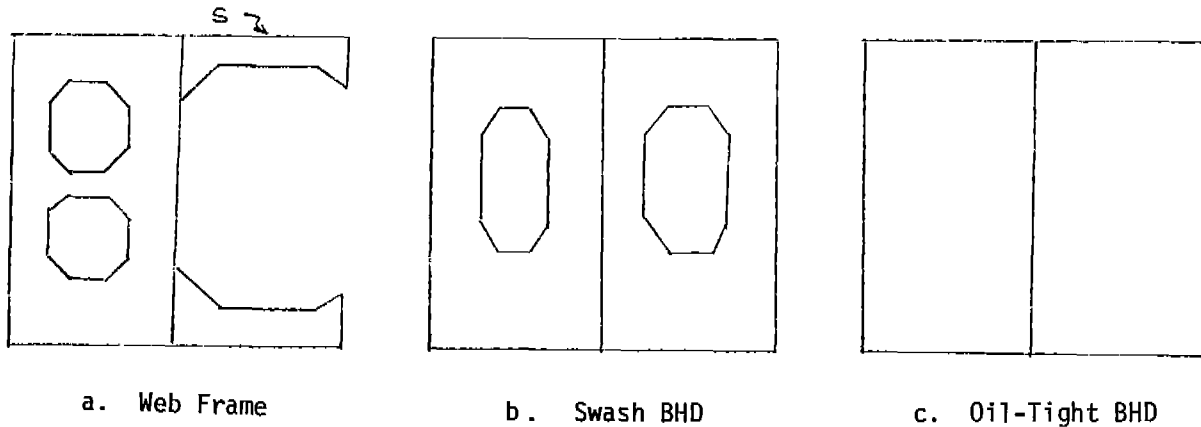

Figure B-1. Typical Transverses

Let B be an operator relating the boundary deformation V of a transverse to the boundary forces F, and L be an operator governing the deformation within the boundary of the transverses, then the deformation V must satisfy the following equations.

$$LV = 0 \quad (B-1)$$

$$BV = F \quad \text{at the boundary } S \quad (B-2)$$

$$V = V \quad \text{at the boundary } S \quad (B-3)$$

OR:

$$\begin{pmatrix} L_{uu} & L_{uv} \\ L_{vu} & L_{vv} \end{pmatrix} \begin{pmatrix} u \\ v \end{pmatrix} = \begin{pmatrix} 0 \\ 0 \end{pmatrix} \quad (B-4)$$

$$\begin{pmatrix} B_{11} & B_{12} \\ B_{21} & B_{22} \end{pmatrix} \begin{pmatrix} u \\ v \end{pmatrix} = \begin{pmatrix} f_x \\ f_y \end{pmatrix} \quad \text{at } S \quad (B-5)$$

$$u = \tilde{u} \quad (B-6)$$

$$v = \tilde{v} \quad \text{at } S$$

The transverses are acted upon by the reaction forces from the longitudinals; these boundary forces are applied along the deck, bottom, shell, and longitudinal bulkhead seams. Usually within the parallel mid-body of a tanker, there is a one-to-one correspondence of longitudinals intersecting the transverses along these boundary lines for all transverses within the mid-body section. Hence, the boundary lines of all transverses are the same. The only difference between different transverses is their stiffness.

Assume that the stiffnesses of these transverses differ by a scalar factor. If B is the operator for one web frame, $L^i B^i$ can be expressed as

$$\begin{aligned} B^i &= P_i B & (B-7) \\ L^i &= P_i L \end{aligned}$$

where P_i is a scalar factor

For the i^{th} transverse, equations (B-4) and (B-5) reduce to

$$\begin{bmatrix} L_{uu} & L_{uv} \\ L_{vu} & L_{vv} \end{bmatrix} \begin{pmatrix} P_i u^i \\ P_i v^i \end{pmatrix} = \begin{pmatrix} 0 \\ 0 \end{pmatrix} \quad (B-8)$$

and

$$\begin{bmatrix} B_{11} & B_{12} \\ B_{21} & B_{22} \end{bmatrix} \begin{pmatrix} P_i u^i \\ P_i v^i \end{pmatrix} = \begin{pmatrix} f_x^i \\ f_y^i \end{pmatrix} \quad \text{on } S$$

The equations above imply that for the boundary force F ,

$$u^i = \frac{1}{P_i} u, \quad v^i = \frac{1}{P_i} v, \quad (B-9)$$

where u, v are the boundary displacements of a given standard transverse where the stiffness is known precisely. Equations (B-9) are not exactly true, but the errors caused by their use are negligible.

LONGITUDINALS AS CONTINUOUS BEAMS:

Let $d_{x\alpha}^i$ be the deflection in the x-direction of the α^{th} longitudinal at its intersection with the i^{th} transverse. The actual deflection, u_{α}^i at $z = z_i$, of this longitudinal can be expressed by the following:

$$u_{\alpha}^i = d_{x\alpha}^i - \sum_{j=1}^n A_{x\alpha}^{ij} \chi_{\alpha}^j, \quad (\text{B-10})$$

where $A_{x\alpha}^{ij}$ is the influence coefficient for the i^{th} longitudinal, and χ_{α}^j is the supporting force of the j^{th} transverse.

Since all the longitudinals are assumed to be similar in bending stiffness, A_{ij} can be expressed in the following way:

$$\gamma_{x\alpha} A_{x\alpha}^{ij} = A^{ij}, \quad (\text{B-11})$$

where $\gamma_{x\alpha}$ is a scalar factor and A^{ij} is the influence coefficient for a given standard longitudinal. Combining with equation (B-11), (B-10) can be reduced to

$$\sum_{j=1}^n A^{ij} \chi_{\alpha}^j = \gamma_{x\alpha} (d_{y\alpha}^i - u_{\alpha}^i) \quad (\text{B-12})$$

Similarly for deflections in the y-direction,

$$\sum_{j=1}^n A^{ij} \gamma_{\alpha}^j = \gamma_{y\alpha} (d_{y\alpha}^i - v_{\alpha}^i) \quad (\text{B-13})$$

For equilibrium and compatibility of the intersections, the following is a necessary condition:

$$\begin{pmatrix} u^i \\ v^i \end{pmatrix} \text{ in (B-8)} \cong \begin{pmatrix} u^i \\ v^i \end{pmatrix} \text{ in (B-12) and (B-13)} \quad (\text{B-14})$$

$$\begin{pmatrix} f_x^i \\ f_y^i \end{pmatrix} \text{ in (A-8)} = \begin{pmatrix} X_\alpha^i \\ Y_\alpha^i \end{pmatrix} \text{ in (B-12) and (B-13)} \quad (\text{B-15})$$

Combining equations (B-12) and (B-15),

$$\sum_{j=1}^n B_{11} A^{ij} P_j u^j + B_{12} A^{ij} P_j v^j = \gamma_{x\alpha} [d_{x\alpha}^i - u^i] \quad (\text{B-16})$$

The above reveals a coupling relationship between the boundary displacements of different transverses. Let

$$\bar{u}^j = P_j^{\frac{1}{2}} u^j \quad \text{and} \quad \bar{v}^j = P_j^{\frac{1}{2}} v^j \quad (\text{B-17})$$

and multiply equation (B-16) by $P_i^{\frac{1}{2}}$:

$$\sum_{j=1}^n B_{11} P_i^{\frac{1}{2}} A^{ij} P_j \bar{u}^j + B_{12} P_i^{\frac{1}{2}} A^{ij} P_j \bar{v}^j = \gamma_{x\alpha} [P_i^{\frac{1}{2}} d_{x\alpha}^i - \bar{u}^i] \quad (\text{B-18})$$

Since $[P_i^{\frac{1}{2}} A^{ij} P_j^{\frac{1}{2}}]$ is symmetrical, there exists a unitary matrix C such that

$$C^t C = I \quad \text{and} \quad C^t P A P C = [-\lambda] \quad (\text{B-19})$$

Let $\bar{u}^i = C_{ij}^t \tilde{u}^j$, and multiply equation (B-18) by C_{ij}^t :

$$B_{11}\lambda_i \tilde{u}^i + B_{12}\lambda_i \tilde{v}^i = \gamma_{x\alpha} [C_{ij}^t p_{jx\alpha}^{\frac{1}{2}j} - \tilde{u}^i] \quad (\text{sum on } j) \quad (\text{B-20})$$

Similarly,

$$B_{21}\lambda_i \tilde{u}^i + B_{22}\lambda_i \tilde{v}^i = \gamma_{y\alpha} [C_{ij}^t p_{jy\alpha}^{\frac{1}{2}j} - \tilde{v}^i] \quad (\text{B-21})$$

Hence at $S = S_\alpha$,

$$\begin{pmatrix} B_{11} & B_{12} \\ B_{21} & B_{22} \end{pmatrix} \begin{pmatrix} \tilde{u}^i \\ \tilde{v}^i \end{pmatrix} = \begin{pmatrix} \bar{f}_{x\alpha}^i \\ \bar{f}_{y\alpha}^i \end{pmatrix} - \frac{1}{\lambda_i} \begin{pmatrix} \gamma_{x\alpha} \tilde{u}^i \\ \gamma_{y\alpha} \tilde{v}^i \end{pmatrix}, \quad (\text{B-22})$$

where

$$\bar{f}_{x\alpha}^i = \frac{1}{\lambda_i} C_{ij}^t p_{jx\alpha}^{\frac{1}{2}j} \quad (\text{sum on } j)$$

$$\bar{f}_{y\alpha}^i = \frac{1}{\lambda_i} C_{ij}^t p_{jy\alpha}^{\frac{1}{2}j} \quad (\text{sum on } j)$$

Similar transformations reduce the set of equations (B-4) for the transverses to the following:

$$\begin{pmatrix} L_{uu} & L_{uv} \\ L_{vu} & L_{vv} \end{pmatrix} \begin{pmatrix} \tilde{u}^i \\ \tilde{v}^i \end{pmatrix} = \begin{pmatrix} 0 \\ 0 \end{pmatrix} \quad (\text{B-23})$$

For homogeneous boundary conditions, the boundary restraints reduce to zero:

$$\begin{cases} \tilde{u}^i = 0 \\ \tilde{v}^i = 0 \end{cases} \quad (\text{B-24})$$

From equations (B-22), (B-23), and (B-24), this is a plain stress problem for an equivalent two-dimensional elastic body to which the boundary forces $\bar{f}_{x\alpha}^i, \bar{f}_{y\alpha}^i$, ($\alpha = 1, \dots, m$ where m is the number of longitudinals) are applied. This body has the boundary constraints as defined by equation (B-24) and is supported by a set of concentrated springs at $S = S_\alpha$ which has spring constants equal to $\gamma_{x\alpha} / \lambda_i, \gamma_{y\alpha} / \lambda_i$. This problem can be solved directly by a two-dimensional finite element approach.

Let the number of transverses be n and the number of longitudinals be m . Let each transverse include k -degrees of freedom. This is a problem of $2nk$ -degrees of freedom using this new method. By treating transverses as super-elements, the problem is reduced to only n problems, each of k -degrees of freedom.

After $\tilde{u}_\alpha^i, \tilde{v}_\alpha^i$ are calculated, the real displacements on the boundary can be obtained by the reverse transformations:

$$\begin{aligned} u_\alpha^i &= P_i^{-\frac{1}{2}} C_{ij} \tilde{u}_\alpha^j & (\text{sum on } j) \\ v_\alpha^i &= P_i^{-\frac{1}{2}} C_{ij} \tilde{v}_\alpha^j & (\text{sum on } j) \end{aligned} \quad (\text{B-25})$$

With u_α^i and v_α^i , the boundary forces can be calculated from equations (B-12) and (B-13). With these boundary forces known, the real displacements and stresses of any transverse can be calculated by a standard two-dimensional finite element method. The finite element program used as subroutine was developed by Pauling²⁰, and extended by Thomas and Ma.²¹

APPENDIX C - THE STIFFNESS OF THE LONGITUDINALS

The deflection of longitudinals.

The load upon each longitudinal is defined as that load acting on the area supported by the longitudinal. For most practical purposes, the loads within one frame space may be assumed uniform with sufficient accuracy.

Let $q_{i\alpha}$ be the loads and $I_{i\alpha}$ be the stiffness of the α^{th} longitudinal in i^{th} spacing, and let W, θ, M, V $_i$ be the deflection, slope, bending moment, and shear force at the intersection with the i^{th} transverse. Then from beam theory.

$$\begin{bmatrix} W \\ 0 \\ M \\ V \\ 1 \end{bmatrix}_{i+1,\alpha} = \begin{bmatrix} 1 & -z_{i+1} & -\frac{z_{i+1}^2}{2EI} & -\frac{z_{i+1}^3}{6EI} & \frac{q_{i+1}z_{i+1}^4}{24EI} \\ 0 & 1 & \frac{z_{i+1}}{EI} & \frac{z_{i+1}^2}{2EI} & -\frac{q_{i+1}z_{i+1}^3}{6EI} \\ 0 & 0 & 1 & z_i & -q_{i+1}\frac{z_{i+1}^2}{2} \\ 0 & 0 & 0 & 1 & -q_{i+1}z_{i+1} \\ 0 & 0 & 0 & 0 & 1 \end{bmatrix} \begin{bmatrix} W \\ 0 \\ M \\ V \\ 1 \end{bmatrix}_{i,\alpha} \quad (C-1)$$

where z_{i+1} is the spacing, q_i is the uniform load.

α is the index for the α^{th} longitudinal.

Omitting the index α we have

$$S_{i+1} = L_{i+1} S_i$$

Therefore,

$$S_{n+1} = L_{n+1}L_n \text{ ----- } L_1 S_0$$

or
$$S_{n+1} = L S_0 \quad (C-2)$$

Since the longitudinal is simply supported,

$$W_0 = W_{n+1} = M_0 = M_{n+1} = 0 \quad (C-3)$$

and
$$\begin{bmatrix} L_{12} & L_{14} \\ L_{32} & L_{34} \end{bmatrix} \begin{bmatrix} \Theta \\ V \end{bmatrix} = \begin{bmatrix} L_{15} \\ L_{35} \end{bmatrix} \quad (C-4)$$

or
$$\begin{cases} \Theta_0 = \frac{L_{14}L_{35} - L_{15}L_{34}}{L_{12}L_{34} - L_{14}L_{32}} \\ V_0 = \frac{L_{15}L_{32} - L_{12}L_{35}}{L_{12}L_{34} - L_{14}L_{32}} \end{cases} \quad (C-5)$$

Let

$$L^i = L_i L_{i-1} \text{ ----- } L_1 \quad \text{then}$$

$$W_i = L_{12}^i \Theta_0 + L_{14}^i V_0 + L_{15}^i \quad (C-6)$$

Using the notation in Chapter II

$$d_{xi\alpha} = (L_{12}^i \Theta_0 + L_{14}^i V_0 + L_{15}^i)_\alpha \quad (C-7)$$

The indices α and x indicate that all the above equations are dealing with the α^{th} longitudinal in the x -direction.

The influence coefficients.

Let the q_{i+1} be zero and insert the following point matrix between L_{i+1} and L_i .

$$L^P = \begin{bmatrix} 1 & 0 & 0 & 0 & 0 \\ 0 & 1 & 0 & 0 & 0 \\ 0 & 0 & 1 & 0 & 0 \\ 0 & 0 & 0 & 1 & -1 \\ 0 & 0 & 0 & 0 & 1 \end{bmatrix} \quad (C-8)$$

we have

$$S_{n+1} = L S_0 \quad (C-9)$$

where $L = L_{n+1} L_n \dots L_{i+1} L_i^P \dots L_1$ (C-10)

From equation (C-5) we have θ_0 , V_0 , and from equation (C-6) we have

$$A_{ij}^{\alpha x} = (L_{12}^i \theta_0 + L_{14}^i V_0 + L_{15}^i)_{\alpha x j} \quad (C-11)$$

where the index i indicates the deflection at i due to a unit load at j of the α^{th} longitudinals.

Note that

$$A_{ij}^{\alpha x} = A_{ji}^{\alpha x} \quad (C-12)$$

Thus, only the upper half of the matrix must be calculated, and since all longitudinals are similar, only one or a few typical $A_{ij}^{\alpha x}$ and $A_{ij}^{\alpha y}$ need be computed. In general, $d_{xi\alpha}$, $d_{yi\alpha}$ must be calculated for each longitudinal unless the external loads are the same.

APPENDIX D: INFLUENCE COEFFICIENTS AND DEFLECTION
OF THE PRIME TRANSVERSE MEMBERS

Let I_i be the moment of inertia and A_i the web area of the i^{th} section of the simply supported shear beam as illustrated in Figure D-1. The influence coefficient, B_{ij} , is defined as the deflection at i due to a unit load or loads at j .

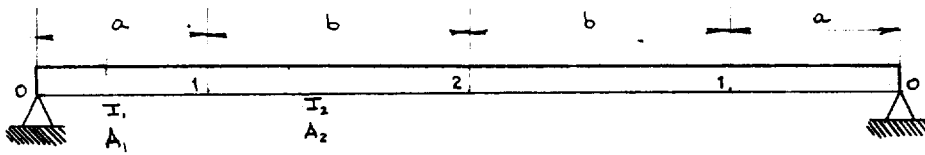

Figure D-1

Deflection due to uniform loads.

Let the load be q_1 in 0-1, q_2 in 1-2. By line solution

$$\begin{pmatrix} W \\ \theta \\ M \\ V \\ 1 \end{pmatrix}_1 = \begin{pmatrix} 1 & -a & \frac{-a^2}{2EI_1} & \left(\frac{-a^3}{6EI_1} + \frac{a}{GA_1}\right) & q_1 \left(\frac{a^4}{24EI_1} - \frac{a^2}{2GA_1}\right) \\ 0 & 1 & \frac{a}{EI_1} & \frac{a^2}{2EI_1} & \frac{-q_1 a^3}{6EI_1} \\ 0 & 0 & 1 & a & \frac{-q_1 a^2}{2} \\ 0 & 0 & 0 & 1 & -q_1 a \\ 0 & 0 & 0 & 0 & 1 \end{pmatrix} \begin{pmatrix} W \\ \theta \\ M \\ V \\ 1 \end{pmatrix}_0 \quad (D-1)$$

$$\text{Or} \quad S^1 = L^1 S^0 \quad (\text{D-1})$$

By changing the indices

$$S^2 = L^2 S^1 \quad (\text{D-2})$$

Combining (D-1) and (D-2) we have

$$S^2 = L^2 L^1 S^0 = LS^0 \quad (\text{D-3})$$

The boundary conditions are

$$W^0 = M^0 = \theta^2 = V^2 = 0$$

From equation (D-3)

$$\begin{bmatrix} L_{22} & L_{24} \\ L_{42} & L_{44} \end{bmatrix} \begin{bmatrix} \theta^0 \\ V^0 \end{bmatrix} = \begin{bmatrix} L_{25} \\ L_{45} \end{bmatrix} \quad (\text{D-4})$$

$$W^1 = L_{12}^1 \theta^0 + L_{14}^1 V^0 + L_{15}^1 \quad (\text{D-5})$$

$$W^2 = L_{12}^2 \theta^0 + L_{14}^2 V^0 + L_{15}^2 \quad (\text{D-6})$$

Influence Coefficients

In deriving influence coefficients, the transfer matrices L^1 and L^2 are the same as given above except that the elements associated with the loads vanish. In addition a point matrix is added at the location of the unit load. The point matrix is

$$\begin{pmatrix} 1 & 0 & 0 & 0 & 0 \\ 0 & 1 & 0 & 0 & 0 \\ 0 & 0 & 1 & 0 & 0 \\ 0 & 0 & 0 & 1 & -1 \\ 0 & 0 & 0 & 0 & 1 \end{pmatrix}$$

APPENDIX E - THE EFFECT OF LONGITUDINALS NOT AT THE NODAL POINTS

In any finite element analysis, the terminals of any element must be located at the nodal points. For this reason, the mesh for the transverses should contain all intersections with the longitudinals as nodal points. This requirement, however, puts a great restriction on the discretization of the transverses and therefore may be undesirable for other purposes. This appendix investigates the effect of the longitudinals located on one edge of the elements.

Triangular elements

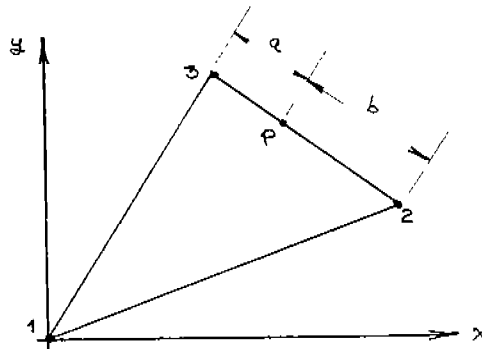

Figure E-1

For a constant stress triangular element the displacement is linear; therefore,

$$u_p = \frac{au_2 + bu_3}{a+b} \quad (E-1)$$

$$v_p = \frac{av_2 + bv_3}{a+b}$$

Any force acting at (X_p, Y_p) can be replaced by two equivalent forces at 2, and 3.

$$X_2 = \frac{a}{a+b} X_p, \quad X_3 = \frac{b}{a+b} X_p \quad (E-2)$$

Similarly

$$Y_2 = \frac{b}{a+b} Y_p, \quad Y_3 = \frac{a}{a+b} Y_p \quad (E-3)$$

Replace this longitudinal by two imaginary longitudinals at 2 and 3 as per equation (1) of Appendix B:

$$\begin{cases} u_{i2} = d_{xi2} - a_{ij}^{2x} X_{j2} \\ u_{i3} = d_{xi3} - a_{ij}^{3x} X_{j3} \end{cases} \quad (E-4)$$

The force and displacement components of these two imaginary longitudinals should be compatible and equivalent to those of the real longitudinals only if

$$\begin{cases} \frac{ad_{xi2} + bd_{xi3}}{a+b} = d_{xip} \\ a_{ij}^{2x} \left(\frac{a}{a+b}\right)^2 + \left(\frac{b}{a+b}\right)^2 a_{ij}^{3x} = a_{ij}^{px} \end{cases} \quad (E-5)$$

This equation is satisfied if

$$\begin{cases} d_{xi2} = d_{xi3} = d_{xip} \\ I_2 = \frac{a}{a+b} I, \quad I_3 = \frac{b}{a+b} I \end{cases} \quad (E-6)$$

Equation (E-6) implies that one longitudinal located in one edge of the triangular element can be replaced by two imaginary longitudinals at the nodal points of this edge if the stiffness and the load for these two imaginary longitudinals are proportional to the distance ratios of the two nodal points and the location of the actual longitudinal. I is the moment of inertia of this longitudinal located at p , and I_2 and I_3 are the respective equivalent moments of inertia at the nodal points 2 and 3.

For other types of elements with linear stresses, the displacement components are non-linear. The compatibility condition may not be satisfied, and the error involved is equivalent to that induced by replacing the element with two or more triangular elements. But for all practical purposes, this error is negligible, and as such this method of determining equivalent longitudinal is applied to all other types of elements.

$$X_n = \frac{a}{c} X_m \quad X_m = \frac{b}{c} X_n \quad (E-2)$$

APPENDIX F: THE SIMILARITY OF TRANSVERSES

The theory introduced in Chapter 3 assumes that all transverse members (web frames, oil-tight and swash bulkheads) are similar in stiffness: more specifically, the influence coefficients of one transverse are directly proportional to the corresponding coefficients of any other transverse.

Without causing too much difficulty, the theory assumes that at the very least all web frames within the mid-body section are identical. Since the similarity principal requires the use of one type of transverse as the standard against which the stiffnesses of others may be measured, the web frame is selected as this standard since it is also perhaps one of the most critical members within the ship structure.

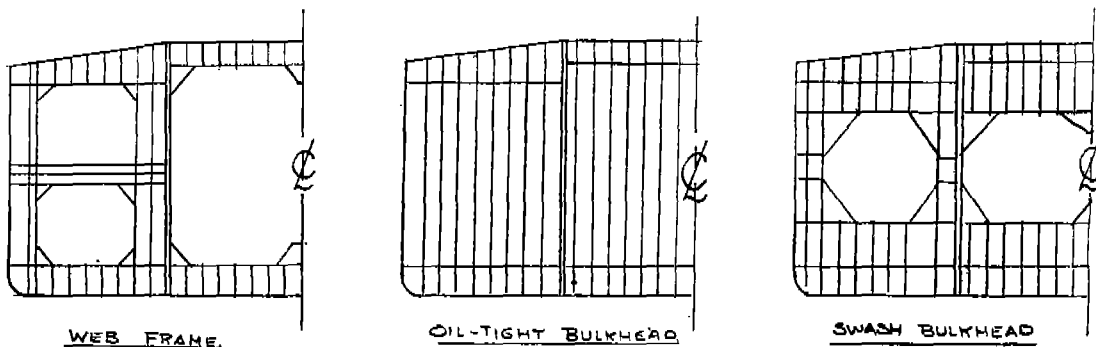

Figure F-1. Transverse Members

The relative stiffness factor (the proportionality constant) may be obtained by comparing the deflections of the bulkhead to those of the web frame when both members are acted upon by a unit load applied at the

upper corner as illustrated below.

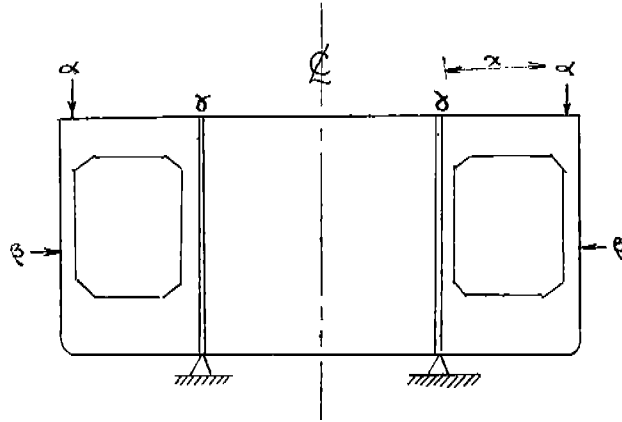

Figure F-2

Mathematically the stiffness factor, P_b , of the bulkhead is expressed as

$$P_b = \frac{d'_\alpha}{d_\alpha}, \quad (F-1)$$

where d'_α and d_α are the respective deflections at α of the web frame and the bulkhead.

As concluded from the experiments conducted by Mori¹⁷ and Roberts¹⁴, both the web frames and bulkheads may be modeled as shear beams experiencing very little bending deflection:

$$d_\alpha = \frac{x}{GA_f} \quad (F-2)$$

$$d'_\alpha = \frac{x}{GA_b}$$

where A_f and A_b are the total shear areas of the frame and bulkhead respectively, and x is the distance of the unit load from the support.

By substitution, the stiffness factor may be expressed as

$$P_b = \frac{A_b}{A_f} \quad (F-3)$$

The above provides an approximate solution for the stiffness factor, which perhaps could be more accurately resolved using a finite element analysis.

At this point the question arises as to the validity of applying this same stiffness factor to other positions of the bulkhead, for example, location β of Figure F-2. Naturally some error will occur and the extent of this inaccuracy must be established.

Let A_{ij}^α , be the influence coefficient of the α^{th} longitudinal, and let α^i be the influence of the i^{th} transverse at the intersection of this longitudinal (see Figure F-3 below). The reaction, R_i , and the actual deflection, W_i , of the intersection may be expressed as

$$W_i = L_\alpha R_i \quad (\text{F-4})$$

for the transverse, and

$$W_i = d_i^\alpha - A_{ij}^\alpha R_j \quad (\text{F-5})$$

for the longitudinal, d_i^α is the deflection of the longitudinal under external loads but treated as a simply supported beam with no support by the transverses.

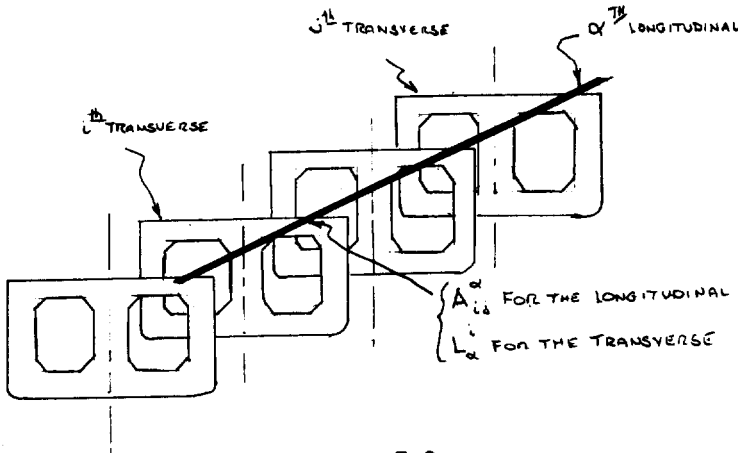

Figure F-3

Combining equations F-4 and F-5, the matrix equation yields

$$(A + \bar{L}) R = D \quad (F-6)$$

where \bar{L} is a diagonal matrix.

Since the transverse is assumed to be much stiffer than the longitudinal ($A_{ij}^{\alpha} \gg L_{\alpha}^i$) the resolved reactions may be expressed as

$$R + \left[I - \sum_{n=1}^{\infty} (-1)^{n-1} (A^{-1} I)^n \right] A^{-1} D \quad (F-7)$$

Let $\pm bL_{\alpha}^m$ be the error in the influence coefficient of the m^{th} transverse, a bulkhead. The maximum error in R_i (the i^{th} transverse) may be found to be

$$E_i = \pm bA_{im}^{-1} L_{\alpha}^m \sum_{j=1}^{n_t} A_{mj}^{-1} D_j \quad (F-8)$$

$N_t = \text{Number of the transverses}$

In terms of orders of magnitude, the ratio of R_i and E_i is approximately $\pm bA_{im}^{-1} L_{\alpha}^m$. Since this expression compares the stiffness of the longitudinal with a much greater stiffness of the bulkhead, ($A_{im}^{-1} L_{\alpha}^m$) is estimated to be less than half of one percent for a large tanker. Thus a one hundred percent error in the stiffness factor for the bulkhead would produce an error less than one per cent.

This conclusion has been validated by the analysis of the tanker, "JOHN A. MCCONE", the stiffness factor of the oil-tight bulkheads was deliberately increased by 100 percent; this change produced a maximum error within the resulting boundary forces of less than 0.5 per cent.

APPENDIX G - APPLICATION OF THIS PROGRAM FOR ORE CARRIERS AND CONTAINER SHIPS

For the analysis of ore carriers or container ships with symmetrical loads, no modifications are necessary for the transverse strength calculations.

The longitudinal or primary strength calculations, however, can accommodate symmetrical loadings only. For the stresses due to unsymmetrical loads (the horizontal bending and the twisting of the hull), additional investigations are necessary to determine the significance of these effects. The theoretical solutions for these stresses may be approached in the following manner:

Basic Assumption

The deformation of the ship's structure is sufficiently small such that the stresses due to vertical bending, horizontal bending, and twisting can be calculated separately.

Horizontal Bending

The horizontal bending can be calculated similarly as the vertical bending. The only difference is the loads.

Twisting

For the twisting stresses, the hull is treated as an open thin wall beam with braces as shown in Figure G-1.

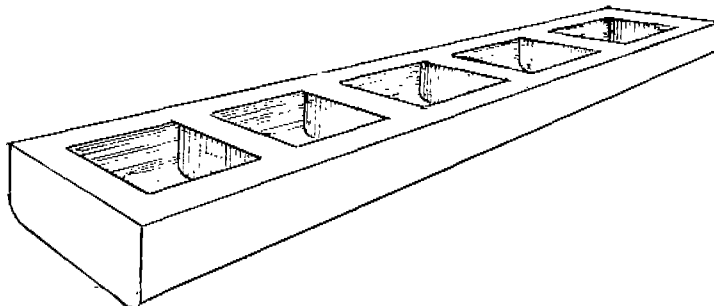

Figure G-1.

The cross section between the braces may be assumed as constant. By transfer matrix, the state variables between two stations without loads can be written as

$$\begin{pmatrix} \phi \\ \psi \\ M_B \\ M_t \\ 1 \end{pmatrix}_{i+1} = \begin{pmatrix} L_{11}, L_{12}, L_{13}, L_{14}, 0 \\ L_{21}, L_{22}, L_{23}, L_{24}, 0 \\ L_{31}, L_{32}, L_{33}, L_{34}, 0 \\ L_{41}, L_{42}, L_{43}, L_{44}, 0 \\ 0 & 0 & 0 & 0 & 1 \end{pmatrix}_i \begin{pmatrix} \phi \\ \psi \\ M_B \\ M_t \\ 1 \end{pmatrix}_i \quad (G-1)$$

or

$$S_{i+1} = L_i S_i$$

where

ϕ - the twisting angle

ψ - the derivative of the twisting angle

M_B - the bimoment

M_t - the twisting moment

L_{nj} , $i=1 - 4$, $j=1 - 4$ are given in Table G-1

$$\beta^2 = \frac{C_\psi}{C_\omega}$$

C_ψ - the torsional rigidity

C_ω - the warping rigidity

Table G-1. The Transfer Matrix (L_{ij})

1	$-\frac{\sin\beta(x-a_i)}{\beta}$	$-\frac{(1-\cos\beta(x-a_i))}{C_\omega\beta^2}$	$\frac{-\beta(x-a_i)+\sin\beta(x-a_i)}{C_\omega\beta^3}$
0	$\cos\beta(x-a_i)$	$\frac{\sin\beta(x-a_i)}{C_\omega\beta}$	$\frac{+1-\cos\beta(x-a_i)}{C_\omega\beta^2}$
0	$-\beta C_\omega \sin(x-a_i)$	$\cos\beta(x-a_i)$	$\frac{\sin\beta(x-a_i)}{\beta}$
0	0	0	1

The transfer matrix for a concentrated twisting moment, M_t , is

$$\begin{pmatrix} 1 & 0 & 0 & 0 & 0 \\ 0 & 1 & 0 & 0 & 0 \\ 0 & 0 & 1 & 0 & 0 \\ 0 & 0 & 0 & 1 & -M_t \\ 0 & 0 & 0 & 0 & 1 \end{pmatrix} \quad (G-2)$$

By the method of line solution, the global matrix is L.

where

$$\begin{aligned} S_{n+1} &= L_n, L_{n-1} \dots L_0 S_0 \\ S_{n+L} &= L S_0 \end{aligned} \quad (G-3)$$

The effect of the braces can be taken as redundant. Let Z_i be the total shear force across the middle section of the i^{th} brace as indicated in Figure G-2. The values of Z_i can be calculated by equation G-3.

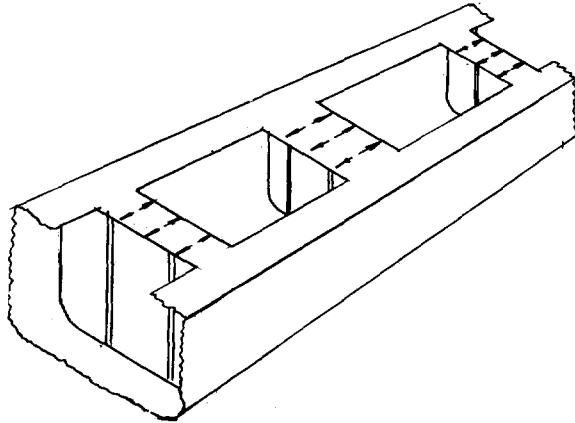

Figure G-2.

$$(\alpha_{ij} + \delta_{ij}\beta_j) Z_j + d_i = 0 \quad (G-3)$$

where

d_i - deformation at the cutout of the i^{th} brace due to external loads

$\delta_{ij} = 1$, if $i=j$, otherwise zero

α_{ij} - deformation at the i^{th} cutout due to a unit load at the j^{th} cutout

β_j - deformation at the j^{th} cutout due to the deformation of the j^{th} brace.

α_{ij} and d_i can be calculated with the transfer matrix method by treating the ship hull as a thin wall beam without braces. β_j can be calculated by shear beam theory; hence, equation G-3 may be solved directly. With Z_j known, the real deformations and stresses of the hull can be calculated by the transfer matrix method. These stresses should be added to the stresses due to vertical and horizontal bending. The significance of these additional stresses depends upon several factors: the magnitude of the possible skew loads upon the hull; the dimensions of the openings relative to the dimensions of the ship; and the design of the braces.

From the above theory, stress concentrations will occur at the corners of the openings. Thus, a finite element analysis of this portion of the structure may be required.

APPENDIX H: ANALYSIS OF PART OF THE HULL

The general theory introduced by the uncoupling technique can be applied for analysis of part of the hull. A partial hull model is desirable for several reasons. First of all, we are normally interested only in the middle body of the ship. Secondly, the smaller section reduces the amount of input data and computer time. And thirdly, the results may be accurate enough for the design purposes.

The magnitude of any error depends upon the load distribution, the geometry of the ship structure, and the portion of structure taken into consideration. The relationships between these parameters can be briefly described as follows:

The Load Distribution

For a structure consisting of a finite number of discrete elements, the external loads are shared by all the elements so that the equilibrium and compatibility conditions within and between the elements can be satisfied everywhere. The stiffer elements or the stiffer substructures will share more load than the weaker ones. In general, the shares of loads or the terminal forces for the elements are difficult to determine without a complete analysis of the whole structure. However, some special load distributions may be resolved with enough accuracy.

Consider a ship-like composite box girder with equally spaced and identical transverses (Figure H-1). If the self-balanced external load is uniform along the length, then all transverses share the same amount of load regardless of the stiffness of the longitudinals. In this case, the conventional two-dimensional analysis for one transverse will generate the same results as those from the three-dimensional analysis for the whole girder.

Suppose the load is not uniform but in some periodic pattern as indicated in Figure H-2. The sharing of the load will take place only among the members within several transverses.

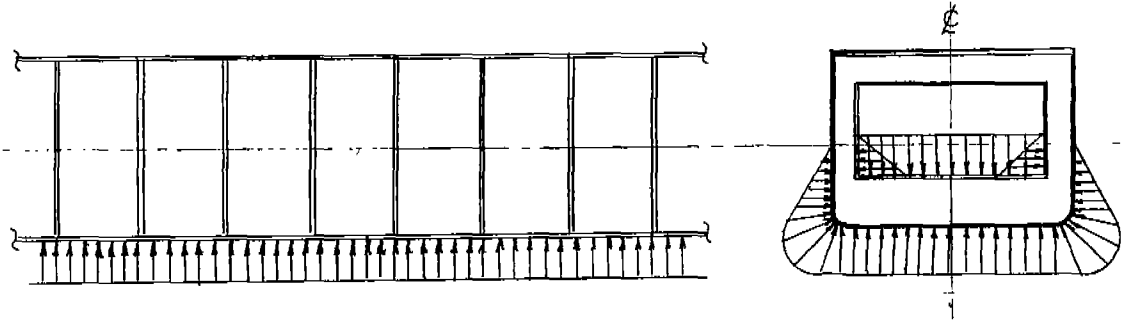

Figure H-1. Uniform Ship-Like Girder Subjected to Uniform Load

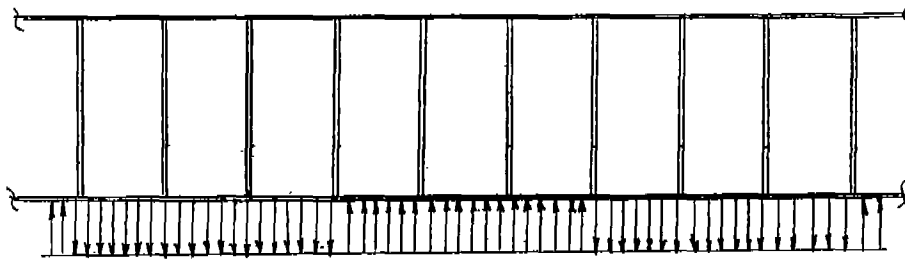

Figure H-2. Periodic Load

The Geometry of the Structure

If the transverses of the composite box girder are of proportional stiffness and if they are arranged in a regular pattern which corresponds to a similar pattern of the load distribution, an analysis may be confined to this portion of the hull with accurate results to be expected.

Although ships are usually designed with a definite pattern of transverses, the load distributions rarely follow accordingly. Hence, some error may likely evolve from a partial analysis. But in the light of a full-size analysis, where errors may be introduced in rounding off (a greater number of degrees of freedom) and/or in discretizing by a coarser mesh, the partial analysis may still be preferable.

The Error Involved in the Partial Analysis

As indicated in Chapter II, the rigid body movement of the transverses is the deflection of the ship hull and can be obtained by treating the ship hull as a grillage subjected to a set of line forces along the transverses. Let A_{ij}^Y be the influence coefficients of the prime longitudinals treated as a simple beam; then

$$V_{oi} = A_{ij}^Y Y_j \quad (H-1)$$

where Y_j is the difference of shear force at the location of the j^{th} transverse. Since the ship hull has the same length and the same fixities as the longitudinals, A_{ij}^Y are approximately equal to a_{ij}/F , where F is a scalar factor and a_{ij} is the basic influence coefficient. Considering the last term in equation (B-34) we have

$$a_{ij}^{-\beta y} V_{oj} \doteq \frac{t}{F} Y_i \quad (H-2)$$

where $\{\bar{a}_{ij}\} = \{a_{ij}\}^{-1}$

Similarly $a_{ij}^{-\beta} U_{oj} \doteq \frac{r}{G} X_i \quad (H-3)$

Note that the expression at the left of the equal sign does not involve the length of the portion of the ship nor the fixities of the longitudinals we want to analyze. Thus, if we treat this portion of the ship and all the longitudinals as simply a beam of this length with the same fixities, the first two terms of equation (B-34) and (B-33) are the same, and the third term is almost the same as these in the global analysis. The only significant difference between the global analysis and the partial analysis is the last term. Consider equation (B-31), this series represents the coupling effect of the deformation of the

scan
4704

transverses. In a global analysis, the coupling involves all transverses. In a partial analysis, this coupling involves only those transverses within this portion of the ship. For some load distributions the coupling does not involve all transverses; therefore, a partial analysis is as good as a global analysis. For example, the special case of identical transverses and uniform load yields all terms negligible except the first two in equation (B-33); thus, the full analysis reduces to the conventional two-dimensional analysis.

In general, the partial analysis as presented here has neglected the coupling effects of those excluded portions of the structure. The significance of these effects increases with the stiffness of the connecting elements (the longitudinals). The results from a partial analysis of the "JOHN A. MCCONE", which includes only holds no. 1,2,3,4, have provided good correlations with the experimental measurements.

APPENDIX I: STABILITY CHECKNomenclature

- t = thickness of the plate
 d = spacing of the vertical stiffness
 I_s = moment of inertia of the stiffeners
 E = modulus of elasticity
 b = depth of the web
 ν = Poisson's ratio
 σ_s = shear stress
 σ_b = bending stress
 σ_c = compressive stress
 F_S = factor of safety

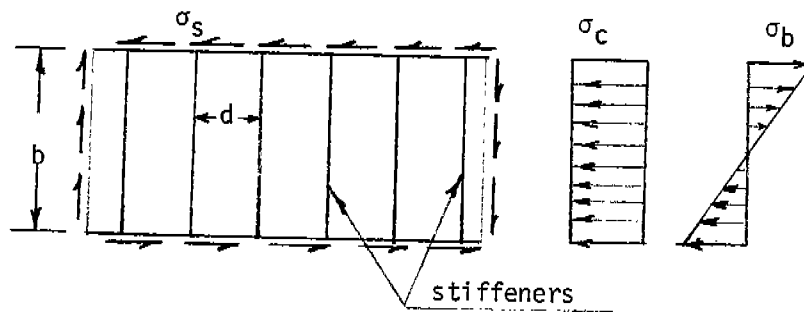

While the analytical methods developed in this report are based upon the assumption that the structure is everywhere stable, structural failures in large tankers often reveal the characteristics of shear buckling.

Numerous contributions have been published on the subject of stability of stiffened plates and webs of deep girders. Their Wah²³ has presented a very thorough review of the various methods, all of which are quite complicated and based upon assumptions that are not strictly valid for real structures, especially tankers. Fortunately for design purposes, though, these theories do provide a means for determining the upper bounds of the in-plane forces.

Criterion for Buckling Shear Loads

The following equations were interpolated from Stein and Fralich.²⁴

$$\sigma_{s,cr} = \frac{k_s E \pi^2 (t/b)^2}{12(1-\nu^2)} \quad (I-1)$$

$$\text{where } k_s = 5.3 + 5 (b/d)^2 g, \quad b/d \leq 5 \quad (I-2)$$

$$\text{and } g = \frac{2I_s (1-\nu^2)(b/d)^3}{t^3 d}, \quad b/d \leq 5 \quad (I-3)$$

Criterion for Buckling Bending Stress

Johnson and Noel²⁵ have provided the following critical bending stress for a simply supported plate.

$$\sigma_{b,cr} = 23.9 \frac{\pi^2 E (t/b)^2}{12(1-\nu^2)} \quad (I-4)$$

Criterion for Buckling Compressive Stress

$$\sigma_{c,cr} = \frac{4\pi^2 E (t/b)^2}{12(1-\mu^2)} \quad (I-5)$$

Criteria for Plate Buckling Under Shear Bending and Compressive Stresses

The following equation provides the upper bound limit for stability. Where this relationship exceeds unity, buckling is likely to occur.

$$\left(\frac{\sigma_s}{\sigma_{s,cr}}\right)^2 + \left(\frac{\sigma_b}{\sigma_{b,cr}}\right)^2 + \left(\frac{\sigma_c}{\sigma_{c,cr}}\right)^2 = 1/F_S, \quad (I-6)$$

Where F_S is a factor of safety.

Fortran IV Computer Program for Determining Buckling Stability

```

20 #IE FR5 STABLE,STABLE,STABLE
30 READ (5,100) E,G
40 101 FORMAT (/' THICKNESS WIDTH SHEAR COMPRESSIVE BENDING STRESS
50 1 SPACING AND MOMENT OF INERTIA OF STIFFENERS'//)
60 100 FORMAT ( )
70 102 FORMAT ( / ' THIS AREA NEEDS REINFORCEMENT' /)
80 103 FORMAT ( / ' THIS AREA IS STABLE UNDER THESE STRESSES ' /)
90 10 READ (5,100) T,B,S,SC,SB,XI,D
92 IF (T.LT.0.) GO TO 60
95 104 FORMAT (7E10.4)
100 WRITE (6,101)
110 WRITE (6,104) T,B,S,SC,SB,D,XI
120 Y=T/B
130 A=1.-G*G
140 A1=E*3.14159**2/12./A*Y*Y
150 IF (XI.EQ.0.) GO TO 20
160 X=B/D
170 GA=2.*XI*A/T**3/D
180 GO TO 30
190 20 GA=0.
200 30 SK=5.3+5.*X*X*GA
210 P=S/SK/A1
220 Q=SC/4./A1
230 R=SB/23.9/A1
240 C=P*P+Q*Q+R*R
250 IF (C.GT.1) GO TO 40
260 WRITE (6,103)
270 GO TO 10
280 40 WRITE (6,102)
290 P=SK*A1
300 Q=4.*A1
310 R=23.9*A1
325 WRITE (6,104) S,SC,SB
327 WRITE (6,105)
330 WRITE (6,104) P,Q,R
340 GO TO 10
345 105 FORMAT(/' THE CRITICAL SHEAR COM AND BENDING STRESSES ARE'//)
350 60 STOP
370 END

```

UNCLASSIFIED

Security Classification

DOCUMENT CONTROL DATA - R & D

(Security classification of title, body of abstract and indexing annotation must be entered when the overall report is classified)

1. ORIGINATING ACTIVITY (Corporate author) COM/CODE Corporation Alexandria, Virginia		2a. REPORT SECURITY CLASSIFICATION UNCLASSIFIED	
		2b. GROUP	
3. REPORT TITLE Structural Analysis of Longitudinally Framed Ships			
4. DESCRIPTIVE NOTES (Type of report and inclusive dates)			
5. AUTHOR(S) (First name, middle initial, last name) R. Nielson, P. Y. Chang, and L. C. Deschamps			
6. REPORT DATE July 1972		7a. TOTAL NO. OF PAGES 60	7b. NO. OF REFS 21
8a. CONTRACT OR GRANT NO. N00024-70-C-5219		9a. ORIGINATOR'S REPORT NUMBER(S)	
b. PROJECT NO.			
c.		9b. OTHER REPORT NO(S) (Any other numbers that may be assigned this report)	
d.		SSC-225	
10. DISTRIBUTION STATEMENT Unlimited			
11. SUPPLEMENTARY NOTES		12. SPONSORING MILITARY ACTIVITY Naval Ship Systems Command	
13. ABSTRACT <p>The technique of finite elements has brought about a new era to the field of structural analysis of ship structures. The application of this technique, however, is limited by the cost and capacity of the computer. Straight forward applications of the finite element method to the whole or to a major portion of the ship have so far been inaccurate and too expensive for design purposes.</p> <p>The method presented combines the advantages of the finite element technique and the uncoupling by coordinate transformation. A fine mesh may now be used to produce more accurate boundary conditions. The uncoupling transformations also reduce the computer time to about one-tenth of that by other methods. The critical assumptions and the basic theories have been verified with experimental test results from the tanker "JOHN A. MCCONE."</p>			

14 KEY WORDS	LINK A		LINK B		LINK C	
	ROLE	WT	ROLE	WT	ROLE	WT

SHIP RESEARCH COMMITTEE
Maritime Transportation Research Board
National Academy of Sciences-National Research Council

The Ship Research Committee has technical cognizance of the inter-agency Ship Structure Committee's research program:

PROF. R. A. YAGLE, Chairman, *Prof. of Naval Architecture, University of Michigan*
DR. H. N. ABRAMSON, *Director, Dept. of Mech. Sciences, Southwest Research Institute*
MR. W. H. BUCKLEY, *Coordinator of Hydrofoil Struc. Res., Naval Ship R & D Center*
MR. E. L. CRISCUOLO, *Senior Nondestructive Testing Spec., Naval Ordnance Lab.*
DR. W. D. DOTY, *Research Consultant, U. S. Steel Corporation*
PROF. J. E. GOLDBERG, *School of Civil Engineering, Purdue University*
PROF. W. J. HALL, *Prof. of Civil Engineering, University of Illinois*
MR. J. E. HERZ, *Chief Structural Design Engineer, Sun Shipbuilding & Dry Dock Co.*
MR. G. E. KAMPSCHAEFER, JR., *Manager, Application Engineering, ARMCO Steel Corp.*
MR. R. C. STRASSER, *Dir. of Research, Newport News Shipbuilding & Dry Dock Co.*
CAPT R. M. WHITE, USCG, *Chief, Applied Engineering Section, U. S. Coast Guard Academy*
MR. R. W. RUMKE, *Executive Secretary, Ship Research Committee*

Advisory Group II, "Ship Structural Design" prepared the project prospectus and evaluated the proposals for this project.

MR. J. E. HERZ, Chairman, *Chief Structural Des. Engr., Sun Shipbuilding & Dry Dock Co.*
MR. C. M. COX, *Asst. Naval Architect, Newport News Shipbuilding & Dry Dock Co.*
MR. C. R. CUSHING, *President, C. R. Cushing and Co.*
PROF. J. E. GOLDBERG, *School of Civil Engineering, Purdue University*
PROF. J. R. PAULLING, JR., *Chairman of Dept. of Naval Arch., Univ. of California*
MR. D. P. ROSEMAN, *Naval Architect, Hydronautics, Inc.*
CAPT R. M. WHITE, USCG, *Chief, Applied Engineering Section, U. S. Coast Guard Academy*

The SR-196 Project Advisory Committee provided the liaison technical guidance, and reviewed the project reports with the investigator.

MR. J. E. HERZ, Chairman, *Chief Structural Des. Engr., Sun Shipbuilding & Dry Dock Company*
MR. R. G. KLINE, *Associate Research Consultant, U. S. Steel Corporation*
PROF. J. R. PAULLING, JR., *Chairman of Dept. of Naval Arch., Univ. of California*

SHIP STRUCTURE COMMITTEE PUBLICATIONS

These documents are distributed by the National Technical Information Service, Springfield, Va. 22151. These documents have been announced in the Clearinghouse Journal U.S. Government Research & Development Reports (USGRDR) under the indicated AD numbers.

- SSC-213, *A Guide for Ultrasonic Testing and Evaluation of Weld Flaws* by R. A. Youshaw. 1970. AD 713202.
- SSC-214, *Ship Response Instrumentation Aboard the Container Vessel "S. S. Boston": Results from Two Operational Seasons in North Atlantic Service* by J. Q. Cragin. 1970. AD 712187.
- SSC-215, *A Guide for the Synthesis of Ship Structures Part One - The Midship Hold of a Transversely-Framed Dry Cargo Ship* by Manley St. Denis. 1970. AD 717357.
- SSC-216, *Program "Tranship" - A Computer Program for the Design of the Midship Section of a Transversely-Framed Dry Cargo Ship - Part Two* by Manley St. Denis. 1972.
- SSC-217, *Compressive Strength of Ship Hull Girders - Part I - Unstiffened Plates* by H. Becker, R. Goldman, and J. Pozerycki. 1971. AD 717590.
- SSC-218, *Design Considerations for Aluminum Hull Structures: Study of Aluminum Bulk Carrier* by C. J. Altenburg and R. J. Scott. 1971. AD 729021.
- SSC-219, *Crack Propagation and Arrest in Ship and Other Steels* by G. T. Hahn, R. G. Hoagland, P. N. Mincer, A. R. Rosenfield, and M. Sarrate. 1971.
- SSC-220, *A Limited Survey of Ship Structural Damage* by S. Hawkins, G. H. Levine, and R. Taggart. 1971.
- SSC-221, *Response of the Delta Test to Specimen Variables* by L. J. McGeady. 1971.
- SSC-222, *Catamarans - Technological Limits to Size and Appraisal of Structural Design Information and Procedures* by N. M. Maniar and W. P. Chiang. 1971.
- SSC-223, *Compressive Strength of Ship Hull Girders - Part II - Stiffened Plates* by H. Becker, A. Colao, R. Goldman, and J. Pozerycki. 1971.
- SSC-224, *Feasibility Study of Glass Reinforced Plastic Cargo Ship* by R. J. Scott and J. H. Sommella. 1971.