

SSC-270

**GROSS PANEL STRENGTH
UNDER COMBINED LOADING**

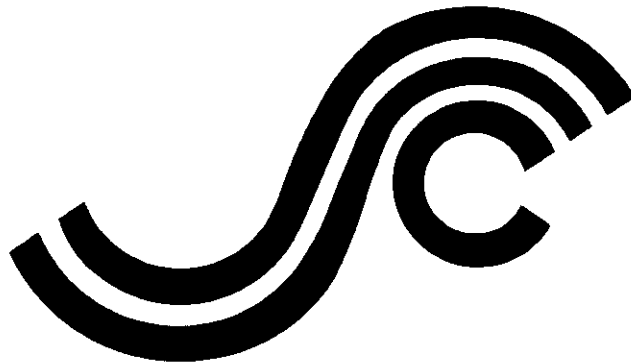

This document has been approved
for public release and sale; its
distribution is unlimited.

**SHIP STRUCTURE COMMITTEE
1977**

SHIP STRUCTURE COMMITTEE

AN INTERAGENCY ADVISORY
COMMITTEE DEDICATED TO IMPROVING
THE STRUCTURE OF SHIPS

MEMBER AGENCIES:

United States Coast Guard
Naval Sea Systems Command
Military Sealift Command
Maritime Administration
American Bureau of Shipping

ADDRESS CORRESPONDENCE TO

Secretary
Ship Structure Committee
U.S. Coast Guard Headquarters
Washington, D.C. 20590
SR-225

1 DEC 1977

Knowledge of the ultimate strength of ships is important, particularly in determining the appropriate margins of safety or the probable risk of failure under the loads acting on the vessel. The behavior of panels and grillages when subjected only to lateral loads is understood sufficiently well as to allow reasonable predictions to be made concerning their strength. However, the same has not been true with compressive loads, much less with combined compressive and lateral or normal loads.

By overdesign of these ship components the uncertainty can be reduced to an acceptably conservative level. An interest in optimization and energy conservation prompted the Ship Structure Committee to undertake a study project that would review all data on the strength of welded steel cross-stiffened plating under various loading conditions and then develop analytical procedures for predicting such strength, implementing more cost effective margins of safety.

This report contains the results of that study. Comments on this report, or suggestions for other projects in the ship structure area, will be welcomed.

Sincerely,



W. M. BENKERT
Rear Admiral, U.S. Coast Guard
Chairman, Ship Structure Committee

SSC-270

Final Report

on

Project SR-225, "Gross Panel Strength Study"

GROSS PANEL STRENGTH UNDER COMBINED LOADING

by

Alaa E. Mansour

Mansour Engineering, Inc.
Berkeley, California

under

Department of the Navy
Naval Ship Engineering Center
Contract No. N00024-75-C-4015

*This document has been approved for public release
and sale; its distribution is unlimited.*

U.S. Coast Guard Headquarters
Washington, D.C.

1977

ABSTRACT

The existing methods of predicting the behavior and ultimate strength of ship gross panels were evaluated, examined and in some instances, further developed. The assumptions, approximations, and deficiencies in each method were identified with the objective of determining the range of validity of each. The methods were classified in five broad categories with respect to their theoretical bases. Comparisons and correlations were conducted between the results of the different methods when applied to identical gross panels under biaxial edge compression and lateral pressure. Based on the identification of the assumptions and approximations in each method, and on the conducted comparisons and correlations, some expressions and procedures were selected, discussed, and extended. Lack of adequate procedures in certain areas were pointed out particularly when the collapse loads and mechanisms involve coupling between several modes of failure, and a biaxial loading condition exists in combination with lateral pressure. In some instances no clear measure of the relative reliability of the different procedures can be ascertained and a firm evidence of the "exact" solution is not available. A two-phase test program was recommended with immediate objectives and final goals outlined. An extensive bibliography is appended to this report.

TABLE OF CONTENTS

	<u>Page</u>
1. INTRODUCTION AND OBJECTIVE	1
2. METHODS OF GROSS PANEL ANALYSES.	3
A. Orthotropic Plate Analysis	3
B. Energy and Plastic Methods of Analyses	6
C. Grillages and Intersecting Beams	8
D. Finite Element Method.	10
E. Beam-Column Analysis	11
3. COMPARISONS AND CORRELATIONS	12
A. Comparisons Between the Different Methods of Gross Panel Analysis	12
B. Comparison with Experiments.	21
4. RECOMMENDATIONS AND DISCUSSION	30
A. Expressions for Estimating the Critical Buckling Loads in Gross Panels	30
B. Methods of Evaluating the Gross Panel Behavior and its Ultimate Strength.	38
C. Test Program	44
5. GENERAL REMARKS.	47
ACKNOWLEDGEMENT	48
REFERENCES.	49
APPENDIX I - BIBLIOGRAPHY	54
APPENDIX II - CRITICAL BUCKLING LOADS AND THEIR APPLICATION TO SHIP GROSS PANELS UNDER BIAXIAL LOADING CONDITION.	65

NOMENCLATURE

- A = $A_W + A_F + A_P$ = total area
- A_F = flange area
- A_P = plate area
- A_S = effective shear area
- A_W = web section area
- a, b = plate dimensions
- a_j = coefficients
- B = dimension of a gross panel in the y-direction
- C = constant
- D = flexural rigidity of an isotropic plate
- D_{xy} = effective torsional rigidity
- D_x, D_y = flexural rigidity of a plate in the x- or y-direction, respectively
- E_t = tangent modulus of a material
- E_x, E_y = modulus of elasticity in the x- or y-directions, respectively
- E, ν = Young's modulus of elasticity and Poisson's ratio for an isotropic material
- F = Airy stress function

NOMENCLATURE (CONT'D)

- G = modulus of elasticity in shear
- h = plate thickness
- h_p = plate thickness without stiffeners
- h_x, h_y = equivalent thickness of the plate and stiffeners (diffused) in the x- or y-directions, respectively
- I_{px}, I_{py} = moments of inertia of the effective plating alone in the x- or y-directions, respectively, about the neutral axes of the entire section
- I_x, I_y = moments of inertia of the stiffeners with effective plating in the x- or y-directions, respectively
- J_x, J_y, J_{xy} = compliance coefficients
- $[K_f]$ = flexure stiffness matrix
- $[K_g]$ = geometric stiffness matrix
- k = parameter
- L = dimension of a gross panel in the x-direction
- LBP = length between perpendiculars
- M_{lc} = plastic moment of longitudinal stiffener at center
- M_{le} = plastic moment of longitudinal stiffener at ends
- $M_{plastic}$ = plastic moment
- M_{tc} = plastic moment of transverse stiffeners at center
- M_{te} = plastic moment of transverse stiffeners at ends

NOMENCLATURE (CONT'D)

- m' = number of transverse stiffeners in a gross panel
 \bar{m} = moment of area
 m, n = number of half waves in which a plate buckles in the x- or y-direction, respectively
 N_x^* = $\frac{\bar{N}_x L^2}{\pi^2 D_x}$ = non-dimensional inplane load in the x-direction
 \bar{N}_x, \bar{N}_y = average inplane edge loads per unit length in the x- and y-directions, respectively
 N_y^* = $\frac{\bar{N}_y B^2}{\pi^2 D_y}$ = non-dimensional inplane load in the y-direction
 n' = number of longitudinal stiffeners in a gross panel
 \bar{n} = squash load ratio
 n_r = empirical constant
 $P_{ultimate}$ = ultimate load
 $\{P\}$ = nodal forces
 p.s.i. = pounds per square inch
 Q^* = $\frac{\bar{q} B^4}{\pi^4 h D_y}$ = non-dimensional lateral load
 \bar{q} = uniform lateral load per unit area of plate
 R_c = interaction forces between longitudinal and transverse stiffeners

NOMENCLATURE (CONT'D)

- r_e = effective radius of gyration
- S = plastic modulus
- S' = modified plastic modulus due to inplane loads
- S_F, S_W, S_P = contribution of the flange, web and plate, respectively, to the plastic modulus
- S_x, S_y = spacing of stiffeners extending in the y- or x-directions, respectively
- t_w = web thickness
- t.s.i. = tons per square inch
- w = deflection surface of a plate
- $2c$ = effective width
- ϕ_j = coordinate functions
- $\epsilon_x, \epsilon_y, \gamma_{xy}$ = middle plane strains
- η = torsion coefficient
- ν = Poisson's ratio of an isotropic material
- ν_x, ν_y = Poisson's ratio of an orthotropic plate in the x- or y-directions, respectively
- ρ = virtual aspect ratio
- γ = coefficient
- $\sigma_e = \frac{\pi^2 D}{a^2 h}$

NOMENCLATURE (CONT'D)

σ_0 = base stress

$$\sigma_x^* = \frac{\pi^2 \sqrt{D_x D_y}}{h_x B^2}$$

σ_{xcr} = critical buckling load in the x-direction

$\sigma_x, \sigma_y, \tau_{xy}$ = middle plane stresses

$$\sigma_y^* = \frac{\pi^2 \sqrt{D_x D_y}}{h_y L^2}$$

σ_{yp} = yield stress of a material

σ_{ycr} = critical buckling load in the y-direction

σ_z = direct stress in the normal direction to a plate

$\{\Delta\}$ = nodal displacement

SHIP STRUCTURE COMMITTEE

The SHIP STRUCTURE COMMITTEE is constituted to prosecute a research program to improve the hull structures of ships by an extension of knowledge pertaining to design, materials and methods of fabrication.

RADM W. M. Benkert, USCG (Chairman)
Chief, Office of Merchant Marine Safety
U.S. Coast Guard Headquarters

Mr. P. M. Palermo
Asst. for Structures
Naval Ship Engineering Center
Naval Ship Systems Command

Mr. M. Pitkin
Asst. Administrator for
Commercial Development
Maritime Administration

Mr. John L. Foley
Vice President
American Bureau of Shipping

Mr. C. J. Whitestone
Engineer Officer
Military Sealift Command

SHIP STRUCTURE SUBCOMMITTEE

The SHIP STRUCTURE SUBCOMMITTEE acts for the Ship Structure Committee on technical matters by providing technical coordination for the determination of goals and objectives of the program, and by evaluating and interpreting the results in terms of ship structural design, construction and operation.

NAVAL SEA SYSTEMS COMMAND

Mr. R. Johnson - Member
Mr. J. B. O'Brien - Contract Administrator
Mr. C. Pohler - Member
Mr. G. Sorkin - Member

U.S. COAST GUARD

LCDR T. H. Robinson - Secretary
LCDR S. H. Davis - Member
CAPT C. B. Glass - Member
Mr. W. C. Dietz - Member

MARITIME ADMINISTRATION

Mr. F. Dashnaw - Member
Mr. N. Hammer - Member
Mr. R. K. Kiss - Member
Mr. F. Seibold - Member

MILITARY SEALIFT COMMAND

Mr. T. W. Chapman - Member
CDR J. L. Simmons - Member
Mr. A. B. Stavovy - Member
Mr. D. Stein - Member

AMERICAN BUREAU OF SHIPPING

Mr. S. G. Stiansen - Chairman
Dr. H. Y. Jan - Member
Mr. I. L. Stern - Member

NATIONAL ACADEMY OF SCIENCES SHIP RESEARCH COMMITTEE

Mr. O. H. Oakley - Liaison
Mr. R. W. Rumke - Liaison

SOCIETY OF NAVAL ARCHITECTS & MARINE ENGINEERS

Mr. A. B. Stavovy - Liaison

WELDING RESEARCH COUNCIL

Mr. K. H. Koopman - Liaison

INTERNATIONAL SHIP STRUCTURES CONGRESS

Prof. J. H. Evans - Liaison

U.S. COAST GUARD ACADEMY

CAPT W. C. Nolan - Liaison

STATE UNIV. OF N.Y. MARITIME COLLEGE

Dr. W. R. Porter - Liaison

AMERICAN IRON & STEEL INSTITUTE

Mr. R. H. Sterne - Liaison

U.S. NAVAL ACADEMY

Dr. R. Bhattacharyya - Liaison

U.S. MERCHANT MARINE ACADEMY

Dr. Chin-Bea Kim - Liaison

NOTES

1. INTRODUCTION AND OBJECTIVE

Shipbuilding history throughout the world has been, and still is, largely dependent on experience and empiricism. Requirements for the design of the structural elements in ships have been developed on the basis of empirical data and past "successful" designs. In some cases these data have been refined and confirmed by theoretical analysis, but in many cases no analytical procedures were available during the course of their development.

In the last decade, however, the demand for new and more efficient modes of marine transportation and for other ocean engineering activities has forced naval architects and civil engineers to search for general and reliable methods of analysis which would provide the necessary correlation between the sea loads acting on the structure and its dimensions. Recognition has been given to the fact that it is not sufficient to define a "successful" ship as one which has not failed (since it could be grossly over-designed), and that requirements based purely on experience might not always be safely extrapolated to new configurations and larger ship types. In short, the need exists more than ever to provide structural efficiency combined with safety in withstanding the sea loads.

The "basic structural element" or the "building block" in ships and many other marine structures consists of a plate reinforced with stiffeners. This plate-stiffener combination is usually subjected to loads normal to its own plane due to water pressure, cargo loads, deck loads, etc. In addition, inplane forces induced from the overall bending and twisting of the ship act at the boundaries of such stiffened gross panels. In general, the inplane forces can take the form of tensile, compressive, or shear loads, and some of them may occur simultaneously on all four boundaries of the gross panel. The panel itself can be stiffened in one or both directions, and the stiffeners extending in each direction are usually similar.

Beyond certain values, the inplane compressive and shear loads may cause instability of the gross panel which, together with the normal loads, will induce large deflections. Under such conditions, geometric non-linearities will be present and therefore, non-linear analysis has to be conducted in any analytical method used for the prediction of the behavior of the panel in the post-buckling range. Prior to failure of the panel, large deformations will also take place due to material non-linearities in the inelastic range; therefore, analytical procedures suitable for the prediction of the ultimate strength of the gross panel should take into account such material non-linearities. The gross panel may fail in one of several modes depending on the stiffeners' spacing, their geometric properties, the plate thickness, initial deformations, and the welding characteristics. Tripping of the stiffeners, local failure due to instability of the plate elements of the stiffeners, plate failure between the stiffeners and failure of the cross-stiffened panel as a whole are some possible modes of failure.

In general, plate buckling does not necessarily mean immediate failure since membrane stresses will develop as deflection becomes large and, together with bending stresses, will resist the external loads. Initial deformation and deflections due to welding, fabrication imperfections and presence of camber may have a rather distinct effect on the panel behavior when the inplane loads are in range of their critical values for buckling. Their effect, however, is less pronounced if these loads are much larger than the critical values.

It is difficult to determine the boundary conditions of the gross panel which describe exactly the conditions in the actual ship. Nevertheless, in order to predict analytically the behavior and the ultimate strength of the gross panel, specific information about the restraints of the support is useful. A wide variety of support conditions may exist in the actual ship. However, from possible symmetry or antisymmetry of the structural configuration or the loading, certain combinations of boundary conditions are more useful than others.

The objective of this study is to select, from existing methods, reliable analytical procedures for examining the behavior and predicting the ultimate strength of welded cross-stiffened panels under combined lateral and biaxial loads. The procedures should cover the wide range of parameters describing the geometric configurations and loading conditions encountered frequently in ship structures and should be capable of predicting the onset of non-linear behavior and the probable initial mode of failure. Recommendations are to be made as to the adequacy of the procedures and possible experimental programs for verifications are to be suggested.

2. METHODS OF GROSS PANEL ANALYSES

An important first step in the selection of appropriate methodology for the analysis of gross panel strength is to conduct a complete and up-to-date survey of the existing methods. It seems appropriate then to classify the available methods with respect to their theoretical basis, as for example, methods based on finite element technique, equivalent orthotropic plates, grillages and intersecting beam-columns, etc. The basic assumptions and approximations made in each of these methods are then clearly identified and examined. The range of validity of such assumptions are also evaluated in order to estimate bounds on the relevant design parameters beyond which such assumptions are invalid.

In the literature survey, two aspects were considered:

- a. Methods related to evaluating and examining the gross panel behavior under lateral and inplane loads including methods of estimating the critical buckling loads.
- b. Methods related to failure analysis and failure modes which may be used for predicting the ultimate strength of the gross panel.

Based on the conducted survey, the methods examined can be classified under five broad categories which, in some cases, may overlap. The five categories are: (a) orthotropic plate analysis, (b) energy and plastic methods of analyses, (c) grillages and intersecting beams, (d) finite element method, and (e) beam-column analysis. Each of these is discussed separately as follows.

A. Orthotropic Plate Analysis

In this method the actual plate stiffener combination is idealized by an equivalent orthotropic plate. The degree of approximation involved depends to a great extent on the number of stiffeners in each direction and the uniformity of the gross stiffened panel.

An orthotropic plate may be defined as a homogeneous plate whose elastic properties are different in the two orthogonal directions in the plane of the plate. The constitutive relations can be written in the form of:

$$\begin{Bmatrix} \sigma_x \\ \sigma_y \\ \tau_{xy} \end{Bmatrix} = \frac{1}{1 - \nu_x \nu_y} \begin{bmatrix} E_x & E_x \nu_y & 0 \\ E_y \nu_x & E_y & 0 \\ 0 & 0 & G(1 - \nu_x \nu_y) \end{bmatrix} \begin{Bmatrix} \epsilon_x \\ \epsilon_y \\ \gamma_{xy} \end{Bmatrix} \quad (1)$$

where

$$E_x \nu_y = E_y \nu_x$$

If the thickness of the rectangular orthotropic plate is small relative to its other dimensions ($a, b/h > 40$) so that both the normal stress σ_z and the effect of shear deflection can be disregarded, then the governing differential equations including the non-linear terms in the sense of von Kármán [1]* for the large deflection behavior of the plate are derived in reference [2] and are given by:

$$D_x \frac{\partial^4 w}{\partial x^4} + 2D_{xy} \frac{\partial^4 w}{\partial x^2 \partial y^2} + D_y \frac{\partial^4 w}{\partial y^4} = q(x, y) + \frac{\partial^2 F}{\partial y^2} \frac{\partial^2 w}{\partial x^2} + \frac{\partial^2 F}{\partial x^2} \frac{\partial^2 w}{\partial y^2} - 2 \frac{\partial^2 F}{\partial x \partial y} \frac{\partial^2 w}{\partial x \partial y}$$

$$J_x \frac{\partial^4 F}{\partial x^4} + 2J_{xy} \frac{\partial^4 F}{\partial x^2 \partial y^2} + J_y \frac{\partial^4 F}{\partial y^4} = \left(\frac{\partial^2 w}{\partial x \partial y} \right)^2 - \frac{\partial^2 w}{\partial x^2} \frac{\partial^2 w}{\partial y^2} \quad (2)$$

where w is the deflection function; F is the Airy's stress function; D_x , D_y and D_{xy} are rigidity coefficients; and J_x , J_y and J_{xy} are compliance coefficients given by:

$$D_x = \frac{E_x h^3}{12(1-\nu_x \nu_y)} ; D_y = \frac{E_y h^3}{12(1-\nu_x \nu_y)} ; 2D_{xy} = \frac{4Gh^3}{12} + \nu_x D_y + \nu_y D_x$$

$$J_x = \frac{1}{E_y h} ; J_y = \frac{1}{E_x h} ; 2J_{xy} = \frac{1}{Gh} - \nu_x J_y - \nu_y J_x \quad (3)$$

Equations similar to the above have been derived in reference [3] for the case of orthotropic plates with small initial deflection. The two fourth-order partial-differential equations (2) describe the behavior of the plate in the post-buckling range as well as in the pre-buckling range. Equations (2) reduce to von Kármán's fundamental equations [1] for large deflection of isotropic plates when $E_x = E_y = E$, and $\nu_x = \nu_y = \nu$ are substituted in the expressions of the coefficients D_x , D_y , D_{xy} , J_x , J_y , and J_{xy} .

The two partial differential equations (2) require a total of sixteen boundary conditions, eight of these are specified conditions of either edge loads or edge displacements, the other eight specify the support conditions.

Sometimes, the exact solutions for the boundary value problem are hard to obtain. Several approximate methods can be applied, such as Galerkin's method and the finite difference method. In the Galerkin method, one considers the governing differential equation of the form:

$$L(w) = C \quad \text{in } R \quad (4)$$

*Numbers in brackets designate references at the end of the report.

Assuming w can be expressed in the approximate form:

$$\bar{w} = \sum_i^n a_i \phi_i(x,y) \quad i = 1 \dots n \quad (5)$$

then from the weighted residual concept, the following condition must be satisfied:

$$\int_R (L(\bar{w}) - C) \phi_i dR = 0 \quad i = 1 \dots n \quad (6)$$

This leads to a total of n simultaneous equations to be solved for the n unknowns a_i .

The Galerkin method is in principle equivalent to the Ritz method which is based on the calculus of variation. But indeed, in the Galerkin formulation no reference is made to variational problems. Moreover, the Galerkin method can be applied to a broad class of problems phrased in terms of integral equations.

The Galerkin method as well as the method of variation for approximation of boundary value problems consider analytical expressions for the approximation functions. When the boundary values are not easily given by simple analytical expression, it is difficult to make a choice of the coordinate functions $\phi_i(x,y)$. In this case, the finite difference method can be applied. The finite difference method gives numerical values for unknown functions at a set of discrete points instead of the analytical expression defined over the whole region. It reduces the given analytical boundary-value problem to a problem of difference equations. Usually this method leads to consideration of a system of large numbers of algebraic equations in many unknowns.

In reference [2], equations (2) are solved under two sets of support conditions: (a) all edges clamped, and (b) two edges simply supported and other edges clamped. The behavior of the orthotropic plate is examined and distributions of deflection, membrane stress, bending moments, etc., along the plate centerlines are presented (no initial deflection). In reference [3] non-dimensional design curves of the center deflection, the critical load, the effective width, and the bending moment are presented for different values of uniaxial compressive load, lateral load, initial deflection, and the virtual aspect ratio of the plate. Some examples of the use of the design curves are given in which the results are compared for different initial deflections and boundary conditions. In both references [2] and [3] geometric non-linearities are considered in the problem formulation and thus the results are suitable for investigating the plate behavior in the post-buckling range.

Other design curves based on orthotropic plate analysis were introduced in the original work of Schade [4,5]. In these references the deflection was assumed small compared to the plate thickness ($w_{\max}/h \leq 0.5$) and the design charts presented are suitable for examining the plate behavior in the pre-buckling range. Schultz [6] examined the stability problem of orthotropic plates and presented design charts for the calculation of the critical loads. In reference [7], additional design charts are given for plates under lateral and uniaxial inplane

loads within the scope of the linearized (second order) theory. The buckling loads are also given for four different sets of boundary conditions. Smith and Faulkner [8], Roren and Hansen [9], Soper [10], Ames [11], Ando [12] among others [13,14,15] used the orthotropic plate theory for the analysis of ship stiffened plates.

In particular, orthotropic plates subjected to lateral load and biaxial edge compression and edge shear have been examined in references [13] and [14]. In these references some non-dimensional design charts are presented giving the center deflection, critical buckling load, effective width, and bending moment in the stiffened plating. Some examples of application illustrating the use of the charts are also presented.

In the application of the orthotropic plate theory, the rigidity and compliance coefficients* are conceived as applying to a homogeneous orthotropic plate of constant thickness which is equivalent to the actual plate-stiffener combination. The term equivalent requires careful definition, since the orthotropic plate obviously cannot be equivalent to the actual stiffened plate in every respect. The stiffeners in either direction are assumed to be equally stiff and equally spaced, with spacing small enough that the structure may be considered quite fully effective. So the validity of representing the gross panel by an equivalent orthotropic plate depends to a great extent on the number of stiffeners in each direction, their spacing, and how identical they are as far as their stiffness characteristics are concerned. Such an approximation becomes critical when the number of stiffeners is small.

From experiments conducted at Stanford University [16] the authors indicated that, orthotropic plate theory and experiments have shown a different degree of correlation depending on the boundary conditions and type of stiffeners used. The correlation varies between good for the case of a plate simply supported all around to less satisfactory for the case of a plate fixed all around. It is also found that, under any specific case of boundary condition, the correlation with theory is better when the number of stiffeners in each direction is increased.

Additional comparisons were made by C. Smith in reference [15]. The results showed that for uniform simply supported grillages, the orthotropic plate solution gives very accurate results even when gross panels have as few as three longitudinal and three transverse beams. For other boundary conditions, the orthotropic plate analysis gave less accurate results. See ref. [15] for details on the manner of loading.

On the basis of these comparisons [15,16], it appears that the application of the orthotropic plate theory to ship gross panels should be restricted to stiffened plates with more than three stiffeners in each direction. In addition, stiffeners in each direction should be similar, i.e., uniform gross panel.

B. Energy and Plastic Methods of Analyses

Exact solution of the governing differential equations of stiffened plates often presents a difficult analytical problem and can be solved in closed form only in some special cases. The introduction of the concept of strain energy allowed for considerable development of structural analysis methods. One formulation of the strain energy is the standard type of variational principle which constitutes a very powerful approach to numerical methods such as the finite element method.

*See Section 3 and reference [14] for the definition and the approximate determination of the rigidity and compliance coefficients.

Widely used methods such as principles of virtual forces and displacements, minimum potential energy, limit analysis, and shake-down analysis may be also classified under energy methods.

In the method of stationary potential energy, the stiffeners and the plate are forced to deflect together and the final deflection shape is such that the total potential energy of the system is minimal. The final deflection shape is assumed to be in the form of a series with finite numbers of terms for approximation:

$$w(x,y) = a_1 f_1(x,y) + a_2 f_2(x,y) + \dots \quad (7)$$

where the functions f_1, f_2, \dots are the bases of the function $w(x,y)$ and the coefficients a_1, a_2, \dots are the generalized coordinates. Using the minimum potential energy principle, a set of simultaneous equations are obtained with the coefficients a_i as unknowns. When the determinant of this simultaneous equation is put equal to zero, an equation for determining the critical loading for instability problems will be obtained. For large deflection problems, these equations are non-linear in the parameters a_i and numerical methods may be used in the solution.

This type of analysis becomes cumbersome if the plate is stiffened with a large number of stiffeners. The deflection function can be chosen only for some special cases. For these reasons, this method seems not to be often chosen directly to solve practical problems. But the concept of this method is very important in application to the numerical methods such as in the formulation of element stiffnesses used in the finite element method.

As mentioned earlier, the energy methods can also provide a powerful tool in the orthotropic plate solutions. For example, in reference [17] the energy method, together with Lagrangian multipliers, is used to solve the stability problems of orthotropic plates under various boundary conditions. The theoretical results presented compared favorably with those from tests and literature.

In the limit analysis, the gross panel can be idealized as a framework of beams which are made of material with an elastic-perfectly plastic moment-curvature relation. Small strains are usually assumed and the applied loads are assumed to be proportional, i.e., all loads are increased gradually to their final values in constant ratio. On these bases, lower and upper bound theorems of the plastic limit load or the "collapse" load were advanced by Drucker, Greenberg, and Prager in references [18,19]. The upper bound theorem simply states that the structure will collapse if there is any compatible pattern of plastic deformation for which the rate at which the external forces do work exceeds the rate of internal dissipation. This theorem, which gives the "unsafe" values of the collapse load postulates that if a compatible path of failure exists, the structure will collapse. The lower bound theorem states that, if an equilibrium distribution of stress can be formed which balances the applied load and is everywhere below yield or at yield, the structure will not collapse or will be just at the point of collapse. This theorem, which gives the "safe" values or the conservative limit of the collapse load, reaffirms that the material will adjust itself to carry the applied load when possible. The limit load itself is the minimum upper bound or the maximum lower bound. The exact limit load, however, can be rarely determined for complex gross panels and thus, the lower and upper bound theorems provide a valuable means to bracket its value.

In the limit analysis, the loads acting on a structure are not permitted to change their direction or ratio of their magnitudes. These conditions are not satisfied in an actual ship structure where loads are in general cyclic and random in nature. A suitable means for estimating the limit load under their repeated loading condition is the use of shakedown analysis. A safe limit to use may be one at which the progressive or alternating plastic deformation is limited and the response of the material becomes essentially elastic, i.e., the shakedown load. If the structure does not shakedown, plastic flow will continue to take place during each cycle of load application leading eventually to failure. The shakedown analysis, however, does not provide any information on the number of load cycles required for the structure to reach a shakedown state.

Bleich, H. [20], Symonds and Prager [21], and Koiter [22] developed and advanced a lower and upper bound theorem of the shakedown load. It was indicated that, if shakedown is not reached failure can be either through "incremental collapse" where a definite amount of plastic deformation recurs always in the same direction or "alternating plasticity" where plastic flow occurs at certain sections alternately in the opposite directions.

The application of limit and shakedown analyses to ship gross panels and structures has been rather limited. In reference [23] elastic and plastic limit analyses of a web frame of a tanker are presented and the collapse mechanisms and the corresponding collapse pressures are estimated. In reference [24] limit and shakedown analyses are presented for some ship frames and grillages. Additional application and correlation with experiments for stiffened plates and grillages under lateral load only are given in [25] and [26].

C. Grillages and Intersecting Beams

In this category the gross stiffened panel is treated as a system of discrete intersecting beams (plane frame) with loads perpendicular and in the plane of the grillage. Each beam is assumed to consist of the stiffener plus a portion of the plate over which the stress can be assumed uniform with a value equal to the maximum value, i.e., the effective breadth. The torsional rigidity of the plate and Poisson's ratio effects on the overall behavior of the gross panel are thus ignored in this type of analysis. The model, however, allows for different stiffener sizes and spacings within each set of parallel stiffeners. Although in ship gross panels the stiffener spacings are usually equal, the allowance for different stiffener sizes is undoubtedly desirable. The model also imposes no restrictions on the number of stiffeners in each direction or any irregularities in the boundaries.

The validity of representing the gross panel by a grillage (plane frame) becomes particularly critical when the flexural rigidities of the stiffeners are small in comparison with the plate stiffness. However, for ratios of the stiffener's rigidity per unit width to the plate stiffness larger than about 60, i.e., $EI/bD > 60$, this grillage approximation seems to be suitable.

In the general method of grillage analysis, a set of governing differential equations can be formulated for all the discrete stiffeners using beam theory. The set can be solved under the appropriate consistent conditions at the intersection points and the boundary conditions. Usually, in ship grillages, it is assumed that

the external lateral loads act on the transverse stiffeners and the longitudinal stiffeners are acted upon by the forces (reactions) at the intersection points in order to simplify the problem. A large system of simultaneous algebraic equations will result and, for all but the smallest grillages, this type of analysis requires the use of digital computers if the general method of analysis is used [15].

Several simplified methods have been introduced to reduce the amount of computation involved in the elastic analysis of grillages [27, 28, 29, 30]. In references [27] and [28] certain matrix transformations were used to uncouple the deflection equations thus considerably simplifying the computation. In reference [29] the stability problem and critical loads of rectangular grillages whose edges are elastically restrained against rotation have been treated. A method for treating some inelastic effects is also presented which is based on a plasticity reduction factor incorporated only in the x-direction according to Faulkner [31]. Plots of selected coefficients are given to allow the use of the method in manual analysis. In reference [30] explicit formulas and tables are presented for the edge moments and interaction forces which allow for analyzing the beam elements of a grillage under lateral load only using simple beam theory.

Faulkner in reference [31] used the discrete beam equations to determine the buckling stresses for biaxially compressed grillages having opposite boundaries equally elastically constrained against rotation. He extended the solution to the more general case where the opposite edges are unequally restrained through certain approximations. The reference also includes a discussion of the inelastic effects in flat yield material and a suggested treatment for strain hardening. In references [32] and [33] approximate formulations for the compressive strength of welded grillages is presented with emphasis given to the effect of residual welding stresses on strength. Both uniaxial and biaxial compression are considered.

Kondo [34] and Rutledge and Ostapenko [35] presented a grillage analysis in which the transverse stiffeners were assumed to be infinitely rigid. The portion between two adjacent transverses is then analyzed as longitudinally stiffened panels. The ultimate strength was then computed for such panels under lateral and uniaxial loads. In reference [36] Parsanejad and Ostapenko extended this type of analysis and the transverse stiffeners each with an assumed effective plate portion are treated according to small deflection elastic-plastic beam theory. The longitudinally stiffened panel is treated as a series of beam-columns each consisting of a plate of width equal to the spacing of the longitudinal stiffeners and the longitudinal stiffener itself. Each longitudinal beam is then assumed to act as if it were a part of longitudinally stiffened panel with an infinite number of identical stiffeners. The effect of residual stresses is included assuming that their distribution does not vary along the length. Stresses produced by bending of the plate between stiffeners are considered to have a negligible effect on the inplane plate behavior and the average stress in the plate (small b/h) remains constant in the post-buckling range and equal to the buckling stress. The plate components of the stiffeners are so proportioned that the ultimate strength of the grillage is reached before local buckling takes place. The ultimate capacity is determined by incrementing the loads using a computer program to solve the resulting non-linear simultaneous equations. Comparison of the method with some available test results is presented in the report. The limitations imposed by some of the many assumptions made in these analyses can be restricting particularly in the post-buckling range.

D. Finite Element Method

Here the gross-panel behavior is simulated by approximating it with that of a model composed of elements in which the displacement field is restricted to preselected displacement patterns or "shape functions". The general deformation of the model is then specified by the magnitudes of the generalized coordinates associated with the shape function. The general deformation can be determined by the energy method or Galerkin method, and is then interpreted as an approximation to the general deformation of the gross panel. The degree of approximation involved in this type of analysis to represent the conditions in the gross panel depends primarily on the set of shape functions selected and the compatibility conditions imposed along the boundaries of the elements. It also depends on the accuracy of the numerical computation.

Application of the principle of minimum potential energy to the approximating structure results in a reduction of the problem to one of solving a set of simultaneous equations relating nodal forces and displacements. The general equilibrium equation for the approximating structure can be expressed in the form:

$$[K_f] \{\Delta\} + \lambda[K_g] \{\Delta\} = \{P\} \quad (8)$$

where $\{\Delta\}$ and $\{P\}$ are the displacements and applied loads at the nodes. $[K_f]$ is the conventional flexure stiffness matrix, $[K_g]$ is the geometric stiffness matrix which is solely dependent on geometric parameters and introduces the parameters which model the stability problem. Letting $\{P\} = 0$ and $|[K_f] + \lambda[K_g]| = 0$, one can determine the eigenvalues λ and the associated buckling modes $\{\Delta\}$. Usually a great number of degrees of freedom will be involved in the eigenvalue problem, therefore careful consideration must be given to the method of solution. If geometric non-linearities are present (e.g., large deflections) higher order terms of the derivatives of the displacements are considered in formulating the stiffness matrices. The incremental model can be used which is based upon the treatment of the loading as a sequence of steps with linearization of the analysis within each step. In the plastic range, either the incremental theory or the total strain theory of plasticity can be applied to obtain the stiffness matrices. Generally, the von Mises yield criterion is upheld and maintained. Also, iterative and step-by-step procedures for solution of the complete system is required.

In representing the gross panel by the finite element technique, two discretized models can be generated. The gross panel can be either represented by (1) bending and stretching plate elements together with beam elements modeling the stiffeners, or (2) orthotropic plate elements which reflect the difference in gross panel properties in the perpendicular directions. In general, the finite element method is well established for predicting the behavior of the gross panel in the linear elastic range and for the linear stability analysis for determining the buckling loads and the corresponding mode shapes. It is, however, less developed for the plastic-buckling analysis and the determination of the collapse loads and local instability.

It is not the intention to give a complete survey of the development and application of the finite element method in this report as the number of publications in this area is enormous. An excellent source for such development survey is presented in reference [37]. However, a few papers which have direct relevance to this work will be briefly discussed.

Probably the first paper in the naval architecture field in which the finite element analysis is used in ship structure is due to Paulling [38]. Since then, the number of publications has been increasing very rapidly and classification societies (e.g., ABS [39]) use for such a technique has been also growing steadily.

Recently, the treatment of instability and non-linear problems (geometric and material non-linearities) has drawn considerable interest [40, 41, 42, 43]. In reference [40] Kavlie and Clough developed a program for the analysis of stiffened plates under combined inplane and lateral loads. A computer program listing is given and a few examples of bending and buckling of stiffened plates are presented. In reference [41] a finite element method for the plastic buckling of unstiffened plates is presented. Terazawa, et al., advanced a finite element method [42] for the elastic-plastic buckling of plates with stiffeners. The material is assumed to be elastic-perfectly plastic and the moment curvature relationship is obtained in the plastic region using the incremental theory and the total strain theory of plasticity.* In reference [43] an efficient computational procedure for the finite element elastic-plastic analysis was developed. The model is based on separating the elastic parts of the structure and eliminating it from the non-linear solution process, thus reducing the computation time. Additional recent advances in the use of finite element methods for predicting the ultimate collapse behavior is given in references [44] and [45].

E. Beam-Column Analysis

In this method a single "beam" of the gross panel consisting of a single stiffener and the effective breadth of plating is analyzed. The beam is considered to be subjected to lateral line load and axial load. The torsional rigidity of the gross panel, the Poisson's ratio effect and the effect of the intersecting beams are all neglected in this type of analysis. The latter effect is, sometimes, incorporated in the analysis by locating springs at the intersection points. This method of analysis is popular among designers because it is relatively simple and less time consuming. The degree of accuracy, however, becomes critical particularly in the presence of biaxial loading conditions and when the plate stiffness is relatively large compared to the stiffener's rigidity.

A bibliography which emanated from the evaluation, classification, and examination of methods of gross panel analyses is given in Appendix I. The bibliography is classified, more or less, in a manner similar to the methods discussed with additional "general" and "experiments" sections. Another bibliography for the ultimate load of box structures and primary and secondary structures has been compiled and evaluated by Stavovy [46].

Upon the completion of the detailed evaluation and classification of the method of gross panel analysis it was apparent that no single method or a general theory exists that is always superior for all gross panels of different proportions (plate and stiffeners), loading conditions, extent of deformation (large, small), and which can predict exactly the lowest failure mode under a wide variety of load combinations. This immediately pointed towards the significance of the broadly based method of evaluation and its importance in the final recommendations.

*The moment curvature relations in reference [42] were based on the relations between stress increments and strain increments as furnished by the incremental theory of plasticity, and also, on the stress-strain relations as given by the total strain theory of plasticity for comparison.

3. COMPARISONS AND CORRELATIONS

A. Comparisons Between the Different Methods of Gross Panel Analysis

Several methods among those evaluated in Section 2 of this report were applied to the same gross panel configuration and loading condition in order to assess their results comparatively. A general loading which consists of biaxial compressive inplane loads in the x- and y-directions and lateral pressure is considered to act on the stiffened panel. Due to the limitation of the two finite element programs used (STRUDL and SOLID SAP), only the behavior in the linear range (pre-buckling) was examined. The non-linear behavior of the panel can be predicted, however, from the charts presented in [14]. Additional comparisons using plastic limit analysis are given in sub-section B.

The methods used to predict the behavior of the panel under the described loads are:

- (1) Orthotropic Plate Analysis. Two types of analyses were conducted.
 - (a) First Order Analysis*
 - (b) Second Order Analysis**
- (2) Finite Element Analysis using ICES-STRUDL II [47] program (Integrated Civil Engineering System--Structural Design Language)
- (3) Finite Element Analysis using "SOLID SAP" [48] program. Two types of analyses were conducted.
 - (a) The gross panel discretized using beam elements to simulate stiffeners and plate elements to simulate the plate behavior.
 - (b) The gross panel discretized using orthotropic plate elements.
- (4) Grillage analysis of a system of discrete intersecting beams.
- (5) Beam-column analysis using beam theory.

The gross panel considered is shown in Figure 1 with dimensions and number of stiffeners indicated. The panel is simply supported at the two long edges and fixed at the other edges. The stiffener's dimensions and properties are shown in Figures 2 and 3 for the long and short stiffeners respectively. The material is assumed to be steel with $E = 30 \times 10^6$ p.s.i. and $\nu = 0.3$. The effective breadth of plating, the neutral axes, moments of inertia, section moduli, etc., were computed for the stiffeners in each direction and used in determining the rigidity coefficients for the orthotropic plate analyses and the grillage analysis.

For the orthotropic plate analyses, the design charts presented in reference [14] were used. Several parameters had to be computed for approximating the

*The inplane and bending loads are assumed to be decoupled.

**The effect of the inplane loads on deflection and bending stress is included.

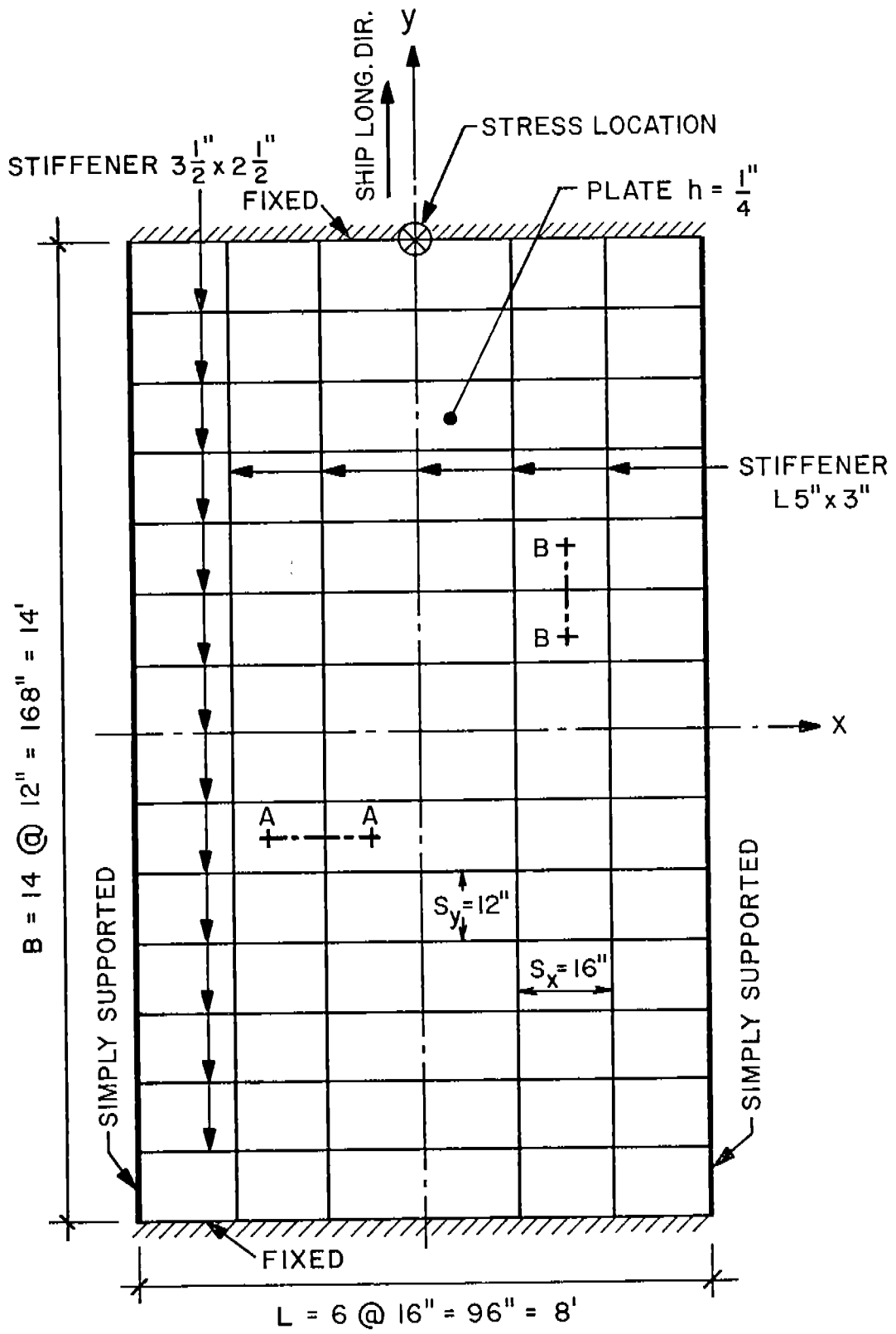

FIG.1 GROSS PANEL DIMENSIONS

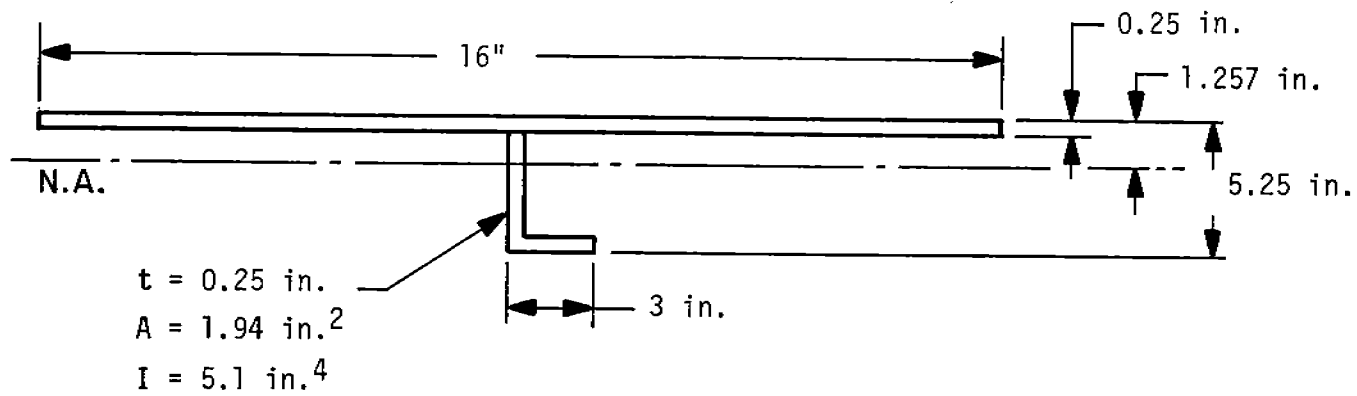

FIGURE 2 - SECTION A-A

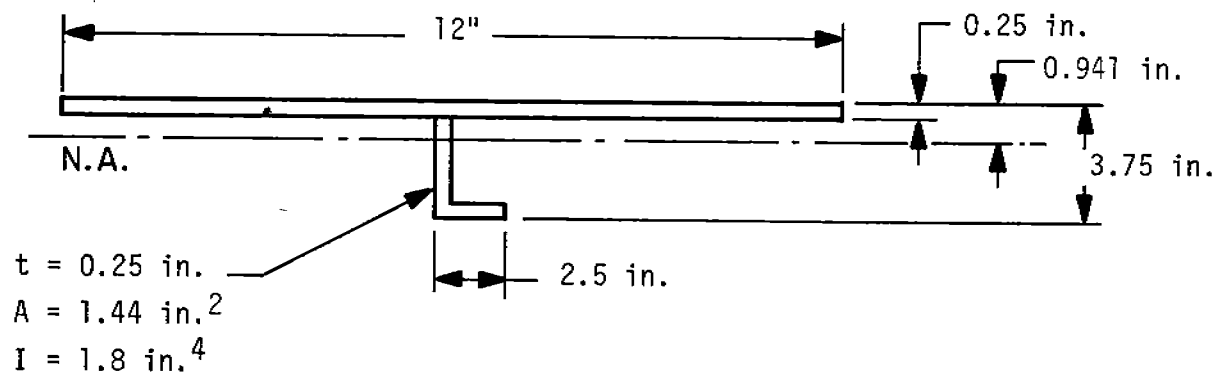

FIGURE 3 - SECTION B-B

stiffened plate by an equivalent* orthotropic plate. All nomenclature used here to represent the coefficients of the stiffened plate and the equivalent orthotropic plate are the same as in [14] (see also the list of nomenclature). A summary of the computational results are given in the following. (See reference [14]).

$$D_x = \frac{E I_x}{S_y(1-\nu^2)} = \frac{30 \times 10^6 \times 7.970}{12(1-0.3^2)} = 2.189 \times 10^7 \quad \text{lb-in} \quad (9)$$

$$h_x = \frac{4.44}{12} = 0.37 \quad \text{in} \quad (10)$$

$$D_y = \frac{E I_y}{S_x(1-\nu^2)} = \frac{30 \times 10^6 \times 20.815}{16(1-0.3^2)} = 4.287 \times 10^7 \quad \text{lb-in} \quad (11)$$

$$h_y = \frac{5.94}{16} = 0.37 \quad \text{in} \quad (12)$$

The thickness of the equivalent orthotropic plate is:

$$h = \frac{h_x + h_y}{2} = 0.37 \quad \text{in} \quad (13)$$

$$\bar{h} = \frac{2h_x h_y}{h_x + h_y} = 0.37 \quad \text{in} \quad (14)$$

The non-dimensional geometry parameters are:

$$\rho = \frac{L}{B} \sqrt[4]{\frac{D_y}{D_x}} = \frac{96}{168} \sqrt[4]{\frac{4.287 \times 10^7}{2.189 \times 10^7}} = 0.676 \quad (15)$$

$$\eta = \sqrt{\frac{I_{px} I_{py}}{I_x I_y}} = \sqrt{\frac{6.515 \times 16.367}{7.970 \times 20.815}} = 0.80 \quad (16)$$

$$\gamma = (1+\nu) \frac{\sqrt{h_x h_y}}{h_p} - \nu \frac{\sqrt{h_x h_y}}{\bar{h}} \quad (17)$$

$$= 1.3 \frac{\sqrt{0.37 \times 0.37}}{0.25} - 0.3 \frac{\sqrt{0.37 \times 0.37}}{0.37} = 1.627 \quad (18)$$

*Equivalence between the orthotropic and the stiffened plate can imply equal strain energy or equal rigidity. See ref. III-5 of the bibliography.

The non-dimensional load parameters are:

$$Q^* = \text{lateral load} = 1$$

$$N_x^* = \text{inplane compressive load in the x-direction} = 0.2$$

$$N_y^* = \text{inplane compressive load in the y-direction} = 0.4$$

The corresponding dimensional loads are as follows:

$$\bar{q} = Q^* \frac{\pi^4 D_y h}{B^4} = 1.94 \text{ p.s.i.} \quad (19)$$

$$\bar{N}_x = N_x^* \frac{\pi^2 D_x}{L^2} = 4,689.4 \text{ pounds per inch} \quad (20)$$

$$\bar{N}_y = N_y^* \frac{\pi^2 D_y}{B^2} = 5,996.4 \text{ pounds per inch} \quad (21)$$

The charts in [14] were entered using the above computed parameters and the bending stress, membrane stress, etc., were determined by interpolation and are shown in Table 1.

ICES STRUDL II [47] was used next to determine the stresses in the gross panel under the same loading condition. Only one quarter of the gross panel was discretized with symmetry conditions applied at the appropriate locations. For the lateral load analysis the gross panel was considered as superposition of a plate in bending plus a plane grid made by the stiffener. Rectangular bending elements were used of the type defined in STRUDL as BPR [47] "Bending Plate Rectangle". The stiffeners were modeled as beam elements of prismatic cross sections under bending and torsion. Due to the presence of the inplane loads the "stretching" degrees of freedom, i.e., plane stress and truss action were also incorporated. Figure 4 shows the finite element mesh used, the symmetry conditions and the boundary conditions. Table 1 shows the computed stresses.

Additional computation was made using the finite element program "SOLID SAP". Two kinds of discretized models were used. First, beam and plate elements were assembled to model the gross panel in a similar manner as used in the ICES STRUDL program. Then orthotropic plate elements were used to model the gross panel. The properties of the orthotropic plate elements are the same as obtained for the use with the design charts [14].

The gross panel was modeled next as a grillage or a system of discrete intersecting beams. Each beam consists of the stiffener plus the effective breadth of plating as described earlier. Additional results based on simple beam-column analysis were obtained and both results are shown in Table 1.

TABLE 1 - COMPARISONS OF METHODS OF GROSS PANEL ANALYSES

		Membrane Stress (p.s.i.)	Bending Moment (lb-in/in)	Bending Stress (p.s.i.)	Total* Stress (p.s.i.)	Percentage Difference**
Orthotropic Plate Analysis	1st order	16,150	2,335	7,170	23,320	-11%
	2nd order	16,150	2,420	7,435	23,585	-10%
Finite Element SOLID SAP	Beam and Plate Elements	16,292	3,256	9,993	26,285	+0.4%
	Orthotropic Plate elements	16,180	2,200	6,753	22,933	-12%
Finite Element ICES STRUDL		16,155	3,267	10,031	26,186	--
Grillage Analysis		16,152	3,117	9,569	25,721	+2%
Simple Beam Theory		16,152	4,569	14,032	30,184	+15%

*Stresses indicated in the table are at $x = 0, y = B/2$ (Figure 1).

**Percentage difference is taken with respect to ICES STRUDL results.

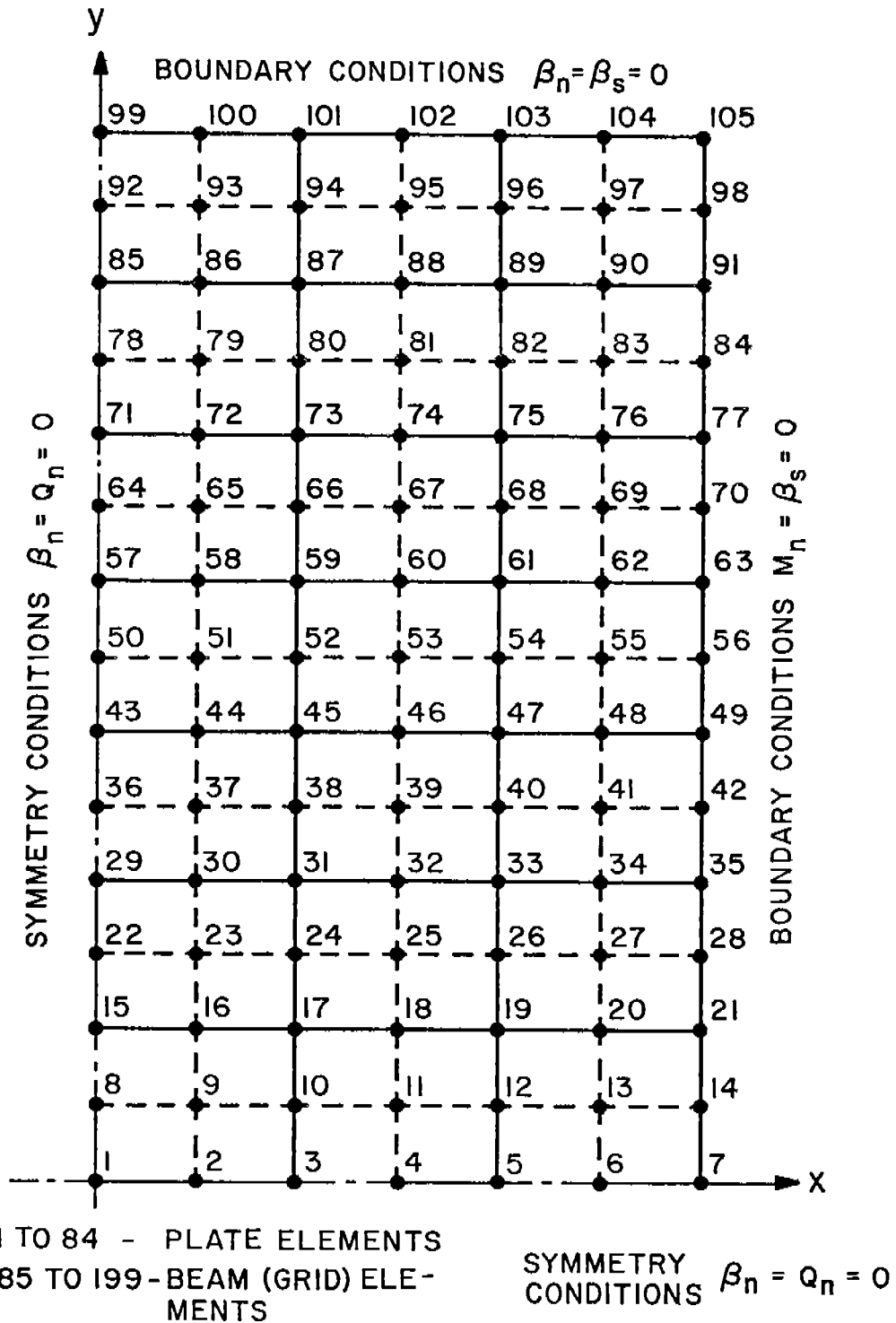

FIGURE 4 - MESH OF ONE QUARTER OF THE GROSS PANEL

The percentage difference in the total stress (membrane plus bending) of the different methods of analysis taken with respect to ICES STRUDL results is shown in the last column of Table 1. As expected, the simple beam results are the most conservative with a difference of about 15% above STRUDL results. The first and second order orthotropic plate analyses, using charts presented in [14] gave close results to the SOLID SAP finite element analysis, using orthotropic plate elements. The difference between these results is of the order of 2%. The grillage analysis gave close results to the finite element calculations (2% difference). The same computer program was used for both calculations and the difference is only in the manner of representing the gross panel. In general, the difference between the results of the different methods of analyses is within the engineering limits of accuracy.

The ranges over which the methods of gross panel analysis can be used are categorized as follows:

(1) Linear elastic behavior (first order theory): In this range the limitation includes small deflection relative to the plate thickness and the requirement that the stresses remain within the linear elastic range, i.e., Hooke's Law applies. In addition, the effect of shear deformation is neglected, i.e., Kirchhoff's assumption is upheld. The first of these limitations is satisfied when the ratio of the maximum deflection to the plate thickness "h" is less than 0.50. The last condition is satisfied when the plate thickness is small relative to the other dimensions "a" and "b" of the plate ($a, b/h > 40$). Finally, the direct stress in the direction perpendicular to the plane of the plate is considered negligible so that the problem may be treated as a two-dimensional instead of a three-dimensional problem in elasticity. This assumption is again satisfied when plate thickness is small relative to the other dimensions of the plate. The bending and membrane stresses are considered to be uncoupled if inplane tensile or compressive loads are present, in addition to the lateral load.

(2) Elastic buckling (second order linearized analysis): The effect of the external inplane loads on the equilibrium equations is considered in this type of analysis, thus coupling the membrane and bending stresses. The deflection, however, is still assumed to be small relative to the plate thickness ($w/h < 0.5$). All other limitations stated under (1) above are still upheld. In the absence of lateral loads, the solution of the resulting linearized differential equation provides a set of homogenous linear algebraic equations. For a non-trivial solution, the determinant must equal to zero (buckling criterion). This gives a solution in the form of discrete values (eigenvalues) from which the buckling loads are determined. The smallest of these gives the critical buckling load.

In the presence of lateral loads, the criteria for determining the buckling loads is obtained by setting the resulting deflection solution equal to infinity, i.e., by setting the denominator of the equation equal to zero.* A similar procedure is used when the effect of initial deflection of the plate is included in problem formulation.

The energy method (instead of the direct solution of the linearized differential equation) may be also used for determining the buckling loads. An expression for the total strain energy can be formulated and equated to the work done by the external loads. Minimizing the resulting equation with respect to

*The resulting critical load in this case is the same as that determined when the lateral load is not present.

the unknown coefficients in the assumed deflection surface provide a set of homogeneous algebraic equations. From these equations the buckling loads are determined by setting the determinant equal to zero.

In Section 4 of this report some collected and some developed formulations of the buckling loads under a variety of loading combinations and stiffeners and plate properties are presented and further discussed. Interaction curves have been developed which give the critical combination of the biaxial loads for various aspect ratio of the gross panel and various ratios of stiffener's flexural rigidity to the plate flexural rigidity.

(3) Inelastic buckling: One of the limitations in item 2 above (elastic buckling) is that the stresses must remain within the linear elastic range. This is the case for slender plates and grillages, i.e., as long as the slenderness ratio b/h is above a certain limit which depends on the material properties. For structural steel of $E = 30 \times 10^6$ p.s.i., $\nu = 0.3$, yield stress of about 34000 p.s.i. and proportional limit of 30000 p.s.i., this limiting value of b/h is about 60 if the plate is simply supported and compressed in one direction only. For b/h lower than this value experiments have shown that the yield stress becomes a limiting value.

Under biaxial compression, the limiting value of b/h depends on the ratio of the x - and y -compressive loads. For a structural steel of the same properties used above and for a simply supported square plate subjected to biaxial compressive stress in one direction equal to three times the compressive stress in the other direction, the limiting value of b/h is about 64.

Beyond the proportional limit of the material the modulus of elasticity E ceases to be constant. In the range between the proportional limit and the yield stress it is usual to use in the mathematical formulation of the problem the tangent modulus $E_t = \frac{d\sigma}{d\epsilon}$ instead of the elastic modulus E . This is done at a selected number of stress points between the proportional limit and the yield stress and the corresponding tangent modulus is determined from the stress-strain relation of the material. Based on these values of σ and E_t the corresponding values of b/h are determined and plotted versus the critical stress.

If the compression test diagram for the stress-strain relation is not available, an analytic expression representing it may be utilized. The formula for the tangent modulus can be then obtained by differentiation. If the material has a well defined yield point such as structural steel, the following expression for the tangent modulus may be used:

$$E_t = \frac{d\sigma}{d\epsilon} = E \frac{\sigma_{yp}^{-\sigma}}{\sigma_{yp}^{-k\sigma}} \quad (22)$$

This expression gives $E_t = 0$ at $\sigma = \sigma_{yp}$ and $E_t = E$ = elastic modulus for $\sigma = 0$. "k" is a parameter which depends on the material properties. The value $k = 1$ corresponds to Hooke's Law, i.e., $\sigma = E \epsilon$. The value of k for structural steel may be taken between 0.96 to 0.99.

(4) Non-linear analysis including large deflection and post-buckling behavior: In the previous categories, the effect of the deflection (or its derivatives) on the strain components of the middle plane of the plate was ignored. This is valid as long as the deflection remains small and the middle plane of the plate remains unstretched. When the deflection becomes large compared to plate thickness (as is the case when the plate buckles), the effect of the deflection on the strain components must be included. These strain-displacement relations can be then combined with the stress-strain relations and with the use of Airy's stress function, a fourth order partial differential equation representing the compatibility of displacements can be obtained, the "compatibility" equation. The equilibrium in direction perpendicular to the plane of the plate provides the second fourth order partial differential equation; the "equilibrium" equation. These two coupled equations can be then solved for the deflection and the stress function. The membrane and bending stresses can be determined from the stress function and deflection, respectively.

This analysis has been used to develop design charts for gross stiffened panels under combined biaxial inplane loads and lateral loads [14].

(5) Failure analysis (non-linear): The material non-linearities in the failure range of the gross panel must be considered. Two distinct types of approximate analysis may be used. If the lateral load acting on the gross panel is combined with small compressive biaxial loads, limit analysis may be used to estimate the ultimate strength of the panel. On the other hand, if the compressive biaxial loads are dominant then several modes of failure are possible. The lowest of these modes depends primarily on the relative flexural rigidity of the plate to that of the stiffeners and the stiffeners' torsional rigidity. The failure modes include failure of plates between stiffeners, failure of longitudinal stiffeners under pure buckling, torsional-buckling (tripping) of longitudinal stiffeners, or failure of the grillage as a whole. These failure modes are discussed in detail later in this section.

B. Comparison with Experiments

Comparisons between experimental measurements and analytical results were considered next. Unfortunately, the scarcity of the experimental data on stiffened panels under biaxial compressive loads and lateral pressure limited the scope of the comparison. Ship Structure Committee Report SSC-223 [49] provided some information in this regard. Reference [50] provided also some good additional experimental data. This reference, however, gives experimental results of a series of tests on full-scale welded steel grillages under uniaxial compressive loads combined in some cases with lateral pressure. A recent experimental study, not yet published on stiffened panels under biaxial loads is being carried out in the Civil Engineering Department at the Imperial College, London. A recent Det norske Veritas report [9] and other recent correspondence [51,52] indicated also the scarcity of experimental results on stiffened panels under biaxial compressive inplane loads and lateral pressure.

Most of the experimental work on stiffened panels is carried to the ultimate strength of the panel. For the purpose of comparisons, several analytical methods for prediction of the ultimate strength of ship grillages were examined [14, 24, 25,

26, 31, 34, 36, 42]. In particular, plastic limit analysis of grillages was given considerable attention. The plating was considered as effective flange to the stiffeners, i.e., grillage representation. The usual assumption of neglecting the influence of the shear force on the formation of the plastic hinges was made [24]. The torsional rigidity of the stiffeners of typical ship gross panel is usually small and its effect on this particular mode of failure of the gross panel as a whole is also small.* An upper bound of the collapse load can be then established by choosing a one-parameter deformation pattern and equating the rate of internal energy dissipation to the rate of external work. The correct collapse mechanism is the one which gives the lowest upper bound. This type of limit analysis can be employed if the inplane compressive forces are relatively small and the collapse is primarily due to large lateral pressure. In this case the inplane loads tend to reduce the magnitude of the plastic moment, but no instability (buckling) is assumed to take place. An interaction relationship of bending and inplane loads can be used to determine the effect of the inplane force on the plastic modulus, as given later in this section.

Simplified plastic limit analysis based on the above assumptions was developed in this study on the bases of the work presented in refs. [12,19,24,25,26] for the case when the lateral load is combined with small biaxial inplane loads. The resulting governing equations for the ultimate lateral pressure are:

$$P_{ultimate} = \frac{P_c(n'+1)}{B} \quad (23)$$

where P_c is given by: (1) For fixed end transverse stiffeners,

$$P_c = \frac{8(m'+1)^2 (M_{te} + M_{tc})}{m'(m'+2) L^2} + \frac{(m'+1)}{L} R_c \quad m' = \text{even} \quad (24)$$

or

$$P_c = \frac{8(M_{te} + M_{tc})}{L^2} + \frac{(m'+1)}{L} R_c \quad m' = \text{odd} \quad (25)$$

(2) For simply supported transverse stiffeners,

$$P_c = \frac{8(m'+1)^2}{m'(m'+2)L^2} M_{tc} + \frac{(m'+1)}{L} R_c \quad m' = \text{even} \quad (26)$$

or

$$P_c = \frac{8M_{tc}}{L^2} + \frac{(m'+1)}{L} R_c \quad m' = \text{odd} \quad (27)$$

*The stiffeners may trigger, however, the other modes of failure such as tripping, or local buckling which may lead to failure.

The values of the interaction forces between the longitudinal and transverse stiffeners " R_c " are given by:

(1) For fixed end longitudinal stiffeners,

$$R_c = \frac{8(n'+1)(M_{1e} + M_{1c})}{n'(n'+2) B} \quad n' = \text{even} \quad (28)$$

or

$$R_c = \frac{8(M_{1e} + M_{1c})}{(n'+1) B} \quad n' = \text{odd} \quad (29)$$

(2) For simply supported longitudinal stiffeners,

$$R_c = \frac{8(n'+1) M_{1c}}{n'(n'+2) B} \quad n' = \text{even} \quad (30)$$

or

$$R_c = \frac{8M_{1c}}{(n'+1) B} \quad n' = \text{odd} \quad (31)$$

where,

$P_{ultimate}$ = ultimate uniform pressure

R_c = interaction forces between longitudinal and transverse stiffeners

M_{te} = plastic moment of transverse stiffener at ends

M_{tc} = plastic moment of transverse stiffener at center

M_{1e} = plastic moment of longitudinal stiffener at ends

M_{1c} = plastic moment of longitudinal stiffener at center

B = length of longitudinal stiffeners

L = length of transverse stiffener

m' = number of longitudinal stiffeners

n' = number of transverse stiffeners

When only lateral pressure is present then $M_{1e} = M_{1c}$ and $M_{te} = M_{tc}$ and one may replace $M_{1e} + M_{1c}$ and $M_{te} + M_{tc}$ with $2M_1$ and $2M_t$, respectively, in the above formulas. M_1 and M_t are the plastic moments for the longitudinal and transverse stiffeners, respectively.

For the case of a stiffener with a web-section area A_W and a flange area A_F attached to a plate of area A_P and subjected to lateral load only, the plastic moment is given by:

$$M_{\text{plastic}} = [S_F + S_W + S_P] \sigma_{yp} = S \sigma_{yp} \quad (32)$$

in which S_F , S_W , and S_P are the contribution of the flange, web, and plate, respectively, to the plastic modulus S , as defined by (32). S_F , S_W , and S_P can be determined in the usual manner as, for example, given in reference [53]. Figure 5 shows the formulas for determining their values as obtained from [53].

When the section is subjected to combined inplane and lateral loadings, the plastic modulus S is reduced to $S - 2\bar{m}$, where \bar{m} is the moment about the equal area axis (E.A.A.) of the area between the equal area axis and the plastic neutral axis (P.N.A.). The position of the latter axis is defined by g_1 , as given by the formulas shown in Figure 6 obtained from reference [53].

When both the equal area axis and the plastic neutral axis lie in the web or in the plate, the modified plastic modulus S' due to axial force can be reduced to the following simple forms:

$$S' = S - \left(\frac{A^2}{4t_w}\right) \bar{n}^2 \quad (33)$$

$$S' = S - \left(\frac{A^2}{4s}\right) \bar{n}^2 \quad (34)$$

The first of these equations is for the case when both axes lie in the web and the second for the case when they lie in the plating. " \bar{n} " is the squash load ratio defined as the mean axial stress over the yield stress and " s " and " t_w " are the plate breadth and web thickness, respectively. (See Figure 6,)

Limit analysis becomes complicated if the inplane forces contribute appreciably to the collapse failure of the grillage particularly if arbitrary shapes of stiffener cross sections are considered. For large inplane forces, it is seen that the grillage stability problem (or local buckling) will become more important, i.e., stability conditions rather than limit analysis would be governing in this case.

The developed procedure described above was applied to three gross panels. The first of these is shown in Figure 1. It is identical to the one considered in the previous behavior analyses using several methods. The second and third gross panels have the same dimensions and stiffener characteristics as grillages numbered 1b and 4b of reference [50]. The experimental collapse loads for these grillages are 15 p.s.i. lateral pressure with 12.1 t.s.i. average uniaxial compressive stress for grillage "1b"; and 8 p.s.i. lateral pressure with 13.5 t.s.i. average compressive stress for grillage "4b". The results of the limit analysis together with the dimensions of the three gross panels are shown in Table 2. All edges are simply supported for gross panels 2 and 3. Other comparisons between limit analysis and experiments without the presence of inplane loads are available in the literature [25, 26] and are favorable.

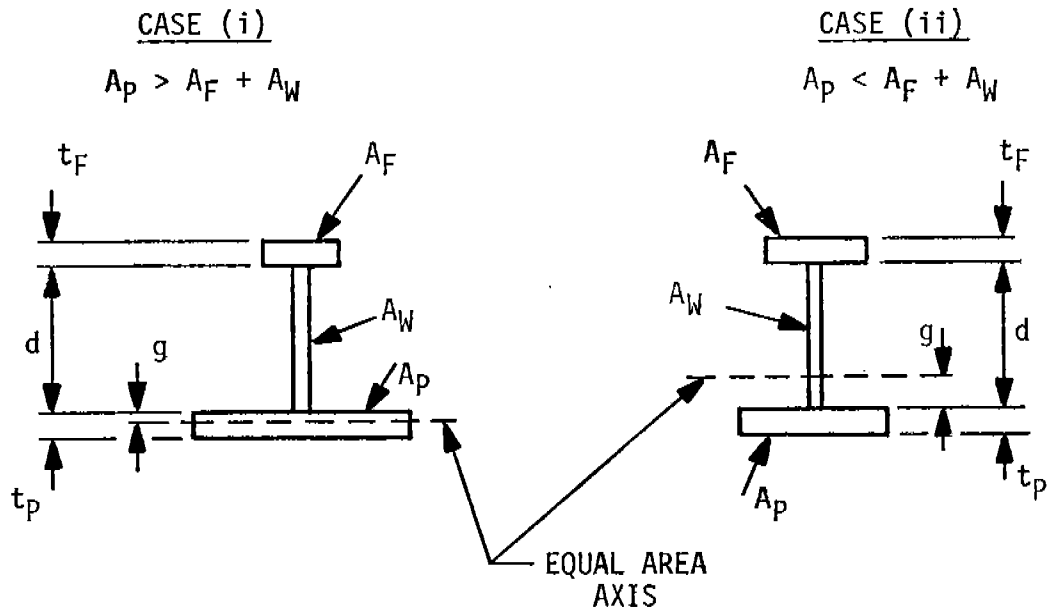

	CASE (i)	CASE (ii)
C_1	$(A_p - A_w - A_f)/2A_p$	$(A_w + A_f - A_p)/2A_w$
C_2	$C_1^2 - C_1 + 1/2$	
g	$C_1 t_p$	$C_1 d$
S_f	$A_f(d + g + 1/2 t_f)$	$A_f(d - g + \frac{1}{2} t_f)$
S_w	$A_w(\frac{1}{2} d + g)$	$A_w d C_2$
S_p	$A_p t_p C_2$	$A_p(g + \frac{1}{2} t_p)$

FIGURE 5 - MEMBER UNDER BENDING MOMENT ONLY, REF. [53]

FORMULAS FOR CALCULATING POSITION OF THE PLASTIC NEUTRAL AXIS.

FOR A MEMBER SUBJECTED TO BENDING AND AN AXIAL LOAD THE DISTANCE OF THE PLASTIC NEUTRAL AXIS FROM THE WEB-SIDE OF THE PLATING IS DEFINED BY g_1 , WHICH CAN BE CALCULATED FROM FORMULA (1), (2) OR (3) BELOW, WHICHEVER IS APPROPRIATE. IN ALL CASES FORMULA (1) SHOULD BE EVALUATED FIRST.

$$(1) \quad g_1 = \frac{1}{2t_W} [A_F + A_W - A_P \mp A\bar{n}]$$

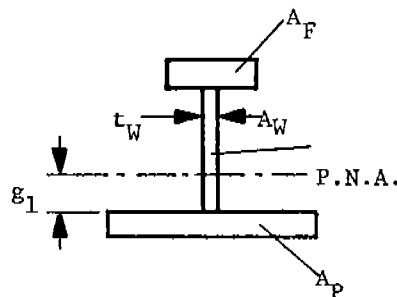

IF FORMULA (1) GIVES A NEGATIVE VALUE FOR g_1 , THEN THE PLASTIC NEUTRAL AXIS LIES IN THE PLATING, AND FORMULA (2) SHOULD BE USED.

$$(2) \quad g_1 = \frac{1}{2S} [A_P - A_F - A_W \mp A\bar{n}]$$

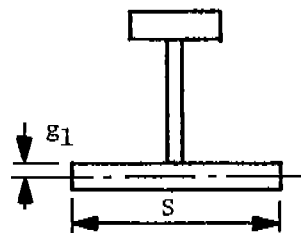

IF FORMULA (1) GIVES $g_1 > d$, THEN THE PLASTIC NEUTRAL AXIS LIES IN THE FLANGE, AND FORMULA (3) SHOULD BE USED.

$$(3) \quad g_1 = \frac{1}{2b} [A_F - A_W - A_P \mp A\bar{n}] + d$$

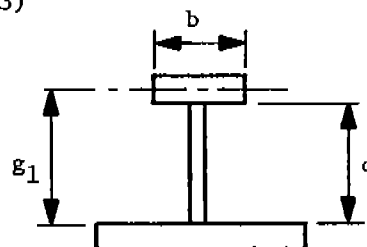

WHERE: $A = A_P + A_W + A_F$

\bar{n} = THE SQUASH LOAD RATIO WHICH IS EQUAL TO THE MEAN AXIAL STRESS OVER THE YIELD STRESS.

NOTE: THE UPPER SIGN PRECEDING $A\bar{n}$ SHOULD BE USED WHEN THE STRESS DUE TO THE AXIAL LOAD ALONE IS OF THE SAME KIND (TENSILE OR COMPRESSIVE) AS THAT IN THE FLANGE DUE TO THE BENDING MOMENT. THE LOWER SIGN APPLIES WHEN THESE STRESSES ARE OF OPPOSITE KINDS.

EXAMPLE:

\bar{n} = MOMENT OF SHADED AREA ABOUT E.A.A.

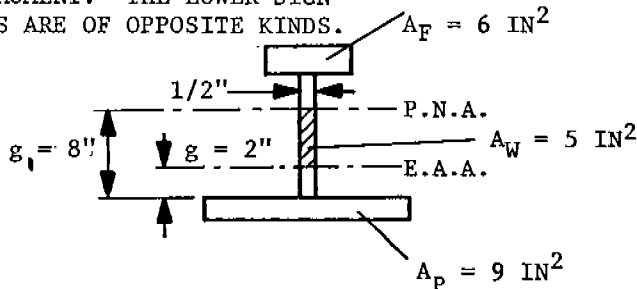

FIGURE 6 - MEMBER UNDER BENDING AND AXIAL LOAD, REF. [53].

TABLE 2 - LIMIT ANALYSIS APPLIED TO THREE GROSS PANELS

Configuration Number	Plate Thickness	Longitudinal Beams					Transverse Beams					$P_{ult}(\text{psi})$
		spacing	D	B_2	t_2	t_w	spacing	D	B_2	t_2	t_w	
1 L = 96" B = 168"	0.25"	16"	5"	3"	0.25"	0.25"	12"	3.5"	2.5"	0.25"	0.25"	$5.208 \times 10^{-4} \sigma_{yp}$
2 L = 126" B = 240"	0.31"	24"	6"	3"	0.56"	0.28"	48"	10"	5"	0.72"	0.36"	$6.440 \times 10^{-4} \sigma_{yp}$
3 L = 126" B = 240"	0.25"	10"	3"	1"	0.25"	0.179"	48"	8"	4"	0.64"	.329"	$3.366 \times 10^{-4} \sigma_{yp}$

In the above table, L is the length of trans. stiffeners, B is the length of longt. stiffeners, D is the depth of the stiffener, B_2 is the flange breadth, t_2 is the flange thickness, t_w is the web thickness and σ_{yp} the yield stress.

As was mentioned earlier, if the inplane loads are sufficiently small to cause no local or overall instability, the ultimate strength and the collapse mechanism can be determined using the simplified procedure developed above. Alternatively, if the loads acting on the gross panel did not increase proportionally shakedown analysis is more suitable. In this case if the shakedown load is exceeded, plastic flow will continue during each cycle of load application leading eventually to failure either by: (1) alternating plasticity, or (2) incremental collapse.

If the inplane loads are dominant then the stability and post-buckling behavior become the governing considerations rather than the limit analysis. Several possible modes of failure may arise [50] in this case. These are:

(1) Plate failure between stiffeners: In this collapse mode, the ultimate strength of the plate is exceeded before extensive yield occurs in the stiffeners, i.e., the ultimate load for the stiffened panel is reached before stiffeners failure occur. Reliable estimates can be made of the ultimate strength of isotropic (unstiffened) plates under uniaxial compression. (See expressions in the next section.) Some interaction relations between compression and lateral loads are also available.

(2) Flexural buckling of stiffeners: In this collapse mode failure occurs by column-like flexural buckling of stiffeners and plating between transverse web frames. Because of the initial deformation of the stiffeners and the direction of the lateral load, buckling often occurs towards the stiffeners. But buckling may also occur towards the unstiffened side of the plate and in this case, flexural buckling may be coupled with sideways tripping of the stiffeners.

Two mechanisms leading to the flexural buckling of stiffeners mode of failure are possible. The plate between stiffeners may first buckle leading to a reduction in the total effectiveness of the stiffeners' rigidity and to column-buckling. The second mechanism postulates that column-buckling may first occur with fully effective plating if the stiffeners are very flexible.

When column-buckling is purely flexural this failure mode can be investigated using inelastic column analysis based on (a) numerical solutions using beam-column elastic-plastic relations or (b) incremental finite element method.

(3) Tripping of stiffeners (Lateral-torsional buckling): This mode of failure is likely to occur in flexurally stiff longitudinals which have low lateral torsional rigidity. It may be coupled with the flexural mode if buckling occurs towards the plating.

Some elastic analysis exists of torsional buckling coupled with flexure, e.g., by F. Bleich [54], but no satisfactory method seems to exist for inelastic tripping of stiffeners welded to continuous plating and for the prediction of the inelastic collapse strength.

(4) Overall gross panel buckling: This collapse mode involves the overall gross panel buckling over its entire length with bending of both transverse and longitudinal stiffeners. Two mechanisms leading to this failure mode are possible: (a) reduced plating stiffness due to buckling between stiffeners, and (b) local stiffeners tripping.

For uniform gross panel buckling loads and modes, the entire gross panel under uniaxial compression can be estimated from orthotropic plate formulas [3, 6, 7, 14, 15]. This analysis was further developed to include gross panel buckling under biaxial load. Design charts were developed showing the combination of critical loads for various aspect ratios and rigidities of both the plate and stiffeners. These charts are presented in the next section of the report with examples showing their use.

In very slender gross panels for which the elastic buckling stress is well below the yield point a significant post-buckling reserve may exist. The ultimate strength in this case can be estimated using the von Kármán effective width technique. Some curves are shown in reference [14] which give the effective width of the panel which can be used in an iterative manner to estimate the ultimate strength under this failure mode.

4. RECOMMENDATIONS AND DISCUSSION

In the first part of this section some suitable expressions for estimating the buckling loads of gross panels are recommended and discussed. Some interaction relations between the biaxial compressive loads are developed and presented with examples of applications given in Appendix II. In the second part of the section some recommendations are made for methods of evaluating the gross panel behavior and methods for estimating its ultimate strength indicating areas of lack of reliable procedures. A test program is discussed in the final section with goals and objectives outlined.

A. Expressions for Estimating the Critical Buckling Loads in Gross Panels

(1) Elastic Buckling

(a) Plating between stiffeners (isotropic plates): For simply supported plates under uniaxial compression, the critical stress σ_{xcr} is given by the usual expression [54, 55]:

$$\sigma_{xcr} = k \frac{\pi^2 D}{a^2 h} \quad (35)$$

where

$$k = \left(m + \frac{1}{m} \frac{a^2}{b^2}\right)^2 \quad (36)$$

$$D = \frac{Eh^3}{12(1-\nu^2)} \quad (37)$$

h is the plate thickness, b and a are the plate breadth and length between stiffeners, and m is the number of half waves in which the plate buckles. For other boundary conditions, the coefficient k is given in many books as for example [54, 55, 56].

For plates under biaxial compression the critical buckling combination of the inplane stresses σ_x and σ_y can be determined from [55]:

$$\sigma_x m^2 + \sigma_y n^2 \frac{a^2}{b^2} = \sigma_e \left(m^2 + n^2 \frac{a^2}{b^2}\right)^2 \quad (38)$$

where

$$\sigma_e = \frac{\pi^2 D}{a^2 h} \quad (39)$$

D is given by equation (37).

Equation (38) reduces to equations (35) and (36) when $\sigma_y = 0$ and $n = 1$, i.e., uniaxial load conditions. Values of m and n (number of half waves in which the plate buckles in the x - and y -directions, respectively) should be chosen such that the smallest values σ_x and σ_y will result. The following inequalities can be used in this regard.

- (i) If σ_x lies within the following limits, the values $m = 1, n = 1$ should be used in calculating the critical value of σ_y

$$\sigma_e(1 - 4 \frac{a^2}{b^2}) < \sigma_x < \sigma_e(5 + 2 \frac{a^2}{b^2}) \quad (40)$$

- (ii) If the value of σ_x is larger than the upper limit of inequality (40) and lies between the following limits then the values $n = 1, m = i$ (where $i = 2, 3, 4$) must be used in determining the critical value of σ_y .

$$\sigma_e(2i^2 - 2i + 1 + 2 \frac{a^2}{b^2}) < \sigma_x < \sigma_e(2i^2 + 2i + 1 + 2 \frac{a^2}{b^2}) \quad (41)$$

- (iii) If the value of σ_x is smaller than the lower limit of inequality (40), then the values $m = 1, n = i$ ($i = 2, 3, \dots$) must be used in determining the critical value of σ_y if the following inequality holds.

$$\sigma_e[1 - i^2(i-1)^2 \frac{a^4}{b^4}] > \sigma_x > \sigma_e[1 - i^2(i+1)^2 \frac{a^4}{b^4}] \quad (42)$$

As an example, consider the case where the plate aspect ratio $\frac{a}{b} = 0.3$ and let the compressive stress $\sigma_x = 0.2\sigma_e$. Since σ_x is smaller than the lower bound of inequality (40), we must use the general inequality (42) which is satisfied by taking $i = 3$. Thus for $m = 1$ and $n = 3$, equation (38) gives

$$\sigma_x + 9 \sigma_y \frac{a^2}{b^2} = \sigma_e (1 + 9 \frac{a^2}{b^2})^2$$

from which the critical compressive stress is,

$$\sigma_{ycr} = 3.8 \sigma_e$$

(b) Flexural buckling of stiffeners: The critical stress " σ_{cr} " for the flexural buckling of a simply supported stiffener with an effective breadth of plating may be estimated from the usual Euler formula with shear deformation included [50, 54, 55 56]:

$$\sigma_{cr} = \frac{\pi^2 EI}{A a^2} \left[\frac{1}{1 + \frac{\pi^2 EI}{a^2 G A_s}} \right] \quad (43)$$

in which I is the effective moment of inertia of the stiffener with the attached plating, a is the length of the longitudinal stiffener between the transverse girders, A is the total cross section area and A_s is the effective shear area. For other boundary conditions, reference can be made to [54, 55, 56].

(c) Lateral-torsional buckling of stiffeners (tripping): The critical stress σ_{er} can be approximately estimated from a formulation due to Bleich [54]:

$$\sigma_{cr} = \frac{\pi^2 E}{(a/r_e)^2} \quad (44)$$

where a is the stiffener length and r_e is the effective radius of gyration. The effective radius of gyration for a variety of stiffener shapes and for stiffeners which can rotate with or without restraint around the enforced axis of rotation (intersection line with the plate) can be obtained from curves and expressions given in reference [54]. Other possible formulations such as discussed in [57] using folded-plate analysis can be used to estimate the tripping critical load.

(d) Overall grillage buckling: This buckling mode can be estimated from orthotropic plate analysis if the number of stiffeners in each direction exceeds three.* For gross panels under uniaxial compression the critical buckling load is given by [58]:

$$\sigma_{xcr} = k \frac{\pi^2 \sqrt{D_x D_y}}{h_x B^2} \quad (45)$$

where k is given by different expressions depending on the boundary conditions [58].

(i) For simply supported gross panels.

$$k = \frac{m^2}{\rho^2} + 2\eta + \frac{\rho^2}{m^2} \quad (46)$$

(ii) For gross panels with both loaded edges simply supported and both other edges fixed.

$$k = \frac{m^2}{\rho^2} + 2.5\eta + 5 \frac{\rho^2}{m^2} \quad (47)$$

*For gross panels with three stiffeners or less, the critical buckling loads can be determined from references [56] or [55].

- (iii) For gross panels with both loaded edges fixed and both other edges simply supported.

$$k = 2\eta + \delta \quad (48)$$

where δ is a parameter that has to satisfy the transcendental equation [58]:

$$\alpha_m \tan \frac{\alpha_m}{2} = \beta_m \tan \frac{\beta_m}{2} \quad (49)$$

where

$$\alpha_m = \frac{\pi^2 \rho^2}{2} \left[\delta - \sqrt{\delta^2 - 4} \right]$$

$$\beta_m = \frac{\pi^2 \rho^2}{2} \left[\delta + \sqrt{\delta^2 - 4} \right]$$

Thus for a given value of ρ ; δ which satisfies equation (49) must be determined and used in conjunction with equations (48) and (45) to determine the critical buckling load.

Equations (45) and (46) reduce to equations (35) and (36) when isotropic material properties are used. For gross panels of other boundary conditions reference [6] and [59] can be used to determine the factor k in equation (45).

For simply supported gross panels subjected to biaxial edge compression, the critical combination of the edge stresses σ_x and σ_y of the overall grillage buckling was developed using the energy method (see Appendix II). The resulting critical combination is governed by the following equation:

$$\frac{\sigma_x}{\sigma_x^*} m^2 + \frac{\sigma_y}{\sigma_y^*} n^2 = \frac{m^4}{\rho^2} + 2\eta m^2 n^2 + \rho^2 n^4 \quad (50)$$

Symbols used in equations (45) to (50) are defined as follows:

$$\rho = \frac{L}{B} \sqrt{\frac{4D_y}{D_x}} \quad ; \quad \eta = \frac{D_{xy}}{\sqrt{D_x D_y}}$$

$$\sigma_x^* = \frac{\pi^2 \sqrt{D_x D_y}}{h_x B^2} \quad ; \quad \sigma_y^* = \frac{\pi^2 \sqrt{D_x D_y}}{h_y L^2}$$

D_x and D_y are the flexural rigidities per unit width [14, 50].

D_{xy} twisting rigidity per unit width [14, 50].

h_x, h_y average cross sectional areas per unit width of effective plating and stiffeners in the x- and y-directions, respectively.

B gross panel breadth in the y-direction.

L gross panel length in the x-direction.

m, n number of half waves in which the gross panel buckles in the x- and y-directions, respectively.

For the approximate evaluation of the rigidity coefficients D_x, D_y and D_{xy} of an actual plate-stiffener combination reference should be made to [4, 5, 7, 10, 14].

Equation (50) reduces to (38) when isotropic material properties are used. In equation (50) the values of m and n should be chosen such that the smallest values σ_x and σ_y result. For this purpose some interaction curves have been developed [60] which assist in determining values of m and n to be used in (50) for different values of $\rho, \eta, \frac{\sigma_x}{\sigma^*}$ and $\frac{\sigma_y}{\sigma^*}$. Figures 7 to 14 show such interaction curves.

Examples of application of equation (50) and the interaction curves to actual ship grillages are given in Appendix II. Interpolation between the curves should not be performed because of the non-linear relationship between the variables $\rho, \eta, m,$ and n . Instead equation (50) should be used after determining the values of m and n.

The critical buckling load of gross panels can be also determined on the basis of discrete beam solution, i.e., grillage representation. Convenient charts for estimating such loads for elastically supported gross panels are given in reference [29].

It should be mentioned that, in general, plate buckling cannot be observed in full-scale experiments. The transition from the pre-buckling into the post-buckling range is usually not accompanied by a sudden increase in deflection because of presence of initial deflections and plate imperfection. For plates under uniaxial inplane and lateral loads reference [3] gives charts for the total deflection W_t , effective width and plate bending moment including initial deflections. Figure 15 is a sample of these charts taken from reference [3]. It shows clearly that a perfectly flat plate with no lateral load applied exhibits a theoretical bifurcation point of equilibrium. It also shows that the sudden rate of increase of plate deflection disappears with increasing initial deflection and lateral load. These initial deflections need not be very large to obscure the bifurcation point. Figure 15 shows also that the order of magnitude of the final deflection (in the post-buckling range) is almost independent of the initial deflection.

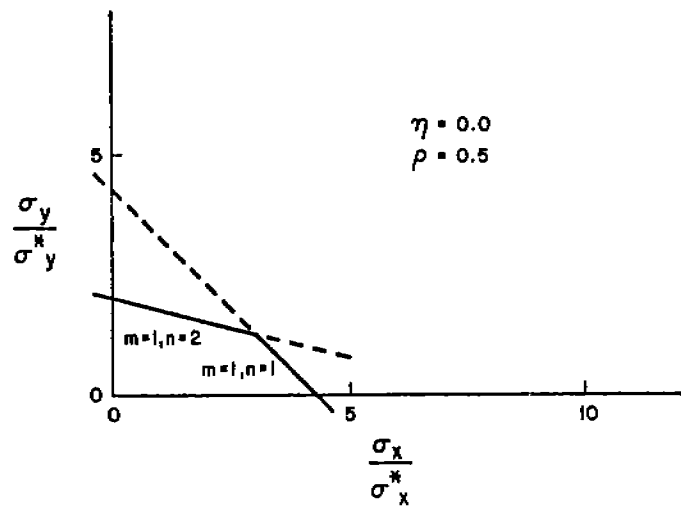

FIGURE 7 - BIAxIAL BUCKLING INTERACTION LINES

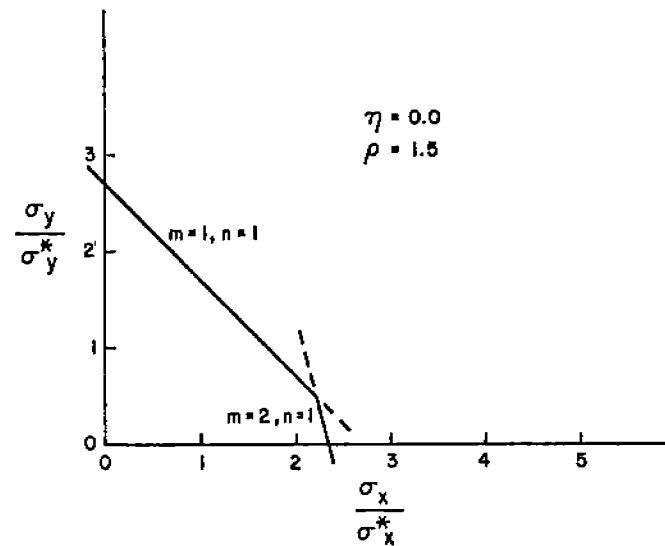

FIGURE 9 - BIAxIAL BUCKLING INTERACTION LINES

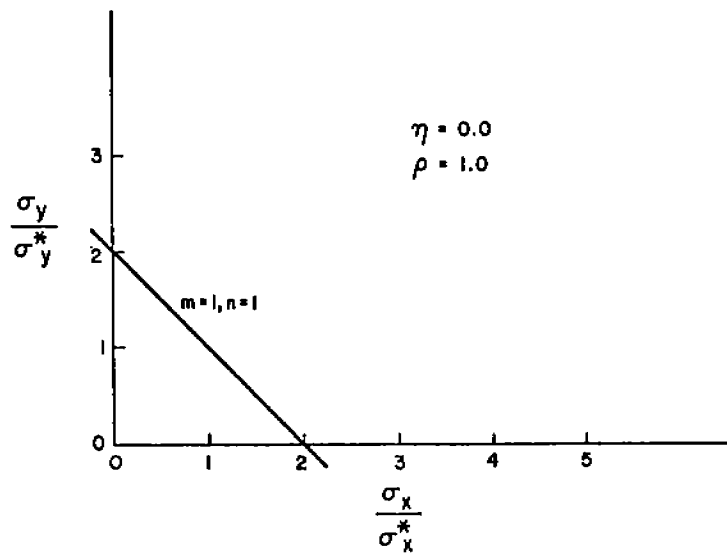

FIGURE 8 - BIAxIAL BUCKLING INTERACTION LINES

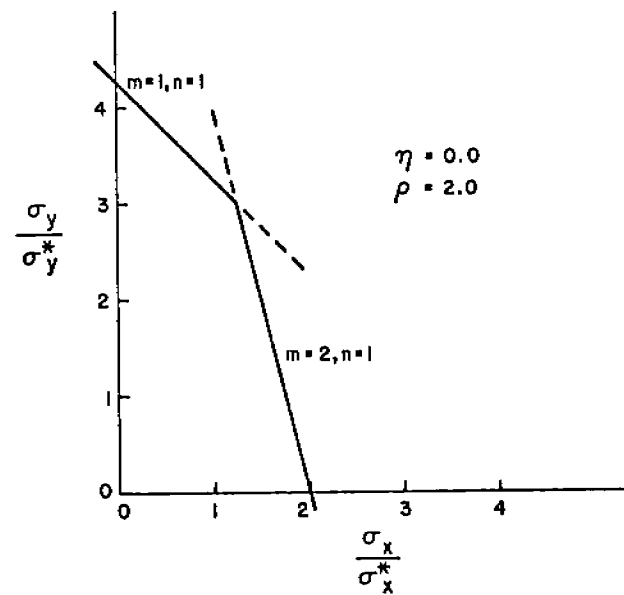

FIGURE 10 - BIAxIAL BUCKLING INTERACTION LINES

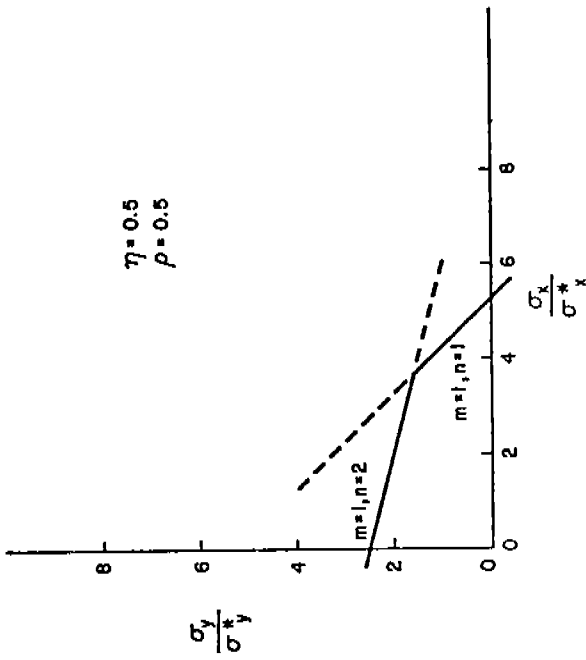

FIGURE 11 - BIAXIAL BUCKLING INTERACTION LINES

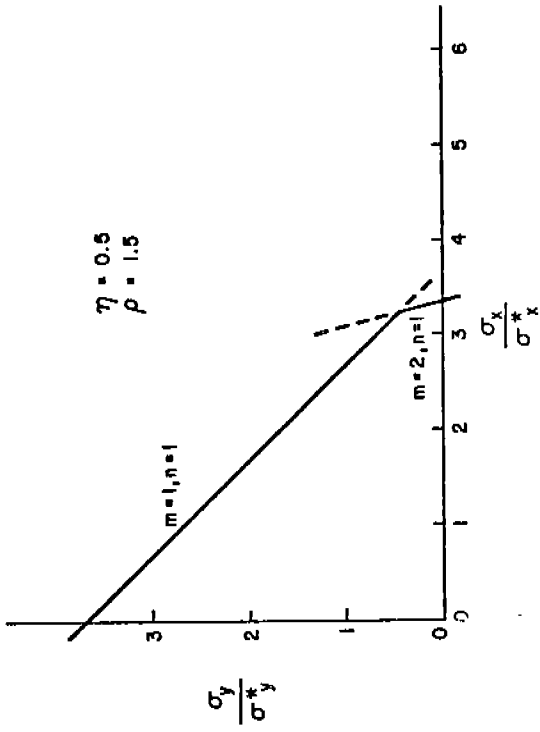

FIGURE 13 - BIAXIAL BUCKLING INTERACTION LINES

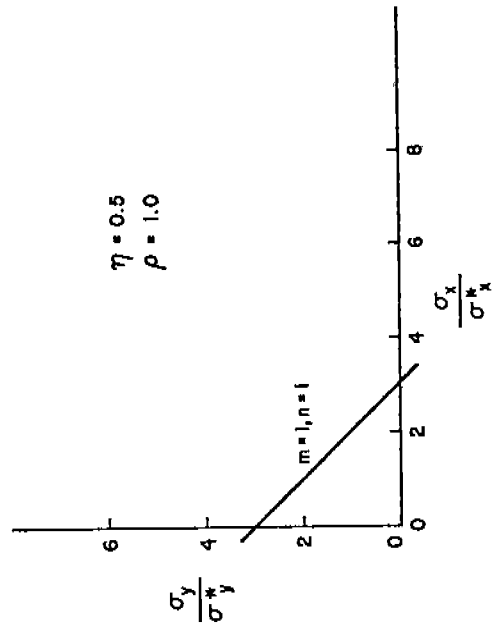

FIGURE 12 - BIAXIAL BUCKLING INTERACTION LINES

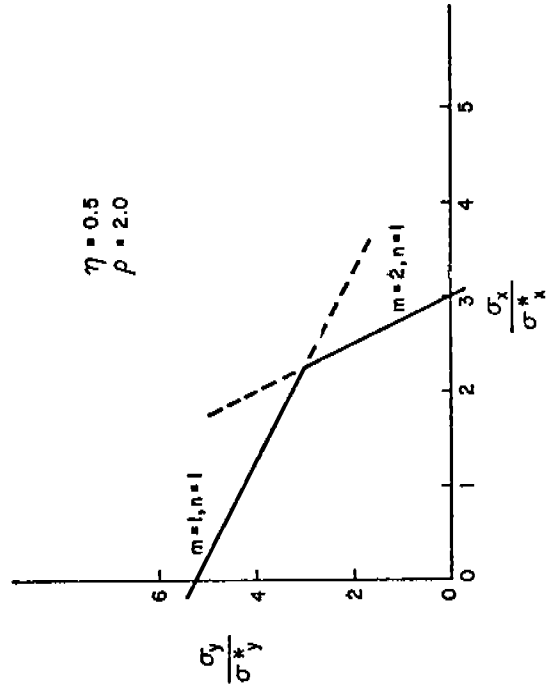

FIGURE 14 - BIAXIAL BUCKLING INTERACTION LINES

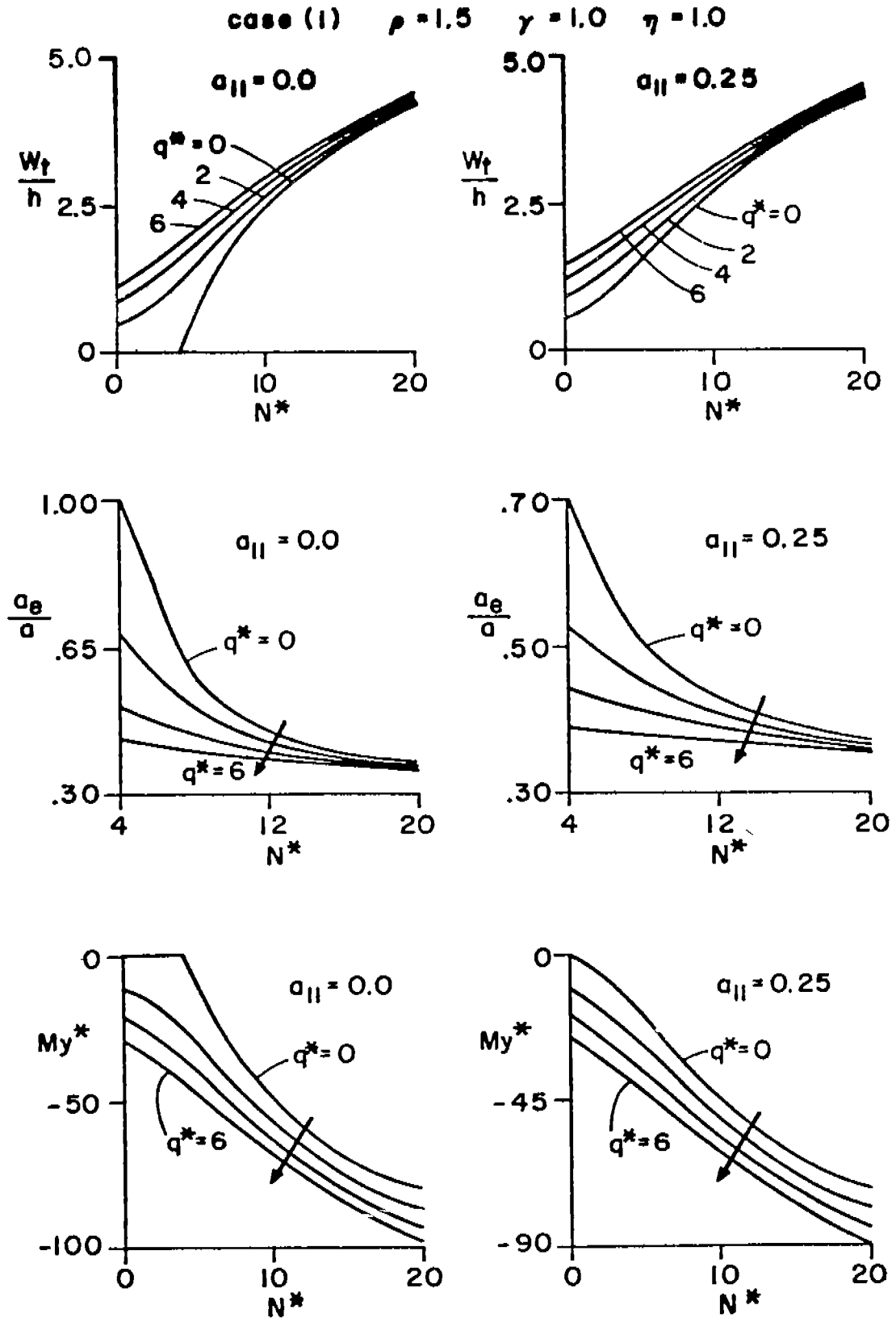

FIGURE 15 - EFFECT OF INITIAL DEFLECTION FROM REF. [3].

(2) Inelastic Buckling

As was mentioned in Section 3, if the slenderness ratio decreases below a certain limiting value which depends on the material properties, yielding may occur prior to buckling. Experiments have shown in general that plates and beams may buckle at any value of the slenderness ratio if the compressive stresses reach the yield point of the material. Between the proportional limit and the yield point the tangent modulus E_t instead of E can be used in most of the preceding elastic buckling formulations (equations 35 to 44) for predicting the inelastic buckling loads. The tangent modulus is to be determined from a compression-test diagram. In the absence of a compression-test diagram, the following expression may be used for materials with well-defined yield point such as structural steel:

$$E_t = E \frac{\sigma_{yp} - \sigma}{\sigma_{yp} - c\sigma} \quad (51)$$

Another formulation for the tangent modulus is given by Bleich [54]. in which σ_{yp} is the yield stress and the parameter c can be taken 0.96 to 0.99 for structural steel. He proposed the use of a quadratic parabola in the form:

$$E_t = E \frac{(\sigma_{yp} - \sigma) \sigma}{(\sigma_{yp} - \sigma_p) \sigma_p} \quad (52)$$

where σ_p is the proportional limit of the material. Faulkner suggested [31], however, that σ_p be taken as the structural rather than the material proportional limit.

For materials that exhibit pronounced strain-hardening, Ramberg-Osgood's [61] three parameter relation may be used [31]. From this relation, the tangent modulus is given by:

$$E_t = E \frac{1}{1 + \frac{3}{7} n_r (\sigma/\sigma_0)^{n_r-1}} \quad (53)$$

where σ_0 is the base stress when $E_s = 0.7E$ and n_r is empirical constant derived from curve fitting. Reference [62] gives typical values of σ_0 and n_r for a variety of materials.

B. Methods of Evaluating the Gross Panel Behavior and its Ultimate Strength

(1) Linear and Linearized Elastic Behavior

In this range, the different existing methods of examining the behavior of gross panels seem to be reliable and adequate. Based on the comparisons made in Section 3, the difference in the results of applying the various methods of analysis

(see Table 1) to a gross panel subjected to biaxial inplane and lateral loads fall within reasonable limits of engineering accuracy. In particular the finite element analysis [47, 48], orthotropic plate analysis [4, 5, 6, 7, 15] and grillage analysis [47, 48, 27, 29, 30] are suitable; each subject to certain limitations as discussed in Sections 2 and 3. The finite element method provides accurate geometric representation of the gross panel but requires more time and effort than the other two methods particularly if the latter methods are presented by design charts such as given in [4, 5, 6, 7, 29, 30].

(2) Non-linear Large Deflection Behavior

It is well known that buckling of ship gross panels as a whole may occur, in some cases, at rather low values of inplane compressive loads while the plating between the stiffeners sustain adequate (larger) buckling loads. This condition can be, generally, found in deck fields adjacent to hatch openings of transversely framed ships with lengths of 350 feet or more [67], and in bottom plating [70]. It has been indicated theoretically and experimentally [14, 66, 67] that, for slender gross panels, the buckling load of the gross panel as a whole can be exceeded by a certain amount without danger to the structure.*

Although the transition from the linear to the non-linear large-deflection behavior is usually characterized by the elastic buckling loads as given under "A" of this section, in some cases, however, the geometric non-linearities arise due to the action of large lateral pressure on the gross panel even though the biaxial inplane loads may be well below their critical value. In either case the effect of deflection (or its derivatives) on the strain-displacement relations must be considered in the analysis.

In the finite element method this requirement led to the formulation of the geometric stiffness matrix in addition to the usual axial-flexure linear stiffness matrix. The approaches to the solution of the non-linear governing equations can be achieved using either a direct iterative method (e.g., Newton-Raphson procedure), or an incremental model in which the loading is treated as a sequence of steps, with linearization of the analysis within each step. Computer programs which have evolved from such consideration are discussed in [42, 63, 64, 65].

Considerations of post-buckling behavior and large deflections can be also evaluated using orthotropic plate analysis. Some behavior analysis of plates under combined lateral pressure and uniaxial edge compression is given in [2]. Design charts for stiffened and unstiffened plates, with and without initial deformation, subjected to uniaxial inplane load and lateral pressure are presented in [3]. For

*Some computations in reference [67] showed, as an example, for a deck gross panel of Mariner type vessels having a plate thickness of 1.125 inches and a frame spacing of 30 inches, the critical buckling load of plating between the stiffeners is equal to the yield stress while the critical buckling load of the gross panel as a whole with considerations of elastic restraint at the sides is only about 8,200 p.s.i. The latter value is lower than the expected compressive load resulting from the maximum sagging moment.

stiffened and unstiffened plates, subjected to biaxial edge compression and lateral loads, charts are presented in reference [14] for calculating the effective width, center deflection, buckling loads and bending stresses in the post-buckling range. Examples showing the application of such charts are also given in [14]. Additional analysis and examples of application are given by Schultz in [66].

In examining the finite element method, the orthotropic plate analysis, and the grillage analysis in the non-linear large-deflection range of gross panels under biaxial compression and lateral loads, it was hoped to conclude that one or the other method is consistently more reliable and adequate in all situations. Unfortunately, no such statements can be made with a high degree of certainty since the amount of available evidence is not substantial enough to support such a statement. Each method has its own limitation as discussed in Section 3 of this report. The finite element method provides a more accurate geometric representation of the gross panel. The effort and time involved in the application, however, is much larger than the other methods.

(3) Ultimate Strength and Failure Modes

In the ultimate strength analysis it is desirable and convenient to distinguish between two cases as discussed in Section 3. The distinction between the two cases depends on the relative magnitude and dominance of the inplane loads. Such distinction is justified since the basic concepts and methods of approach are quite different in the two cases as indicated below.

(a) Small inplane loads: If the inplane loads are small compared to their critical values (about 60% of their critical values), the limit and shakedown analyses provide adequate approach for estimating the collapse lateral load and the ultimate strength of the gross panels subject to the limitations discussed in Section 3. Typically in the limit analysis of grillages the elementary collapse mechanism or the combination of elementary collapse mechanisms which give the smallest ultimate load is the mechanism in which the panel will collapse. This requires the consideration and evaluation of several collapse mechanisms. A simplified method, however, has been extended to include biaxial loading condition as discussed in Section 3-B. The governing equations (equation 23 to 34) presented and applied to three grillages in the same section can be used for estimating the collapse load under these loading conditions.

(b) Dominant inplane loads: If the inplane loads are large, the adequacy of existing methods of predicting the ultimate collapse load depends on the particular mode of failure. Some experience has been gained in certain modes of failure and, correspondingly, some expressions have evolved. In some other modes of failure, however, the progress has been slow and either no well established reliable procedure is available, or in some cases, no clear measure of the relative reliability between the available procedures can be affirmed. In general, if the collapse of the gross panel under biaxial compression and lateral pressure occurs by coupling of more than one mode of failure, it is fair to state that no procedure is available at the present time with a firm evidence of providing the correct solution under all physical circumstances.

Some of the available expressions and procedures for the individual failure modes are presented below. Recommending these expressions and procedures

neither necessarily means that they can be applied with absolute confidence nor that they are reliable in all situations. It only means that they are the most suitable and promising existing methods.

(i) Failure of Plating Between Stiffeners

This mode of gross panel failure becomes particularly important in transversely framed ships, especially in deck platings near hatch openings. Provided that the slenderness ratio of the plate is large (see Section 2), it is well known that plates, unlike beams, can carry loads beyond the critical buckling load. The ultimate compressive load can be determined in this case using von Kármán's concept which states that the load-carrying capacity of the plate is exhausted when the edge stress approaches the yield point. Such considerations lead to the following expression for a simply supported plate subjected to uniaxial compression [55].

$$P_{ult} = 2ch\sigma_{yp} = \frac{\pi h^2}{\sqrt{3(1-\nu^2)}} \sqrt{E \sigma_{yp}} \quad (54)$$

where σ_{yp} is the yield stress of the material, "h" is the plate thickness and "2c" is the effective width of plating, given in this case by:

$$2c = \frac{\pi h}{\sqrt{3(1-\nu^2)}} \sqrt{\frac{E}{\sigma_{yp}}} \quad (55)$$

Experiments are in satisfactory agreement with equation (54), (see reference 55). A better agreement can be obtained by using in equation (55), instead of the constant factor $\frac{\pi}{\sqrt{3(1-\nu^2)}} = 1.9$ (for $\nu = 0.3$) a factor K varying with the non-dimensional parameter $\sqrt{\frac{E}{\sigma_{yp}}} \cdot \frac{h}{b}$. Reference [55] gives the experimental values of the factor K which decreases with increasing values of this parameter.

For wide ship plating subjected to uniaxial compression only, analytical values of the effective width "2c" can be obtained from curves presented in [67]. When biaxial loading condition exists, the effective width can be determined from the charts presented in [14] and can be used in conjunction with equation (54).

If the edges of the plate are kept straight during buckling and assuming that failure of the plate occurs when the maximum shear stress reaches a value equal to $\frac{1}{2} \sigma_{yp}$, the following expression for the ultimate load is given by

Timoshenko [55] for a simply supported square plate under uniaxial compression:

$$P_{ult} = 2ah \sigma_{yp} \left(0.434 + 0.566 \frac{\sigma_{cr}}{\sigma_{yp}} \right) \quad (56)$$

where a is the plate length and σ_{cr} is the critical buckling stress. Comparisons between results of equations (54) and (56) together with test data are given in reference [55]. The straight-edge condition seems to be more representative of plating between stiffeners in ship gross panels.

The effect of the lateral pressure is unlikely to cause significant loss in the plating compressive strength, particularly if the ultimate compressive loads are much larger than their critical buckling value. Charts presented in [3] and [14] show clearly such trends. Experimental data confirmed this conclusion [50, 68]. Charts presented in [14] show also that a small inplane load in the transverse direction has little effect on the effective width, particularly if the inplane load in the longitudinal direction is much larger than the critical buckling value. Reference [3] shows the effect of initial deflection on the effective width for plates under lateral and uniaxial loads. In general, the effect of the initial deflection is to decrease the effective width but such effects become less pronounced as the inplane load becomes larger than its critical value.

Becker and Calao [62] presented an interesting semi-empirical approach to the determination of the ultimate strength under biaxial loading conditions. In their approach the uniaxial strength data are utilized together with interaction relations between the inplane stresses. To apply the procedure properly for the biaxial strength prediction it is necessary to have a complete background of data on the uniaxial strength. The experimental comparison with this approach [62] is favorable.

(ii) Flexural Buckling of Longitudinal Stiffeners

In this mode of failure, the ultimate load carrying capacity of the gross panel is governed by column-like flexural buckling of the longitudinal stiffeners (together with the effective breadth of plating) between the transverse stiffeners. If buckling is assumed to be purely flexural and under uniaxial and lateral loading condition elasto-plastic finite element programs [42, 50] can be useful in this regard. Alternatively, grillage representation and beam-column elasto-plastic behavior such as adopted by Kondo [34] and Rutledge and Ostapenko [35] can be used. Development of parametric studies, design charts, and simplified design methods based on these approaches can be very useful for the usual design work. For large values of b/h and under lateral pressure combined with uniaxial load only Vojta and Ostapenko [69] presented such design nomographs.

In reference [46] Stavovy presents a simplified practical formulation for the longitudinally stiffened panel (between transverse stiffeners) subjected to edge compression only which can be easily used in design. Unfortunately no similar formula exists for the case of biaxial inplane loads combined with lateral pressure.

(iii) Tripping of Longitudinal Stiffeners

This mode of failure is usually a result of coupled flexural and torsional modes of buckling. Some elastic buckling expressions obtained by Bleich were presented in Section 4-A of this report; however, no satisfactory method seems

to exist for the inelastic tripping of stiffeners welded to continuous plating and for the prediction of the inelastic collapse strength. A detailed discussion of this mode of failure is given in [50].

(iv) Overall Gross Panel Buckling

As was mentioned earlier in Section 4-B, slender gross panels have a certain amount of post-buckling reserve, i.e., the buckling loads as given in Section 4-A under "overall grillage buckling" can be exceeded by a certain amount without danger to the structure. In a biaxial loading condition combined with lateral pressure very few procedures are available for predicting the ultimate strength of such gross panels.

Assuming that von Kármán's effective width concept holds in a similar manner to that in the unstiffened plates, the design charts presented in reference [14] can be used in an iterative manner to determine the effective width of the gross panel and its ultimate strength. The effective width can be determined from these charts for a variety of biaxial loading combinations together with lateral pressure. The charts indicate, however, that the ultimate strength is very little affected by the magnitude of the lateral load particularly if the edge loads are much larger than the critical buckling load. This observation is in agreement with recent experimental results given in [50]. Also, according to these charts an inplane load in the transverse direction has a small effect in the effective width if the inplane load in the longitudinal direction is much larger than the critical value. No experimental confirmation, however, exists of this latter observation.

The ultimate gross panel strength in this mode of failure can also be predicted using expressions given by Faulkner [31] if biaxial loading conditions exist but without lateral pressure. In his approach, Faulkner used a discrete beam solution for gross panels with sides and ends elastically restrained against rotation. The general biaxial elastic buckling solution given by equations (12) and (13) of reference [31] may be used in conjunction with equations (33) and (34) of that report to allow for the inelastic effects using the tangent modulus concept. No allowance is made, however, in this approach to the non-linear large deformations which make it more suitable for application to gross panels with heavy stiffeners.

If only uniaxial inplane load is present in conjunction with lateral pressure, the method presented by Parsanejad and Ostapenko in reference [36] and discussed in Section 3 of this report can be used for estimating the gross panel ultimate strength. No design information for manual calculation is, however, presented in the report [36].

Each of the three methods discussed above for predicting the overall grillage mode of failure is suitable under a specific loading combination and geometric characteristics. A need clearly exists for test data to evaluate these methods and probably for further development of the underlying theory.

C. Test Program

It has been pointed out under "A" and "B" of this section that, in many instances, the recommended expressions and procedures for estimating the behavior, the critical buckling loads, the failure mechanisms and the collapse loads of ship gross panels still are far from being completely well-established and reliable in all physical situations, particularly if a biaxial loading condition exists in combination with lateral pressure. It was also pointed out that in some cases no clear measure of the relative reliability between the available procedures can be ascertained and a firm evidence of the "exact" solution is not available. Although test programs may not provide the ultimate answer to all the questions discussed in the preceding sections, a well-developed program will, undoubtedly, provide some insight into the problem and a possible measure of the relative reliability of the recommended formulas and procedures. It is also envisioned that such a test program will enhance and contribute to the progress of the underlying theories and analytical procedures. At the same time, improvement of existing empirical formulas and development of new ones may evolve from the existing experimental data together with the developed results. The need for such a test program has been pointed out in many references [46, 9, 14, 50, 62], particularly for biaxial loading conditions combined with lateral pressure.

The test program should be directed mainly towards fulfilling two objectives:

- (1) Verifying and calibrating* methods for predicting the non-linear behavior of gross panels and estimating their collapse loads and mechanisms. For the latter purpose at least one gross panel should be designed in each of the collapse modes discussed earlier. A direct comparison can be then made between experimental results and the recommended analytical expressions and procedures as given under "A" and "B" of this section, and others if found suitable.
- (2) Examining grillages of dimensions and stiffness characteristics similar to those existing in ships, thus testing the likelihood of the different failure modes and the corresponding ultimate load carrying capacity in actual ship structures.

The above objectives can be accomplished through a two-phase test program.

Phase I

This phase should be concerned primarily with fulfilling the elements of objective (1) above. Gross panel models of scale approximately 1/4 or 1/5 should be suitable in this regard. The plate thickness should be of the order of 0.10 in. to 0.20 in. Several stiffeners in each direction should be used and end-bays should be reinforced to avoid premature failure in these regions. A high quality of fabrication and manufacture with minimum welding distortions should be sought. The initial deformations and distortions should be thoroughly measured and recorded before testing, particularly the profile of the platings between stiffeners. The material properties from which the gross panel models are manufactured should be determined by compression as well as tensile tests. The loading conditions on the models should consist of:

*Analytical methods can be calibrated using test results in order to develop semi-empirical formulations.

- (i) Lateral pressure and uniaxial edge compression.
- (ii) Lateral pressure and biaxial edge compression.
- (iii) Biaxial edge compression.

In the biaxial compression tests (ii) and (iii) the transverse edge compression should be of the order of magnitude of 20% to 40% of the longitudinal edge compression.

The models should be loaded first elastically then into the elastic-plastic region and finally to the plastic collapse. Measurements of deflections and strains at selected locations in the plating between stiffeners and at the stiffeners should be taken with the objective of verifying the recommended analytical expressions given under "A" and "B" and others if found suitable. Whenever possible, the boundary conditions used in the derivation of the analytical expressions should be adopted in the test program. Alternatively, if this causes experimental difficulties, the analytical formulas should be rederived to correspond to the experimental boundary conditions of the gross panel. The behavior of the gross panel is indeed sensitive to the boundary conditions and the reliability of the correlation depends to a large extent on achieving a one-to-one correspondence in boundary conditions between the test and the analysis.

Several gross panel models should be designed and tested. At least one should be designed to fail in each of the collapse modes discussed earlier. In this regard the proportions of the lateral pressure to the edge compression should be varied so that the distinction between lateral pressure collapse mechanisms and the ultimate compressive load mechanisms can be made and correlated with the corresponding analytical expressions. The stages of development of each mechanism should be observed and recorded.

An important part in fulfilling this phase objective is the subsequent analysis of the test data and correlation with the analytical expressions and procedures. Calibration of such analytical expressions should be made whenever necessary with an objective of developing semi-empirical formulas. The effect of a transverse compression of the order of 20% to 40% of the longitudinal compression on the behavior and ultimate strengths of the models should be investigated from the resulting experimental data.

The initial experimental work sponsored by the Ship Structure Committee [49, 68] fits and contributes to this phase.

Phase II

This is envisioned as a long-term phase which involves expensive experiments on full-scale ship gross panels and is concerned mainly with satisfying objective (2) stated above as a final goal. The details of this phase cannot be completely outlined without examining the results of Phase I, or, at least a considerable part of them. For example, whether or not a biaxial loading condition should be incorporated in this phase testing program is dependent primarily on its effect

on the gross panel behavior resulting from Phase I model experiments. However, some general needs which actually complement Phase I program can be identified at the present time. These are:

- (i) Examination of the effect of the residual stresses and weld-induced distortions and strains in actual full scale gross panels. This will require measurements of residual stresses in the stiffeners and the platings.
- (ii) Identification of the likelihood of the different failure modes and the corresponding ultimate loads of the full scale gross panels.
- (iii) Further verification or modification of the analytical or empirical expressions determined in Phase I.

It is envisioned that the extensive (but less expensive) test program of Phase I would reduce the necessary testing in Phase II and the corresponding cost to a reasonable limit.

5. GENERAL REMARKS

- A. Based on the analyses of the possible failure modes and the diversity of failure mechanisms it is clear that, at the present time, there exists no general theory which allows for the prediction and identification of all possible failure modes under different loading combinations and different geometric characteristics of the plate-stiffener combination. Such theory, if and when developed, would likely be too complicated for practical application and design work. Nor does there exist a reliable method for estimating the gross panel collapse strength under biaxial and lateral loading conditions when the collapse mechanism involves coupling between several modes of failure. Some methods exist, however, which can be used to estimate the buckling and ultimate collapse loads under some uncoupled modes of failure as discussed in Section 4. In all cases, premature failure of a local character such as weld and joint weakness is assumed not to occur.
- B. The available methods for estimating gross panel strength do not allow for cumulative damage by fatigue and brittle fracture. When conditions are conducive to such kinds of failure separate analyses must be conducted.
- C. Because of the limitations on the control of the properties of steel, and the limitations on fabrication of ship components, certain variability will arise in the actual strength of apparently identical gross panels. Uncertainties associated with the plate and stiffener rigidities and dimensions, yield strength of the material, residual stresses, plate fairness, manufacturing imperfections, etc. will contribute to such variability. This points toward the need for statistical data collection (full scale and model) and probabilistic methods of analysis.
- D. Existing experimental data on gross panel strength should be compiled, classified and stored in data banks as an important step in the recommended test program. Such data should be analyzed and used in conjunction with the new test data to verify the analytical methods and modify or develop semi-analytical or empirical formulations as discussed in Section 4. Dissemination of these data would also contribute to new developments in theory.
- E. In spite of the difficulties discussed above, the knowledge of the ultimate load carrying capacity of ship gross panels is important. As indicated in reference [53]: "Its value lies not so much in the fact that it might lead to economies in structural weight and perhaps cost, but more in the realism that knowledge of the limiting conditions, beyond which a structure will fail to perform its function, is an essential part of a rational design process."

ACKNOWLEDGEMENT

The author is grateful to the Ship Structure Committee for supporting this project and to the program advisory committee for their discussion. The author wishes also to acknowledge the assistance and contributions of the following individuals: Messrs. Y. H. Chen, D. Hiller, and J. Pique Del Pozo. Sincere thanks are expressed to Ms. S. Monrad for work on the manuscript.

REFERENCES

- [1] Von Kármán, Th., "Festigkeitsprobleme im Maschinenbau." Encyklopädie der Mathematischen Wissenschaften, Vol. 4, 1910.
- [2] Mansour, A., "On the Nonlinear Theory of Orthotropic Plates." Journal of Ship Research, p. 266, December, 1971.
- [3] Mansour, A., "Postbuckling Behavior of Stiffened Plates with Small Initial Curvature under Combined Loads." International Shipbuilding Progress, June, 1971.
- [4] Schade, H. A., "Bending Theory of Ship Bottom Structures." Trans. SNAME, Vol. 46, p. 176, 1938.
- [5] Schade, H. A., "The Orthogonally Stiffened Plate under Uniform Lateral Load." Journal of Applied Mechanics, p. A-143, December, 1940.
- [6] Schultz, H.-G., "Zum Stabilitätsproblem elastisch eingespannter orthotroper Platten." Schiff und Hafen, Heft 6, 1962.
- [7] Mansour, A., "Ship Bottom Structure under Uniform Lateral and Inplane Loads." Schiff und Hafen, Heft 5, 1967.
- [8] Smith, C. S. and Faulkner, D., "Dynamic Behavior of Partially Constrained Ship Grillages." The Shock and Vibration Bulletin, No. 40, Part 7, NRL, Washington, D.C., December, 1969.
- [9] Røren, E. M. Q. and Hansen, H. R., "Buckling Design in Ship Structures." Det Norske Veritas, Publication No. 89, Aug., 1975.
- [10] Soper, W. G., "Large Deflection of Stiffened Plates." Trans. of the ASME, December, 1958.
- [11] Ames, F., "Buckling and Postbuckling Behavior of a Large Aspect Ratio Orthotropic Plate under Combined Loadings." Thesis for Ocean Engineer degree and M.S. in Mech. Eng., MIT, May, 1973.
- [12] Ando, N., "On the Strength of Orthogonally Stiffened Plates." Technical Research Institute, Reports No. 48 and 53, 1962.
- [13] Ames, F. and Mansour, A., "Behavior of Orthotropic Plates." Proceedings of the Seventh Southeastern Conference on Theoretical and Applied Mechanics, Vol. 7, Catholic University of America, Washington, D.C., March 21-22, 1974.
- [14] Mansour, A., "Charts for the Buckling and Post-buckling Analysis of Stiffened Plates Under Combined Loading." Technical and Research Bulletin No. 2-22, Society of Naval Architects and Marine Engineers, July, 1976.
- [15] Smith, C., "Elastic Buckling and Beam-Column Behavior of Ship Grillages." Trans., RINA, 1967.

REFERENCES (CONT'D)

- [16] Peterson, F., Johnson, E. S., and Jacobs, E. N., "Orthogonally Stiffened Plates." Final Report under Navy Contract N6-ONR-25113, NR-035-258, Stanford University, Stanford, California, 1949.
- [17] Chin, K. D., "Stability of Orthotropic Stiffened Composite Plates." Journal of the Engineering Mechanics Division, ASCE, Vol. 98, October, 1972.
- [18] Drucker, D. C., Greenberg, H. J., and Prager, W., "Extended Limit Design Theorems for Continuous Media." Quarterly of Applied Mathematics, Vol. 9, January, 1952.
- [19] Greenberg, H. J. and Prager, W., "Limit Design of Beams and Frames." Trans. ASCE, Vol. 117, 1952.
- [20] Bleich, H., "Über die Bemessung Statisch unbestimmter Stahltragwerke unter Berücksichtigung des elastisch plastischen Verhaltens des Baustoffes." Bauingenieur, Vol. 13, 1932.
- [21] Symonds, P. S. and Prager, W., "Elastic-Plastic Analysis of Structures Subjected to Loads Varying Arbitrarily between Prescribed Limits." Journal of Applied Mechanics, Trans. ASME, Vol. 72, 1950.
- [22] Koiter, W. T., "A New General Theorem on Shakedown of Elastic-Plastic Structures." Proceedings Koninklijke Nederlandsche Academie van Wetenschappen, Series B, Vol. 59, 1956.
- [23] Mansour, A. and Jones, N., "Elastic and Plastic Analysis of a Tanker Web Frame." Journal of Ship Research, Vol. 17, No. 3, 1973.
- [24] Boufounos, T., "Plastic Shakedown Behavior of Ship Frames and Panels." Thesis submitted in the partial fulfillment of the requirements for the degree of Doctor of Science, Dept. of Ocean Engineering, MIT, 1975.
- [25] Heyman, J., "The Plastic Design of Grillages." Engineering, Vol. 176, 1953.
- [26] Heyman, J., "The Limit Design of a Transversely Loaded Square Grid." Journal of Applied Mechanics, Vol. 19, 1952.
- [27] Chang, P.-Y., "A Simple Method for Elastic Analysis of Grillages." Journal of Ship Research, June, 1968.
- [28] Nielsen, R., Chang, P.-Y., and Deschamps, L., "A Simple Approach to the Strength Analysis of Tankers." Trans. SNAME, 1971.
- [29] Adamchak, J., "A Rapid Technique for Predicting the General Instability of Ship Grillages with Elastically Constrained Edges." NSRDC Report No. 4604, February, 1975.
- [30] Davison, L. and Hughes, O., "A Simplified Method of Grillages Analysis." The University of New South Wales, School of Mechanical and Industrial Engineering, May, 1974.

REFERENCES (CONT'D)

- [31] Faulkner, D., "The Overall Compression Buckling of Partially Constrained Ship Grillages." MIT Sea Grant Project, Report. No. MITSG 73-10 (10 May 1973).
- [32] Faulkner, D., "Compression Strength of Welded Grillages." Chapter 21 of Ship Structural Design Concepts, edited by H. Evans, SSC, 1974.
- [33] Faulkner, D., Adamchak, J. G., Snyder, G. J., and Vetter, M. F., "Synthesis of Welded Grillages to Withstand Compression and Normal Loads." Proc. of the National Symposium, Computerized Structural Analysis and Design, George Washington University, Washington, D.C., March, 1972; Journal of Computers and Structures, Vol. 3, 1973, pp. 221-246.
- [34] Kondo, J., "Ultimate Strength of Longitudinally Stiffened Plate Panels Subjected to Combined Axial and Lateral Loading." Fritz Laboratory Report No. 248.13, Lehigh University, August, 1965.
- [35] Rutledge, D. R. and Ostapenko, A., "Ultimate Strength of Longitudinally Stiffened Plate Panels." Fritz Engineering Laboratory, Report No. 248.24, Lehigh University, September, 1968.
- [36] Parsanejad, S. and Ostapenko, A., "Ultimate Strength Analysis of Plate Grillages Under Combined Loads." Fritz Engineering Laboratory, Report No. 323.11, September, 1972.
- [37] Gallagher, R., "The Finite Element Method in the Elastic Instability Analysis." Paper prepared under NASA Grant NGR 33-010-070, Cornell University.
- [38] Paulling, J. R., "The Analysis of Complex Ship Structures by the Finite Element Technique." Journal of Ship Research, Vol. 8, No. 3, December, 1964.
- [39] DAISY/MASKA Programming Manual, by H. A. Kamel; the University of Arizona, 1968.
- [40] Kavlie, D. and Clough, R., "A Computer Program for the Analysis of Stiffened Plates under Combined Inplane and Lateral Loads." Report No. UCSESM 71-4, Structural Engineering Laboratory, University of California, Berkeley, 1971.
- [41] Pifko, A. and Isakson, G., "A Finite Element Method for the Plastic Buckling of Plates." AIAA Journal, Vol. 7, No. 10, 1969.
- [42] Terazawa, K., et al., "Analysis of Elastic-Plastic Buckling of Plates with Stiffeners by Finite Element Method." Selected papers from the Journal of the Society of Naval Architects of Japan, Vol. 127, 1970.

REFERENCES (CONT'D)

- [43] Aamodt, B. and Mo., O., "Elasto-Plastic Analysis Using an Efficient Formulation of the Finite Element Method." Det norske Veritas, publication No. 92, February, 1976.
- [44] Soreide, T., et al., "Ultimate Collapse Behavior of Stiffened Plates Using Different Finite Element Approaches." Paper presented at the International Conference on Steel Plated Structures, Imperial College, London, July, 1976.
- [45] Crisfield, M. and Puthli, R., "A Finite Element Method Applied to the Collapse Analysis of Stiffened Box Girder Diaphragms." Paper presented at International Conference on Steel Plated Structures, Imperial College, London, July, 1976.
- [46] Stavovy, A. B., "Ultimate Longitudinal Strength of Ships." NSRDC Report No. 3270, January, 1970.
- [47] "ICES-STRU DL II" Integrated Civil Engineering System-Structural Design Language, MIT, Cambridge, Report R70-77, Vol. 2, June, 1971.
- [48] "SOLID SAP" Structural Analysis Program for Static Response of Linear Systems, College of Engineering, University of California, Berkeley, California.
- [49] Becker, H., Colao, A., Goldman, R., and Pazerycki, J., "Compressive Strength of Ship Hull Girders, Part II-Stiffened Plates." Ship Structure Committee Report No. SSC-223, 1971.
- [50] Smith, C. S., "Compressive Strength of Welded Steel Ship Grillages." RINA Spring Meeting, 1975.
- [51] Correspondence with D. Faulkner, Dept. of Naval Architecture and Ocean Engineering, University of Glasgow, Scotland, September 11, 1975 and October 27, 1975.
- [52] Correspondence with C. S. Smith, Naval Construction Research Establishment, Dunfermline, Fife, Scotland, September 11, 1975 and September 18, 1975.
- [53] "Plastic and Limit Design." International Ship Structures Congress, Report of Committee No. 3e, 1967.
- [54] Bleich, F., Buckling Strength of Metal Structures. McGraw-Hill Book Co., New York, 1952.
- [55] Timoshenko, S. and Gere, J., Theory of Elastic Stability. McGraw-Hill Book Company, New York, 1961.
- [56] Bleich, F. and Ramsey, L., "A Design Manual on the Buckling Strength of Metal Structures." SNAME Technical and Research Bulletin No. 2-2.
- [57] Smith, C. "Bending, Buckling and Vibration of Orthotropic Plate-Beam Structures." Journal of Ship Research, Vol. 12, No. 4, 1968.

REFERENCES (CONT'D)

- [58] Mansour, A., "Orthotropic Bending of Ship Hull Bottom Plating Under the Combined Action of Lateral and Inplane Loads." Published for MARAD as report No. NA-66-2, Contract No. NA 2620, University of California, College of Engineering, Berkeley, 1966.
- [59] Wah, T., editor, "A Guide for the Analysis of Ship Structures." Dept. of Commerce, Office of Technical Services, Washington, D.C., 1960.
- [60] Hiller, D., "Buckling Loads of Simply Supported Rectangular Orthotropic Plates Compressed in Two Inplane Perpendicular Directions." Master Thesis, University of California, Berkeley, June, 1976.
- [61] Ramberg, W. and Osgood, W., "Description of Stress-Strain Curves by Three Parameters." NACA, T.N. 902, July, 1943.
- [62] Becker, H. and Colao, A., "Compressive Strength of Ship Hull Girders-Part III Theory and Additional Experiments." Ship Structure Committee Report No. SSC-267, 1977.
- [63] Pifko, A., Levine H., and Armen, H., "PLANS-A Finite Element Program for the Non-Linear Analysis of Structures." Grumman Aerospace Corporation, Report No. RE-501, 1974.
- [64] Martin, H., "Finite Element Formulations of Geometrically Non-linear Problems." Eds., H. Gallagher, Y. Yamada, and J. T. Oden, Proc. 1st U.S. - Japan Seminar Matrix Methods in Structural Mechanics and Design, UAH press, University of Alabama, Huntsville, Alabama, 1970.
- [65] MacNeal R. H. and McCormick, C. W., "The NASTRAN Computer Program for Structural Analysis." Computers and Structures, Vol. 1, Pergamon Press, 1971.
- [66] Schultz, H.-G., "Zur Tragfähigkeit Druckbeanspruchter Orthotroper Platten." Jahrbuch der Schiffbautechnischen Gesellschaft, Band 56, 1962, p. 182.
- [67] Schultz, H.-G., "Recent Development in Ship Hull Girder Investigations." Paper presented at the Northern California Section of SNAME, San Francisco, March, 1964.
- [68] Becker, H., Goldman, R., and Pazerycki, J., "Compressive Strength of Ship Hull Girders-Part I, Unstiffened Plates." Ship Structure Committee Report No. SSC-217, 1970.
- [69] Vojta, J. F. and Ostapenko, A., "Ultimate Strength Design Curves for Longitudinally Stiffened Plate Panels with Large "b/t". Fritz Laboratory Report No. 248.19, Lehigh University, August, 1967.
- [70] Vasta, John, "Structural Tests on the Liberty Ship S.S. Philip Schuyler." Trans. SNAME, 1947.

APPENDIX I

BIBLIOGRAPHY

Gross Panel Strength Study SR-225

I. GENERAL

- (1) Abrahamsen, E., "Orthogonally Stiffened Plate Fields." Review prepared for the first I.S.S. Congress in Glasgow, 1961.
- (2) Ahmed, M. H. S., "Buckling of Transverse Framed Decks in Ship Structures by Edge Compressive Loading." Int. Shipbuilding Progress, Vol. 12, November 1965, p. 421.
- (3) Ando, N., "On the Strength of Orthogonally Stiffened Plates." Transp. Tech. Res. Inst., Report Nos. 48 and 53, 1962.
- (4) Becker, H., Colao, A., Goldman, R., and Pazerycki, J., "Compressive Strength of Ship Hull Girders, Part II, Stiffened Plates." SSC-223, 1971.
- (5) Bleich, F., Buckling Strength of Metal Structures. McGraw-Hill Book Company, Inc., New York, 1952.
- (6) Caldwell, J. B., "Ultimate Longitudinal Strength." Trans. RINA, Vol. 107, 1965, p. 411.
- (7) Clarkson, J., "A New Approach to the Design of Plates to Withstand Lateral Pressure." Quarterly, Trans. Inst. Nav. Arch., Vol. 98, No. 4, October, 1956.
- (8) Coan, J. M., "Large-deflection Theory for Plates with Small Initial Curvature Loaded in Edge Compression." Journal of Applied Mechanics, p. 143, June, 1951.
- (9) Conley, W. F., Becker, L. A., and Allnutt, R. B., "Buckling and Ultimate Strength of Plating Loaded in Edge Compression." DTMB Report 1419, April, 1960.
- (10) Davidson, H. L., "Post-Buckling Behavior of Long Rectangular Plates." FEL Report 248.15, Lehigh University, June, 1965.
- (11) Design Data Sheet DDS 2900-1, Naval Ship Engineering Center, Hyattsville, Md., Dec. 27, 1950.
- (12) Design Data Sheet DDS 9110-3.
- (13) Dwight, J. B., "Collapse of Steel Compression Panels." Developments in Bridge Design and Construction, Crosby Lockwood, 1971.
- (14) Dwight, J. B. and Moxham, K. E., "Welded Steel Plates in Compression." The Structural Engineer, Vol. 47, No. 2, February, 1969, pp. 49-66.

- (15) Dwight, J. B. and Ractliffé, A. T., "The Strength of Thin Plates in Compression." Int. Symposium on Thin-Walled Steel Structures (Swansea, 1967), London, Crosby Lockwood, 1969, pp. 3-34.
- (16) Evans, J. H., et al., "Ship Structural Design Concepts." SSC investigation SR-200, 1974.
- (17) Faulkner, D., "A Review of Effective Plating to be Used in the Analysis of Stiffened Plating in Bending and Compression." M.I.T. Dept. of Ocean Engineering, Sea Grant Report MIT SG-73-11.
- (18) Faulkner, D., Adamchak, J. G., Snyder, G. J., and Vetter, M. F., "Synthesis of Welded Grillages to Withstand Compression and Normal Loads." Proc. of the National Symposium, Computerized Structural Analysis and Design, George Washington University, Washington, D.C., March, 1972; Journal of Computers and Structures, Vol. 3, 1973, pp. 221-246.
- (19) Heller, S. R., "Capability of Ship Structure to Resist Loads." Naval Engineer's Journal, No. 2, April, 1974.
- (20) Kerfoot, R. P. and Ostapenko, A., "Grillages Under Normal and Axial Loads--Present Status." Fritz Engineering Laboratory Report 323.1, Lehigh University, June, 1967.
- (21) Levy, S., "Bending of Rectangular Plates with Large Deflections." NACA Report No. 737, 1942.
- (22) Mansour, A., "Postbuckling Behavior of Stiffened Plates with Small Initial Curvature under Combined Loads." ISP, June, 1971.
- (23) Mansour, A., "Probabilistic Design Concepts in Ship Structural Safety and Reliability." Annual Meeting SNAME, New York, November, 1972.
- (24) Mansour, A. E. and Faulkner, D., "On Applying the Statistical Approach to Extreme Sea Loads and Ship Hull Strength." R.I.N.A., London, November, 1973.
- (25) Palermo, P. M. and Bart, R., "Plastic Analysis of Circular Bulkhead Stiffening Systems." David Taylor Model Basin Report 1946, March, 1965.
- (26) Payer, H. G., "Notes on the Buckling and Postbuckling Behavior of Deep Web Frames." Marine Technology, July, 1972, p. 302.
- (27) Report of Committee 6 on "Plastic and Limit Analysis." Proc. of the Fourth ISSC, Tokyo, 1970; published by SNAJ, February, 1971.
- (28) Schultz, H.-G., "Buckling and Post Buckling Behaviour of a Transversely Stiffened Ship's Hull Model." J. Ship Research, Vol. 8, No. 2, September, 1964, p. 7.

- (29) Schultz, H.-G., "Postbuckling Behavior of Wide Ship Plating." Report No. NA-64-3, Dept. of Naval Architecture, University of California, Berkeley, February, 1964.
- (30) Thein Wah, "A Guide for the Analysis of Ship Structures." A Government Research Report, U.S. Department of Commerce, Washington, D.C.
- (31) Timoshenko, S., Theory of Elastic Stability. New York, N.Y., McGraw-Hill Book Company, Inc., 1936.
- (32) Timoshenko, S. and Wainowsky-Krieger, S., Theory of Plates and Shells. McGraw-Hill Book Company, Inc., New York, 1959, 2nd edition.
- (33) Von Kármán, Th., "Festigkeitsprobleme im Maschinenbau." Encyklopadie der Mathematischen Wissenschaften, Vol. 4, 1910.
- (34) Yamaki, N., "Postbuckling Behavior of Rectangular Plates with Small Initial Curvature Loaded in Edge Compression." Journal of Applied Mechanics, p. 407, September, 1959.

II. FINITE ELEMENT ANALYSIS OF STIFFENED PLATES

- (1) Araldsen, P. O. and Egeland, O., "General Description of SESAM-62, Super Element Structural Analysis (Program) Modules." European Shipbuilding No. 2 - 1971.
- (2) Argyris, J. H., Fried, I., and Scharpf, D. W., "The TUBA Family of Plate Elements for the Matrix Displacement Method." Aeronautical Journal, Vol. 72, No. 8, August, 1968.
- (3) Argyris, J. H. and Scharpf, D. W., "Static and Dynamic Analysis of Thin Elastic Shells of Arbitrary Geometry by the Matrix Displacement Method." Proc. of the AIAA Structural Dynamics Specialist Conf., New Orleans, La., April, 1969.
- (4) Broere, R., "Application de la Methode des Elements Finis a l'Etude du Flambement Elastique des Plaques Minces de Forme Quelconque." ATMA, 1972.
- (5) Bronlund, O. E., "Eigenvalues of Large Matrices." Proc. of ISD/ISSC Symposium on Finite Element Techniques, Stuttgart, W. Germany, June, 1969.
- (6) Clough, R. and Tocher, J., "Finite Element Stiffness Matrices for Analysis of Plate Bending." Proc. of the (First) Air Force Conference on Matrix Methods in Structural Mechanics, AFFDL TR 66-80, November, 1965.
- (7) Fujita, Y., et al., "Elastic-Plastic Buckling of Plates using the Finite Element Method, (2nd Report)." JSNA, Vol. 127, June, 1970.
- (8) Gallagher, R., Gellatly, R., Mallett, R., and Padlog, J., "A Discrete Element Procedure for Thin Shell Instability Analysis." AIAA Journal, Vol. 5, No. 2, February, 1967.
- (9) Gallagher, R. and Padlog, J., "Discrete Element Approach to Structural Instability Analysis." AIAA Journal, Vol. 1, No. 6, June, 1963.
- (10) Gallagher, R. H. and Yang, H., "Elastic Instability Predictions for Doubly Curved Shells." Proc. of the 2nd Air Force Conference on Matrix Methods in Structural Mechanics, Dayton, Ohio, October, 1968.
- (11) Gisvold, K. M. and Moe, J., "Buckling Analysis by Means of Non-Linear Programming." Int. J. for Numerical Methods in Eng., Vol. 2, 1970, pp. 353-361.
- (12) Higuchi, M. and Horioka, M., "Numerical Analysis of Elastic Buckling of Reinforced Rectangular Plate by Electric Computer (1st and 2nd and 3rd Report)." The Nippon Kokan Tech., Rev. No. 47, 1969; No. 48, 1970; No. 50, 1970.
- (13) Kapur, K. and Hartz, B., "Stability of Plates Using the Finite Element Method." Proc. ASCE, Journal of the Engineering Mechanics Div., Vol. 92, No. EM 2, April, 1966.

- (14) Moses, F. and Tonnessen, A., "Dynamic Programming for Computing Optimal Plate Dimensions in Some Ship Structures." *European Shipbuilding*, No. 4, 1967.
- (15) Murray, D. W. and Wilson, E. L., "Finite Element Large Deflection Analysis of Plates." *Proc. ASCE, Journal of the Engrg. Mech. Div.*, No. EM1, February, 1969.
- (16) Navaratna, D. R., Pian, T. H., and Witmer, E. A., "Stability Analysis of Shells of Revolution by the Finite-Element Method." *AIAA Journal*, Vol. 6, No. 2, February, 1968.
- (17) Nördstrom, L. "Numerical Calculation of the Critical Stress in Diagonally Stiffened Plates." (In Swedish) CTH Report, 1970.
- (18) Paulling, J. R., "The Analysis of Complex Ship Structures by the Finite Element Technique." *Journal of Ship Research*, Vol. 8, No. 3, December, 1964.
- (19) Pifko, A. and Isakson, G., "A Finite Method for the Plastic Buckling Analysis of Plates." *AIAA J*, Vol. 7, No. 10, October, 1969.
- (20) Schmit, L., Bogner, F., and Fox, R., "Finite Deflection Analysis Using Plate and Cylindrical Shell Discrete Elements." *AIAA Journal*, Vol. 6, No. 5, May, 1968.
- (21) Terazawa, K., et al., "Elastic-Plastic Buckling of Plates using the Finite Element Method (2nd Report)." *JSNA*, Vol. 127, June, 1970.
- (22) Terazawa, K. Ueda, Y., and Matsuishi, M., "Elastic-Plastic Buckling of Plates by Finite Element Method." Paper presented at the ASCE National Meeting, New Orleans, La., February, 1969. Meeting Preprint 845.
- (23) Wempner, G., Oden, J. T., and Kross, D., "Finite-Element Analysis of Thin Shells." *Proc. ASCE, Journal of the Struct., Div.*, Vol. 94, No. EM6, December, 1968.
- (24) Yagi, J., et al., "Elastic-Plastic Analysis of Steel Structures Using Finite Element Method, 4th Report: Elastic Large Deflection of Plates." *KSNA* Vol. 135, 1970.
- (25) Yoshida, K., "Buckling Analysis of Plate Structures by the Strip Elements." *JSNA*, Vol. 130, December, 1971.

III. ORTHOTROPIC PLATE ANALYSIS

- (1) Ames, F., "Buckling and Postbuckling Behavior of a Large Aspect Ratio Orthotropic Plate under Combined Loadings." Thesis for Ocean Engineer degree and M.S. in Mechn. Eng., M.I.T., May, 1973.
- (2) Ames, F. and Mansour, A., "Behavior of Orthotropic Plates." Proceedings of the Seventh Southeastern Conference on Theoretical and Applied Mechanics, Vol. 7, Catholic University of America, Washington, D.C., March 21-22, 1974.
- (3) Chin, K. D., "Stability of Orthotropic Stiffened Composite Plates." Journal of the Engineering Mechanics Division, ASCE, Vol. 98, October, 1972.
- (4) Hearmon, R. F. S., "The Frequency of Flexural Vibration of Rectangular Orthotropic Plates with Clamped Supported Edges." J. App. Mech., December, 1959, p. 537.
- (5) Huffington, N. J., "Theoretical Determination of Rigidity Properties of Orthogonally Stiffened Plates." Journal of Applied Mechanics, 1956, p. 15.
- (6) Lechnitzky, S. G., "Anisotropic Plates." 2nd ed., Moscow, 1957.
- (7) Mansour, A., "Charts for the Buckling and Post-buckling Analysis of Stiffened Plates Under Combined Loading." Technical and Research Bulletin No. 2-22, Society of Naval Architects and Marine Engineers, July, 1976.
- (8) Mansour, A., "On the Nonlinear Theory of Orthotropic Plates." Journal of Ship Research, December, 1971, p. 266.
- (9) Mansour, A., "Orthotropic Bending of Ship Hull Bottom Plating under the Combined Action of Lateral and Inplane Loads." Doctoral Dissertation, University of California, Berkeley, College of Engineering, 1966.
- (10) Mansour, A., "Ship Bottom Structure under Uniform Lateral and Inplane Loads." Schiff and Hafen, Heft 5, 1967.
- (11) Mansour, A. and Nagler, R., "Bending of Stiffened Plates under Combined Lateral and Inplane Loads." Offshore Technology Conference, OTC 1231, Houston, Texas, 1970.
- (12) Peterson, F., Johnson, E. S., and Jacobs, E. N., "Orthogonally Stiffened Plates." Final Report under Navy Contract N6-ONR-25113, NR-035-258, Stanford University, Stanford, California, 1949.
- (13) Schade, H. A., "Bending Theory of Ship Bottom Structures." Trans. SNAME, Vol. 46, p. 176, 1938.
- (14) Schade, H. A., "The Orthogonally Stiffened Plate under Uniform Lateral Load." Jour. of Applied Mechanics, p. A-143, December, 1940.

- (15) Schultz, H. G., "Zur Tragfähigkeit Druckbeanspruchter Orthotroper Platten." Jahrbuck der Schiffbautechnischen Gesellschaft, Band 56, 1962, p. 182.
- (16) Smith, C. S., "Bending, Buckling and Vibration of Orthotropic Plate-Beam Structures." J. Ship Research, December, 1968, p. 249.
- (17) Smith, C., "Elastic Buckling and Beam-Column Behavior of Ship Grillages." Trans., RINA, 1967.

IV. ENERGY METHODS

- (1) Bengston, H., "Ship Plating Under Compression and Hydrostatic Pressure." Trans. SNAME, Vol. 47, 1939.
- (2) Bleich, H., "Über die Bemessung Statisch unbestimmter Stahltragwerke unter Berücksichtigung des elastisch plastischen Verhaltens des Baustoffes." Bauingenieur, Vol. 13, 1932.
- (3) Boufounos, T., "Plastic Shakedown Behavior of Ship Frames and Panels." Thesis submitted in the partial fulfillment of the requirements for the degree of Doctor of Science, Dept. of Ocean Engineering, MIT, 1975.
- (4) Collier, J. S., "Ultimate Strength of Plating Loaded in Edge Compression Effect of Adjacent Panels." NSRDC T. Note, April, 1967.
- (5) Drucker, D. C., Greenberg, H. J., and Prager, W., "Extended Limit Design Theorems for Continuous Media." Quarterly of Applied Mathematics, Vol. 9, January, 1952.
- (6) Heyman, J., "The Limit Design of a Transversely Loaded Square Grid." Journal of Applied Mechanics, Vol.
- (7) Heyman, J., "The Plastic Design of Grillages." Engineering, Vol. 176, 1953.
- (8) Koiter, W. T., "A New General Theorem on Shakedown of Elastic-Plastic Structures." Proceedings Koninklijke Nederlandsche Academie van Wetenschappen, Series B, Vol. 59, 1956.
- (9) Koiter, W. T., "The Effective Width of Flat Plates for Various Longitudinal Edge Conditions at Loads Far Beyond Buckling Load." National Luchtvaart-laboratorium (Netherlands), Report S 287, 1943.
- (10) Mansour, A. and Jones, N., "Elastic and Plastic Analysis of a Tanker Web Frame." Journal of Ship Research, Vol. 17, No. 3, 1973.
- (11) Ractliffe, A. T., "The Strength of Plates in Compression." Cambridge Univ. Engineering Dept., Ph.D. Thesis, October, 1968.
- (12) Sherbourne, A. N., "Elastic-Plastic Behaviour of Mild Steel Plates in Compression." Cambridge Univ. Engineering Dept., Ph.D. Thesis, 1960.
- (13) Symonds, P. S. and Prager, W., "Elastic-Plastic Analysis of Structures Subjected to Loads Varying Arbitrarily between Prescribed Limits." Journal of Applied Mechanics, Trans. ASME, Vol. 72, 1950.

V. GRILLAGES AND INTERSECTING BEAMS

- (1) Adamchak, J., "A Rapid Technique for Predicting the General Instability of Ship Grillages with Elastically Constrained Edges." NSRDC Report No. 4604, February, 1975.
- (2) Bell, A. O., Viner, A. C., and Richardson, W. S., "Beam and Column Strength of Stiffened Plates." Trans. RINA, Vol. 105, 1963.
- (3) Chang, P.-Y., "A Simple Method for Elastic Analysis of Grillages." Journal of Ship Research, June, 1968.
- (4) Davison, L. and Hughes, O., "A Simplified Method of Grillages Analysis." The University of New South Wales, School of Mechanical and Industrial Engineering, May, 1974.
- (5) Dawson, R. G. and Walker, A. C., "A Proposed Method for the Design of Thin-Walled Beams Which Buckle Locally." The Structural Engineer, Vol. 50, No. 2, February, 1972, p. 95.
- (6) Faulkner, D., "On the Overall Compression Buckling of Partially Constrained Ship Grillages." M.I.T., Sea Grant Report No. MITSG 73-10, 1973.
- (7) Faulkner, D., Adamchak, J. G., Snyder, G. J., and Vetter, M. F., "Synthesis of Welded Grillages to Withstand Compression and Normal Loads." Proc. of the National Symposium, Computerized Structural Analysis and Design, George Washington University, Washington, D.C., March, 1972; Journal of Computers and Structures, Vol. 3, 1973, pp. 221-246.
- (8) Kondo, J., "Ultimate Strength of Longitudinally Stiffened Plate Panels Subjected to Combined Axial and Lateral Loading." Fritz Laboratory Report No. 248.13, Lehigh University, August, 1965.
- (9) Nielsen, R. Chang, P.-Y., and Deschamps, L., "A Simple Approach to the Strength Analysis of Tankers." Trans. SNAME, 1971.
- (10) Nishino, F., "Buckling Strength of Columns and Their Component Plates." FEL Report 290.10, Lehigh University, 1964.
- (11) Parsanejad, S. and Ostapenko, A., "Ultimate Strength Analysis of Plate Grillages Under Combined Loads." Fritz Engineering Laboratory, Report No. 323.11, September, 1972.
- (12) Rutledge, D. R. and Ostapenko, A., "Ultimate Strength of Longitudinally Stiffened Plate Panels." Fritz Engineering Laboratory, Report No. 248.24, Lehigh University, September, 1968.
- (13) Vojta, J. F. and Ostapenko, A., "Ultimate Strength Design of Longitudinally Stiffened Plate Panels with Large b/t." Fritz Engineering Laboratory Report 248-18, Lehigh University, August, 1967.

VI. EXPERIMENTS

- (1) Becker, H. and Colao, A., "Compressive Strength of Ship Hull Girder-Part III, Theory and Additional Experiments." Sanders Associates, Inc., May, 1974.
- (2) Becker, H., Colao, A., Goldman, R., and Pazerycki, J., "Compressive Strength of Ship Hull Girders-Part II, Stiffened Plates." Ship Structure Committee Report No. SSC-223, 1971.
- (3) Becker, H. Goldman, R., and Pazerycki, J., "Compressive Strength of Ship Hull Girders-Part I-Unstiffened Plates." Ship Structure Committee Report No. SSC-217, 1970.
- (4) Botman, M., "The Experimental Determination of the Effective Width of Flat Plates in the Elastic and Plastic Range (Part 2)." NLA, Amsterdam, Report S 438, 1954.
- (5) Card, J., "Experimental Determination of Stresses in a Ship's Bottom Structure." M.S. Thesis, Dept. of Ocean Eng., M.I.T., 1970.
- (6) Chang, C. C. and Conway, H. D., "The Marcus Method Applied to Solution of Uniformly Loaded and Clamped Rectangular Plates Subjected to Forces in Its Plane." Journal of Applied Mechanics, Vol. 19, No. 2, June, 1952.
- (7) Clarkson, J., "Test of Flat Plated Grillages under Uniform Pressure." Trans. RINA, Vol. 105, No. 4, 1963, pp. 467-484 (including discussion).
- (8) Clarkson, J., "The Strength of Approximately Flat Rectangular Plates under Lateral Pressure." Trans. North East Coast Inst. Eng. and Shipbuilders, Vol. 74, 1957.
- (9) Clarkson, J. and Wilson, L. B., "Tests on Three Flat Plated Grillages: Part IV Plastic Collapse." Naval Construction Research Establishment Report No. NCRE/R390D, Dunfermline, December, 1957.
- (10) Dwight, J. B. and Moxham, K. E., "Further Tests on Welded Steel Columns." CIRIA Research Report, 1971.
- (11) Massonet, C. and Maquoi, R., "New Theory and Tests on the Ultimate Strength of Stiffened Box Girders." Int. Conf. Steel Box Girder Bridges, 13-14 February, 1973, ICE, London.
- (12) Nishino, F., Ueda, Y., and Tall, L., "Experimental Investigation of the Buckling of Plates with Residual Stresses." Test methods for compression members, ASTM STP 419, 1967.
- (13) Peterson, F. F., Johnson, E. S., and Jacobs, E. N., "Orthogonally Stiffened Plates." Final Report under Navy Contract N6-ONR-25113, NR-035-258, Stanford University, Stanford, California, 1949.
- (14) Smith, C. S., "Compressive Strength of Welded Steel Ship Grillages." RINA Spring Meeting, 1975.

- (15) Soper, W. G., "Large Deflection of Stiffened Plates." Trans. ASME, December, 1958, p. 444.
- (16) Young, A. G., "Ship-Plating Subjected to Loads Both Normal to and in the Plane of the Plate." Trans. of the Institution of Naval Architects, Vol. 99, pp. 578-597, 1957.

APPENDIX II

CRITICAL BUCKLING LOADS AND THEIR APPLICATION TO SHIP
GROSS PANELS UNDER BIAXIAL LOADING CONDITION

A simple procedure using the energy method can be used to determine the buckling loads of an orthotropic plate compressed in two perpendicular directions. If the work done by the compressive inplane loads is less than the strain energy due to bending and twisting of the plate, then the initial equilibrium of the flat plate is stable. If the work done by the inplane loads on the plate is greater than the total strain energy, the equilibrium of the plate becomes unstable and buckling will occur in some mode. The critical values of the load at which transition occurs from the stable to the unstable condition can be thus determined by equating the work done by the inplane loads to the total strain energy. The work done "T" by the external loads is given by:

$$T = \frac{1}{2} \int_0^B \int_0^L \left[\bar{N}_x \left(\frac{\partial^2 w}{\partial x^2} \right) + \bar{N}_y \left(\frac{\partial^2 w}{\partial y^2} \right) \right] dx dy \quad (i)$$

where \bar{N}_x and \bar{N}_y are inplane compressive loads per unit length in the x- and y-directions, respectively.

The total strain energy U due to bending and twisting of the plate is given by:*

$$U = \frac{1}{2} \int_0^B \int_0^L \left\{ D_x \left[\left(\frac{\partial^2 w}{\partial x^2} \right)^2 + \nu_y \frac{\partial^2 w}{\partial x^2} \frac{\partial^2 w}{\partial y^2} \right] + D_y \left[\left(\frac{\partial^2 w}{\partial y^2} \right)^2 + \nu_x \frac{\partial^2 w}{\partial x^2} \frac{\partial^2 w}{\partial y^2} \right] + 2D_{xy} \left(\frac{\partial^2 w}{\partial x \partial y} \right)^2 - 2D_x \nu_y \left(\frac{\partial^2 w}{\partial x \partial y} \right)^2 \right\} dx dy \quad (ii)$$

For a simply supported rectangular plate the deflection surface w can be expressed by:

$$w = \sum_{m=1}^{\infty} \sum_{n=1}^{\infty} a_{mn} \sin \frac{m\pi x}{L} \sin \frac{n\pi y}{B} \quad (iii)$$

*Notice that $D_x \nu_y = D_y \nu_x$

Equating the total strain energy U to the work done T and substituting the expression for w , the following expression results after carrying the required differentiation and integration and utilizing the orthogonality properties of the trigonometric functions.

$$\bar{N}_x \frac{m^2 \pi^2}{L^2} + \bar{N}_y \frac{n^2 \pi^2}{B^2} = D_x \frac{m^4 \pi^4}{L^4} + 2D_{xy} \frac{m^2 \pi^2}{L^2} \frac{n^2 \pi^2}{B^2} + D_y \frac{n^4 \pi^4}{B^4}$$

Multiplying both sides of the above equation by $\frac{L^2 B^2}{\sqrt{D_x D_y}}$ and using the notation:

$$\rho = \frac{L}{B} \sqrt[4]{\frac{D_y}{D_x}} \quad ; \quad \eta = \frac{D_{xy}}{\sqrt{D_x D_y}}$$

$$\bar{N}_x^* = \frac{\pi^2 \sqrt{D_x D_y}}{B^2} \quad ; \quad \bar{N}_y^* = \frac{\pi^2 \sqrt{D_x D_y}}{L^2}$$

one obtains,

$$\frac{\bar{N}_x}{\bar{N}_x^*} m^2 + \frac{\bar{N}_y}{\bar{N}_y^*} n^2 = \frac{m^4}{\rho^2} + 2 \eta m^2 n^2 + \rho^2 n^4 \quad (iv)$$

Using the average cross sectional areas per unit width h_x and h_y in the x- and y-directions, respectively, we get:

$$\frac{\sigma_x}{\sigma_x^*} m^2 + \frac{\sigma_y}{\sigma_y^*} n^2 = \frac{m^4}{\rho^2} + 2 \eta m^2 n^2 + \rho^2 n^4 \quad (v)$$

where

$$\sigma_x^* = \frac{\pi^2 \sqrt{D_x D_y}}{h_x B^2} = \frac{\bar{N}_x^*}{h_x} \quad ; \quad \sigma_y^* = \frac{\pi^2 \sqrt{D_x D_y}}{h_y L^2} = \frac{\bar{N}_y^*}{h_y}$$

$$\sigma_x = \frac{\bar{N}_x}{h_x} \quad ; \quad \sigma_y = \frac{\bar{N}_y}{h_y}$$

Equation (V) is the same as equation (50).

APPLICATION

Example 1:

Consider a gross panel in the bottom structure of a 70,000 DWT tanker bounded transversely and longitudinally by the transverse and longitudinal bulkheads, respectively. Figure 16 shows the gross panel overall dimensions and typical cross sections of the stiffeners. The rigidity coefficients of the gross panel were determined according to reference [2]. The following values were obtained [60].

$$D_x = 8.104 \times 10^{10} \text{ lb-in}$$

$$D_y = 1.653 \times 10^{10} \text{ lb-in}$$

$$\rho = \frac{98.75}{44.33} \sqrt[4]{\frac{1.653}{8.104}} = 1.5$$

$$\eta = 0.617$$

If an LBP/20" wave is used, the resulting full load draft yields approximately a transverse load $\bar{N}_y = 10,554 \text{ lb/in}$ and a longitudinal hogging bending moment of 1,207,453 ft-ton. The latter value yields an inplane compressive load on the gross panel $\bar{N}_x = 34,070 \text{ lb/in}$. Thus, typically, the transverse inplane compression is about 30% of the longitudinal compression.

$$\bar{N}_x^* = \frac{\pi^2 \sqrt{8.104 \times 1.653 \times 10^{10}}}{(532)^2} = 1.276 \times 10^6 \text{ lb/in}$$

$$\bar{N}_y^* = 2.572 \times 10^5 \text{ lb/in}$$

$$\frac{\bar{N}_y}{\bar{N}_y^*} = 0.041$$

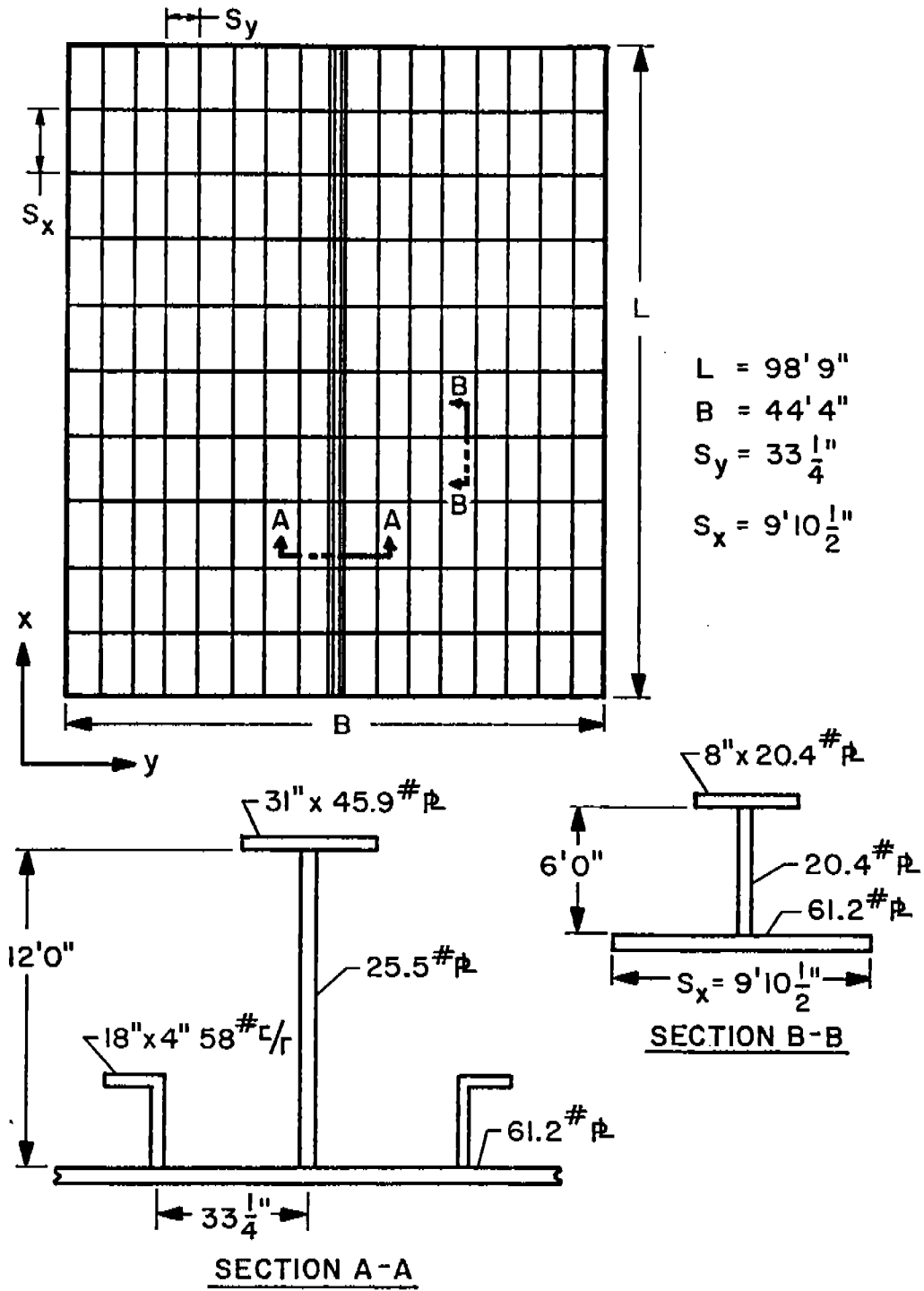

FIGURE 16 - GROSS PANEL, 70,000 DWT TANKER

From equation (IV), the smallest value of $\frac{\bar{N}_x}{\bar{N}_x^*}$ occurs when $m=2$ and $n=1$.

$$\frac{\bar{N}_x}{\bar{N}_x^*} = 3.56 \quad \text{thus,} \quad (\bar{N}_x)_{cr} = 2030 \text{ tons/in}$$

Example 2:

Consider next a section of the gross panel of the 70,000 DWT tanker between transverse web frames. Figure 17 shows a typical section dimension and stiffener cross section. The following values were computed [60].

$$D_x = 4.044 \times 10^8 \text{ lb-in}$$

$$D_y = 9.272 \times 10^6 \text{ lb-in}$$

$$\rho = 0.173$$

$$\eta = 0.73$$

$$\bar{N}_y^* = \frac{\pi^2 \sqrt{4.044 \times 9.272 \times 10^7}}{(118.5)^2} = 43,036 \text{ lb/in}$$

$$\bar{N}_x^* = 8,541 \text{ lb/in}$$

For a transverse inplane load $\bar{N}_y = 10,554 \text{ lb/in}$ due to an "Lpp/20" wave draft, the ratio:

$$\frac{\bar{N}_y}{\bar{N}_y^*} = \frac{10,554}{43,036} = 0.245$$

From equation (IV) $\frac{\bar{N}_x}{\bar{N}_x^*}$ is minimum when $m=1$, $n=1$ and is equal to the following.

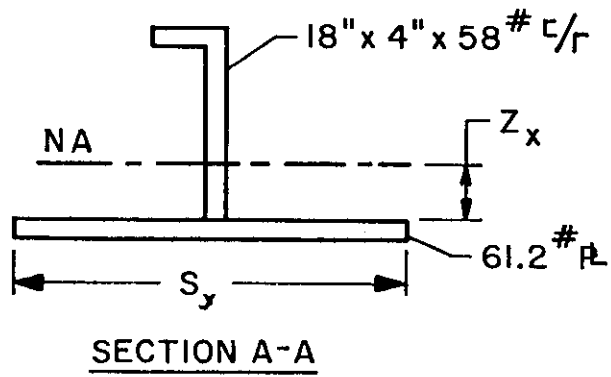
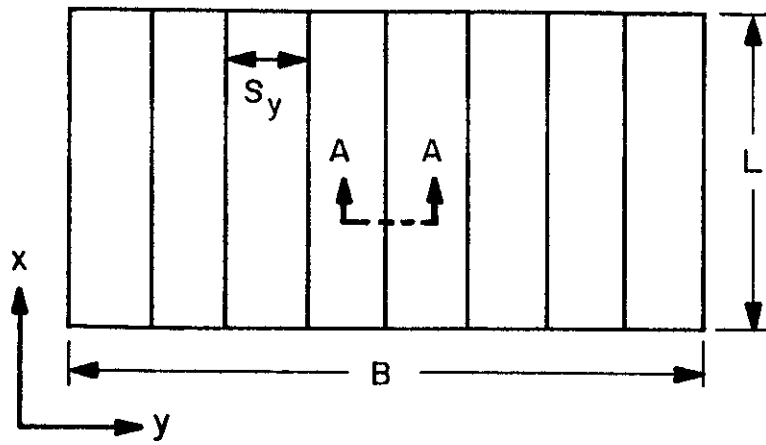

FIGURE 17 - PANEL BETWEEN TRANSVERSE FRAMES 70,000 DWT TANKER

$$\frac{\bar{N}_x}{N_x^*} = 34.66$$

and

$$(\bar{N}_x)_{cr} = 132 \text{ tons/in}$$

Example 3:

Consider next a section between two longitudinals and two web frames. The resulting isotropic plate has the following dimensions.

$$a = 118.5 \text{ in.} \quad ; \quad b = 33.25 \text{ in.}$$

and

$$D_x = D_y = D = \frac{E h^3}{12 (1-\nu^2)} = 9.272 \times 10^6 \text{ lb. in.}$$

$$\rho = \frac{a}{b} = \frac{118.5}{33.25} = 3.56$$

$$\eta = 1.0$$

$$\bar{N}_y^* = \frac{\pi^2 D}{a^2} = 6,517 \text{ lb/in}$$

$$\bar{N}_x^* = \frac{\pi^2 D}{b^2} = 82,773 \text{ lb/in}$$

thus,

$$\frac{\bar{N}_y}{\bar{N}_y^*} = \frac{10,554}{6,517} = 1.62$$

From equation (IV) the minimum critical load in the x-direction occurs when $m=3$, $n=1$ and is equal to:

$$\frac{\bar{N}_x}{\bar{N}_x^*} = 3.94$$

from which,

$$(\bar{N}_x)_{cr} = 145.6 \text{ tons/in}$$

From the results of Examples 1, 2, and 3 it is seen that the lowest buckling mode of the gross panel under biaxial loading conditions is that of the panel between web frames.

UNCLASSIFIED

Security Classification

DOCUMENT CONTROL DATA - R & D

Security classification of title, body of abstract and indexing annotation must be entered when the overall report is classified

24. ORIGINATING ACTIVITY (Corporate author) Mansour Engineering, Inc. Berkeley, CA 94704		23. REPORT SECURITY CLASSIFICATION UNCLASSIFIED	
25. GROUP			
REPORT TITLE GROSS PANEL STRENGTH UNDER COMBINED LOADING			
4. DESCRIPTIVE NOTES (Type of report and inclusive dates) FINAL REPORT			
5. AUTHOR(S) (First name, middle initial, last name) Alaa E. Mansour			
6. REPORT DATE		7a. TOTAL NO. OF PAGES 72	7b. NO. OF REFS 70
8a. CONTRACT OR GRANT NO. N00024-75-C-4015		9a. ORIGINATOR'S REPORT NUMBER(S)	
b. PROJECT NO. SR-225			
c.		9b. OTHER REPORT NO(S) (Any other numbers that may be assigned this report)	
d.			
10. DISTRIBUTION STATEMENT Distribution of this document is unlimited			
11. SUPPLEMENTARY NOTES		12. SPONSORING MILITARY ACTIVITY Naval Ship Engineering Center	
13. ABSTRACT The existing methods of predicting the behavior and ultimate strength of ship gross panels were evaluated, examined and in some instances, further developed. The assumptions, approximations, and deficiencies in each method were identified with the objective of determining the range of validity of each. The methods were classified in five broad categories with respect to their theoretical bases. Comparisons and correlations were conducted between the results of the different methods when applied to identical gross panels under biaxial edge compression and lateral pressure. Based on the identification of the assumptions and approximations in each method, and on the conducted comparisons and correlations, some expressions and procedures were selected, discussed, and extended. Lack of adequate procedures in certain areas were pointed out particularly when the collapse loads and mechanisms involve coupling between several modes of failure, and a biaxial loading condition exists in combination with lateral pressure. In some instances no clear measure of the relative reliability of the different procedures can be ascertained and a firm evidence of the "exact" solution is not available. A two-phase test program was recommended with immediate objectives and final goals outlined. An extensive bibliography is appended to this report.			

METRIC CONVERSION FACTORS

Approximate Conversions to Metric Measures

Symbol	When You Know	Multiply by	To Find	Symbol
LENGTH				
in	inches	2.5	centimeters	cm
ft	feet	30	centimeters	cm
yd	yards	0.9	meters	m
mi	miles	1.6	kilometers	km
AREA				
in ²	square inches	6.5	square centimeters	cm ²
ft ²	square feet	0.09	square meters	m ²
yd ²	square yards	0.8	square meters	m ²
mi ²	square miles	2.6	square kilometers	km ²
	acres	0.4	hectares	ha
MASS (weight)				
oz	ounces	28	grams	g
lb	pounds	0.45	kilograms	kg
	short tons (2000 lb)	0.9	tonnes	t
VOLUME				
tsp	teaspoons	5	milliliters	ml
Tbsp	tablespoons	15	milliliters	ml
fl oz	fluid ounces	30	milliliters	ml
c	cups	0.24	liters	l
pt	pints	0.47	liters	l
qt	quarts	0.95	liters	l
gal	gallons	3.8	liters	l
ft ³	cubic feet	0.03	cubic meters	m ³
yd ³	cubic yards	0.76	cubic meters	m ³
TEMPERATURE (exact)				
°F	Fahrenheit temperature	5/9 (after subtracting 32)	Celsius temperature	°C

¹ 1 in. = 2.54 (exactly). For other exact conversions and more detailed tables, see NBS Misc. Publ. 286, Units of Weights and Measures, Price \$2.25, SD Catalog No. C13.10 286.



Approximate Conversions from Metric Measures

Symbol	When You Know	Multiply by	To Find	Symbol
LENGTH				
mm	millimeters	0.04	inches	in
cm	centimeters	0.4	inches	in
m	meters	3.3	feet	ft
m	meters	1.1	yards	yd
km	kilometers	0.6	miles	mi
AREA				
cm ²	square centimeters	0.16	square inches	in ²
m ²	square meters	1.2	square yards	yd ²
km ²	square kilometers	0.4	square miles	mi ²
ha	hectares (10,000 m ²)	2.5	acres	
MASS (weight)				
g	grams	0.035	ounces	oz
kg	kilograms	2.2	pounds	lb
t	tonnes (1000 kg)	1.1	short tons	
VOLUME				
ml	milliliters	0.03	fluid ounces	fl oz
l	liters	2.1	pints	pt
l	liters	1.06	quarts	qt
l	liters	0.26	gallons	gal
m ³	cubic meters	35	cubic feet	ft ³
m ³	cubic meters	1.3	cubic yards	yd ³
TEMPERATURE (exact)				
°C	Celsius temperature	9/5 (then add 32)	Fahrenheit temperature	°F

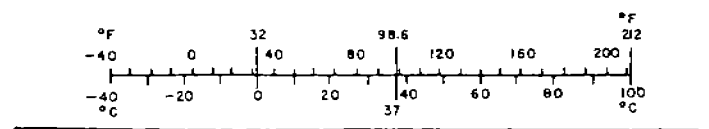

SHIP RESEARCH COMMITTEE
Maritime Transportation Research Board
National Academy of Sciences-National Research Council

The Ship Research Committee has technical cognizance of the interagency Ship Structure Committee's research program:

MR. O. H. OAKLEY, Chairman, *Consultant, McLean, Virginia*
MR. M. D. BURKHART, *Head, Marine Science Affairs, Office of Oceanographer of the Navy*
DR. J. N. CORDEA, *Senior Staff Metallurgist, APMCO Steel Corporation*
MR. D. P. COURTSAL, *Vice President, DRAVO Corporation*
MR. E. S. DILLON, *Consultant, Silver Spring, Maryland*
DEAN D. C. DRUCKER, *College of Engineering, University of Illinois*
MR. W. J. LANE, *Consultant, Baltimore, Maryland*
MR. R. W. RUMKE, *Executive Secretary, Ship Research Committee*

The Ship Design, Response, and Load Criteria Advisory Group prepared the project prospectus and evaluated the proposals for this project:

MR. W. J. LANE, Chairman, *Consultant, Baltimore, Maryland*
PROF. A. H.-S. ANG, *Dept. of Civil Engineering, University of Illinois*
PROF. S. H. CRANDALL, *Dept. of Mechanical Engineering, Massachusetts Institute of Technology*
DR. M. K. OCHI, *Research Scientist, Naval Ship R & D Center, Bethesda, MD*
PROF. W. D. PILKEY, *Dept. of Mechanics, University of Virginia*
PROF. H. E. SHEETS, *Chairman, Dept. of Ocean Engrg., University of Rhode Island*
MR. H. S. TOWNSEND, *Consultant, Westport, Connecticut*

The SR-225 Project Advisory Committee provided the liaison technical guidance, and reviewed the project reports with the investigator:

PROF. J. E. GOLDBERG, Chairman, *School of Civil Engrg., Georgia Inst. of Tech.*
PROF. G. A. WEMPNER, *School of Engrg. Science & Mechanics, Georgia Inst. of Tech.*
PROF. M. SHINOZUKA, *Dept. of Civil Engineering, Columbia University*

SHIP STRUCTURE COMMITTEE PUBLICATIONS

These documents are distributed by the National Technical Information Service, Springfield, Va. 22151. These documents have been announced in the Clearinghouse journal U.S. Government Research & Development Reports (USGRDR) under the indicated AD numbers.

- SSC-256, *Dynamic Crack Propagation and Arrest in Structural Steels* by G. T. Hahn, R. G. Hoagland, and A. R. Rosenfield. 1976. AD-A021339.
- SSC-257, (SL-7-5) - *SL-7 Instrumentation Program Background and Research Plan* by W. J. Siekierka, R. A. Johnson, and CDR C. S. Loosmore, USCG. 1976. AD-A021337.
- SSC-258, *A Study to Obtain Verification of Liquid Natural Gas (LNG) Tank Loading Criteria* by R. L. Bass, J. C. Hokanson, and P. A. Cox. 1976. AD-A025716.
- SSC-259, (SL-7-6) - *Verification of the Rigid Vinyl Modeling Technique: The SL-7 Structure* by J. L. Rodd. 1976. AD-A025717.
- SSC-260, *A Survey of Fastening Techniques for Shipbuilding* by N. Yutani and T. L. Reynolds. 1976. AD-A031501.
- SSC-261, *Preventing Delayed Cracks in Ship Welds - Part I* by H. W. Mishler. 1976. AD-A031515.
- SSC-262, *Preventing Delayed Cracks in Ship Welds - Part II* by H. W. Mishler. 1976. AD-A031526.
- SSC-263, (SL-7-7) - *Static Structural Calibration of Ship Response Instrumentation System Aboard the Sea-Land McLean* by R. R. Boentgen and J. W. Wheaton. 1976. AD-A031527.
- SSC-264, (SL-7-8) - *First Season Results from Ship Response Instrumentation Aboard the SL-7 Class Containership S.S. Sea-Land McLean in North Atlantic Service* by R. R. Boentgen, R. A. Fain and J. W. Wheaton. 1976. AD-A039752.
- SSC-265, *A Study of Ship Hull Crack Arrestor Systems* by M. Kanninen, E. Mills, G. Hahn, C. Marschall, D. Broek, A. Coyle, K. Masubushi and K. Itoga. 1976. AD-A040942.
- SSC-266, *Review of Ship Structural Details* by R. Glasfeld, D. Jordan, M. Kerr, Jr., and D. Zoller. 1977. AD-A040941.
- SSC-267, *Compressive Strength of Ship Hull Girders - Part III - Theory and Additional Experiments* by H. Becker and A. Colao. 1977.
- SSC-268, *Environmental Wave Data for Determining Hull Structural Loadings* by D. Hoffman and D. A. Walden. 1977.
- SSC-269, *Structural Tests of SL-7 Ship Model* by W. C. Webster and H. G. Payer. 1977.