

SSC-273

**SURVEY OF
STRUCTURAL TOLERANCES
IN THE UNITED STATES
COMMERCIAL SHIPBUILDING
INDUSTRY**

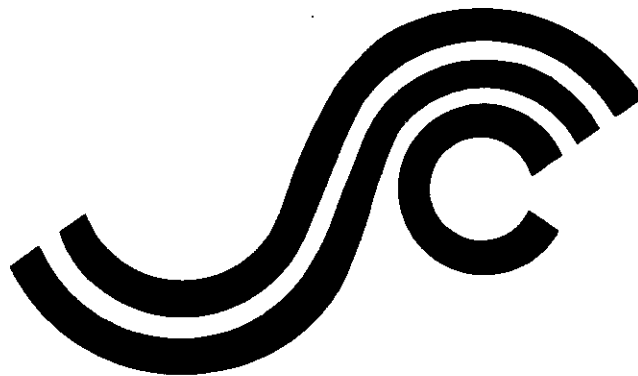

**This document has been approved
for public release and sale; its
distribution is unlimited.**

**SHIP STRUCTURE COMMITTEE
1978**

SHIP STRUCTURE COMMITTEE

**AN INTERAGENCY ADVISORY
COMMITTEE DEDICATED TO IMPROVING
THE STRUCTURE OF SHIPS**

MEMBER AGENCIES:

UNITED STATES COAST GUARD
NAVAL SHIP SYSTEMS COMMAND
MILITARY SEALIFT COMMAND
MARITIME ADMINISTRATION
AMERICAN BUREAU OF SHIPPING

ADDRESS CORRESPONDENCE TO:

SECRETARY
SHIP STRUCTURE COMMITTEE
U.S. COAST GUARD HEADQUARTERS
WASHINGTON, D.C. 20591

SR-1233

With the vast increase in ship size during the past two decades, great emphasis has been placed on reducing hull scantlings through rational determination of loads, working stresses and material properties. To support an extended use of rational analysis in ship design, it is necessary to determine the deviations from "ideal" design that can be expected in construction and their effects during the vessel's service life.

The Ship Structure Committee initiated a project to determine the factors leading to and the extent of deviation from theoretical design that can be expected.

This is the final report of that project and is being published to assist in developing a rational approach to ship design.



W. M. Benkert
Rear Admiral, U.S. Coast Guard
Chairman, Ship Structure Committee

FINAL REPORT

on

Project SR-1233

"Structural Tolerance Survey"

SURVEY OF STRUCTURAL TOLERANCES IN THE UNITED
STATES COMMERCIAL SHIPBUILDING INDUSTRY

by

N. S. Basar
R. F. Stanley

M. Rosenblatt & Son, Inc.

under

Department of the Navy
Naval Ship Engineering Center
Contract No. N00024-76-C-4059

*This document has been approved for public release
and sale: its distribution is unlimited.*

U. S. Coast Guard Headquarters
Washington, D.C.
1978

ABSTRACT

Deviations from ideal structural design of different types of vessels during construction and service are investigated. Selected U.S. commercial shipyards, ship owner/operators, steel mills, and foreign classification societies are surveyed or interviewed with the purpose of documenting major deviations and recurring structural imperfections, and determining the factors leading to these deviations. An effort is also made to determine the extent of deviations from theoretical design and to establish, wherever possible, structural tolerance limits which are most commonly used in U.S. yards and which can therefore be considered representative of U.S. shipbuilding practice. These are compared to published international structural tolerance standards, and recommendations are given for further study.

CONTENTS

	<u>Page</u>
ABSTRACT	ii
List of Tables	iv
List of Figures	v
Section 1. INTRODUCTION	1-1
1.1 Background	1-1
1.2 Objective and Scope	1-2
1.3 Limitations of Surveys	1-3
Section 2. SURVEY METHODOLOGY	2-1
2.1 General	2-1
2.2 Standard Survey Format	2-2
2.3 Scope of Vessels for Actual Surveys	2-2
Section 3. STRUCTURAL SYSTEMS/SUBSYSTEMS AND DEVIATIONS	3-1
3.1 Structural Imperfections/Deviations	3-4
3.2 Extent of Consideration for Each Deviation	3-6
Section 4. DISCUSSION OF SURVEY RESULTS AND TRENDS	4-1
4.1 Shipowners and Operators	4-2
4.2 Shipyards and Steel Fabricating Facilities	4-5
4.3 Steel Mills	4-23
4.4 Classification Societies	4-24
4.5 Foreign Institutions	4-29
4.6 Overview	4-29
Section 5. FOLLOW THROUGH OF A TYPICAL STRUCTURAL DEVIATION	5-1
5.1 Factors Related to Ideal Design	5-1
5.2 Influence of Structural Deviations on Strength	5-8
Section 6. CONCLUSIONS	6-1
Section 7. RECOMMENDATIONS	7-1
7.1 Recommended Guide to U.S. Shipyard Practice in Structural Tolerances	7-1
7.2 Relation of Tolerances to Rational Design	7-1
7.3 Quality Assurance and Inspection Requirements in Shipyards	7-4
Section 8. REFERENCES	8-1
ACKNOWLEDGEMENT	8-3
Section 9. APPENDIXES	9-1
9.1 Bibliography	9-1
9.2 U.S. Commercial Shipyard Standards	9-8
9.3 Existing International Standards	9-63

LIST OF TABLES

<u>Table No.</u>	<u>Description</u>	<u>Page No.</u>
4.1	Structural Tolerance Standards as Reported by Shipowners/Operators	4-4
4.2	Deviations and Tolerances at Shipyards	4-8
6.1	Comparison of USA Practice in Structural Tolerances with Published International Standards	6-3
7.1	Structural Tolerances in United States Shipyards	7-2

LIST OF FIGURES

<u>Figure No.</u>	<u>Description</u>	<u>Page No.</u>
4.1	Bulkhead Misalignment	4-3
4.2	Damage Occurrence Rate by Age of Vessel	4-6
4.3	Example of Poor Detailing of Design	4-6
4.4	Graphical Representation of Reported Struc- tural Deviations and Tolerances	4-18
4.5	A. Full Penetration Weld	4-27
	B. Alternate Detail	4-27
	C. Explosion Bonding	4-27
5.1	General Relationship of Cost to Dimen- sional Accuracy	5-5
5.2	Alignment of Subassemblies	5-5
5.3	Detail Design of a Beam Bracket	5-9
5.4	Effects of Weld Undercut	5-11
7.1	Critical Quality Areas	7-3

SHIP STRUCTURE COMMITTEE

The SHIP STRUCTURE COMMITTEE is constituted to prosecute a research program to improve the hull structures of ships by an extension of knowledge pertaining to design, materials and methods of fabrication.

RADM W. M. Benkert, USCG (Chairman)
Chief, Office of Merchant Marine Safety
U.S. Coast Guard Headquarters

Mr. P. M. Palermo
Asst. for Structures
Naval Ship Engineering Center
Naval Ship Systems Command

Mr. M. Pitkin
Asst. Administrator for
Commercial Development
Maritime Administration

Mr. John L. Foley
Vice President
American Bureau of Shipping

Mr. C. J. Whitestone
Engineer Officer
Military Sealift Command

SHIP STRUCTURE SUBCOMMITTEE

The SHIP STRUCTURE SUBCOMMITTEE acts for the Ship Structure Committee on technical matters by providing technical coordination for the determination of goals and objectives of the program, and by evaluating and interpreting the results in terms of ship structural design, construction and operation.

NAVAL SEA SYSTEMS COMMAND

Mr. R. Johnson - Member
Mr. J. B. O'Brien - Contract Administrator
Mr. C. Pohler - Member
Mr. G. Sorokin - Member

U.S. COAST GUARD

LCDR T. H. Robinson - Secretary
LCDR S. H. Davis - Member
CAPT C. B. Glass - Member
Dr. W. C. Dietz - Member

MARITIME ADMINISTRATION

Mr. F. Dashnaw - Member
Mr. N. Hammer - Member
Mr. R. K. Kiss - Member
Mr. F. Seibold - Member

MILITARY SEALIFT COMMAND

Mr. T. W. Chapman - Member
CDR J. L. Simmons - Member
Mr. A. B. Stavovy - Member
Mr. D. Stein - Member

AMERICAN BUREAU OF SHIPPING

Mr. S. G. Stiansen - Chairman
Dr. H. Y. Jan - Member
Mr. I. L. Stern - Member

NATIONAL ACADEMY OF SCIENCES SHIP RESEARCH COMMITTEE

Mr. O. H. Oakley - Liaison
Mr. R. W. Rumke - Liaison

SOCIETY OF NAVAL ARCHITECTS & MARINE ENGINEERS

Mr. A. B. Stavovy - Liaison

WELDING RESEARCH COUNCIL

Mr. K. H. Koopman - Liaison

INTERNATIONAL SHIP STRUCTURES CONGRESS

Prof. J. H. Evans - Liaison

U.S. COAST GUARD ACADEMY

CAPT W. C. Nolan - Liaison

STATE UNIV. OF N.Y. MARITIME COLLEGE

Dr. W. R. Porter - Liaison

AMERICAN IRON & STEEL INSTITUTE

Mr. R. H. Sterne - Liaison

U.S. NAVAL ACADEMY

Dr. R. Bhattacharyya - Liaison

U.S. MERCHANT MARINE ACADEMY

Dr. Chin-Bea Kim - Liaison

1.0 INTRODUCTION

1.1 Background

A ship or any vessel, like any other complex structure, is subjected to certain imperfections or deviations from their ideal structural design during construction. The deviation can be avoidable or unavoidable depending on its location, ease of inspection, and the possibility of accomplishing corrective action.

For purposes of clarity, it may be desirable to first attempt a definition of the "ideal design."

The structural design of ships is based on strength calculations performed using the dimensional characteristics of the vessel, the loading criteria for the service the vessel is to be employed in, and the prevailing sea-states. Assumptions are made in carrying out the design, and safety factors are used to compensate for unknown or unpredictable parameters. The structural model of ships developed in this fashion is expected to perform its intended service under all conditions. This is labelled the "ideal design."

The ideal design assumes that the finished construction will represent accurately the configuration shown on the theoretical structural drawings. Even though there have been cases where allowance was made in the ideal design for certain major deviations, in general, a great majority of newly constructed vessels do not have any such allowance associated with their design except for what is intrinsically allowed in the classification society rules.

Yet in everyday practice, it is impossible to maintain an exact duplication of the geometric configuration depicted on ideal design drawings on the physical ship being constructed. The ideal design is deviated from during the production of shipbuilding materials, during fabrication and assembly operations, and during erection on the building ways. These deviations may consist of flaws in base material, errors in fit-up and alignment work, unfairness of plating, errors originating from the manufacturing processes used, and errors in the detail design of structures.

A ship may develop additional imperfections or deviations from the ideal design during its service life. These "in-service" deviations may originate from the actual service conditions of the vessel. Impact loads experienced during operations in heavy seas, or mechanical damage during operations in port or at sea, may result in deviations such as unfairness of the plating, distortion or deflection of structural members, or reduction of steel thickness due to corrosion, etc. If an initial imperfection exists on a newly built vessel, the service conditions may cause a worsening of an otherwise tolerable deviation and lead to brittle fracture or fatigue cracks.

Even with today's technology, which allows the use of improved quality shipbuilding materials, much improved manual or automatic fabrication and assembly procedures, sophisticated welding techniques, and new non destructive testing methods, some shipbuilders may not be, for varying reasons, in a position to fully utilize these improvements and provide a finished product reflecting the available technology. Furthermore, even when all available technology is fully utilized, it is still impossible to eliminate all structural imperfections due to the inherent errors in the automatic fabrication equipment and the human factors involved. The apparent result of this situation is that the ships built by one shipbuilder, even if the same ideal design drawings are followed, may be and almost always are not equivalent to each other from a structural accuracy viewpoint.

1.2 Objective and Scope

The overall objective of the present study is to determine and document the present-day hull construction and inspection procedures to determine the factors leading to and the extent of structural deviations from the ideal theoretical design in U.S. shipyards.

The original requirements for the study, as specified by the Ship Structure Committee, were the following:

1. Approximately twelve U.S. shipyards and representative steel producers supplying material for, constructing, or repairing ocean-going vessels should be surveyed.
2. Shipowners/Operators and classification agencies should also be interviewed.
3. The study should cover the range from unmanned and/or unpowered ocean going barges to fully powered vessels.
4. The surveys should consider deviations from ideal design occurring during construction and service including:
 - a. Poor detailing of design
 - b. Flaws in base material and thickness variations
 - c. Fit-up alignment
 - d. Welding flaws
 - e. Unfairness and deflection
 - f. Forming and strengthening practices
5. The "in-service" deviations should exclude deviations due to damage from collision, grounding or similar accidents.
6. Major deviations and recurring items are to be explored and documented.
7. The study should identify the normal deviations experienced for the factors involved as well as the maximum deviations expected. The findings should be correlated by ship type, in-shop or on-ship work, and the type of shipyard facilities, (e.g. repair versus new construction).

8. No experimental or ship instrumentation work was envisioned.

As described in greater detail in Section 2, the scope of the survey was expanded during actual performance of the investigation to cover nineteen shipyards or steel fabricating plants rather than the twelve required in order to obtain a more representative cross-section of the U.S. Shipbuilding industry, and also to cover as many ship types as possible.

1.3 Limitations of Surveys

As touched upon briefly in Section 2, it would have been desirable to conduct detailed and in-depth surveys, especially in shipyards, to enable the project team to develop distribution curves of the deviations measured in a quantity sufficient to permit statistical analysis. This, however, was not possible. The quantity of structural deviations data obtained was rather limited partly due to the fact that the yards did not maintain a statistical record and partly due to the fact that actual measurements proved to be difficult to carry out in that it interfered with the yard's work in progress.

As far as "in service" deviations are concerned, again not enough data were available from the classification societies due to the simple fact that this type of data is not being recorded and sometimes not even reported. It is probable however that they are not reported due to following reasons:

- a. The causes are difficult to determine.
- b. Measurements of deviations are often impossible.
- c. Even if the causes could be determined, the surveyors may still be reluctant to report these because they may be subject to libel suits.

This last reason led the International Ship Structures Congress in their 1976 report (1)* to recommend for future research the establishment of a comprehensive "Damage Recording System". The report cites the need for all parties concerned, i.e., the Classification societies, Shipowners, and Ship repairers to take a more liberal view of the subject and to release information of this type for the benefit of the industry.

The range of vessel types specified for the surveys could not be fully covered due to the fact that some vessel types were not being constructed in U.S. commercial shipyards during the period of surveys. This limitation is further discussed in Section 2.3.

The data on structural deviations were identified at the time of documenting them during surveys as to whether they represented shop or field work and also as to what ship type they referred to. In compiling and analyzing the data however, it was decided that, since the shop deviations are either eventually eliminated by corrective action or they become field type deviations when assembled in place

*Numbers in parenthesis denote similarly numbered references in Section 8.

as-is, only "on-ship" type deviations would be considered for tabulations. Still, however, because of their very nature, some deviations such as cutting line accuracy, edge preparations, groove depth etc., necessarily reflect "in-shop" operations.

The results of surveys, in the form of structural deviation and tolerance data are reported in Section 4 separately for owners, yards, class societies, and steel mills, and the emerging general trends are discussed.

Additionally, in Section 5.0, a typical structural deviation is individually considered throughout all phases of ship design, construction, and service and the importance of maintaining tolerances is investigated.

2.0 SURVEY METHODOLOGY

2.1 General

A number of international agencies/institutions have developed and published ship structural tolerance standards and/or compiled listings of same in use in their respective countries at the time of publication.

The most widely known structural tolerance standards are those developed in Japan by the joint efforts of the Society of Naval Architects of Japan and the University of Tokyo. The "Japanese Shipbuilding Quality Standards- Hull Part" as it is referred to (2) was first published in 1965 and was subsequently revised and re-edited in 1971, 1973, and 1975, to reflect the changing shipbuilding technology.

The Japanese approach in developing these standards is described in (3): Briefly, the approach consists of taking actual measurements of structural deviations in a number of Japanese shipyards, developing histograms of the measured deviations and, from these distributions, establishing the mean standard (range) and the maximum allowable value (tolerance) for each structural deviation considered. A similar but more limited approach was found desirable for the present project.

As a first step all reference material compiled was carefully reviewed, and various ways of listing the structural deviations were noted. The listings in the Japanese, German and Swedish shipbuilding tolerance standards were used but rearranged to conform to the following sequence as specified by the Ship Structure Committee:

- a. Fit-up and alignment
- b. Unfairness and deflection
- c. Forming and straightening practices
- d. Welding flaws - butt, fillet, laps, and corners
- e. Flaws in base material and thickness variations
- f. Poor detailing of design

The list of deviations developed was used in pilot surveys conducted with two shipyards, two shipowners, four classification societies, and one steel mill for the purpose of testing its usefulness. In the pilot surveys, the scope of the surveys were defined and revised after each survey to reflect the experience gained and also to make it easier to extract relevant structural tolerance information from the institutions visited.

The following conclusions were made upon completion of the pilot surveys:

1. The list of deviations, with minor revision, could be used in surveys at shipyards. Each yard could be given a copy of the list and asked to fill in the appropriate columns for normally experienced and allowable maximum deviations to the extent that this information exists and is being used.

2. The ship owners do not normally have as detailed information on structural deviations and tolerances; therefore, the list of deviations could be used as a guide in obtaining whatever information the owners/operators may have available to them.

3. For purposes of facilitating the data evaluation work, it is desirable to list all the probable questions that the shipyards may be asked to answer in connection with their quality assurance capabilities, inspection criteria, and statistical or other deviation/tolerance records.

4. Visits to various institutions, especially shipyards, have to be of short duration and take a minimum of time away from the yard personnel due to their pressing every day type work responsibilities.

5. It would be desirable, and mostly possible, to contact the regulatory body resident surveyors and owners' representatives stationed in each shipyard, and to obtain their input regarding structural tolerances and quality control requirements and procedures.

6. Informal talks with the yard's engineering department, and especially with the hull design group, would be necessary in order to explore the yard's approach to recommended corrective action for any excessive deviations noted and in order to document their procedure for detailed design review and checking of the original structural design against any deviations/deficiencies/deformations that may be left uncorrected in the vessel under construction.

2.2 Standard Survey Format

Utilizing the experience gained from pilot surveys, and considering the general shipyard response to be expected during the visits, a format was developed for use as a standard procedure during final surveys.

The format contained:

- a. Definition of the scope of survey
- b. Questionnaire
- c. List of deviations

2.3 Scope of Vessels for Actual Surveys

Final surveys were conducted at eighteen shipbuilding yards and one steel fabricating plant, on the following types of vessels:

Oil Tankers (33,000 to 265,000 DWT)
Roll On/Roll Off Vessels (14,500 to 17,000 DWT)
LNG Carriers (63,600 DWT)
Barges (250 to 400 Feet)
Drilling Rigs (Jack-up & Semi-submersible)
Drilling Ships

3.0 STRUCTURAL SYSTEMS/SUBSYSTEMS AND DEVIATIONS

The complete cycle of design, fabrication, subassembly, assembly, erection, and operation of a ship is considered phase by phase for determining and listing the structural systems and subsystems to be investigated in the present study. The underlying thought is the effect of each phase or process on the ship's structural systems and the possibility of creating or causing a structural deviation or imperfection.

Specifically, the following stages and processes are considered:

Contract Design - to determine any inferior quality details or arrangements affecting the quality of detail design.

Detail Design - Insufficient or inferior quality details or manufacturing processes specified in the detail working drawings.

Base Materials - Any deviations in the actual materials delivered to the yard from the ideal materials as specified in the plans and specifications and the effect of these deviations on the structural quality of the ship being constructed.

Fabrication Methods and Processes - Lofting, cutting, forming, straightening, and welding methods, and equipment and tools used in the yard during fabrication, and the structural deviations originating from errors or lack of quality in these operations.

Assembly and Erection Procedures - Inaccuracies or imperfections in the assembly methods and erection processes followed in the yard, and their role in causing structural deviations in the finished product.

Inspection and Quality Assurance Procedures - Lack or insufficiency of inspection and quality control operations during various stages of vessel construction and structural deviations caused by these factors as well as by temperature fluctuations, improper or insufficient staging for larger vessels, and the misalignment, deflection and sinkage of building ways, basins or docks.

Service Factors - Effects of corrosion, coatings, and overall maintenance procedures on causing structural deviations; and also any deflections or similar imperfections which may be developed due to impact and shock loadings during a ship's service life.

A listing of all possible structural deviations affecting the structural systems and subsystems existing on a vessel is developed as a result of the above consideration. This listing is compared to some of the compilations in existing international shipbuilding standards (2,15,16) and

is also reviewed to ensure that it meets the guidelines set forth by the Ship Structure Committee (SSC).

The original list as developed to satisfy the sequence specified by the SSC had the following outline:

1. Fit-up Alignment
 - 1.1 Marking
 - 1.1.1 Accuracy of Cutting Line
 - 1.1.2 Panel Block Marking Compared with Correct Location
 - 1.2 Edge Preparation
 - 1.2.1 Roughness of Free Edge
 - 1.2.2 Roughness of Weld Groove
 - 1.2.3 Notches on Free Edge
 - 1.2.4 Notches on Weld Groove
 - 1.2.5 Dimensional Accuracy
(including bevels for welding)
 - 1.3 Component Parts Fabrication
 - 1.3.1 Longitudinal Flanges & Flanged Brackets
 - 1.3.2 Angles and Built-up Plates
 - 1.3.3 Plates
 - 1.4 Alignment
 - 1.4.1 Minimum Distance of Weld to Adjacent Weld
 - 1.4.2 Gap Between Members
 - 1.4.3 Fitting Accuracy
 - 1.5 Subassembly
 - 1.5.1 Permissible Distortion of Beams
 - 1.5.2 Dimensional Accuracy of Subassembly
 - 1.5.3 Alignment of Subassembly
2. Unfairness and Deflection
 - 2.1 Accuracy of Hull Form
 - 2.1.1 Principal Dimensions
 - 2.1.2 Deformation of Hull Form
 - 2.2 Deformation of Main Structural Members
 - 2.2.1 Unfairness
 - 2.2.2 Miscellaneous Deviations
3. Final Work & Finishing Practices
 - 3.1 Finishing up Traces of Temporary Pieces
 - 3.2 Surface Defects
 - 3.3 Treatment of Openings Cut for Temporary Purposes or by Error
 - 3.4 Hatch Coamings
 - 3.5 Access Openings
 - 3.6 Miscellaneous Pieces
 - 3.7 Tightness Tests
 - 3.8 Painting of Joint at Tightness Test or Inspection

4. Flaws in Welding Geometry
 - 4.1 Shape of Bead (including size, undercut, reinforcement)
 - 4.2 Distortion (Angular) of Welding Joint
 - 4.3 Short Bead
 - 4.4 Arc Strike
 - 4.5 Welding at Low Ambient Temperatures
 - 4.6 Weld Spatter
5. Flaws in Base Material
 - 5.1 Surface Flaws
 - 5.2 Laminations
 - 5.3 Steel Castings
6. Poor Detailing of Design
 - 6.1 Deficiencies in Contract Design
 - 6.2 Deficiencies in Detail Design

This was labelled the "List of Deviations" and was used in the surveys conducted in shipyards. It was also used as a guide in soliciting structural tolerance information from shipowners, class societies, and steel mills. It was slightly modified as results were obtained, however the general sequence remained unchanged.

When analyzing and evaluating the data obtained from the surveys, it was deemed appropriate to drop those deviations from the list for which no responses were given. One of the deviations dropped was "1.4.2 Gap Between Members". Originally, this was adopted as it existed in the Japanese Shipbuilding Quality Standards, JSQS (2), and it appeared that there was an overlap between this deviation and "Gap Before Welding, Fillet Weld". The latter was selected for use in tabulating the results.

The order of the remaining deviations for which responses have been obtained has been rearranged to better reflect the chronology of handling and treatment of material as it progresses from raw mill product to finished components on the ship.

The resulting listing of structural deviations can be related to the original sequence by their respective numbers as follows:

- A. Flaws and Size Deviations in Base Material (1)
- B. Cutting, Forming and Straightening Practices (2-8)
- C. Fit-up Alignment (9-11)
- D. Welding Flaws and Restrictions (12)
- E. Accuracy of Subassembly and Erection (13-23)

The structural imperfections and/or deviations considered in the final analysis are listed below and a brief description of the extent being considered for each is given immediately following the list.

3.1 Structural Imperfections/Deviations Considered

1. Receipt Inspection
 - a. Waviness
 - b. Thickness & Pits
 - c. Laminations
2. Cutting Line Accuracy (Comparison with correct line)
3. Edge Preparation (Roughness)
4. Edge Straightness for
 - a. Automatic Welding
 - b. Semi-automatic Welding
 - c. Manual Welding

5. Groove Depth

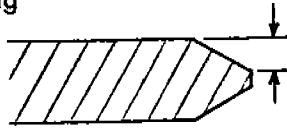

6. Taper Angle

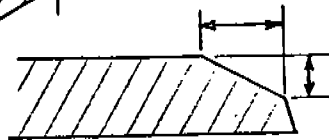

7. Fabricated Shapes

a. Flange Breadth



b. Angle



c. Straightness

i. Flange Plane

ii. Web Plane

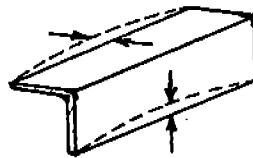

8. Rolled Shapes, Flange Angle

9. Gap Before Welding

a. Fillet

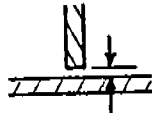

b. Butt



c. Lap

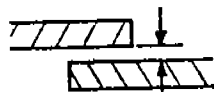

10. Beam and Frame Gap

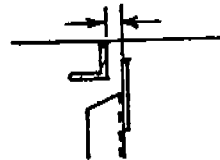

11. Butt Joint Misalignment

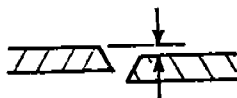

12. Weld Geometry
 a. Reinforcement



- b. Throat or Leg Length

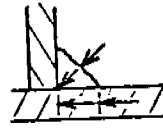

- c. Undercut

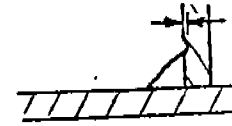

13. Intercostal Misalignment

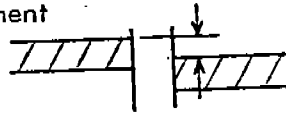

14. Profile Warp

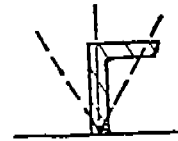

15. Stiffener Deviation from Straight Line

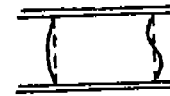

16. Adjacent Weld Spacing

- a. Butt to Butt

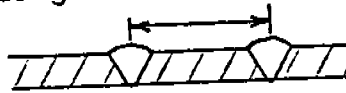

- b. Butt to Fillet

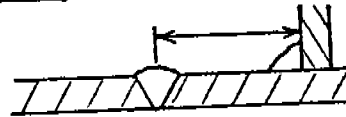

17. Cylinder Diameter

18. Curved Shell Accuracy

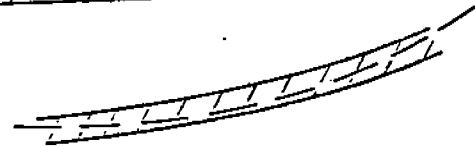

19. Subassembly Accuracy

- a. Length & Width

- b. Squareness

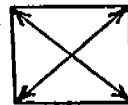

20. Hatch Coaming Dimensions

21. Access Openings

- a. Dimensions

- b. Deformation

22. Unfairness

- a. Bottom Shell

- b. Side Shell

- c. Deck

- d. Superstructure Side & End

23. Overall Dimensions

- a. Length
- b. Beam
- c. Depth
- d. Keel Flatness (Deviation from Straight Line)
- e. Forebody Rise

f. Afterbody Rise

g. Deadrise

h. Draft Marks

i. Freeboard Marks

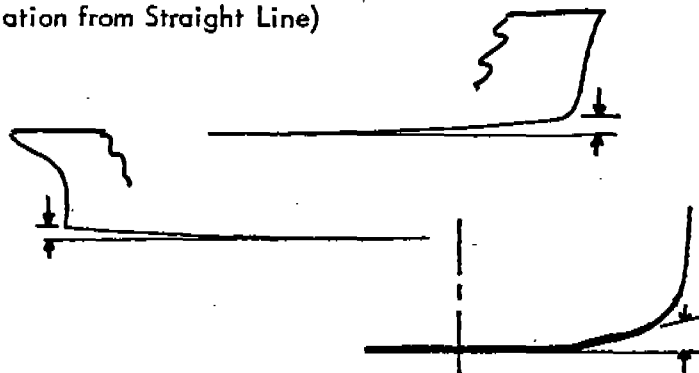

3.2 Extent of Consideration For Each Deviation

1. Receipt Inspection covers those material defects that should be checked to determine the acceptability of the material. Waviness can be corrected in the yard, but it must be detected before it can be corrected. Uncorrected, it leads to measurement and fit-up difficulties later.

Pits up to certain size can be faired by grinding; deeper pits must be filled with weld material. The tolerance limits are those for which even welding is not sufficient.

Laminations in rolled steel plate are produced by oblate shaped inclusions or fibers, of sulphide or oxide (slag). Either type causes the plate to act like several thinner plates stacked together to form a thicker one. Receipt inspection should reject plates with extensive laminations that are far in excess of limits.

2. Cutting Line Accuracy is the end product of several steps, including establishment of the guideline as well as the cutting operation itself.

3. Edge Preparation was to cover both welded edges and free edges, but only data for welded edges was reported.

4. Edge Straightness is similar to cutting line accuracy, except that the relationship to original design is not included. Its importance is mostly relevant to the production of good welds.

5 & 6. Groove Depth and Taper Angle are self-explanatory, but they are relevant only to those yards that do such preparation for weld joints.

7, 8, 9, 10 & 11 are self explanatory.

12. Weld Geometry: Undercut is a function of the digging effect of a welding arc, which melts a portion of the base material. If the arc is too long, the molten weld metal from the electrode may fall short and not completely fill this melted zone, leaving an undercut along the upper leg of the weld, or, in a butt weld, at either or both sides of the weld.

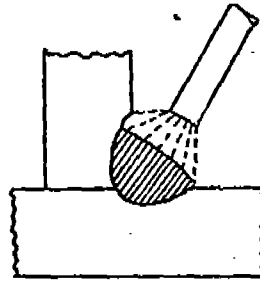

Reinforcement helps to prevent undercut. A nominal weld reinforcement of 1/16" above flush is recommended in welding handbooks.

13. Intercostal (or Cruciform Joint) Misalignment, is the classic tolerance problem.

14 & 15. Profile and Stiffener Deviations are functions of fit-up problems, both dependent on previous work and influential in following work.

16. Adjacent Weld Spacing is dependent on original design and on welding practices, especially pre-heat. It is not a tolerance problem, per se, but it can lead to distortions and locked in stresses.

17. Cylinder Diameter is relevant mostly to drill-rigs and similar exotic marine vehicles with large cylindrical structures.

18. Curved Shell Accuracy is a function of forming practices and is a major factor in shell unfairness.

19, 20, 21, 22 & 23 are self explanatory, except that some shipyards do not make any check on L, B, or D. Forebody Rise, Afterbody Rise, and Deadrise change are functions of welding-induced shrinkage and diurnal temperature changes, a problem that has been partly reduced but not eliminated by extra careful design and welding sequence.

4.0 DISCUSSION OF SURVEY RESULTS AND TRENDS

Results obtained from surveys are discussed in the following subsections. In the tabulations for reporting the responses to the survey questionnaire and the data supplied on deviations and tolerances, symbolic numbers and letters are used in place of the names of institutions.

4.1 SHIP OWNERS AND OPERATORS

Seventeen ship owner/operator executives or yard inspectors were interviewed to discuss their experiences with deviations in construction and in service on their ships. Some of the comments and discussions are given below, but since they had quite diverse operations, most of their comments do not fit neatly into tabular form.

The most commonly suggested tolerance problem was misalignment, especially misalignment of intercostals at cruciform intersections. Three ship owners/operators have approached the problem on an analytical basis, utilizing finite element analysis either to determine the maximum misalignment allowable before design joint efficiencies, stresses, and safety factors were exceeded, or to determine the mechanics of known failures. In one case; the owner/operator found that $t/3$ was the maximum acceptable misalignment for high stress, high-cycled joints. This result agrees with that presented in the background material for the Japanese Shipbuilding Quality Standards (3). Another found that many small discontinuities and misalignments that ordinarily were not bothersome to inspectors were the causes of small cracks in container ship box girders. This same owner/operator also found that misalignments of up to 1" in longitudinal bulkheads had caused fatigue cracking at cruciform joints with transverse bulkheads.

Two executives discussed the problem of plate panel distortion (unfairness) due to welding. One said that deflections up to 1/4" in shell plating were tolerable because they indicate that the weldments have "pulled" properly. The other stated that shipyard practices for straightening these deviations sometimes build up large residual stresses. He urged care and proper sequencing to prevent problems. At least three other owners/operators utilize curves for assessing permissible unfairness, based on NAVSHIPS 0900-000-1000 (4).

Various opinions were given on the subject of coatings to maintain structural strength and to reduce tabular corrosion allowances for plate thickness. Two oil tanker owners/operators found that the initial expenses plus the expense of re-coating after ten years were much more than the initial cost plus service expenses of simply having thicker steel plate. Two other tanker owners/operators said that deficiencies in coatings result in wastage, and that reducing this wastage would prolong ship life. The owners of a fleet of LNG tankers use inorganic zinc coatings in the ballast tanks, but urged that someone should analyze the trade-off between reduced scantlings for coatings and plate buckling. A dry-cargo ship owner/operator executive, citing the corrosive environment as different from that on oil tankers, said that there were benefits from coatings. He related the fortuitous situation where some ships originally built with full scantlings were jumboized, yet the plating was adequate when special coating allowances were utilized.

Several interesting comments were received on the subject of weld defects. One inspector for a drill rig owner/operator said that he required about 10% of overall weld footage and 100% of critical area welds to be inspected by non-destructive testing. An executive for an oil tanker company said that at one time the firm investigated the defective welds by X-raying all welds in three ships. The result

was t
one s
analy
owner
quest
made,
conce
is me
of wo

recti
did r
yard
solut
the p

dama
year
have
most
sta
fac
doe
not
at
tol
cur
or
the
stu
des

was that 15% to 20% of the welds X-rayed had some defects. An inspector told of one shipyard's procedure that eliminates the possibility of doing a statistical analysis of weld defects. The yard would not show the "in-process" X-rays to the owner if repairs were required, but would show only the X-rays of the structure in question after repairs were made. The yard evidently felt that if repairs were made, then the original X-rays were irrelevant. This displays a fundamental misconception about NDT as a means of quality control. Since less than 100% sampling is made, it is important to retain and analyze the original data to know what quality of work is being done.

Shipyards and classification societies occasionally have found novel ways of rectifying structural deviations in fit-up. One example involved a bulkhead that did not align with a floor at the tank top. Instead of breaking the connections, the yard welded a large bar to bridge the misalignment. This may seem like a makeshift solution, but it probably did not develop large residual stresses in the joint, as the process of breaking, force-fitting, and rewelding would have (Fig. 4.1).

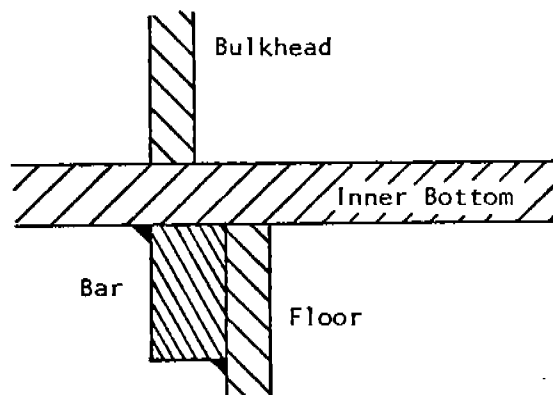

Fig. 4.1: Bulkhead Misalignment

The graph on Figure 4.2, reproduced here with special permission, relates damage occurrence rate to vessel age. The rate rises sharply in the first four years, then falls off to a lower level. The shipping lines interviewed should have seen most of the tolerance-related problems that would show up, by now, since most of their ships were more than four years old. Hence, it would not be fair to state that the lack of information on tolerance-related problems was due to the fact that such problems are just lurking in the ships, waiting to show up. This does not mean that deviations have not caused problems, nor that deviations will not cause problems in later years if such problems have not occurred already. In at least some cases, the statements made by owners/operators regarding lack of tolerance-related structural problems stem from the lack of reporting of such occurrences. Often, cracks or structural failures have been reported as seaway damage or as design problems for which reinforcing was the recommended remedy, when in fact the problem might have been misalignment or faulty welding. Unfortunately for this study, but fortunately for the ships involved, the repairs made to correct suspected design faults usually relieved the problems posed by construction deviations.

Owner/ Oper. Item	# 1		# 2		# 3		# 4		# 5	
	inch	mm	inch	mm	inch	mm	inch	mm	inch	mm
7a Flange Breadth	1/8	3.2								
7b Angle	1/8	3.2								
9a Gap Fillet	t		3/16	4.8					1/4	6.4
9b Butt	min 1/8	3.2			min 1/16	1.6			1/4	6.4
9c Lap	1/16	1.6							0	
10 Beam and Frame Gap	1/8	3.2							0	
11 Butt Misalignment	1/8	3.2	1/8	3.2	1/8	3.2	1/8	3.2	t/2	
12a Reinforcement			1/8	3.2	1/8	3.2				
12b Throat or Leg			-1/16	-1.6	-1/16	-1.6	-1/16	-1.6		
12c Undercut	1/16	1.6	.03	0.8	1/16	1.6	1/16	1.6		
13 Intercostal Misalignment	t/2		t/2		t/2				t/2	
14 Profile Warp			1/8	3.2						
15 Stiffener Bend			1/2	12.7						
16a Butt - Butt Spacing	6	150							6	150
16b Butt - Fillet Spacing	2	51							2	51

TABLE 4.1: Structural Tolerance Standards as Reported by Shipowners/operators

The numerical values of structural tolerances reported by various shipowners/operators are listed in Table 4.1, in both the English units of inches and metric units of millimeters, or in terms of a fraction of the plate thickness. Necessarily, only those tolerance standards supplied by the owners/operators are reported.

As far as deviations on the actual ships built are concerned, very little numerical data was obtained from the owners' representatives at shipyards. Much of this was discussed above along with "in-service" deviations reported. One other source of deviations, "poor detailing of design", was discussed by a few owners/operators. One of them gave a most explicit example involving access ladder rungs. However, this is hardly a structural tolerance problem but concerns more the design of structural details (see Figures 4.3A, B, and C).

4.2 SHIPYARDS AND STEEL FABRICATING FACILITIES

4.2.2 Analysis of Responses to the List of Deviations

The responses obtained from shipyards in the form of numerical data on structural deviations experienced during ship construction and repair activities were quite varied in completeness and depth. Nevertheless, numerical values were accumulated, and these are listed in Table 4.2 both in English and metric units of measurement. It should be noted that the letters on the left hand column of the table reflect the source shipyard and that both deviations and tolerances are listed for each type of imperfection shown across the top of the table wherever such information was furnished.

Where numbers do not appear in Table 4.2, it means that either no information was made available by the yard in question or that the information supplied was descriptive in nature and contained no numerical data. Where reference is seen to AWS, ABS, USCG, NAVSHIPS, Table, Curve, this denotes that, in connection with the structural deviation under which these are listed, the yard in question follows the regulations of the respective regulatory agencies or that the yard has supplied tables or curves to represent the criteria they follow. These are listed and included in Appendix 9.2.

In the tabular listing of deviations and tolerances reported by the shipyards, limited space prevents full explanation of some tolerances. Most listings are straightforward, but the following qualifications are necessary parts of the data from several shipyards.

2. Cutting Line Accuracy

Where $1/8''$ or $1/16''-1/8''$ is listed, $1/16''$ accuracy applies to straight lines and $1/8''$ applies to curved lines.

9a. Gap Before Welding, Fillet Weld

Where $3/16''$ is listed as the tolerance, $0-1/16''$ gap requires the specified weld size, while $1/16''-3/16''$ gap requires an increase in weld size by the quantity (gap- $1/16''$). Also, 2 shipyards require $1/8''$ maximum gap for flat plate and $3/16''$ gap only for curved plate.

11. Butt Joint Misalignment

Where $1/8''$ is listed, it is applicable only to thick plate. The tolerance for thinner plate is as follows:

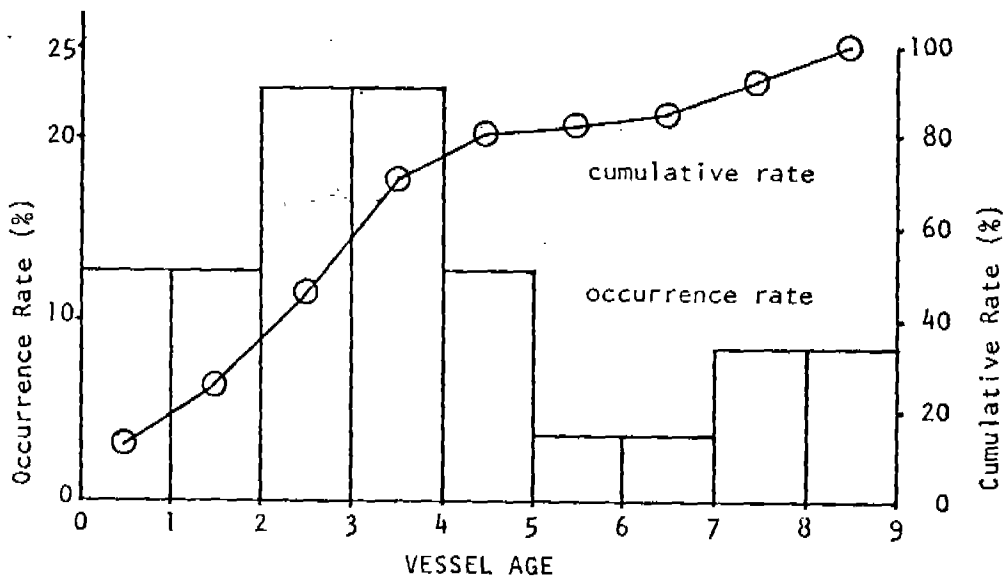

Figure 4.2 Damage Occurrence Rate by Age of Vessel (fatigue failures)

(Source: Reference 20)

Figure 4.3.A Original Requirement

Full penetration welds were not being accomplished, the unsealed outer ends allowed water to enter the joints, and rungs eventually broke loose due to corrosion.

Figure 4.3.B: Full Penetration Weld

Required to keep a hazardous condition from developing. But shipyards objected to this joint.

Figure 4.3.C: As-strong, Easier, and Problem-Free Solution

Shipyards objecting to the full penetration weld claimed that this was equally strong and easier to do. It finally was adopted and served well.

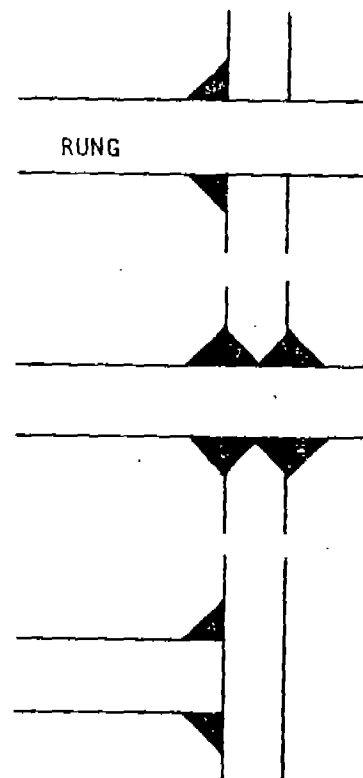

Figure 4.3: Example of Poor Detailing of Design

Tolerance

1/32"

1/16"

1/8"

Plate Thickness

t < 3/8"

3/8" < t < 5/8"

5/8" < t

A quick analysis of the distribution of deviations and tolerances is made in Figs. 4.4 even though it is realized that for most items the number of data points obtained is simply not conducive to a statistical analysis. Even for the small amount of data points however, the representations in Figs 4.4 may still be considered useful in that they report the minimum and maximum values for each item, as well as the ranges. In these representations the hollow bars denote the tolerance limits and the solid bars denote the deviation values reported by the yards.

4.2.2 Review of Structural Tolerances Supplied by Shipyards

A review of Table 4-2 as well as Fig. 4.4 reveals that the situation for tolerance data is slightly better. In a few cases such as the fillet weld gap, butt weld misalignment, butt weld reinforcement, weld undercut, intercostal misalignment, and overall length of the vessel, singular spikes are observed in the graphical representations of Fig. 4.4 in the tolerance frequency distribution. This shows that the majority of shipyards do indeed try to work to the tolerances indicated.

In fourteen cases (3, 7a, 9b, 10, 13, 18, 20, 22a, 22b, 22c, 22d, 23b, 23h, and 23i) the worst deviations lay at least 50% beyond the most liberal tolerances for the same cases. Of these fourteen, the nine underlined were reported by shipyards that had standards for the relevant cases.

A summary of the structural tolerance specifications contained in NAVSHIPS 0900-000-1000, dated 10/68 (4), follows:

8.3.1.1 Fillet Weld Size

0 - 3/8": shall not vary below specified size by more than 1/16" for more than 1/4 of joint length nor for more than 6" at any one location.
7/16" and up: shall not vary below specified size.

12. contains tables of permissible unfairness in welded structure. (See Appendix 9.2.8)

12.1 Butt-type Joints in Plating

Thickness	Maximum deviation allowable
t < 3/8"	1/16"
t > 3/8"	1/8"

14.5.3 Butt Welds in Outer Hull Surface

0 - 1/16" reinforcement (for hydrodynamic reasons).

14.8 Buttering or Buildup

shall not exceed 3/8" thickness on each joint edge.

SHIP YARD	ITEM	1 Receipt Inspection						2 Cutting Line		3 Edge	
		a Waviness		b Thickness & Pits		c Laminations		Accuracy		Preparation	
		inch	mm	inch	mm	inch	mm	inch	mm	inch	mm
A	DEV										
	TOL										
B	DEV										
	TOL			1/8	3.2	AWS 3.2.3.1	1/8	3.2	ABS 30.3.1		
C	DEV										
	TOL						1/4	6.4			
D	DEV										
	TOL										
E	DEV										
	TOL			.1t			1/8	3.2			
F	DEV										
	TOL						3/16	4.8			
G	DEV										
	TOL						1/8	3.2	1/64-	.4 - .8	
H	DEV	1/8	3.2	1/8	3.2		1/8	3.2	1/16-1/8	1.6	
	TOL	1/32	0.8	1/32	0.8		1/4	6.4	1/8	3.2	
I	DEV										
	TOL	1"	25.4								
K	DEV										
	TOL	Table		1/64	0.4	3/8	9.5				
L	DEV								3/16	.5	
	TOL						1/16	1.6	1/8	3.2	
M	DEV										
	TOL										
N	DEV										
	TOL										
O	DEV										
	TOL										
P	DEV										
	TOL										
Q	DEV						1/8	3.2			
	TOL			1/8	3.2		1/8	3.2	1/16	1.6	
R	DEV										
	TOL								1/8	3.2	
S	DEV										
	TOL					Table					

SHIP YARD	ITEM
A	DEV
	TOL
B	DEV
	TOL
C	DEV
	TOL
D	DEV
	TOL
E	DEV
	TOL
F	DEV
	TOL
G	DEV
	TOL
H	DEV
	TOL
I	DEV
	TOL
K	DEV
	TOL
L	DEV
	TOL
M	DEV
	TOL
N	DEV
	TOL
O	DEV
	TOL
P	DEV
	TOL
Q	DEV
	TOL
R	DEV
	TOL
S	DEV
	TOL

TABLE 4.2: Deviations and Tolerances at Shipyards

SHIP YARD	ITEM	4 Edge Straightness						5 Groove Depth		6 Taper Angle	
		a Automatic Welding		b Semi-automatic		c Manual		Depth		Taper Angle	
		inch	mm	inch	mm	inch	mm	inch	mm	inch	mm
A	DEV										
	TOL										
B	DEV										
	TOL									± 7°	
C	DEV										
	TOL										
D	DEV										
	TOL										
E	DEV										
	TOL	1/8	3.2								
F	DEV	1/8	3.2	1/8	3.2	1/8	3.2	1/32	0.8	±2°	
	TOL										
G	DEV							0-1/8	3.2	±5°	
	TOL	3/16	4.8	3/16	4.8	3/16	4.8	3/16	4.8	±8°	
H	DEV	1/8	3.2	1/8	3.2	1/8	3.2	1/8	3.2		
	TOL	1/16	1.6	1/16	1.6	1/16	1.6	1/16	1.6		
I	DEV										
	TOL										
K	DEV										
	TOL							0-3/16	4.8		
L	DEV										
	TOL	1/32	0.8	1/16	1.6	3/32	2.4	0-1/8	3.2	±5°	
M	DEV										
	TOL										
N	DEV										
	TOL										
O	DEV										
	TOL										
P	DEV										
	TOL										
Q	DEV	1/8	3.2	3/16	4.8	1/4	6.4	1/16	1.6	5/64	2.0
	TOL	1/16	1.6	1/8	3.2	1/8	3.2	3/32	2.4	3/32	2.4
R	DEV										
	TOL										
S	DEV										
	TOL										

TABLE 4.2: Continued

ITEM SHIP YARD	Fabricated Shapes										8	
	a Flange Breadth		b Flange Angle		c(i) Straightness				c(ii)		Rolled Shape Flange Angle	
	inch	mm	inch	mm	Flange Plane		Web Plane		inch	mm	inch	mm
A DEV												
TOL												
B DEV												
TOL	±1/4	6.4	±1.5°								1.5°	
C DEV												
TOL	1/8	3.2	±1/4	6.4								
D DEV												
TOL												
E DEV												
TOL			±2°								2°	
F DEV	1/8	3.2			1/4	6.4	1/4	6.4				
TOL												
G DEV	1	25.4	±1°		1/4	6.4					2°	
TOL			±3°		1/4 ^{10'}	6.4					2°	
H DEV					1/2 ^{3'}	12.7	1/2	12.7			3/4t	
TOL					3/8 ^{3'}	9.5	3/8	9.5			t/2	
I DEV	1/8	3.2										
TOL												
K DEV												
TOL	1/8	3.2	1/4	6.4	1/8 ^{10'}	3.2	1/8	3.2	1/4	6.4		
L DEV												
TOL			±1.5°		1/8	3.2	1/8	3.2	2°			
M DEV	1/4	6.4										
TOL												
N DEV												
TOL												
O DEV												
TOL												
P DEV												
TOL			±1/2	12.7								
Q DEV	1/8	3.2	1/8 ^{4"}	3.2	1/8 ^{30'}	3.2	1/8 ^{30'}	3.2				
TOL	3/16	4.8	3/16 ^{4"}	4.8	3/16 ^{30'}	4.8	3/16 ^{30'}	4.8	3/8	9.5		
R DEV												
TOL												
S DEV												
TOL												

ITEM SHIP YARD	DEV	TOL
A	DEV	TOL
B	DEV	TOL
C	DEV	TOL
D	DEV	TOL
E	DEV	TOL
F	DEV	TOL
G	DEV	TOL
H	DEV	TOL
I	DEV	TOL
K	DEV	TOL
L	DEV	TOL
M	DEV	TOL
N	DEV	TOL
O	DEV	TOL
P	DEV	TOL
Q	DEV	TOL
R	DEV	TOL
S	DEV	TOL

TABLE 4.2: Continued

ITEM SHIP YARD	12 a Reinforcement		Weld Geometry Throat ^D or Leg		c Undercut		13 Intercostal Misalignment		14 Profile Warp	
	inch	mm	inch	mm	inch	mm	inch	mm	inch	mm
A DEV										
TOL										
B DEV										
TOL	1/8	3.2	+1/16	1.6	1/32	0.8	t/4-t/2			
C DEV							t/4			
TOL					1/16	1.6	t/2	1/8"	3.2	
D DEV					1/32	0.8				
TOL										
E DEV							t/2			
TOL										
F DEV							t/2	3/8	9.5	
TOL							3"	76.		
G DEV							t			
TOL	1/8 max	3.2					t/2		2° max.	
H DEV							t		2°	
TOL	1/32	0.8	-1/32.+1/8	-0.8	1/32	0.8				
I DEV			+1/32	0.8			t/2			
TOL			1/8	3.2			t/2			
K DEV							t/2			
TOL							1/2"	12.7		
L DEV					1/32 max	0.8	t/2			
TOL							3/4"	19.1		
M DEV					1/32	0.8	t/2			
TOL										
N DEV					1/32 max	0.8	t/2			
TOL							1"	25.4		
O DEV										
TOL										
P DEV										
TOL	1/32-1/8	0.8-			1/32	0.8	t/2			
Q DEV	1/16-3/32	1.6-								
TOL	1/8	3.2			1/16	1.6	t/2	1/8"/6"	3.2	
R DEV										
TOL	1/32-1/8	0.8-	+1/16	1.6	1/32	0.8	t/2			
S DEV										
TOL					1/16	1.6	t/2			

TABLE 4.2: Continued

K
S
Y.
A
B
C
D
E
F
G
H
I
K
L
M
N
O
P
Q
R
S
TO
DE
TC
DE
TC
DE
TO
DE
TO

SHIP YARD	ITEM	19 Subassembly Accuracy b				20 Hatch Coaming		21 a Access Openings b			
		Length a and Width		Squareness		Dimensions		Dimensions		Deformation	
		inch	mm	inch	mm	inch	mm	inch	mm	inch	mm
A	DEV										
	TOL										
B	DEV										
	TOL	1/8	3.2	7/8	22.2						
C	DEV										
	TOL			1/4	6.4						
D	DEV										
	TOL										
E	DEV	1/4	6.4	1/2	12.7						
	TOL	.1%		1/4	6.4						
F	DEV	1/2	12.7	1/2	12.7			3/32	2.4	3/32	2.4
	TOL										
G	DEV					.1%		1/2	12.7		
	TOL	3/16	4.8	1/4	6.4	.1%		1/2	12.7		
H	DEV										
	TOL	1/4	6.4	1/4	6.4	1/4	6.4	1/8	3.2	1/8	3.2
I	DEV										
	TOL										
K	DEV										
	TOL			1/4	6.4						
L	DEV	3/16	4.8								
	TOL										
M	DEV										
	TOL										
N	DEV										
	TOL	1/4	6.4	1/8	3.2						
O	DEV										
	TOL										
P	DEV					1/2	12.7				
	TOL	1/2	12.7	3/4	19.1						
Q	DEV										
	TOL	1/4	6.4	5/16	8.0	1/4	6.4	USCG		USCG	
R	DEV										
	TOL										
S	DEV										
	TOL										

SHIP YARD	ITEM
A	
B	
C	
D	
E	
F	
G	
H	
I	
K	
L	
M	
N	
O	
P	
Q	
R	
S	

TABLE 4.2: Continued

ation
mm
2.4
3.2

ITEM SHIP YARD	22 a		b		c		d	
	Bottom Shell		Unfairness Side Shell		Deck Plate		Superstructure Sides and Ends	
	inch	mm	inch	mm	inch	mm	inch	mm
A DEV								
TOL								
B DEV								
TOL	3/8t		3/8t		t/2		t/2	
C DEV								
TOL								
D DEV								
TOL								
E DEV			3/4	19.1				
TOL	Curves		Curves		Curves		Curves	
F DEV								
TOL	1/16	1.6	1/16	1.6	1/16	1.6		
G DEV								
TOL	1/4"/3'	6.4	1/4	6.4	1/4	6.4	1/4	6.4
H DEV	1-1/2	38.	1-1/4t		1"	25.4	3/4	19.1
TOL	t/6'		t		1/2"/3'	12.7	1/2	12.7
I DEV	5/8	15.9						
TOL	3/4	19.1						
K DEV			1/4	6.4				
TOL	Curves		Curves		Curves		Curves	
L DEV								
TOL	Table		Table		Table		Table	
M DEV								
TOL	5/16	8.0						
N DEV								
TOL								
O DEV								
TOL	NAVSHIPS							
P DEV								
TOL								
Q DEV								
TOL	3/8"/30"	9.5	3/8"/30"	9.5	3/8"/30"	9.5	3/8"/30"	9.5
R DEV								
TOL								
S DEV								
TOL	1/8	3.2	1/8	3.2	1/8	3.2		

TABLE 4.2: Continued

SHIP YARD	ITEM	23 Overall Dimensions											
		a Length		b Beam		c Depth		d Keel Flatness		e Forebody Rise			
		inch	mm	inch	mm	inch	mm	inch	mm	inch	mm		
A	DEV	-2-1/4	-57.										
	TOL												
B	DEV												
	TOL	1	25.4			1/4	6.4						
C	DEV												
	TOL												
D	DEV												
	TOL												
E	DEV	±2	51.	±2	51	1-1/2	38.			5/8	15.9		
	TOL	.1%				1/2	12.7	1	25.4				
F	DEV	.1%		.1%		.1%							
	TOL												
G	DEV	.1%											
	TOL	.1%		.1%		.1%		.1%		1/4"/25'	6.4		
H	DEV												
	TOL	1/2	12.7	1/2	12.7	1/2	12.7	2t					
I	DEV	7-1/2	191.			5/8	15.9						
	TOL	.1%											
K	DEV												
	TOL	.1%		1	25.4	1	25.4						
L	DEV	+4	102.			1/2	12.7						
	TOL	.1%				3/8	9.5						
M	DEV												
	TOL												
N	DEV												
	TOL	.1%											
O	DEV												
	TOL												
P	DEV	1-1/4	32.	1/2	12.7	5/8	15.9	5/8	15.9				
	TOL	.1%		1/2	12.7					1/2	12.7		
Q	DEV									1/2	12.7		
	TOL	3"	76.	1/2"	12.7	1/2"	12.7	1"	25.4	3/4	19.1		
R	DEV												
	TOL												
S	DEV			-4	102.								
	TOL	.1%						1	25.4				

TABLE 4.2: Continued

SHIP YARD	ITEM
A	A
B	B
C	C
D	D
E	E
F	F
G	G
H	H
I	I
K	K
L	L
M	M
N	N
O	O
P	P
Q	Q
R	R
S	S

SHIP YARD	ITEM	23 f Overall Dimensions				g		h		i	
		Afterbody		Deadrise		Draft		Freeboard			
		Rise				Marks		Marks			
		inch	mm	inch	mm	inch	mm	inch	mm		
A	DEV										
	TOL										
B	DEV										
	TOL										
C	DEV					1/16	1.6	1/16	1.6		
	TOL										
D	DEV										
	TOL										
E	DEV										
	TOL					1/8	3.2				
F	DEV					1/8	3.2				
	TOL										
G	DEV										
	TOL	1/4"/25'	6.4	.1%							
H	DEV					1/2	12.7	1/4	6.4		
	TOL					1/4	6.4	1/8	3.2		
I	DEV										
	TOL										
K	DEV										
	TOL					1/16	1.6				
L	DEV	2	51.	3/8	9.5						
	TOL										
M	DEV										
	TOL										
N	DEV										
	TOL										
O	DEV										
	TOL					1/4	6.4				
P	DEV					1/8	3.2	1/8	3.2		
	TOL										
Q	DEV	1/2	12.7	1/2	12.7	1/16	1.6	1/16	1.6		
	TOL	3/4	19.1	5/8	15.9	3/32	2.4	3/32	2.4		
R	DEV										
	TOL										
S	DEV										
	TOL										

TABLE 4.2: Continued

LEGEND

Abscissae: As indicated
 Ordinates: Number of Data Points
 Solid Bar: Deviation
 Hollow Bar: Tolerance Limit

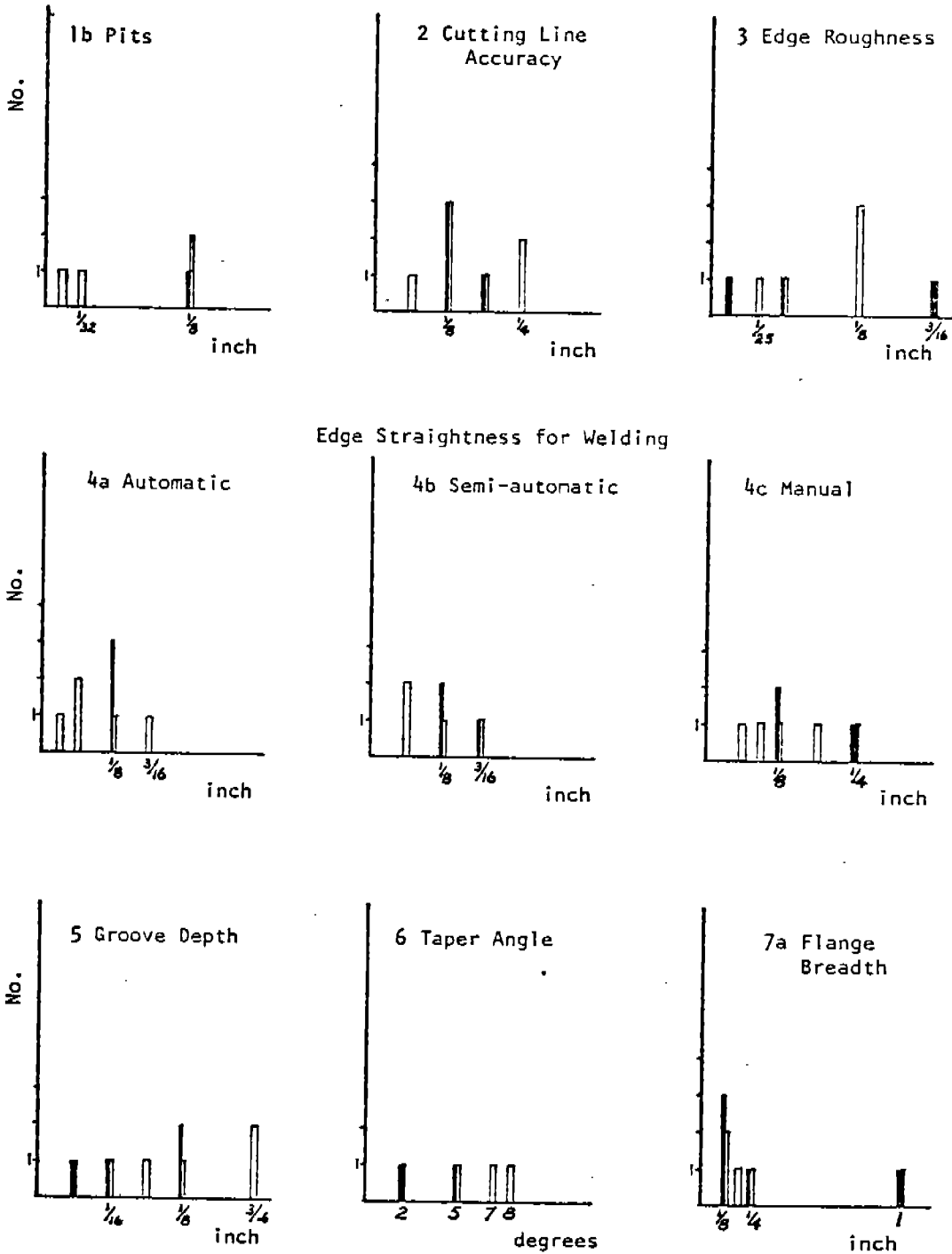

Fig. 4.4: Graphical Representation of Reported Structural Deviations and Tolerances

LEGEND

Abscissae: As indicated
 Ordinates: Number of Data Points
 Solid Bar: Deviation
 Hollow Bar: Tolerance Limit

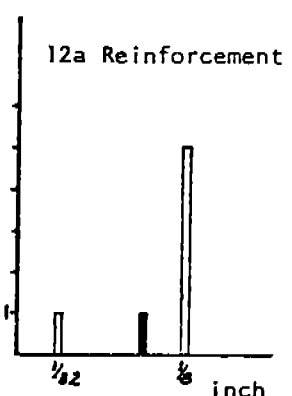
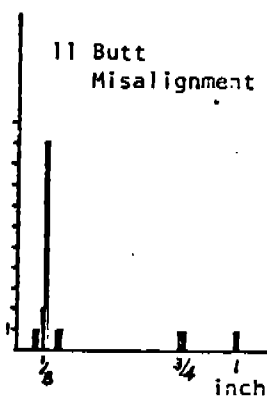
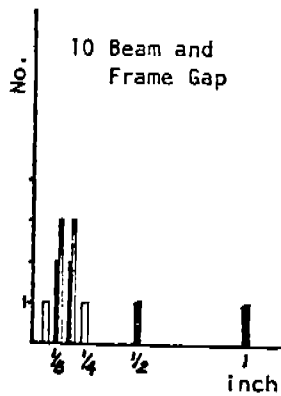
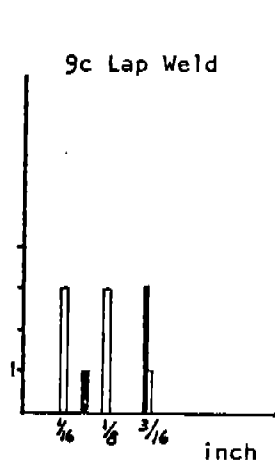
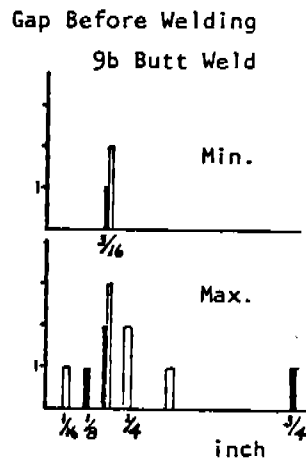
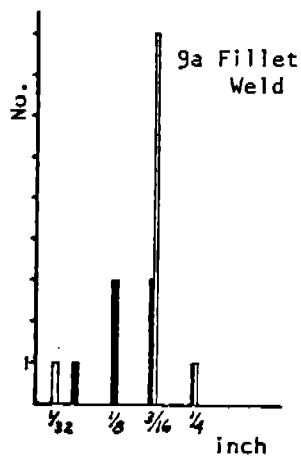
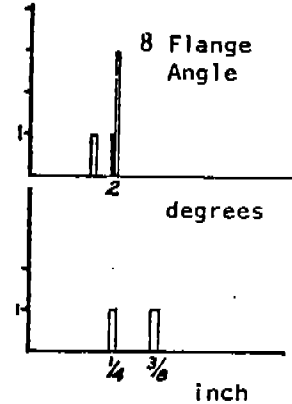
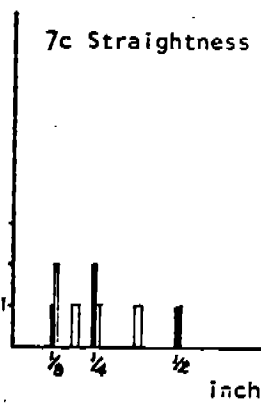
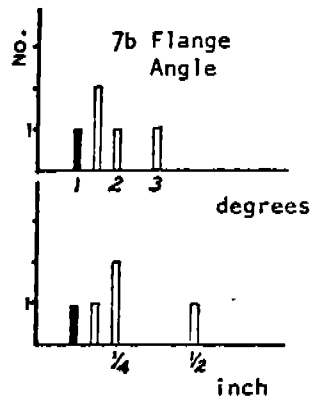

Fig. 4.4: Continued

LEGEND

Abcissae: As indicated
 Ordinates: Number of Data Points
 Solid Bar: Deviation
 Hollow Bar: Tolerance Limit

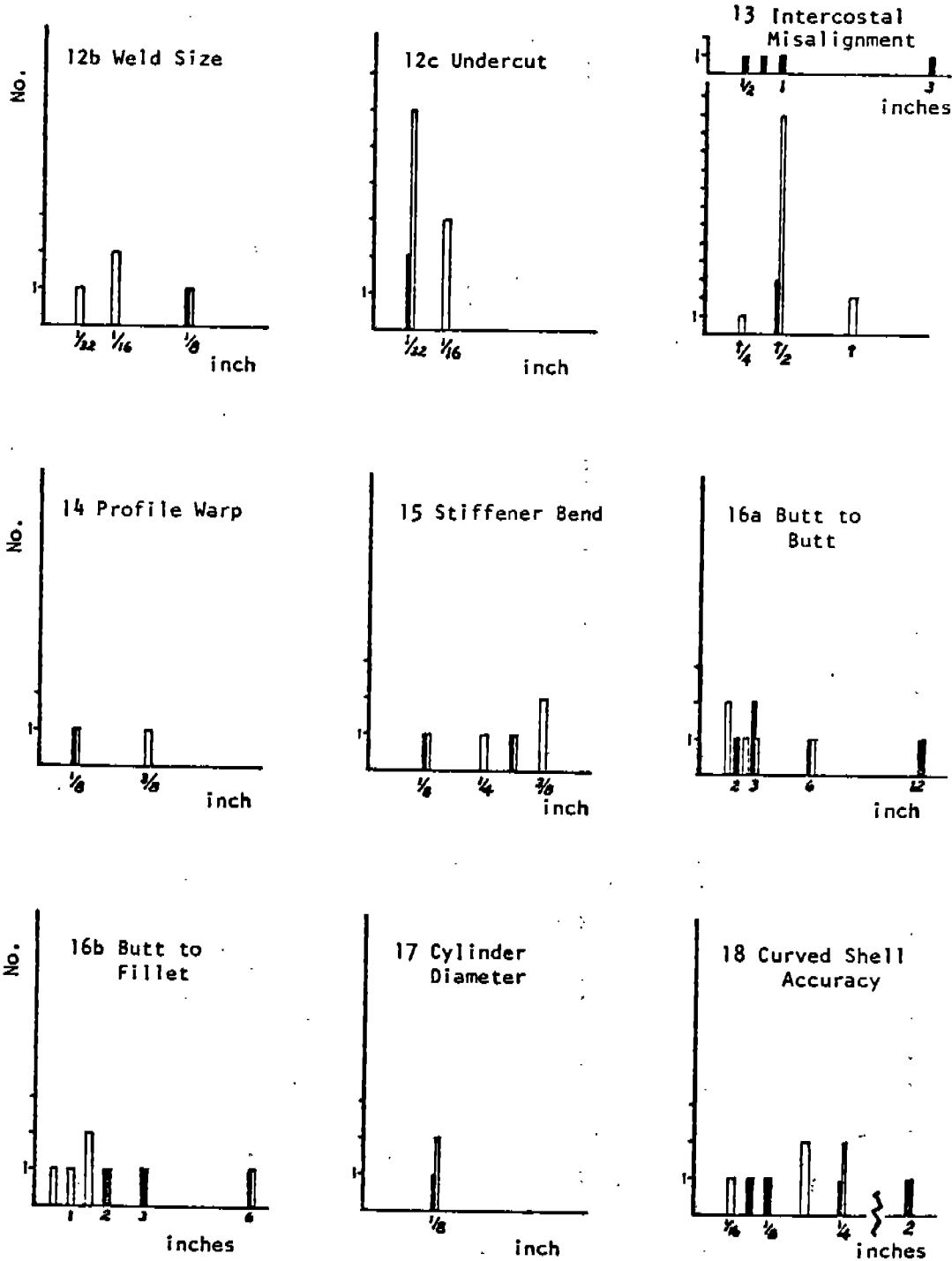

Fig. 4.4: Continued

LEGEND

Abcissae: As indicated
 Ordinates: Number of Data Points
 Solid Bar: Deviation
 Hollow Bar: Tolerance Limit

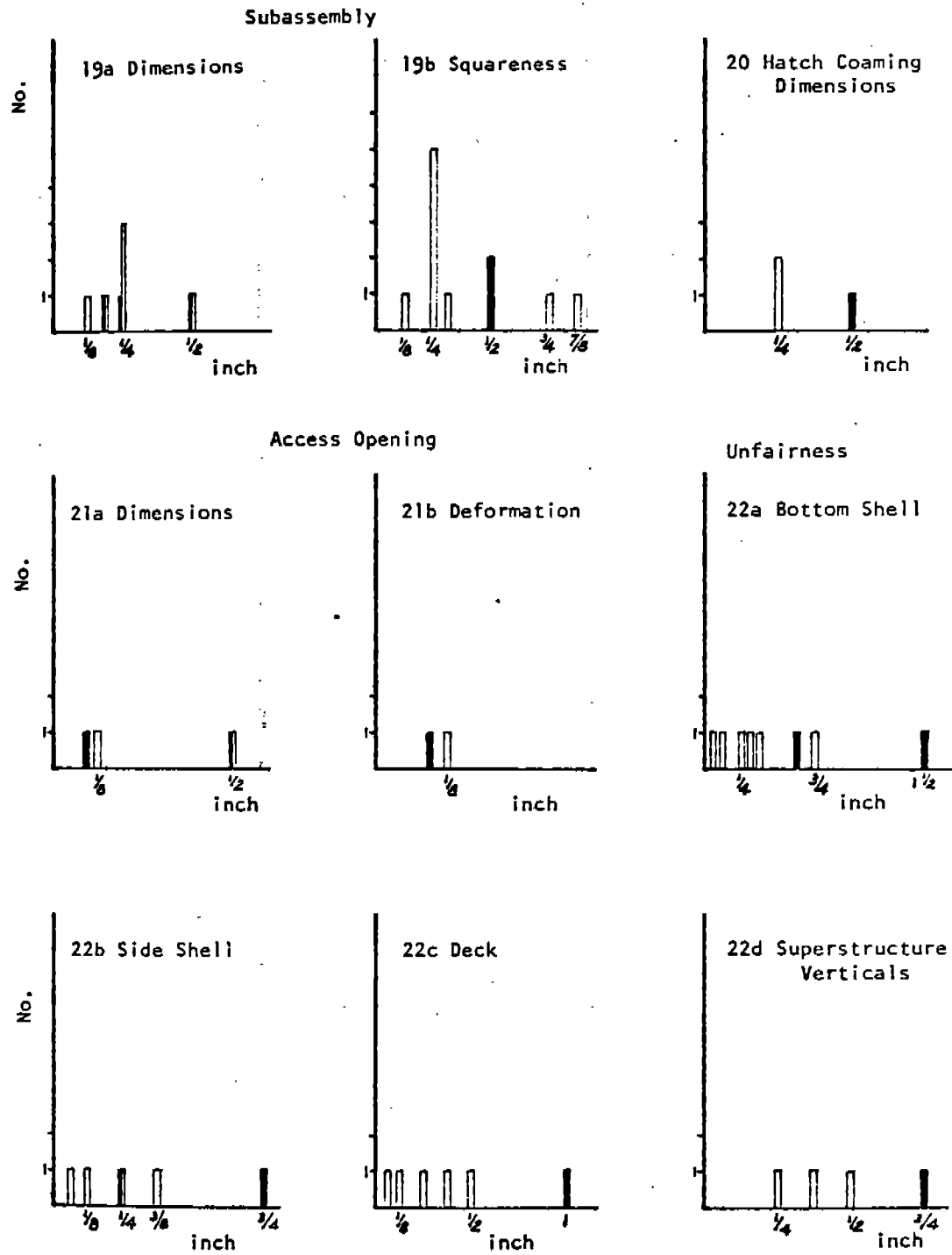

Fig. 4.4: Continued

LEGEND

Abscissae: As indicated
 Ordinates: Number of Data Points
 Solid Bar: Deviation
 Hollow Bar: Tolerance Limit

23 Overall Dimensions

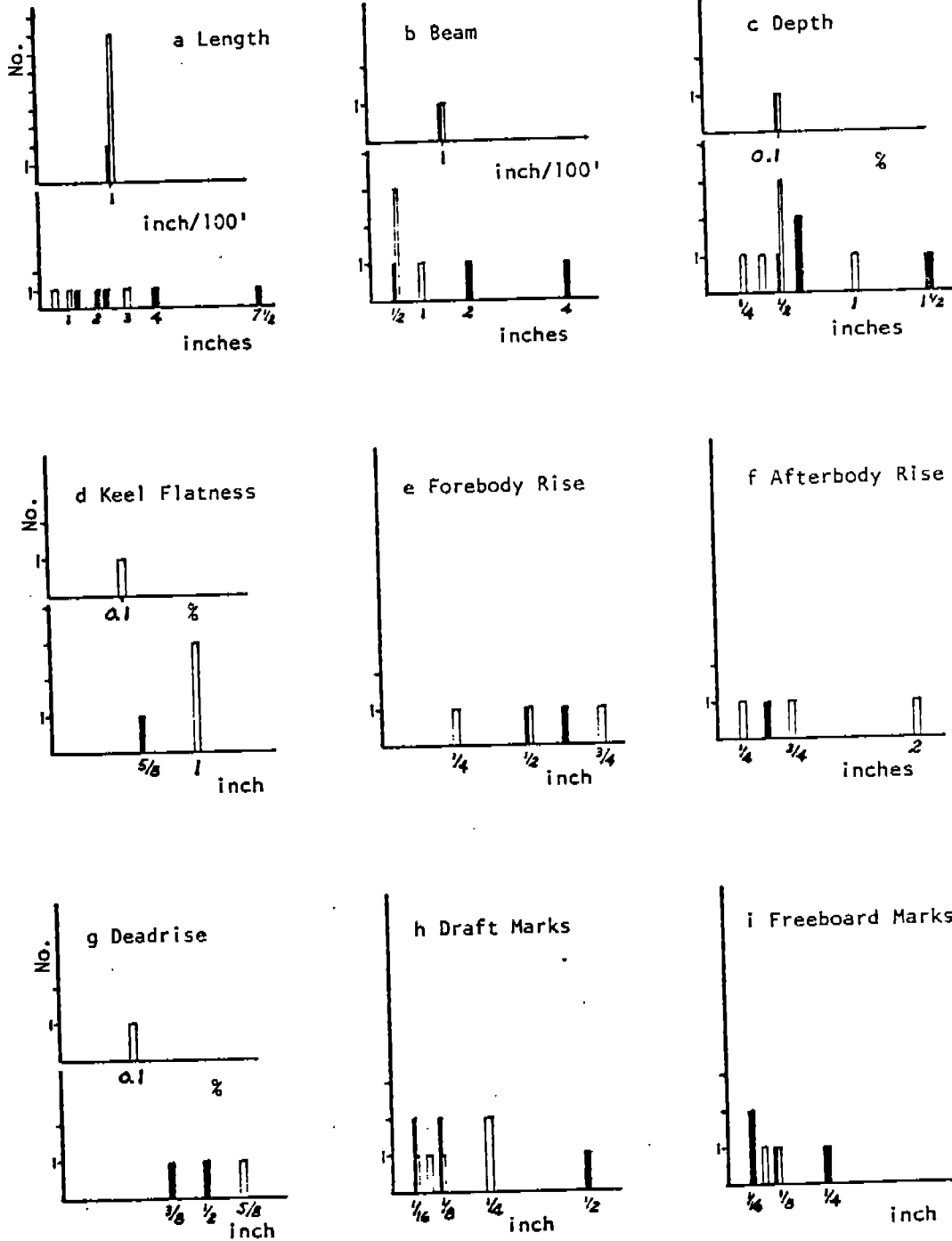

Fig. 4.4: Continued

These standards, except for the tables in their section 12, are quite similar to the American Bureau of Shipping requirements as set forth in the Rules for Building and Classing Steel Vessels (12), (see Appendix 9.2).

Most yards follow some sort of tolerance standards as far as the unfairness of plating and misalignment of intercostal members are concerned. For the remaining structural deviations, very few yards have established written standards, except for the following, whose standards are reproduced with special permission in Appendix 9.2:

Bath Iron Works Corporation
Litton Industries Ingalls Shipbuilding Division
Levingston Shipbuilding Corporation
Newport News Shipbuilding & Dry Dock Corporation
Seatrain Shipbuilding Corporation
Sun Shipbuilding & Dry Dock Company

4.3 STEEL MILLS

Two steel producers surveyed were presently meeting and sometimes even exceeding the ABS requirements for materials.

4.3.1 General

The ABS "Rules for Building and Classing Steel Vessels" has an entire chapter (Section 43, Materials for Hull Construction and Equipment) in which specific requirements for mill practices and tests are given. The process of manufacture probably is most important to the ABS. Chemical composition, including ladle analysis, product analysis, and fine grain analysis (when applicable), is monitored at the mill by the Surveyor. Subsequent heat treatment at the mill or at the shipyard also is monitored by the Surveyor. For each "heat", tension tests on carefully selected specimens are performed. Material for castings and forgings is subject to bend tests. Grade D, E, DH, and EH materials are subject to impact tests.

No measurements are required by the ABS for plate or shape dimensions. These measurements are supposed to be handled by the mills themselves, under the American Institute of Steel Construction Specification, the American Society for Testing Materials standards, and the American Iron and Steel Institute rules.

AISC's section on Standard Mill Practice is a summary of the ASTM Designation A6, which itself is a group of common requirements for rolled steel plates and shapes:

- " a. Plates are to be checked for thickness and weight, width and length, camber and flatness.
- b. Structural-size shapes are limited to 2.5% variation from theoretical cross-section area or weight, and dimensions are to be checked for variations in cross-section, ends out of square, straightness, and length."

ASTM permits 1/4 inch variation under ordered length and width.

4.3.2 Results of Surveys at Mills

Both steel mills stated that they work basically to the standard tolerances of the AISC (American Institute of Steel Construction), ASTM (American Society for Testing Materials) and AISI (American Iron and Steel Institute). Closer tolerances are generally observed for alloy and higher strength steels, particularly armor plate and steel for nuclear plants. One mill said they can work to 1/2 standard tolerances or any other tolerance level required by the purchaser but at extra cost.

The following numerical values for actual deviations experienced on steel material produced were furnished by one mill:

- a. The allowance for thickness during the rolling process is generally about 10 mils over on the edge of the plate, so that when the plate cools, the thickness will be closer to the nominal value.
- b. For a nominal plate thickness of 1/4", the variance on the finished product will be .238" to .255". On the average, the finished plate is 3 to 4% overweight from the standpoint of thickness.
- c. Plates, after torch-cutting and when they are ready for shipment, are approximately 5% overweight from an overall viewpoint, i.e., considering both their thickness and size against nominal values.
- d. Laminations are occasionally found on rolled plates. It was stated that the laminations could never be totally eliminated; however, they are reduced to less than 1/2% of the plate production. Frequency of finding laminations depends on the thickness of the plate.
- e. Corrosion and pitting also may be present. However, the more serious problems are scabs, slivers, etc., which require conditioning of the plate by grinding. Alloy steels are subjected to a greater degree of conditioning.

4.4 CLASSIFICATION SOCIETIES

4.4.1 General

The American Bureau of Shipping is the dominant classification society for building in United States yards. The U.S. Coast Guard accepts the current standards established by the ABS and designated "Rules for Building and Classing Steel Vessels" regarding material and construction of hulls, boilers, and machinery, except that their standards generally are compared to ABS standards to determine their acceptability by the Coast Guard.

Specific parts of the ABS rules are excerpted below:

- " 24. Vessels Intended to Carry Liquified Gases
- 24.27 Non-destructive Testing

All butts and seams of welded primary containers for cargoes at -73°C (-100°F) or colder are to be completely radiographed unless they are tested by an alternate approved procedure for nondestructive testing. The butts and seams of welded primary containers for cargoes above -73°C are to be radiographed at all intersections and at random locations of the butts and seams to the satisfaction of the attending Surveyor. The method of nondestructive testing of nonstructural primary containers or secondary barriers is to be specially considered.

30. Welding

30.3.1 Edge Preparation and Fitting

Weld build up should not exceed $t/2$ or $1/2''$ ($12/5$ mm) on each plate edge.

Where sections to be joined differ in thickness and have an offset on any side of more than $1/8''$ (3 mm), a transition having a length not less than three times the offset is to be provided. The transition may be formed by tapering the thicker plate or by specifying a weld joint design which will provide the required transition.

30.3.3 Cleanliness

Slag and scale are to be removed not only from the edges to be welded but also from each pass or layer before the deposition of subsequent passes or layers.

30.5.7 Fairing and Flame Shrinkage

Fairing by heating or flame shrinking and other methods of correcting distortion or defective workmanship in fabrication of main strength members within the midships portion of the vessel and other plating which may be subject to high stresses is to be carried out only with the express approval of the Surveyor.

30.5.9 Inspection of Welds

Radiographic or ultrasonic inspection or both is to be used when the overall soundness of the weld cross section is to be evaluated. Magnetic particle or dye-penetrant inspection or both is to be used when investigating the outer surface of welds or may be used to check back chipped, ground or gouged joints prior to depositing subsequent passes. Some steels, especially higher-strength steels, exhibit a tendency to delayed cracking. When welding these materials, consideration is to be given to delaying the final nondestructive testing to accommodate occurrence and detection of such defects.

30.9 Fillet Welds

30.9.1 General

The weld throat size t is not to be less than 0.7 times the weld leg size w . Where the gap between the faying surfaces of members exceeds 2 mm or 1/16" and is not greater than 5 mm (3/16") the weld leg size is to be increased by the amount of the opening. The gap between members is not to be greater than 5 mm (3/16"). "

4.2.2 Results from Classification Societies

a. American Bureau of Shipping (ABS)

ABS cited a structural detail where a plate was being welded to another plate situated perpendicular to the first plate. At first, the vertical plate was welded to the horizontal plate by a full penetration weld from the top and by a fillet weld from the bottom. (See Fig. 4.5A). In this configuration the vertical plate had a tendency to crack at about the middle of it. In one case where this happened, the plate was thought to be deficient and a new plate was fitted and welded in the same manner, and sure enough, the same crack occurred. It was then decided that the reason for this crack was not a deficiency of the plate itself, but rather, a result of the shrinkage of the full penetration weld. To prevent this, the configuration shown in Fig. 4.5B was used with success. This sort of failure was perhaps justly called "lamellar tearing"; however, the reason for failure was not the plate deficiency, but the shrinkage of weld. The same type of failure was seen to occur in the case of explosion bonding of aluminum to steel, however this detail is usually located in areas above the main deck level so that there is only a compressive loading on the explosion-bonded joint and the compressive force will not present any danger to these normally failure-prone areas (see Fig. 4.5C). It follows, therefore, that no remedial action is necessary.

ABS allows mill tolerances on the minus side. However, when it comes to the owner's tolerances they do not allow this because this would cause a loss in the corrosion allowance for the owner.

b. Bureau Veritas (BV)

BV has no published standards for tolerances, however, they do have a compilation which is reportedly treated as confidential.

BV has another publication, in addition to the "Rules", which is titled "Instructions for Surveys of New Construction Steel Vessels" which also is confidential. This publication does not include tolerances in the form of a tabulation, but gives some guidelines.

BV had statistical information on actually measured tolerances on ships built in French yards, but they would not release this information due to insurance premium complications.

c. Nippon Kaiji Kyokai (NK)

NK does have a set of standards on ship structural tolerances "Japanese Shipbuilding Quality Standards - Hull Part" (2) and the most recent edition is dated 1975.

LAMELLAR
TEARING

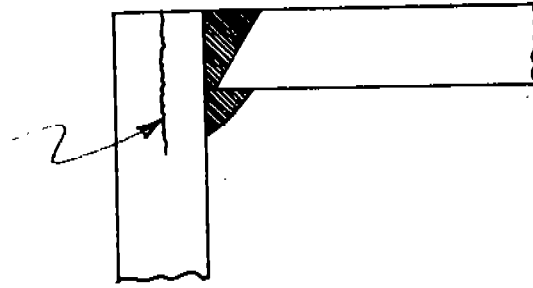

Fig. 4.5A: Full Penetration Weld

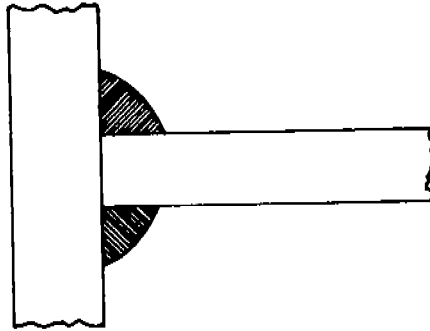

Fig. 4.5B: Alternate Detail

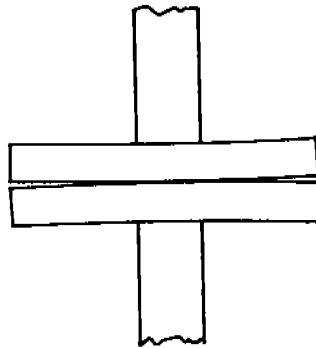

Fig. 4.5C: Explosion Bonding

NK has based these standards on a large research effort conducted by the Society of Naval Architects of Japan (SNJ) in a number of Japanese shipyards. Deviations were actually measured on many structures, histograms of deviations were made and from these the standard ranges and maximum tolerance levels were established for each and every structural deviation. The results of this full-scale effort is published by SNJ in the Japanese language. One chapter of this publication, Chapter IX, is included in Appendix 9.3.

NK X-ray examination for the hull envelope of the ship, including strength deck and the shell plating and the number of X-rays are established on a random sampling method and the maximum number is about 150, depending on the length of the ship; this number can be reduced to 100. However, the actual number of X-rays to be taken on any one ship depends on the accuracy of the results obtained from the X-rays already performed. If some of the results are not satisfactory, then this number can be increased.

The NK criteria to accept or reject a weld, perform visual examinations of the welds, and evaluate X-rays of the welds, follow the Japanese industrial standards methods. The butt welds in the vertical areas, the faceplates of frames, beams and girders are required almost exclusively to be X-rayed. However, when the physical location of any faceplate or flange or girder makes it difficult to X-ray, then UTS may be substituted, depending on the aforementioned conditions.

d. Lloyds Register of Shipping (LR)

LR has periodicals and papers that are published for the purpose of delegating senior surveyors' experiences to other surveyors in the staff. They have another publication, "Instructions to Surveyors" (confidential) which treats structures, deviations, and methods of repair.

LR has accumulated a great deal of statistical data on failures of and damages to ships since 1942. Also included in this accumulation is an analysis of the failure and the methods of repair. This information is fed into a computer program and the data are processed and evaluated for future reference.

e. Det norske Veritas (DnV)

DnV cited their Rules, Chapter I, Section 6C; Chapter II, Section 3E; and Chapter X, Section 3A, as being applicable to workmanship, minimum tolerances, and repair of defects. These sections were found to be written in general terms, no more specific than similar specifications by other classification societies.

f. Registro Italiano Navale (RIN)

RIN excerpted the RINA rules on structural steels, welding (processes, joints and edge preparation, workmanship, NDT, and repairs), special welding processes, hull structures (material, welding, repairs, and inspection), design and fabrication of welded structures, and control procedures for weld defects and included recommendations for fit-up alignment, deflection, straightening practice, welding flaws, flaws in base material and thickness variations. Research papers on quality standard/quality control and NDT of shipboard welds, especially with UTS, were appended (8,26).

4.5 FOREIGN INSTITUTIONS

The Association of the German Shipbuilding Industry (Verband der Deutschen Schiffbau-Industrie e.V.) supplied the "Production Standard of the German Shipbuilding Industry" (15), (Appendix 9.3.2). A number of West German yards worked in preparing this standard. It is being revised continually, and contains, as of this date, the following subjects:

1. Surface defects and laminations
2. Edge Preparation
3. Welds
4. Component part fabrication
5. Sub-assembly
6. Fairing work
7. Final work
8. Tightness test
9. Hull-main dimensions

The Swedish Shipbuilding Standards Center (Varvsindustrins Standardcentral) supplied VIS 530, Accuracy in Hull Construction (16).

The Kochums Mekaniska Verkstads AB laboratory provided a paper on fillet welds (17) as compared to full penetration welds. No other papers were available in English translations.

The British Ship Research Association has recently commenced collecting information on structural tolerances, on behalf of the British industry under a government supported project, Advanced Shipbuilding Technology (ATS).

4.6 OVERVIEW

A complete review of all data and documents accumulated in the course of surveys and interviews shows that it is possible to identify widely used values in connection with most of the structural deviations listed in Section 3. Using the same numbering system for various deviations, the most widely used values in United States shipyards appear to be as follows:

1. Pits in incoming material, up to 1/16" (1.6mm) are normally ground smooth. Deeper pits up to 1/8" (3.2mm) or perhaps slightly larger are filled with weld and then ground smooth. In thick material, 1" or more, deeper pits may be tolerable in mild steel. However, a large number of pits (deeper than 1/8") in incoming material are considered reason for rejection. In some instances, deep pits may be repaired in accordance with section 43.3.7 (b) of ABS Rules.
2. Cutting Line Accuracy is greatly dependent on shop equipment and controls. Deviations up to 3/16" (4.8mm) is not uncommon, and this appears to be the presently identifiable United States shipyard practice.

3. The range of edge preparation tolerances found in the surveys is large, running from .04 inches to .125 inches. This indicates that the tolerance is more a function of the plate cutting equipment than of the necessity of obtaining satisfactory welds. Shipyards that use relatively crude flame-cutting equipment, or which allow cutting in place after mounting material on the ship, may have to accept an edge roughness of up to 1/8". Yards that use the newer plasma-arc cutting equipment may be able to achieve edge roughness as low as 1/25".

4. Edge Straightness affects the care that must be taken to ensure that good welds are made. As the degree of automation in welding procedure increases, so does the need for edge straightness. Otherwise, manual control of automatic welding machines is necessary to produce uniform welds if the groove varies in width and wanders from side to side of the machine's track. Such manual control would defeat a major purpose of having automatic welding machines: labor reduction. For manual welding the United States practice seems to be $\pm 1/8"$ (3.2mm), and for automated welding it is in the order of $\pm 1/16"$ (1.6mm) or better.

5,6 Groove Depth and Taper Angle, values most commonly found are $\pm 1/8"$ (3.2mm) and $\pm 5^\circ$ respectively.

7. Flange Breadth and Angle on Fabricated Shapes are important where the shapes must pass through bulkheads or floors, especially when the intersections are to be made watertight. Tight tolerances reduce the amount of field work to make inserts fit and to weld the intersections. These two dimensions also are important where shapes must be butt welded at their ends. The representative values appear to be:

a. Flange Breadth: $\pm 1/4"$ (6.4mm).

b. Flange Angle: $\pm 1/4"/10'$ (6.4mm/3m) or $\pm 1.5^\circ$

c. Straightness of Fabricated Shapes is dependent on assembly procedure. If adequate allowance is made for adjusting before welding, this is not critical. But if force-fitting must be done to a shape, with consequent residual stresses which will be high because the section modulus is high both for x-x and y-y axes, then straightness is critical, and the most widely used limit in such cases appears to be better than t/2 bend over the length.

for 1a

(0.8mm
made t
any un
equipm

subject
appear

tes
ip-
ship-
ch

8. The attainable level for the Flange Angle of Rolled Shapes appears to be the same as for fabricated shapes, $\pm 1.5^{\circ}$.
9. Gap Before Welding is dependent on Cutting Line Accuracy. Enough information exists in literature on the treatment for various gap sizes and welding techniques.
10. Beam and Frame Gap is similar to the problem of fabricated shape straightness. Before forcing to fit, the maximum gap used is 1/2" (12.7 mm), while before welding, the gap for lap welds is considered to prevail.
11. The maximum misalignment normally allowed is t/4 for pleasing appearance and for strength and fatigue. In out-of-sight locations that are not strength critical, up to t/2 is allowed.
12. Weld reinforcement up to 1/16" (1.6mm) above flush is all that is normally considered necessary. Any more weld reinforcement is looked at as simply increasing the weld cost, and leading to problems when high fatigue strength is required, since the notch formed at the edge of a reinforcement bead is a surface stress concentrator.

Weld size used for nominal 1/4" or smaller welds is ± 0 , and for larger welds it is $\pm 1/16"$ (1.6mm).

Weld Undercut allowed in most United States shipyards is 1/32" (0.8mm) or less when stress is parallel to the weld, and more effort is made to eliminate it when stress is perpendicular to the weld. However, any undercut is considered to be cause for the welder to examine his equipment and technique.

13. Intercostal Misalignment at cruciform joints should be the subject of more testing. The presently attainable levels for misalignment appear to be:

- t for non-strength members
- t/2 for strength members in non-critical locations
- t/3 for strength members at top and bottom of hull girder in midship 1/2 length

14. The presently attainable limit for profile warp seems to be about $\pm 1/4''$ (6.4mm).
15. Stiffener Bend is similar to straightness of fabricated shapes.
16. Minimum Distances between Butt Welds and between Butt Weld and Fillet Weld need more research to determine the effects of Heat Affected Zone as well as shrinkage. Dependence on base material and on fixity of surrounding structure is important.
17. For cylinder diameter the limits normally used for subassembly and overall dimensions are applied unless special design requirements require better tolerances.
18. Curved Shell Accuracy directly influences unfairness of the finished plate panels. The most widely used limit, for most shell plating, is $\pm 1/4''$ (6.4mm).
19. Subassembly Accuracy of dimensions is maintained in most shipyards to a limit of $\pm 0.05\%$. Out-of-squareness is considered more tolerable than over or under size, and the widely used limit is 0.1%.
22. Unfairness of all hull plating need not be uniform for bottom, side, and deck because the need for fairness varies, e.g., bottom and lower side shell should be fair for hydrodynamic reasons, upper side shell should be fair for aesthetic reasons, and deck plate should be fair to prevent puddle formation and to prevent damage by large cargo items. Unfairness of plating, especially large spans of plate, may be a function of improperly cut or fitted support structure as well as a function of cooling after welding (hungry-horse effect). If the plate were forced to make up a gap between itself and frames, the result would be unfair shell and high residual stress in the plate and frames. The practice in the shipyards surveyed is generally to follow the unfairness limits given in reference (4).
23. Overall Dimensions of L, B, D, keel flatness, and deadrise are normally kept within 0.1% accuracy. Draft and Freeboard Marks are maintained within $1/8''$ (3.2mm).

The numerical values for those of the above structural deviations which appear to be the most widely found and which can therefore be considered to be the presently attainable levels in United States shipyards with modernized equipment and controls are listed in Table 7.1.

5.0

str
of
ass
dep

cre
mer
and
fec

5.1

up
gen
the
str
eng
tha
use
dic
mor
int
sea
abo
renc
gap
use
of
fact
form
tot
dic

the
quit
is s
deri
coul
and
comb
tech
obta
crit
high
asse

5.0 FOLLOW THROUGH OF A TYPICAL STRUCTURAL DEVIATION

Any individual structural imperfection, as categorized in the listing of structural deviations in Section 3 of this report, is the result of a multitude of factors and/or other structural imperfections existing in the material or the assembly. This is equivalent to saying that most structural deviations are interdependent on each other.

The objective of this section is to review all factors contributing to the creation of one typical structural deviation: misalignment of two opposing members attached to a through member. In doing this, all phases of ship design and construction are considered, the causes and effects of interdependent imperfections are investigated from a practical viewpoint.

5.1 FACTORS RELATED TO IDEAL DESIGN

The ideal structural design requirement for a ship is for it to stand up to the loads that internal weight distribution and external seaway excitation generate. Other loadings, such as machinery vibration, may serve to complicate the matter. Using modern techniques, engineers can produce accurate analyses of structural loadings and responses provided the input is accurate. In many engineering structures the majority of loads can be determined accurately, so that designs no more than adequate for the service intended can be produced and used safely. However, in ocean engineering structures the loads cannot be predicted accurately. Over a 20-year service life, a cargo ship may have one or more fundamental changes in type of cargo carried, with resultant changes in the internal weight distribution. More important, however, are the unknowns in the seaway environment. Changes in service route only make worse the uncertainties about such factors as maximum expectable wave height and the frequency of occurrence of various lesser wave heights. Safety factors are necessary to cover the gaps in knowledge that such changes and uncertainties produce. Some designers have used sophisticated ship motion studies to provide a more accurate determination of seaway excitation and ship response, hence to allow the use of reduced safety factors. The majority of naval architects still rely on the experience-derived formulae in the rules of the classification societies. This practice is not totally inaccurate because the experience of the past provides a reasonable prediction of the future as long as other factors remain relatively constant.

Granted that structural loadings on ships are known only approximately, the levels of arbitrariness and factors of safety in most design criteria are still quite high. This is because the execution of ideal designs in actual construction is subject to unknown deviations from the designers' plans. The experience-derived formulae try to account, implicitly, for all unknowns. If a designer could know that joints would line up to a certain degree and that the material and welds would have a certain level of conformity with specifications, he could combine ship motion analysis with sophisticated strength and fatigue analysis techniques to determine the scantlings and arrangements. Most designers cannot obtain the requisite information, so they must fall back on the experience-derived criteria in the rules. In a few cases, notably the LNG ships, the stakes are so high and the experience is so scant that an extensive effort has been made to assess and control the effects of deviations from nominally ideal design details.

Even here the process has not been direct. The designers applied arbitrary material and weld safety factors and then used tests and mathematical analyses to determine the tolerance levels that would be required to keep stresses within "safe" levels. Instead, the process of achieving accuracy in the shipyards could have been assessed, and the designs made with safety factors appropriate to the ascertained accuracy level.

5.1.1 Deviations Originating from the Base Materials

The deviations from idealized design begin with the condition of the material, which is a function of mill practice and inspection procedures at the mill and the shipyard. Not all shipyards bother with receipt inspection. Indeed, some depend on the classification society and mill inspections to ensure delivery of acceptable material. The ABS (and presumably other classification societies) perform surface inspections only when specially requested to do so. The societies do ensure that the basic chemistry and material properties are correct, and this of course is fundamental to having the actual structure conform to the design. But surface-detectable flaws are important as well.

The most obvious material flaws are pits and corrosion, both of which have been related to undercuts in welds. Corrosion products generate additional slag during welding. Most welders know enough to remove oxide films from the weld area before welding, so that the problem is somewhat reduced. Pits, however, cannot be removed by wire brushing. A welder making an in-tolerance weld might cause short duration or large, harmful undercuts if he were not careful to notice that pits start undercuts that require special attention to stop. It is shown in Section 5.2 that undercuts can be harmful or inconsequential depending on their location, but they are generally undesirable. Hence, anything that adds to a welder's problems in avoiding undercuts is undesirable. Those shipyards that do perform receipt inspection reported pit tolerances ranging from 1/64" to 1/8", while their undercut tolerances ranged from 1/32" to 1/16".

A less easily detected flaw is lamination. As pointed out in Sections 3 and 5.2, laminations, in special cases, cause serious problems in welds. Small laminations often grow when heated by welding. A lengthwise stressed member would not suffer from this. But a thickness stressed member would suffer a significant loss of effectiveness. For example, at a perfectly aligned cruciform joint where the non-continuous members were lengthwise stressed, varying tensile loads eventually would open up the outer layers of a laminated continuous member. Since a laminated plate acts as a layered set of thin plates, with reduced resistance to shear between layers, the plate would bend more easily. The problems of fatigue at cruciform joints that Reference 21 discusses have been examined by some U.S. shipowners using finite element methods; it has been found that fatigue propagation would be accelerated by the laminated condition of the plate.

Fortunately, most laminations occur at or near the edges of rolled plates, so they are visually detectable. Ascertaining the extent of lamination requires sophisticated techniques, of which ultrasonic inspection probably is best. Some shipyards already use UTS to check for laminations in receipt inspection. All material need not be examined, only that for those areas that will be subject to thickness direction loading.

pr
ir
to
ir

of
cu
he
to
er
we
by
nor
spe
tha

ing
the
ing
it
has
sho
to
imm
sli
the
eas
acc
ber
frou
and

inac
siti
joir

memt
tole

5.1.2 Deviations Originating from Processing in Shipyards

After material has been received in the yard, and perhaps blasted and primed to reduce wastage during storage, the deviations due to processing inaccuracies commence. The various manufacturing processes, ranging from lofting to erection and fairing of prefabricated subassemblies, are subject to inherent inaccuracies.

Two British Ship Research Association reports (24,25) show the results of investigations on the accuracy of using 1/10 scale drawings to guide flame-cutters. The initial full-size error imparted to the path of a flame-cutting head was shown to lie in the range $\pm 0.18''$. U.S. shipyards have reported tolerances on accuracy of cutting line in the range of 1/16'' to 1/4''. This error is important because if two plates, intended to butt together on the ship, were cut by the same cutter, the gap before welding could be increased or reduced by a maximum of 1/2''. Alternatively, if the gap before welding were kept at the nominal value, the dimension of a subassembly could be changed. One shipyard specifically pointed out that plates are measured as they come from cutting and that if one comes out undersize, the next is deliberately cut oversize.

Accuracy of cutting line is important because it influences the fitting together of components, hence directly affects the effort necessary to make the fits correct as well as the cost of other than nominal welding. Upon examining the graph "General Relationship of Cost to Dimensional Accuracy," Fig. 5.1, it is easy to agree that, after a relatively low level of dimensional accuracy has been achieved, the fabrication shop costs will rise. Because a fabrication shop deals with individual subassemblies, a certain level of accuracy is necessary to put them together. But beyond that, more accuracy may be superfluous to the immediate task. The behavior of the berth cost versus dimensional accuracy is slightly more complicated. Again, a certain level of accuracy is necessary for the assembly, or in this case, the erection and joining of subassemblies. But ease of erection is dependent on the accuracy of work produced at earlier optimal accuracy level; the berth workers may have to rework the subassemblies. Hence, berth work requires that a higher level of dimensional accuracy be maintained from the beginning so that the workers can use their time for primary production and not for correction of faults in the elements produced at previous stages.

After cutting and shaping, the fabrication process encounters the inaccuracies inherent in fit-up operations. These cover a wide spectrum of situations, and only the selected typical deviation of constructing cruciform joints will be considered here.

Misalignment of intercostals where they are welded to the through member, forming a cruciform joint, often is cited as the classic structural tolerance problem. The misalignment would seem to be the direct result of

inaccuracies in fit-up, or the consequence of the difficulty in checking alignment when the through member is a deep transverse or a bulkhead. The cure for inaccuracies obviously is better workmanship, including careful measurement, precise positioning, and adequate clamping or tacking. The cure for the second cause could be to drill holes to make accurate measurements on both sides of the through member, or to use a non-destructive device such as an ultrasonic "Locatron" for determining the exact positions of opposite members.

If the intercostals were individually installed, aligned, tack welded, and finish welded, alignment would be an independent matter at each cruciform joint. However, in many modern shipyards the problem is not as simple as the preceding discussion suggests. Today, prefabrication of panels and even 200 ton subassemblies is common, and other sources of alignment problems have arisen. For example, one shipyard reported that structural shapes as received from the steel mills are not suitable for shipyard work. If some angle beams received from the mill or fabricated in the yard were bent in the plane of flange, then even careful measurement and workmanship in constructing egg crate assemblies might not prevent misalignment of intercostals where the subassemblies join together.

The reported tolerance for straightness in flange plane ranged over $1/8''$ in $10'$, $1/4''$ in $10'$, and $3/8''$ in $3'$. The first two tolerances should not cause much problem in joining subassemblies. But the third could well lead to substantial misalignment if the beam protruded from Subassembly 1 into Subassembly 2, as shown in Figure 5.2. The beam could be aligned perfectly at Transverse A and at the edge of Subassembly 1, but at Transverse B it could be off by $3/8''$ for every $3'$ from the subassembly edge to Transverse B. Additionally, the beam might be misaligned at A and at the edge. The best case would be for these two errors to combine with the beam curvature to result in zero error at B. The worst case, assuming an alignment tolerance of $t/2$, would be an error of $3t/2$ at B, added to the error caused by beam curvature. These of course are pre-welding errors, but unless they were detected, they would become welded-in misalignments. And if they were detected, the correction procedure of force-fit would generate large locked-in stresses.

The locally generated problems with cruciform joints are augmented by more global problems such as alignment of subassemblies relative to each other. Erection and fairing of subassemblies to form a ship on the building ways is complicated by several factors. First, it is difficult to position the units exactly because the reference lines and methods of location have inherent inaccuracy. As one shipyard noted, they have no problem with shifting building ways, but constructional inaccuracies in the ways themselves still disrupt the accuracy of the reference grid they use. This is aggravated by the inaccuracies of the tools used to locate the units relative to the reference lines. The tapes stretch, and plumb lines deflect in any breeze. This inaccuracy is being reduced by use of surveyors' transits and, more modern yet, laser beam devices, but such exotic devices are not commonly used. Second, the dimensional accuracy of each subassembly unit is not well known. Distortion due to temperature effects and lifting forces confuses the situation. Third, the accuracy of the part of the ship already erected is affected by welding

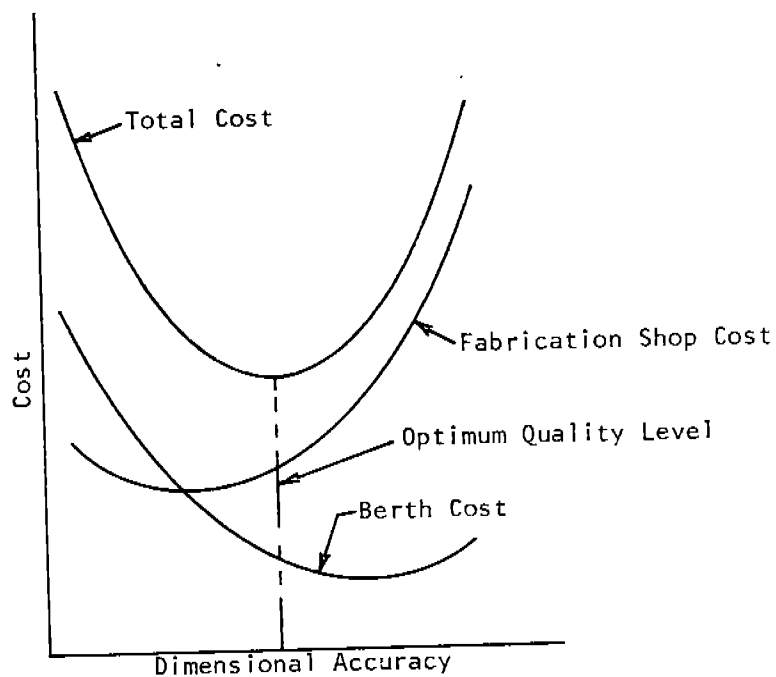

Fig. 5.1: General Relationship of Cost to Dimensional Accuracy
(Reproduced from Reference 25)

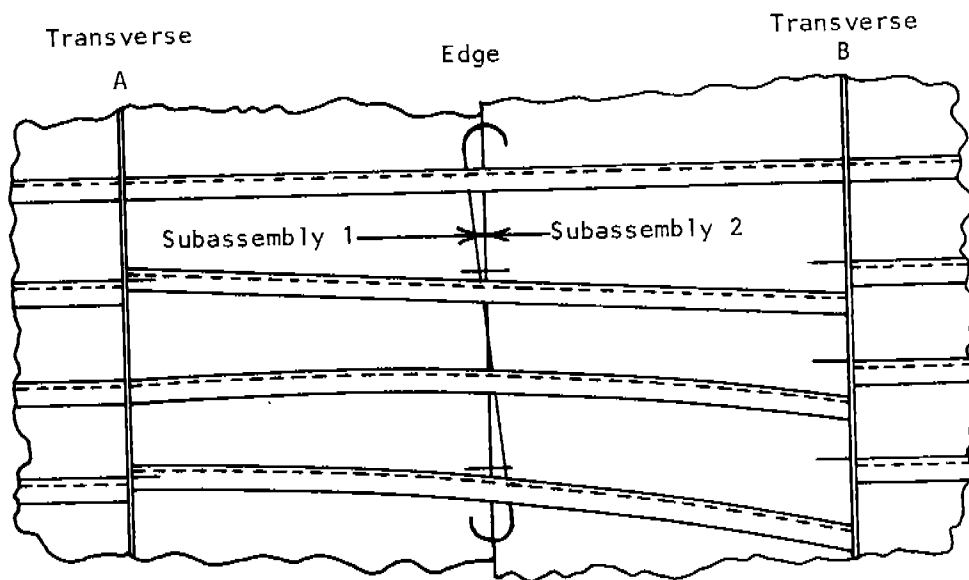

Fig. 5.2: Alignment of Subassemblies

and by settling of keel blocks and the berth itself, all tending to inhibit precise knowledge of the relationship between the designed and actual situation of the ship during construction. As evidence, most shipyards have reported that ships grow by a maximum of 1" per 100' in length, and that bows cock-up by 1/4" to 1/2" per 25'.

Another misalignment problem, that apparently few shipyards maintain any control over, involves the angle between the flanges and webs of intercostal beams. If, at a cruciform joint, one beam had an up-tilted flange and the other had a down-tilted flange, the shipyard tolerance of 1/4" to 1/2" tilt could lead to 1/2" to 1" misalignment of the outboard end flange fibers. Fortunately, this misalignment decreases with proximity to the beam web, so only bending loads in the flange plane cause appreciable twisting stresses due to the misalignment. Since most loads on intercostals are lengthwise, this misalignment problem probably is of little importance.

Also to be considered at cruciform joints are all the weld-quality related tolerance problems such as slag inclusions, porosity, gap before welding, and heat distortion. Some shipyards have complete specifications on allowable weld defects, while others leave the matter entirely to "good workmanship". The classification societies have their own inspection tolerances, e.g. ABS has a publication, "Non-destructive Inspection of Hull Welds" (9). There are two important aspects of all these specifications: NDT is, as discussed in Section 4.6 of this report, a process control mechanism to ensure that good workmanship is practiced. Second, combinations of problems must be considered. A misalignment of t/1 combined with perfect welding could produce a better cruciform joint than a combination of t/2 misalignment, 1/16" undercut, slag inclusions and porosity up to the ABS limit, and large residual stresses. This illustrates that complete tolerance specifications still need to be tempered with fabricators' and inspectors' judgement.

A Bath Iron Works study (18) and a Royal Institution of Naval Architects paper (19) have shown that, regarding gap before welding for fillet welds, shipyards would do well on cost basis alone to regulate their processes to produce accurate gaps. "If the fitting is poor, the cost of fillet welding will mount rapidly." In Ref. 18, it can be seen that cost increases with oversize gap.

5.1.3 Precautions to Reduce Deviations at Source

The question naturally arises of what to do to reduce the problem at cruciform joints and to reduce other tolerance related problems.

Receipt inspection can reduce wasted effort at later stages by rejecting or sending for repair those incoming materials that are unsuitable. Immediately following inspection, blasting and priming can prevent suitable material from becoming unsuitable, especially regarding welding, during storage and exposure in unprotected subassembly stages.

Following receipt inspection and processing, the control of fabrication processes becomes paramount in making the actual product conform to the design. Cutting line accuracy has been shown to be only fair when 1/10 scale drawings are used as guides for flame cutter head. One of the B.S.R.A. reports (25) favored, in 1968, the replacement of manual lofting techniques by computer-aided design systems from which could be derived control tapes for numerically controlled flame cutters, frame benders, etc. Numerous shipyards are presently using such systems. However, shipyards not equipped with N/C equipment can still improve cutting and forming quality by rigorous monitoring and correcting, and even compensating for deviations.

The construction of subassembly units should be seen as a middle step in the construction process rather than as a step to be optimized for the immediate problem (sub-optimized). Referring again to Fig. 5.1, it is important that the subassemblies be constructed with what appears to be too much accuracy, to save re-work later.

The problems with prefabricated subassemblies can be reduced by making adequate allowances for adjustment of the inevitable imperfections in material and workmanship. One shipyard learned the hard way that completed subassemblies are very difficult to mate together exactly, even when extreme care is exercised. In the example in Figure 5.2, the intercostals should not be welded at or near the edge, so that adjustment at C would be relatively easy. As long as the beams are within straightness tolerance, it makes no difference in structural strength if the beams are not on the mark at the edges after joining of the subassemblies.

Ref. 23 advocates the use of a grid system so that erection and joining of subassemblies can be done relative to the grid rather than relative to the subassemblies already in place. At least one of the shipyards surveyed in this project uses a similar system. The virtue of such a system is that it prevents an error in one subassembly from cascading through subsequent work. It also helps to isolate and expose deviations before they become firmly built in. The grid system of course must be very accurate and must be readily accessible for reference measurements. The problem with such a system is that it might unduly restrict the whole process of erecting and joining completed subassemblies. As indicated in Section 5.1.2, most shipyards have found that their finished product is longer than its nominal length by as much as 1 inch per 100 feet. This has been accepted as part of the price for the virtues of subassembly methods. A pre-established grid system would not allow such a cascading deviation, but would require greatly improved subassembly construction and joining methods, and hence might become an impediment to overall production rate.

5.2 INFLUENCE OF STRUCTURAL DEVIATIONS ON STRENGTH

Very few ships that were reportedly inspected in accordance with previous or current structural and weld tolerance standards have failed in service. It has been difficult to establish that the ships that have experienced failures did so because of structural deviations, or that ships that were known to have substantial misalignments, etc., were failure prone. Only four substantive examples were obtained:

1. One shipowner/operator reported that misalignment of intercostal longitudinal bulkheads on passenger ships caused fatigue cracking. Misalignments of up to 1" had to be corrected by breaking out and rewelding the bulkheads or by attaching brackets to provide continuity.

2. In some cargo ships converted to container ships, hair-line cracks developed at the butts in the longitudinals of the box girders. A finite element analysis showed that many discontinuities that ordinarily would not bother an inspector were the cause of the cracks. Both poor design details and slag inclusions in manual welds were found to be the problem sources. This example illustrates a situation where stresses were high, hence tolerances (or perfection) were critical. However, it also may illustrate a case where the design was not adequate for unexpectedly high stresses.

3. Designers and builders of LNG ships used finite element analyses to investigate the tolerance allowed for alignment of butt and cruciform joints. They found, as did the researchers for the JSQS, that "critical" joints required a limit of $t/3$ rather than $t/2$ to ensure that stress levels would not be exceeded and fatigue problems would not be encountered.

4. A vessel constructed in one shipyard developed serious structural deficiencies shortly after it entered service. The yard was called in and an extensive alignment survey was conducted which revealed many sources of failure due to misalignments of various types. All deficiencies were corrected by the shipyard, at considerable cost, and this incident was sufficient reason for the yard to incorporate into the yard organization a comprehensive quality assurance department.

Reference (20) contains the detail shown in Figure 5.3 as a detail design problem (poor detailing of design). However, it is also a structural tolerance or deviation problem, since the design in A arose because B was difficult to achieve during construction. If close tolerances were followed, the design in B would be achievable. It should be noted that two detail problems are involved here:

- (1) The bracket in A must transfer deck load from beam to frame, while the bracket in B has less load on it,
- (2) The scallops in A are sharp-cornered stress concentrators, while B has no scallops at all.

A
of devic

1.
the str
bending
so that
perpend

2.
occurs c
of weld
occurrer
present
these ir

3.
by destr
the U.S.
but not
member.
the effe

4.
paper (

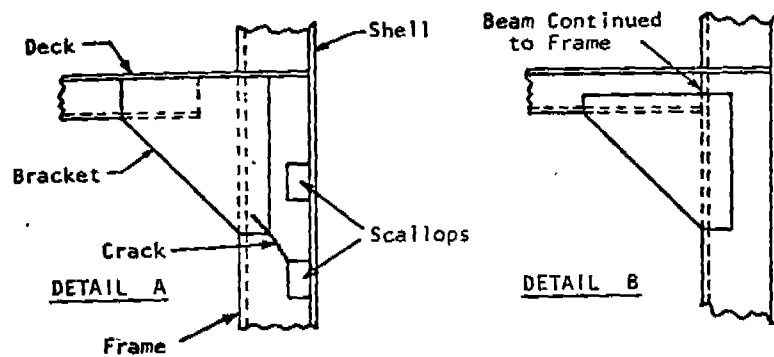

Fig. 5.3: Detail Design of a Beam Bracket
(Source: Reference 20)

A wealth of information exists in published literature regarding influence of deviations on the strength of general engineering as well as ships' structures:

1. Laminations in plates, produced by sulphide or oxide inclusions, reduce the strength in tension in the thickness direction and reduce the strength in bending, as discussed in Sections 3 and 5.0. While steel usually is fabricated so that major design stresses are parallel to the lamination fibers, stress perpendicular to the fibers cannot be avoided entirely.

2. A very closely related phenomenon is lamellar tearing, which sometimes occurs during construction at major structural intersections due to the complexity of weld connections which results in high through-thickness stresses. Its occurrence has been related to the presence of non-metallic inclusions normally present in structural steel. The cures for lamellar tearing range from reducing these inclusions to redesigning the weld connections.

3. Misalignment of intercostals at cruciform joints has been investigated by destructive testing in Japan and the USSR, and by finite element analysis in the U.S. The decrease in joint strength caused by misalignment is significant, but not as much as the fatigue problems that arise due to bending of the through member. Reference 1 presents a summary of worldwide efforts to investigate the effects of misalignment in cruciform and other type joints.

4. Regarding the misalignment of cruciform joints, the authors of a Soviet paper (21) reach the following conclusions:

- a. Displacement and non-straightness, occurring during assembly of joints, considerably increase the number of fit-up jobs. The number of fit-up jobs can be reduced with the aid of technological and administrative measures to increase the accuracy of section construction and mounting on the ship, and to increase tolerances for the displacement in cruciform joints and for non-straightness.
- b. The study of the influence of shape errors on the stressed condition and on the welded joint strength allowed a recommendation for widening the tolerances for joint planes displacement to the range of $0.5t$ to $1.0t$ and for non-straightness to $1.0t$.

c. It is also to be noted however that:

- i. The calculations show that under loadings in the plane of the plates and ranging from 45% to 50% of yield stress, the sum of bending stress and loading in butt joints "does not exceed" the yield stress in the presence of 0.5t displacement and 1.0t non-straightness.
- ii. In cruciform joints the same stresses develop if displacement or non-straightness values do not exceed 1.0t.
- iii. This is another way of stating that such deviations from ideal design may lead to a doubling of stresses at certain spots in the joints.
- iv. Additional local stresses on the surfaces of the plates were not included in the sums of stresses above.
- v. Fatigue tests of specimens showed that welded joint fatigue strength is decreased especially when butt joint misalignment is 0.5t or more, when cruciform joint misalignment is 1.5t or more, and when non-straightness is 1.25t or more.

Few classification societies have their own well defined structural tolerance standards; therefore it is difficult to assess their safety factors as to the allowances for structures that deviate from the designs. By documenting the typical tolerances and accomplished results in a number of U.S. shipyards, a rough idea can be obtained as to the tolerances that may prove at least adequately safe when current design criteria are applied. Some maximum tolerances should be rigidly defined because in the context of present design criteria and inspection techniques, they have been found to provide adequate safety, are easy to check, and are generally accepted. For instance, $t/2$ misalignment at cruciform joints has been listed by most shipyards. Ref.21 proposes $t/1$ misalignment as acceptable, but the fatigue characteristics of such a joint are questionable. Also, this figure was developed for otherwise perfect joints, free from weld defects and material flaws.

5. Weld defects are the subject of most NDT, hence it is plain that they are considered as major degradations to the ideal, "as-designed" joint. Visual inspection can be used to find undercuts. As seen in section 3, undercut is mostly a function of proper arc and welder skill, although pits can aggravate the situation. Undercuts can be harmful in two ways: if a double undercut occurs in a plate girder web, an appreciable loss in plate thickness results. Second, if a force must be transferred transversely to an undercut, the undercut may act as a stress raiser. This second effect is more critical. If a girder web has a local thickness reduction, plastic strain may result but this probably will not lead to failure. However, a stress raiser has high probability of leading to cracking.

Do
pl
wc
ap
ir
ef

the c
facto
(22)
reduc
1967,
for w
tecti-
to es
vario
These
Ref.2
and b
good
long

f the
sum of
ed"
d 1.0t

ement

ideal
ts in

were

gue
nment
t or

y
rs as
ting
ds,

erances
and
easy
uciform
t as
e.
d

hey
al
s
te

s.
ercut
der
bably
lead-

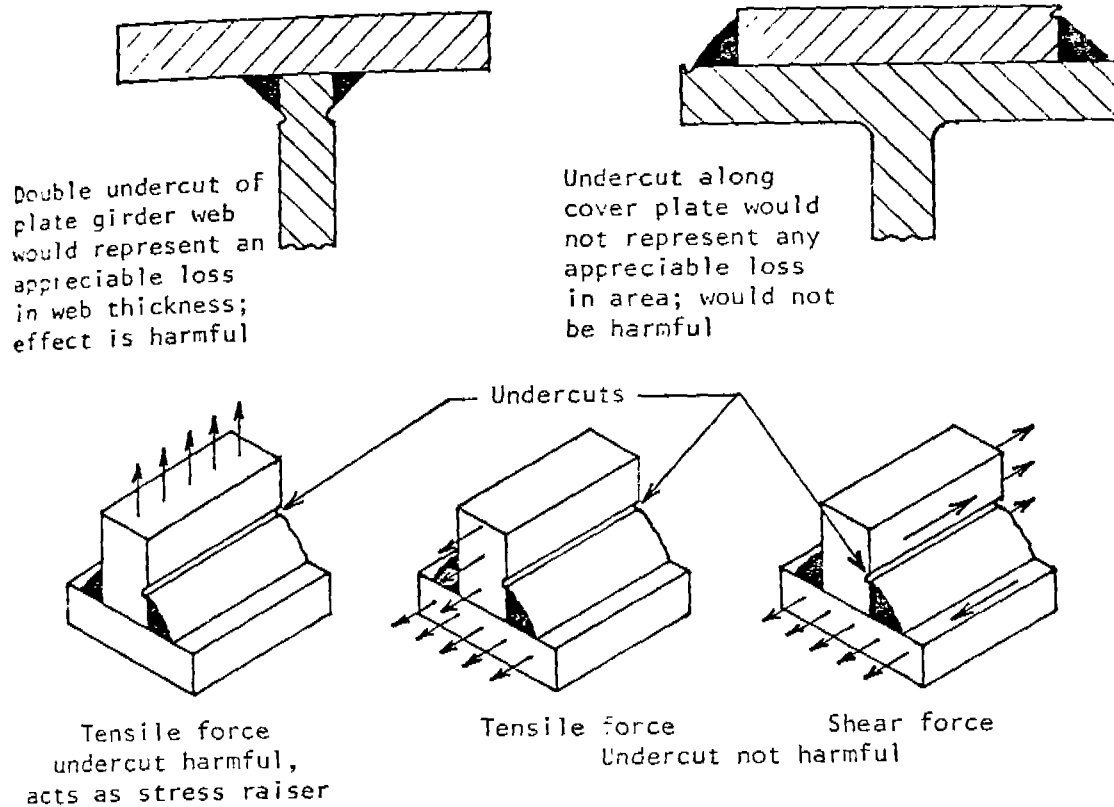

Fig. 5.4: Effects of Weld Undercut (Source: Reference 28)

6. In establishing many other tolerances, trade-offs are needed between the costs of careful workmanship versus the costs involved with increased safety factors to accommodate less than perfect fits. In 1965, Shimizu and Sugisaki (22) reported that, "Norwegian classification societies are now ready to approve reduction of weight through raising grade of workmanship in the yard...". The 1967, 1969 and 1975 issues of Det norske Veritas rules, however, made no allowance for weight reductions due to raised grade of workmanship. Only corrosion protection was used as a criterion for reduced scantlings. There is also a need to establish the relationships between working accuracy and cost of fit up at various levels of assembly, so that overall costs versus accuracy can be evaluated. These trade-offs and relationships are matters for each shipyard to determine. Ref.21 showed one opinion of how to establish tolerances for cruciform and butt joints. The obvious motivating factor was ease of construction, via good accuracy of parts and liberal allowances on the definition of good fit, as long as it was adequate to satisfy strength requirements.

6.0 CONCLUSIONS

It is believed that the surveys and interviews conducted with nineteen commercial shipyards, eighteen shipowner/operators, four classification societies, and two steel mills have provided sufficient data to assess the state-of-the-art of the U. S. shipbuilding industry's attitude toward, and performance regarding, structural tolerances.

It is further believed that the present-day status in most major U.S. commercial shipyards of providing "good shipbuilding practice" in their constructions has been studied and documented. This is true despite the fact that the amount of data collected for formal shipyard structural tolerances is small and that the amount for actual structural deviations from the "ideal design" is even smaller.

There appear to be two dominant reasons for this shortage of factual data.

- a) The majority of shipyards have no formal approach to regulating structural tolerances; they also lack a consistent data gathering system for recording actual deviations.
- b) The determination of a sufficient quantity of actual structural deviations would have required an extensive program of measurements and non-destructive testing at each shipyard during the course of the present survey project. This would have required much longer survey periods to be reserved for each yard and would also have required an extensive input of time and manpower by the yards.

This short study has nevertheless shown that there is a wide spread in the structural deviation values as reported by different shipyards, and even within individual yards.

Even though a small quantity of structural deviation data was collected based on consistent records, it was still possible to obtain some indication as to the maximum and minimum values experienced in most shipyards.

The collected data is reported in Section 4, Table 4.2, and represents the structural deviations normally experienced in shipyards during ship building and repair activities, along with the allowable tolerances being used.

The deviation and tolerance levels reported in the survey have been subjected to an averaging process, with the purpose of obtaining a compilation which can be considered to represent a cross-section of the U. S. shipbuilding yards. The resultant tolerances are listed in Table 6-1, and labelled "USA Practice", as was done in Reference (1) based on what information was then available. Comparison of these tolerances with the published international standards reveals that there are no great overall differences. However, the U. S. practice appears to be generally more liberal than other standards. It must be noted that the values reported here represent only a subjective averaging of values obtained in various shipyards and that as such, they do not represent the actual workmanship of any one shipyard.

As far as "in-service" deviations reported by shipowners are concerned, the data collection is very limited. This is mostly due to the fact that no records exist of structural deviations developing after a vessel enters service. Based on their recollections, however, some shipowner/operators did report a few cases of such deviations. It appeared that in a number of vessels structural deficiencies have developed in service which could be traced back to initial structural deviations. These are discussed in Section 4.1.

The existence or the lack of built-in initial structural deviations on completed vessels will depend, primarily, on the quality of workmanship provided by the shipyard. Secondly, it will depend on the structural inspection and quality assurance procedures in the yard because these will help discover and eliminate deviations.

Most U.S. commercial shipyards do not enforce written structural tolerances. As stated in Section 4.2, most yards rely upon the experience and know-how of their own production supervisors as well as that of regulatory body inspectors and owner's representatives. The dominant factors in assessing most structural deviations appear to be such abstract opinions as "good marine procedure", or "pleasing to the eye". However, as pointed out earlier, a few shipyards do maintain written tolerances. A compilation of such tolerance standards is included in Appendix 9.2.

	11
	2
	3
	4
	5
	6
	7
	8
	9
	10
	11
	12
	c
	E
	c
	di
	of
	re
	to

ITEM	Japanese Standard Tolerance Range				German Standards		Swedish Standards		U.S.A Practice	
	inch	mm	inch	mm	inch	mm	inch	mm	inch	mm
1b - Pits			1/8	< 3	1/8	< 3	1/8	< 3	< 1/8	3.2
2 - Cutting Line Accuracy	3/32	± 2	1/8	± 3					± 3/16	4.8
3 - Edge Roughness (Weld Groove)			1/8	< 3					< 1/16 shop < 1/8 field	1.6 3.2
4 - Edge Straightness										
a Automatic	1/64	± .4	1/64	± .5					± 1/8	3.2
b Semi-automatic	1/32	± 1.0	3/32	± 2.5					± 1/8	3.2
c Manual									± 3/16	4.8
5 - Groove Depth	1/16	± 1.5	3/32	± 2.0					± 1/8	3.2
6 - Taper Angle		± .5d		± 1.0d					± 5%	
7 - Fabricated Shapes										
a Flange Breadth	1/8	± 3	3/16	± 5	-5%, + no limit				± 1/4	6.4
b Flange Angle		2.5%		4.5%	± 5%				5%	
c Straightness		0.1%		0.25%					.25%	
8 - Rolled Shape Flange Angle	1/8	± 3	3/16	± 5					± 1/4	6.4
9 - Welding Gap										
a Fillet	3/32	< 2	1/8	< 3	3 < a < 5	3/16	< 5	< 3/16	4.8	
b Butt		2 < a < 3.5	3/16	< 5		5/32	< 4	3/16	4.8	
c Lap	3/32	< 2	1/8	< 3		1/8	< 3	< 1/8	3.2	
10 - Beam & Frame Gap	1/8	< 3	3/16	< 5	3/16	< 5		< 3/16	4.8	
11 - Butt Joint Misalignment		Strength Members	1/8	< .15t < 3	3/32	< 2		< .15t	< 1/8	3.2
		Others	1/8	< .2t < 3			5/32	4 max		
12 - Weld										
a Reinforcement									< 1/8	3.2
b Dimension				-0.1a		-(.3+.05a)			-1/16	-1.6
c Undercut direction of load relative to weld	//		1/32	< .8	1/16	0.1a < 1.5			< 1/32	0.8
	⊥				1/32	0.05a < 1.				

Table 6.1 Comparison of U.S.A. Practice on Structural Tolerances with Published International Standards

ITEM	Japanese				German		Swedish		U.S.A		
	Standard Range		Tolerance Limits		Standards		Standards		Practice		
	inch	mm	inch	mm	inch	mm	inch	mm	inch	mm	
13 - Intercostal Misalignment	Strength Members		< t/3		< t/4 +3		< t/2		< t/2		
	Others < t/3		< t/2				< t/4 +3				
14 - Profile Warp	200 mm				3/8	< 10			< 1/4	6.4	
	500 mm				11/16	< 18					
	1000 mm				1.	< 25					
15 - Stiffener Bend	$l < 1000$ mm		3/16	< 5	5/16	< 8	5/16	< 8	5/16	8.0	
	$l > 3500$ mm		3/8	< 10	1/2	< 13	1/2	< 13			
	$1000 < l < 3500$		interpolate								
16 - Weld Spacing	a Butt - Butt		1-1/4	> 30	2	> 50 + 4t			> 3	76	
	b Butt - Fillet		3/8	> 10	1-1/4	> 30 + 2t			> 3	76	
17 - Cylinder Diameter	3/16	±5	5/16	±7.5	for $D \geq 1000$ mm $\pm (.005 D + 1)$				±1/8	3.2	
					1/4	±6					
18 - Curved Shell Accuracy	3/32	±2.5	3/16	±5					± 1/4	6.4	
19 - Subassembly	a Dimensions		5/32	±4	1/4	±6			± 1/4	6.4	
	b Squareness		5/32	4	5/16	8			3/8	9.5	
20 - Hatch Coaming Dimensions	3/16	±5	3/8	±10					± 3/8	9.5	
21 - Access Openings	a Dimensions		5/32	±4	9/32	±7			± 1/4	6.4	
	b Deformation		.2%		.3%				1/8	3.2	
22 - Unfairness	a Bottom		5/32	4	1/4	6	7/16	11	1/2 12.7		
	b Side		3/16	5	9/32	7	3/8	9	1/4	6	3/3 9.5
	c Deck		1/4	6	3/8	9	3/8	10	1/4	6	1/2 12.7
	d Superstructure		5/32	4	1/4	6	1/4	6	1/4	6	1/2 12.7

Table 6.1 continued

ITEM	Japanese				German		Swedish		U.S.A	
	Standard Range		Tolerance Limits		Standards		Standards		Practice	
	inch	mm	inch	mm	inch	mm	inch	mm	inch	mm
23 - Overall Dimensions										
a Length	0.05%		4	100	0.1%				0.1%	
b Beam	9/16	±15			0.1%				0.1%	
c Depth	3/8	±10	3/8	10 max	-1.%				0.1%	
d Keel Flatness	9/16	±15			1	+25mm/ 100m			1	25.4
e Forebody Rise	1 1/4	±30			+2	+50			5/8	15.9
f Afterbody Rise	3/4	±20			+2	+50			1	25.4
					-1	-25				
g Deadrise	9/16	±15			+1	±25			1/2	12.7
h Draft Marks	1/32	±1	1/16	±2	1/16	±2			1/4	6.4
i Freeboard Marks	1/64	±0.5	1/64	±0.5					1/8	3.2

Table 6.1 continued

7.0 RECOMMENDATIONS

7.1 Recommended Guide to United States Shipyard Practice in Structural Tolerances

Table 7.1 is a compilation of what appears to be the United States practice in structural tolerances, based on inputs from all institutions surveyed. The tolerance values shown reflect the capabilities of large, well equipped, and relatively modern shipyards in the United States. It will be seen in Table 7.1 that the following basic tolerances are covered:

- Cutting Line Accuracy
- Dimensions of Fabricated Shapes
- Misalignment
- Weld Geometry
- Accuracy of Curved Shell
- Accuracy of Subassemblies
- Unfairness of Plating
- Accuracy of Hull Form

Additional descriptive information on these and a few other candidate structural tolerances can be found in Section 4.6.

It was not the intention of this project to produce any results other than a statistical representation of the current United States shipyard tolerance practices. The tabulation offered in Table 7.1 as the American shipyards' practices is included in this report as the investigator's opinion.

7.2 Relation of Structural Tolerances to Rational Design

The present day structural tolerances reflect an assessment of shipyard capabilities within a reasonable cost framework, the yard's past experience, and the results of some basic research into material and welding properties.

It is felt that more research work is needed to develop bases for determining tolerances. Finite element analyses of small assemblies and intersections, along with some destructive testing, have already been used to show the strength and fatigue characteristics of cruciform and butt type joints (17,21). More research work of this type will no doubt help increase the understanding of the stress phenomena in critical joints and will therefore shed light on the establishment of relevant and attainable tolerances and ways of considering these tolerances in the rational design efforts.

The advantage of a rational design accounting for imperfections which are known to be occurring on the final product is that the semi-empirical formulae of the classification society rules will not have to be followed. The rational design may be based on investigative methods such as the finite element analysis technique, and may study the structural model of the complete vessel, especially in the strength-critical areas, from the viewpoint of structural imperfections.

Cutting Line Accuracy	$\pm 1/16''$	$\pm 1.6 \text{ mm}$
Fabricated Shapes Dimensions (Note 1)	$\pm 1/4''$	$\pm 6.4 \text{ mm}$
Misalignment		
Butt Joints	t/4 for strength and/or appearance t/2 where neither is required	
Cruciform Joints	t/3 for critical strength members t/2 for less critical strength members t for non-strength members	
Welds		
Reinforcement Undercut	$< 1/16''$	$< 1.6 \text{ mm}$
Size (nominally $\leq 1/4''$)	$< 1/32''$	$< 0.8 \text{ mm}$
Size (nominally $> 1/4''$)	± 0	$\pm 1.6 \text{ mm}$
Curved Shell Accuracy (Note 2)	$\pm 1/4''$	$\pm 6.4 \text{ mm}$
Subassembly Dimensions	$\pm 0.05\%$	
Squareness (Note 3)	$\pm 0.1\%$	
Plating unfairness (Note 4)	$\pm 3/8''$	$\pm 9.5 \text{ mm}$
Overall Dimensions, including L, B, D, keel flatness, and deadrise	$\pm 0.1\%$	
Hull Markings (draft, freebd.) (Note 5)	$\pm 1/8''$	$\pm 3.2 \text{ mm}$

Table 7.1: Structural Tolerances in United States Shipyards

NOTES:

1. Tolerances given are for all sizes of fabricated structural shapes normally used in ship construction (see page 40, Item #7).
2. Tolerance for "Curved Shell Accuracy" is for deviation of actual line of shell from the design molded line.
3. Subassembly tolerances may be established as follows:

- a) Dimensional Accuracy
 % Deviation from design
 dimension

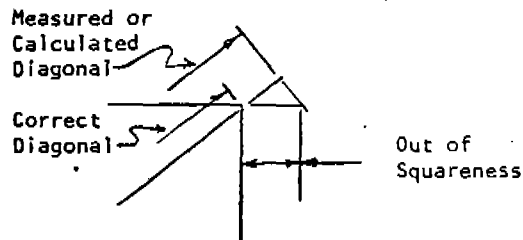
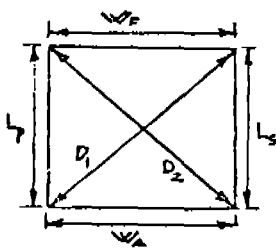

b) Out of Squareness

4. Tolerance values given are maximum for normally used thickness of shell, deck, and other strength structure plating. For larger thickness, unfairness, curves are used as reference basis.
5. Draft and freeboard tolerances are maximum allowable deviations of markings from design or assigned values.
6. In general, all of the tolerances shown in this table represent the levels of imperfection that are attainable with modernized equipment and controls.

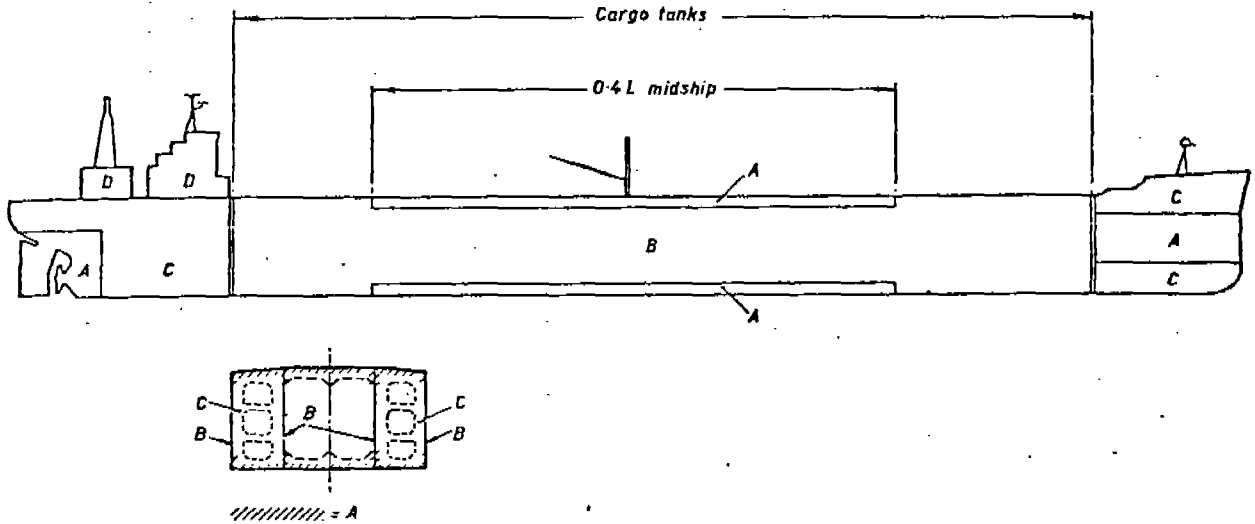

Fig: 7.1: A 210,000 DWT tanker divided into different critical quality areas.

(Source: Reference 6)

Some differentiation on the basis of location, allowable stresses, materials, and types of production equipment must therefore be made in establishing achievable structural tolerances. The approach in Fig. 7.1 covers the differentiation with regard to location and allowable stresses. Further work is required to take into consideration the effects of materials and production equipment.

After all factors have been considered, and practically attainable levels have been established for different strength critical areas of the vessel's structure, the problem would be reduced to one of introducing these established tolerances into the detailed engineering analysis of the structure.

7.3 Quality Assurance and Inspection Requirements in Shipyards

In order to ensure that allowable tolerances are not exceeded on the finished product and that no unacceptable or unaccounted for initial structural deviations are permitted, consistent inspection and quality assurance procedures are necessary.

For verification of adherence to allowable structural tolerances, the combined efforts of the structural inspection and quality assurance group must cover the following general areas:

Receipt Inspection of Incoming Material

Non-destructive testing

Visual structural inspections

Inspection and Measurements for:

- Misalignments
- Deflections
- Distortions
- Gaps before welding
- Out-of-Squareness
- Curvature

Dimensional accuracy checks for:

- Deformations of hull form
- Over-all dimensions
- Draft and Freeboard marks

Final Finishing Practices

Tightness Tests

8.0 REFERENCES

1. "Fabrication Factors Affecting Structural Capability of Ships and Other Marine Structures" Report of Committee III. 3, 6th International Ship Structures Congress, Boston, 1976.
2. "Japanese Shipbuilding Quality Standard (J.S.Q.S.) (Hull Part)," SNAJ Publication No. 8-2, Tokyo, 1975.
3. "Japanese Shipbuilding Quality Standards - Background Document." SNAJ Publication No. 8-3, Tokyo, July 1976.
4. "Fabrication, Welding and Inspection of Ship Hulls, "NAVSHIP 0900-000-1000. Naval Ship Systems Command, Washington, D.C., Oct. 1968.
5. "Alternative Methods of Non-Destructive Testing" Research Report by Lockheed Shipbuilding Corp., SNAME.
6. "The Acceptability of Weld Defects", Harrison and Young, The Naval Architect, London, April 1975
7. "Registro Italiano Navale" letter No. 20663 to Mr. Rosenblatt & Son, Inc. dated Nov. 12, 1975.
8. "Quality Standards and Quality Control in Shipbuilding: A Joint Task of Shipyard and Classification Society", W. Santini, RINA, 1975.
9. "Rules for Non-Destructive Inspection of Hull Welds", American Bureau of Shipping, New York, 1975.
10. "Guide for Interpretation of Non-Destructive Tests of Welds in Ship Hull Structures," Weld Flaw Evaluation Committee, SSC-177, Ship Structure Committee, Washington, D.C., Sept. 1966.
11. "A Guide for Ultrasonic Testing and Evaluation of Weld Flaws" R.A. Youshaw, SSC-213, Ship Structure Committee, Washington, D.C., 1970.
12. "Rules for Building and Classing Steel Vessels", American Bureau of Shipping, New York, 1976.
13. "Radiographic Standards for Production and Repair Welds", NAVSHIPS 0900-003-9000.

14. "Code of Federal Regulations Title 46, Shipping"
Subchapter D of Chapter 1, October 1975.
15. "Production Standard of the German Shipbuilding Industry,"
Association of the German Shipbuilding Industry, Hamburg, November 1974.
16. "Accuracy in Hull Construction, VIS 530", Varvindustrins Standardcentral, Stockholm, 1976.
17. Full Penetration K-Welds or Double Fillet Welds in Heavy Shipbuilding", N.G. Leide, Structural Design and Fabrication in Shipbuilding, London, November 1975.
18. "Fillet Weld Costs versus Fit-Up Gaps"- Bath Iron Works Memorandum dated Feb. 19, 1976.
19. "Tolerances in the Prefabrication of Ships," Carl-Erik Fredriksson, Trans. RINA 1962, pp. 201.
20. "Structural Details Design Review", R. Glasfeld, Ship Structure Committee SSC-226, 1976
21. "Investigation of Technological Errors in Welded Ship Hulls Assembly Joints", Alferov & Matskevich, International Institute of Welding. Document XIII-761-74 (USSR), October 1974.
22. "Total Quality Control in Shipbuilding", Shimizu & Sugisaki, Nippon-Kokan Technical Report Overseas, Sept. 1965.
23. "A System of Dimensional Control for Ship's Structure" J.R. Salzer, MARAD Ship Producibility Program, April 1974.
24. "The Accuracy of 1/10th Scale Plate Drawings," J. S. Collinson, D. Adams and P. C. McConnell, BSRA 1967. Technical Memorandum No. 300
25. "Quality Control in Shipbuilding. 1st Report. Dimensional Accuracy of Steelwork," D.H.S. Bunn and W.G. Smith, BSRA 1968. Report NS238.
26. "Aspects of NDT Inspection of Welds in Shipbuilding with Particular Regard to Ultrasonic Testing", M. Papponetti, RINA, 1974.
27. "Welding Metallurgy - Iron and Steel", Claussen & Henry, American Welding Society, New York, 1949.
28. "Design of Welded Structures", Blodgett, James F. Lincoln, Arc Welding Foundation, 1966.

ACKNOWLEDGEMENT

During the many visits to shipowners/operators, shipyards, classification societies, and steel mills, the project investigators have received excellent cooperation and assistance from all. The names are too numerous to mention here; however, we would like to acknowledge all contributions to the project by each of the following organizations:

Shipyards and Steel Fabricating Facilities

American Bridge Div. (U.S. Steel)
Avondale Shipyards
Bath Iron Works
Bethlehem Steel Shipbuilding,
 - Beaumont, Texas
 - Sparrows Point, Maryland
Campbell Industries
FMC Corporation
General Dynamics Corporation, Quincy Yard
Galveston Shipbuilding (Kelso)
Levingston Shipbuilding
Litton Industries, Ingalls Shipbuilding
Marathon Le Tourneau, Gulf Marine Div.
National Steel Shipbuilding
Newport News Shipbuilding
Seatrain Shipbuilding
Sun Shipbuilding
Todd Shipyards
 - Houston, Texas
 - Los Angeles, California
 - Seattle, Washington

Chantiers de L'Atlantique, Paris, France
Götawerken, Gothenburg, Sweden
Howaldtswerke-Deutsche Werft, Hamburg-Kiel, Germany
Kockums Mekaniska Werkstad, Malmö, Sweden
Swan Hunter, Wallsend, Northumberland, England
Verolme United, Rotterdam, Holland

Ship Owners/Operators

Aries Marine
British Petroleum Company
Burmah Oil Tankers (Energy Transport)
Chevron Shipping
El Paso LNG Corporation
Exxon Corporation, Marine Division
Farrell Lines
Global Marine, Inc.
Gulf Oil Corporation
Lykes Brothers Shipping
Marine Transport Lines
Maritime Overseas Corporation
Mobil Shipping and Transportation Company
Prudential Lines
Sea-Land Services
States Steamship Company
United States Lines
Zapata Technical Services Corporation

Steel Producers

Armco Steel Corporation, Houston, Texas
United States Steel Corporation, Pittsburgh, Pennsylvania

Classification Societies

American Bureau of Shipping
Bureau Veritas
Lloyd's Register of Shipping
Nippon Kaiji Kyokai
Det Norske Veritas
Germanischer Lloyd
Registro Italiano Navale

Research Institutions

British Ship Research Association
Verband de Deutschen Schiffbau-Industrie
AB Svensk Varvsindustri

The authors would like to extend special thanks to the following institutions which have given official permission to the publication of their tolerance standards in this report:

- Bath Iron Works
- Ingalls Shipbuilding
- Levingston Shipbuilding
- Newport News Shipbuilding
- Seatrain Shipbuilding
- Sun Shipbuilding
- Nippon Kaiji Kyokai (and The Society of Naval Architects of Japan)
- Verband der Deutschen Schiffbau Industrie e.V.
- AB Svensk Varvsindustrins Standardcentral

We appreciate the contribution Mr. Isao Takeuchi of Nippon Kaiji Kyokai provided by partially translating the background document for the Japanese Shipbuilding Quality Standards.

We would also like to express our gratitude to all persons who have so graciously given us their time and attention.

Thanks are due Messrs. John Johnson and Frank Mei who have taken part in some of the surveys, and to Mr. Naresh Maniar both for his taking part in a number of surveys and for the general guidance he has provided in planning and executing the project as well as in preparing the final report.

9.0 APPENDIXES

9.1 BIBLIOGRAPHY

1. "Dimensional Control of Steelwork in Merchant Shipbuilding," V.E. Braid, BSRA.
2. "Japanese Shipbuilding Quality Standard (J.S.Q.S.) (Hull Part)" SNAJ Publication No. 8-2, Tokyo, 1975.
3. "Tolerances in the Prefabrication of Ships," Carl-Erik Fredriksson, Trans. RINA 1962, pp. 201.
4. "Quality Control in Shipbuilding. 1st Report. Dimensional Accuracy of Steelwork," D.H.S. Bunn and W.G. Smith, BSRA 1968. Report NS238
5. "Quality Control in Shipbuilding. 2nd Report. An Investigation into Erection and Fairing on the Berth," V.E. Braid, BSRA 1969. Report NS266
6. "The Deformation of a Ship's Hull Under Construction," M. Oda and Y.J. Kaziwara, SNAJ 1963-9, (BSRA Translations). Nos. 1894, 2073, 2139, 2272, 2375 & 2496.
7. "The Accuracy of 1/10th Scale Plate Drawings," J.S. Collinson, D. Adams and P.C. McConnell, BSRA 1967. Technical Memorandum No. 300
8. "Maritime Administration Research and Development, MacCutcheon, SNAME 1963 Transactions.
9. "Non Destructive Testing in Shipyard Environment," Lowe, SNAME Hampton Rd. 1971.
10. "Japanese Shipbuilding Practice," McQuade, Marine Technology Oct. 1969.
11. "The Marine Industry Measured for Size, Shape and Position," SNAME Gulf Coast, February 1969.
12. "Welding Problem in Shipbuilding, Masubuchi," Marine Technology, Jan. 1969.
13. "High Tensile Steel and the Fabrication," Grubb, SNAME Philadelphia, 1961.
14. "Reflection on 35 Years of Shipyard Welding," Dooley, SNAME Philadelphia, 1971.
15. "A Review of the Practical Application for Ultrasonic Inspection of Welds on Ship," Frank, SNAME S.E., October 1968.
16. "Recent Development in Shipyard Welding," McDermott, SNAME, Canadian Maritime, April 1965.

17. "A Rational Approach to Inspection and Testing of Engineering Weldments," Clough, SNAME, Pacific Northwest, October 1964. 35
18. "Thermal Analysis for Complex Structural Systems," Cox and Carneal, Marine Technology, October 1971. 36
19. "On the Flow Line of Assembly Blocks," Fujii and Yagi, SNAJ. 37
20. "The Continuous Flow Production System," Terai and Kurika, SNAJ. 38
21. "The Development of Quality Control in Shipbuilding," NECIE&S trans. 1967-1971. 1970. 39
22. "Effect of Flame and Mechanical Straightening on Material Properties of Weldments," SNAME, Ship Structure Committee SSC-207, 1970.
23. "Effect of Temperature and Strain Upon Ship Steel," SNAME, Ship Structure Committee SSC-235, 1973. 40
24. "Fabrication, Welding and Inspection of Ship Hulls," NAVSHIP 0900-000-1000. Naval Ship Systems Command, Washington, D.C., Oct. 1968
25. "Variation of Product Analysis and Tensile Properties of Carbon Steel Plates and Wide Flange Shapes," AISI 1974. 41
26. "Bonded Joints and Non-Destructive Testing. NDT of Resistance Spots, Roll-Spot, Stitch and Seam Welds," Hall and Crecraft, IPC Science and Technology Press, Ltd., Surrey, England, 1971. 42.
27. "Influence of Thermal Cutting and Its Quality on the Fatigue Strength of Steel," F. Goldberg, AWS 1973. 43.
28. "Control of Distortion in Welded Fabrication," Welding Institute, Cambridge, England, 1968. 44.
29. "Specifications of Permissible Defect Sizes in Welded Metal Structures," A.A. Wells, Queen's University, Belfast, Brighton, England, 1969. 45.
30. "Weld Imperfections. Identification and Interpretation," R.P. Meister, Symposium on NDT of Welds and Material Joining, 1968. 46.
31. "A Plan for NDT," D. Birchon, Brit. Jour. of NDT, Essex, England, 1970. 47.
32. "Production Standard of the German Shipbuilding Industry," Association of the German Shipbuilding Industry, Hamburg, November 1974. 48.
33. "Alignment Investigation Following a Crankshaft Failure in a Medium-Speed Diesel Engine," Castel, SW&S October 1970. 49.
34. "An Investigation of Major Variables in Conventional Tailshaft Assembly," Calamari, Marine Technology, October 1964.

35. "Measurement of Bull Gear and Line Shaft Bearing Alignment During Operation," Lerro, SNAME Philadelphia, 1963.
36. Considerations in the Design of Marine Propulsion Shafting Systems," Lehr, SNAME N. England 1961 - p. 555.
37. "A Study of Accuracy Control in Hull Construction Works," Takeshi Yokota & Taizo Shimoura, BSRA Translation No. 1861 (1963)
38. "Vibration Analysis & Deviation Concept, VIDEK," Dickinson, SNAME Gulf Section. Sept. 1971.
39. "Ultimate Strength of Square Plates Subjected to Compression; First Report on the Effects of Initial Deflection and Welding Residual Stresses", Y, Ueda et al., Journal of SNAJ, Vol. 137, June 1975.
40. "On the Strength of Structures with Imperfections; Second Report" Buckling Collapse of Girders with Initially Deflected Corners". Fujita, Yoshida, and Takazawa, JSNAJ, Vol. 137, June 1975.
41. "Stress Intensity Factors of Cracks Emanating from Side Notches in Plates", Tamamoto, Sumi, and Ao, JSNAJ, Vol. 137, June 1975.
42. "A Preliminary Study on Surface Crack Growth in a Combined Tensile and Bending Fatigue Process", Kawahara & Kurihara, JSNAJ, Vol. 137, June 1975.
43. "Difference in Low Cycle Fatigue Strength by Strain Controlled Axial Load and Deflection Controlled Bending Load", Iida, Matsumoto, & Nagai, JSNAJ, Vol. 137, June 1975.
44. "On Fatigue Damage of Web Stiffeners at Cutouts of Bottom Transverses", H. Mano et al., JSNAJ, Vol. 137, June 1975.
45. "Strength Analysis of Shell Structure with Stiffeners by Finite Strip Method - Second Report", N. Fukuchi, JSNAJ, Vol. 137, June 1975.
46. "Bending of a Wide and Thick Mild Steel Plate - Third Report", Yagi, Funaki, & Kada, JSNAJ, Vol. 137, June 1975.
47. "Studies on Deformation and Cracking in One-Sided Welding - Second Report", K. Satak, et al., JSNAJ, Vol. 137, June 1975.
48. "The Acceptability of Weld Defects", Harrison and Young, The Naval Architect, April 1975.
49. "Structural Problems In Methane Carriers" B. Javelle and J. Raynaud (of Bureau Veritas), Shipping World & Shipbuilder, Sept. 1975, pp. 831.

50. "Third Decade of Research Under the Ship Structure Committee"
Chazal, Goldberg et al. SNAME Ship Structure Symposium Paper.
October 1975
51. "Classification Society Experiences in Today's Ships"
William M. Hannan. SNAME SS Symposium October 1975
52. "Structural Considerations In the Design of the Polar Class of
Coast Guard Icebreakers", Barker et al., SNAME SS Symposium,
October 1975
53. "Unusual Hull Design Requirements, Construction and Operating
Experience of the Barge Carriers". Thayer & Schwendtner, SNAME
SS Symposium, October 1975
54. "Yesterday's Technology -Today's Ships - Some Tanker Experience",
Szostak, SNAME SS Symposium October 1975
55. "Structural Design Criteria for the Safe and Economical Trans-
portation of LNG" - Shumaker & Hay, SNAME, October 1975
56. "Observation of Ship Damage over the Past Quarter Century" -
Townsend, SNAME SS Symposium, October 1975
57. "Dynamic Loadings Due to Waves and Ship Motions"- Lewis & Zubaly,
SNAME SS Symposium - October 1975
58. "Structural Response & Computer - Aided Design Procedure", Stiansen,
SNAME SS Symposium, October 1975
59. "An Assessment of Current Shipboard Vibration Technology", Noonan.
SNAME SS Symposium, October 1975
60. "Fracture Mechanics, Fracture Criteria and Fracture Control for
Welded Steel Ship Hulls", Rolfe, SNAME SS Symposium, October 1975
61. "An Overview of Structural Integrity Technology", Palermo, SNAME
SS Symposium, October 1975
62. "Fundamental Considerations of Fatigue, Stress-Corrosion Cracking,
and Fracture In Advanced Ship Structures". Crooker et al., SNAME
SS Symposium - October 1975
63. "Analysis and Design Requirements", - Wilson, SNAME SS Symposium,
October 1975.
64. "Experimental Methods In Ship Structural Evaluation", Dinsbacher,
SNAME SS Symposium October 1975
65. "Joining Technology and Quality Control" - Manley, SNAME SS Symposium
October 1975.

66. "Ship Structural Analysis in Lloyd's Register of Shipping".
The Naval Architect, July 1975.
67. "The Statistical Approach to Hull Design", Prof. D. Faulkner,
The Naval Architect, July 1975.
68. "A Study of Sub-Critical Crack Growth in Ship Steels", Francis,
Lankford & Lyle, SSC-251, 1975.
69. Full Penetration K-Welds or Double Fillet Welds in Heavy Ship-
building", N.G. Leide, Structural Design and Fabrication in
Shipbuilding, London, November 1975.
70. "Finding Flaws by Ultrasonics", Marine Engineering/Log, November 1974.
71. "Materials for Ocean Engineering", K. Masubuchi, MIT Press, Cambridge
1970.
72. "Design of Welded Structures", Blodgett, James F. Lincoln. Arc Welding
Foundation, 1966.
73. "The World's Largest Offshore Mobile Drilling Unit", Surveyor, American
Bureau of Shipping, August 1976.
74. "Welding Metallurgy - Iron and Steel", Claussen & Henry, American Weld-
ing Society, New York, 1949.
75. "Ship Design and Construction", D'Arcangelo, SNAME, New York, 1969.
76. "A Guide to Sound Ship Structures", D'Arcangelo, Cornell Maritime Press.
Cambridge, Maryland, 1964.
77. "Steel Construction Manual", American Institute of Steel Construction,
1975.
78. "Application of Probabilistic Concepts for Determining Limits
of Initial Imperfection of Ship Plating", Yasukawa, Ikegami, & Ominami,
Journal SNAJ, Vol. 138, December 1975.
79. "Numerical Control of High Speed Cutting Boosts Productivity",
R. L. Bullard, Marine Engineering/Log, March 1975.
80. "General Specifications for Ships of the United States Navy - Section 100:
General Requirements for Hull Structure" January 1973.
81. "Dimension Accuracy Control in the Construction of Welded Ships".
Morten Ringard, PH.D Thesis, MIT, January 1974.

82. "Fabrication Factors Affecting Structural Capability of Ships and Other Marine Structures" Report of Committee III.3, 6th International Ship Structures Congress, Boston, 1976.
83. "Japanese Shipbuilding Quality Standards - Background Document." SNAJ Publication No. 8-3, Tokyo, July 1976.
84. "Accuracy in Hull Construction, VIS 530", Varvindustrins, Standard-central, Stockholm, 1976..
85. "Alternative Methods of Non-Destructive Testing" Research Report by Lockheed Shipbuilding Corp., SNAME.
86. "Building and Operating Experience of Spherical Tank LNG Carriers" Howard, Kvamsdal, & Naesheim, SNAME New York Section Paper, Sept. 1976.
87. "Investigation of Technological Errors in Welded Ship Hulls Assembly Joints", Alferov & Matskevich, International Institute of Welding- Document XIII-761-74 (USRR), October 1974.
88. "Registro Italiano Navale" letter No. 20663 to M. Rosenblatt & Son, Inc. dated Nov. 12, 1975.
89. "Quality Standards and Quality Control in Shipbuilding: A Joint Task of Shipyard and Classification Society", W. Santini, RINA, 1975.
90. "Rules for Non-Destructive Inspection of Hull Welds", American Bureau of Shipping, New York, 1975.
91. "Guide for Interpretation of Non-Destructive Tests of Welds in Ship-Hull Structures," Weld Flaw Evaluation Committee, SSC-177, Ship Structure Committee, Washington, D.C., Sept. 1966.
92. "A Guide for Ultrasonic Testing and Evaluation of Weld Flaws" R.A. Youshaw, SSC-213, Ship Structure Committee, Washington, D.C., 1970.
93. "Rules for Building and Classing Steel Vessels", American Bureau of Shipping, New York, 1976.
94. "Aspects of NDT Inspection of Welds in Shipbuilding with Particular Regard to Ultrasonic Testing", M. Papponetti, RINA, 1974.
95. "Code of Federal Regulations Title 46, Shipping", Subchapter D of Chapter I, October 1975.
96. "A System of Dimensional Control for Ship's Structure" J.R. Salzer, MARAD Ship Producibility Program, April 1974.

97. "Fillet Weld Costs versus Fit-Up Gaps" - Bath Iron Works Memorandum dated Feb. 19, 1976.
98. "Structural Details Design Review", R. Glasfeld, Ship Structure Committee Project SR-216, Preliminary Report, 1975.
99. "Total Quality Control in Shipbuilding", Shimizu & Sugisaki, Nippon-Kokan Technical Report Overseas, Sept. 1965.
100. "Photogrammetry in Shipbuilding", J. F. Kenefick. First Draft of Final Report to MARAD Photogrammetry Project, Feb. 1976.
101. "Detail Design in Ships" Lloyd's Register of Shipping, London, October 1967.
102. "Radiographic Standards for Production and Repair Welds", NAVSHIPS 0900-003-9000.

9.2: U. S. COMMERCIAL SHIPYARD STANDARDS

CONTENTS

<u>APPENDIX</u>	<u>DESCRIPTION</u>	<u>PAGE</u>
9.2.1	: Bath Iron Works	
	9.2.1.1: B.I.W. Inspection Guidelines	9-9
	9.2.1.2: Ro/Ro Dimensional Control Guidelines	9-12
9.2.2	: Litton Industries (Ingalls Shipbuilding) Sample "Manufacturing Standard Process"	9-15
9.2.3	: Levingston Shipbuilding Special Tolerances for Drill Rig	9-20
9.2.4	: Newport News SB&DD Dimensional Tolerances for LNG Tanker	9-23
9.2.5	: Seatrain Shipbuilding Structural Tolerances	9-24
9.2.6	: Sun Shipbuilding and DD Shipbuilding Production Standard (Hull Division)	9-26
9.2.7	: Tables of Permissible Unfairness in Welded Structure (from NAVSHIPS 0900-000-1001)	9-62

Note: The following are reprinted with special permission from the respective organizations.

BIW INSPECTION GUIDELINES

MATERIAL

A. SURFACE CONDITIONS

1. ALL PLATES AND SHAPES MUST MEET SURFACE CONDITIONS OF ABS RULES. SCARS IMPERFECTIONS ARE TO BE AVOIDED IN ALL AREAS OF SHIPS STRUCTURE. SPECIAL CONSIDERATIONS OF THESE REQUIREMENTS SHALL BE DIRECTED TO LONGITUDINAL AND TRANSVERSE STRENGTH STRUCTURE AS INDICATED BELOW. NOTCHES SHALL BE AVOIDED.
 - a. LONGITUDINAL PLATES AND SHAPES IN MIDSHIPS 3/5 LENGTH.
 - b. UPPER "A" DECK PLATING, TANK TOP "F" DECK PLATING.
 - c. SHELL PLATING.
 - d. BOX GIRDERS.
 - e. LONGITUDINALS AND ALL DECK STRINGER PLATES.
 - f. TRANSVERSE WEB FRAMES.
 - g. LONGITUDINALS AND TRANSVERSE BULKHEADS AND ATTACHMENTS.
 - h. PILLARS.
1. ALL DECK CUTOUTS.
2. REPAIRS TO SCARS AND IMPERFECTIONS OF MEMBERS INCLUDED IN PARA. A-1 ABOVE MUST BE MADE BY GRINDING, CHIPPING OR WELDING DEPENDING ON MAGNITUDE OF IMPERFECTION OUTLINED AS FOLLOWS:
 - a. IN GENERAL, MINOR SCARS MAY BE REPAIRED BY GRINDING.
 - b. SCARS WHICH EXCEED 3/32" IN DEPTH AND 1" IN LENGTH SHALL BE REPAIRED BY CHIPPING, GRINDING AND WELDING.
 - c. REPAIR WELDS WHICH ARE GENERALLY LOW IN PROFILE (3/32") AND ARE NOT AN APPEARANCE FACTOR NEED NOT BE GROUND.
3. SCARS IN NON-STRENGTH AREAS
 - a. WHERE APPEARANCE IS IMPORTANT, SCARS MAY BE REPAIRED AND DRESSED BY USING AN APPROVED EPOXY COMPOUND.
 - b. WHERE APPEARANCE IS NOT IMPORTANT, MINOR SCARS WILL NOT REQUIRE REPAIR OR TREATMENT.

FITTING

A. MISALIGNMENT AND FIT-UP

1. MISALIGNMENT MEASUREMENT -

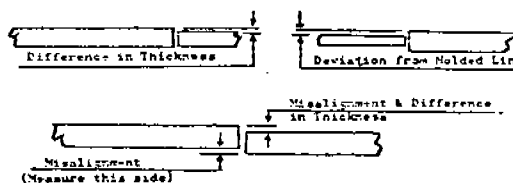

2. MISALIGNMENT AND FIT-UP BUTTS -

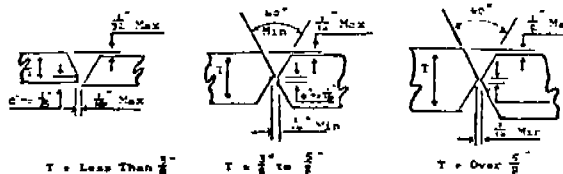

3. MAXIMUM MISALIGNMENT OF WEBS, FLANGES AND FACE PLATES -

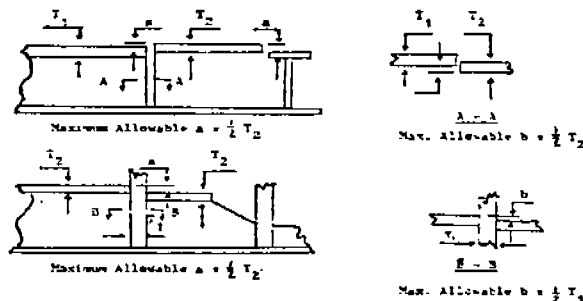

4. ANY MISALIGNMENT EXCEEDING THE TOLERANCES SHOWN WILL BE INSPECTED AND RESOLVED ON A CASE BASIS BY THE BIW INSPECTION DEPARTMENT.
5. WHEN A MISALIGNMENT EXISTS ADDITIONAL WELD REINFORCEMENT SHALL BE APPLIED TO MISALIGNED MEMBERS FOR ADDITIONAL STRENGTH OF MISALIGNED MEMBERS AS NECESSARY.

FITTING

B. FAYING SURFACES

1. CLEARANCE BETWEEN FAYING SURFACES OF LAP JOINTS AND PERMANENT INSTALLED BACKING BAR BUTT JOINTS SHALL NOT EXCEED 1/16" EXCEPT AS SPECIFIED ON PLANS. DOES NOT APPLY TO RIVETED HUCK BOLTED JOINTS.

C. PENETRATIONS

1. PLANS ARE TO BE CROSS CHECKED WITH CONCERNED DEPARTMENTS PRIOR TO MAKING CUTS SO ELECTRICAL, PIPE AND VENTILATION PENETRATIONS CAN BE MINIMIZED.

D. FILLET GAP

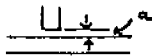

$a \approx 1/16"$ acceptable.
 $1/16" < a \approx 3/16"$ increase fillet leg by "a".

$a > 3/16"$ full penetration weld required or correct by (must be approved by BIW Inspectors):

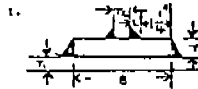

$$T_1 > T_2$$
$$g = T_2 + 2(L - \frac{1}{4})$$

2.

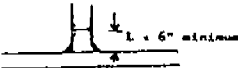

E. PLATE EDGE BUILD-UP

1. PLATE EDGE BUILD-UP WHERE PERMITTED WILL BE IN STRICT ACCORDANCE WITH ABS RULE REQUIREMENTS AND WITH CONCURRENCE OF OWNERS AND REGULATORY BODIES. BUILD-UP TO BE WITH TYPE OF FILLER METAL SPECIFIED BY WELDING PROCEDURE.
2. WHERE PLATE EDGE BUILD-UP IS EMPLOYED FOR A FIX, THE JOINT IS TO BE FULLY PREPARED AND INSPECTED PRIOR TO RELEASE FOR FINAL PRODUCTION WELDING. TO COMPLY WITH ABS RULES, ARC STRIKES ARE TO BE AVOIDED.

F. FIT-UP RESOLUTION

1. IN ALL CASES WHERE STRUCTURE MAKE-UP CLEARANCE EXCEED PLATE THICKNESS, WORK SHALL NOT PROCEED UNTIL RESOLVED BY BIW INSPECTION DEPARTMENT. THE AGREED FIX WILL BE PERFORMED WITHOUT DEVIATION.

WELDING

- A. WELDING MATERIALS SHALL BE DISPENSED WITH UTMOST CARE. ONLY THOSE ELECTRODES WHICH ARE COMPATIBLE WITH DESIGNATED MATERIALS SHALL BE USED IN ACCORDANCE WITH APPLICABLE WELDING PROCEDURE. SUBSTITUTION OF WELDING MATERIAL IS NOT PERMITTED WITHOUT PRIOR APPROVAL OF WELDING ENGINEER.

- B. ERROR IN USE OF WELDING MATERIALS IS CAUSE FOR REJECTION OF UNIDENTIFIED WORK IN PROCESS.

- C. POSITIVE RELATION SHALL BE ESTABLISHED BETWEEN PARENT METALS AND FILLER WELD METALS ON ALL IN PROCESS WORK. ONLY APPROVED ELECTRODES WILL BE USED FOR TACK OR BLOCK WELDING. (IF, IN ERROR, WELD METAL IS DEPOSITED WHICH IS CONTRARY TO APPROVED WELDING PROCEDURE, WELD METAL SHALL BE REMOVED IN ITS ENTIRETY AND THE CONCERNED AREA INSPECTED PRIOR TO REWELDING.)

- D. WELDS SHALL BE FREE OF CRACKS OR CRACK-LIKE INDICATIONS OR LINEAR INDICATIONS.

- E. THE HEIGHT OF REINFORCEMENT OF A BUTT WELD OR SEAM SHALL BE KEPT TO A MINIMUM IN THE FOLLOWING AREAS:

1. EXTERIOR SHELL.
2. EXPOSED AREAS OF WEATHER DECKS.
3. EXTERIOR SIDES OF DECK HOUSES.
4. ON DECKS THAT HAVE A COVERING: WELD REINFORCEMENT SHOULD BE 1/16" NOT TO EXCEED 3/32".

- F. SIZE OF WELDS SHALL BE UNIFORM TO REQUIRED SIZE AND CHECKED WITH A WELD GAUGE.

G. FILLET WELDS FOR STRUCTURE

1. UNDERCUT AT WELD EDGE IN EXCESS OF 1/32" WILL BE REPAIRED BY WELDING. UNDERCUT TO BE MINIMIZED BY PROPER WELDING TECHNIQUE.

- H. WHERE APPEARANCE IS A CONCERN OR CRITERIA FOR ACCEPTANCE OR REJECTION THAN ATTACHMENT AND PLACEMENT OF RESTRAINTS (WELDING OF STRONGBACKS) SHOULD BE CONSIDERED SO THE LEAST AMOUNT OF COSMETIC WORK WILL BE REQUIRED AFTER THE REMOVAL OF THE RESTRAINTS.

I. WELDING POROSITY

1. VISIBLE WELDING POROSITY SHALL NOT BE ACCEPTABLE AT OIL TIGHT OR WATER TIGHT BOUNDARIES. NON-TIGHT BOUNDARIES MAY BE CORRECTED BY FILLING WITH FORTIFIED EPOXY COMPOUND PRIOR TO COATING. IN OTHER AREAS POROSITY SHALL BE ACCEPTABLE PROVIDED THERE ARE NOT INDICATIONS GREATER THAN 3/32" DIAMETER, WITH NO MORE THAN (4) INDICATIONS IN ANY 6" LENGTH OF WELD.

WELDING

- I. WELDING POROSITY (CONT.)
 2. ELONGATED GAS HOLES LESS THAN 1/2" LENGTH AND 1/16" IN WIDTH ARE ACCEPTABLE IN NON-WATER TIGHT & NON-STRUCTURAL ATTACHMENT FILLET WELDS. SHOULD A GENERAL POROUS CONDITION EXIST IN ANY AREA, THE CONDITION SHALL BE CORRECTED.
- J. OVERLAP
 1. OVERLAP AT WELD EDGES SHALL BE REPAIRED BY WELDING OR GRINDING TO CREATE A SMOOTHLY FAIRED WELD EDGE.
- K. SNIPES
 1. BALLAST TANKS, WATER TANKS, BILGE AREAS AND WEATHER DECK AREAS SHALL BE COMPLETELY SEAL WELDED. SNIPES REQUIRED FOR DRAINAGE SHALL BE SIZED SUITABLY TO EFFECT COMPLETE SEAL WELDING.
- L. WELDING QUALITY
 1. LEADINGMEN SHALL INSPECT BACK GOUGING PRIOR TO AUTHORIZING BACK WELDING.
 2. MEMBERS TO BE WELDED SHALL BE INSPECTED FOR ACCEPTABLE FIT UP PRIOR TO COMMENCEMENT OF WELDING. FAULTS SHALL BE CORRECTED PRIOR TO PRODUCTION WELDING.
 3. APPROVED SEQUENCE WELDING AS OUTLINED IN APPROVED WELDING PROCEDURE SHALL BE STRICTLY ADHERED TO.
 4. REJECTABLE WELDING SHALL BE PROMPTLY DEALT WITH AS NECESSARY TO PRODUCE A FINISHED PRODUCT WHICH MEETS APPLICABLE RULES.
 5. RECORDS OF WELDOR QUALIFICATIONS AND JOINT PENETRATIONS FOR HULL WELDING SHALL BE MAINTAINED AND MADE AVAILABLE TO CONCERNED PARTIES.

FAIRNESS

- A. FAIRNESS OF ALL WELDED STRUCTURE SHALL CONFORM TO FIGURE 7A.

FAIRNESS

- B. STRUCTURES NOT IN CONFORMANCE WITH FIGURE 7A SHALL BE STRAIGHTENED BY APPROVED METHODS TO MEET FAIRNESS CRITERIA.
 1. WHERE HEATING AND SHRINKING IS EMPLOYED FOR STRAIGHTENING EXCESSIVE TEMPERATURES ARE TO BE AVOIDED.
 - 1400°F - MAX. MED. CARBON STEEL (DULL RED COLOR)
 - 1250°F - MAX. HTS - AH, DH AND EH
 2. MINOR DAMAGES INCURRED TO PLATE EDGES, ETC. WHICH REQUIRE STRAIGHTENING BY LOCAL HEATING SHALL NOT BE QUENCHED.
 3. VISIBLE DEFORMITIES SHALL BE DEALT WITH AS REQUIRED PRIOR TO ASSEMBLY.
 4. STRAIGHTENING BY THE USE OF HEAT SHALL NOT BE EMPLOYED ON STRINGER AND SHEAR STRAKE PLATING WITHIN 3/5 MIDSHIP LENGTH.
 5. IN GENERAL, STRAIGHTENING OF HTS BY USE OF HEAT SHALL BE KEPT TO A MINIMUM.
- C. STRUCTURAL DISTORTIONS
 1. SURVEYORS ARE TO BE USED TO ESTABLISH WORKING LINES AND WILL VERIFY PERIODICALLY THAT SHAPE AND SIZE IS BEING MAINTAINED.
 2. DURING THE COURSE OF MANUFACTURE WHEN DISTORTIONS OCCUR AS A RESULT OF WELDING OR UNDUE FORCE BEING APPLIED TO ESTABLISH SHAPE: FABRICATION SHALL NOT PROCEED UNTIL NECESSARY CORRECTIONS ARE ACCOMPLISHED. USE OF WELDING SEQUENCE, FITTING RESTRAINTS AND RESHAPING WILL BE EMPLOYED TO ENSURE THAT UNITS/SUB-UNITS WILL NOT HAVE DISTORTIONS PRIOR TO LEAVING HARDINGS' PANEL SHOP OR ASSEMBLY BUILDING.

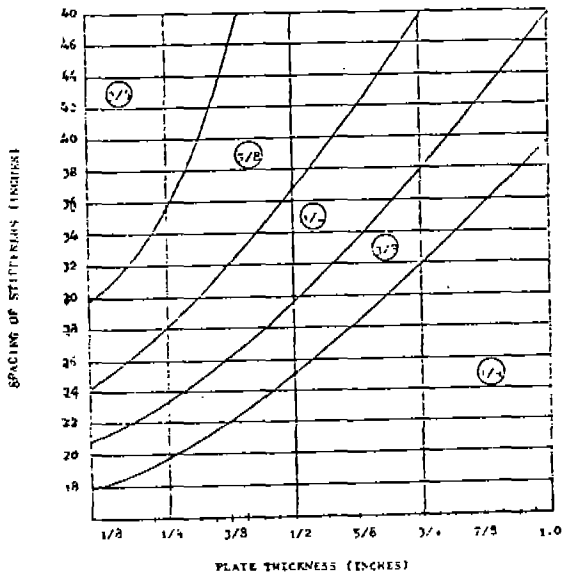

RO/RO
DIMENSIONAL
CONTROL
GUIDELINES

NOV. 1974

APPENDIX: 9.2.1.2

BATH IRON WORKS

GENERAL NOTES

2.1 RESPONSIBILITY:

- A. THE SHIPFITTERS SHALL ACCOMPLISH ALL WORK IN GENERAL ACCORDANCE WITH THESE GUIDELINES; SHALL BE AWARE OF AND TAKE CORRECTIVE ACTION FOR UNSATISFACTORY ITEMS; AND SHALL ACCOMPLISH ALL LAYOUT AND DIMENSIONAL CHECKS THAT CAN REASONABLY BE DONE WITHOUT SURVEYORS.
- B. THE SURVEYORS SHALL ASSIST THE SHIPFITTERS IN LAYOUT AND DIMENSIONAL CONTROL AS REQUIRED; SHALL REPORT ANY UNSATISFACTORY ITEMS FOUND TO SHOP SUPERVISION FOR CORRECTIVE ACTION; ON MAJOR UNITS SHALL RECORD ALL CRITICAL DIMENSIONAL CHECKS, SHALL TRANSFER CRITICAL REFERENCE LINES TO THE TOP SIDE OF THE UNIT FOR ERECTION, AND INSURE COMPLIANCE WITH THESE GUIDELINES PRIOR TO COMMENCEMENT OF MAJOR WELDING OR MOVING FROM THE ASSEMBLY POSITION.

2.2 ALL "WORKING DIMENSIONS" SHALL BE TAKEN FROM MOLD LOFT SKETCHES. WHERE IT IS NECESSARY TO USE DIMENSIONS FROM THE "BOOK OF OFFSETS" OR THE "MOLD LOFT INFO BOOK" A NEAT STOCK ALLOWANCE SHALL BE ADDED IN ACCORDANCE WITH ENCLOSURE (1). NOTE:

- A. UNITS 211, 301, 2, 3, 4 AND 5 HAVE 1" STOCK TO BE CUT TO 1/4" NEAT STOCK WHILE MARRIED.
- B. UNITS 221 AND 222 TO HAVE THE BOTTOM OF THE SHELL SET AT 1/4" NEAT STOCK.

2.3 THE 3'-0" BTK SHALL BE USED IN LIEU OF ϕ FOR THE MASTER REFERENCE AT PANEL, ASSEMBLY AND ERECTION FOR UNITS FR. 30-172 AS SHOWN ON ENCLOSURE (2). WHERE THE ϕ OR 3'-0" BTK CANNOT BE USED THE BTK USED SHOULD BE CLEARLY IDENTIFIED ON THE STRUCTURE.

2.4 ALL CRITICAL REFERENCES (ϕ , 3'-0" BTK, MASTER FRAMES, ETC.) SHALL BE CLEARLY CENTER PUNCHED AND OUTLINED AND IDENTIFIED ON THE STRUCTURE WITH BLACK PAINT OR MARKING PEN.

2.5 HARDINGS, THE PANEL SHOP AND HYDE SHALL RECORD DEVIATION FROM "WORKING DIMENSIONS" ON THE STRUCTURE WITH BLACK PAINT OR MARKING PENS. CRITICAL DIMENSIONS SUCH AS HALF WIDTHS SHALL BE RECORDED ON THE STRUCTURE AS "ACTUAL" VS. "WORKING DIMENSIONS" IN BLACK PAINT OR MARKING PEN.

2.6 ON MAJOR UNITS THE SURVEYORS ASSISTED BY THE SHIPFITTERS SHALL RECORD ALL CRITICAL DIMENSIONAL CHECKS ON THE "UNIT DIMENSIONAL RECORD" FORM, ENCLOSURES (3), (4) AND (5) OR A SPECIAL FORM FOR MORE COMPLEX UNITS.

2.7 ALL SUB-ASSEMBLIES, PANEL ASSEMBLIES AND UNITS SHOULD BE BUILT HOLDING ALL STRUCTURE TO THE 1ST WEB FRAME OR BULKHEAD FROM THE NEAT END. (THIS IS THE MASTER FRAME.)

2.8 ALL STRUCTURE SHALL BE HELD TO THE MOLD LOFT LAYOUT ON THE PERIPHERY OF THE UNIT AS FOLLOWS:

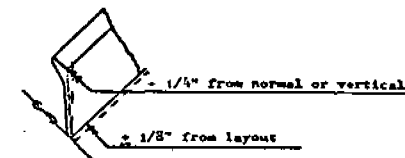

FR, L, C/L & BP Stiffeners

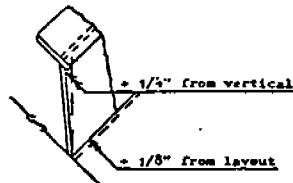

Girders, Webs & Stringers

HARDINGS

- 3.1 ALL MEASURING TAPES USED BY LAYOUT PERSONNEL SHALL BE CHECKED BIMONTHLY.
- 3.2 ALL F.B. AND SHAPE FABRICATION SHALL BE ACCOMPLISHED TO $\pm 1/8"$.
- 3.3 ALL FLAME PLANNER PLATES SHALL BE CHECKED AFTER BURNING TO $\pm 1/16"$.
- 3.4 TELEREX OUTPUT SHALL BE CHECKED TWICE A SHIFT FOR WIDTH AND LENGTH. RECTANGULAR PLATES SHALL BE HELD TO $\pm 1/8"$.
- 3.5 THE FOLLOWING CHECKS SHALL BE MADE AT SUB-ASSEMBLY:
 - A. LOCATION OF DIAPHRAGMS AND CHOCKS IN ϕ BOX GIRDERS AND PILLARS PRIOR TO INSTALLING THE CLOSING PLATE.
 - B. ALL BHDS. OR ASSEMBLIES BUILT TO LOFT SKETCHES SHALL BE CHECKED AND OVERALL DIMENSIONS HELD TO $\pm 1/4"$.
 - C. THE TRANSVERSE DECK BEAMS AFTER ASSEMBLY FOR CUTOUTS, CHOCKS AND FACE PLATE BEVELS. AFTER WELDING STRAIGHTEN IF NECESSARY TO HOLD $+3/8"$ OF CAMBER.
 - D. KNEE BRACKETS ON SHELL WEBS SHOULD BE INSTALLED AND HELD 1/4" HIGH TO MOLD LOFT TEMPLATES.
- 3.6 ALL SHAPED SHELL PLATES SHALL BE CHECKED FOR BACK SET AND TWIST AFTER FORMING TO MOLD LOFT COMMON BASE TEMPLATE.

PANEL SHOP

4.1 DECK ASSEMBLIES

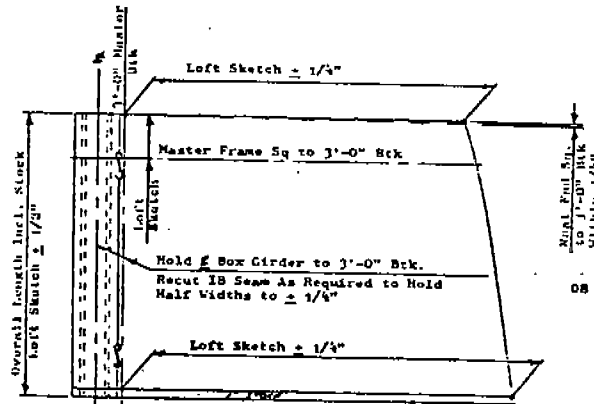

NOTE:

- A. PRIOR TO INSTALLATION, ESTABLISH THE MEAN ϕ OF THE ϕ BOX GIRDER - ANY DEVIATIONS FROM LOFT DIMENSIONS SHOULD BE NOTED FOR ADJUSTMENT OF THE LAYOUT ON P/S PANELS.
- B. PRIOR TO INSTALLATION OF THE ϕ BOX GIRDER, THE 3'-0" BTK SHALL BE ESTABLISHED FROM THE IB SEAM ALLOWING FOR THE BOX GIRDER CONDITION. THE HALF WIDTHS SHALL BE CHECKED ON THE FWD/AFT ENDS AND IF NOT WITHIN $\pm 1/4"$ THE 3'-0" BTK SHALL BE ADJUSTED AND THE IB SEAM RECUT.
- C. THE NEAT END SHOULD BE RECUT IF OUT OF SQUARE FROM THE 3'-0" BTK IN EXCESS OF $\pm 1/4"$.
- D. THE STOCK END SHOULD BE RECUT IF MORE THAN 1/4" OF STOCK EXISTS.
- E. THE LAYOUT FOR GRIDS SHOULD INCLUDE ALL BHDS., WEBS, ETC. FOR HYDE OR MAIN ASSEMBLY.
- F. THE O.B. EDGE SHOULD BE RECUT ONLY IF RECUTTING THE IB SEAM WILL NOT HOLD HALF WIDTHS TO $\pm 1/4"$.

SPECIAL NOTE:

UNIT 211 ϕ . P/S SHALL BE MARRIED IN THE INVERTED POSITION IN THE PANEL SHOP AND THE 1" OF STOCK LEFT BY THE LOFT RECUT TO HOLD 1/4" "NEAT STOCK" OVER LOFT DIMENSIONS.

PANEL SHOP (CONT.)

4.2 INNERBOTTOM ASSEMBLIES

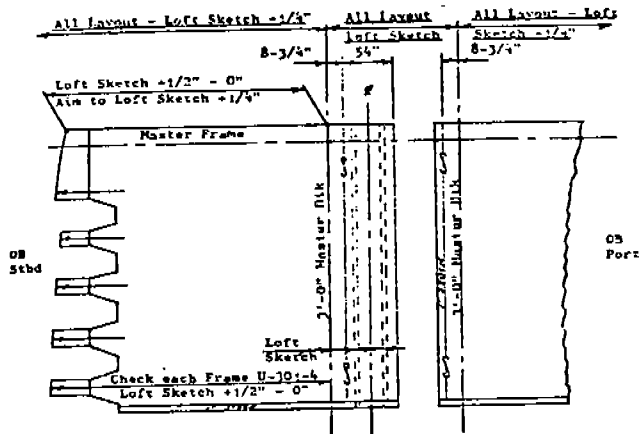

Units 301, 2, 3, 4 & 5 Only
Other Units Similar to Decks

INNERBOTTOM ASSEMBLIES TO BE HANDLED SIMILAR TO DECK EXCEPT AS FOLLOWS:

- A. UNITS 301, 2, 3, 4 AND 5 HAVE BEEN LOFTED WITH 1" OF STOCK P/S ON FLOORS AND 1" STOCK PORT ON T.T. THE LAYOUT IS TO BE ADJUSTED PER THE ABOVE SKETCH TO ADD 1/4" NEAT STOCK P/S AFTER ASSEMBLY. THE 1" OF STOCK WILL BE REMOVED BY SCRIBING THE BOX GIRDER AND THE P/S UNITS IN THE A.B.
- B. ON UNITS 301, 2, 3 AND 4 WHERE THE TANK TOP O.B. IS CUTOUT BETWEEN FLOORS HALF WIDTHS SHALL BE CHECKED AT EACH FRAME AND HELD TO +1/2" - 0" TO THE LOFT SKETCH (AIM TO LOFT DIMENSION +1/4").
- C. ON UNIT 201, FR. 172 1/2 - 188 1/2, USE THE 4'-6" BTK FOR THE MASTER BTK PORT.

4.3 MISC. PANEL ASSEMBLY

- 4.3.1 MISC. PANELS SHALL BE RESQUARED AND CHECKED TO LOFT DIMENSIONS PRIOR TO LAYOUT. NEAT EDGES SHALL BE RECUT WHEN THEY EXCEED LOFT DIMENSIONS BY 1/4" AND STOCK EDGES SHALL BE RECUT WHEN THEY EXCEED LOFT DIMENSIONS BY 1/2".

HYDE

5.1 SHELL ASSEMBLIES

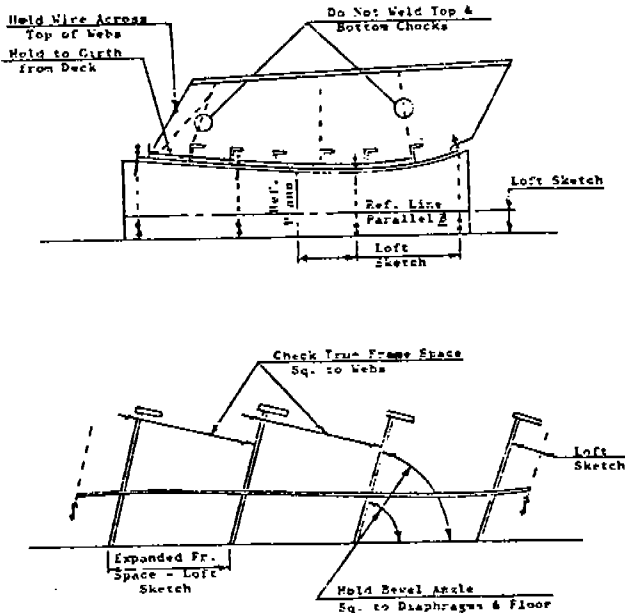

HYDE (CONT.)

5.1 SHELL ASSEMBLIES (CONT.)

PRIOR TO SETTING DIAPHRAGMS LAYOUT ALL SEAM AND WEB FRAME LOCATIONS ON PLATEN OR FLOOR: DURING ASSEMBLY CHECK THE FOLLOWING:

- A. UPPER AND LOWER SEAMS TO LOFT LAYOUT.
- B. FORE/AFT BUTTS TO LOFT SKETCH - RECUT NEAT AND IF OUT MORE THAN 1/4".
- C. WEB FRAME (AND ANY TRANSVERSE FRAME) LOCATIONS TO LOFT LAYOUT USING BEVEL ANGLE HELD SQUARE TO DIAPHRAGMS AND FLOOR - HOLD ALL WEBS (OR TRANSVERSE FRAMES) TO THE BEVEL ANGLE.
- D. HOLD WIRE ACROSS TOP OF WEBS TO HOLD DECK CUTS IN PLANE.
- E. TRUE FRAME SPACING SQUARE TO WEB PLATING.
- F. LAYOUT FORE/AFT ENDS USING GIRTH TAPES FROM DECK (OR THE "MOLD LOFT INFO BOOK") - HOLD ALL LONGITUDINALS NORMAL EXCEPT AS NOTED ON THE PLAN.
- G. DO NOT WELD THE TOP AND BOTTOM CHOCKS IN WEB FRAMES.

5.2 WING TANK ASSEMBLIES

- 5.2.1 WING TANKS NOT BUILT IN SHELL MOCKS SHALL BE BUILT ON LEVEL MOCKS ADJUSTED FOR PLATE THICKNESS VARIATIONS IN EXCESS OF 1/4". CARE MUST BE TAKEN IN SETTING WEBS TO BEVEL ANGLE IF MOCK BASE IS NOT PARALLEL TO 4.
- 5.2.2 LAYOUT SHELL LONGITUDINALS FROM DECK USING GIRTH TAPES (OR THE "MOLD LOFT INFO BOOK").
- 5.2.3 SHIPFITTERS SHALL REVERSE CRITICAL LINES (MASTER FRAME, RAMP LOCATION, ETC.) PRIOR TO MOVING FROM THE MOCK.
- 5.2.4 UNITS SHALL BE WELDED TO THE MAXIMUM EXTENT PRACTICABLE AND IN ALL CASES BLOCK TACKED ON THE OVERHEAD SIDE PRIOR TO MOVING OR TURNING. AFTER MOVING FOR TURNING OR FURTHER ASSEMBLY UNITS SHALL BE CHECKED FOR LEVEL.

ASSEMBLY SHOP

6.1 GENERAL NOTES

- 6.1.1 IT IS MOST IMPORTANT THAT UNITS BE ASSEMBLED IN A LEVEL CONDITION. ERRORS RESULTING FROM MAJOR FRAMING INTERSECTIONS (E. BOX GIRDER, L. & T. BMS., DECK/SHELL WEB INTERSECTIONS, ETC.) BEING OUT OF LEVEL CAN BE AS SERIOUS AS FAILURE TO HOLD MEMBERS PLUMB OR CHECK HALF WIDTHS. LEVEL PLATES OR SHIMS SHALL BE USED TO ADJUST FOR PLATE THICKNESS VARIATIONS IN EXCESS OF 1/4", AND WEIGHTS OR PULLING GEAR SHALL BE USED TO HOLD THE MAJOR FRAMING INTERSECTIONS WITHIN A UNIT TO ±1/4" FROM A MEAN PLANE. IN HEAVILY RESTRAINED UNITS SUCH AS INNERBOTTOMS WHERE IT IS NOT POSSIBLE TO HOLD ±1/4" A MEAN CONDITION IS TO BE ESTABLISHED AND THE CORNERS OF THE UNIT SHALL BE RESTRAINED WITH WELDED BRACES OR STEAMBOAT RATCHETS.
- 6.1.2 UNITS ARE TO BE ASSEMBLED ON SUBSTANTIAL AND RIGID MOCKS. DIAPHRAGM AND POST MOCKS ARE TO BE REPAIRED AND ADDITIONAL MEMBERS ADDED IF NECESSARY TO SUPPORT MAJOR FRAMING INTERSECTIONS. WHERE STEEL HORSES ARE USED THEY SHALL BE POSITIONED TO SUPPORT FRAMING INTERSECTIONS AND LEVELED WITH LEVEL PLATES PRIOR TO UNIT ASSEMBLY.
- 6.1.3 WITH THE UNIT LEVEL ON THE MOCK, THE SURVEYORS SHALL REVERSE CRITICAL REFERENCE LINES (E. MASTER BTK AND MASTER FRAME) TO THE TOP OF THE UNIT FOR ERECTION.
- 6.1.4 IN FITTING SHELL ASSEMBLIES THE FORE/AFT POSITION OF THE FIRST WEB FROM THE NEAT END SHOULD BE TAKEN AT ITS MID-HEIGHT IN ORDER TO SPILT ANY ERROR IN WEB LOCATION BETWEEN ASSEMBLY AND ERECTION.
- 6.1.5 BULKHEADS SHALL BE HELD TO THE LAYOUT TO ±1/8" AND SHALL BE HELD PLUMB AT INTERSECTIONS TO ±1/4" IN THEIR HEIGHT.

ASSEMBLY SHOP (CONT.)

6.1 GENERAL NOTES (CONT.)

6.1.6 "A" DECK UNITS 241, 242 and 141 HAVE A SHEER OF .3679" PER FOOT AND "B" AND "C" DECK UNITS 231, 232, 131, 221, 222 AND 121 HAVE A SHEER OF .5482" PER FOOT. THEY WILL BE BUILT ON LEVEL MOCKS AND CARE MUST BE TAKEN TO SET ALL BULKHEADS, SHELL ASSEMBLIES, PILLARS AND FOUNDATIONS TO THE PROPER DECLIVITY.

6.2 DECK/SHELL ASSEMBLIES

(SEE "UNIT DIMENSIONAL RECORD" FORM, ENCLOSURES (3) AND (4))

6.2.1 PILLARS SHALL BE SET TO HOLD THE BOTTOM TO A ±1/4" OF POSITION RELATIVE TO THE 3'-0" BTK AND THE MASTER FRAME. THIS SHALL BE MONITORED DURING WELDING AND WELD SEQUENCING SHALL BE USED TO CONTROL OR CORRECT DEVIATIONS.

6.2.2 SHELL ASSEMBLIES SHALL BE SET TO LOFT OFFSETS (PLUS NEAT STOCK) USING A BTK ESTABLISHED BY THE SURVEYORS. CARE MUST BE TAKEN TO MEASURE HALF WIDTHS FROM A NEAT CUT LINE ESTABLISHED BY CHECKING HEIGHTS FROM THE DECK AS IN SEVERAL SHAPED AREAS ERRORS IN HEIGHT CAN RESULT IN APPROXIMATELY EQUAL ERRORS IN HALF WIDTHS AS SHOWN BELOW:

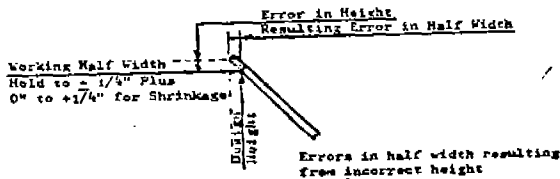

HALF WIDTHS (INCLUDING NEAT STOCK) SHALL BE HELD TO ±1/4" WITH AN ADDITIONAL 0 TO +1/4" ADDED FOR SHRINKAGE DEPENDING UPON THE SHAPE AND EXPERIENCE.

6.2.3 WING TANK ASSEMBLIES SHALL BE SET TO THE LONGITUDINAL BULKHEAD IN LIEU OF THE SHELL PLATING DUE TO THE POSSIBLE ERRORS OUTLINED ABOVE. THE LOWER EDGE OF THE BHD. SHALL BE HELD TO ±1/4".

6.2.4 SLOPING LONGITUDINAL BULKHEADS AND RAMPS SHALL BE SET TO THE "LOFT INFORMATION BOOK" (PLUS NEAT STOCK). THE ENDS OF RAMPS SHALL BE FITTED TO ±1/4" AND LEFT UNWELDED FROM THE ERECTION BUTT FOR 6'-0" OR THE NEAREST WEB FRAME, WHICHEVER IS LESS.

6.3 INNERBOTTOM UNITS

6.3.1 P/S INNERBOTTOM ASSEMBLIES, FR. 734 TO 2024, SHALL BE LEVELED USING THE AND THE O.B. GIRDER. UNITS FWD AND AFT OF THIS (UNITS 307, 401 AND 101) SHALL BE LEVELED USING THE T.T. O.B.

6.3.2 ON UNITS 301, 2, 3, 4 AND 5 THE P/S ASSEMBLIES AND BOX GIRDER SHALL BE SCRIBED IN USING THE 3'-0" BTK ESTABLISHED IN THE PANEL SHOP. (SEE SECTION 4.2 FOR ADJUSTMENT TO ADD 1/4" NEAT STOCK.) (IF THE P/S UNITS ARE NOT MARRIED IN THE A.B. LEAVE THE STOCK ON THE PORT SEAM TO BE CUT ON THE WAYS.)

6.3.3

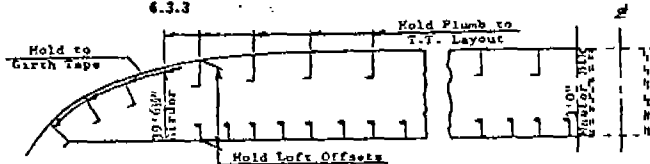

ASSEMBLY SHOP (CONT.)

6.3 INNERBOTTOM UNITS (CONT.)

6.3.3 (CONT.)

- A. IN FITTING SHELL HOLD PLATE GIRDERS AND SHELL LONGITUDINALS IB PLUMB TO THE TANK TOP LAYOUT. THE LONGITUDINALS O.B. OF THE 39'-6" GIRDER UNITS 301, 2, 3 AND 4 AND ALL LONGITUDINALS UNITS 307, 401 AND 402 ARE NORMAL AND SHALL BE LAID OUT WITH GIRTH TAPES PRIOR TO FITTING.
B. ON LONGITUDINALLY FRAMED UNITS CHECK HEIGHT OF EVERY 2ND LONGITUDINAL FROM THE TANK TOP (AFTER END ONLY) TO LOFT OFFSETS AND TEMPORARILY BRACE IF NECESSARY PRIOR TO SHELL INSTALLATION.

6.4 SPECIAL UNITS

6.4.1 COMPLEX "3-D" UNITS SHALL BE BUILT IN GENERAL ACCORDANCE WITH THE GUIDELINES OUTLINED FOR SIMILAR UNITS. PARTICULAR ATTENTION SHOULD BE PAID TO MELDING MAJOR STRUCTURE (DECK, BHD., SHELL, WING TANKS, STRINGERS, ETC.) TO PROPER HEIGHTS, HALF WIDTHS AND FORE/AFT POSITION AT THE ERECTION PLANES:

- EX: A. BOTTOM OF BHDS. FWD/AFT AND IB/OB ON UNIT 321.
B. DECK AND STRINGER HEIGHTS ON AFT END OF UNITS 404 AND 433.

6.4.2 UNIQUE DIMENSIONAL RECORD FORMS SHALL BE USED ON THE FOLLOWING UNITS:

Table with 2 columns: Unit Number and Description. Includes units 101 & 111, 201, 202 & 212, 102 & 122, 121, 142, 321 & 301, 402, 404, 433.

ERECTION

- 7.1 THE MASTER REFERENCES ESTABLISHED IN THE SHOP SHALL BE USED FOR REGULATING UNITS ON THE WAYS. IF MASTER LINES ARE NOT AVAILABLE, THEY SHOULD BE ESTABLISHED FROM DECK FRAMING. HEIGHTS OF DECKS AND FLATS AND FORE/AFT POSITION OF 1ST MAJOR WEB FROM THE NEAT END. (THE SHELL HALF WIDTH SHOULD NOT BE USED AS THIS INCLUDES THE ERROR RESULTING FROM PLATE BURNING, WELDING AND TRIMMING.)
7.2 THE SURVEYORS SHALL ESTABLISH THE MASTER ± OR 3'-0" BTK ON EACH DECK AS FITTING AND WELDING PROGRESSES TO HOLD IT.
7.3 DURING THE INITIAL ERECTION AND WELDING OF THE INNERBOTTOM THE KEEL CONDITION AND THE TANK TOP AT 21'-6" AND 39'-6" OFF SHALL BE CHECKED AND PLOTTED BIWEEKLY.
7.4 THE CONDITION OF THE RAMP RECESS IN "C" AND "D" DECK SHALL BE MONITORED DURING ERECTION AND HELD TO A MEAN PLANE ±1/4".
7.5 THE DECK OR TANK TOP CONDITIONS BELOW CARGO DOORS SHALL BE MONITORED DURING ERECTION. UNITS CONTAINING CARGO DOORS SHALL BE REGULATED IN ACCORDANCE WITH REFERENCE (8).
7.6 CARE MUST BE TAKEN TO HOLD DECK TO DECK HEIGHTS IN ERECTING UNITS 111, 411, 422, 432 AND 442 IN ORDER TO INSURE ALIGNMENT WITH MULTI-LEVEL UNITS FWD OR AFT.

ITE
1.
(a)
(b)
(c)
(d)
2.
3.
4.
5.

ACCEPTANCE CRITERIA

Module Integration

INGALLS SHIPBUILDING
 MANUFACTURING STANDARD
 PROCESS NO. 909-002

ITEM	DESCRIPTION	ACCEPTABLE TOLERANCES
1.	DEVIATIONS FROM THE MOLDED FORM, FOR THE COMPLETED HULL (AFTER WELDING MODULES TOGETHER) NOTE	
	THE FOLLOWING TOLERANCES ARE FROM NAVSHIPS 0900-000-1000 AND ARE ONLY TO BE USED FOR FINAL BUY OFF OF THE COMPLETED HULL: -	
(a)	BEAM OF HULL 0'-1000'-0" BEAM OF HULL OVER 100'-0"	$\pm 1''$ $+ 2, -1''$
(b)	LENGTH PER 100'-0"	$\pm 1''$
(c)	HALF BREADTH 0'-50'-0" HALF BREADTH OVER 50'-0"	$\pm 1/2''$ $\pm 1'', - 1/2''$
(d)	TWEEN DECK HEIGHTS MAX. ACCUMULATED DEVIATION; - FOR DK. HEIGHTS FROM BASELINE TO 50'-0" FOR DK. HEIGHTS ABOVE 50'-0"	$\pm 3/8''$ $\pm 1''$ $\pm 1 1/2'', -1''$
2.	THE DISTANCE BETWEEN THE END FRAMES, BULKHEADS OR FLOORS OF ANY TWO ADJACENT MODULES	$\pm 1/2''$
3.	ALIGNMENT OF MATING ENDS OF STIFFENERS, LONGITUDINALS AND GIRDERS	1/2 THICKNESS OF THE THINNER MEMBER
4.	ALIGNMENT OF DISCONTINUOUS MEMBERS ON OPPOSITE SIDES OF A THROUGH MEMBER.	1/2 THICKNESS OF THE THROUGH MEMBER. FOR STRUCTURAL SHAPES BOTH FLANGE AND WEB ARE TO FALL IN THIS LIMIT.
5.	PLATING FAIRNESS	SEE APPENDIX 'A'

AND SHELL
 TOP LAYOUT.
 6" GIRDER
 TUDIALS
 ND SHALL BE
 FITTING.

K HEIGHT OF
 K TOP (AFTER
 RARILY BRACE
 ATION.

NERAL ACCORD-
 ILAR UNITS.
 LDING MAJOR
 S, STRINGERS,
 FORE/AFT

OB ON UNIT

T END OF

E USED ON THE

301

SHALL BE USED
 INES ARE NOT
 K FRAMING,
 ON OF IST
 IDTH SHOULD
 NG FROM PLATE

2'-0" BTK ON
 HOLD IT.

INNERBOTTOM
 AND 39'-6"

DECK SHALL
 IN PLANE $\pm 1/4''$.

RS SHALL BE
 RGD DOORS
 (8).

IN ERECTING
 SURE ALIGN-

Module Assembly

(Assembly to Assembly Interface)

ITEM	DESCRIPTION	ACCEPTABLE TOLERANCE
1.	MODULE LENGTH	+1" in 100'-0" SEE APPENDIX 'B'
2.	MODULE HALF BREADTHS	+1/4"
3.	BULKHEADS BETWEEN DECKS, TOP TO BOTTOM OFFSET FROM VERTICAL	1/4"
4.	PLATE EDGE ALIGNMENT PLATE THICKNESS 0 to 3/8" PLATE THICKNESS OVER 3/8"	+1/16" +1/8"
5.	PLATING FAIRNESS	SEE APPENDIX 'A'
6.	ALIGNMENT OF MATING ENDS OF STIFFENERS, LONGITUDINALS, FLOORS, ETC.	1/2 THICKNESS OF THE THINNER MEMBER
7.	ALIGNMENT OF DISCONTINUOUS MEMBERS ON OPPOSITE SIDES OF A THROUGH MEMBER	1/2 THICKNESS OF THE THROUGH MEMBER. FOR STRUCTURAL SHAPES BOTH FLANGE AND WEB TO FALL IN THIS LIMIT

Structural Assemblies

ITEM	DESCRIPTION	ACCEPTABLE TOLERANCE
1.	OVERALL LENGTH AND WIDTH	$\pm 1/2''$ in 50'-0" USE APPENDIX 'B' FOR LENGTHS AND WIDTHS ABOVE 50'-0"
2.	HEIGHT-INNER BOTTOM OVERALL HEIGHT - ELSEWHERE (INCLUDES INN. BTM.)	$\pm 1/4''$ $\pm 1/2''$
3.	PLATE EDGE ALIGNMENT PLATE THICKNESS 0 to 3/8" PLATE THICKNESS OVER 3/8"	$\pm 1/16''$ $\pm 1/8''$
4.	ALIGNMENT OF MATING ENDS OF STIFFENERS, LONGITUDINALS, FLOORS, ETC.	1/2 THICKNESS OF THE THINNER MEMBER
5.	BULKHEADS BETWEEN DECKS, TOP TO BOTTOM OFFSET FROM VERTICAL	1/4"
6.	PLATING FAIRNESS	SEE APPENDIX 'A'
7.	BOWS IN PRIMARY STRUCTURE (FRAMES, BEAMS & STIFFENERS) WHERE SPAN IS DISTANCE BETWEEN THE SUPPORTS & DEPTH IS DEPTH OF MEMBER FROM UNDERSIDE OF FLANGE	$\frac{\text{SPAN (FEET)}}{\text{DEPTH (INCHES)} \times 4}$

MSP 909-002

APPENDIX "A"

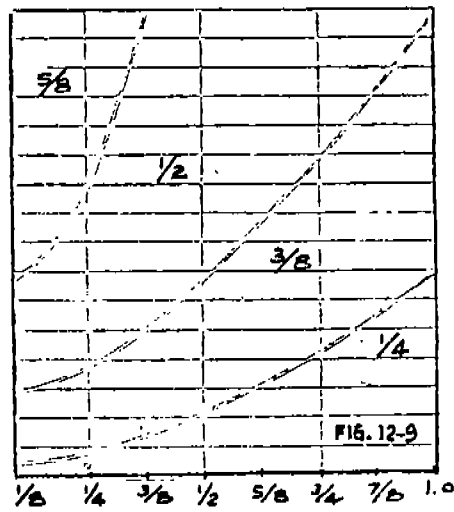
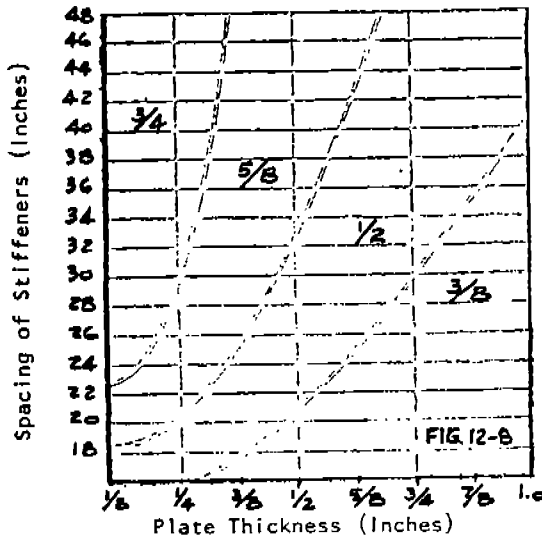
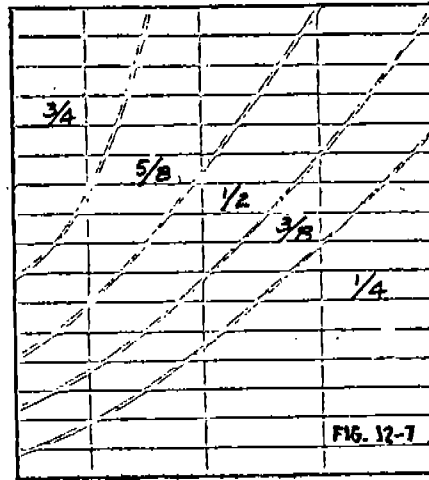
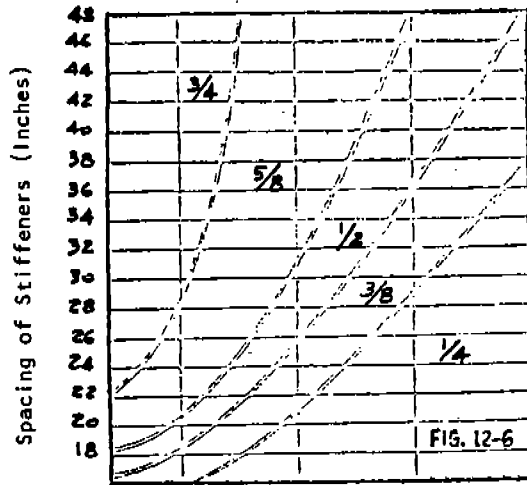

PERMISSIBLE UNFAIRNESS IN STEEL WELDED STRUCTURES

NOTES:

- 1) The tolerances specified above are plus or minus dimensions from a fair line.
- 2) Figures 12-7 and 12-9 apply as follows:
 - a) entire shell
 - b) uppermost strength deck
 - c) longitudinal strength structure within midships 3/5 length including inner bottom tank top continuous decks below the uppermost strength deck
 - d) bulwarks and interior superstructure BHDS.
- 3) For other structural BHDS and decks the unfairness as shown by FIG. 12-6 or 12-8 may be increased by 1/8".
- 4) For internal thickness greater than 1" use the tolerances for 1" material.
- 5) FIGS. 12-6 and 12-8 apply as follows:
 - a) structural ends forming living space boundary and passageways contiguous to such spaces
 - b) decks in way of living spaces
 - c) decks exposed to the weather
 - d) tank and main transverse BHDS
 - e) inner bottom plate longitudinals.

MSP 909-002

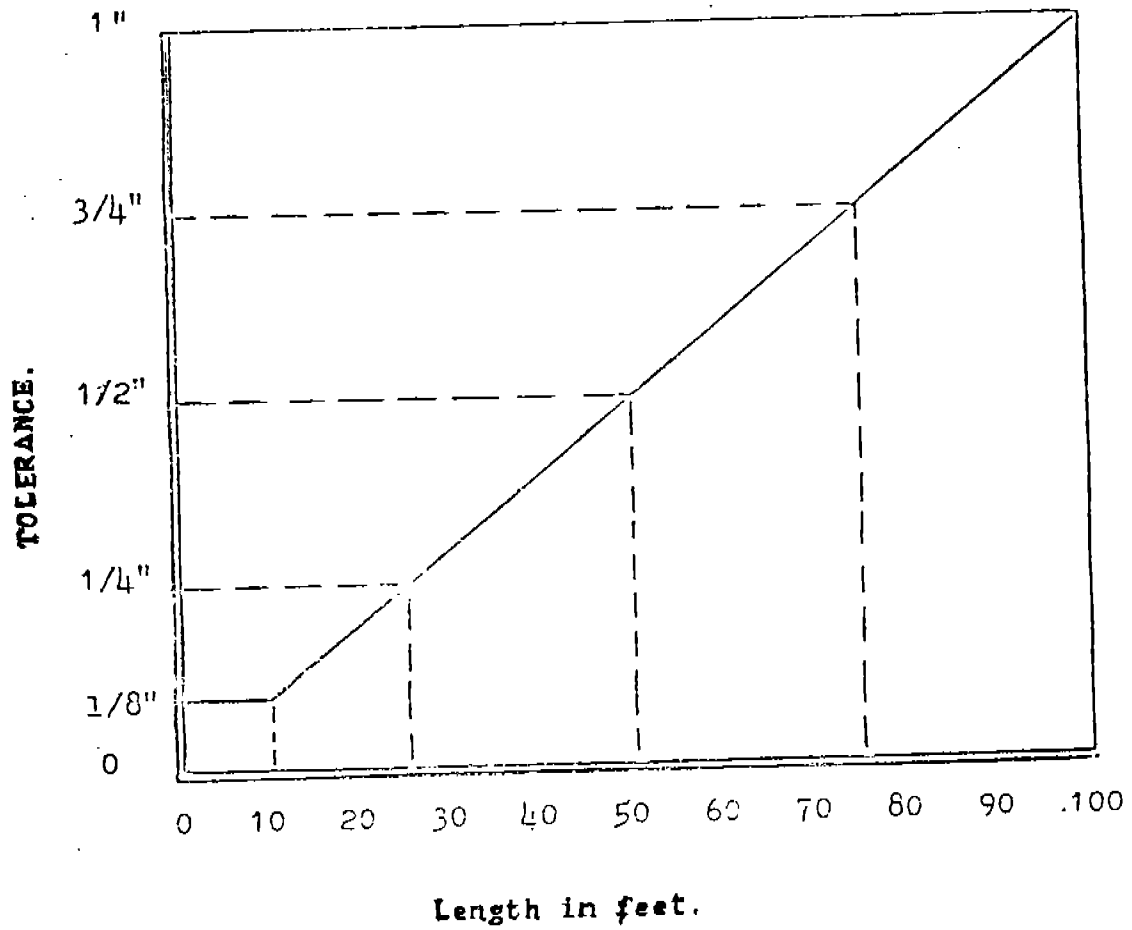

PERMISSIBLE DIMENSIONAL
TOLERANCE
(Plus or Minus)

APPENDIX 9.2.3: SPECIAL TOLERANCES IN USE AT LEVINGSTON SHIPBUILDING FOR A DRILLING RIG

WELDING NOTES

Maximum gap for fillet weld = 3/16". Gaps > 1/16" shall have the fillet weld size increased by an amount equal to the size of the gap.

Permanent backing bars shall be used only where shown on the drawings or specifically approved by the Owner's representative. They shall be of steel equal in grade to the material being welded. Splices in backing bars shall be welded with full penetration welds.

Temporary backing bars shall be removed and the weld root gouged to sound metal before finishing welding.

All faying surfaces shall be seal welded and all welds shall be continuous except as noted. Seal welds shall be a minimum size of V8" and large enough for fusion to the plates joined without cracking.

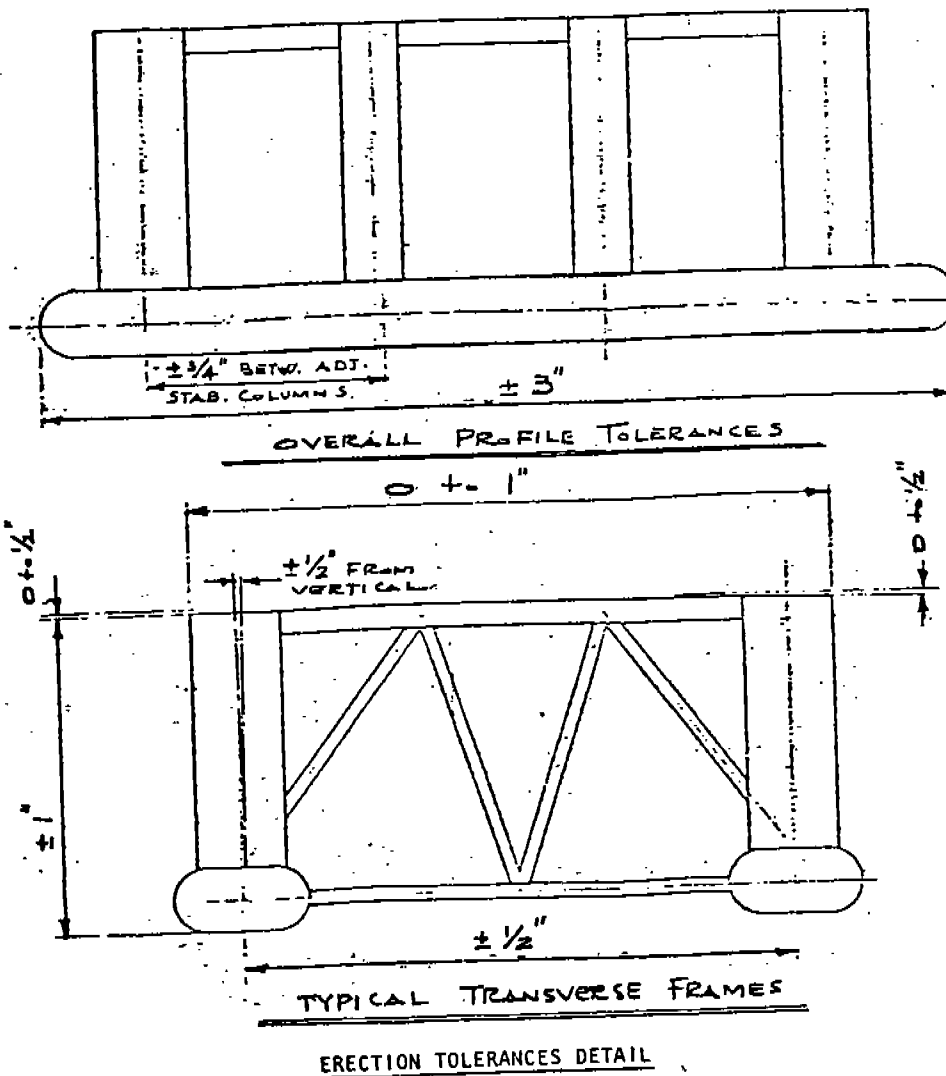

TUE
D
72
72
51
40

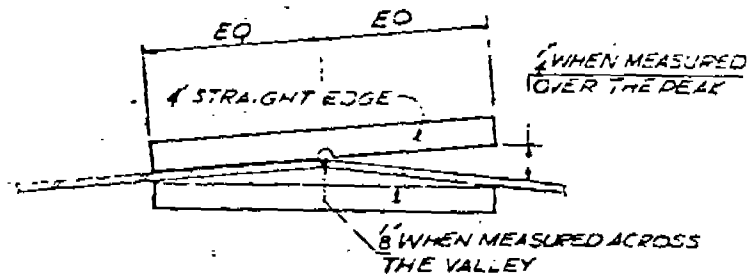

ALLOWABLE WARP IN PLATING BUTTS

USE VALUE SHOWN FOR
 COLUMN CIRCUMFERENTIAL SEAMS,
 HULL PLATING, DECKS & HOUSE TOPS,
 WATER TIGHT FLATS, BEAM AND
 GIRDER WEBS AND INTERIOR BULKHEADS.

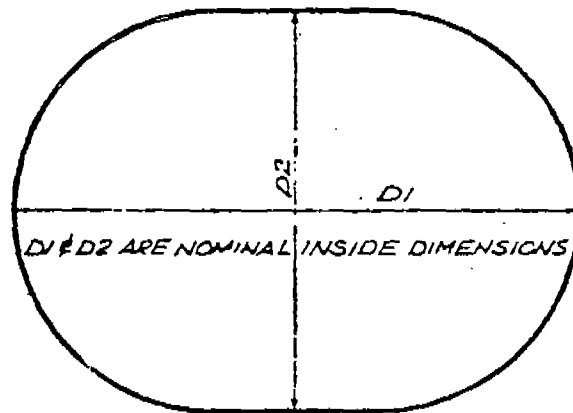
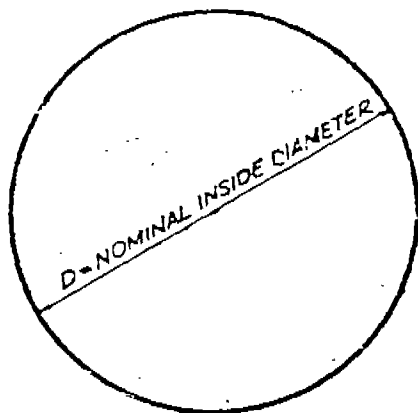

TUBULARS & STABILITY COLUMNS

LOWER HULLS

D, D1 OR D2	MAX VARIATION % OF D, D1 OR D2
TUBULARS TO 36"	± 1%
TUBULARS TO 36" TO 84"	± 0.5% / 1/2" MAX.
STABILITY COLUMNS	± 7/8" (SEE NOTE)
LOWER HULL	D1 = ± 1" - D2 = ± 3/4" (SEE NOTE)

NOTE:

AT STABILITY COLUMNS & LOWER HULL TRANSVERSE BEAMS, THE CIRCUMFERENTIAL LENGTH OF ONE SECTION SHALL BE WITHIN 1/2" OF THE ADJACENT LENGTH.

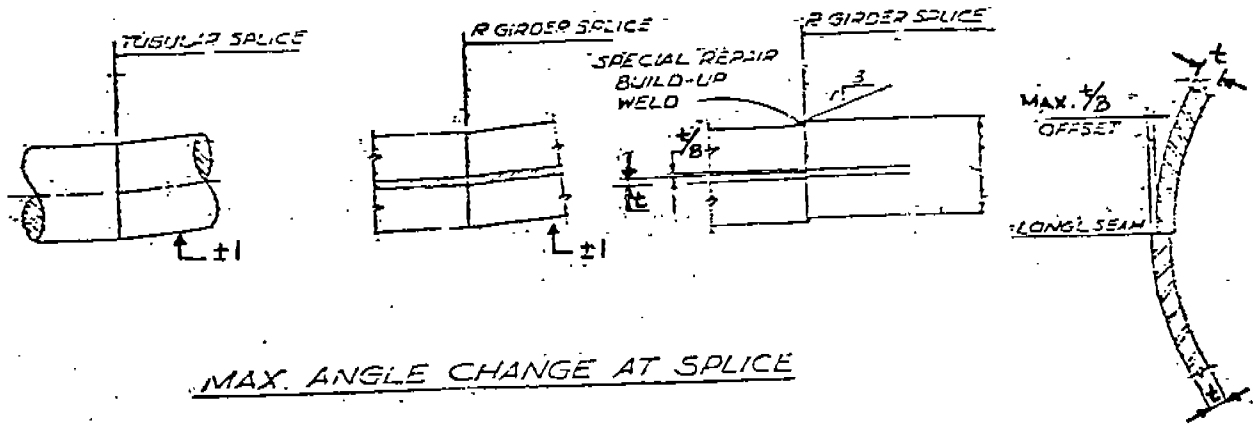

MAX. ANGLE CHANGE AT SPlice

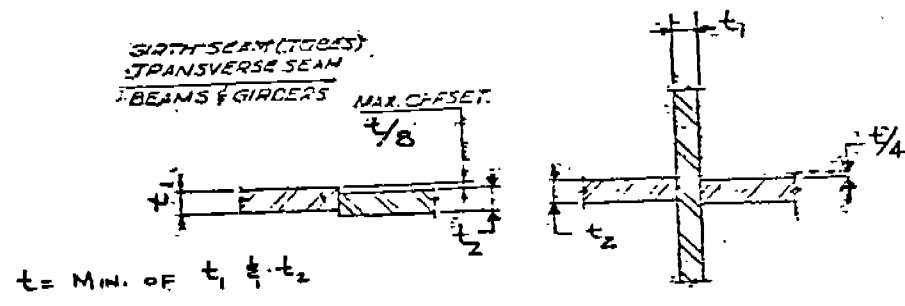

JOINT ALIGNMENT TOLERANCES - DETAIL

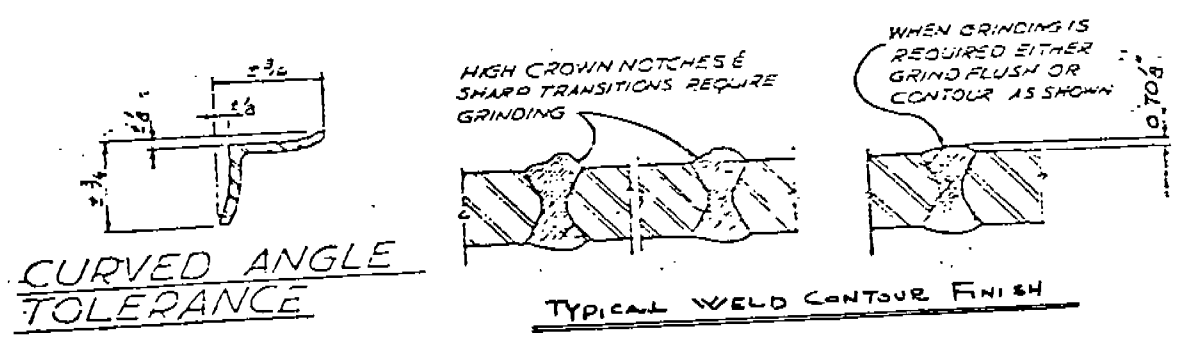

NEWPORT NEWS SB & DD
 DIMENSIONAL TOLERANCES
 FOR LNG TANKERS

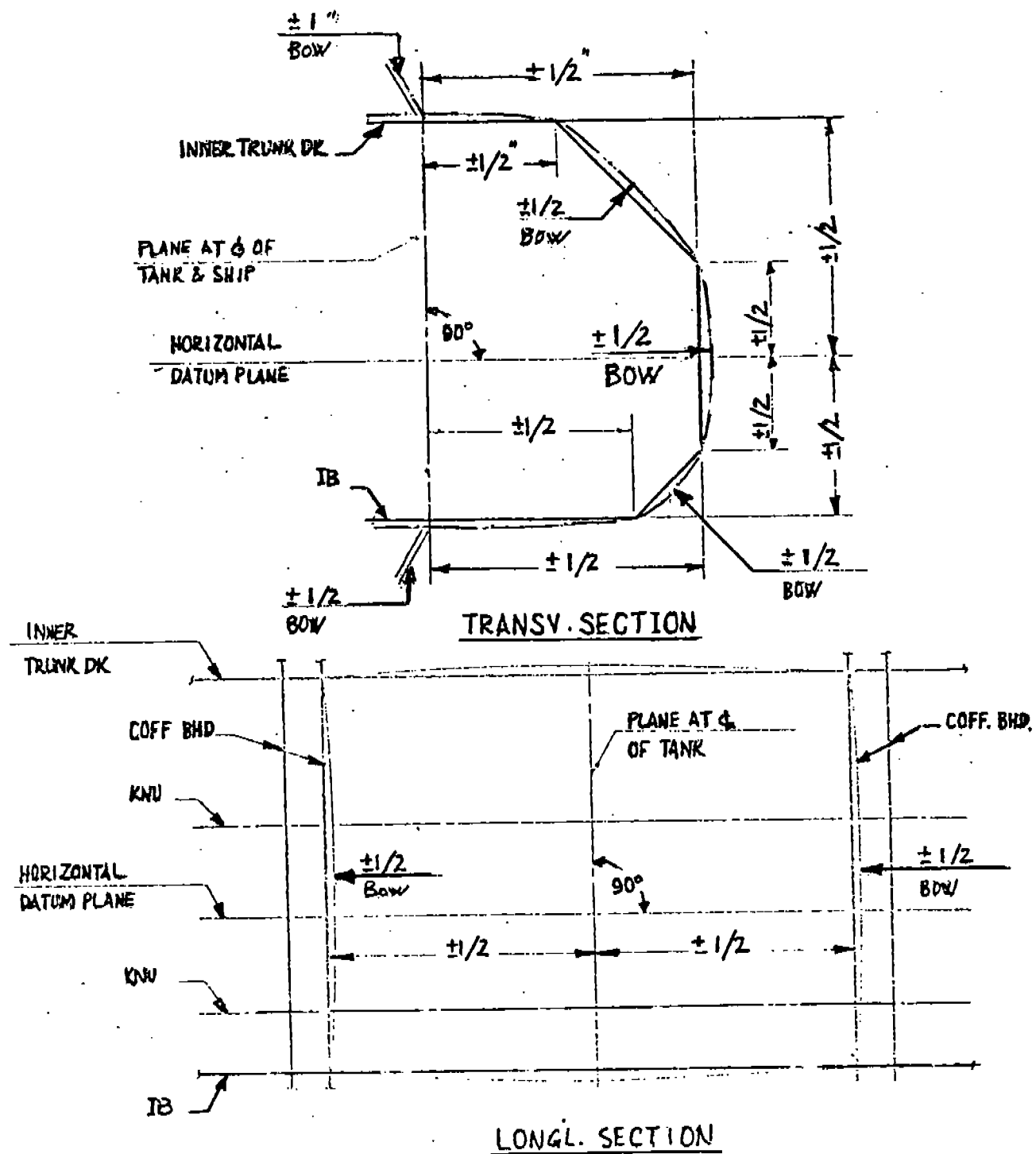

APPENDIX: 9.2.5
SEATRAN SHIPBUILDING
STRUCTURAL TOLERANCES

QUALITY CONTROL INSTRUCTION - FAIRNESS

Appendix (A) is to be used to determine acceptable fairness within welded structure. Areas of applicability are as follows:

- 1) Entire Shell
- 2) Uppermost strength deck
- 3) Bulwarks and exterior superstructure bulkheads
- 4) Tank and main transverse bulkheads
- 5) For other structure bulkheads and decks, the unfairness as permitted by Appendix (A) as applicable, may be increased by 1/8 inch.

METHOD OF INSPECTION - FAIRNESS CHECK

Departure from a plane surface on flat plating or geometric form of curved plating shall not be greater than specified in Appendix (A) by measuring with a straight batten on straight plating and a curved batten on curved plating.

The above noted method is to be used if aid is necessary in determining the acceptability of structure.

DIMENSIONAL TOLERANCES

MAT'L TK	STIFFNER SPACING	TOLERANCE
0" TO 3/8"	0" To 16"	3/8"
	17" To 20"	7/16"
	21" To 36"	5/8"
	37" To 48"	3/4"
	49" To 72"	1"
7/16" To 5/8"	Over 72"	1 1/2"
	0" To 16"	5/16"
	17" To 22"	3/8"
	23" To 26"	9/16"
	27" To 36"	11/16"
11/16" To 1"	37" To 48"	7/8"
	49" To 72"	1"
	Over 72"	1 1/2"
	0" To 24"	1/4"
	25" To 32"	3/8"
1 1/16" To 1 1/2"	33" To 42"	1/2"
	43" To 48"	11/16"
	49" To 72"	13/16"
	Over 72"	1"
	0" To 36"	1/4"
1 1/16" To 1 1/2"	37" To 46"	3/8"
	47" To 60"	7/16"
	61" To 72"	1/2"
	Over 72"	5/8"

APPENDIX: 9.2.6



SUN SHIPBUILDING AND DRYDOCK COMPANY

SHIPBUILDING PRODUCTION STANDARD

(HULL DIVISION)

1976

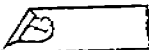
Division		MATERIAL	Unit: inches
Section	Sub-section	Item	Remarks
Surface Flaw	PIT	<p><u>Grade of Pit</u></p> <p>*Note: This indicates the area on the graph and not steel quality.</p>	<p>1. Grade A is to be considered so slight that any repair is unnecessary. Grade B contains a medium degree of pitting and is to be repaired if necessary. Grade C contains an extreme degree of pitting and requires some repair.</p> <p>2. Boundary lines of grade B are included in grade A or C respectively.</p> <p>3. The area ratio of pit denoted r on the horizontal axis, means the percentage of pitted areas where surface appearance is unsatisfactory for practical use. For skin plate</p> $\text{Percentage of pitted area} = \frac{\text{Area of pit}}{\text{Total area of a plate}}$ <p>4. Repair method of surface flaw Depth of defects = d Plate of thickness = t $d < 0.07t$ removed by grinding (but in no case $d \leq 1/8$) $0.07t \leq d \leq 0.2t$ grinding followed by welding.</p>
	Flaking	<p><u>Grade of surface flaking</u></p>	<p>1. Grade A is to be considered so slight that any repair is unnecessary. Grade B contains a medium degree of surface flaking and is to be repaired if necessary. Grade C contains an extreme degree of surface flaking and requires some repair.</p> <p>2. Boundary lines of grade B are included in grade A or C respectively.</p> <p>3. Repair method of surface flaw Depth of defects = d Plate thickness = t $d < 0.07t$ removed by grinding (but in no case $d \leq 1/8$) $0.07t \leq d \leq 0.2t$ grinding followed by welding.</p>



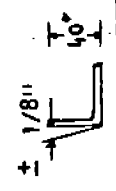

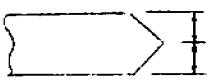

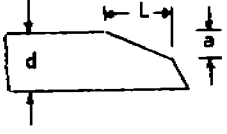
Division		MATERIAL		Unit: Inches
Section	Subsection	Item	Remarks	
Casting Steel	Defects in Casting Steel	In case where defect is over 20% of thickness, or over 1 inch of depth and 6 inches of length.	In the case where cavity cracks and other injurious defects are found, after removing the defects, it is to be checked by magnetic inspection, or ultrasonic inspection, and to be repaired by approved welding procedure.	
Lamination	Local Lamination	(a) 	In the case where the range of lamination is limited, it can be gouged out and built-up by welding as shown in (a).	
		(b) 	In the case where the range of lamination is limited, but is near the plate surface, it is preferable to make the built-up welding as shown in (b).	
	Severe lamination requiring a local exchange of plate		<p>It is recommended to locally exchange the plate, in the case where the range of lamination is fairly extensive. The standard minimum breadth of plate to be exchanged:</p> <p>Shell and strength deck under</p> <p>large constraint 60"</p> <p>not under large constraint 36"</p> <p>Other structural members 12"</p> <p>The whole plate must be exchanged in cases where the degree of lamination is very severe and wide in its extent.</p> <p>The direction of rolling for the replacement plate must be the same as the original. Butts are to be 6" clear of framing.</p>	

Division		MARKING				Unit: Inches
Section	Subsection	Item	Standard Range	Tolerance limits	Remarks	
Cutting line and fitting line compared with correct ones	General members	Size and shape compared with correct ones.	0"	± 1/8"		
		Corner angle. Compared with correct ones.	0"	± 1/8" 40°		
		Curvature	0"	± 1/8"		
		Location of member and mark for fitting compared with correct one.				Reloft to correct position.
		Block marking (panel block). Compared with correct one.				Reloft to correct position.
		Location of member for fitting to block compared with correct one.				Reloft to correct position.

Division		GAS CUTTING			Unit: Inches	
Section	Subsection	Item		Standard range	Tolerance limits	Remarks
Notch	Free Edge	1) Upper edge of sheer strake. 2) Strength deck between (3/5)L & and free edge of opening of shell plate. 3) Main longitudinal strength member.		0"	1/16"	Machine cut 90° and grind edge smooth to eliminate notches.
		Longitudinal and transverse strength members		0	1/16	
	Welded Groove	Butt Weld	Shell plate & upper deck between (3/5)L &	0	1/16	Grind and weld notches if present. (notch in edge preparation)
		Others				
		Fillet weld		0	1/8 max.	
Dimension	Straightness of plate edge	Automatic welding		0	± 1/32	No root opening allowed.
		Manual welding) Semi-automatic welding)		± 3/16	1/8 ± 1/16	
	Depth of Groove			± 1/16	± 1/8	

Division		GAS CUTTING			Unit: Inches
Section	Subsection	Item	Standard range	Tolerance limits	Remarks
Dimension	Angle of Taper		$L=3a$ 60°		Length of taper Angle of taper not to be less than 60° in any case. (See ABS requirement, Rules for Building & Classing Steel Vessels, 1975, Section 30.3.1, and letter of 4 August, 1975, by B. Alia, principal surveyor of A.B.S.)
	Size of Member	General members compared with correct sizes Especially for the depth of floor and girder of double bottom compared with correct sizes. Breadth of face bar, compared with correct size.	$\pm 1/16$ $\pm 1/16$ $\pm 1/16$	$\pm 1/8$ $\pm 1/8$ $- 1/8$ to $+ 3/16$	

Division		GAS CUTTING			Unit: Inches
Section	Subsection	Item	Standard range	Tolerance limits	Remarks
Dimension	Edge Preparation	Automatic welding		Bevel Angle No bevel 15° 10°	Plate thickness range 0 < t ≤ 5/8" 5/8 < t ≤ 1 1/4" t > 1 1/4"
		Semi-automatic welding		22½°	t > 1 1/4"
		Manual welding		30°	
		Fab welding (one-sided welding)		20° bevel	See Sun standard Dwg. (SS-704)
		Consumable Nozzle (Electric Slag)	3/4" No bevel	3/4 to 7/8 root No bevel	

Division		FABRICATION			Unit: Inches
Section	Subsection	Item	Standard range	Tolerance limit	Remarks
Flange longitudinal	Breadth of Flange	 Compared with correct size	$\pm 1/8$	$\pm 1/4$	Mill allowance
		 Compared with correct size	$\pm 1/8$	$\pm 1/4$	Mill allowance
	Angle between Flange & Web	 Compared with template	$\pm 1/8$ <u>4"</u>	$\pm 1/4$ <u>4"</u>	Per 4" breadth
	Curvature or straightness in the plane of the flange	 Per 400 inches in length	$\pm 3/8$	± 1	Standard mill allowance
	Curvature or straightness in the plane of the web	 Per 400 inches in length	$\pm 3/8$	± 1	Standard mill allowance
Flange bracket	Breadth of flange	 compared with correct size	$\pm 1/8$	$\pm 1/4$	
	Angle between flange and web	 compared with template per 4 inch breadth of flange	$\pm 1/8$ " <u>4"</u>	$\pm 1/4$ " <u>4"</u>	Same as for longitudinal

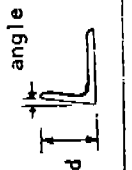
Division		FABRICATION			Unit: Inches
Section	Subsection	Item	Standard range	Tolerance limit	Remarks
Template for bending (plane or box shape)	Template in box shape	Location of plate edge, compared with correct one	$\pm 1/16$	$\pm 1/8$	
		Shape of curved surface, compared with correct one	$\pm 1/16$	$\pm 1/8$	
	Section template	Location of check line for levelling by sight, compared with correct one. (for transverse)	$\pm 1/8$	$\pm 1/4$	Use of roll sets or furnace sets.
Angle & Built up Plates	Other templates	(for longitudinal)	$\pm 1/8$	$\pm 1/4$	Straight line method using cold frame bending machine.
		Shape, compared with correct one	$\pm 1/16$	$\pm 1/8$	Per 20'-0" length
		Shape, compared with correct one.	$\pm 1/16$	$\pm 1/8$	
Stringer angle	Stringer angle	angle compared with angle gauge	$\pm \frac{1/16}{D}$	$\pm \frac{1/8}{D}$	Mill tolerance
		 angle compared with template	$\pm \frac{1/8}{40^\circ}$	$\pm \frac{1/4}{40^\circ}$	

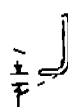
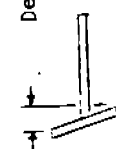
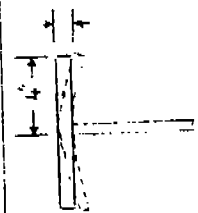
Division		FABRICATION				Unit: Inches
Section	Subsection	Item	Standard range	Tolerance limit	Remarks	
Angles and built-up plates	Frame and Longitudinals	Curvature compared with template or check line		1"	Per 35' -0" length	
		Deviation from correct form		$\pm 1/8$	$\pm 1/4$	Opening of fit up to formed section.
		Deviation in flange angle		$\pm 1/8$	$\pm 1/4$	
		Deviation of face plate		$\pm 1/8$	$\pm 1/4$	As the result of weld distortion per 4" length
				$\pm 1/8$	$\pm 1/4$	Per 4" length

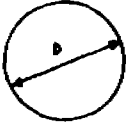
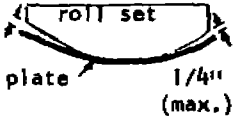

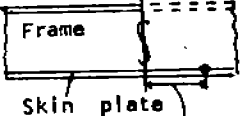

Division		FABRICATION			Unit: Inches
Section	Subsection	Item	Standard range	Tolerance limit	Remarks
Plates	Cylindrical Structures (mast, post, etc.)	 Diameters	$\pm \frac{D}{200}$ But $\pm 5/32$ (max.)	$\pm \frac{D}{150}$ But $\pm 1/4$ (max.)	Depends on diameter
	Curved shell plate	In regard to check line (for longitudinal)	$\pm 1/4$	$\pm 1/2$	Per 30'-0" length
		" (for transverse)		$\pm 1/4$	Open to template only
	Gap between shell plate and section template			$1/4$ (max.)	Not permitted, must either fit set or open at sides to $1/4$ Inch max. 

Division		SUB-ASSEMBLY			Unit: Inches
Section	Subsection	Item	Standard range	Tolerance limits	Remarks
Accuracy of Dimension	Flat plate sub assembly	Breadth of subassembly	$\pm 1/4"$	$\pm 5/16"$	Depends on size (40' x 60' typical) cut when too long.
		Length of sub assembly	$\pm 1/4$	$\pm 5/16$	Cut when too long
		Squareness of sub-assembly		$\pm 1/4$	Measured difference of diagonal length at final marking lines
		Distortion of sub assembly		$\pm 1/4$	Measured on the face of web beam or girder. Depends on length.
		Deviation of interior members from skin plating.	$\pm 1/16$	$\pm 1/4'$	Excluding the case when interior members are connected by overlapped joint.  Accuracy of this dimension
	Curved Plate Sub-Assembly	Breadth of sub assembly	$\pm 3/16$	$\pm 5/16$	Measured along the girth cut when too long.
		Length of sub assembly	$\pm 3/16$	$\pm 5/16$	Cut when too long

Section		SUB - ASSEMBLY			Unit: Inches		
Division	Subsection	Item	Standard range	Tolerance limits	Remarks		
Accuracy of Dimension	Curved Plate Sub-Assembly	Distortion of sub assembly	3/8"	3/4"	Measured on face of web or girder. Correct the final marking line when the distortion exceeds the limits.		
		Squareness of sub assembly.	3/8	9/16	Measured difference of diagonal length at final marking lines.		
		Deviation of interior members from skin plating		1/4	The same as for the flat assembly.		
		Breadth of each panel			The same as for the flat plate sub-assembly.		
		Length of each panel			Same as above.		
	Plate block sub - assembly		Distortion of each panel			Same as above.	
			Deviation of interior members from skin plating			Same as above.	

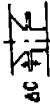

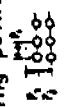
Division		ACCURACY OF HULL FORM			Unit: Inches
Section	Subsection	Item	Standard range	Tolerance limit	Remarks
Principal Dimensions	Length	Length between perpendiculars	$\pm 1/2''$ per 330 ft.	$\pm 1''$ per 330 feet	Applied to ships of 330 ft. length and above. For the convenience of the measurement the point where the keel is connected to the curve of the stern may be substituted for the fore perpendicular in the measurement of the length.
		Length between aft perpendicular and fwd. bulkhead of engine room	$\pm 1/2$	$\pm 1 1/2$	Shaft length. (Stock allowed on shaft flanges.)
	Breadth	Molded breadth amidships	$\pm 1/4$	$\pm 1/2$	Applied to ships of 49 ft. breadth and above. Measured on the main or weather deck.
	Depth	Molded depth amidships	$\pm 1/8$	$\pm 1/2$	Applied to ships of 33 ft. depth and above.
Deformation of Hull Form	Flatness of Keel	Deformation for the whole length	$\pm 1/2$	- 1' to + 3/4	Ups (-) and downs (+) against the check line of keel sighting. Per 600' length.
		Deformation for the distance between two adjacent bhds.	$\pm 1/8$	$\pm 3/8$	Sighting by the transit, laser beam, or water level.



Division		RIVETING			Unit: Inches
Section	Subsection	Item	Standard range	Tolerance limits	Remarks
Rivet	Hole	Diameter compared with correct size.			Relation between rivet dia (d) and hole dia (φ)
		Δφ = Difference from standard (φ)		$d \leq 5/8$ $-1/64 \leq \Delta \phi \leq 1/16$ $3/4 \leq d \leq 1/8$ $-1/32 \leq \Delta \phi \leq 1/16$ $d \geq 1/4$ $-1/16 \leq \Delta \phi \leq 1/16$	$\phi = d + 1/16$ $\phi = d + 1/16$ $\phi = d + 1/16$
Rivet	Counter sunk	Depth compared with correct size.			
		ΔH = Difference from standard (H)		$-1/32 \leq \Delta H \leq 1/16$	

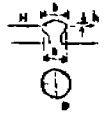

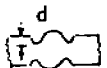
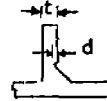
Division		RIVETING			Unit: Inches
Section	Subsection	Item	Standard range	Tolerance limits	Remarks
	Counter-sunk	Inclination $\Delta H' = H_1 - H_2$ 	$\Delta H' \leq 1/16$	$\Delta H' \leq 1/16$	
	Faying Surface contact	Clearance ΔC 	$\Delta C \leq 1/64$	$\Delta C \leq 1/64$	Test knife tight at caulking edge, feeler gauge not permitted to reach rivet hole on opposite side.
	Unfairness Through holes	Discrepancy 	$\Delta G \leq 1/32$	$\Delta G \leq 1/16$	$\Delta G > 1/16$ -To be reamed $\Delta G \geq 1/8$ -To be re-drilled after building up by weld.
	Pitch	Deviation from marking point 	$\Delta P_1 = P_2 = P_3$ $\Delta P = \pm 1/16$	$P = \pm 1/8$	
	Counter-sunk head	Edge height = h 	$0 \leq h \leq 1/8$	$0 \leq h \leq 7/16$	

Rivet Hole

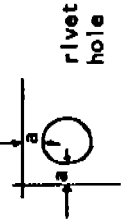
Division		RIVETING			Unit: Inches		
Section	Subsection	Item	Standard range	Tolerance limits	Remarks		
Rivet hole	Point	Deformation $\delta = D_1 - D_2$	$d \leq 3/4$ $d \geq 7/8$	$\delta \leq 1/16$ $\delta \leq 1/8$	$d \leq 3/4$ $d \geq 7/8$	$\delta \leq 1/8$ $\delta \leq 3/16$	
		Overlap $\Delta D = D - D'$	$d \leq 3/4$ $d \geq 7/8$	$\Delta D \leq 1/4$ $\Delta D \leq 5/16$	$d \leq 3/4$ $d \geq 7/8$	$\Delta D \leq 5/16$ $\Delta D \leq 3/8$	
		Point height = H	$d \leq 5/8$ $d = 3/4, 7/8$	$1/16 \leq H \leq 1/8$ $1/8 \leq H \leq 3/16$	$d \leq 5/8$ $d = 3/4, 7/8$	$1/16 \leq H \leq 3/16$ $1/8 \leq H \leq 1/4$	
		Edge height = h	$d \geq 1$ $d \leq 3/4$ $d \geq 7/8$	$1/8 \leq H \leq 1/4$ $h \leq 1/8$ $h \leq 1/8$	$d \geq 1$ $d \leq 3/4$ $d \geq 7/8$	$1/8 \leq H \leq 1/4$ $h \leq 1/8$ $h \leq 1/8$	
							

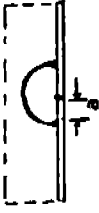
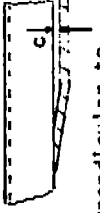
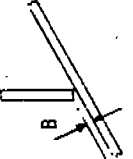

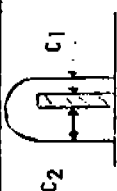
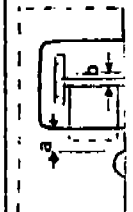
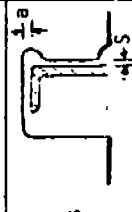
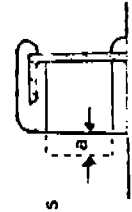
Division		WELDING		Unit: Inches
Section	Subsection	Item	Tolerance limits	Remarks
Shape of bead	Undercut (butt weld)	Skin plate and face plate between $(3/5)L$ 	$d \leq 1/32$ no repair necessary. $1/32 < d \leq 1/16$ repair where found In continuous lengths greater than 4". $d > 1/16$ repair where found	To be repaired by using small electrode.
	Undercut (fillet weld)		$d \leq 1/16$ for "t" greater than or equal to $1/2$ ". $d \leq 1/32$ for "t" less than $1/2$ ".	Repair when defect exceeds tolerance limits.
	Leg Length	Compared with correct ones (L, t)	L: leg length t: throat length 	No allowance, gauge to size and repair if under, in continuous length.
Distortion of Welding Joint	Angular distortion of welding joint	Skin plate between $(3/5) L \&$	 Span of frame or beam $W \leq 1/4$	In cases where it is over tolerance limits, it is to be repaired by line heating or to be re-welded after cutting & refitting.
		Fore and aft shell plating and transverse strength member.	$W \leq 5/16$	
		Others	$W \leq 5/16$	

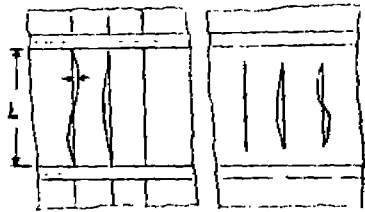
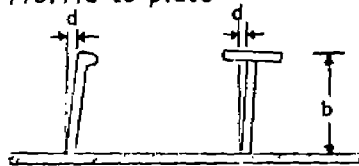
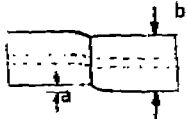

Division		ALIGNMENT AND FINISHING		Unit: Inches
Section	Subsection	Item	Tolerance limit	Remarks
Minimum distance of weld to adjacent weld or rivet hole	Butt weld to Butt weld		$a \geq 2''$	No set limit, ABS rule.
	Butt weld to Fillet weld		$a \geq 2''$	Same as above.
			$a \geq 3/4''$ Rat hole is not to be cut if "a" is at least 3/4" from edge of butt weld to edge of fillet weld.	In special cases even smaller distances can be acceptable.
Gap between members	Gap between plate and stiffening member	Stiffening member location (without edge preparation)  Perpendicular to plate	$c \leq 3/16$	
		 Oblique to plate	B (not limited)	No edge preparation on 1/2" plate or below. (natural opening)

Division		ALIGNMENT AND FINISHING		Unit: Inches
Section	Subsection	Item	Tolerance Limit	Remarks
Gap between members	Through piece and tight plate	 <p>C_1 C_2</p>	$C_2 \leq 1/2$	
		 <p>a b</p>	$b = 1/2$ max. $a = 3$	Maximum off center
		 <p>t - web thickness a S</p>	$S = 3/16$ max.	$a = \text{max. } 1/4''$ if over $1/4''$, install "Tee" liner
		 <p>t - web thickness a</p>	$a = 2''$ $a = 2t + 1$	Applied to clips and collars only. Standard for effective lapped joint. See A.S.S. rule 30.9.3 "Rules for Building & Classing Steel Vessels 1975"
		 <p>a b</p>	$b = 2''$	Same as above.

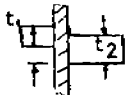
Division		ALIGNMENT AND FINISHING		Unit: Inches
Section	Subsection	Item	Tolerance limit	Remarks
Fitting Accuracy	Permissible distortion of beams, frames girders and stiffeners	Deviation from the straight line in reference to the length between 2 points of support. 	$d \leq 5/16''$ $d \leq 1/4 + \frac{L}{500}$ $d \leq 1/2$	For length of up to 30 inches. For lengths of up to 125 inches. For lengths over 125 inches.
	Permissible warping	Profile to plate 	with profiles of $b = 8''$ $b = 20''$ $b = 40''$	Max. deviation $d \leq 3/8''$ $d \leq 3/4''$ $d \leq 1''$ Intermediate values must be interpolated.
	Flange in T longitudinals	Line up error 	$a < 5/16$, but with a maximum of $.04b$	Refit if a exceeds $.04b$.

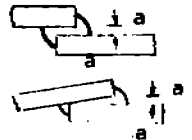
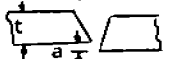

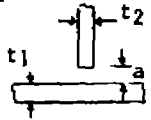
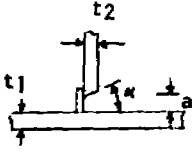
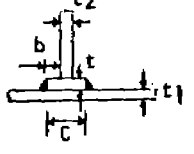
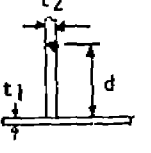

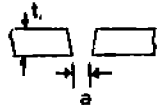

9-47

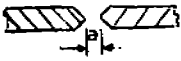
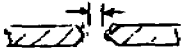
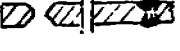
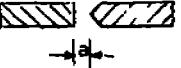
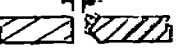
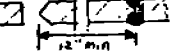
Division		ALIGNMENT AND FINISHING			Unit: Inches
Section	Subsection	Item	Standard range	Tolerance limit	Remarks
Fitting Accuracy.	Alignment of fillet joint 	Strength member		$a \leq \frac{t_1}{2}$	Maximum offset to be 1/2 of t_1 , but in no case more than the fillet weld size.
	a =difference $t_1 \leq t_2$	Other		$a \leq \frac{t_1}{2}$	Maximum offset
	Differences between the beam & frame 	Beam a: difference Beamknee Frame	$\frac{3}{16}$ "	$a \leq \frac{t}{2}$	1/2 web or beam thickness
	Lapp weld 		$a \leq \frac{1}{16}$	$a \leq \frac{1}{8}$	1) $\frac{1}{8} \leq a \leq \frac{3}{16}$ Increase weld leg length, rule leg $\geq a$ 2) $a > \frac{3}{16}$ refit
	Alignment of butt joint 	Strength member	0	$a \leq \frac{1}{8}$	$a \leq \frac{1}{8}$ Refit
a =difference t =thickness (thinner plate)	Other		$a \leq .2t$ max. 1/8	$a > .2t$ or $a > 1/8$ Refit	

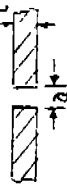
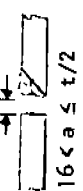
Division		ALIGNMENT AND FINISHING			Unit: Inches
Section	Subsection	Item	Standard range	Tolerance limit	Remarks
Fitting Accuracy	Gap before welding (fillet weld)	Fillet weld 		$0 \leq a \leq 1/4$	
				$a \leq \frac{t_1}{2}$	Welding with bevel preparation to make bevel edge of web to 30-45°, attach a backing strip and remove after welding, then weld the opposite side. Weld size to increase by "a".
				$b \leq 1/8$ $c \geq 2.5 \times t$	Use when opening exceeds 1/4". "T" piece to extend 1/8 beyond weld, t not less than t2 but not more than 2t2. $t_2 \leq t \leq 2t_2$
				$d \geq 6$	Partial renew. Use when t (thickness of liner) exceeds 4 (t2).
					Build up with weld to reduce separation gap.

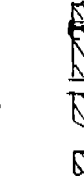
Division		ALIGNMENT AND FINISHING			Unit: inches
Section	Subsection	Item	Standard range	Tolerance limit	Remarks
Fitting Accuracy	Gap before welding	Butt weld (manual welding) a: Gap  Standard gap opening. $a=3/16$	Gap opening $a=3/16 \pm 1/16$	$a < t$	1) After welding with backing strip, remove it and finish weld after back chipping. 2) $1/4 < a \leq t$ Add weld to edge to produce required gap of 3/16. 3) $a < 1/8$ Trim edge and re-bevel to $a=3/16$ 4) $a > t$, Partial plate renew.
	Gap before welding	Butt weld (automatic welding) a: minimum separation gap between plates 1) Both sides submerged arc welding	$0 \leq a \leq 1/16$	$0 \leq a \leq 3/16$	In the case where burnthrough may occur, use a sealing bead.
		2) Flux core welding with manual or CO ₂ welding	$0 \leq a \leq 1/8$	$0 \leq a \leq 3/16$	In case where a is over 3/16, see welding manual
	Gap before welding	3) One sided submerged arc welding with flux copper backing or flux backing. 4) One sided submerged arc welding with fiber asbestos backing.	$0 \leq a \leq 1/16$	$0 \leq a \leq 1/8$	In the case where burnthrough may occur use a sealing bead.
			$0 \leq a \leq 1/4$	$0 \leq a \leq 5/16$	Same as above.

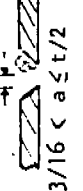
Division		ALIGNMENT AND FINISHING		Unit: Inches
Section	Subsection	Item	Tolerance limits	Remarks
Edge Preparation	X-bevel		$a \leq 3/16$	<p>1)  $3/16 < a \leq t + 3/16$ Build up with weld, max. 1/2t on each plate. A.B.S. Inspector to be notified.</p> <p>2)  $a > t + 3/16$ Renew plate section.</p>
	K-bevel		$a \leq 3/16$	<p>1)  $3/16 < a \leq t + 3/16$ Build up with weld max. 1/2t on each plate. A.B.S. Inspector to be notified.</p> <p> $a > t + 3/16$ Renew plate section</p>

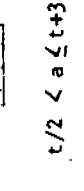

Division		ALIGNMENT AND FINISHING		Unit: Inches
Section	Subsection	Item	Tolerance limits	Remarks
Edge Preparation	1-bevel	 <p>Used for submerged arc welding only, maximum plate thickness t used with this preparation, $t \leq 5/8"$</p>	$a \leq 3/16$	<p>1)  Bevel 45°, build up with weld on one side. A.B.S. inspector to be notified.</p> <p>2)  Use backing up strip.</p> <p>3)  Renew plate section.</p> <p>$t/2 < a \leq t+3/16$</p> <p>$a > t+3/16$</p>
	V-bevel	 <p>$a=3/16"$ (standard opening)</p>	$a \leq 3/16$	<p>1)  Build up with weld on one side. A.B.S. inspector to be notified.</p> <p>2)  Use backing strip.</p> <p>3)  Renew plate section.</p> <p>$3/16 < a \leq t/2$</p> <p>$t/2 < a \leq t+3/16$</p> <p>$a > t+3/16$</p>

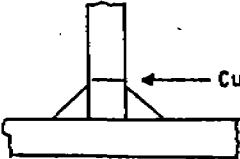
Division		ALIGNMENT AND FINISHING		Unit: Inches
Section	Subsection	Item	Tolerance limit	Remarks
Finishing up the traces of temp- orary pieces	Part to have good appearance	Outside surface of shell plates, exposed decks, exposed super structure	Grind, smooth all external areas	
	Not necessary to have good appearance	Inside of tank, inside of ceiling, deck to be shielded with deck composition, etc.	Grind smooth only areas that could cause harm upon contact by personnel.	
Surface Defect	Part to have good appearance	Same as above	Allowable undercut on the trace of piece Depth $\leq 1/16$ Length - as found	Weld up to make flush by grinding, no chipping allowed.
	Not necessary to have good appearance	Same as above	Correct only particularly conspicuous defect.	Only weld up, not necessary to chip.
Staging clips	Clips to be removed	In tank	Not to be removed	Method of removing 1) Parts ruining appear- ance and passages to be flushed to base plate. 2) Others to be done by gas cutting at the top of the fillet weld. (cont'd)
		In engine room	Parts ruining appearance and passage to be removed.	
		In hold	Underside of hold and hatch coaming, Not to be removed.	
		Exposed parts of shell, upper deck, etc.	To be removed and ground.	

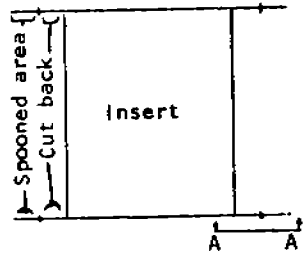
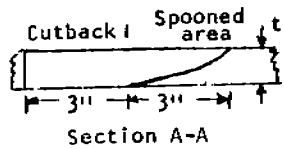
Division		ALIGNMENT AND FINISHING		Unit: inches
Section	Subsection	Item	Tolerance limit	Remarks
Lifting pad pieces	Lifting pad pieces to be removed	In tank	Not to be removed except for interference.	Remove notches due to manual burning.  But parts especially important for strength to be rounded off.
		In engine room	Remove for interference only.	
		In hold	Remove from decks only.	
		Exposed parts of shell, upper deck, etc.	To be removed, flushed and ground.	
Treatment of holes made erroneously	$D \leq 1\ 1/4"$ D: diameter of hole	Skin plate, any area in the shell, deck, etc.	Countersink hole and weld, then finish with back weld.	
	$1\ 1/4 < D \leq 10"$	Skin plate, any area in the shell, deck, etc.	Install spigot patches per approved method.	See Sun Sketch 59-112 revised 1976.

Division		ALIGNMENT AND FINISHING		Unit: Inches
Section	Subsection	Item	Tolerance limits	Remarks
Treatment of holes made erroneously	Serration, scallops and slots	$D > 10''$	Use of plate insert.	<p>With any openings over, 10 inches install insert, square with cutbacks 3 inches beyond butt, Beveled 30° to $3/16$. Welded and back gouge with final weld. Spooned out area to extend 3 inches beyond cutbacks, from full thickness at cutback to 0'' at end.</p>  

Division		DEFORMATION			Unit: Inches	
Section	Subsection	Item	Standard range	Tolerance Limits	Remarks	
UNFAIRNESS	Shell plate	Parallel part side	1/8	1/4	Typical 30" panels or between frames.	
		Parallel part bottom	1/8	1/4		
		Fore and aft part	1/8	1/4		
		Double bottom tank top plate		1/8	3/8	Plating thickness 20.4#) to) Tank top 25.5#) and Bhd's.
	Bulkhead	Longitudinal bulkhead	1/4	3/8		
		Transverse bulkhead	1/4	3/8		
		Swash bulkhead	1/4	3/8		
	Strength Deck	Parallel part (between (3/5) L & M)	1/8	1/4	28.6#) to) Shell 51#)	
		Fore and aft part	1/8	1/4		
		Covered part	1/8	5/16		
	Second Deck	Bare part	1/8	1/4	5.1#) to) Bulkhead 10.2#) in quarters	
		Covered part	1/4	3/8		
	Forecastle deck Poop deck	Bare part	1/8	1/4		
		Covered part	1/4	3/8		
	Super structure deck	Bare part	1/8	1/4		
		Covered part	1/4	3/8		
	Cross deck			3/16	1/4	
	House Wall	Outside Wall		1/8	3/16	
		Inside Wall		1/4	5/16	
		Covered part		1/4	3/8	

Division		DEFORMATION				Unit: Inches
Section	Subsection	Item	Standard Range	Tolerance Limits	Remarks	
Unfitness	Interior Member	Web of girder, transverse	1/8	1/8		
	Floor and girder of doublebottom		1/8	1/4		20.5# Floors and to) girders 30.6#)
Miscellaneous	Distortion of girder and transverse (at the part of upper edge & flange)	Length of span L 	1/8	1/4		Length of span, 30 feet.
		$L \leq 40$ $40 < L < 138$ $L \geq 138$ 	$\frac{3}{16} + \frac{2L}{1000}$ $\frac{3}{8}$	$\frac{5}{16} + \frac{2L}{1000}$ $\frac{1}{2}$		
	Distortion of H pillar between decks 		3/16	1/4		Typical length 10 feet.

9-57

Division		DEFORMATION			Unit: Inches
Section	Subsection	Item	Standard Range	Tolerance Limit	Remarks
	Distortion of tripping brkt. and small stiffener with web plate	Distortion at the part of free edge 	1/8	1/4	

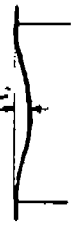
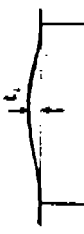
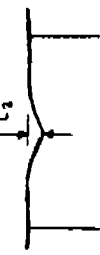
Division		DEFORMATIONS				Unit: Inches	
Section	Subsection	Item	Area	Depth t ₁	Depth t ₂	Remarks	
Dents	Dents in plate panel and unfairness depression of weld seam. (deviations from the straight line.)	Shell	Above water line Below water line	5/16 5/16	3/8 7/16	1) Dents in plate panel 	
		Topside Deck	Free area	1/4	3/8	2) Unfairness of weld depression. 	
		Superstructure Decks	Covered area	3/8			
		Tweendecks		3/8	7/16		
		Superstructure and house bulkheads	Outer bulkhead inner bulkhead visible within accommodation	Outer bulkhead	1/4	1/4	3) Dents larger than t ₁ or t ₂ require referring to within limits. 
				Inner bulkhead outside accommodation	3/8	5/16	
		Superstructure decks & house tops	Free area Covered area	Free area	1/4	1/4	4) Bulkheads covered on both sides and decks insulated on both sides will not be faired.
				Covered area	3/8	3/8	
		Double bottom Bulkheads		Double bottom	5/16	1/2	
				Bulkheads	5/16	3/8	

Division		MISCELLANEOUS			Unit: Inches
Section	Subsection	Item	Standard Range	Tolerance Limit	Remarks
Painting for welded & riveted joint at tightness test or construction inspection.	Sub-assembly and assembly welded joint		Paint after Hull Inspec- tion.		
	Erection welded joint		Paint after tightness test. Butts of skin plates are coated wash primer before final construction inspection. Paint before tightness test, when tanks given special protective coatings are to be hydro- statically tested.	Butts of skin plates are coated after final con- struction inspection and before leak test.	
	Riveted joint	Faying surface before riveting.	Paint after tightness test.		Must be coated ex- cept tanks.
Draft Mark	In regard to the template		$\pm 1/16$	$\pm 1/8$	
Freeboard Mark	In regard to the template		$\pm 1/16$	$\pm 1/8$	
Hatch Coaming	Principal dimensions of hatch coaming	Length	$\pm 3/16$	$\pm 3/8$	
		Breadth	$\pm 3/16$	$\pm 3/8$	
		Difference of diagonal length	$\pm 3/8$	$\pm 9/16$	
	Deformation of horizontal stiffener	End coaming	$\pm 1/8$	$\pm 3/16$	Per 20'-0" length
		Side coaming	$\pm 3/16$	$\pm 5/16$	
		Deformation per 8 feet (random)	$\pm 1/16$	$\pm 3/16$	

Division		MISCELLANEOUS			Unit: Inches	
Section	Subsection	Item	Standard Range	Tolerance limit	Remarks	
Opening of Entrance	Opening of steel door	Breadth and height	+ 3/16	+ 5/16	A.B.S. load line requirement, no negative valves.	
		Sill height	0 ~ 9/16	0 ~ +1 3/16		
		Deformation	$\pm \frac{1/16}{40}$	$\pm \frac{1/8}{40}$		
	Opening of deck (through type)	Opening of deck (through type)	Breadth	$\pm 1/16$	$\pm 1/8$	
			Length	$\pm 1/8$	$\pm 3/16$	
		Opening of deck (not through type)	Breadth	- 1/8 ~ + 1/16	-3/16 ~ + 1/8	
			Length	- 1/8 ~ + 1/16	-3/16 ~ + 1/8	

Division		TIGHTNESS TEST	Unit: Inches
Section	Subsection	Remarks	
Tank Testing	Tightness Test	The classification rules decides whether a pneumatic or hydrostatic test is to be carried out, unless for yard information or pre-test.	
	Functional and Strength Test	Functional and strength tests may be carried out at the end of the building time in accordance with the Classification Society Rules.	
	Preservation	Considering the importance of the proper application of coatings, structural members accepted during pre-assembly can be fully coated. After installation on board, prior to the pneumatic test, the erecting seams can be primed inside, but not fully coated outside. If a hydrostatic tightness test is carried out, all coatings may be applied inside and outside.	
	Correction of defects during and after pressure testing.	<ol style="list-style-type: none"> 1) Pores will be pressure-caulked. Rewelding will be done only if the required weld thickness is insufficient. 2) Small spots will be pressure-caulked and welded after release of pressure. Another pressure test will not be carried out. 3) Larger spots will be corrected by welding after release of pressure. A new pressure test will be carried out. 	
	Retrofits	In the case of locally limited retrofits in tanks already tested, the relative area will be retested by hose-testing, or by soaping and using compressed air from the opposite side (soap bubble test).	
	Closing devices	<ol style="list-style-type: none"> 1) Weather tight steel doors, windows, cargo and access notches will be tested for tightness, by application of a jet of water at a pressure of 35 lb/in.² gauge and at a distance of 60 inches using a nozzle of 1/2 inch in diameter. 2) Hose testing of decks, shell, bulkheads, exposed deckhouse bulkheads, etc. will not be carried out for welded construction. 3) Gas tight, fire-resisting or non-weather-tight doors and hatches will be tested as per ABS and United States Coast Guard requirements. 	

9.2.7 NAVY UNFAIRNESS TOLERANCES

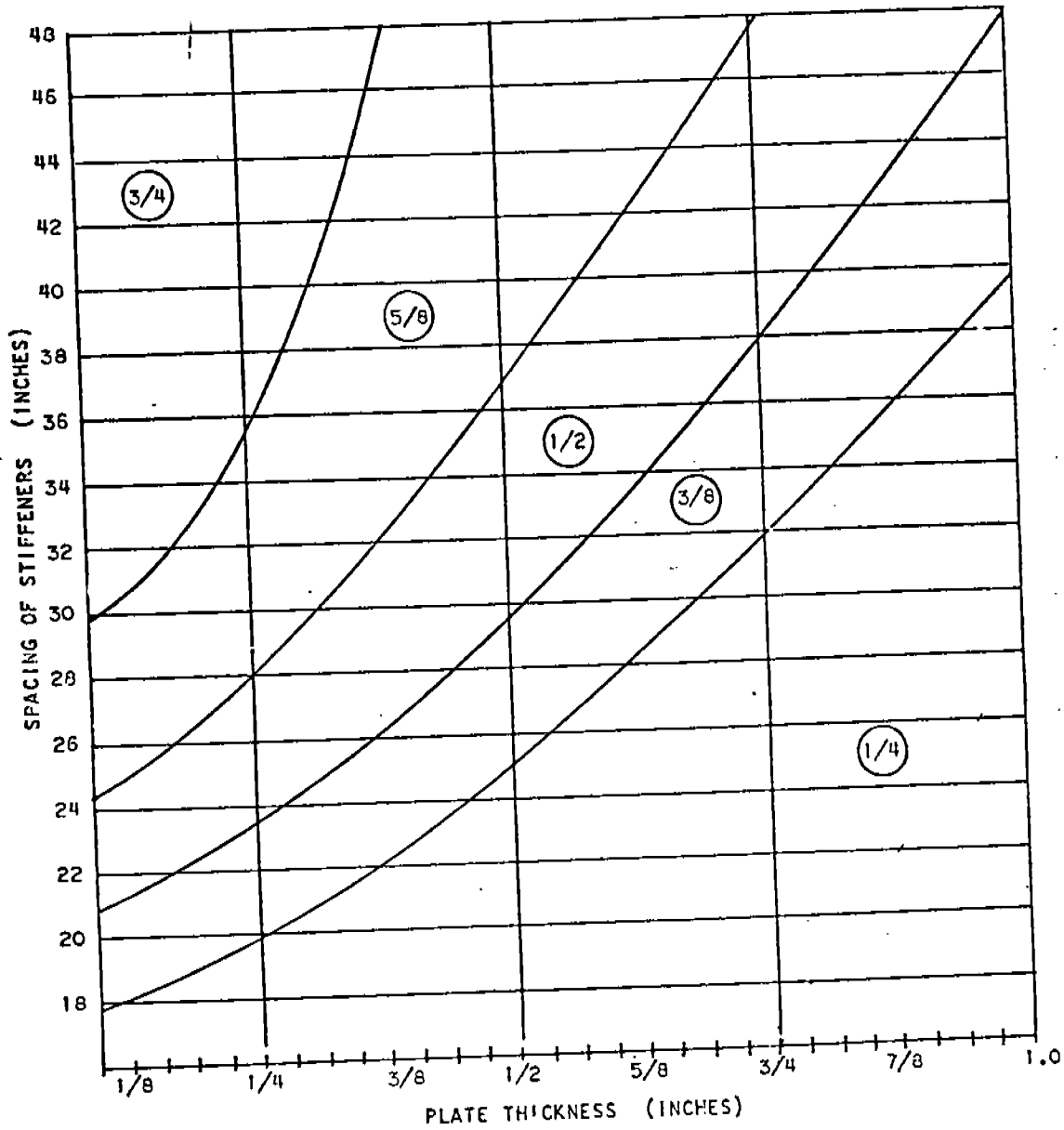

Figure 12-7. Permissible unfairness in steel welded structure.

Note: Applicable to -
 - Entire Shell
 - Uppermost Strength Deck
 - Longitudinal Strength Structure

NAVSHIPS 0900-000-1001
 1 JUNE 1969

9.3: EXISTING INTERNATIONAL STANDARDS

CONTENTS

- 9.3.1 Japanese Shipbuilding Quality Standards, JSQS, Hull Part, 1975
- 9.3.2 Production Standard of the German Shipbuilding Industry, Nov. 1974
- 9.3.3 Accuracy in Hull Construction, VIS 530, Swedish Shipbuilding Standards Center, 1976
- 9.3.4 Background Document #8-3, JSQS
English Translation of Chapter IX "Alignment and Finishing"

Japanese Shipbuilding Quality Standard
(J.S.Q.S.)
(HULL PART.)

(Prepared by:

The "Research Committee
on Steel Shipbuilding" of the
Society of Naval Architects of Japan)

1975

CONTENTS





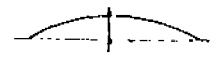

I	MATERIAL	9-66
II	MARKING	9-67
III	GAS CUTTING	9-67
IV	FABRICATION	9-69
V	SUB ASSEMBLY	9-72
VI	ACCURACY OF ROLL FORM	9-74
VII	RIVETING	9-75
VIII	WELDING	9-77
IX	ALIGNMENT AND FINISHING	9-78
X	DEFORMATION	9-83
XI	MISCELLANEOUS	9-85

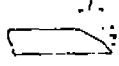

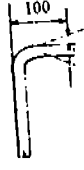

Division		MATERIAL	
Section	Subsection	Item	Remarks
Surface flaw	Pit	Grade of pit Area Ratio 	<ol style="list-style-type: none"> Grade A is to be considered so slight that any repair is unnecessary. Grade B is of medium disorder and is to be repaired if necessary. Grade C is remarkable in disorder and needs some repair. Boundary lines of grade-B are included in grade A or respectively. The area ratio of pit denote D in the abscissa means the percentage of pitted areas where surface appearance is unsatisfactory for practical use. For skin plate Percentage of pitted area = $\frac{\text{Area of pit}}{\text{Total area of a plate}}$ Repair method of surface flaw Depth of defects : d plate thickness : t d < 0.07t removed by grinding (but in no case d < 3 mm) 0.07t < d < 0.2t grinding followed by welding
	Flaking	Grade of surface flaking Area Ratio 	<ol style="list-style-type: none"> Grade A is to be considered so slight that any repair is unnecessary. Grade B is of medium disorder and is to be repaired if necessary. Grade C is remarkable in disorder and needs some repair. Boundary lines of grade B are included in grade A or C respectively. Repair method of surface flaw Depth of defects : d plate thickness : t d < 0.07t removed by grinding (but in no case d < 3 mm) 0.07t < d < 0.2t grinding followed by welding
Casting Steel	Defects of Casting steel.	In case where defect is over 20% of thickness, or over 25mm of depth and 150 mm of length.	In case where cavity crack and other injurious defects are found, after removing the defects, it is to be checked by dye penetration inspection, magnetic inspection, or ultrasonic inspection and to be repaired by adequate method.
Lamination	Local Lamination		In case where the range of lamination is limited, it can be chipped out and built-up by welding as shown in (a). In case where the range of lamination is limited also, but is near the plate surface, it is preferable to make the built-up welding as shown in (b). It must be carefully examined whether the procedure is acceptable or not in case where the degree of the lamination is more severe and defective.
	Severe lamination, requiring a local exchange of plate		It is recommended to exchange locally the plate, in case where the range of lamination is fairly extensive. The standard minimum breadth of plate to be exchanged : Shell and strength deck 1,000mm Not under large constraint 800mm Other structural members 300mm The whole plate must be exchanged in case where the degree of lamination is very severe and wide in its extent.

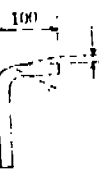

Division		Marking			UNIT : mm
Section	Sub-section	Item	Standard range	Tolerance limits	
Cutting line and fitting line compared with correct ones	General members	Size and shape, compared with correct ones.	± 2	± 3	Especially for the depth of floor and girder of double bottom.
			± 1.5	± 2.5	
		Corner angle, compared with correct ones.	± 1.5 1,000	± 2 1,000	
		Curvature 	± 1	± 1.5	
		Location of member and mark for fitting compared with correct one.	± 2	± 3	
		Block marking (Panel block), compared with correct one.	± 2.5	± 3.5	
		Location of member for fitting to block compared with correct one.	± 2.5	± 3.5	

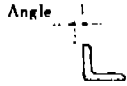
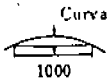
Division		Gas cutting			UNIT : mm	
Section	Subsection	Item	Standard range	Tolerance limits	Remarks	
Roughness	Free edge	Strength member	100 μ (2nd class)	200 μ (3rd class)	The class denoted in the brackets is in accordance with following definition published by an Gas Cutting Committee	
		Field	150 μ (3rd class)	300 μ (Out of class)		
		Others Shop	100 μ (2nd class)	200 μ (3rd class)		
		Field	500 μ (Out of class)	1,000 μ (Out of class)		
	Weld groove	Strength member				○ Special precautions are required in case where the grinding or other treatments are requested.
		Shop	100 μ (2nd class)	200 μ (3rd class)		
	Field	400 μ (Out of class)	800 μ (Out of class)			
	Others Shop	100 μ (2nd class)	1,500 μ (Out of class)		○ For angle cutting the same as the case in field.	
	Field	800 μ (Out of class)	1,500 μ (Out of class)			

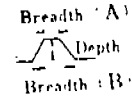
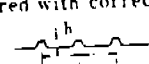

Division		Gas Cutting		UNIT: mm or Degree		
Section	Subsection	Item	Standard range	Tolerance limits	Remarks	
Notch	Free edge	1) Upper edge of sheer strake. 2) Strength deck between 0.6L and free edge of opening of shell plate. 3) Main long strength member.		Indentation ≤0	In case where it is necessary to be smoothly finished by grinder, it is to be welded up. Carefully avoid short head.	
		Longitudinal and Transverse strength members.		Indentation ≤1		
		Others		Indentation ≤3		
	Weld groove	Butt Weld	Shell plate and Upper deck between 0.6L		Indentation ≤2	Notch is to be repaired by grinder or gouging. Carefully avoid weld defects.
			Others		Indentation ≤3	
		Fillet Weld		Indentation ≤3		
An indentation is defined as the notch, in case where its depth is more than 3 times the tolerance limits of roughness.						
Dimension	Straightness of plate edge	Automatic welding Manual welding Semi automatic welding	± 0.4 ± 1.0	± 0.5 ± 2.5		
	Depth of groove		± 1.5	± 2.0		
	Length of taper		± 0.5d	± 1.0d		
	Size of member	General members compared with correct sizes.		± 3.5	± 5.0	
		Especially for the depth of floor and girder of double bottom compared with correct sizes.		± 2.5	± 4.0	
		Breadth of face bar, compared with correct size.		± 2.0	-3.0 + 4.0	
Edge preparation.	Automatic welding		± 2'	± 4'		
	Semi automatic and manual welding		± 2'	± 4'		

Division		Fabrication			UNIT : mm
Section	Subsection	Item	Standard range	Tolerance limits	Remarks
Flange Long	Breadth of flange	 Compared with correct size	± 3.0	± 5.0	
		 Compared with correct size	± 3.0 ± 2.0	± 5.0 ± 3.0	The bracketed ones show the case where strength is especially required, e.g. longitudinal members, etc.
	Angle between flange and web	 Compared with template	± 2.5 100	± 4.5 100	
	Curvature or straightness in the plane of flange	 Per 10M in length	± 10	± 25	
	Curvature or straightness in the plane of web	 Per 10M in length	± 10	± 25	
Flange Bracket	Breadth of flange	 Compared with correct size	± 3.0	± 5.0	
	Angle between flange and web	 Compared with template per 100mm in breadth of flange.	± 3	± 5.0	

Division		Fabrication			UNIT : mm
Section	Subsection	Item	Standard range	Tolerance limits	Remarks
Template for bending (plane or box shape).	Template in box shape	Location of plate edge, compared with correct one.	± 2.0	± 4.0	
		Shape of curved surface, compared with correct one.	± 2.0	± 4.0	For large one ± 5.0
	Section template	Location of check line for leveling by sight, compared with correct one. (for transverse)	± 1.5	± 3.0	
		" (for longitudinal)	± 1.5	± 3.0	
		Shape, compared with correct one.	± 1.5	± 3.0	
	Other templates	Shape, compared with correct one.	± 1.5	± 3.0	
Angles & Built up Plates.	Stringer angle	 <p>Angle</p> <p>Compared with angle gage</p>	± 1.5 Depth of Angle	± 2.0 Depth of Angle	
		 <p>Curvature</p> <p>1000</p> <p>Compared with template</p>	± 1.0 1.000	± 1.5 1.000	
	Frame & Long:	Curvature compared (with template or check line. PERIOM in length.	± 2.0	± 4.0	
		 <p>Deviation from correct form</p> <p>Correct form inscribed</p>	± 3.0	5.0	
		 <p>Deviation in flange angle</p> <p>Correct form</p>	± 1.5	3.0	
		 <p>Deviation of face plate</p>	± 1.5	± 3.0	

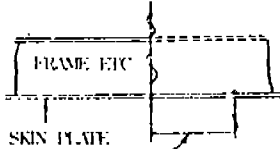

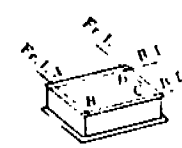
Division		Fabrication			UNIT : mm	
Section	Sub-section	Item	Standard range	Tolerance limits	Remarks	
Plates	Corrugated bulkhead	Depth of corrugation.	± 3.0	± 6.0		
		Breadth of corrugation, compared with correct ones. 	A	± 3.0	± 6.0	
			B	± 3.0	± 6.0	
	Corrugated wall	Pitch of corrugations.	± 6.0	± 9.0	In case where it does not connect with others.	
		Depth of corrugation. Compared with correct ones. 	± 2.0 ± 2.5	± 3.0 ± 5.0		In case where it connects with others.
	Cylindrical structure (mast, post etc)	Diameters 	$\pm \frac{D}{200}$ But, Max. ± 5.0	$\pm \frac{D}{150}$ But, Max. ± 7.5		
	Curved shell plate	In regard to the check line. (for longitudinal)	± 2.5	± 5.0		
		" (for transverse)	± 2.5	± 5.0		
		Gap between shell plate and section template.	± 2.5	± 5.0		
	Line heating method	Maximum heating temperature on surface.	Water cooling just after heating	under 650 °C		
Air cooling after heating			under 900 °C			
In case of moment air cooling and subsequent water cooling after heating			under 900 °C starting temperature of water cooling to be under			

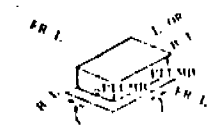
Division		Sub-assembly			UNIT : mm	
Section	Subsection		Standard range	Tolerance limits	Remarks	
Accuracy of Dimensions	Flat plate Sub-assembly	Breadth of sub-assembly	± 4	± 6	Cut, when too long.	
		Length of sub-assembly	± 4	± 6	Cut, when too long.	
		Squareness of Sub-assembly	4	8	Measured difference of diagonal length at final marking lines. When the difference is over the limits, correct the final marking line.	
		Distortion of Sub-assembly	10	20	Measured on the face of web-beam or girder.	
		Deviation of Interior members from skin plating	± 5	± 10	Excluding the case when interior members are connected by lapped joint.  ACCURACY OF THIS DIMENSION	
	Curved plate Sub-assembly	Breadth of Sub-assembly	± 4	± 8	Measured along the girth. Cut, when too long.	
		Length of sub-assembly	± 4	± 8	Cut, when too long.	
		Distorsion of Sub-assembly	10	20	Measured on face of web or girder. Correct the final marking line, when the distorsion exceed the limits.	
		Squareness of Sub-assembly	10	15	Measured difference of diagonal length at final marking lines.	
		Deviation of interior members from skin plating	The same as for the flat plate sub-assembly			
	Plate Block Sub-assembly	Breadth of each panel	The same as for the flat plate sub-assembly			
		Length of each panel				
		Squareness of each panel				
		Distortion of each panel				
		Distortion of interior members from skin plating				

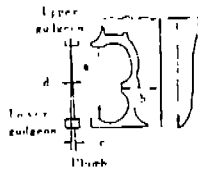

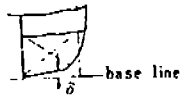
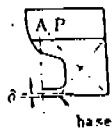

Division		Sub-assembly		UNIT : mm					
Section	Sub-section	Item	Standard range	Tolerance limits	Remarks				
Accuracy of Dimensions	Plate Block Sub-assembly	Twist of Sub-assembly	10	20	Measured as follows :  The point A, B and C are established in the same plane, then measured the deviation of the point D from that plane. May re-assemble partially when the deviation exceed the limits.				
		Deviation of upper lower panel from f. or B. L.	5	10					
		Deviation of upper lower panel from F R.L.	5	10	 ACCURACY OF THIS DIMENSION				
	Curved plate Block Sub-assembly	Breadth of each panel	The same as for the flat plate Sub-assembly						
		Length of each panel							
		Distortion of each panel							
		Deviation of interior members from skin plating							
		Twist of Sub-assembly					15	25	The same as for the flat plate Sub-assembly
		Deviation of upper lower panel from f. or B.L.					7	15	Re-assemble partially when the deviation exceed the limits.
	Deviation of upper lower panel from F.R.L.	7	15						
Block Sub-assembly including Stern frame	Distance between upper lower gudgeon (a)	± 5	± 10						



Division		Sub-assembly			UNIT : mm
Section	Sub-section	Item	Standard range	Tolerance limits	Remarks
Accuracy of Dimensions	Block Sub-assembling including Stern frame	Distance between aft edge of boss and aft peak bulkhead (b)	± 5	± 10	 (c): twist of plane including ℓ .
		Twist of Sub-assembly (c)	5	10	
		Deviation of rudder from shaft ℓ (d)	4	8	
		Others	The same as for curved plate block Sub-assembly		
	Rudder	Twist of rudder plate	6	10	Correct or re-assemble partially
		Others	The same as for the curved plate block Sub-assembly		
	Special Sub-assemblies	Main engine bed	Flatness of top plate of main engine bed	5	10
			Breadth and length of top plate of main engine bed	± 4	± 6
		Others	The same as for flat plate block Sub-assembly		

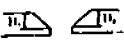

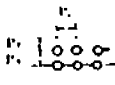

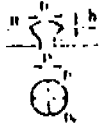
Division		Accuracy of hull form			UNIT : mm
Section	Sub-section	Item	Standard range	Tolerance limits	Remarks
Principal Dimensions	Length	Length between Perpendiculars	± 50 Per 100m	max100	Applied to ships of 100 meters length and above. For the convenience of the measurement the point where the keel is connected to the curve of the stem may be substituted for the fore perpendicular in the measurement of the length.
		Length between Aft-perpendicular and forward bulkhead of engine room	± 25	not defined	For the accuracy in accordance with the shaft length.
	Breadth	Molded breadth Amidships	± 15	not defined	Applied to ships of 15 meters breadth and above. Measured on the upper deck.
	Depth	Molded depth Amidships	± 10	max10 for minus side	Applied to ships of 10 meters depth and above.

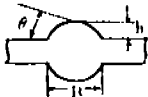
Division		Accuracy of hull form			UNIT : mm
Section	Sub-section	Item	Standard range	Tolerance limits	Remarks
Deformation of hull form	Flatness of Keel	Deformation for the whole length	± 25	not defined	Ups (-) and Downs (+) against the check line of keel sighting.
		Deformation for the distance between two adjacent bulkheads	± 15	not defined	Sighting by the transit or slits. Local unfairness, which see DIVISION: Deformation
	Cocking-up	Cocking-up of Fore-body 	± 30	not defined	Ups (-) and Downs (+) against the check line of the keel at the foremost frame on the flat part of the keel.
		Cocking-up of Aft-body 	± 20	not defined	Ups (-) and Downs (+) against the check line of the keel at the aft-perpendicular.
	Rise of Floor	Rise of floor amidships 	± 15	not defined	The height of the lower turn of the bilge, compared with the planned height. Measured from the plane passing through the outer surface of the keel plate.

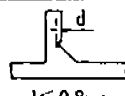
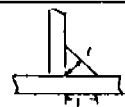
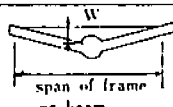

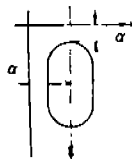

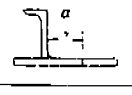
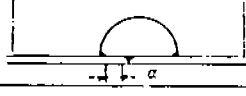
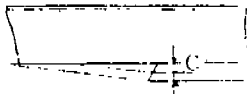
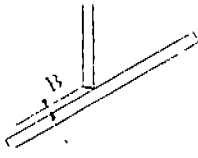

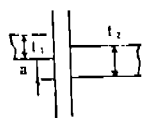
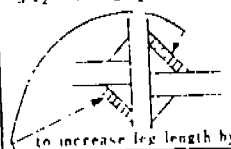
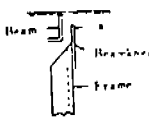
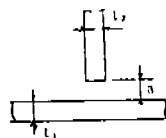
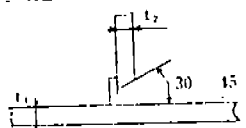
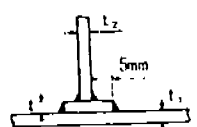
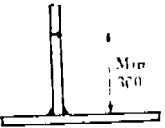

Division		Riveting			UNIT : mm
Section	Sub-section	Item	Standard range	Tolerance limits	Remarks
Rivet Hole	Hole	Diameter compared with correct size. $\Delta \phi$ Difference from standard (ϕ)		$2-16 \quad 0.25 \Delta \phi \leq 0.25$ $17-24 \quad 0.5 \Delta \phi \leq 0.15$ $25-32 \quad 1.0 \Delta \phi \leq 0.0$	Relation between rivet dia (d) and hole dia (ϕ) $d = 16 \quad \phi = d + 1$ $d = 25 \quad \phi = d + 1.5$ $d = 32 \quad \phi = d + 2$
	Counter-sunk	Depth compared with correct size. ΔH = Difference from standard (H) 	$-0.5 \leq \Delta H \leq 1.0$	$-0.5 \leq \Delta H \leq 1.5$	

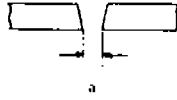
Division		Riveting			UNIT : mm
Section	Sub-section	Item	Standard range	Tolerance limits	Remarks
Rivet Hole	Counter-sunk	Inclination $\Delta H' = H_1 - H_2$ 	$\Delta H' \leq 1.0$	$\Delta H' \leq 2.0$	
	Faying Surface contact	Clearance 	$\Delta C \leq 0.2$	$\Delta C \leq 0.3$	
	Unfairness Through holes	Discrepancy 	$\Delta G \leq 0.5$	$\Delta G \leq 1.0$	$\Delta G > 1.0$ = To be reamed $\Delta G \geq 3.0$ = To be redrilled after building up by weld
	Pitch	Deviation from marking point 	$\Delta P_1 = \Delta P_2 = \Delta P_3 = \Delta P$ $\Delta P = \pm 2$	$\Delta P = \pm 3$	
	Counter-sunk head	Edge height = h 	$0 \leq h \leq 3.0$	$0 \leq h \leq 5.0$	
	Point	Deformation $\delta = D_1 - D_2$ Over lap $\Delta D = D - D$ Point height = H Edge height = h 	$d \leq 19 \quad \delta \leq 2.0$ $d \geq 22 \quad \delta \leq 3.0$ $d \leq 19 \quad \Delta D \leq 5.0$ $d \geq 22 \quad \Delta D \leq 7.0$ $d \leq 16 \quad 1.5 \leq H \leq 3.0$ $d = 19, 22 \quad 3.0 \leq H \leq 4.5$ $d \geq 25 \quad 3.0 \leq H \leq 5.5$ $d \leq 19 \quad h \leq 1.0$ $d \geq 22 \quad h \leq 2.0$	$d \leq 19 \quad \delta \leq 3.0$ $d \geq 22 \quad \delta \leq 4.0$ $d \leq 19 \quad \Delta D \leq 8.0$ $d \geq 22 \quad \Delta D \leq 10.0$ $d \leq 16 \quad 1.0 \leq H \leq 4.0$ $d = 19, 22 \quad 2.0 \leq H \leq 5.5$ $d \geq 25 \quad 2.0 \leq H \leq 6.5$ $d \leq 19 \quad h \leq 2.0$ $d \geq 22 \quad h \leq 3.0$	

Division		Welding		
Section	Sub-Section	Item	Tolerance limits	Remarks
Shape of bead	Height of reinforcement Breadth of bead flank angle		 h : not defined B : not defined $\theta \leq 90^\circ$	 In case where θ is over 90° , it is to be repaired by grinding or welding to make $\theta = 90^\circ$
	Under cut 'butt' weld	Skin plate and face plate between 0.6L \times	over 90mm continuous $d \leq 0.5mm$ 	to be repaired by using fine electrode. 'carefully avoid short bead for higher tensile steels'
		Others	$d \leq 0.8mm$	
	Under cut 'fillet' weld		 $d \leq 0.8mm$	
Leg length	Compared with Correct ones (L, ρ)	 L : Leg length ρ : Throat depth $> 0.9L$ $- 0.9L$	In case where it is over tolerance limits, weld up over it. (carefully avoid short bead for higher tensile steels)	
Distortion of welding joint	Angular distortion of welding joint.	Skin plate between 0.6L \times	 $W \leq 6mm$	In case where it is over tolerance limits, it is to be repaired by line heating or to be re-welded after cutting and re-fitting.
		Fore and Aft shell plating and Transverse strength member	$W \leq 7mm$	
		Others	$W \leq 8mm$	
Short bead		Higher tensile steel (50kg/mm ² class)	$\geq 50mm$	In case where short bead is used unavoidably, preheating is necessary at $100 \pm 25^\circ C$. When short bead is made erroneously, remove the bead by grinding, and weld over 50mm after checking root crack or heel crack.
		Mild steel (including tack welding, repair welding)	not defined	
Arc strike		Higher tensile steel (50kg/mm ² class) and Grade E steel of mild steel	prohibit arc-strike	In case where arc-strike is made erroneously, one of the following repair method is applied. (1) weld over 50mm bead on the arc-strike. (2) apply post heating at $350 \sim 650^\circ C$ (3) remove the hardened zone by grinding.

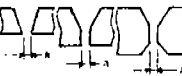
Division		Alignment and Finishing		UNIT : mm
Section	Subsection	Item	Tolerance limits	Remarks
Minimum distance of weld to adjacent weld or rivet	Butt weld to butt weld		$\alpha \geq 30$	Detail of the construction is decided in mold loft or application planning section, in case where it is not described in the approved plan. The numerals of this division indicate final condition.
			$\alpha \geq 0$	
	Butt weld to fillet weld		$\alpha \geq 10$ (main structure) $\alpha \geq 0$ (Super-structure)	
			$\alpha \geq 5$	
Gap between members	Gap between plate and stiffening member	Stiffening member located perpendicularly to plate. 	$C \leq 3$	Gap between members is to be less than 3 mm, in case where it is inevitable to make flush the plate surface of non-stiffening side.
		Stiffening member located obliquely to plate. (without edge preparation) 	$B \leq 3$	
	Through piece and tight plate  $C_1 > C_2$	$C_1 \leq 3$		

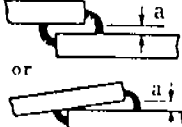
Division		Alignment and Finishing			UNIT: mm
Section	Sub-section	Item	Standard range	Tolerance limits	Remarks
Fitting Accuracy	Alignment of fillet joint  a : Difference t : thickness $t_1 > t_2$	Strength member		$a \leq \frac{1}{2} t_2$	$\frac{1}{2} t_2 \leq a < \frac{1}{2} t_1$  to increase leg length by 10. $a > \frac{1}{2} t_2$ re-fitting
		Others	$a \leq \frac{1}{2} t_2$	$a : \frac{1}{2} t_2$	$a > \frac{1}{2} t_2$ re-fitting
	Differences between the beam and the frame  a : Difference		$a \leq 3$	$a \leq 5$	The numerals indicates the tolerance that the members can be welded by pulling without taking apart.
	Gap before welding 	Fillet weld	$a \leq 2$	$a \leq 3$	① $3 < a < 5$ Rule leg 'a-2'
					② $5 < a < 16$ Welding with bevel preparation or Liner treatment. Welding with bevel preparation  To make level edge of web to 30° 45°, attach the backing strip, and after welding, remove it. Then weld the opposite side. Liner treatment  $t_2 \leq t_1$
					③ $a > 16$ Liner treatment or partial renew.  Min 30

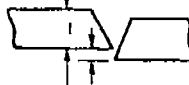

Division		Alignment and finishing		UNIT : mm	
Section	Sub-section	Item	Standard range	Tolerance limits	Remarks
Fitting Accuracy	Gap before Welding	Butt weld (manual welding)  a : Gap	$2 < a < 3.5$	$a \leq 5$	① $5 < a < 16$ After welding with backing strip, remove it and finishing weld after back chipping.  Backing strip ② $16 < a < 25$ Welding up with edge preparation or partial renew. ③ $a > 25$ Partial renew.
		Butt weld automatic welding 1. Both side submerged arc welding 	$0 < a < 0.8$	$0 \leq a \leq 5$	In case where it is predicted to be burned through, sealing head is to be done.
		2. Submerged arc welding with manual or CO ₂ welding 	$0 < a \leq 3.5$	$0 \leq a \leq 5$	In case where a is over 5mm, see manual welding.
		3. One side submerged arc welding with flux copper backing or flux backing 	$0 < a < 1.0$	$0 \leq a \leq 3$	In case where it is predicted to be burned through, sealing head is to be done.
		4. One side submerged arc welding with fiber asbestos backing 	$0 \leq a < 4$	$0 \leq a \leq 7$	In case where it is predicted to be burned through, it is adjusted by scattering of metal powder or sealing head is to be done.
		Lap weld  or 	$a \leq 2$	$a \leq 3$	① $3 < a \leq 5$ Increased leg length Rule leg $\geq a$ ② $a > 5$ Re-fitting
Alignment of butt joint  a : Difference t : Thickness (thinner plate)	Strength member		$a < 0.15t$ (max 3)	$a < 0.15t$ or $a > 3$ Re-fitting	
	Others		$a < 0.2t$ (max 3)	$a > 0.2t$ or $a > 3$ Re-fitting	

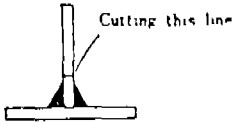
Division		Alignment and finishing			UNIT : mm
Section	Sub-section	Item	Standard range	Tolerance limits	Remarks
Finishing up the traces of temporary pieces	Part to be good appearance.	Outside surface of shell plates. Exposed deck. Exposed super-structure	Chipping		
	Not necessary to be good appearance.	Inside of tank Inside of ceiling Deck to be shield with deck composition etc.	Chipping only particularly conspicuous part when finishing		
Surface defect	Part to be good appearance.	Ditto	Allowable under-cut on the trace of piece. Depth ≤ 1 and Length ≤ 10		Weld up and to make flush by chipping.
	Not necessary to be good appearance.	Ditto	Correct only particularly conspicuous defect.		Only weld up, but not necessary to chip.

Division		Alignment and Finishing	
Section	Sub-section	Scope of staging sockets and lifting eye piece to be removed	Remarks
Staging sockets	in tank	not to be removed	Method of removing 1. Parts of ruining appearance and passages to be flush to base plate. 2. Others to be done by gas cutting at the bond zone. 
	in engine room	Parts of ruining appearance and passages.	
	in hold	Under side of hold and hatch coaming.	
	exposed parts of shell, upp. DK etc	To be removed.	
Lifting eye piece	in tank	Not to be removed except disturbance of passage	but parts being especially important for strength to be soft-toe.
	in engine room	Parts of ruining appearance and passages.	
	in hold	To be removed except back of deck.	
	exposed parts of shell, upp. DK etc.	To be removed.	

Division		Alignment and Finishing			
Section	Sub-section	Item	Tolerance limits	Remarks	
Treatment of holes made erroneously	D < 200	Skin plate	(A)	Open the hole to over 75mm	
			or (B)	Open the hole to over 200mm	
	D ≥ 200	Skin plate	(B), (C) or (D)	Open the hole to over 200mm	
			Others	(B)	Method of treatment.
	Serration, Scallop Slot.			(B) or (C)	(A) : Spigot patch. (B) : Closing by butt weld. (C) : Closing by lapping piece.
				(B) or (C)	(Closing plate to be same thickness of base plate) (f)
				In case where it is impossible from structural point of view to open the hole over 200mm, it is to be used carefully by low hydrogen electrode after pre-heating and to be done by radiographic examination or ultrasonic inspection.	

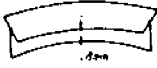
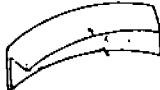
Division		Deformation		UNIT : mm	
Section	Sub-section	Item	Standard Range	Tolerance limits	Remarks
Unfairness	Shell plate	Parallel part side	4	6	
		Parallel part bottom	4	6	
		Fore and aft part	5	7	
	Double bottom tank top plate		4	6	
	Bulkhead	Longl Bulk head Trans " Swash Bulkhead	6	8	
	Strength deck	Parallel part (Between 0.6LX)	4	6	
		Fore and aft part	6	9	
		Covered part	7	9	
	Second deck	Bare part	6	8	
		Covered part	7	9	
	Fore-castle deck Poop deck	Bare part	4	6	
		Covered part	7	9	
	Super Structure deck	Bare part	4	6	
		Covered part	7	9	
	Cross deck		5	7	
	House wall	Out side wall	4	6	
		Inside wall	4	6	
		Covered part	7	9	
	Interior member	Web of girder, trans	5	7	
	Floor and girder of double bottom		6	8	

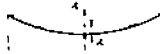
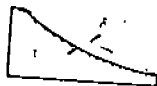
Division		Deformation			UNIT: mm
Section	Sub-section	Item	Standard Range	Tolerance limits	Remarks
Miscellaneous	Distorsion of girder and trans (at the part of upper edge and flange)	Length of span	5	8	
	Distorsion of longl. trans frame, beam and stiffner. (at the part of flange)	$l \leq 1,000$	5	8	
		$1,000 < l < 3,500$	$3 \pm \frac{2}{1000}$	$6 \pm \frac{2}{1000}$	
		$l \geq 3,500$	10	13	
	Distorsion of H pillar between decks.		4	6	
	Distorsion of cross tie.	Distorsion of fore and aft direction, δ (cross tie only)	6	10	
		Distorsion of fore and aft direction, δ (cross tie + trans web)	12	16	
Distorsion of tripping bkt and Small stiffener with web plate.	Distorsion at the part of free edge.			1	
Distorsion of face plate.			$a = 2 \pm \frac{b}{100}$	$a = 5 \pm \frac{b}{100}$	

Division		Miscellaneous			UNIT : mm
Section	Sub-section	Item	Standard range	Tolerance limits	Remarks
Painting for welded & riveted joint at tightness test or construction inspection	Sub assembly & assembly welded joint		Paint after hull block inspection.		
	Erection welded joint		Paint after tightness test. Butts of SKIN PLATES are coated wash primer before final construction inspection. Paint before tightness test, when tanks given special protective coating are hydraulically tested.	Butts of skin plates are coated after final construction inspection and before leak test.	
	Riveted joint		Paint after tightness test.		
Draft Mark	In regard to the template		± 1.0	± 2.0	
Freeboard Mark	In regard to the template		± 0.5	± 0.5	

Division		Miscellaneous			
	Sub-section	Item	Standard range	Tolerance limits	Remarks
Hatch Coaming	Principal dimensions of hatch coaming	Length	± 5	± 10	
		Breadth	± 5	± 10	
		Difference of diagonal length.	± 10	± 15	
	Deformation of horizontal stiffener	End coaming	± 3	± 5	
		Side coaming	± 5	± 8	
		Deformation per one meter (random)	± 2	± 3	
Opening of entrance	Opening of steel door	Breadth and Height	± 4	± 7	
		Sill height	0-15	-10-+30	
		Deformation	± 2 1,000	± 3 1,000	
	Opening of deck (Through type)	Breadth	± 2	± 3	
		Length	± 3	± 3	
	Opening of deck (not Through type)	Breadth	-3-+2	-5-+3	
		Length	-3-+2	-5-+3	

T r a n s l a t i o n

APPENDIX 9.3.2

Production Standard
of the German Shipbuilding Industry

Issued: Nov. 1974

Verband der Deutschen Schiffbauindustrie e.V.

I N D E X

SECTION

Page No.

Section 1	Surface defects and laminations	9-89
Section 2	Edge preparation	9-91
Section 3	Welds	9-92
Section 4	Component part production	9-95
Section 5	Subassembly	9-97
Section 6	Fairing work	9-100
Section 7	Final work	9-102
Section 8	Tightness test	9-104
Section 9	Hull - main dimensions	9-106

Surface Defects and Laminations

1.1 Depressions, Indentations, Scores, Bubbles, Scale and Laminations

(In accordance with the recommendations for
plate surfaces issued by the Association of the
German Shipbuilding Industry)

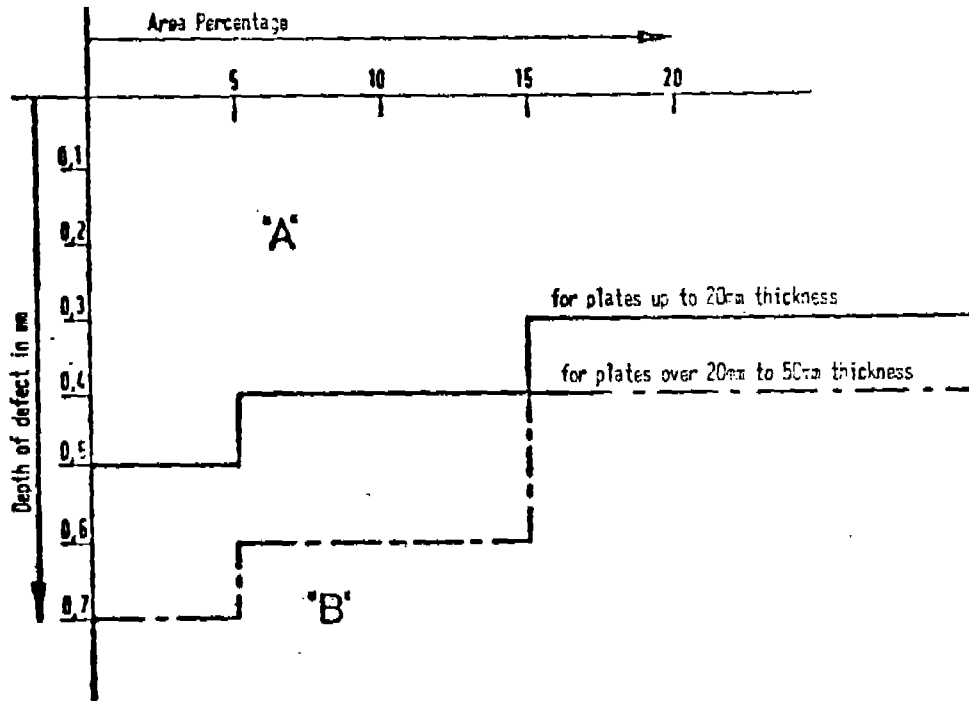

- 1.1.1 Area "A" - covering plates up to 20 mm in thickness above the continuous line, and plates over 20 to 50 mm in thickness above the dot-and-dash line - contains minor surface defects. No repairs will be made.
- 1.1.2 Area "B" indicates the surface defects beyond "A". These will be repaired as follows:

Surface Defects
and Laminations

- 1.1.2.1 Defects showing depths of up to 7 % of the nominal plate thickness, but 3 mm max., will be ground out; defects of greater depths will, in addition, be filled by welding.
- 1.1.2.2 In case the defects gouged or ground out indicate a depth greater than 20 % of the nominal plate thickness, and cover more than 2 % of the plate area, this plate section has to be renewed as defined in 1.3.
- 1.1.3 The area percentage is the ratio between the defective zone and the total plate area of the faulty side. The defective zone is enclosed by a line spaced 30 mm from the defects.

- 1.2 Individual laminations on plate edges which do not appear before preparation and do not indicate widths and lengths in excess of 300 mm, will be repaired by gouging and welding the plate edge provided that the stress - for instance, in the direction of thickness - permits this to be done.

In the event of laminations accumulating, the relative plate sections will be replaced.

- 1.3 Minimum width of plate sections to be replaced
The minimum length or width of the plate sections to be replaced is to be:

$$200 \text{ mm} + 4 \times \text{plate thickness.}$$

In the case of appearance essential structural members, a plate section is normally replaced in the length of a frame distance.

Edge Preparation

2.1 Permissible unevenness on free edges

- 2.1.1 Depth of torch scores of up to 0.5 mm:
On highly stressed free edges of structural members essential for strength.
Depth of torch scores of up to 1 mm:
On all other members.
- 2.1.2 Individual notches of up to 0.5 mm which are not sharp:
For instance, caused by torch failures occurring on the free edges of structural members as described in 2.1.1.
Notches of up to 3 mm caused by torch failures :
For all other members.
- 2.1.3 Burned edges occurring during the cutting process will, in general, not be ground.
- 2.1.4 Burrs caused by roller or hammer shears will not be ground.

Welds

3.1 Minimum distance of weld from adjacent seams

3.1.1 Butt seam to butt weld.

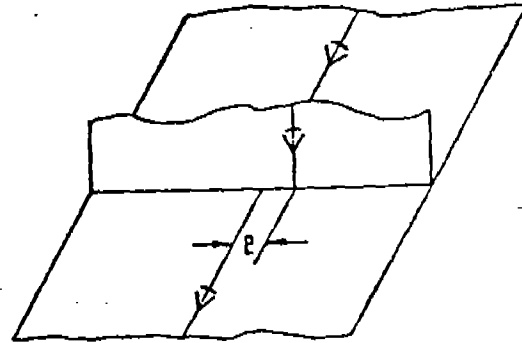
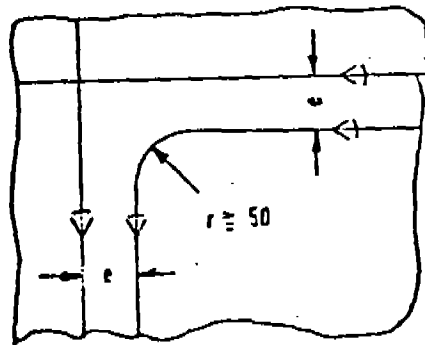

Seam spacing.

$e \geq 50 + 4s$ s = plate thickness.
If a web crosses the seam, "e" may also be zero.

3.1.2 Butt seam to fillet weld

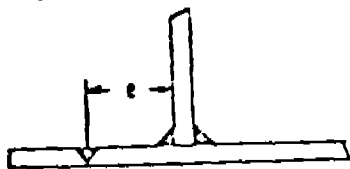

$$e \geq 30 + 2s$$

$$e \geq 10$$

Recutting of the hole is to be carried out only if this does not affect the structural member. (torch scores, again subject to heat etc.)

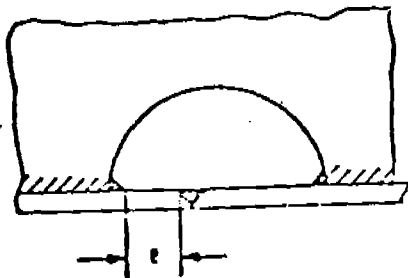

3.1.3 In special cases, even smaller distances can be agreed.

W e l d s

3.2. Weld seams

- 3.2.1. Permissible deviation from specified dimension "a" with fillet welds:
Minus $0.3 + 0.05 a$ for 10 % of the seam length, in individual places up to 2 mm max.
Minus $0.2 + 0.05 a$ for 100 % of the seam length, in individual places up to 1 mm max.
- 3.2.2. Undercuttings with fillet welds and butt seams can be 10 % of the plate thickness but not more than 1.5 mm, provided the stress is parallel to the undercutting.
- 3.2.3. If the stress is vertical to the undercutting, the latter can be 5 % of the plate thickness but not more than 1.0 mm.
- 3.2.4. Lacking root and cover passes are permissible:
At subordinate structural members, up to 10 % of the seam width but 1.5 mm max.
At highly stressed structural members, up to 5 % of the seam width but 1.0 mm max., sporadic.
- 3.2.5. X-ray test of weld seams.
Concerning the X-ray test, the inner quality of weld seams is dependent on the seam stress. The IIW catalogue may be used as a guide, as under:
- Permissible colours at highly stressed weld seams within 0.4 L:
Black, blue, and conditionally green (except for slack inclusions in seam crossings, and continuous root defects).
With other structural members which are required to be subjected to X-ray testing:
Black, blue, green.
- With subordinate members:
Black, blue, green and conditionally brown.
- 3.2.6. Surface pores in non-watertight seams are permissible in limited number.

W e l d s

3.3 Welding at minimum temperatures

3.3.1 When suitable measures have been taken, welding of ordinary strength hull structures steel is generally permissible at ambient temperatures below 0°C.

3.3.2 In general, less important structural members of standard shipbuilding steel of up to 15 mm in thickness can be welded without preheating at temperatures of up to minus 10 C.

3.4 Weld spatter

Weld spatter will not be removed.

(This does not apply to structural members which due to special protective coating have been reduced in thickness)!

4.1

4.1

4.1.

4.1.

Component Part Production

4.1 Permissible dimensional variations of fabricated profiles

All values refer to the specified dimension!

4.1.1 Flanges (except on buckling stiffeners and brackets)

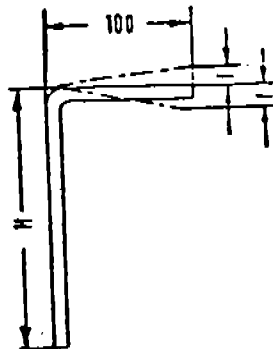

Width of flange:

- 5 mm for 100 mm
- + not limited

Depth of web "H"

- 5 mm for 100 mm
- + not limited

Warping "F"

- \pm 5 mm for 100 mm.

4.1.2 Fabricated girders

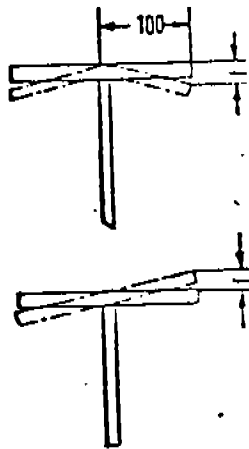

Face plate offset:

$$f = \pm 5 \text{ mm for } 100 \text{ mm}$$

Warping

$$f = \pm 5 \text{ mm for } 100 \text{ mm}$$

For width of face plate and depth of web, refer to 4.1.1.

4.1.3 Corrugated bulkheads (to be measured at points of connection!

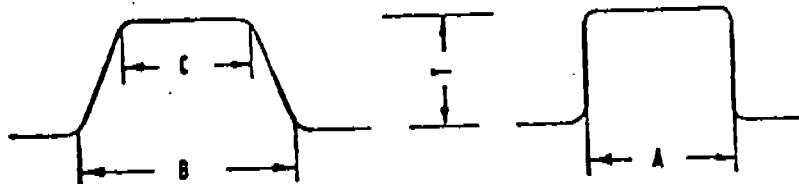

For "A" and "T" nominal dimension
 \pm 1/2 plate thickness.

For "B" and "C" not limited.

Component Part Production

4.2 Masts, posts and large cylindrical forms
(Under consideration of DIN 1626, sheet 4).

4.2.1 Deviation from diameter
Up to 1000 mm dia = $\pm (0.005 d_a + 1)$ mm

Above 1000 mm dia = ± 6 mm

4.2.2 Deformation.
Ovality 2 %
Straightness: not tolerated

Subassembly

5.1. Permissible distortion of beams, frames, girders and stiffeners

5.1.1. Deviation from the straight line referred to the length between 2 points of support.

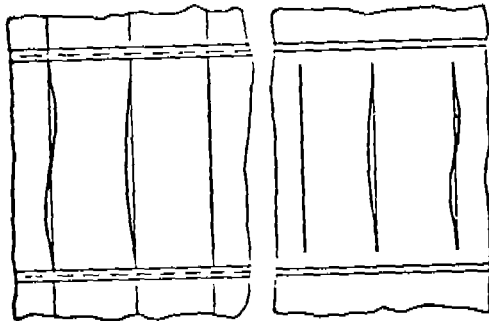

8 mm for lengths of up to 1000 mm
 $6 \text{ mm} + \frac{2 \times \text{length}}{1000}$ for
lengths of up to 3500 mm,
13 mm for lengths over 3500 mm

5.1.2. Permissible warping (profile to plate)

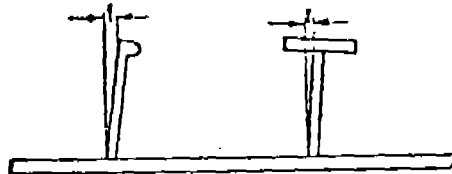

With profiles of 200 mm	10 mm
500 mm	18 mm
1000 mm	25 mm

Intermediate values must be interpolated.

5.1.3. For deviations of fabricated profiles, refer to section 4.1.

5.1.4. Deviations of finished members from the specified dimension, refer section 6.2.

Subassembly

5.2 Assembly misalignment

- 5.2.1 Internal members (stiffenings) out of alignment by more than half the plate or profile thickness will be disconnected for a length of 50 times the value of misalignment, then faired and connected flush.
- 5.2.2 Misalignment between the beam bracket and frame of up to 5 mm can be eliminated by pressing on. Proceed as described in 5.2.1, if misalignment is in excess of 5 mm.

5.3 Assembly welds

5.3.1 Fillet weld

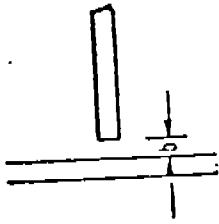

Normal welding is carried out if gap "b" is less than 3 mm.

If gap "b" is between 3 and 5 mm, the leg length of the fillet is enlarged by $b - 2$ mm.

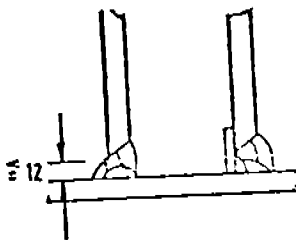

If "b" is between 5 mm and web thickness, but 12 mm max., the web will be bevelled to 45° and then welded to suit.

Backing straps may become necessary.

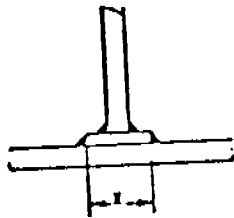

$x = 3x$ web thickness

In the event that "b" exceeds web thickness or 12 mm, the web will be connected as shown in the opposite sketch. However, the horizontal flat bar must not be subjected to tension in the direction of thickness.

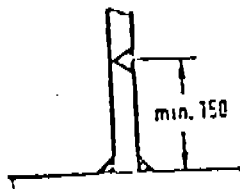

Subassembly

5.3.2 Butt welding

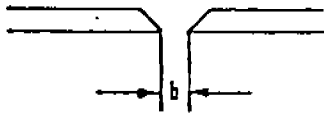

If "b" is larger than required by the Rules and does not exceed plate thickness, but 30 mm max., the gap will, in particular cases, be closed by build-up welding. Possible backing straps to be removed prior to back weld

- 5.3.3 In the case of butt welding, plate misalignment may be 2 mm or 15 % of the plate thickness, whichever is greater. For shell plates, however, this value should not exceed 4 mm.

Fairing work

6.1 Dents (deviations from the straight lines)

6.1.1 Dents in plate panel 6.1.2 Unfairness depression of weld seam.

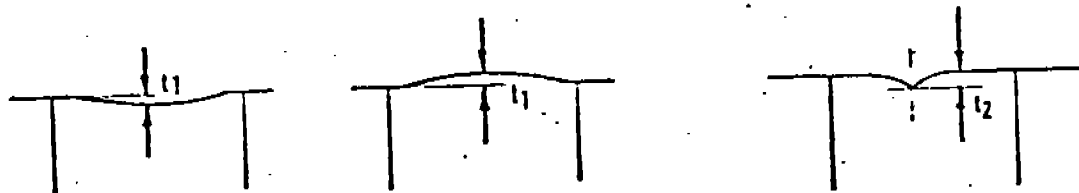

From the permissible depths of dents listed in the table below, it is evident that deeper dents will be refaired to the admissible dimensions.

Group	Area	depth t1(mm)	Unfairness depression of weld seam t2(mm)
Shell	above waterline	7	9
	below waterline	7	11
Topside Deck	free area	6	10
Superstructure Decks	covered area	9	
Tweendecks		9	10
Superstructure and house bulkheads	outer bulkheads	6	6
	inner bulkheads visible within accommodation	6	6
	inner bulkheads, outside accomod.	3	8
Superstructure decks + house tops	free area	0	0
	covered area	0	0
Double bottom		3	12
Bulkheads		3	10

Note: Bulkheads covered on both sides and decks insulated on both sides will not be faired. All the aforementioned values shall apply unless, for reasons of buckling strength, other measures

Fairing work

6.2 Deformations

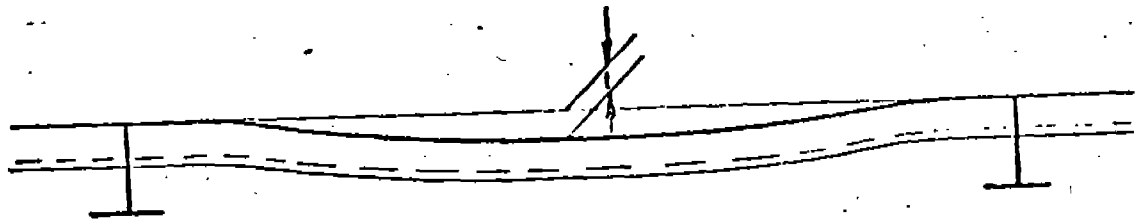

6.2.1 Deformations of subsections will be measured on the stiffeners, referred to the distance between T-webs or similar members, but 6 m max. Deviations within the stiffener distance will not be considered when measuring.

6.2.2 Deviations "t" from the straight line and the given form, respectively:

Member	"t"
Shell above water line	15 mm
below water line	18 mm
Topside deck, superstructure decks, sheer strake	15 mm
Superstructures and deck houses	15 mm
Inner bottom	18 mm
Bulkheads	18 mm
Tweendecks	15 mm

6.2.3 These dimensions do not apply if, for reasons of buckling strength, smaller values are required.

Final work

7.1 Removal of material necessary for assembly

- 7.1.1 Material will remain if it does not obstruct work.
It must be fully welded and preserved to suit.
Material will not be disturbing in the following areas:
Behind panelling;
within tanks, bunkers and cargo oil tanks;
within cargo holds except for areas lacking stiffeners;
within cargo holds of container vessels fitted with container equipment.
- 7.1.2 Unnecessary material will be cut off above the weld seam (must be fully welded and preserved to suit).
Applies to all places not falling under 7.1.1 and 7.1.3.
- 7.1.3 Unnecessary material will be entirely removed:
In visible places of shell and superstructures outside as well as on exposed decks.
Unnecessary material will be removed with the surface chiselled and smoothed.
In places of particularly high stress concentrations the special treatment applies as indicated on the plans.
- 7.1.4 Tack-welded unnecessary material will be removed after use. Possible defects occurred in the base material will be filled by welding. Remaining welds will not be removed unless they are disturbing when visible.

7.2 Openings cut for temporary purposes or by error

7.2.1 Individual openings of up to 25 mm in diameter in plates \leq 25 mm in thickness will be countersunk and closed by welding. For plates exceeding 25 mm in thickness, work is to be made as agreed with the Classification Society.

Holes in excess of 25 mm in diameter which are positioned in the shell, the topside deck and structural members subject to similar strength loads, will be enlarged to a diameter of at least $100 \text{ mm} + 5 \times \text{plate thickness}$ and closed by means of full penetration weld inserts of the same thickness, or by use of recessed flanges.

Holes in other members will be closed by butt welding, provided they must be of good appearance, and by means of overlapping plates, if not.

7.2.2 Cut-outs, slots and other openings will be closed as follows:

With butt-inserted plate in members which must be of good appearance, and where stress requires this;

Other parts with overlapping plates.

7.2.3 It may be that for areas subject to high stress concentration a different measure has to be found in cooperation with the Classification Society.

Tightness test

8.1 Tank testing

8.1.1 Tightness test:

Class Rules decide as to whether a pneumatic or hydraulic test is to be carried out.

8.1.2 Functional and strength tests may be carried out at the end of the building time in accordance with the Classification Society Rules.

8.1.3 Preservation

Considering the importance of the proper application of coatings, structural members accepted during pre-assembly can be fully coated. After installation on board, prior to the pneumatic test, the erecting seams can be primed inside and fully coated outside. If a hydraulic tightness test is carried out, all coatings may be applied inside and outside.

8.1.4 Correction of defects during and after pressure testing:
Pores will be pressure-caulked.
Rewelding will be done only if the required weld thickness is insufficient.

Smaller spots will be pressure-caulked and welded after release of pressure. Another pressure test will not be carried out.

Larger spots will be corrected by welding after release of pressure. A new pressure test will be carried out.

8.1.5 Retrofits

In the case of locally limited retrofits in tanks already tested, the relative area will be retested by saponifying and hose-testing with compressed air from the opposite side.

Tightness test

8.2 Closing Devices

8.2.1 Weathertight steel doors, windows, cargo and access hatches will be tested for tightness, by application of a jet of water at a pressure of 2.5 kg/cm^2 gauge and at a distance of 1.5 m using a nozzle of 12.5 mm in diameter.

Hose-testing of decks, shell, bulkheads, exposed deckhouse bulkheads etc. will not be carried out for welded constructions. See Section 12.13 .

8.2.2 Gastight, fire-resisting or non-weathertight doors and hatches will be tested by chalk print.

Hull - main dimensions

9.1 Permissible deviations from main dimensions

- 9.1.1 Length overall (only if maximum dimensions are defined for special sailing routes) ± 100 mm for every 100 m of length.
- 9.1.2 Breadth overall (only if maximum dimensions are defined for special sailing routes) ± 10 mm for every 10 m of breadth, but 40 mm max.
- 9.1.3 Depth
-10 mm for every 10 m
+ not determined.

9.2 Deformations

- 9.2.1 Deformations of the ship's bottom covering the area of length between the peak bulkheads.
 ± 25 mm for every 100 m.
- 9.2.2 Floor line deviation of fore and after bodies.
 $f = +50$ to -25 mm.

S

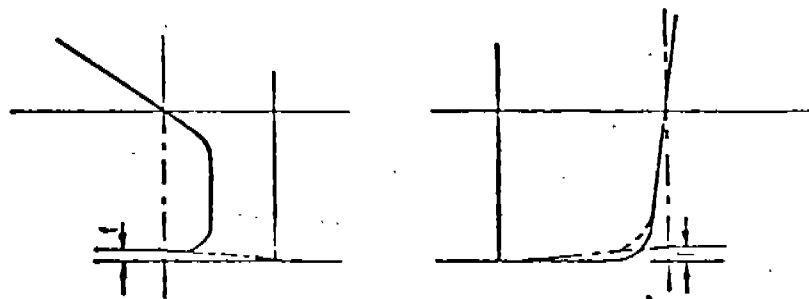

- 9.2.3 Deviation of the bilge above base line.
 $f = \pm 25$ mm for 10 m $1/2$ B, measured at $\frac{1}{10}$.

Hull - main dimensions

The lower edge of the bilge is compared with the specified height above base line.

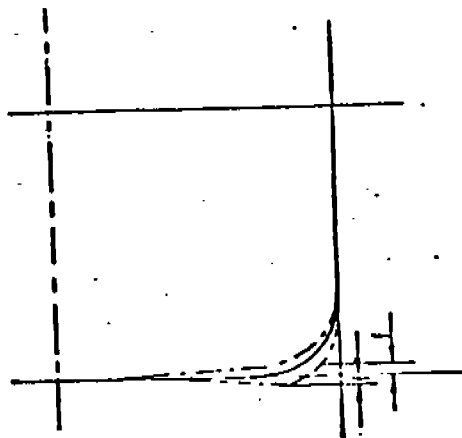

9.2.4 For 9.2.2 and 9.2.3, minimum tolerances exceeding 25 mm are to be entered in the docking plan.

9.3 Draught marks

Draught marks are marked above the bottom of keel. Marking accuracy is ± 2 mm and must be checked before the application of weld beads.

The bottom of keel is to be an averaged ideal line; ends indicating substantial deviation are to be neglected when averaging.

Noggrannhet vid skrovbyggnad

Accuracy in hull construction

APPENDIX 9.3.3

Innehåll

- Orientering
- 1 Definitioner
- 2 Passning av bräckor, kantringsbräckor, intercostala vägare, webbar, longitudinaler etc
- 3 Överlappsbräckor
- 4 Spaltöppning före handsvetsning av överlappande plåtskarvar
- 5 Spaltöppning före handsvetsning av kölfog
- 6 Spaltöppning före handsvetsning av I-fog
- 7 Spaltöppning före handsvetsning av V-fog
- 8 Spaltöppning före handsvetsning av K-fog
- 9 Spaltöppning före handsvetsning av X-fog
- 10 Kantring i däck och bordläggning
- 11 Urtag för longitudinaler och staggenomgångar
- 12 Minimiavstånd mellan stumsvetsar
- 13 Minimiavstånd mellan stumsvets och kölsvets
- 14 Oplanhet av plåt
- 15 Ytdefekter i plåt
- 16 Behandling av tillfälligt uppsatta detaljer

Orientering

Denna standard anger de maximala avvikelser från nominellt utförande som kan accepteras ur kvalitets- och hållfasthetsynpunkt vid fartygsbyggnad. Standarden anger även de åtgärder som rekommenderas vidtagas vid fall av att dessa max tillåtna avvikelser överskrides.

Angivna åtgärder gäller för såväl ordinarie stål som höghållfast fartygsstål.

Där ej annat anges gäller klassificeringsällskopets fordringar.

1 Definitioner

Mätning av kölsvets

Svets höjden a = höjden i den likbenta triangel som kan inskrivas mellan fogytorna och svetsens toppyta.

Contents

Introduction

1 Definitions

- 2 Fitting accuracy of brackets, tripping brackets, intercostal girders, webs, longitudinals etc.
- 3 Overlap brackets
- 4 Gap before manual welding of overlap
- 5 Gap before manual welding of fillet joints
- 6 Gap before manual welding of square butt joints
- 7 Gap before manual welding of single V-butt joints
- 8 Gap before manual welding of Double bevel butts
- 9 Gap before manual welding of double V-butt joints
- 10 Fitting accuracy to deck and shell plating
- 11 Hollow for longitudinals and stay passages
- 12 Minimum distance between butt to butt welds
- 13 Minimum distance between butt to fillet welds
- 14 Deformation of plate
- 15 Surface defects in plate
- 16 Handling of temporarily fitted pieces

Introduction

This standard indicates the maximum divergences from nominal design which may be accepted from a quality and stress point of view. It gives also guidance for corrections when the maximum allowable divergences are exceeded.

Stated procedures are valid for ordinary steel as well as high tensile ship steel.

Where otherwise not is stated the classification society's demand is valid.

1 Definitions

Dimensions of fillet welds

The height a of the weld = the height of the equally sided triangle that can be inscribed within the groove faces and the top surface of the weld.

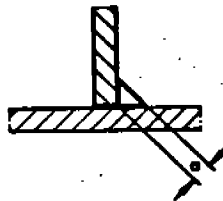

* betecknar mallinje.

Matematiska beteckningar

Betydelse	Beteckning
Lika med	=
mindre än	<
större än	>
mindre än eller lika med	< eller ≤
större än eller lika med	> eller ≥

Exempel: $t_1 \leq t_2$, betyder att t_1 är mindre än eller lika med t_2 .



*- means moulding line.

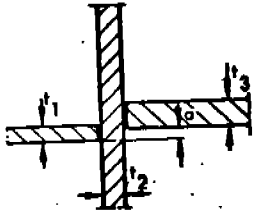
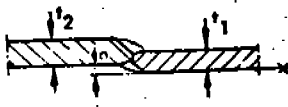
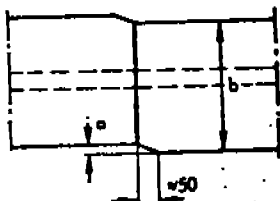
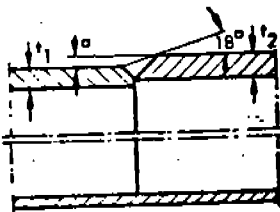

Mathematical designations

Meaning	Designation
Equal to	=
less than	<
greater than	>
less than or equal to	< or ≤
greater than or equal to	> or ≥

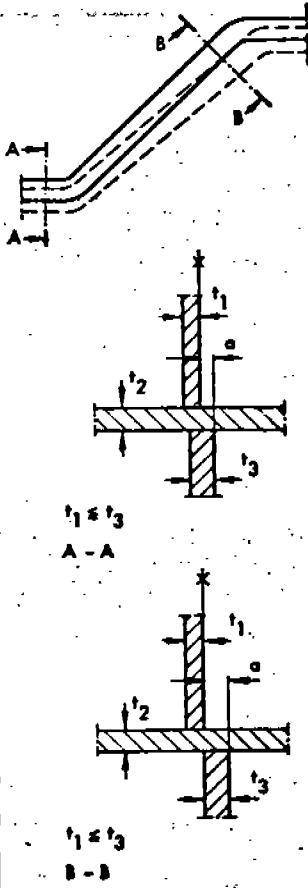
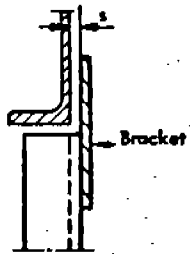

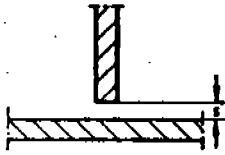

Example: $t_1 \leq t_2$ means that t_1 is less than or equal to t_2 .

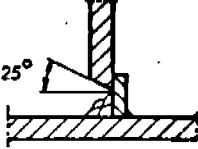
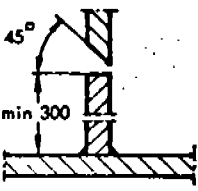
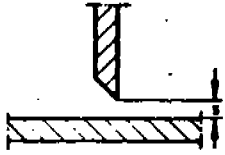

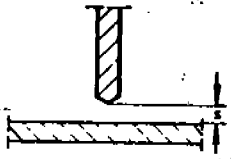
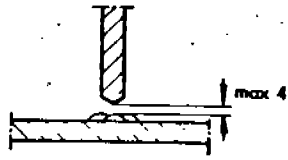
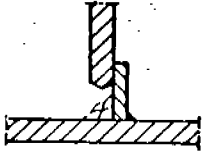
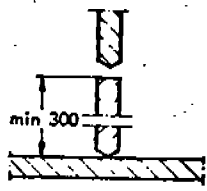
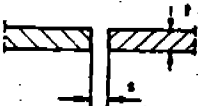

Object	Detail	Max divergences	Corrections
<p>2 Fitting accuracy of brackets, tripping brackets, intercostal girders, webs, longitudinals etc</p>	 <p>$t_1 \leq t_3$</p>	<p>Strength members $a \leq \frac{t_2}{4} + 3$, however max $\frac{t_1}{2}$</p> <p>Local members (tripping brackets, stays, carlings etc) $a \leq \frac{t_2}{4} + 3$</p>	<p>When $a > \frac{t_1}{2}$ correct in one frame space.</p> <p>When $a > \frac{t_2}{4} + 3$ release and adjust the plate. The plate to be released max $50 \times a$.</p>
<p>Fitting accuracy of longitudinals</p>	<p>Web in T, L and flat bar longitudinals</p>  <p>$t_1 \leq t_2$</p>	<p>$a \leq 4$, however max $0,15 t_1$</p>	<p>When $a > 0,15 t_1$ release and adjust the plate. The plate to be released max $50 \times a$.</p>
<p>Fitting accuracy of longitudinals</p>	<p>Flange in T longitudinals Breadth</p> 	<p>$a < 8$, however max $0,04 b$</p>	<p>When $a > 0,04 b$ release and adjust the plate. The plate to be released max $50 \times a$.</p>
<p>Fitting accuracy of longitudinals</p>	<p>Height</p>  <p>$t_1 \leq t_2$</p>	<p>$a \leq 0,2 t_1$</p>	<p>When $a > 0,2 t_1$ release and adjust the plate. The plate to be released max $20 \times a$.</p>

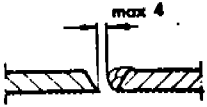
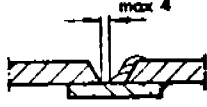

Object	Detail	Max divergences	Corrections
Fitting of corrugated bulkhead	 <p> $t_1 \leq t_3$ A - A $t_1 \leq t_3$ B - B </p>	<p> $a \leq \frac{t_2}{4} + 3$, however max $\frac{t_1}{2}$ </p> <p> a can be greater than t_3 </p>	<p> When $a > \frac{t_1}{2}$ release and adjust the plate. </p> <p> No correction. </p>
3 Overlap brackets	 <p>Bracket</p>	<p> $s \leq 3$ for weld ≥ 4 mm $s \leq 2$ for weld < 4 mm </p>	<ol style="list-style-type: none"> When $3 < s \leq 6$ the stay and/or beam to be turned. Alternatively for weld ≥ 4 the weld throat, to be increased as much as increase of gap opening exceeds 2 mm. When $s > 6$ stay or bracket to be corrected.
4 Gap before manual welding of overlap		<p> $s \leq 3$ for weld ≥ 4 mm $s \leq 2$ for weld < 4 mm </p>	<ol style="list-style-type: none"> When $3 \leq s \leq 5$ the weld throat, to be increased as much as the increase of gap opening exceeds 3 mm. For weld < 4 mm the weld throat, to be increased as much as the increase of gap opening exceeds 2 mm. When $s > 5$ overlapping to be corrected.  <p>max 3 (2)</p>

Object	Detail	Max divergences	Corrections
<p>5 Gap before manual welding of fillet joint, strength members 1)</p>	<p>a. Butt weld</p> 	<p>$s \leq 3$ for weld ≥ 4 mm $s \leq 2$ for weld < 4 mm</p>	<p>1. When $3 < s \leq 5$ the weld throat to be increased as much as the increase of gap opening exceeds 3 mm. For weld < 4 mm the weld throat to be increased as much as the increase of gap opening exceeds 2 mm.</p> <p>2. When $5 < s \leq 10$ chamfer 45° and build up by welding.</p>  <p>3. When $s \geq 10$ chamfer 25° and weld against flat bar. After welding chamfered side remove flat bar and complete by root welding. Alternatively the flat bar can be welded all around.</p>  <p>Alternatively, new plate to be inserted, min 300 mm breadth. General guidance when inserting a new plate, see page 20.</p> 
	<p>b. Single V butt weld</p> 	<p>$s \leq 3$</p>	<p>When $s > 3$ some corrections as per clause 2 and 3 for butt weld above.</p>

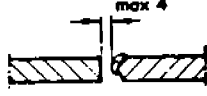
1) Corrections for other members ex. deckhouses, bulkheads etc. should be discussed in every special case.

Object	Detail	Max divergences	Corrections
5 (continuation)	c. Double bevel butt 	$s \leq 4$	<ol style="list-style-type: none"> When $4 < s \leq 10$ built up by welding to max 4 mm gap opening.  When $s > 10$ build up by welding against flat bar. After welding remove flat bar and complete welding.  <p>Alternatively new plate to be inserted, min 300 mm breadth. General guidance when inserting a new plate see page 20.</p> 
6 Gap before manual welding of square butt joints	Square butt joint 	$s \leq 3$	<ol style="list-style-type: none"> When $3 < s \leq 10$ chamfer 45° and build up by welding. Welded surface to be ground.  When $s > 10$ build up by welding against flat bar until opening ≤ 3. Whereupon flat bar is to be removed and the welded surface to be ground. Alternatively the flat bar can be welded all around.  <p>Alternatively new plate to be inserted, min 300 mm breadth. General guidance when inserting a new plate, see page 20.</p> 

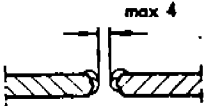
Object	Detail	Max divergences	Corrections
<p>7 Gap before manual welding of single V-butt joint</p>	<p>V-butt joint General</p> 	<p>$s \leq 4$</p>	<p>1. When $4 < s \leq 20$ build up by welding until opening ≤ 4. Welded surface to be ground.</p>  <p>When $s > 20$ build up by welding against flat bar until opening ≤ 4. Whereupon flat bar is to be removed and the welded surface to be ground. Alternatively the flat bar can be welded all around.</p>  <p>Alternatively new plate to be inserted, min 300 mm breadth. General guidance when inserting a new plate, see page 20.</p> 
<p>8 Gap before manual welding of Double bevel butts</p>	<p>Double bevel butts</p> 	<p>$s \leq 4$</p>	<p>1. When $4 < s \leq 20$ build up by welding until opening ≤ 4. Welded surface to be ground.</p>  <p>2. When $s > 20$ new plate to be inserted, min 300 mm breadth. General guidance when inserting a new plate, see page 20.</p> 

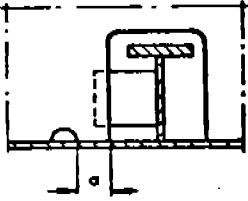
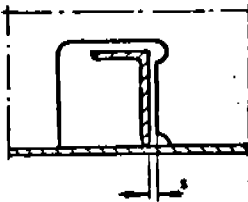
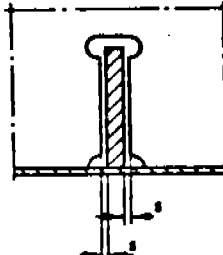
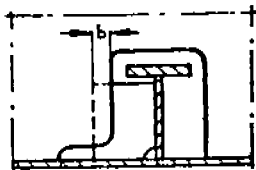
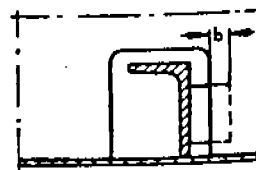
Object	Detail	Max divergences	Corrections
<p>9 Gap before manual welding of double V-butt joints</p>	<p>Double V-butt joints</p> 	<p>$s \leq 4$</p>	<p>1. When $4 < s \leq 20$ build up by welding until opening ≤ 4. Welded surface to be ground.</p>  <p>max 4</p> <p>2. When $s \geq 20$ new plate to be inserted, min 300 mm breadth. General guidance when inserting a new plate, see page 20.</p>  <p>min 300</p>
<p>10 Misalignment of Butt joint</p>		<p>a. Misalignment of Butt joint in deck, shell, tanktop etc within 0,4 of the length of the ship</p> <p>$a \leq 0,2 \times t_1$</p> <p>b. Misalignment of Butt joint in other members</p> <p>$a \leq \frac{1}{3} \times t_1$</p>	<p>When $a > 0,2 \times t_1$ release and adjust the plate.</p> <p>When $a > \frac{1}{3} \times t_1$ release and adjust the plate.</p>
<p>11 Hollow for longitudinals and stay passages</p>	<p>Placing of notch</p>  <p>Gap</p>  	<p>$a \geq 75$</p> <p>$s \leq 3$ for weld ≥ 4 mm $s \leq 2$ for weld ≤ 4 mm</p>	<p>When $a < 75$ web plate to be cut between notch and hollow as per fig. Staying clips to be welded to the shell plating as per fig.</p>  <p>$20 \leq b \leq 60$</p> <p>1. When $3 \leq s \leq 5$ weld throat to be increased as much as increase of gap opening exceeds 3 mm. For weld ≤ 4 mm weld throat to be increased as much as increase of gap opening exceeds 2 mm.</p> <p>2. When $5 \leq s \leq 10$ nib to be chamfered and built up by welding as for gap opening, see point 5.</p> <p>3. When $s > 10$ burn off nib and insert clips with the same height as the nib.</p>  <p>$20 \leq b \leq 60$</p>

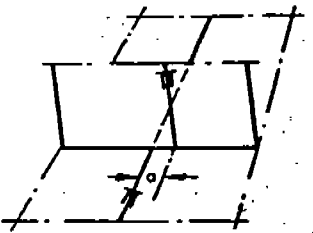
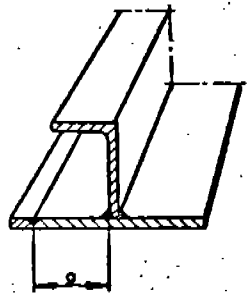
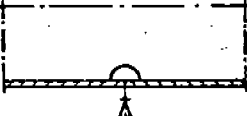
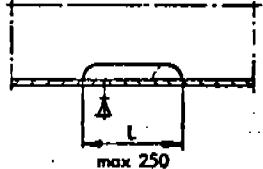
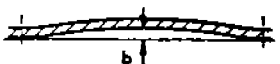
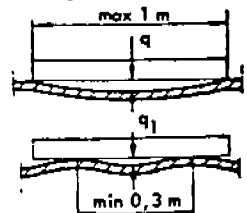
Object	Detail	Max divergences	Corrections
<p>12 Distance between welds</p>	<p>a. Distance between two butt welds</p>  <p>b. Distance between butt weld and fillet weld</p> 	<p>Dimension a free choice</p> <p>Dimension a free choice</p>	<p>If fillet weld will come over the butt weld, the butt weld has to be grounded.</p>
<p>13 Notch over weld in for and after peak</p>			<p>When $L \geq 250$ mm Insert a nab. Alternatively burn a new notch.</p>
<p>14 Deformation of plate</p>	 <ol style="list-style-type: none"> 1. Covered part of poop deck and superstructure decks. 2. Covered parts of deck house bulkheads. 3. Uncovered parts of deck house bulkheads. 4. Uncovered parts of decks in deck house. 5. Other plate in hull such as in shell plating, upper deck, forecastle deck, double bottom, bulkheads, webs, stringers, brackets etc. 	<p>$q \leq 15$</p> <p>$q \leq 15$</p> <p>$q \leq 10$</p> <p>$q \leq 8$</p>	<p>When $q > 15$ plate to be aligned.</p> <p>When $q > 15$ plate to be aligned.</p> <p>When $q > 10$ plate to be aligned.</p> <p>When $q > 8$ plate to be aligned.</p> <p>Are normally aligned.</p> <p>Determining as per SIS 21 11 12. When determining deviation from planeness a straight, 1 metre long rule to be placed on plate and largest distance q from rule to plate are to be determined. Rule should rest on the plate at two points with at least 0,3m distance from each other. Value of q_1 to be converted, where applicable, into a value q corresponding to 1 metre of measuring length.</p> 

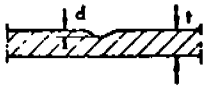
Object	Detail	Max divergences	Corrections
<p>15 Surface defects in plate</p>	 <p>A. Soft round. B. Sharp buckles and/or surface flaws in plate.</p>	<p>$d \leq 0,07 t$, but maximum 3 mm.</p>	<p>When $d > 0,07 t$ or > 3 mm corrections as per point 2 below.</p> <ol style="list-style-type: none"> 1. When $d \leq 0,07 t$, but maximum 3 mm, defects to be ground off. 2. When $d > 0,07 t$ defects to be ground off, but not deeper than 0,2 t. After grinding cavity to be welded with 1,5 mm over full measure after which the weld has to be ground off so the surface becomes even.

Object	Location	Detail	Corrections
16 Handling of temporarily fitted pieces ¹⁾	Tanks and holds	Lift fittings Fittings for staging Clips welded on one side Clips welded on both sides	To be cut 15 mm from the plate surface. Section surface to be ground free from burr. Alternatively clips may remain if welded all around. To be left. To be removed. Surface to be ground. To be removed. Surface defects if any to be repaired. See point 15. Alternatively clips may remain if welded all around.
	In engine- and pumproom	Lift fittings Fittings for staging Clips welded on one side Clips welded on both sides	To be cut 15 mm from the plate surface. Section surface to be ground free from burr. To be removed if unsuitably placed. To be removed. The surface to be ground. To be removed. Surface defects if any to be repaired. See point 15. Alternatively clips may remain if welded all around.
	In dry spaces and staff spaces without ceiling	Lift fittings Fittings for staging Clips welded on one side Clips welded on both sides	To be cut 15 mm from the plate surface. Section surface to be ground free from burr. To be removed. Surface defects if any to be repaired. See point 15. To be removed. The surface to be ground. To be removed. Surface defects if any to be repaired. See point 15.
	Behind ceiling	Lift fittings Fittings for staging Clips welded on one side Clips welded on both sides	To be cut 15 mm from the plate surface. To be cut 15 mm from the plate surface. To be removed. To be removed. Surface defects if any to be repaired. See point 15.

1) Stated corrections are valid if the details do not form obstacles at passages or if there are no other reason for the removing.

Allmänna anvisningar för infällningar

Allmänt

Som komplement till åtgärder "Alternativt insätts ny plåt" gäller följande för påkända förband.

Mindre påkända förband ex däckshus, mellanskott etc behandlas från fall till fall.

Infällning av plåt

Längd- och tvärfällning av plåt utförs enligt fig 1 och infällning vid lokalt fel utförs enligt fig 2.

Beroende på var i fartyget infällningen sker beaktas om valsriktningen för den infällda plåten bör vara samma som närliggande plåt.

General directions for inserts

General

As a complement for the "Alternatively new plate is inserted", the following is valid for strength members.

Other, than strength members, for instance deck houses, intermediate bulkheads, are treated from case to case.

Inserting plates

Longitudinal and transversal inserts to be made according to fig 1 and inserts at local defects to be made according to fig 2.

Depending on where in the ship the inserts are made, it should be observed that the rolling direction of the inserted plate is the same as for the adjacent plates.

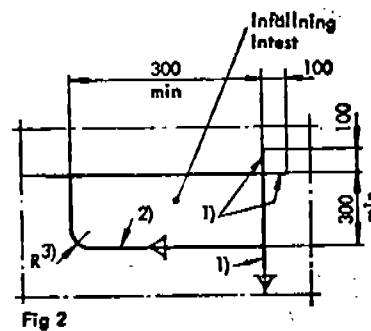
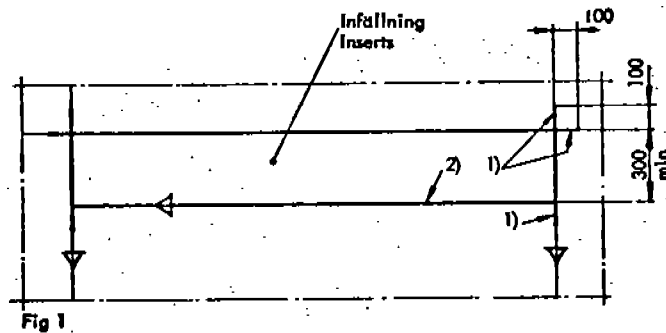

Infällning av profiler o dyl.
Se fig 3.

Inserts of profiles etc.
See fig 3.

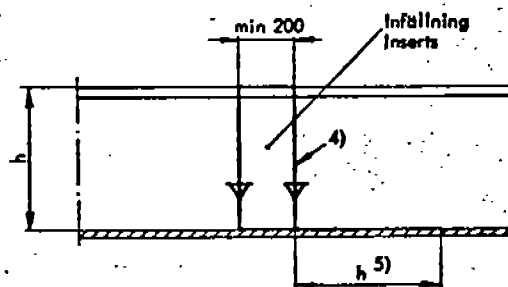

- 1) Hörfogor mot insättningen uppbränns min 100 mm.
- 2) Skarv mot den plåt som skarvas svetsas först.
- 3) $R = 5 \times$ plåttjockleken. Dock min 50 mm.
- 4) Skarvsvets mot uppbränningen svetsas först.
- 5) Profilen uppbränns, motsvarande profilens höjd på en sida av infällningen.

- 1) Corner joints towards the insert to be released min 100 mm.
- 2) Joint towards the plate being joined, to be welded first.
- 3) $R = 5 \times$ plate thickness. Min 75 mm however.
- 4) Joint towards the release to be welded first.
- 5) The profile to be released, corresponding to the height of the profile on one side of the insert.

Igenkänning av hål utföres enligt fig 4, 5 o 6. Hål enligt fig 4 o 6 skall efter nästning, ha sveitsföjd som pilar vid A och B.

Inserts of holes to be made according to fig 4, 5 and 6. After tack welding, holes according to fig 4 should have weld sequence as indicated by arrows at A and B.

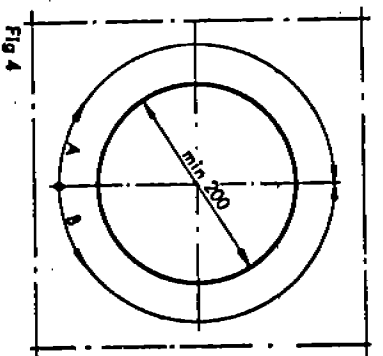

Fig 4

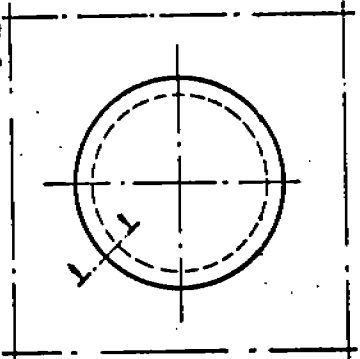

Fig 5

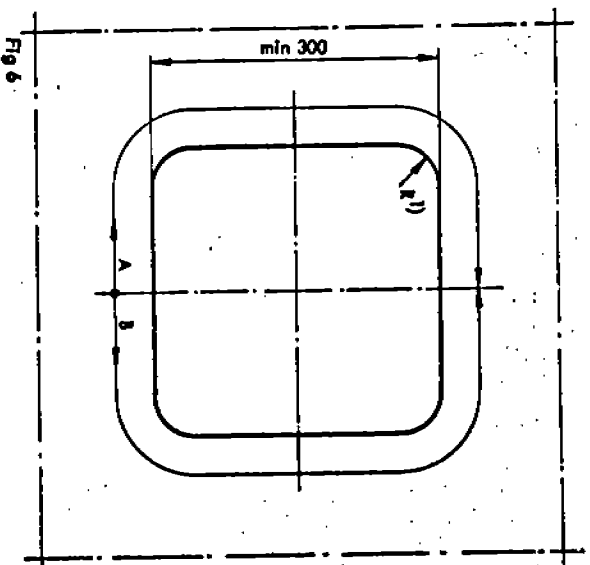
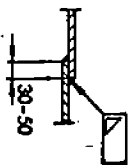

Fig 6

1) R = 5 x plårtjockleken. Dock min 75 mm.

1) R = 5 x plate thickness. Min 75 mm however.

APPENDIX 9.3.4

TRANSLATION
of
CHAPTER IX, ALIGNMENT AND FINISHING
BACKGROUND DOCUMENT 8-3
JAPANESE SHIPBUILDING QUALITY STANDARDS, 1975

Translated by Isao Takeuchi, Manager
New York Office of Nippon Kaiji Kyokai

July 1976

JAPANESE SHIPBUILDING QUALITY STANDARDS (J.S.Q.S.)

Chapter IX Alignment and Finishing

This chapter provides standards for the following:

- A. Minimum distance between welds
- B. Normal root openings
- C. Fitting accuracy
- D. Treatment of staging sockets
- E. Treatment of lifting eye pieces
- F. Closing of holes
- G. Removal of temporary welds
- H. Repairs of under-cuts of temporary welds

The accuracy of fitting at the final assembly is an accumulation of accuracies at all previous construction stages. A high degree of accuracy at early stages (especially at cutting and sub-assembly stages) results in high accuracy at the final assembly stages. However, it is not practical, nor is it economical, to require excessively tight standards of accuracy. The standards should be decided from the view points of whether or not the inaccuracy degrades the ship's quality - strength and appearance, and whether or not the inaccuracy obstructs the subsequent construction stages.

Therefore, some defects such as misalignment, oversize/undersize layout errors, etc., are inevitable at the final assembly. The standards in this chapter provide allowable limits and methods of repair for deviations which exceed the limits.

IX - A Minimum distance between welds

Standards for the minimum distance between welds are beyond the scope of J.S.Q.S. since this is a matter of design. In fact, many shipyards specify these distances in their "Design Standards".

The reason why these standards are included in J.S.Q.S. is that mold loft engineers and application plan sections may need these guidelines in case no details of designs are given and they have to decide the details themselves.

Therefore, the "Design Standards" should first be referred to and if no guidance is given, the standards provided here should be used as a guide.

IX - B Normal clearance between welded members

Standards for normal clearances between welded members are also usually provided in "Design Standards". They are included in the J.S.Q.S. from the viewpoints of both design and workmanship.

(Remarks on page 21)

Remark for Minimum distance between welds:

These standards should be referred to when no details are indicated in the principal plans, and Mold Loft or the Plan Application Section has to decide the detail construction.

Tolerance limits show the figures to be measured after completion.

Remarks for Normal clearance between members

Where there is difference in the thicknesses of plates, a stiffener to be fitted to these plates should be welded as shown in Fig. 9.1a.

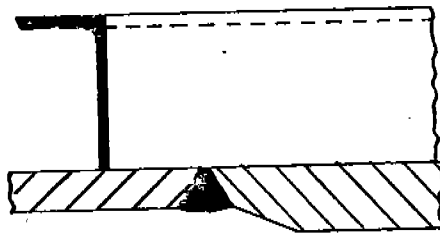

Figure 9.1a Standard Design

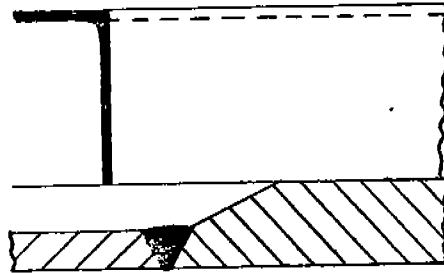

Figure 9.1b Alternate Design

If the clearance is 3 mm or less, no adjustment of stiffener or plate is required.

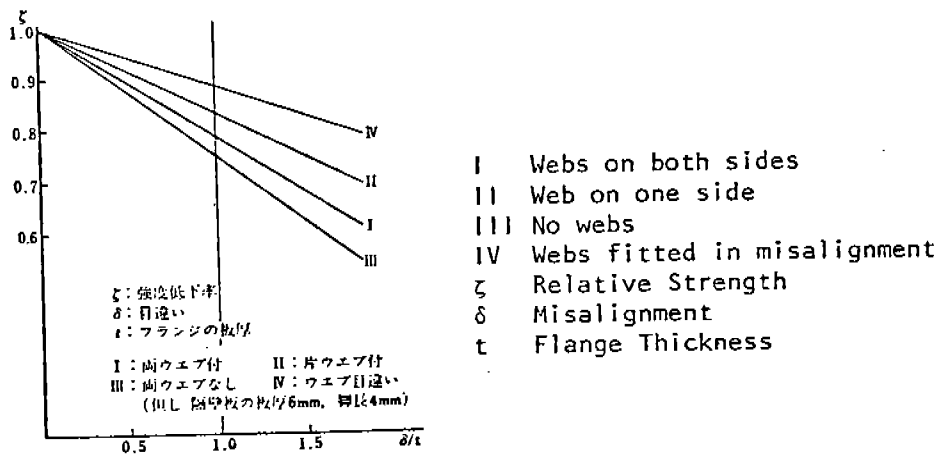

Figure 9.2

Ordinate: Strength of misaligned specimen/Strength of aligned specimen
 Abscissa: Misalignment/Flange thickness

If the construction as shown in Fig. 9.1a is not practical, the construction shown in Fig. 9.1b may be adopted. In this case, if the difference in thickness is 3 mm or less, the stiffener may be welded without any adjustment.

IX - C Fitting Accuracy

IX - C-1 Misalignment of fillet welds

Dr. Fujita and his group performed an experiment to determine the correlation between the amount of misalignment and the static and fatigue strength of the joint. Fig. 9.2 shows the results of this experiment.

We decided that the tolerance limits for misalignment should be $1/3 t$. of the thinner plate for important strength members, and $1/2 t$. for non-strength members. (t . = thickness)

It can be seen from Fig. 9.2 that $1/2 t$. misalignment decreases the strength by 12%, and $1/3 t$. misalignment decreases it by 8%.

These strength decreases can be recovered by increasing the leg length of the fillet weld. Fig. 9.4 shows the strength increase by increasing the leg length of fillet weld.

In choosing the tolerance limits, we used the results of a field survey on the amount of misalignment. The tolerance limits chosen are appropriate from the viewpoint of Quality Control.

IX - C-2 Misalignment of beam and frame

(Figure and Remark on page 22)

If the clearance "a" is 5 mm or less, the beam and the frame can be adjusted to a closer position without disconnecting the frame from the shell

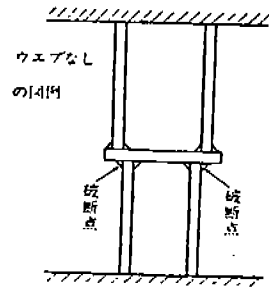

Fillet weld leg length = 4 mm
 Flange thickness = 6 mm
 Breaks indicated by arrows

Figure 9.3 Example of Case III specimen

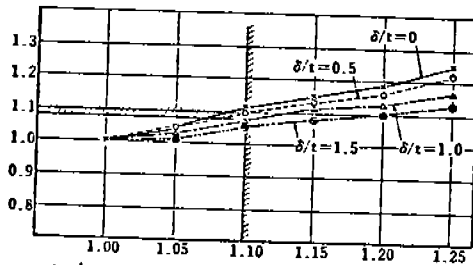

l = original weld leg length
 l_B = increased weld leg length

Ordinate: Relative Strength
 Abscissa: Ratio of leg lengths l_B/l

Figure 9.4

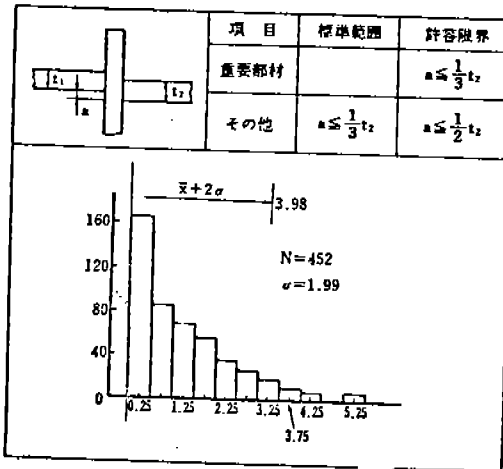

Figure 9.5

	Standard Range	Tolerance Limit
Strength Members	----	$a \leq \frac{1}{3} t_2$
Others	$a \leq \frac{1}{3} t_2$	$a \leq \frac{1}{2} t_2$

$t_1 > t_2$

plating. We established the tolerance to be 5 mm.

IX - C-3 Allowable root openings

IX - C-3-a Fillet Welds

The experiments conducted by the Committee indicated that a root opening of up to 3 mm causes no harmful effects on the weld but it contributes to deeper penetration and consequently it increases the breaking strength of the welding. See Fig. 9.8.

A root opening bigger than 3 mm, however, reduces the strength and also causes pits and undercuts.

We decided that the tolerance should be 3 mm. For gravity-feed welds, the tolerance should be 2 mm because openings in excess of 2 mm cause undercuts.

Corrective action recommended for openings bigger than 3 mm:

1. For openings over 3mm and not more than 5mm;
 - Increase leg length.
2. For openings over 5mm and not more than 16mm or the thickness of the plate, whichever is smaller;
 - Bevel and weld with a backing bar. (The backing bar is to be removed after the welding and the opposite side is to be welded.)
 - or - Insert a filler bar.

Committee SR 127 is investigating the best method of correction.

These standards should be reviewed after the conclusion of SR 127.

3. For openings over the size defined in 2.
 - Partially renew the member.
 - or - Insert a filler bar. (Allowed only in cases where partial renewal is not appropriate)

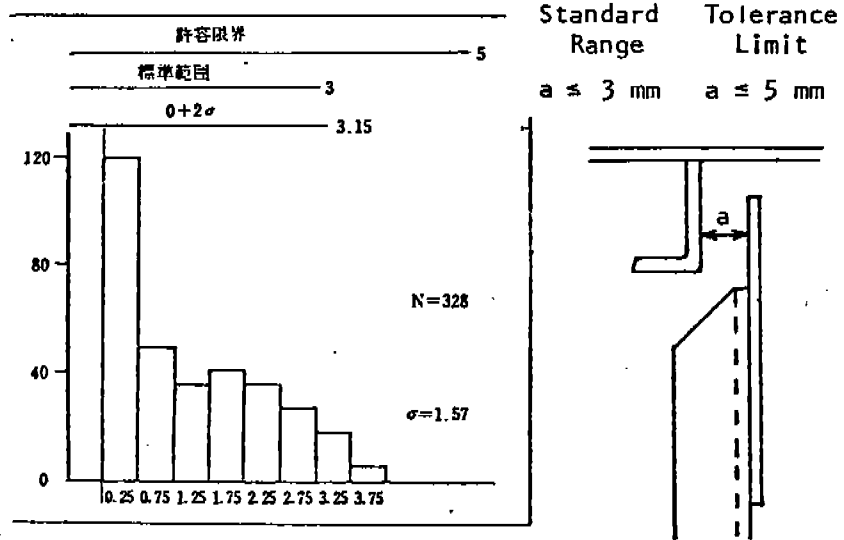

Figure 9.6

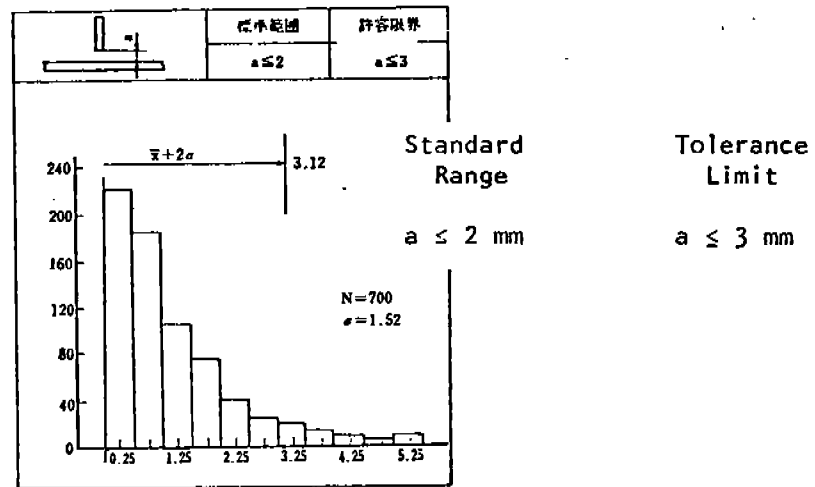
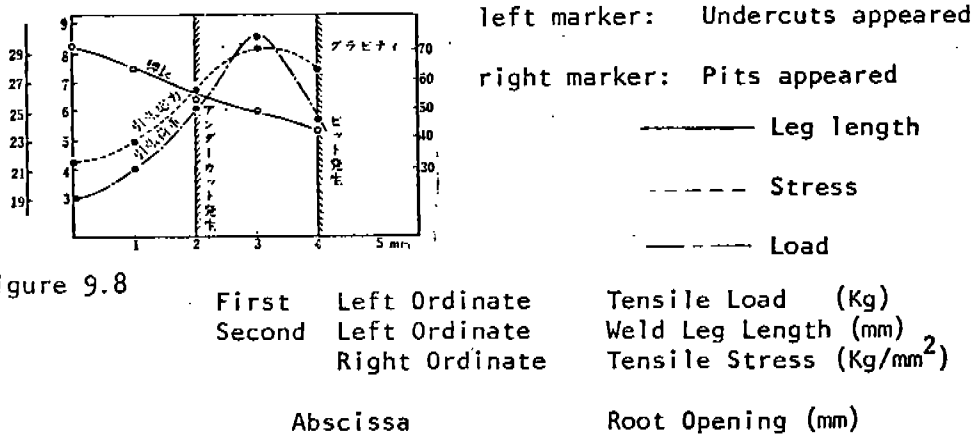

Figure 9.7



IX - C-3-b Butt Welds (Manual welds)

These standards should be applied to ordinary manual welds. For special manual welds such as the "one sided manual weld," each individual shipyard will provide some standards in the "welding manual" or "welding procedure" prepared for that specific weld.

A small root opening (0 to 2 mm) causes an insufficient penetration which requires deeper back gouging and consequently causes greater angular distortion. Thus, a small root opening impedes efficient production, but it does not harm the strength of the weld.

A large root opening, over 5 mm, makes welding impossible.

We decided that the tolerance limit should be 5 mm.

Recommended corrective action for the openings larger than 5 mm:

1. For openings over 5 mm and not more than 16mm, or the thickness of the plate, whichever is smaller;
 - Attach a backing bar, weld, remove backing bar, back-gouge and reweld. This backing bar method is adopted as a result of a report prepared by Yoshida's group which states that a backing bar is very effective in preventing increases of contracting stress. Excessively large openings ruin the appearance of the bead, and cause defects in the weld. We provided the upper limit 16mm or thickness of the plate, whichever is smaller.
 2. For openings over the size defined in 1.
 - Partly renew the plate edge.
- or Make a proper edge by welding. (This build-up or cladding method may be adopted when the opening is 25mm or less.)

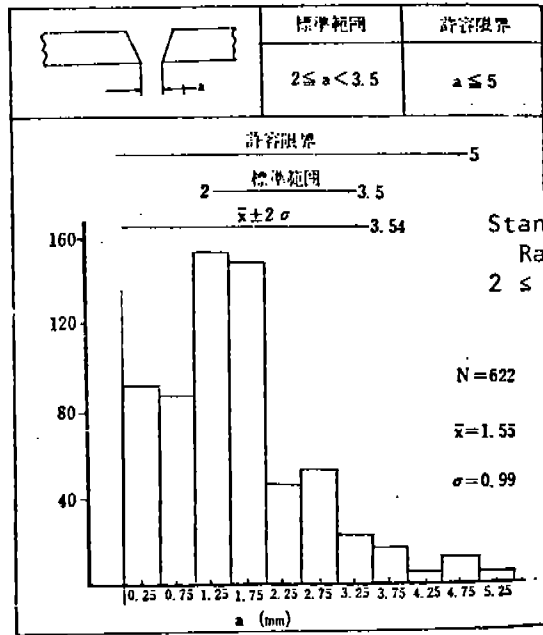

Figure 9.9

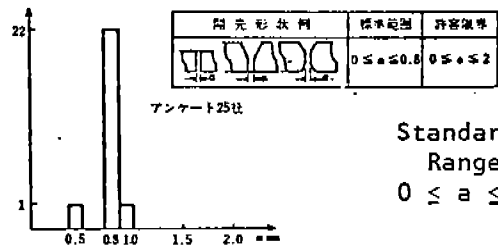

Figure 9.10

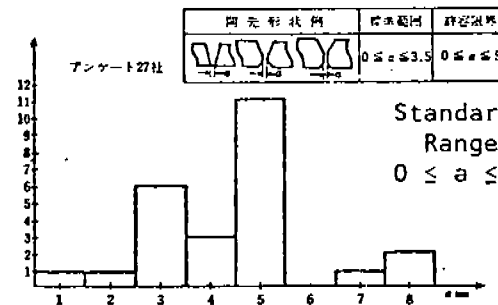

Figure 9.11

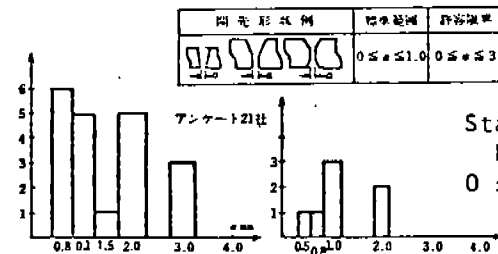
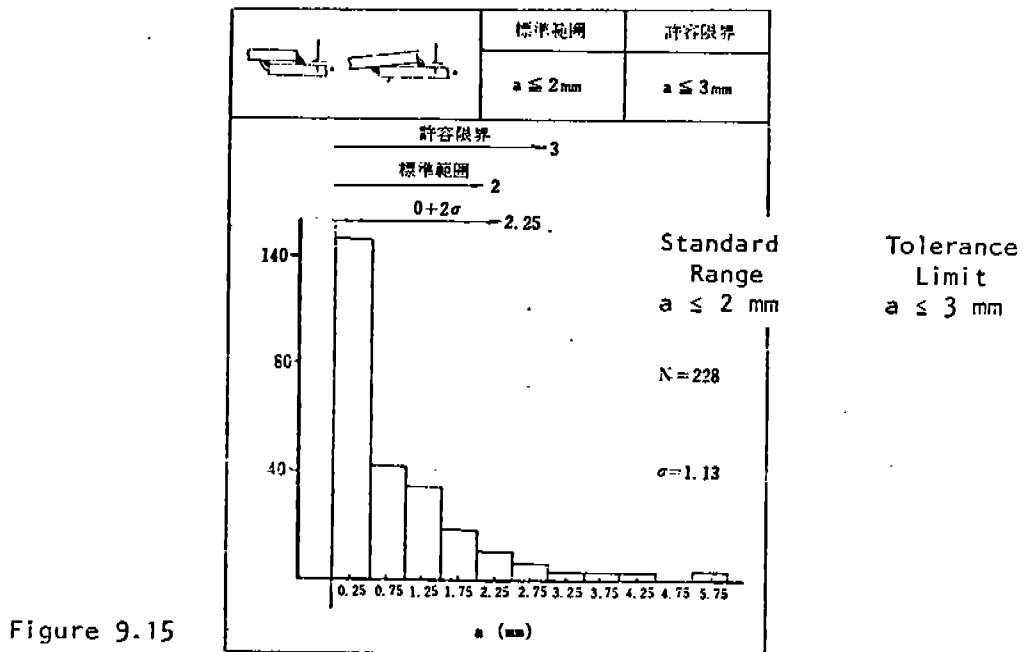
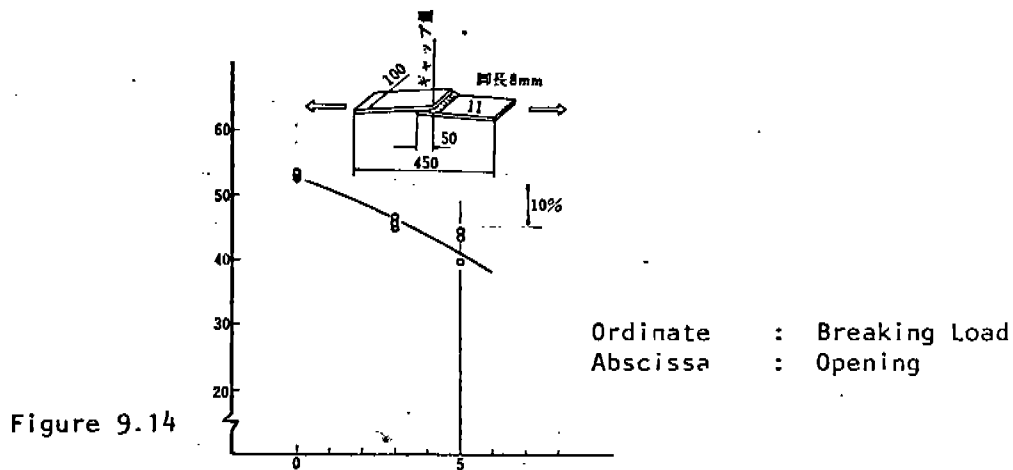
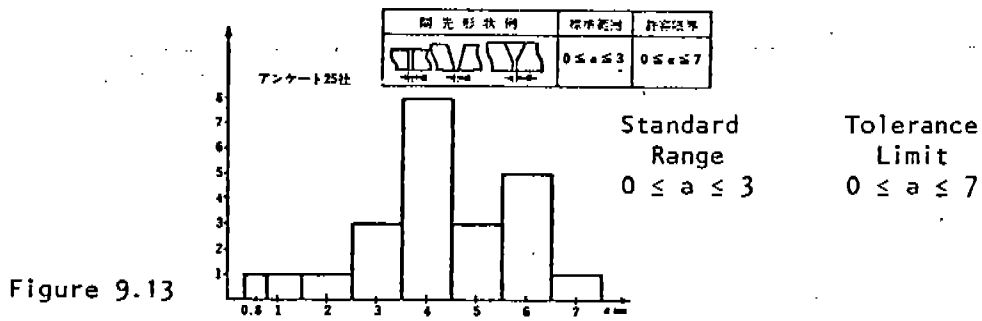

Figure 9.12



IX - C-3-c Butt Welds (Automatic Welds)

There are many kinds and types of automatic welding and the proper size of root openings should be decided according to the manual for the specific welding.

However, it is desirable to set up some common standards even though they do not cover all the types of welding. We collected the welding standards which are used by all the member shipyards. We compared them and found that we can set up common standards for the following welding types:

- Both sides submerged arc welding
- Submerged arc welding with manual or CO₂ welding
- One side submerged arc welding with copper flux backing or flux backing
- One side submerged arc welding with asbestos fiber backing.

Regarding welding methods other than the above, such as electroslag welding, electro gas welding, or consumed nozzle shield gas welding, we decided that it is not appropriate to set up common standards.

In the standards, "Standard ranges" are decided as values that a shipyard will adopt as a guide for quality control. "Tolerance limits" are decided as such values that welding is possible without renewal of the edge of the plates.

1. Both side submerged arc welding

The tolerance limit was decided according to the experience of the member shipyards that openings of 2mm sometimes are found at the I shape intersection of thin plates and special shape bars.

2. Submerged arc welding with manual or CO₂ welding

As the first layer of this welding is performed by manual or CO₂ welding, we adopted the same standards as for the manual weld.

3. One side submerged arc welding with copper flux or flux backing

No remarks

4. One side submerged arc welding with asbestos fiber packing

No remarks

IX - C-3-d Lap Welds

Lap welds are rarely used today. No useful information is available. We conducted simple tensile tests and obtained a correlation between the openings and the breaking loads. The tolerance limits were based on this experiment result.

Fig. 9.14 shows the result of the test. 3mm openings cause 10% decrease of strength. We decided the tolerance limit should be 3mm.

As to the correction of the openings over 3mm, we think it appropriate to increase leg length if the opening is not bigger than 5mm. If it is over 5mm, the member(s) are to be disconnected, adjusted and refitted.

IX - C-4 Misalignment of Butt Welds

The Committee SR 95 performed an experiment to find the effect of misalignment on fatigue strength of butt welds. Figure 9.16 shows the result of the experiment for high tensile steel (HT50). Figure 9.17 shows the same for mild steel.

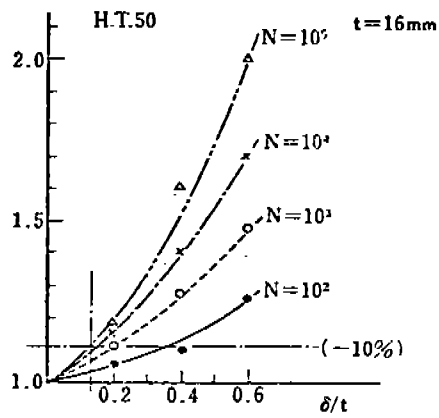

Figure 9.16

Ordinate:

Fatigue Strength, no misalignment
Fatigue Strength, with misalignment

Abscissa:

Relative misalignment

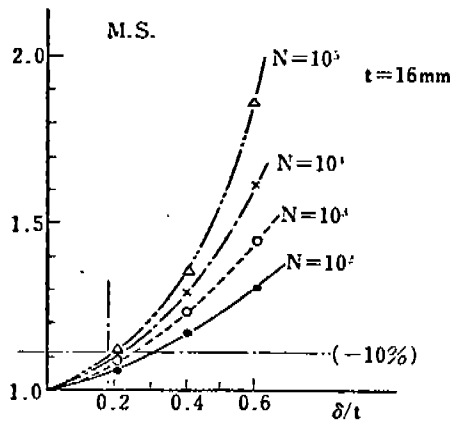

Figure 9.17

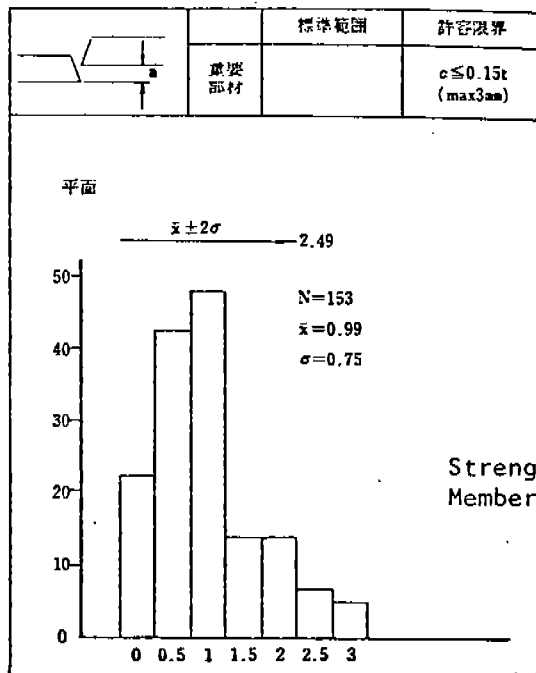

Figure 9.18

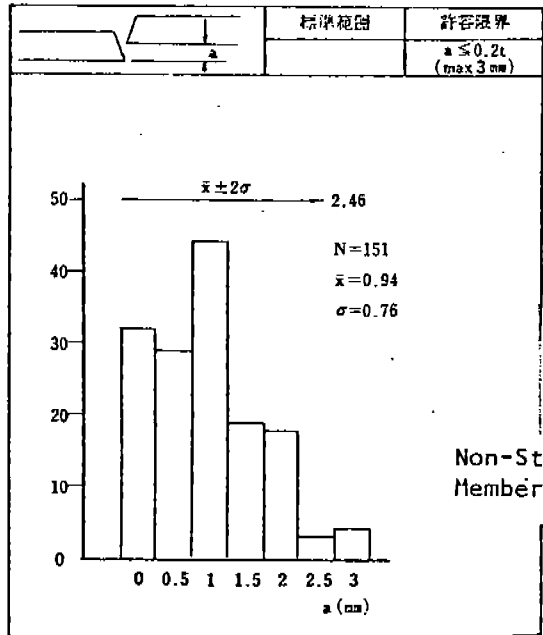

Figure 9.19



Figure 9.20 Spigot-patch-method

Comparing both figures, we see that the high-tensile steel is more sensitive than the mild steel. 10% decrease of fatigue strength (at $N=10^5$) is caused by 0.15 t. misalignment in the high-tensile steel, and by 0.2 t. misalignment in the mild steel (t. = thickness).

Considering the possibility of using high-tensile steel for the important members, the tolerance limits were set as 0.15 t. for strength members and 0.20 t. for non-strength members.

Further, from the viewpoints of appearance and workmanship, we decided that the above tolerances should not be bigger than 3 mm.

IX - D

IX - E Treatment of temporary pieces such as staging sockets and lifting eye plates

The treatment of temporary pieces has been decided by consultation with the owners' supervisors and the classification societies' surveyors. To make a decision, the kind of ship and locations of the pieces are taken into consideration. We referred to those discussions when we decided on the standards.

The table on page 24 should read as follows:

Divisions	Location of the pieces which should be removed	
	Staging Sockets	Lifting Eye Pieces
In Tanks	Need not be removed	On passages
In Engine Room	On passages At places where good appearance is required	Same as staging sockets
In Holds	At lower section of holds On hatch coamings	All pieces except those on back surface of decks
Exposed Parts	All the pieces	All the pieces

IX - F Closing of holes

Dr. Kihara's group investigated the correlation between residual stress due to a butt weld to close a hole and diameter of the hole. They reported that the residual stress is the greatest where the diameter of the hole is 80mm - 100mm. Where the hole is smaller than 80mm in diameter, the residual stress decreased but a welder has difficulty making a good weld.

We decided that holes bigger than 200mm in diameter may be closed by butt weld: holes smaller than 200mm should be enlarged to 200mm and closed by butt weld.

The spigot-patch-method is effective for obtaining good welds and lower residual stresses, when closing small holes. We know this from our experience. We adopted this method to close a small hole which can not be enlarged.

Closing by lap plates may be applied only to unimportant members.

IX - G Removal of temporary welds

IX - G-1 Places where good appearance is required

Exposed shell plating, deck plating and superstructure walls are required to have good appearance.

All the temporary welds are to be chipped off.

IX - G-2 Places where good appearance is not required

Structural members in tanks and other structural members that are covered by ceiling, deck composition and some other covering, are not required to have good appearance.

All the temporary welds need not be removed. But some conspicuous welds may require removal.

IX - H Repair of under-cuts of temporary welds

Such smaller under-cuts as 1mm deep and 10mm long need not be repaired. Beyond that limit, the under-cut should be welded and then chipped flush. Those standards should be applied to places where good appearance is required.

Under-cuts at places where good appearance is not required, are usually not repaired. Only serious undercuts should be welded. No chipping is required.

METRIC CONVERSION FACTORS

Approximate Conversions from Metric Measures

Symbol	When You Know	Multiply by	To Find	Symbol
mm	millimeters	0.04	inches	in
cm	centimeters	0.4	inches	in
m	meters	3.3	feet	ft
m	meters	1.1	yards	yd
km	kilometers	0.6	miles	mi
mm ²	square millimeters	0.16	square inches	sq in
m ²	square meters	1.2	square yards	sq yd
m ²	square meters	0.4	square meters	sq m
km ²	square kilometers (10,000 m ²)	2.5	acres	ac
g	grams	0.035	ounces	oz
kg	kilograms	2.2	pounds	lb
t	tonnes (1000 kg)	1.1	short tons	sh ton
ml	milliliters	0.03	fluid ounces	fl oz
l	liters	2.1	pints	pt
l	liters	1.06	quarts	qt
l	liters	0.28	gallons	gal
m ³	cubic meters	35	cubic feet	ft ³
m ³	cubic meters	1.3	cubic yards	yd ³
TEMPERATURE (exact)				
°C	Celsius (temperature add 27)		Fahrenheit (temperature)	°F
°F	Fahrenheit (temperature subtract 27)		Celsius (temperature)	°C

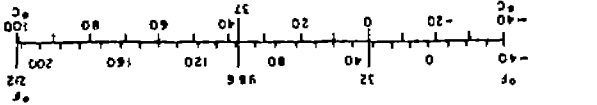

Approximate Conversions to Metric Measures

Symbol	When You Know	Multiply by	To Find	Symbol
in	inches	2.5	centimeters	cm
ft	feet	30	centimeters	cm
yd	yards	0.9	meters	m
mi	miles	1.6	kilometers	km
sq in	square inches	6.5	square centimeters	cm ²
sq ft	square feet	0.09	square meters	m ²
sq yd	square yards	0.8	square meters	m ²
sq m	square meters	2.6	square kilometers	km ²
acres	acres	0.4	hectares	ha
oz	ounces	28	grams	g
lb	pounds	0.45	kilograms	kg
sh ton	short tons (2000 lb)	0.9	tonnes	t
fl oz	fluid ounces	5	milliliters	ml
pt	pints	15	milliliters	ml
qt	quarts	0.95	liters	l
gal	gallons	3.8	liters	l
qt	quarts	0.95	liters	l
pt	pints	0.47	liters	l
cup	cups	0.24	liters	l
sq ft	square feet	0.03	cubic meters	m ³
cu ft	cubic feet	0.76	cubic meters	m ³
TEMPERATURE (exact)				
°C	Celsius (temperature subtracting 27)		Fahrenheit (temperature)	°F
°F	Fahrenheit (temperature subtracting 27)		Celsius (temperature)	°C

1. In 1:54 reading, for other exact conversions to metric units (and tables), see NBS Mon., Publ. 280, Units of Weights and Measures, Price \$2.25, SD Catalog No. C1 3.10 286.



Unclassified

Security Classification

DOCUMENT CONTROL DATA - R & D

Security classification of title, body of abstract and indexes. Annotation must be entered when the overall report is classified

1. ORIGINATING AGENCY (Agency to which)		2a. REPORT SECURITY CLASSIFICATION	
M. Rosenblatt & Son, Inc. 350 Broadway New York, N.Y. 10013		UNCLASSIFIED	
3. REPORT TITLE		2b. GROUP	
SURVEY OF STRUCTURAL TOLERANCES IN THE UNITED STATES COMMERCIAL SHIPBUILDING INDUSTRY			
4. DESCRIPTIVE NOTES (Type of report and inclusive dates)			
Final Report			
5. AUTHOR(S) (First name, middle initial, last name)			
N.S. Basar and R. F. Stanley			
6. REPORT DATE		7a. TOTAL NO. OF PAGES	7b. NO. OF REFS
April, 1978		207	102
8a. CONTRACT OR GRANT NO.		9a. ORIGINATOR'S REPORT NUMBER(S)	
N00024-76-C-4059		SSC-273	
b. PROJECT NO.		9b. OTHER REPORT NO(S) (Any other numbers that may be assigned this report)	
SR-1223			
10. DISTRIBUTION STATEMENT			
This document has been approved for public release and sale, its distribution is unlimited.			
11. SUPPLEMENTARY NOTES		12. SPONSORING MILITARY ACTIVITY	
		Naval Ship Engineering Center	
13. ABSTRACT			
<p>Deviations from ideal structural design of different types of vessels during construction and service are investigated. Selected U.S. commercial shipyards, ship owner/operators, steel mills, and foreign classification societies are surveyed or interviewed with the purpose of documenting major deviations and recurring structural imperfections, and determining the factors leading to these deviations. An effort is also made to determine the extent of deviations from theoretical design and to establish, wherever possible, structural tolerance limits which are most commonly used in U.S. yards and which can therefore be considered representative of U.S. shipbuilding practice. These are compared to published international structural tolerance standards, and recommendations are given for further study.</p>			

4 KEY WORDS	LINK A		LINK B		LINK C	
	ROLE	WT	ROLE	WT	ROLE	WT
Detail Deviation Fabrication Shipbuilding Survey Standards Tolerances						

SHIP RESEARCH COMMITTEE
Maritime Transportation Research Board
National Academy of Sciences-National Research Council

The Ship Research Committee has technical cognizance of the interagency Ship Structure Committee's research program:

- MR. O. H. OAKLEY, Chairman, *Consultant, McLean, Virginia*
MR. M. D. BURKHART, Head, *Marine Science Affairs, Office of Oceanographer of the Navy*
DR. J. N. CORDEA, *Senior Staff Metallurgist, ARMCO Steel Corporation*
MR. D. P. COURTSAL, *Vice President, DRAVO Corporation*
MR. E. S. DILLON, *Consultant, Silver Spring, Maryland*
DEAN D. C. DRUCKER, *College of Engineering, University of Illinois*
MR. W. J. LANE, *Consultant, Baltimore, Maryland*
MR. R. W. RUMKE, *Executive Secretary, Ship Research Committee*

The Ship Materials, Fabrication, and Inspection Advisory Group prepared the project prospectus, evaluated the proposals, provided the liaison technical guidance, and reviewed the project reports with the investigator:

- DR. J. N. CORDEA, Chairman, *Senior Staff Metallurgist, ARMCO Steel Corporation*
MR. J. L. HOWARD, *President, Kvaerner-Moss, Inc., N.Y.*
MR. J. G. KAUFMAN, *Manager, Technical Development, Aluminum Company of America*
MR. T. E. KOSTER, *Naval Architect, AMOCO International Oil Company*
DR. H. I. MCHENRY, *National Bureau of Standards, Boulder, CO*
PROF. P. F. PACKMAN, *Materials Science & Metallurgical Engrg. Dept. Vanderbilt University*
PROF. S. T. ROLFE, *Civil Engineering Dept., University of Kansas*
PROF. G. C. SIH, *Inst. of Fracture & Solid Mechanics, Lehigh University*

SHIP STRUCTURE COMMITTEE PUBLICATIONS

These documents are distributed by the National Technical Information Service, Springfield, Va. 22151. These documents have been announced in the Clearinghouse journal U.S. Government Research & Development Reports (USGRDR) under the indicated AD numbers.

- SSC-258, *A Study to Obtain Verification of Liquid Natural Gas (LNG) Tank Loading Criteria* by R. L. Bass, J. C. Hokanson, and P. A. Cox. 1976. AD-A025716.
- SSC-259, (SL-7-6) - *Verification of the Rigid Vinyl Modeling Technique: The SL-7 Structure* by J. L. Rodd. 1976. AD-A025717.
- SSC-260, *A Survey of Fastening Techniques for Shipbuilding* by N. Yutani and T. L. Reynolds. 1976. AD-A031501.
- SSC-261, *Preventing Delayed Cracks in Ship Welds - Part I* by H. W. Mishler. 1976. AD-A031515.
- SSC-262, *Preventing Delayed Cracks in Ship Welds - Part II* by H. W. Mishler. 1976. AD-A031526.
- SSC-263, (SL-7-7) - *Static Structural Calibration of Ship Response Instrumentation System Aboard the Sea-Land McLean* by R. R. Boentgen and J. W. Wheaton. 1976. AD-A031527.
- SSC-264, (SL-7-8) - *First Season Results from Ship Response Instrumentation Aboard the SL-7 Class Containership S.S. Sea-Land McLean in North Atlantic Service* by R. R. Boentgen, R. A. Fain and J. W. Wheaton. 1976. AD-A039752.
- SSC-265, *A Study of Ship Hull Crack Arrestor Systems* by M. Kanninen, E. Mills, G. Hahn, C. Marschall, D. Broek, A. Coyle, K. Masubushi and K. Itoga. 1976. AD-A040942.
- SSC-266, *Review of Ship Structural Details* by R. Glasfeld, D. Jordan, M. Kerr, Jr., and D. Zoller. 1977. AD-A040941.
- SSC-267, *Compressive Strength of Ship Hull Girders - Part III - Theory and Additional Experiments* by H. Becker and A. Colao. 1977. AD-A047115.
- SSC-268, *Environmental Wave Data for Determining Hull Structural Loadings* by D. Hoffman and D. A. Walden. 1977. AD-A047116.
- SSC-269, *Structural Tests of SL-7 Ship Model* by W. C. Webster and H. G. Payer. 1977. AD-A047117.
- SSC-270, *Gross Panel Strength Under Combined Loading* by A. E. Mansour. 1977. AD-A049337.
- SSC-271, *A Correlation Study of SL-7 Containership Loads and Motions - Model Tests and Computer Simulation* by P. Kaplan, T. P. Sargent, and M. Silbert. 1977. AD-A049349.
- SSC-272, *In-Service Performance of Structural Details* by C. R. Jordan and C. S. Cochran. 1978.