

SSC-309

**A RATIONAL BASIS FOR
THE SELECTION OF ICE
STRENGTHENING CRITERIA
FOR SHIPS—VOL. I**

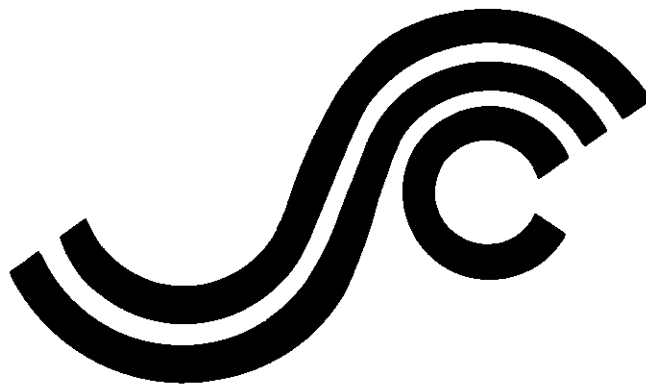

This document has been approved
for public release and sale; its
distribution is unlimited.

SHIP STRUCTURE COMMITTEE

1981

SHIP STRUCTURE COMMITTEE

The SHIP STRUCTURE COMMITTEE is constituted to prosecute a research program to improve the hull structures of ships and other marine structures by an extension of knowledge pertaining to design, materials and methods of construction.

RAAdm Clyde T. Lusk, Jr. (Chairman)
Chief, Office of Merchant Marine
Safety
U. S. Coast Guard Headquarters

Mr. J. Gross
Deputy Assistant Administrator for
Commercial Development
Maritime Administration

Mr. P. M. Palermo
Executive Director
Ship Design & Integration
Directorate
Naval Sea Systems Command

Mr. J. B. Gregory
Chief, Research & Development Staff
of Planning & Assessment
U.S. Geological Survey

Mr. W. N. Hannan
Vice President
American Bureau of Shipping

Mr. Thomas W. Allen
Chief Engineering Officer
Military Sealift Command

LCdr D. B. Anderson, U.S. Coast Guard (Secretary)

SHIP STRUCTURE SUBCOMMITTEE

The SHIP STRUCTURE SUBCOMMITTEE acts for the Ship Structure Committee on technical matters by providing technical coordination for the determination of goals and objectives of the program, and by evaluating and interpreting the results in terms of structural design, construction and operation.

U. S. COAST GUARD

Capt. R. L. Brown
Cdr. J. C. Card
Mr. R. E. Williams
Cdr. J. A. Sanial

MILITARY SEALIFT COMMAND

Mr. Albert Attermeyer
Mr. T. W. Chapman
Mr. A. B. Stavovy
Mr. D. Stein

NAVAL SEA SYSTEMS COMMAND

Mr. R. Chiu
Mr. J. B. O'Brien
Mr. W. C. Sandberg
Lcdr D. W. Whiddon
Mr. T. Nomura (Contracts Admin.)

AMERICAN BUREAU OF SHIPPING

Dr. D. Liu
Mr. I. L. Stern

MARITIME ADMINISTRATION

Mr. N. O. Hammer
Dr. W. M. Maclean
Mr. F. Seibold
Mr. M. Touma

U. S. GEOLOGICAL SURVEY

Mr. R. Giangerelli
Mr. Charles Smith

NATIONAL ACADEMY OF SCIENCES SHIP RESEARCH COMMITTEE

Mr. A. Dudley Haff - Liaison
Mr. R. W. Rumke - Liaison

INTERNATIONAL SHIP STRUCTURES CONGRESS

Mr. S. G. Stiansen - Liaison

SOCIETY OF NAVAL ARCHITECTS & MARINE ENGINEERS

Mr. A. B. Stavovy - Liaison

AMERICAN IRON & STEEL INSTITUTE

Mr. R. H. Sterne - Liaison

WELDING RESEARCH COUNCIL

Mr. K. H. Koopman - Liaison

STATE UNIV. OF NEW YORK MARITIME COLLEGE

Dr. W. R. Porter - Liaison

U. S. COAST GUARD ACADEMY

LCdr R. G. Vorthman - Liaison

U. S. NAVAL ACADEMY

Dr. R. Battacharyya - Liaison

U. S. MERCHANT MARINE ACADEMY

Dr. Chin-Bea Kin - Liaison

Member Agencies:

*United States Coast Guard
Naval Sea Systems Command
Military Sealift Command
Maritime Administration
United States Geological Survey
American Bureau of Shipping*



An Interagency Advisory Committee
Dedicated to Improving the Structure of Ships

Address Correspondence to:

Secretary, Ship Structure Committee
U.S. Coast Guard Headquarters, (G-M/TP 13)
Washington, D.C. 20593

SR-1267

1981

As marine activity in ice covered waters is expected to increase in the foreseeable future, the design of ships to meet the varying conditions will have an expanding role for the naval architect.

The Ship Structure Committee has undertaken a program to acquire the necessary knowledge to permit a rational design for vessels which will be operating in various ice conditions. This first effort in the program surveyed the various classification societies and government regulations in order to discern the similarities and differences of their requirements, and further to recommend a procedure for selecting appropriate ice strengthening criteria. The results of this project are being published in two volumes. Volume I (SSC-309) contains the analytical portion of the work and Volume II (SSC-310) contains the appendices.

A handwritten signature in black ink, appearing to read "Clyde T. Lusk, Jr.", is positioned above the typed name.

Clyde T. Lusk, Jr.
Rear Admiral, U.S. Coast Guard
Chairman, Ship Structure Committee

1. Report No. SSC-309		2. Government Accession No.		3. Recipient's Catalog No.	
4. Title and Subtitle A RATIONAL BASIS FOR THE SELECTION OF ICE STRENGTHENING CRITERIA FOR SHIPS VOLUME I				5. Report Date 15 February 1981	
				6. Performing Organization Code	
7. Author(s) J. L. Coburn, F. W. DeBord, J. B. Montgomery, A. M. Nawwar, K. E. Dane				8. Performing Organization Report No. SR-1267	
9. Performing Organization Name and Address ARCTEC, Incorporated 9104 Red Branch Road Columbia, Maryland 21045				10. Work Unit No. (TRAIS)	
				11. Contract or Grant No. DOT-CG-904937-A	
12. Sponsoring Agency Name and Address U.S. Coast Guard Office of Merchant Marine Safety Washington, D.C. 20593				13. Type of Report and Period Covered Final Report 20 August 1979 - 26 May 1980	
				14. Sponsoring Agency Code G-M	
15. Supplementary Notes SHIP STRUCTURE COMMITTEE PROJECT SR 1267					
16. Abstract A major consideration in the development of marine transportation for ice-covered waters is the knowledge of the strength required for ship's hulls. Several classification societies and various government regulations provide guidelines for strengthening of ice-transiting ships. However, there are inconsistencies among these different guidelines, and ships have suffered hull damage from ice while operating in zones for which they were supposedly strengthened adequately. This report presents the results of a study to develop the basis for rational selection of ice strengthening criteria for vessels. Volume I describes sources and differences between ice strengthening criteria in use by various classification societies, and Government regulations such as Canadian Arctic Pollution Prevention Regulations, and Swedish-Finnish Winter Navigation Board Regulations. A comparison of the different criteria is presented on the basis of a relative weight and relative cost. Effectiveness of the criteria is evaluated on the basis of statistical ice damage data and on a sample of individual ice damage cases. In addition, a comparison of different materials and fabrication techniques used for ice strengthening is presented. Deficiencies in current ice strengthening procedures are identified and a rational procedure for selecting appropriate ice strengthening criteria is presented. In addition, recommendations for research needed to improve current ice strengthening criteria are described. Volume II contains the appendices to the report including maximum and average ice conditions by month, tabular data, and a review of methods for damage analysis.					
17. Key Words Classification Society Rules Ice-Worthy Ships Ice Strengthening Hull Strength Icebreaker Ice Classification			18. Distribution Statement Documentation is available to the U.S. public through the National Technical Information Service, Springfield, Virginia 22161		
19. Security Classif. (of this report) Unclassified		20. Security Classif. (of this page) Unclassified		21. No. of Pages 152	22. Price

METRIC CONVERSION FACTORS

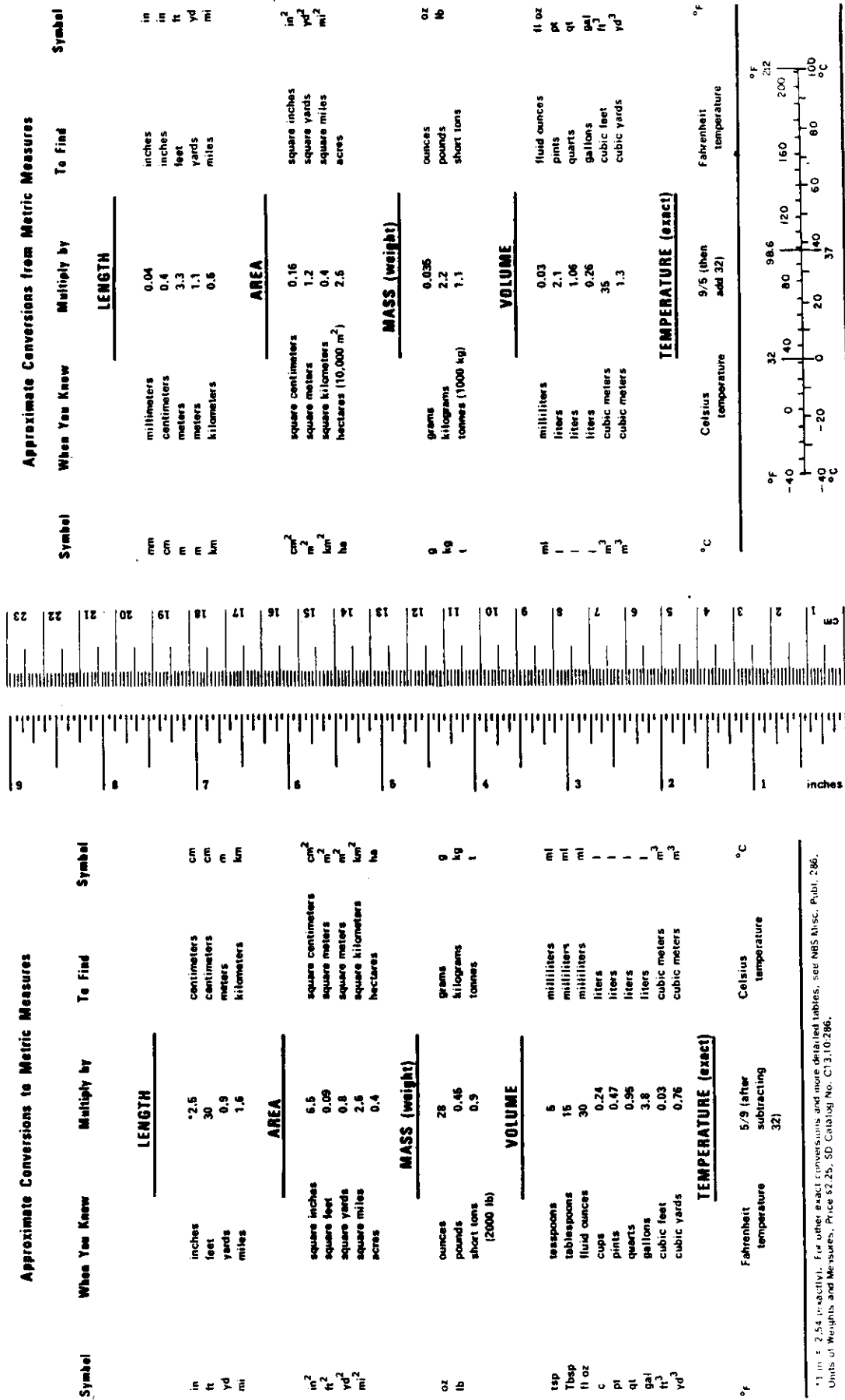

¹ 1 in = 2.54 (exactly). For other exact conversions and more detailed tables, see NBS Misc. Publ. 286, Units of Weights and Measures, Price \$2.25, SD Catalog No. C13.10.286.

FIGURE 3. METRIC CONVERSION FACTORS

CONTENTS

VOLUME I	Page
1. INTRODUCTION	1-1
1.1 Objective	1-1
1.2 Background	1-1
1.3 Approach	1-3
2. PROBLEM DEFINITION	2-1
2.1 Introduction	2-1
2.2 Definition of Load	2-2
2.3 Definition of Structural Response	2-12
2.4 Reliability	2-14
3. ENVIRONMENT	3-1
3.1 Introduction	3-1
3.2 Governing Ice Conditions	3-1
3.3 Sources of Data and Analysis Procedures	3-4
4. MATERIALS	4-1
4.1 Material Requirements for Ice Strengthened Ships	4-1
4.2 Currently Available Steels	4-9
4.3 Existing Criteria for Material Selection	4-12
4.4 Requirements for Additional Information	4-13
5. EXISTING ICE STRENGTHENING CRITERIA	5-1
5.1 General Description of Existing Criteria	5-1
5.2 Methods for Selecting the Level of Ice Strengthening	5-1
5.3 Load Criteria, Rationale, and Structural Design Methods	5-4
5.4 Resulting Scantlings for Three Representative Ships	5-19
5.5 Analysis of the Load-Carrying Capability of Resulting Scantlings	5-27
5.6 Analysis of Equivalence Between Certain Criteria	5-33
5.7 Comparison of Relative Steel Weights and Fabrication Costs	5-36
6. EXPERIENCE OF ICE-CLASSED SHIPS	6-1
6.1 Specific Ice Damage	6-1
6.2 General and Fleet Experience with Ice-Classed Ships	6-1
7. CRITIQUE OF CURRENT CRITERIA	7-1
7.1 General Deficiencies	7-1
7.2 Assumed Distribution of Load for Frame Design	7-2
7.3 Factors and Method Used to Determine Design Load	7-6
7.4 Structural Analysis Methods and Response Criteria	7-6

CONTENTS (Continued)

	Page
8. PROPOSED RATIONAL BASIS FOR SELECTING ICE STRENGTHENING CRITERIA	8-1
8.1 Materials	8-1
8.2 Reliability	8-1
8.3 Loads	8-4
8.4 Response Criteria	8-5
8.5 Summary of Proposed Approach	8-8
9. RECOMMENDATIONS-NEEDED RESEARCH AND DEVELOPMENT	9-1
9.1 R&D Program Summary	9-1
9.2 Full-Scale Tests	9-1
9.3 Refine the Rational Approach	9-3
9.4 Incorporate Response Criteria into the Approach Proposed in Section 8	9-3
9.5 Ice Interaction	9-4
9.6 Generalize the Analytic Model of Ship-Ice Interaction	9-5
10. BIBLIOGRAPHY	10-1
11. APPENDIX - Ice Terms Arranged in Alphabetical Order.	11-1
VOLUME II	
A - Maximum and Average Ice Conditions by Month	A-1
B - Tabular Data.	B-1
C - Review of Methods for Damage	C-1

LIST OF FIGURES

<u>Number</u>	<u>Title</u>	<u>Page</u>
1.1	Projected Offshore Alaska Commercial Development	1-3
2.1	General Effect of Strain-Rate on Ice Strength	2-3
2.2	Bore-Hole Jack Test Results	2-5
2.3	Effect of Ice Thickness and Failure Mode on Maximum Ice Impact Force	2-13
2.4	Effect of Crushing Strength in Crushing-Bending Failure Mode	2-13
2.5	Effect of Impact Speed on Maximum Ice Load	2-13
3.1	Maximum Ice Conditions, April	3-3

LIST OF FIGURES (Continued)

<u>Number</u>	<u>Title</u>	<u>Page</u>
4.1	Summary of DT Test Performance of the ABS Grade A Plates	4-2
4.2	Summary of DT Test Performance of the ABS Grade B Plates	4-2
4.3	Summary of DT Test Performance of Heat Treated (Normalized ABS Grade D Plates and of One As-Rolled ABS Grade D Plate	4-3
4.4	Summary of DT Test Performance of ABS Grade E Plates	4-3
4.5	Summary of DT Test Performance of ABS Grade CS Plates	4-4
4.6	5/8" Parent DT, Press-Notch, AH-32 (Heat 2)	4-4
4.7	Charpy V-Notch Impact Test Curves for ABS-DH Steel	4-5
4.8	EH-32 (Heat 3), 5/8" Parent DT, Press-Notch	4-5
4.9	DT and CVN Test Results for 537A Steel	4-6
4.10	DT and CVN Test Results for A537B Steel	4-6
4.11	DT and CVN Test Results for A537B Steel	4-7
4.12	A678-C (Heat 7), 5/8" Parent DT, Press-Notch	4-7
4.13	DT Test Results for ASTM A-710 Grade A Steel Plates	4-8
5.1	Arctic Pollution Prevention Control Zones	5-5
5.2	Canadian ASPPR Hull Areas for Ice Strengthening	5-9
5.3	ASPPR Rule Ice Pressure vs. Arctic Class of Ship	5-10
5.4	Example of Damage Analysis Conducted by Johansson	5-13
5.5	Comparison of Framing Design Ice Pressures Specified by Johansson with Those Specified by the Finnish-Swedish Ice Class Rules	5-13
5.6	POLAR Class Icebelt Configuration Showing Design Pressures	5-18
5.7	Design Ice Loads for Icebreakers Based on USCG Experience	5-18
5.8	Regression of Full-Scale Ice Load Data From the MACKINAW and LEON FRAZER Tests	5-20
5.9	Assumed Structural Configuration of Three Representative Ships	5-21
5.10	Comparison of Bow Plating Design Pressures for Three Representative Ships	5-21

LIST OF FIGURES (Continued)

<u>Number</u>	<u>Title</u>	<u>Page</u>
5.11	Comparison of Bow Transverse Frame Design Pressures for Three Representative Ships	5-25
5.12	Variation in Plating Design Pressure with Hull Area for POLAR STAR	5-26
5.13	Load-Carrying Capability of POLAR STAR Bow Structure for Various Ice Strengthening Criteria	5-30
5.14	Load-Carrying Capability of MV ARCTIC Bow Structure for Various Ice Strengthening Criteria	5-31
5.15	Load-Carrying Capability of Arctic Tanker Bow Structure for Various Ice Strengthening Criteria	5-32
5.16	Percentage Increases in Steel Weights Above ABS A1 for Ice Strengthened Midbody Panels	5-40
6.1	MV ARCTIC Ice Damage, October 1978	6-2
6.2	Structural Differences Between the EDWIN H. GOTT and the BELLE RIVER	6-6
6.3	Predicted Ice Impact Forces on Hull vs. Distance from F.P. for 12 inch and 6 inch Level Ice	6-7
6.4	Relative Frequency of Ice Damage to Ships with Various Ice Classing	6-9
6.5	Relative Frequency of Ice Damage for Different Types of Ships	6-9
6.6	Histogram Showing Distribution of Damage Incidents According to Ship Tonnage	6-10
6.7	Distribution of Damage Incidents Per Time of the Year	6-11
7.1(a)	General Description of Load Distribution in Johansson's Method	7-3
7.1(b)	Form of Load Distribution Used by Johansson in Final Form	7-3
7.2	Comparison of Section Modulus for MV ARCTIC as Computed by Eqn. 7.2 and in Accordance with Ref. [C-11]	7-5
7.3	Example of Damage Analysis Conducted by Johansson from Ref. [B-16]	7-7
8.1	Proposed Triaxial Strength Factor	8-3
8.2	POLAR STAR Hull (Strain Gage) Response, 1976	8-6
9.1	Recommended Schedule for R&D Program	9-6

LIST OF TABLES

<u>Number</u>	<u>Title</u>	<u>Page</u>
2.1	Selected Class for Ice Load Predictions	2-7
2.2	Model Hull Data Sheet - MV ARCTIC	2-8
2.3	Comparison of Characteristics of MV ARCTIC as Built and Scaled-Up Ship	2-9
2.4	Results	2-11
5.1	Listing of Current Ice Strengthening Criteria	5-2
5.2	Classification Society Regulations Deemed Equivalent to Canadian ASPPR Types	5-3
5.3	Classification Society Ice Classes Identical or Equivalent to Finnish-Swedish Regulations	5-3
5.4	Canadian Restrictions to Navigation by Control Zone and Time of Year	5-6
5.5	Ice Strengthening Criteria Which Specify Scantlings by Increasing Normal Rule Scantlings	5-8
5.6	Ice Pressures Used by the Canadian Arctic Shipping Pollution Prevention Regulations	5-10
5.7	Principal Characteristics of Three Representative Ships	5-20
5.8	American Bureau of Shipping Scantlings for Three Representative Ships	5-22
5.9	Ice Strengthened Bow Plating Thickness for Three Representative Ships	5-28
5.10	Ice Strengthened Bow Transverse Frame Section Moduli for Three Representative Ships	5-29
5.11	Typical Ice Class Cargo Ship Data	5-37
5.12	Equivalent Design Pressures in Various Criteria	5-38
6.1	Powering and Bow Structure Specifications for Ten Great Lakes Vessels	6-4
6.2	Selected Damage Incidents for Ice Classed Ships in Canadian Waters (1970-1978)	6-13

LIST OF TABLES (Continued)

<u>Number</u>	<u>Title</u>	<u>Page</u>
7.1	Ice Pressure, Bow Area	7-2
7.2	Summary of Differences Among Ice Strengthening Criteria	7-8
8.1	Uniaxial Crushing Strength	8-3
9.1	R&D Programs to Improve Ice Strengthening Criteria Breakdown by Objectives	9-1

1. INTRODUCTION

1.1 Objective

The principal objective of the work described by this report is to develop a basis for the rational selection of ice strengthening criteria for vessels. An important secondary objective is to identify areas requiring research and development.

The role and nature of the "rational basis" for the selection of ice strengthening are described as follows: It is understood that it is *not* the position of this project team, nor any other R&D team or investigator, to specify that a ship for this ice service must have plating so many inches thick, or scantlings of thus and so dimensions. Rather, the results should be cast in a format that presents to the regulatory body, the classification society, and the owner, a method to associate a level of confidence with the selection of certain plating and scantlings for a given ice service. In this format, the researcher presents his results, independent of the important, but separate, consideration of risks. The weighing of risks is left to the various sovereign governments, the underwriters, and the owners.

1.2 Background

The need to address the subject of a rational basis for ice strengthening criteria stems from two conditions: the world-wide increase of marine activity in ice-covered areas, particularly, but not restricted to, the Arctic, and the rather wide disparities among the existing criteria for ice strengthening ships. The existing criteria and their differences are analyzed in detail in this report. Marine activity in the Arctic and subarctic areas with sea ice has been spurred by the world-wide petroleum shortage and the presence of major proven and probable reserves. For example, the Prudhoe Bay oil field is the largest outside of Saudi Arabia. At the current production rate of 1.2 million barrels per day, Prudhoe Bay production ranks near the middle of the OPEC nations.

The recent (late 1979) lease sale of offshore tracts in the Beaufort Sea is an important portent that the technology to produce and deliver petroleum from offshore areas of the Arctic will be developed. The U.S. Bering Sea may prove to be as fruitful, if not more difficult, than the North Sea. The U.S. Department of the Interior, Bureau of Land Management, has published lease sale schedules which are summarized in Figure 1.1. Although subject to revision, there is little doubt that exploration and production will proceed.

The U.S. and Canadian Arctic are not the only ice-covered areas which are being developed. The Russians and Japanese are proceeding with plans to develop petroleum reserves offshore Sakhalin Island and the Chinese are expanding operations in Po Hai Bay with Japanese help. Both of these areas are subjected to heavy seasonal sea ice conditions.

In the Great Lakes, a major effort has been undertaken by both government and industry to achieve year-round transportation in an area where eight months a year was previously the rule. To expand the eight month operating season, a variety of systems had to be developed to permit commercial vessel operation through the ice bottleneck portions of the Great Lakes. Progress in this area

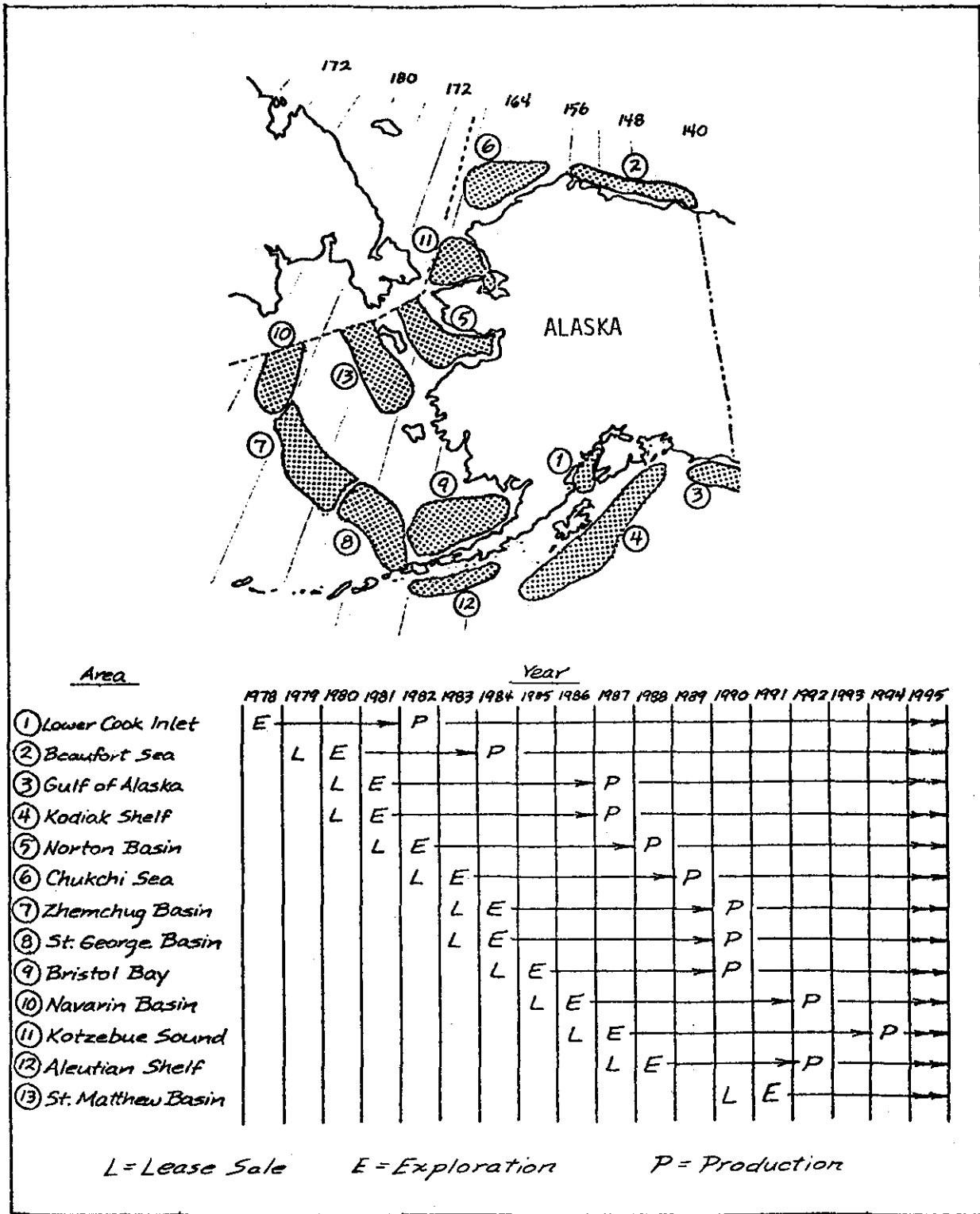

Figure 1.1 Projected Offshore Alaska Commercial Development

was initially slow but within a period of seven years, year-round operation has been achieved on some routes. Today, both industry and government realize the benefits of year-round shipping within the Great Lakes and new ship construction reflects the capability for year-round transportation.

The focus of this report is on the required hull strength for ships to be operated in ice. The classification societies provide guidelines for the strengthening of ice-transiting ships. In order to implement these guidelines, however, the ship owner must select the class of ice strengthening for a vessel. The information and guidance upon which to base such a selection is, in many cases, inadequate. It is not at all clear how a particular trade route (area and month) is related to medium, severe, or extreme ice conditions as described in some of the classification rules. Nor has any relationship relating ice thickness and type with an ice class been shown.

The Canadian Government, much to its credit, did recognize the dependence of appropriate ice strengthening on ice conditions. The CANADIAN ARCTIC SHIPPING POLLUTION PREVENTION REGULATIONS (CASPPR) specify degree of ice strengthening in terms of geographic location and season (monthly). An examination of the Canadian ASPPR ice strengthening requirements shows that the ASPPR requires greater and, in some cases, much greater ice strengthening than those required by classification societies in the design of U.S. Coast Guard icebreakers. Nevertheless, recently two Canadian ships, one an icebreaker and the other a commercial icebreaking ship, suffered extensive hull damage while operating in an ice zone specified by the CASPPR.

These and other deficiencies in selecting adequate ice strengthening criteria, combined with the recognition of the near-term growth in the number of ice-transiting vessels, led the Ship Structure Committee to address the need to develop a basis for the rational selection of ice strengthening criteria.

1.3 Approach

In the next section, the problems of ice strengthening will be discussed in detail and defined in meaningful terms. Subsequent sections focus on the key variable over which there is no control and, as will be shown, about which little is known--the environment; material properties are described and criteria proposed. It appears that the importance of materials is fully recognized and that it is reasonably within the state-of-the-art to describe adequate materials criteria. Existing ice strengthening criteria are compared in detail, including load-carrying capacity, weight, and cost for three specific applications. Certain general and specific shortcomings of various criteria are identified. Specific and general experience with operations of ice strengthened ships in ice is examined. Some statistical summaries are presented and an analysis of a dramatic ice strengthening failure is included.

During this project, certain elements, which are essential to a rational approach to ice strengthening, became obvious. These key elements are combined into a proposed framework for rational ice strengthening. The framework, or approach, to ice strengthening criteria is proposed although there are many specific details which are not now known. These areas of the unknown become the basis for the recommended R&D program.

2. PROBLEM DEFINITION

2.1 Introduction

To effectively define the problem, the objective of the program, as stated in Section 1, must be broken down into elements and defined in terms which are meaningful to the designer. Accordingly, the general objective, to develop a rational basis for ice-strengthening ships, was broken down following the Ship Structure Committee's Long Range Goals:

- Planning and R&D
- Load Criteria
- Response Criteria
- Materials Criteria
- Fabrication Criteria
- Reliability
- Design

Load criteria, response criteria, and reliability are discussed in detail in the following subsections. Section 4 presents the materials and fabrication criteria. Planning and R&D are discussed in Section 9. The design element was not treated in this study.

2.1.1 Load Criteria

Load criteria must somehow be related to ice properties, ice conditions, ice features, the interaction between the ship and the ice, and, ultimately, to the fundamental design parameters of trade route (including season) and acceptable level of risk. The specification of the load must be compatible with the analytic techniques to be applied in evaluating the response element of the ice strengthening criteria.

2.1.2 Response Criteria

Response criteria must include consideration of the methods for analyzing the structure's response to loads, as well as the index of satisfactory structural performance. Consideration of a particular analytical tool, e.g. finite-element analysis or plastic analysis, is not intended to preempt alternative analytical methods. One or more methods must be considered in detail to ensure that the nature of the load definition is complete or adequate for analysis, even though alternative methods are accepted as valid.

2.1.3 Materials and Fabrication Criteria

Material properties and fabrication techniques will be considered together. Material property specifications should be derived from environmental conditions and load criteria. Since this study is limited to normal shipbuilding practices, the only aspects of structural fabrication to be considered are those special fabrication requirements or restrictions imposed by the materials themselves.

2.1.4 Reliability

The state of knowledge of ice-imposed loads does not warrant a quantitative approach to structural reliability. However, the factors which must be considered are identified and a subjective approach to factors-of-safety is proposed.

2.2 Definition of Load

The load should be defined in terms of an intensity (pressure, psi), a description of that intensity over the hull surface (x, y extent, and variation with location); the rate of application or generation of the load, and the intensity-frequency distribution expected over the ship's life. It has been shown [E-14] that the rate of application is not significant in the response of the structure of the ship, but it may be an important variable in determining the load which the crushing ice can impose on the ship.

An implicit element of any criterion is that the ice will fail, or the load will be relieved by other mechanisms or motion, before the structure fails. Therefore, it is necessary to study the load-carrying ability of the different kinds of ice under consideration.

2.2.1 Ice Properties

Michel [A-25] provides an excellent compilation of research data and interpretation pertinent to ice properties. Some of the well-known properties are:

- Ice is a polycrystalline material found in nature with totally random crystal orientation and with varying degrees of preferred orientation. When a strong preferred orientation exists, generally designated in terms of the "c-axis", the ice is anisotropic, being stronger in the direction parallel to the c-axis orientation.

- Important mechanical properties of ice are strongly temperature dependent. As a result, ice strength varies with temperature through the ice sheet, decreasing from the colder air temperatures to the warmer water temperatures.

- Ice strength is dependent on the salinity of the ice. A consequence of this is that fresh water ice is generally stronger than sea ice and old, multi-year ice, which loses salinity with warming and refreezing, is stronger than newly frozen sea ice.

- Ice strength is strain-rate dependent, exhibiting almost perfect plastic properties at strain rates in the creep (10^{-4} sec $^{-1}$) range. The transition to elastic behavior occurs around 10^{-2} sec $^{-1}$. The quantity of pertinent data is almost inversely proportional to the strain rate, much of the research having focused on the plastic-creep behavior of glaciers. There are data which indicate that ice behaves elastically for some range of strain rates greater than 10^{-2} sec $^{-1}$. However, there are virtually no data available in the open literature at strain rates which may be characteristic of ship-ice interactions. Some proprietary research has been performed which indicates that entirely different failure modes are induced at very high rates of loading. Figure 2.1 is a combination of some generalized information from Michel [A-25] and a qualitative representation of the proprietary research results.

- Ice strength, as in the case of many materials, is dependent on the method of measuring it. Of particular importance is the dependence of crushing strength on confining pressure. Uniaxial crushing strength ranges from 100 psi to 500 psi depending on direction, temperature, salinity, and strain rate. The maximum triaxial crushing strength may be several times the uniaxial. Virtually all of the data available are for uniaxial tests. Some research has been conducted on the triaxial strength of ice but the results of these efforts are proprietary.

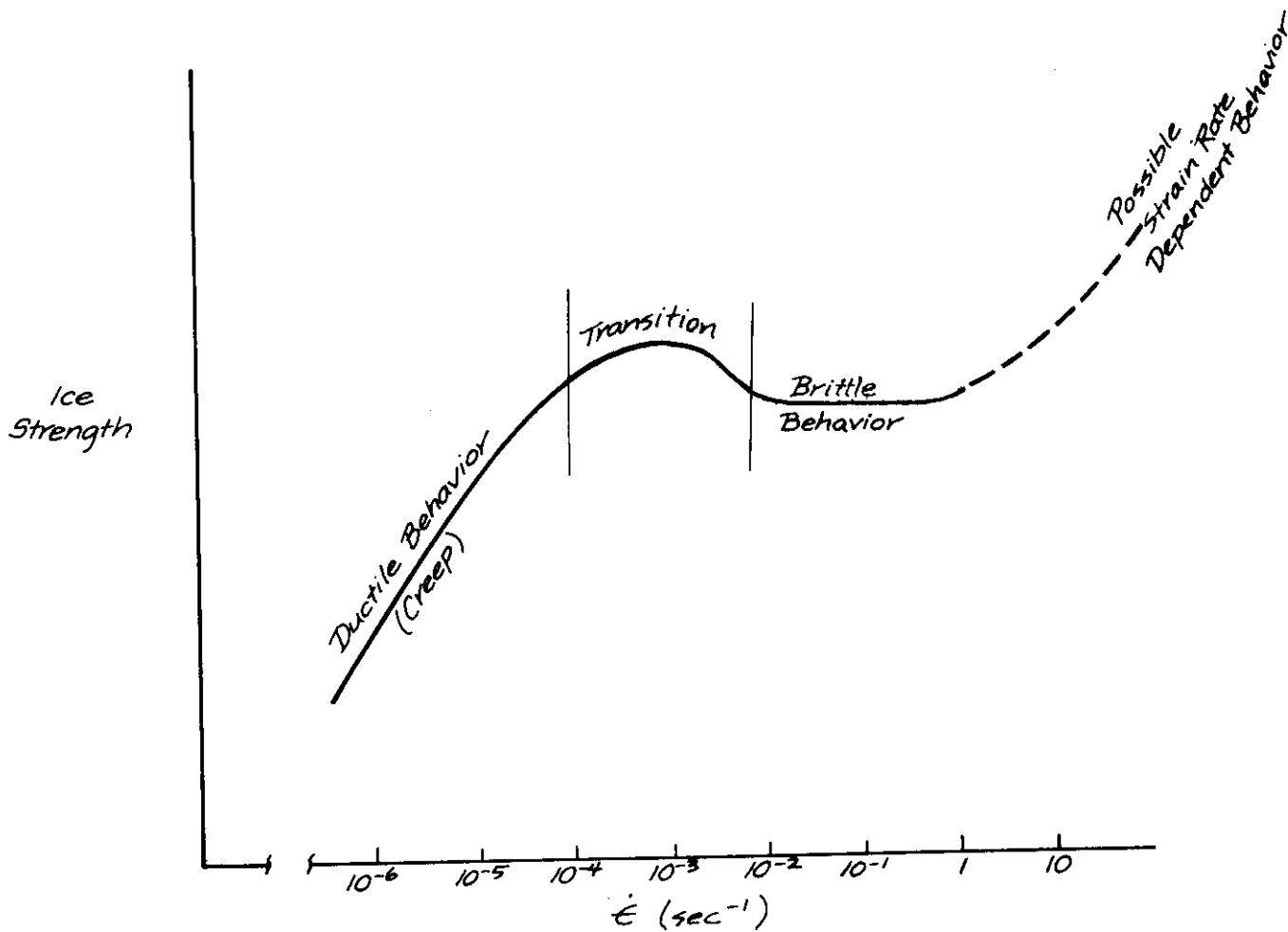

Figure 2.1 General Effect of Strain Rate on Ice Strength

In terms of ship-ice interaction, neither triaxial nor uniaxial test results are directly applicable. As the ice is crushed by the ship, the crushing interface of the ice and the failure zone immediately behind it are confined to some degree by the surrounding ice. This self-confinement does increase the crushing strength through the triaxial mechanism, although there are no quantitative data which can be used directly. "Bore-hole" tests [A-19] of ice-crushing strength bring the appropriate mechanisms into play and are pertinent. This is an experiment in which a hydraulic cylinder jack is placed horizontally in a vertical hole in the ice. A pressure-time (or displacement) record is made as the jack is forced against the walls of the hole. An example is shown in Figure 2.2. The peak stress imposed can be calculated from the pressure and appropriate areas. Although there is no known exact relationship between this stress and those developed in a ship-ice interaction, it is felt that this method provides a "handle" for accounting for the self-confined, partial triaxial strength of ice. Unfortunately, there are no bore-hole test results available in the open literature.

Experience has shown that, as ice sample size increases from laboratory scale to field test scale, ice strength appears to decrease. This is due to the inclusion of more natural defects in the test specimen. To date, no really large (several meters) scale tests of ice properties have been made available to the public. A proprietary program for such tests is currently entering a second year.

2.2.2 Hull-Ice Interaction

The real phenomena involved as a ship transits ice-covered waters are dynamic, unsteady, and very complex. The resistive components of the hull-ice interaction have been studied from purely theoretical, purely empirical, and combined semi-empirical viewpoints. The results of several years of research and analysis have led to a state-of-the-art in predicting the resistance of ships in ice roughly equivalent to that achievable for open water in Froude's day. The state of the art in predicting structural forces acting on a ship's hull in ice is much more rudimentary. This is due primarily to the limited full-scale data which have been collected.

One such set of full-scale structural data comes from the MACKINAW trials [B-7]. It was shown that the ice load varies both in space (location on the hull) and time. It is neither a simple concentrated load nor a purely distributed load. Edwards, et al [B-7] describe the spatial and temporal variation of the ice loads. Since the observed parameter was structural response (strain-gage arrays), the description of the actual load is at best ambiguous. No simple generalization was found which described the load.

A purely analytical mathematical model has been developed [B-26,B-38]. This is essentially a rigid-body mechanics treatment of the collision of a ship with ice. The resulting force is calculated by a computer program in a time-step sequence. The main factors considered are:

- Elastic and nonelastic response of ice in crushing and bending.
- Rigid-body motions of the ship and, in the case of discrete ice floes, the ice.
- The hydrodynamics effects, added mass, and damping.

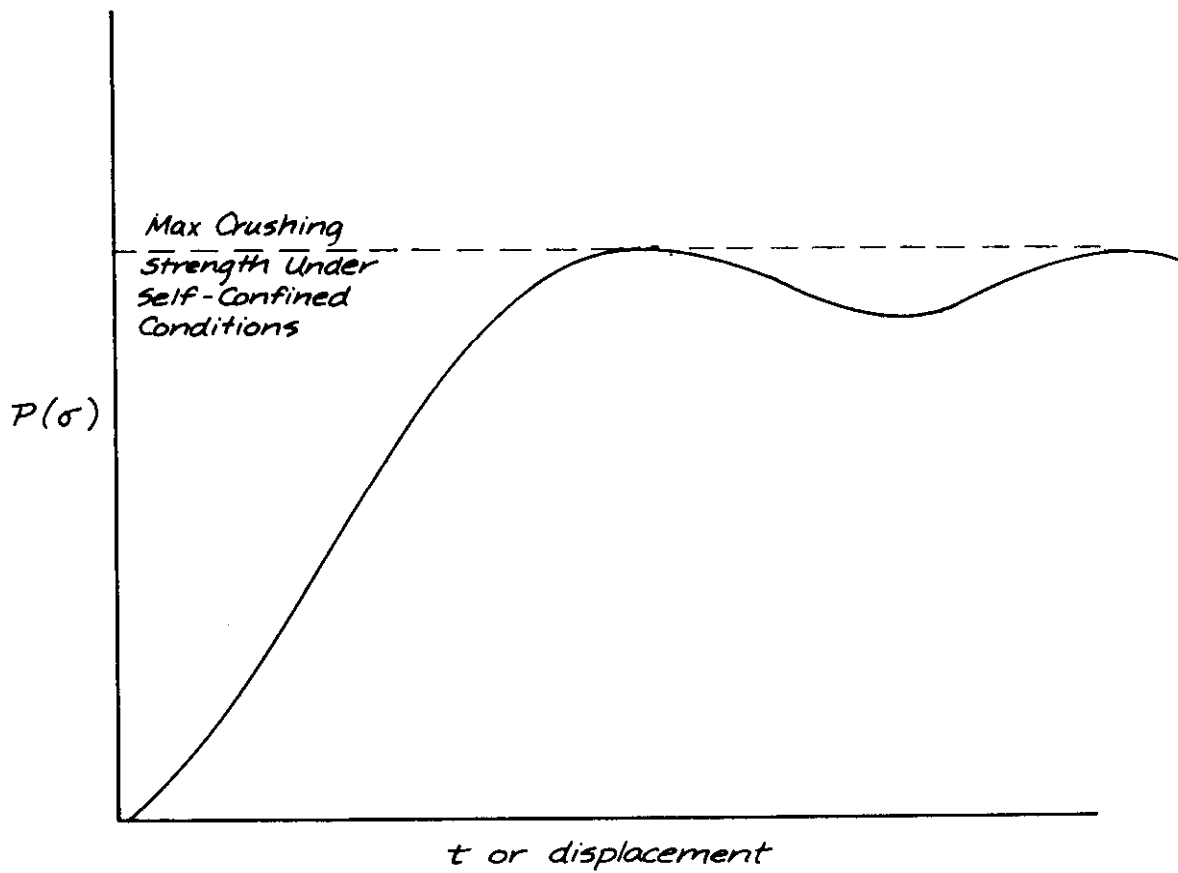

Figure 2.2 Bore-Hole Jack Test Results

- The shape, in terms of direction cosines, of the ship's hull.
- Speed and size of the ship.
- Thickness, size of ice floes, and properties of ice.

The approach is explained in detail by Major, et al [B-26]. In that paper, the results of exercising the mathematical model are compared with full-scale results of the MACKINAW trials. Interpretation of the MACKINAW data is so difficult that all that can be said about the comparison is that the two methods are in agreement in the order of magnitude and in the most general of terms. Nevertheless, the analytical method should accurately reflect the dependence of ice induced forces on the key parameters.

2.2.2.1 Application of Analytical Model of Hull-Ice Interaction - This section presents the results of the analysis of selected cases of impact between ship and various ice features. Its main objective is to study the effect of variation of key parameters on the ice load. It is not intended to validate the prediction program nor to reproduce ice conditions which can inflict damage on the selected ship. In fact, the MV ARCTIC, a 28,000 DWT bulk carrier, was chosen for this work.

A total of 18 runs were specified for the following conditions:

Level Ice:	$h = 1, 3, \text{ and } 6 \text{ ft}$
Discrete Floes:	$D = 50, 200, \text{ and } 500 \text{ ft}$
Bergy Bits:	$h = 10 \text{ and } 20 \text{ ft}$
Crushing Strength:	$\sigma_c = 300, 1000, \text{ and } 2000 \text{ psi}$
Speed:	$v = 6 \text{ and } 12 \text{ kts}$

where

h = ice thickness
 D = diameter

All runs were made using the MV ARCTIC as built except for three cases where a scaled-up MV ARCTIC ($\Delta = 150,000$ short tons) was used. Table 2.1 provides details of the selected runs.

2.2.2.2 Ship Characteristics and Input Data - The major characteristics for the MV ARCTIC (as built) are given in Table 2.2.

To develop the characteristics for a scaled-up ship, the deadweight tonnage was used as a basis for the scaling factor:

$$\lambda = \left[\frac{\text{DWT (Scaled-Up Ship)}}{\text{DWT (As Built)}} \right]^{1/3}$$

For a scaled-up MV ARCTIC of 100,000 tons DWT, the scaling factor is 1.527 and the displacement of the large ship equals 134,206 L. tons (136,360 tonnes) as compared to 37,704 L. tons (38,309 tonnes) of the as-built ship.

Applying this scaling factor to the as-built ship resulted in ship characteristics for the scaled-up vessel. Table 2.3 presents a summary of data

TABLE 2.1
SELECTED CASES FOR ICE LOAD PREDICTIONS

SHIP	ICE TYPE	CASE NO.	ICE THICKNESS, h (ft)	IMPACT VELOCITY, v (knots)	FLOE DIAMETER, D (ft)	ICE CRUSHING STRENGTH, σ_c (psi)
MV ARCTIC (as built)	Level ice	1	1.0	6.0	∞	300
		2	3.0	6.0	∞	300
		3	3.0	12.0	∞	300
		4	3.0	6.0	∞	1,000
		5	3.0	6.0	∞	2,000
		6	6.0	6.0	∞	300
	Discrete Floes	7	3.0	12.0	50	300
		8	3.0	12.0	200	300
		9	3.0	12.0	500	300
		10	3.0	12.0	200	1,000
		11	3.0	12.0	200	2,000
		12	3.0	6.0	200	300
		13	6.0	12.0	200	300
	Bergy Bits	14	20.0	12.0	50	1,000
		15	10.0	12.0	50	1,000
MV ARCTIC ($\Delta = 134,206$ LT)	Level Ice	16	6.0	6.0	∞	300
	Discrete Floes	17	3.0	12.0	200	300
	Bergy Bits	18	20.0	12.0	50	1,000

TABLE 2.2

SERIAL # 1	MODEL HULL DATA SHEET										DESIGNATION
VESSEL NAME & HULL FORM	MV ARCTIC (14,770 HP) (27,650 L ton DWT)										SCALE FS
<u>*DIMENSIONAL PARAMETERS</u>											
$L = 645.33$ ft					$C_b = 0.759$						
$B = 75.00$ ft					$C_{bf} = 0.798$						
$H = 50.00$ ft					$C_p = 0.764$						
$T = 36.00$					$C_w = 0.876$						
$\nabla = 1,317,150$ ft ³					$C_{wf} =$						
$\Delta = 37,764$ L ton					$C_m = 0.991$						
<u>**NONDIMENSIONAL PARAMETERS</u>											
$L/B = 8.60$					$\gamma_0 = 30^\circ$						
$B/T = 2.084$					$\beta_5 = 0^\circ$						
					GEOMETRY-FRICTION COEFFICIENTS						
$\mu_0 = 1.650$					f		μ_1		μ_2		
$\eta_2 = 2.620$					0.000		0.650		0.382		
FRICTION FACTORS, f :											
$f = 0.2$											
FOREBODY WATERPLANE ANGLES											
STATION	10 (FP)	9 $\frac{3}{4}$	9 $\frac{1}{2}$	9 $\frac{1}{4}$	9	8 $\frac{3}{4}$	8 $\frac{1}{2}$	8 $\frac{1}{4}$	8	7 $\frac{3}{4}$	7 $\frac{1}{2}$
α°	32.8	30.8	27.2	21.8	15.2	10.3	6.3	2.9	0	0	0
β°	55.4	44.1	35.0	27.2	19.6	12.3	6.3	2.4	0	0	0

TABLE 2.3

COMPARISON OF CHARACTERISTICS OF
MV ARCTIC AS BUILT AND SCALED-UP SHIP

SHIP	AS BUILT	SCALED-UP
DWT, LT	27,690	100,000
POWER, HP	14,770	100,000
LENGTH, ft	645.0	985.0
BEAM, ft	75.0	114.5
HEIGHT, ft	50.0	76.4
DRAFT, ft	36.0	55.0
DISPLACEMENT, LT	37,704	134,206

for both ships, noting that the form coefficients remain unchanged for the scaled-up ship; i.e. the shape and hull angles are identical.

The location of impact was arbitrarily selected in the vicinity of the area where damage was known to occur. The approximate bow damage area on the MV ARCTIC was estimated to span a region bounded by Frames 176 and 185, and between the 19 ft and 30 ft waterlines. The location of impact was selected close to the center of the damaged area. This impact location was geometrically identical for the scaled-up ship. The characteristics of the impact point for both ships are given as follows:

	α	β	X	Y
MV ARCTIC	21.80	27.2	274.27	25.33
Scaled-Up ARCTIC	21.80	27.2	418.83	28.68

where

α = angle of shell plating to centerline in the half breadth plan

β = angle of shell plating to vertical in the body plan

X, Y = waterline coordinates of the impact as illustrated below

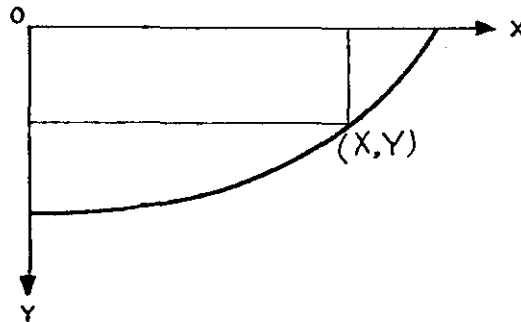

2.2.2.3 Results and Discussions - The ice load was estimated using a specially developed computer capability at ARCTEC CANADA LIMITED. The results of the selected runs are given in Table 2.4 where the test conditions are also listed. In addition to the selected ice crushing strength, the following ice properties were assumed:

Flexural Strength = 72.52 psi (500 kPa)

Elastic Modulus = 427,000 psi (2942 MPa)

Poisson's Ratio = 0.33

TABLE 2.4
RESULTS

RUN NO.	IMPACT CONDITIONS					RESULTS				
	IMPACT VELOCITY (knots)	ICE THICKNESS (ft)	FLOE DIAMETER (ft)	ICE CRUSHING STRENGTH (psi)	IMPACT FORCE (L ton)	AREA OF CONTACT (ft ²)	TIME TO MAXIMUM FORCE (sec)	REDUCED FWD SPEED AT MAX FORCE (knots)		
MV ARCTIC (as built)	Level ice	1	6.0	1.0	∞	300	52.18	2.42	.04	6.00
		2	6.0	3.0	∞	300	313.94	14.53	.09	5.99
		3	12.0	3.0	∞	300	660.38	30.57	.06	11.98
		4	6.0	3.0	∞	1,000	449.06	6.24	.07	5.98
		5	6.0	3.0	∞	2,000	533.59	3.71	.066	5.98
		6	6.0	6.0	∞	300	938.53	43.45	.160	5.97
MV ARCTIC (Δ = 134,206 LT)	Discrete floes	7	12.0	3.0	50	300	419.17	21.73	.200	11.99
		8	12.0	3.0	200	300	515.44	23.86	.070	11.99
		9	12.0	3.0	500	300	623.60	28.87	.060	11.99
		10	12.0	3.0	200	1,000	841.65	11.69	.050	11.98
		11	12.0	3.0	200	2,000	1090.75	7.57	.045	11.96
		12	6.0	3.0	200	300	257.44	11.92	.103	5.99
MV ARCTIC (Δ = 134,206 LT)	Bergy bits	13	12.0	6.0	200	300	3906.29	202.49	.560	11.70
		14	12.0	20.0	50	1,000	2048.81	31.86	.240	11.94
		15	12.0	10.0	50	1,000	1388.71	21.60	.200	11.96
MV ARCTIC (Δ = 134,206 LT)	Level ice	16	6.0	6.0	∞	300	938.53	43.45	.155	5.99
		17	12.0	3.0	200	300	515.44	23.86	.067	11.99
		18	12.0	20.0	50	1,000	2069.77	32.19	.240	11.99

It is shown that in level ice, failure occurs in bending after initial crushing to develop sufficient load to fail the ice. Therefore, a trend of increasing load with increased ice thickness is obvious. A maximum of 938.5 L. tons occurs at 6 knots in 6 ft ice. We note that the ship size does not affect the maximum load in this case (compare #6 and #16) due to the fact that ice failure in bending is independent of the impacting body. It is not surprising to observe the same thing in small, thin floes or small bergy bits because the ice mass is rather small compared to the ship, and hence, a small difference is to be expected. It appears, on this basis, that large ice masses of probably similar mass to the ship and of sufficient depth may be investigated to add a third dimension to the present information.

Effects of ice thickness, crushing strength, and impact speed are illustrated in Figures 2.3, 2.4, and 2.5 respectively. Figure 2.3 shows that the largest ice loads are to be expected during continuous crushing of an ice floe, as in case #3. If the ice is thin, it fails in bending (as in level ice) and if its mass is small compared to the ship, it can easily be pushed away by ship impact. The largest bergy bit used weighed only 2400 tons, which is approximately 6% of the ship's mass. Figure 2.4 illustrates clearly the effect of crushing strength on the ice loads. It shows a larger influence during impact with discrete floes than level ice. The effect of speed is also shown in Figure 2.5 to be quite significant.

It should be noted that the highest observed load was approximately 4000 tons and it occurred when the ship hit a 200 ft floe, 6 ft thick. This floe was small and thick, so it would not fail in bending and, therefore, had to be crushed and pushed away. Its mass was only 4800 L. tons, i.e., 13% of MV ARCTIC's displacement.

2.3 Definition of Structural Response

Ultimately, the structural response is defined by the presence or absence of elastic strain, yielding, collapse, fracture, etc. of the structural components under the influence of the load. These terms are all used in the sense of the common structural mechanics' definitions. Since we are dealing primarily with this problem in the abstract, the structural response must be synthesized by analytical techniques. These techniques then become integrated into the problem definition and, either explicitly or implicitly, into the basis for the ice strengthening criteria. It is important to keep the influence of the analytical techniques in focus. Although it may be preferable to express a criterion independent of the analytical technique, it will be necessary to choose some particular technique for illustration, comparison, and evaluation purposes.

The requirements for the analytical techniques to be applied are:

- Be reasonably accurate, with the inaccuracies known and documented. Gross conservatism should be avoided and factors of safety explicitly applied.
- Be reasonably easy to use, since the criteria will be applied early and often in a normal design spiral.
- Should reflect the real phenomena to the maximum extent consistent with keeping it simple.

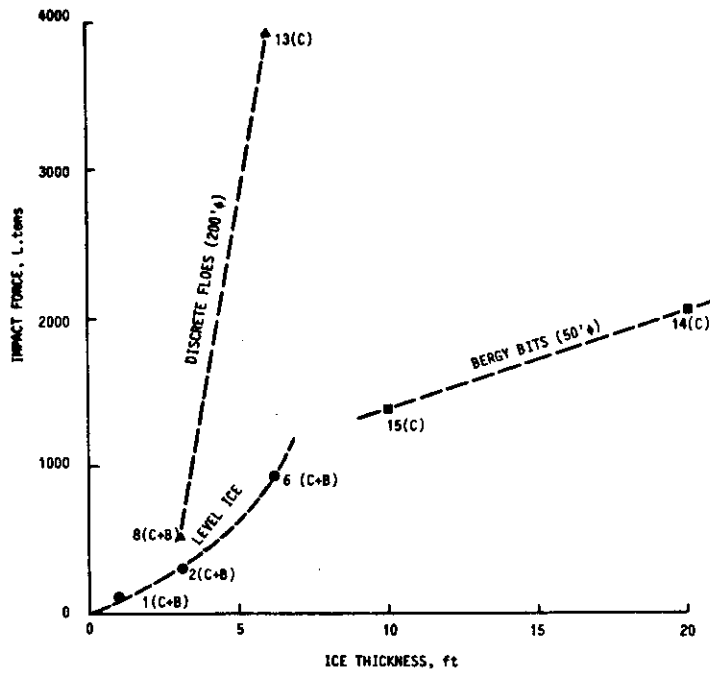

C = pure mode, C+B = crushing and bending mode

Figure 2.3 Effect of Ice Thickness and Failure Mode on Maximum Ice Impact Force

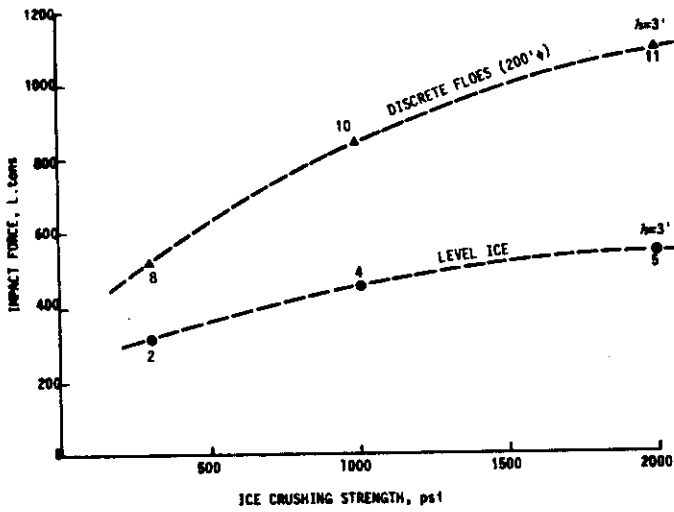

Figure 2.4 Effect of Crushing Strength in Crushing-Bending Failure Mode

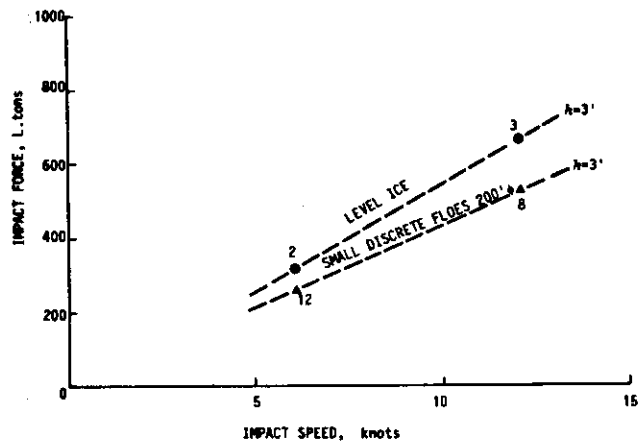

Figure 2.5 Effect of Impact Speed on Maximum Ice Load

2.3.1 Structural Response - Plating

Several noted structural analysts have published papers in which the point was made that the load-bearing capacity of a panel, plate, or structural element is much greater if plastic deformations are accepted. The three plastic hinge method suggested by Johansson [E-13] indicates twice the load capacity compared to the elastic design to yield. Jones [E-14] points out that at a permanent set in plating equal to the thickness of the plate, the load capacity is twice again, i.e. four times the elastic yield condition.

Plastic behavior of plates can be synthesized in finite-element methods. Properly done, these solutions are more precise than the rigid plastic methods. They are, however, much more complex and are not amenable to the recycling of early design studies.

2.3.2 Structural Response - Framing

Both plastic and finite-element approaches to framing design are available in addition to various grillage and truss techniques for elastic design. An important factor in the consideration of analysis techniques for ice strengthening of ship's frames is experience (for more detail, see Section 6.2). The U.S. Coast Guard's experience [G-1] is that the failures of icebreaker hulls have predominantly been due to framing failures. Both instability, the result of imperfect structural detailing, and plastic collapse have been observed in the frames, but no significant failures of the plates between the frames have been observed. This reflects a clear imbalance in the approach to specification of criteria.

The simple plastic analysis by Johansson [E-13] results in workable and easily understood relationships. The shortcoming, however, as pointed out by Jones [E-14] is that the single-failure mode used is not necessarily the actual collapse mechanism and is, in essence, a kind of incomplete "upper bound" solution.

The techniques of limit analysis could be systematically applied until all of the possible collapse mechanisms have been examined to determine if there is a failure mode at a lower load. These techniques have been refined for civil engineering practice, but are not commonly used in marine practice.

Finally, whatever degree of sophistication is used to synthesize the structural response of a framing system to ice loads, the execution of the design, in terms of structural detailing and workmanship, may be the predominant factor in the ultimate load-carrying capacity. In view of this, a simple structural response analysis will be recommended and appropriate safety factors applied.

2.4 Reliability

Probabilistic methods of ship design are emerging and the growing importance of these methods was forecast by Professor Evans [E-8]. Although wave bending moments may be expressed in statistical terms, a rigorous statistical method is still not available for normal ship design. Mansour and Faulkner, in Chapter 4 of Ref. [E-8] acknowledge that the techniques are only useful for comparison.

The demands of operating in heavy ice clearly present a "significant departure" from the bulk of ship design experience according to Professor Caldwell in Chapter 13 of Ref. [E-8]. This means that there is no basis for extrapolation from valid experience; from Baltic Sea operations, for example, to the very large icebreaking ships foreseen as likely candidates to exploit the mineral resources of the Arctic. Without the benefit of evolutionary development, "the need for a more deterministic approach to design becomes imperative" [E-8].

It has been shown in previous sections that the current knowledge and understanding of the problem is insufficient for a complete, closed analytical approach to a design for ships operating in ice. The loads cannot be described with precision and the structure's response to those loads cannot be synthesized. Nevertheless, it is important that the approach to ice strengthening preserves the framework upon which to build; first to the analytical deterministic level and ultimately to the statistical level. For, in the absence of extensive experience, it is only through these methods that a measure of an ice strengthened structure's reliability may be made. Hopefully, an approach which uses identified load factors and limit response factors [E-8, E-12] can be devised.

3. ENVIRONMENT

3.1 Introduction

The purpose of this section is to develop representative maximum ice conditions as a function of calendar time for the U.S. and Canadian Arctic, the Great Lakes, Gulf of St. Lawrence, the Baltic Sea, and Antarctica. It must be initially understood that the quantity and quality of data are limited and liberal interpretation of available data has been required. Prior to the historic ice-breaking voyage of the SS MANHATTAN, the WIND Class and GLACIER icebreakers operated in western Alaskan waters. Data from cruise reports on ice thicknesses and irregular ice features suitable for use in technical design are virtually nonexistent. Missions for these ships were primarily operational in nature and few attempts were made to physically measure ice thicknesses. Similar results can be reported for the other ice-covered regions of the world. After the SS MANHATTAN voyages and the decision to build the Alaskan pipeline, it became obvious that little was known about the environmental conditions affecting Arctic marine equipment. Programs were subsequently initiated, but at relatively low funding levels, and not on an on-going annual basis, to obtain field data. Only in the last three to four years have serious attempts been made to learn the governing ice features which dictate design criteria. Historically, operators of marine vessels have done everything to avoid severe ice conditions. Once encountered, however, it was usually followed by sleepless nights to get through to light ice, with no attempts to measure or define the constraining mass of ice.

For most geographic areas, ice is dynamic and always in motion. The ice motions are initiated by wind and currents acting on the ice surfaces. Reports in the Bibliography can provide details on ice dynamics and behavior. Needless to say, there would be flat ice everywhere were it not for external forces on level ice. It is the irregular (non-level ice) features that govern the design of offshore equipments.

3.2 Governing Ice Conditions

Seven prevailing ice conditions are of major importance. These are:

- first-year level ice
- first-year consolidated pressure ridges
- multi-year level ice
- multi-year pressure ridges
- icebergs and ice islands
- bergy bits and growlers
- broken ice

Definitions for these terms are provided in the Appendix. These conditions do not exist for all areas and the variation in annual ice conditions can be significant. As the purpose of the project is related to ice strengthening criteria, the focus on environmental conditions is to make a reasonable determination of ice conditions that may be experienced during a thirty-year period (the expected life of the equipment). It must be noted that such design ice conditions are not suitable for routing or transportation analysis where average annual ice conditions would be more appropriate.

To describe these ice conditions on a consistent basis for the geographic areas of interest on a month by month basis, a standard format needed to be developed. The format selected is as follows:

FY XX
MY XX
IB IS
BI XX

where

FY = first-year ice
MY = multi-year ice
IB = iceberg, bergy bits, growlers, and any other fragments
IS = ice island or fragment therefrom
BI = broken ice
XX = level ice thickness. The corresponding pressure ridge depth (water surface to keel depth) contained within level ice floes is ten times the level ice thickness. The depth of consolidation within the first-year pressure ridge is assumed 25% of the depth; for multi-year ice 50% of the depth is assumed to be consolidated.

A few amplifying notes may be of value at this time. Icebergs, bergy bits, growlers, and ice islands are grouped separately from first-year and multi-year sea ice because they pose a different type of problem to marine equipment. More specifically, the ice strength properties are greater than those of normal sea ice. Furthermore, the bulk volume and mass of these ice features result in ship-ice interactions at the opposite end of the spectrum of dynamics compared to normal sea ice. In most areas (less land-fast ice), pressure ridges exist where ice motion is dynamic. Pressure ridges consist of broken ice pieces resulting from the fracturing of the edge of colliding level ice floes. With air temperatures below freezing, the underwater broken ice pieces refreeze within the ridge and the depth of refreezing is usually of a greater depth than the adjacent level ice floes. As such, they impose a major barrier to marine equipment in terms of strength and mass. An example of how the above format is used may be of value.

Ex. 1. Ice area defined as: FY 5
MY 7

means that within the geographic area, first-year ice of 5 ft thickness with first year pressure ridges having keels of 10 times the level ice thickness or 50 ft. As indicated above, the first-year ridges are consolidated to a depth of 12.5 feet. The multi-year ice is 7 ft thick with 70 ft pressure ridges consolidated to 35 ft. Exceptions to the formulation of maximum keel depth will be noted by a number following the level ice thickness: MY 10-40.

Using this ice classification format, ice conditions for the geographic areas of interest can now be established on a monthly basis. These are shown in the appendices and one example is shown in Figure 3.1.

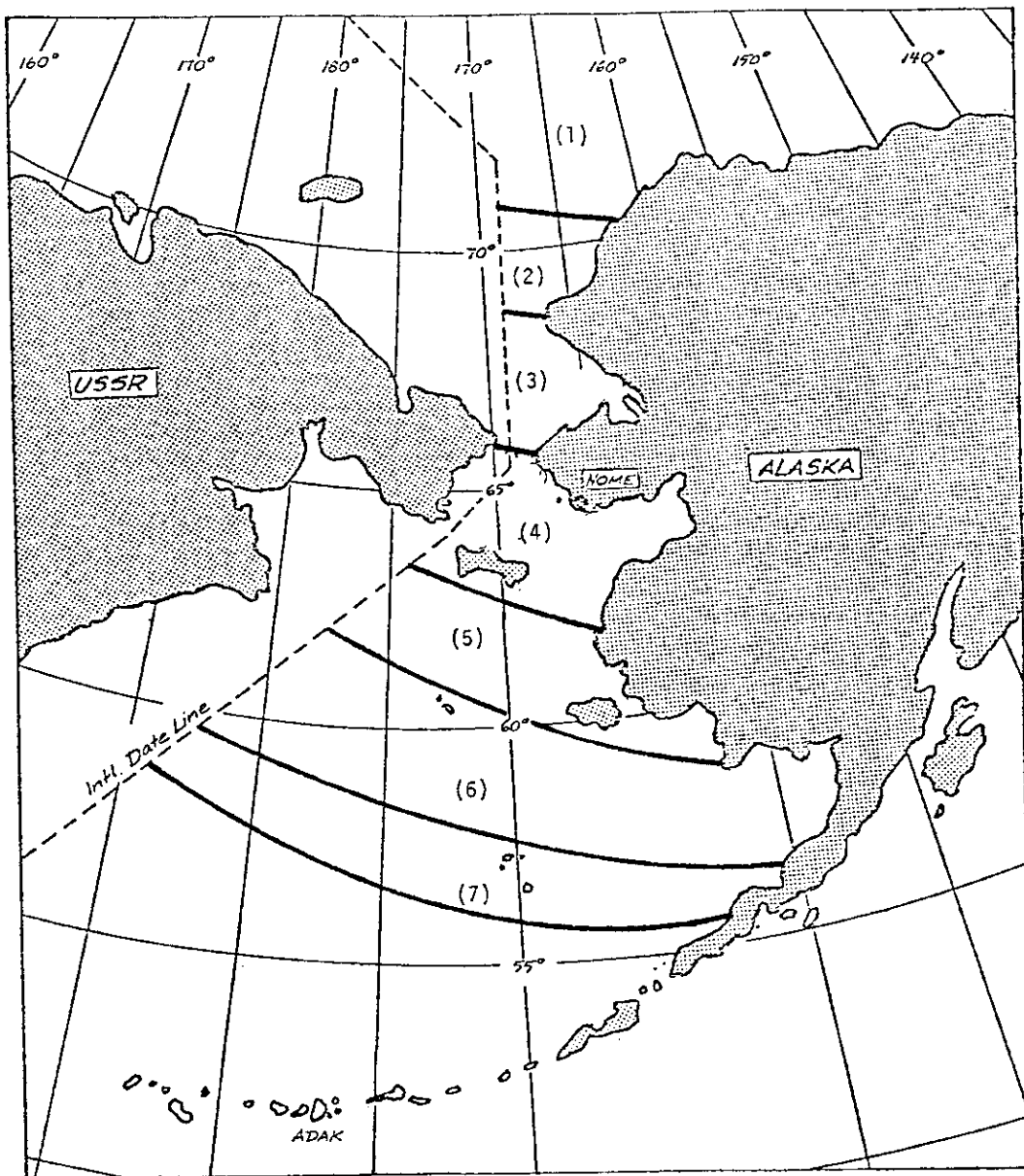

ICE AREA	ICE CHARACTERISTICS
1	FY 6.5; MY 11; IS
2	FY 6; MY 10
3	FY 5; MY 10
4	FY 4
5	FY 3
6	FY 2
7	BI 2

Figure 3.1 Maximum Ice Conditions, April

It should be re-emphasized that delineation of ice thickness within each ice area is based on the maximum ice accretion that can be expected to occur within a thirty-year time period and that marine transportation systems may never experience these conditions. Ice conditions, thickness and areal coverage vary greatly each and every year. Physical measurement of ice conditions in the North Bering Sea [A-41, A-42] have shown that ice floes of four feet level ice thickness constitute less than twenty percent of the floes in April and the number of pressure ridges of forty feet keel depth (ten times the level ice thickness) probably is less than one percent. Furthermore, for this study, knowledge of number of ridges, frequency of encounter, and size variation have been determined to be of little significance for ice strengthening criteria. Rather, worst ice conditions have been defined without assignment on probability of occurrence. It should also be noted that fresh-water ice in the Great Lakes tends to be harder and stronger than normal saline ice of the same thickness in the other geographic areas.

3.3 Sources of Data and Analysis Procedures

As previously mentioned, good ground-truth data are hard to find. Nevertheless, it is possible to estimate with some confidence, reasonable values of governing ice conditions for the geographic areas of interest on a month by month basis. This level of confidence is based on a review of all available literature and, in many cases, communication over the years with people who have been in the geographic areas of interest. From these sources, a rational approach to ice conditions as a function of calendar time has been made.

The intentional limitation of this study to maximum conditions becomes acceptable, even necessary, when the quantity, detail, and quality of the data are considered. Except for a few, one time in depth, field studies [A-41, A-42], there simply are not enough data to support a statistical treatment of the distributions and probability of ice features. In many geographic areas, data are non-existent and in others limited to one year. In these cases, assumptions have been made based on ice conditions in either adjacent areas or an assessment based on knowledge of stable and dynamic ice conditions. It should be noted that prior to the start of the SS MANHATTAN Arctic Marine Project, data collection of environmental conditions in ice-covered U.S. areas could rarely, if ever, be justified except in the name of science. Data which did evolve have only marginal application as it relates to ice strengthening criteria. Even after the Arctic Marine Project, our understanding and knowledge did not appreciably change as commercial development would follow the pipeline system. That being the case, few initiatives were taken to obtain data on the governing environmental conditions offshore.

Without question, additional field data are needed. Projects designed for field data collection should focus on the "worst" ice features in the area rather than the "best". Unfortunately, these data are expensive to take in terms of time, manpower, and other resources. Profiling of one pressure ridge can take all day; whereas, dozens of level ice thicknesses can be obtained during the same time period. Furthermore, profiling of pressure ridges takes special and expensive equipment to accurately measure the physical and mechanical properties of the ridge. There are several systems that can be used for the required collection of environmental data. Helicopters and fixed-wing aircraft can be used to transport personnel and equipment from land-based facilities to the ice and camps subsequently established on the ice for measurement of ice features. An alternate method is to use vehicles that transit on ice, but these vehicles have, to date,

had severe operational limitations in a dynamic ice environment and are usually non-buoyant should the ice fail. Another method is the use of icebreaking ships. These ships have numerous advantages over the other systems in terms of range of operations, available accommodations, and a ready logistics support base. However, the limiting icebreaking capability of the WIND Class icebreakers has historically restricted the area of operation during the severe winter months to portions of the Bering Sea.

With the advent of the POLAR Class icebreakers, in the late 1970's, operations in winter along most of the Alaskan ice-infested coast are now achievable. Deployment of these icebreakers into the more northern trade routes is necessary if sufficient statistical data are to be developed suitable for establishing governing ice conditions and the eventual formulation of improved ice strengthening criteria. Programs of this type are now in progress in the United States and should be established on an annual basis rather than a project by project basis with little continuity. This appears to be recognized by the governments and the quantity and quality of data during the last few years are leading to a better understanding of the governing ice features. However, years of data collection will be required to develop statistical confidence in the governing ice conditions.

4. MATERIALS

4.1 Material Requirements for Ice Strengthened Ships

4.1.1 Introduction

The selection of hull steels for a ship strengthened for navigation in ice represents an important factor in the design of such a vessel, especially if intended for Arctic service. The ship designer must consider that the material should not only withstand the large dynamic loads during icebreaking, but also maintain its original properties at low service temperatures throughout the life of the vessel. In addition, load severity and ambient temperature variations with hull location must be accounted for. In specifying the appropriate materials, the purchasing costs and any additional costs arising from the use of such materials during fabrication and welding must also be considered.

4.1.2 Required Properties

The process of selecting the steels best suited for specific applications involves the study of the environmental conditions, such as operating temperatures and abrasive effects of the ice; and the stresses in the hull components as a function of the expected static and dynamic loads. Stresses govern the thickness of plates and shapes. The thickness is of significance in the choice of materials. Forming, cutting, and welding during fabrication is of importance as well.

It is essential that in the selection of materials for ice strengthened ships the following properties are obtained in order to satisfy the above generalized constraints:

- Adequate Tensile and Yield Strength. Tensile and yield strength have to be high enough to keep material thicknesses within reasonable limits. The relatively high loads in certain areas of the ship's hull caused by ice pressures and impact make the utilization of higher strength steels attractive in order to reduce hull steel weight and fabrication and welding costs.
- Adequate Ductility. Material toughness has to be sufficient enough to avoid brittle fracture at low operating temperatures. Temperatures may be as low as -60°F (-51°C) in the Arctic. This toughness would be reflected in the steel components and welds as the ability to withstand plastic deformation without fracture under maximum static and dynamic loads. The material toughness at low temperatures is evaluated from Charpy V-notch test results, from NDT (nil-ductility transition) temperatures which are determined by drop-weight tests according to ASTM E208-69, and from dynamic tear energy test results. These values have to be established for the base metal, the heat-affected zone, and the weld as such. Figures 4.1 through 4.13 represent examples of such required data.
- Satisfactory Fatigue Characteristics: Many areas of the ship's hull are subjected to repeated dynamic loads of high magnitude. S-N curves and crack propagation rates should be developed for the low temperatures. Allowable stress limits should be selected such that the cumulative fatigue damage during the life of the structure should not lead to a high probability of failure

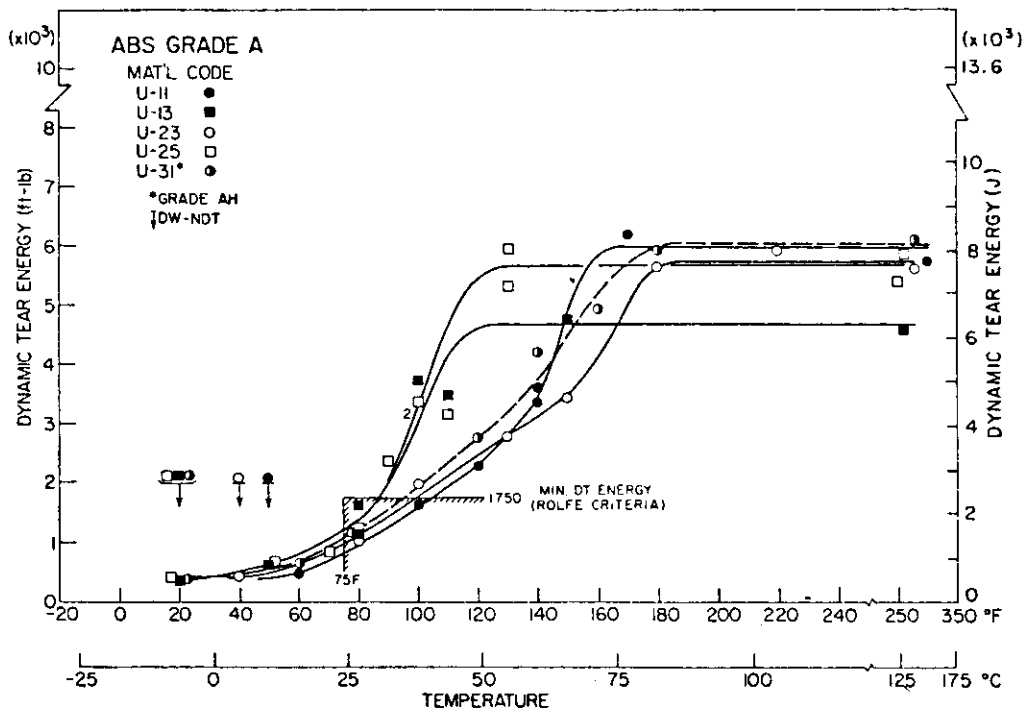

Figure 4.1 Summary of DT Test Performance of the ABS Grade A Plates. The NDT Temperature (Vertical Arrow) Corresponds to the Toe of the DT Curve in each case.

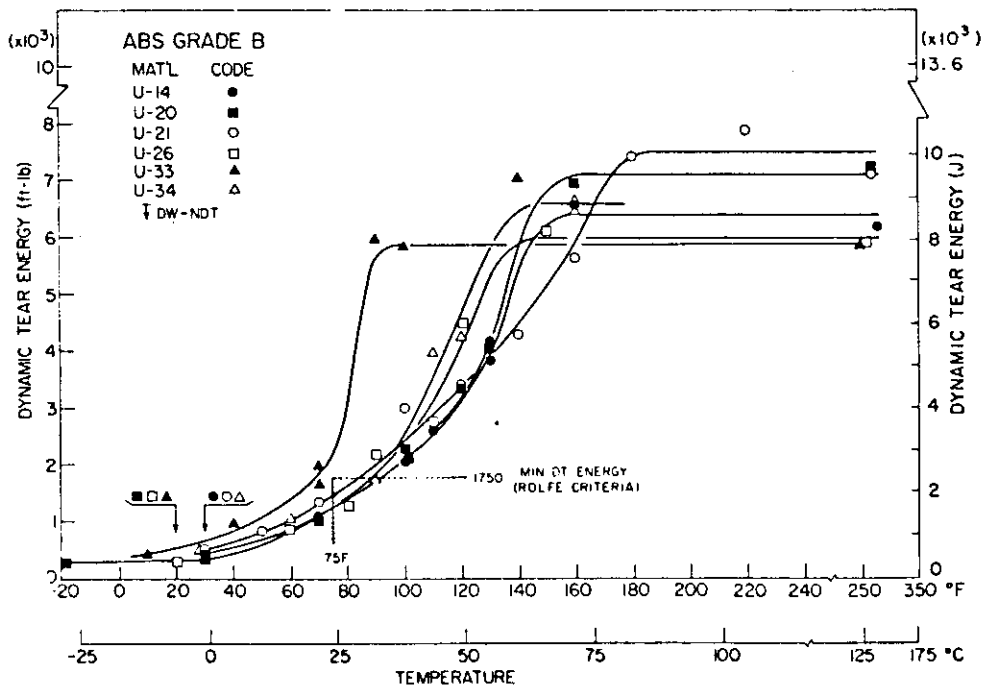

Figure 4.2 Summary of DT Test Performance of the ABS Grade B Plates

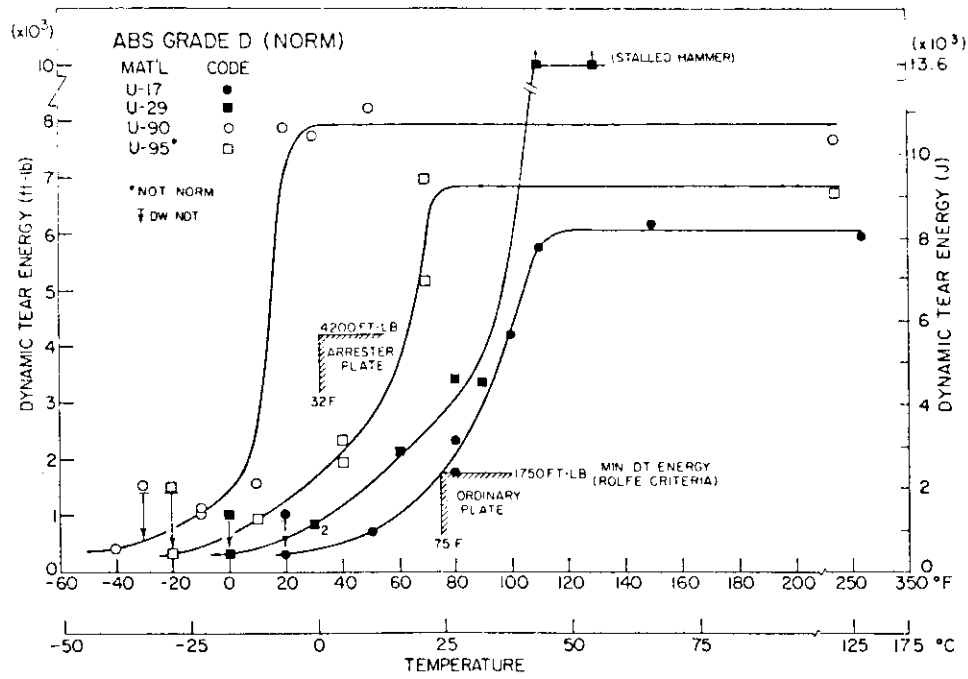

Figure 4.3 Summary of DT Test Performance of Heat Treated (Normalized) ABS Grade D Plates of One As-Rolled ABS Grade D Plate

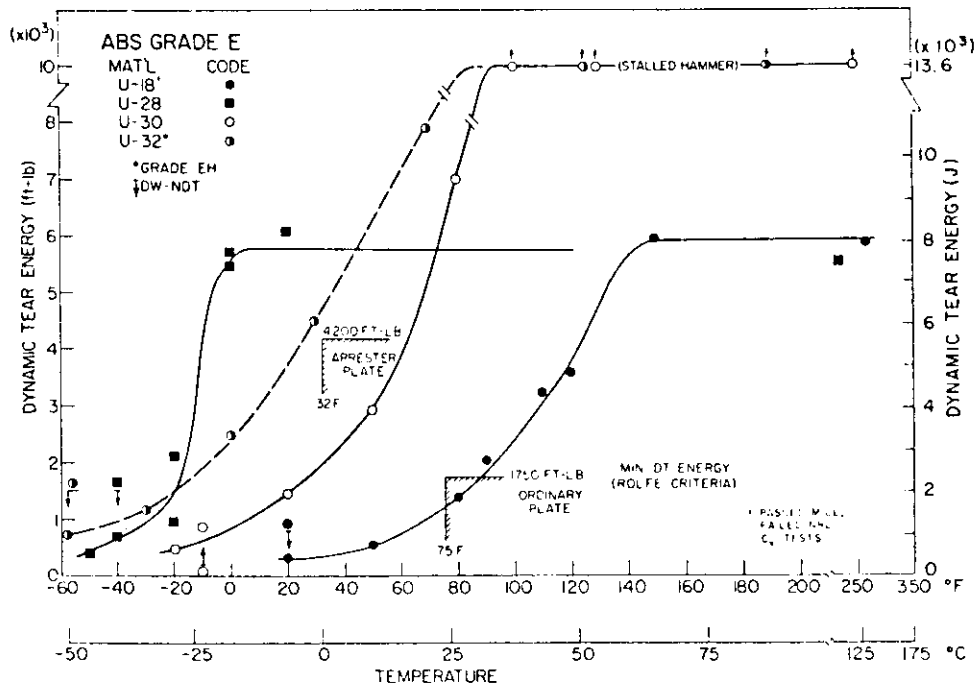

Figure 4.4 Summary of DT Test Performance of ABS Grade E Plates (Grade E Specification Requires Normalization Heat Treatment)

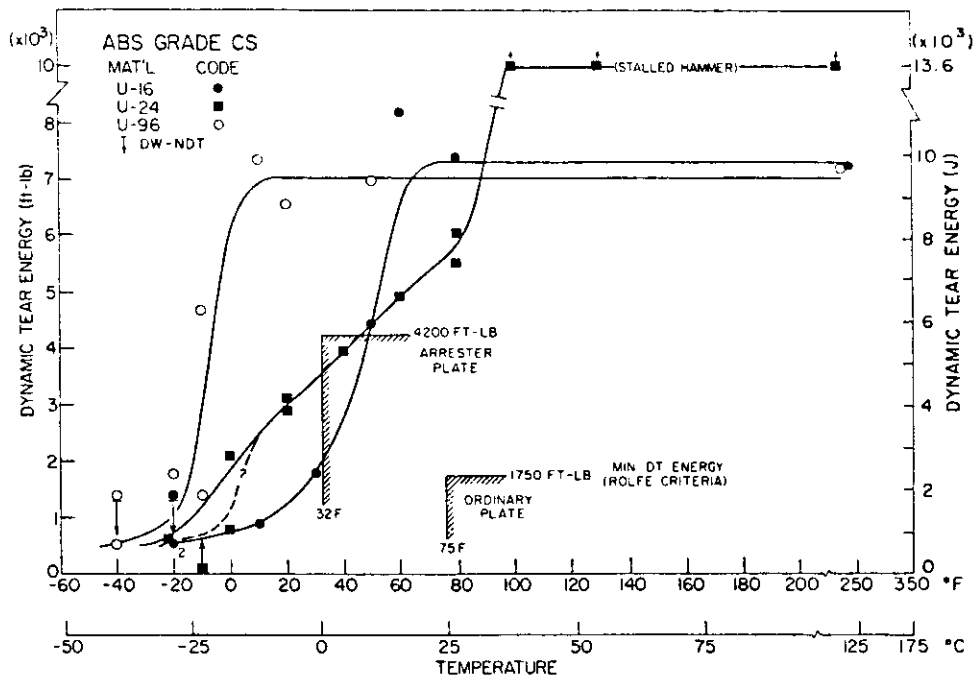

Figure 4.5 Summary of DT Test Performance of ABS Grade CS Plates (Grade CS Specification Requires Normalization Heat Treatment)

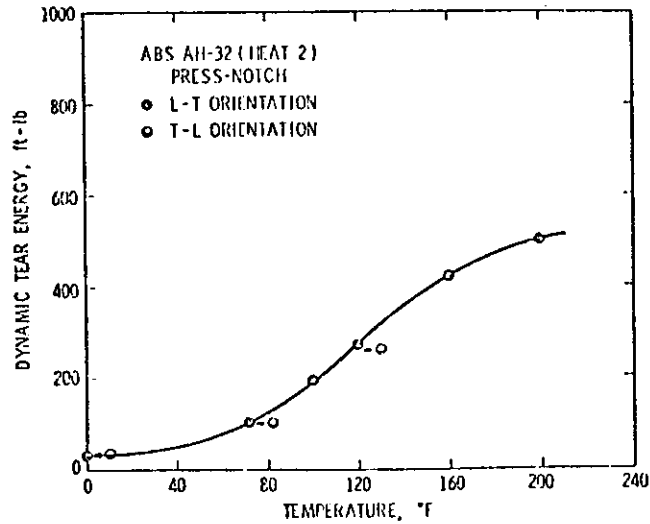

Figure 4.6 5/8" Parent DT, Press-Notch, AH-32 (Heat 2)

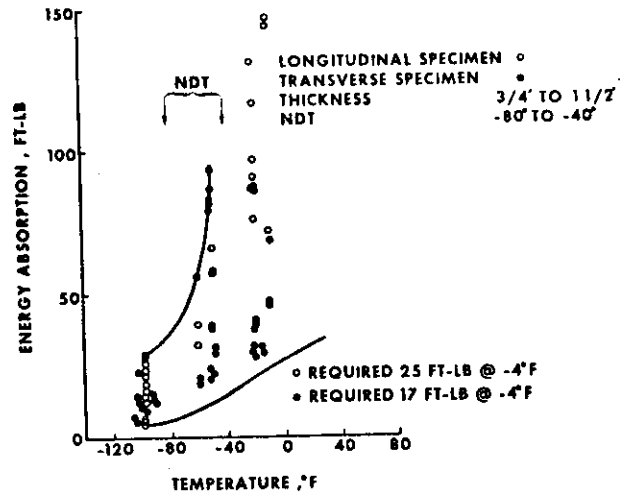

Figure 4.7 Charpy V-Notch Impact Test Curves for ABS-DH Steel

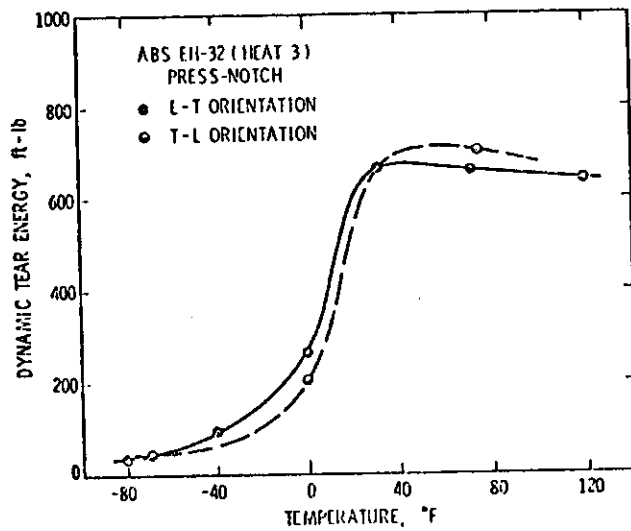

Figure 4.8 EH-32 (Heat 3), 5/8" Parent DT, Press-Notch

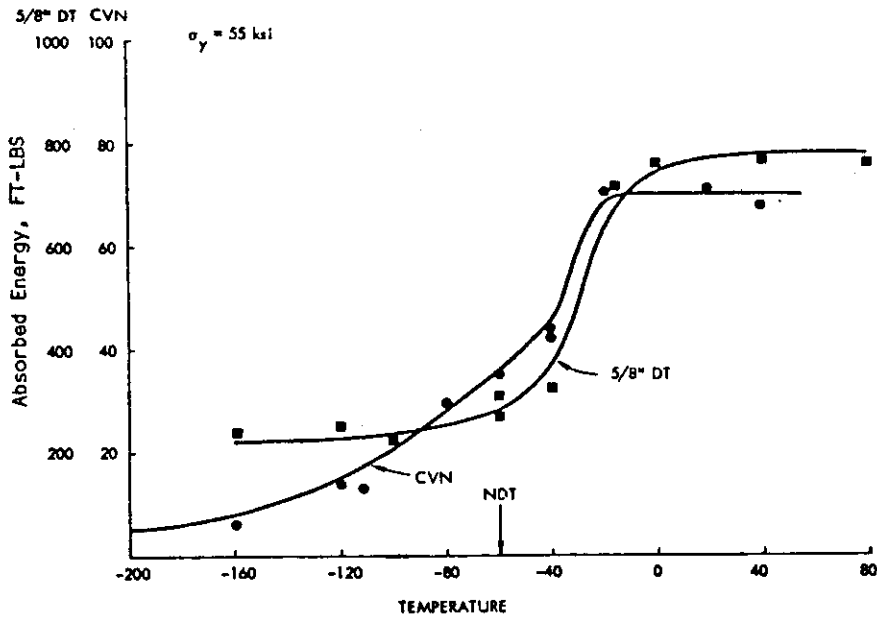

Figure 4.9 DT and CVN Test Results for 537A Steel
 $-\sigma_y = 55 \text{ ksi (379 MN/m}^2\text{)}$

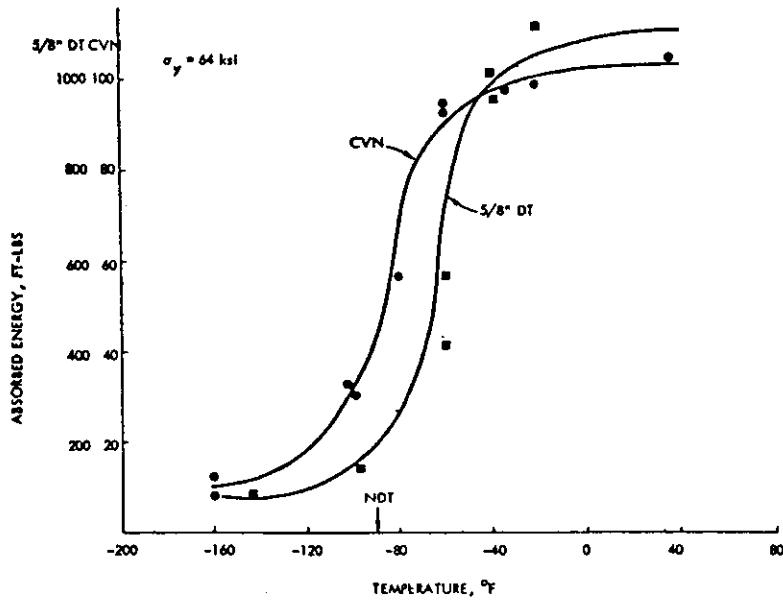

Figure 4.10 DT and CVN Test Results for A537B Steel
 $-\sigma_y = 64 \text{ ksi (441 MN/m}^2\text{)}$

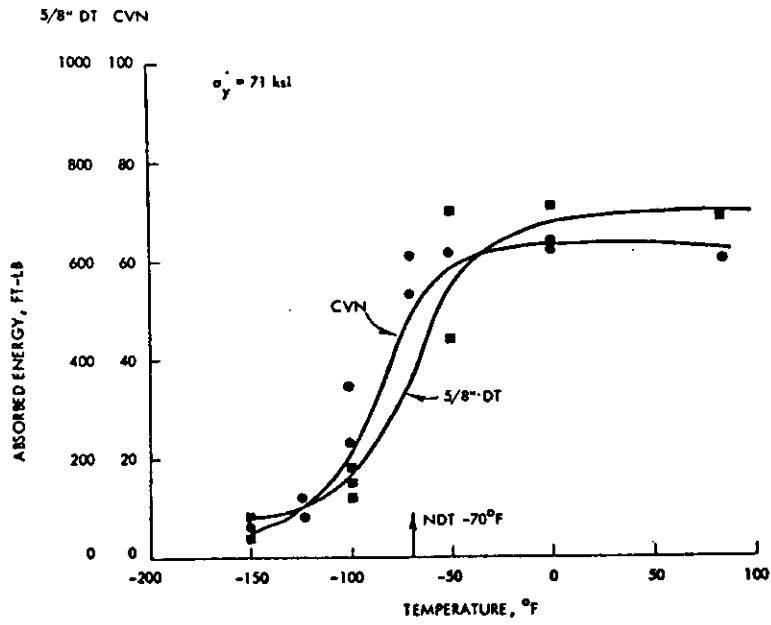

Figure 4.11 DT and CVN Test Results for A537B Steel
 $\sigma_y = 71 \text{ ksi}$ (490 MN/m^2)

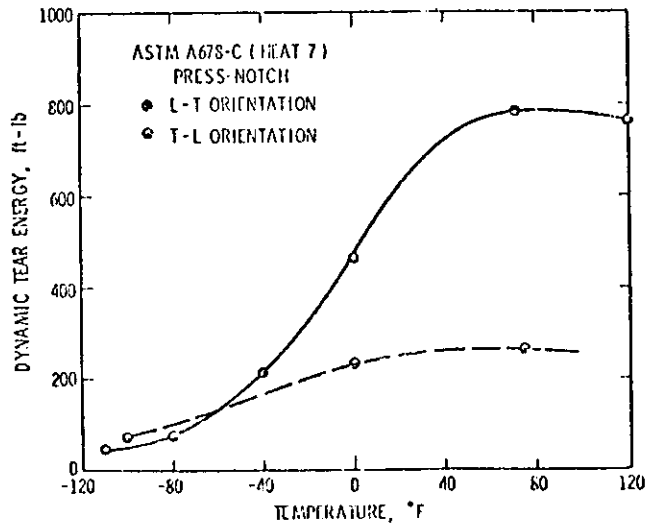

Figure 4.12 A678-C (Heat 7), 5/8" Parent DT,
 Press-Notch

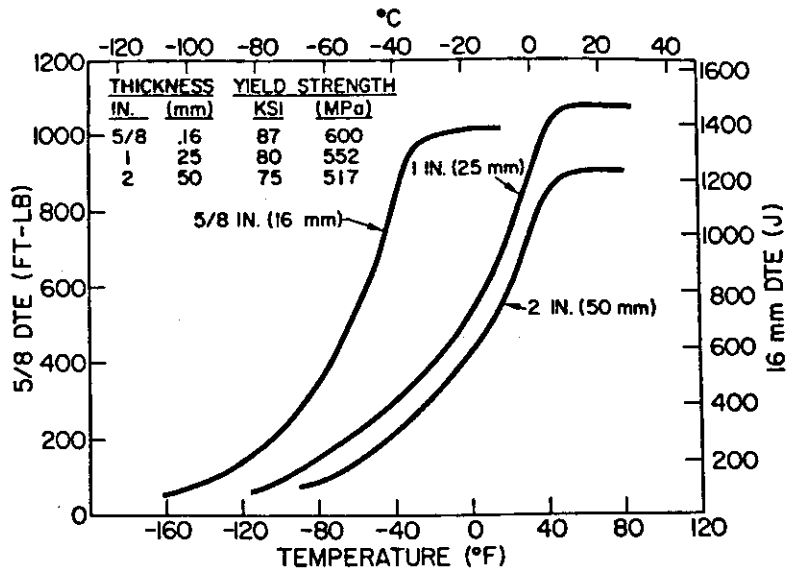

Figure 4.13 DT Test Results for ASTM A-710 Grade A Steel Plates

- Adequate Properties After Fabrication and Welding: The selected steels must have the ability to recover their original strength and toughness properties at normal and low temperatures in the base metal, heat-affected zone, and weld without sharp increases in fabrication and welding costs.

Of these properties, the most critical for a material at low temperatures and under repeated high stress in a ship is the resistance against brittle fracture. There are three primary factors that need to be present for brittle fracture to occur.

- High Stresses. The magnitude of stress for a given location in the hull depends on the static and dynamic loading, on built-in, residual welding stresses, and on the quality of the structural arrangement and detail design with respect to crack-initiating discontinuities.
- Material Toughness. The toughness of the material in a structure is controlled by its chemical composition, by the heat treatment during its production, by the applied fabrication and welding techniques during construction, and by the operating temperatures of the vessel.
- Material Flaw Size. The structures in a ship have many initial flaws or hair cracks in the base material or in the way of welds for various reasons. These cannot be avoided in spite of careful design practices and stringent quality inspection. These flaws have to be prevented from growing to a critical size with the correct choice of steel.

4.2 Currently Available Steels

4.2.1 Description of Tables

A number of materials currently used throughout the industry in the construction of ice strengthened ships have been compiled in Table B-3.1, Appendix B-3 of Volume II. This includes the ice strengthening of vessels operating in the Baltic Sea, in Arctic waters, and on the Great Lakes. Table B-3.1 gives the material designation and the specification source, such as classification society rules, and specifications of built vessels and proposed vessels; it also includes the area of material application within the ship's hull, such as the ice belt, shell, weather decks, superstructure, etc. Abbreviations used in this table and in other tables in Appendix B-3 are as follows:

MS	= Mild steel
HTS	= Higher strength steel
ASTM	= American Society for Testing and Materials
USCG	= United States Coast Guard
ABS	= American Bureau of Shipping
LR	= Lloyd's Register of Shipping (British)
DNV	= Det norske Veritas (Norwegian)
BV	= Bureau Veritas (French)
NKK	= Nippon Kaiji Kyokoi (Japanese)
GL	= Germanischer Lloyd (German)

Information on a number of additional steels suitable for the ice-strengthening of ships has been gathered and listed in Table B-3.2 of Appendix B-3. These steels are proposed mainly for ships designed for Arctic or Antarctic service. The table also gives the suggested area of application. Many of the above proposed materials were originally developed by the steel industry for low-temperature pressure vessel applications, low-temperature structural components of LNG and LPG carriers, and cold-region offshore structures. Therefore, they should be suitable for ice-strengthening of ships as well.

The chemical and physical properties as well as fabrication techniques are compared in tabular form in Table B-3.3 of Appendix B-3. The materials are the currently used, or specified, steels for ice strengthening, and also the steels proposed in Table B-3.2. All materials listed in Table B-3.3 have been organized by a relative cost factor. This cost factor was determined for each material based on January 1980 market prices using ABS mild steel Grade A as the comparison basis, with a cost factor of 1.0.

The following properties and information have been compiled in Table B-3.3 using metric units, as applicable, with English units in parentheses:

- Process of manufacture
- Deoxidation method
- Type of heat treatment
- Chemical material composition
- Ultimate tensile strength and yield point
- Minimum elongation of the material
- Charpy V-notch impact test results
- NDT (nil-ductility transition) temperature
- Dynamic tear energy test results
- Abrasion resistance in the form of Brinell hardness
- Required welding and fabrication techniques
- Relative cost factor based on ABS Grade A.

The sources for the material data produced in Tables B-3.1, B-3.2, and B-3.3 consist of the information given in the material sections of the various classification societies, specifications of USCG and commercial ice strengthened vessels, steel manufacturers material specifications, and ASTM specifications. Most of the additional steels proposed in this report for the ice strengthening of ships were recommended by the various steel producers who had been contacted for this purpose.

The information with respect to welding and fabrication techniques was verified by welding and fabrication specialists from a shipyard. The relative cost factors for the steels were provided by cost engineers using current prices of the steel producers.

4.2.2 General Discussion of Steels Available for Low-Temperature Applications

A number of mild and higher strength steels are given in the structural material section of classification society rules which are available for

ice strengthened ships. Materials included in this report are extracted from the following society rules:

- American Bureau of Shipping
- Lloyd's Register of Shipping (British)
- Det norske Veritas (Norwegian)
- Bureau Veritas (French)
- Nippon Kaiji Kyokai (Japanese)
- Germanischer Lloyd (German).

These steels are satisfactory for all areas of ship's hull for service in the Northern Baltic Sea and the Great Lakes, but only for certain areas of the hull in Arctic waters. If it comes to relatively low temperatures in conjunction with high pressures or impact loads, most classification society steels are not usable due to their insufficient ductility at low temperatures.

The U.S. Coast Guard developed a steel specification, CG-A537M, for their Polar Class icebreakers, which has the qualities required for Arctic service together with acceptable cost and good weldability.

Two steels, according to military specifications, are included in Table B-3.3--HY-80 and HY-100. Those two steels satisfy the most stringent requirements for Arctic service, but are relatively expensive and difficult to fabricate.

There are a number of steels available to ASTM specifications which are suitable for Arctic service and favorable with regard to cost and producibility. These steels are more familiar to the industry under their commercial trade names. No preference is given for a particular steel of this category in this report.

4.2.3 Range of Properties

The range of the more significant physical properties of the steels incorporated in Table B-3.3 are indicated below. Of course, some of the properties will vary for a particular material depending on the thickness.

The yield stresses vary from 34 KSI (24 kg/mm²) for mild steels covered by the classification society to 100 KSI (70 kg/mm²) for HY-100 steels.

The Charpy V-notch impact test results range for longitudinal specimens from 20 ft-lb (2.8 kg-m) at 32°F (0°C) to 50 ft-lb (6.9 kg-m) at -119°F (-84°C) and for transverse specimens from 14 ft-lb (2.0 kg-m) at 32°F (0°C) to 50 ft-lb (6.9 kg-m) at -119°F (-84°C). For some of the mild or higher strength steels, Charpy V-notch impact tests are not required. In a few exceptional cases, the required energy values are lower than indicated above, but the test temperatures are lower as well; see ASTM-A678 Gr. B and ASTM-A537 Class 2, for instance.

The NDT (nil-ductility transition) temperatures were not available for the majority of steels. The temperatures which were obtained varied between +50°F (+10°C) and -161°F (-107°C).

The dynamic tear energy test results range from 101 ft-lb (14 kg-m) to 1012 ft-lb (140 kg-m) at 75°F (24°C), but are not available for most of the materials.

The abrasion resistance of the steels, given in the form of Brinell hardness, is closely related to the ultimate strength of a material. The Brinell hardness for the steels in Table B-3.3 starts with a value of 110 for the mild steels and goes up to 233 for the strongest material listed in the table, which is HY-100.

4.2.4 Range of Required Special Fabrication Techniques

The ordinary mild steels given in Table B-3.3 do not require any special welding or fabrication techniques. Moderate preheating of the base material and low-hydrogen practice for the welding process is required for the higher strength steels of the classification societies. This applies also to the USCG steel CG-A537 M and to all ASTM steels, except those discussed below. In addition to preheating and low-hydrogen practice, special electrodes are required for ABS low-temperature steels Gr. V-039 and V-05, ASTM steels A678 Gr. C and A710 Gr. A Class 3, and Military Spec. steels HY-80 and HY-100. Normal forming and cutting practice may be used for all steels listed in Table B-3.3, except for HY-80 and HY-100, which require additional forming power and special precautions during flame cutting.

The impact on construction costs for limited preheating and low-hydrogen practice is moderate. On the other hand, the cost for careful control of the whole welding process and the use of special electrodes, as required for some steels, could be high enough to make certain steels infeasible for ship construction. This is especially true if the material purchase price is very high and, in addition, special fabrication techniques are to be employed.

4.2.5 Range of Steel Costs

A relative cost factor was established for each material in Table B-3.3, as indicated above. The cost factors, with ABS Grade A as the basis, range from 1.0 for mild steel to 3.23 for special high-strength steels requiring careful production control, costly heat treatment, and extensive testing. High-quality steels are available for Arctic service for a price increase of only 46 to 52% above the ordinary mild steel prices, as can be seen in Table B-3.3.

4.3 Existing Criteria for Material Selection

A study was made with respect to existing criteria which a ship designer could use in the material selection for the hull structure of ice strengthened ships. The rule sections dealing with the strengthening for navigation in ice of the following classification societies and regulatory bodies were investigated:

- American Bureau of Shipping
- Lloyd's Register of Shipping
- Det norske Veritas

- Bureau Veritas
- Nippon Kaiji Kyokai
- Germanisscher Lloyd
- Registro Italiano Navale
- Canadian Arctic Pollution Prevention Regulations
- Finnish-Swedish Ice Class Rules

The above classification societies and regulatory bodies specify required minimum plate thicknesses, section moduli, and ice pressures on the ship's hull. Only one of the classification societies and regulatory bodies, the Germanisscher Lloyd, specifies criteria pertaining to design temperatures in Arctic waters for material selection purposes. None of the classification societies and regulatory bodies provide toughness criteria for low service temperatures on steels.

This fact does not present too much of a problem for the Northern Baltic Sea or the Great Lakes, since classification society steels are probably satisfactory for those areas. For the Arctic and Antarctic, however, there is a deficiency in the failure to specify materials criteria.

The following suggested criteria are based on those already in use by classification societies for low-temperature materials for ships carrying liquified gases in bulk:

- Establish Environmental Service temperatures based on specific Arctic or Antarctic regions.
- Apply the Environmental Service temperatures to hull steels from 5 ft below the lowest waterline up, and throughout the deck for all steels exposed to the air.
- Base temperatures for Interior Service on heat transfer calculations.

The toughness criteria of ABS Section 24.55 [C-13] and USCG Marine Engineering Regulations Subchapter F are to be applied at a test temperature of at least 10°F (-12°C) below the service temperatures defined above.

4.4 Requirements for Additional Information

In the process of gathering the data on materials from the various sources for this report, it became apparent that very limited published and non-proprietary information is available on the toughness performance of steels, as can be seen in Table B-3.3. This is especially true for data to be given over a range of lower temperatures. A similar lack of published information exists in the area of fatigue properties for lower temperatures. Most published S-N curves for steels are based on tests at room temperature.

5. EXISTING ICE STRENGTHENING CRITERIA

5.1 General Description of Existing Criteria

Ice strengthening criteria which have been reviewed include government regulations, classification society rules, currently employed design practices, and criteria which have been proposed in the literature. A list of these criteria and the classes within each is shown in Table 5.1. Although the criteria overlap in some cases, they are for the most part independent. Sources of information used in comparing these criteria include the regulations and rules themselves, the literature, and personal communication with cognizant individuals. The following paragraphs provide a brief description of each of the criteria listed in the table. Subsequent sections include comparisons of methodologies, resulting scantlings, and economics associated with these criteria.

Currently, the most comprehensive criteria available for the ice strengthening of ships are the Canadian "Arctic Shipping Pollution Prevention Regulations" [C-11]. In these regulations, which were issued by the Governor General in Council, required levels of ice strengthening for ships are specified as a function of geographic area of operation and time of year. The Canadian ASPPR includes 9 Arctic Classes and 5 Subarctic Types. The subarctic types are equivalent to various classification societies' classes as shown in Table 5.2

The Finnish-Swedish Ice Class Rules were issued by the Board of Navigation in 1971 to establish ice strengthening criteria for ships operating in the Baltic. These rules, which are based on analysis of ice damage to ships [B-16], have subsequently been adopted by a number of classification societies for classing ships which operate in the Baltic. A summary of identical or equivalent classification society classes is shown in Table 5.3. Strengthening requirements are specified for ice conditions ranging from "mild" to "extreme".

All major classification societies specify ice strengthening requirements for ice classed ships as illustrated in Table 5.1. Most of these societies have adopted the Finnish-Swedish Rules as part of their classification system. The American Bureau of Shipping [C-13], Lloyd's Register of Shipping [C-14], Bureau Veritas [C-15], and Nippon Kaiji Kyokai [C-16] assign ice classes based on the Finnish-Swedish Rules and their own parallel set of rules. Det norske Veritas [C-17] specifies three classes in addition to those of the Finnish-Swedish Rules; Registro Italiano Navale [C-18] and Germanischer Lloyd [C-19] specify classes based solely on the Finnish-Swedish Rules. The USSR Register of Shipping [C-20] and the Register of Shipping of the Peoples Republic of China [C-21] are the only societies that rely solely on their own rules.

Other ice strengthening criteria which have also been considered include U.S. Coast Guard Design Practice [D-21, D-22, D-23] and several theoretical and empirical methods proposed in the literature [B-16, B-23, B-26, B-38, D-3]. Although some of these works are not complete ice strengthening criteria and thus cannot be compared directly to regulations and classification society rules, analysis does provide insight into alternate load criteria and design methods.

5.2 Methods for Selecting the Level of Ice Strengthening

Current government regulations and classification society rules present a wide range of methods for selecting the level of ice strengthening. The Canadian

TABLE 5.1 LISTING OF CURRENT ICE STRENGTHENING CRITERIA

GOVERNMENT REGULATIONS

Canadian Arctic Shipping Pollution Prevention Regulations

Classes: 1, 1A, 2, 3, 4, 6, 7, 8, 10

Types: A, B, C, D, E

Finnish-Swedish Ice Class Rules

Classes: IA Super, IA, IB, IC, II, III

CLASSIFICATION SOCIETY RULES

American Bureau of Shipping

Classes: A, B, C, IAA, IA, IB, IC

Lloyd's Register of Shipping

Classes: 1*, 1, 2, 3, IA Super, IA, IB, IC, ICEBREAKER,

Det Norske Veritas

Classes: ICE IA*, ICE IA, ICE IB, ICE IC, ICE C, ICEBREAKER
ARCTIC ICEBREAKER

Bureau Veritas

Classes: Glace I-Super, Glace I, Glace II, Glace III, IA Super,
IA, IB, IC

Registro Italiano Navale

Classes: RG 1*, RG 1, RG 2, RG 3

Germanischer Lloyd

Classes: E, E1, E2, E3, E4

Nippon Kaiji Kyokai

Classes: AA, A, B, C, IA Super, IA, IB, IC

USSR Register of Shipping

Classes: YAA, YA, A1, A2, A3, A4

Register of Shipping of the Peoples Republic of China

Classes: BI*, BI, BII, BIII, B

CURRENT DESIGN PRACTICE AND OTHER PROPOSED CRITERIA

U.S. Coast Guard

Polar Icebreaker Design [D-21]

Great Lakes Icebreaker Design [D-22, D-23]

Method Proposed by Johansson [B-16]

Method of Popov et al. [B-38]

Method Proposed by Major et al. [B-26]

Method Proposed by Crighton [D-3]

Method Proposed by Levine [B-23]

TABLE 5.2 CLASSIFICATION SOCIETY REGULATIONS DEEMED EQUIVALENT TO CANADIAN ASPPR TYPES

Finnish-Swedish Class/ Classification Society	IA Super	IA	IB	IC	II
American Bureau of Shipping	IAA	IA, A ²	IB, B ²	IC, C ²	A1(E) ¹
Lloyd's Register of Shipping	IA Super, 1*	IA, 1	IB, 2	IC, 3	100 A1 ¹
Det Norske Veritas	IA	IA	IB	IC, ICE	1A1 ¹
Bureau Veritas	IA-Super, Glacc 1-Super ²	IA, Glacc 1 ²	IB, Glacc II ²	IC, Glacc III ²	I 3/3 E ¹
Registro Italiano Navale	RG 1*	RG 1	RG 2	RG 3	100A-1.1 ¹
Germanischer Lloyd	E4	E3	E2	E1	100A4 ¹
Nippon Kaiji Kyokai	IA Super ¹	IA ¹	IB ¹	IC ¹	NS ¹
USSR Register of Shipping	YAA, YA	A1	A2	A3, A4	A4, KM

1. Deemed to be equivalent.
2. For ships with designs approved prior to 1/5/71.

TABLE 5.3 CLASSIFICATION SOCIETY ICE CLASSES IDENTICAL OR EQUIVALENT TO FINNISH-SWEDISH REGULATIONS

Canadian ASPPR Type/ Classification Society	A	B	C	D	E
American Bureau of Shipping	IAA	IA	IB	IC	A1
Lloyd's Register of Shipping	1*	1	2	3	100A-1
Det Norske Veritas	ICE A*	ICE A	ICE B	ICE C	1A1
Bureau Veritas	ICE I Super	ICE I	ICE II	ICE III	I 3/3 E
Register Italiano Navale	RG 1*	RG 1	RG 2	RG 3	100A-1.1
Germanischer Lloyd	E4	E3	E2	E1	100A-4

Note: These equivalencies were published in 1972. Since that time other societies have adopted the Finnish-Swedish rules and should be included in the above table.

ASPPR specify ice classes required for operation in the Canadian Arctic by geographic area and time of year. However, most classification society rules leave selection of the level of strengthening completely up to the owner and some do not even give qualitative descriptions of ice conditions for the levels of ice strengthening. The following paragraphs discuss the guidelines (or requirements) specified by each of the regulations and classification society rules.

As stated previously, the Canadian Arctic Shipping Pollution Prevention Regulations require that ships be ice strengthened to a certain Class (or Type) in order to enter specified geographic areas during specified months. The division of the Canadian Arctic into 16 zones is shown in Figure 5.1. These zones are based on the types and thickness of ice encountered; the most severe ice conditions are found in zones with the lowest numbers. Table 5.4 illustrates the time periods when ships with different ice classes can enter these zones. As an example, an Arctic Class 10 ship can operate year-round anywhere in the Canadian Arctic, while a Type A ship which is equivalent to ABS IAA can only operate in 13 of the 16 zones for periods ranging from 1 to 5 months per year.

The Finnish-Swedish Ice Class Rules state that it is the responsibility of the owner to determine which ice class is most suitable for his intentions; however, the Board of Navigation does restrict shipping to and from specified ports in the winter. This is done by specifying the minimum ice classes which will be escorted to each location for certain time periods. These rules are more flexible than the Canadian rules in that the restrictions are based on observed and expected ice conditions during the year in question rather than on one set of typical ice conditions. The ice conditions are defined as extreme, severe, medium, and light and equate with classes IA Super, IA, IB, and IC, respectively.

The American Bureau of Shipping, Lloyds, Bureau Veritas, Registro Italiano Navale, and Nippon Kaiji Kyokai state that it is the responsibility of the owner to determine which ice class is most suitable for his intended service. Each of these rules define ice conditions which the different classes are intended for in general terms such as extreme, severe, moderate, and light. The American Bureau of Shipping, Lloyds, and Nippon Kaiji Kyokai define two parallel sets of classes, one set for general service and one set for operation in the Northern Baltic.

Germanischer Lloyd defines ice conditions for each class as described above, but does not specify how the proper ice class is to be selected. Det norske Veritas and the Register of the Peoples Republic of China do not attempt to describe ice conditions which the ice classes are intended for and do not specify a method for selecting an ice class. Only Lloyds and Det norske Veritas have classes for icebreakers. Lloyds describes the application of the class to ships engaged in icebreaking duties; Det norske Veritas does not define the application of the two classes, Icebreaker and Arctic Icebreaker.

5.3 Load Criteria, Rationale, and Structural Design Methods

Comparison of existing ice strengthening criteria requires that the methods used to specify structural requirements for alternate ice classes be analyzed. This analysis can be divided into two basic parts: (1) comparison of the loads which are assumed to act on the structure; and (2) comparison of the design methods used to specify structures suitable for those loads. Furthermore, analysis of the rationale and assumptions utilized in the development of the loads is necessary as a basis for formulation of an improved procedure for specifying ice strengthening criteria. Currently, no universally accepted procedure exists for estimating the

5-5

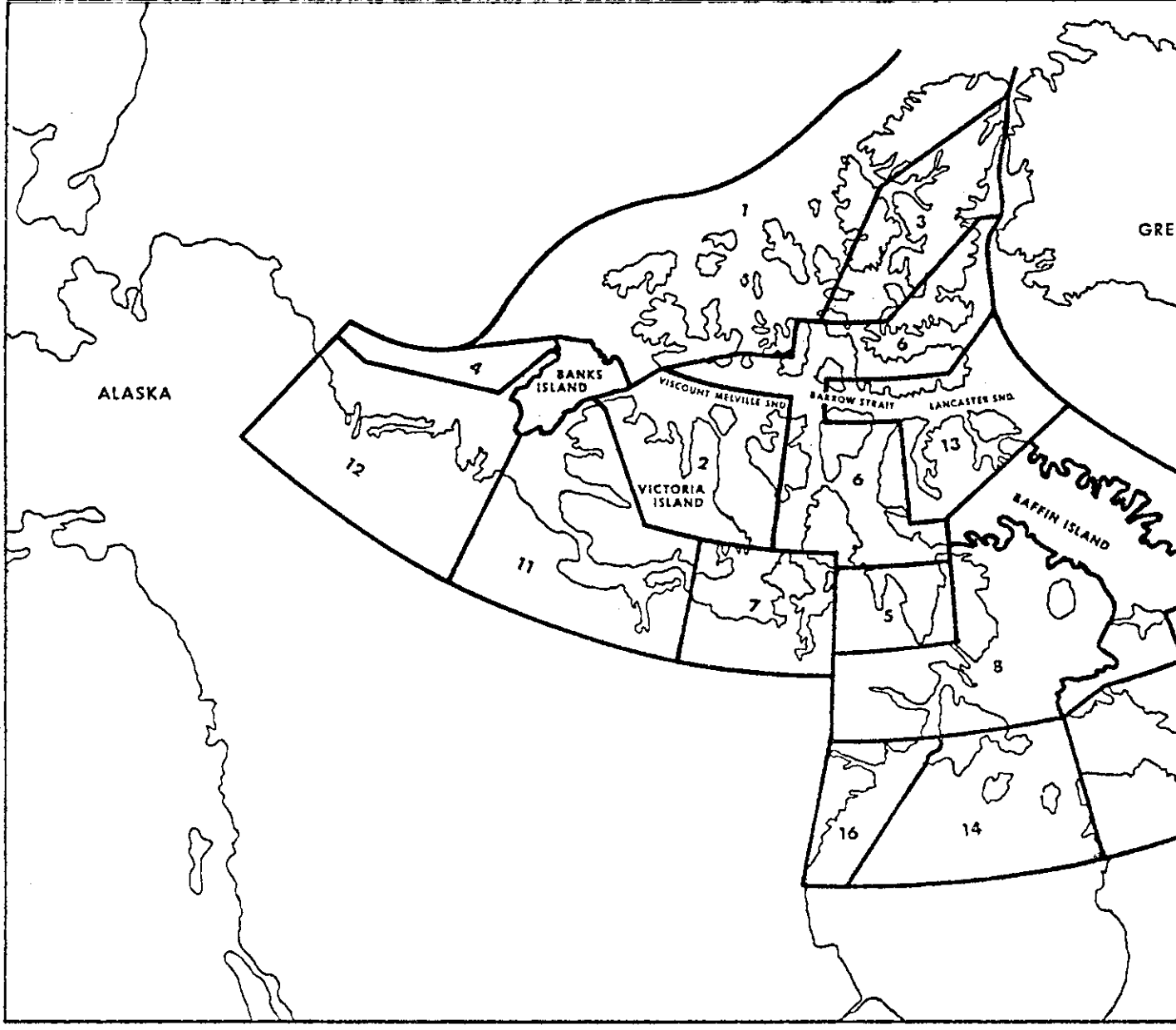

Figure 5.1. Arctic Pollution Prevention Control Zones

TABLE 5.4 CANADIAN RESTRICTIONS TO NAVIGATION BY CONTROL ZONE AND TIME OF YEAR [C-11]

Column I Category	Column II Zone 1	Column III Zone 2	Column IV Zone 3	Column V Zone 4	Column VI Zone 5	Column VII Zone 6	Column VIII Zone 7	Column IX Zone 8	Column X Zone 9	Column XI Zone 10	Column XII Zone 11	Column XIII Zone 12	Column XIV Zone 13
Arctic Class 10 1.	All Year	All Year	All Year	All Year	All Year	All Year	All Year	All Year	All Year	All Year	All Year	All Year	All Year
Arctic Class 8 2.	Jul. 1 to Oct. 15	All Year	All Year	All Year	All Year	All Year	All Year	All Year	All Year	All Year	All Year	All Year	All Year
Arctic Class 7 3.	Aug. 1 to Sept. 30	Aug. 1 to Nov. 30	Jul. 1 to Dec. 31	Jul. 1 to Dec. 15	Jul. 1 to Dec. 15	All Year	All Year	All Year	All Year	All Year	All Year	All Year	All Year
Arctic Class 6 4.	Aug. 15 to Sept. 15	Aug. 1 to Oct. 31	Jul. 15 to Nov. 30	Jul. 15 to Nov. 30	Aug. 1 to Oct. 15	Jul. 15 to Feb. 28	Jul. 1 to Mar. 31	Jul. 1 to Mar. 31	All Year	All Year	Jul. 1 to Mar. 31	All Year	All Year
Arctic Class 4 5.	Aug. 15 to Sept. 15	Aug. 15 to Oct. 15	Jul. 15 to Oct. 31	Jul. 15 to Nov. 15	Aug. 15 to Sept. 30	Jul. 20 to Dec. 31	Jul. 15 to Jan. 15	Jul. 15 to Jan. 15	Jul. 10 to Mar. 31	Jul. 10 to Feb. 28	Jul. 5 to Jan. 15	June 1 to Jan. 31	June 1 to Feb. 15
Arctic Class 3 6.	Aug. 20 to Sept. 15	Aug. 20 to Sept. 30	Jul. 25 to Oct. 15	Jul. 20 to Nov. 5	Aug. 20 to Sept. 25	Aug. 1 to Nov. 20	Jul. 20 to Dec. 15	Jul. 20 to Dec. 31	Jul. 20 to Jan. 20	Jul. 15 to Jan. 25	Jul. 5 to Dec. 15	June 10 to Dec. 31	June 10 to Dec. 31
Arctic Class 2 7.	No Entry	No Entry	Aug. 15 to Sept. 30	Aug. 1 to Oct. 31	No Entry	Aug. 15 to Nov. 20	Aug. 1 to Nov. 20	Aug. 1 to Nov. 30	Aug. 1 to Dec. 20	Jul. 25 to Dec. 20	Jul. 10 to Nov. 20	June 15 to Dec. 5	June 25 to Nov. 15
Arctic Class 1A 8.	No Entry	No Entry	Aug. 20 to Sept. 15	Aug. 20 to Sept. 30	No Entry	Aug. 25 to Oct. 31	Aug. 10 to Nov. 5	Aug. 10 to Nov. 20	Aug. 10 to Dec. 10	Aug. 1 to Dec. 10	Jul. 15 to Nov. 10	Jul. 1 to Nov. 10	Jul. 15 to Oct. 31
Arctic Class 1 9.	No Entry	No Entry	No Entry	No Entry	No Entry	Aug. 25 to Sept. 30	Aug. 10 to Oct. 15	Aug. 10 to Oct. 31	Aug. 10 to Oct. 31	Aug. 1 to Oct. 31	Jul. 15 to Oct. 20	Jul. 1 to Oct. 31	Jul. 15 to Oct. 15
Type A 10.	No Entry	No Entry	Aug. 20 to Sept. 10	Aug. 20 to Sept. 20	No Entry	Aug. 15 to Oct. 15	Aug. 1 to Oct. 25	Aug. 1 to Nov. 10	Aug. 1 to Nov. 20	Jul. 25 to Nov. 20	Jul. 10 to Oct. 31	June 15 to Nov. 10	June 25 to Oct. 22
Type B 11.	No Entry	No Entry	Aug. 20 to Sept. 5	Aug. 20 to Sept. 15	No Entry	Aug. 25 to Sept. 30	Aug. 10 to Oct. 15	Aug. 10 to Oct. 31	Aug. 10 to Oct. 31	Aug. 1 to Oct. 31	Jul. 15 to Oct. 20	Jul. 1 to Oct. 25	Jul. 15 to Oct. 15
Type C 12.	No Entry	No Entry	No Entry	No Entry	No Entry	Aug. 25 to Sept. 25	Aug. 10 to Oct. 10	Aug. 10 to Oct. 25	Aug. 10 to Oct. 25	Aug. 1 to Oct. 25	Jul. 15 to Oct. 15	Jul. 1 to Oct. 25	Jul. 15 to Oct. 10
Type D 13.	No Entry	No Entry	No Entry	No Entry	No Entry	No Entry	Aug. 10 to Oct. 5	Aug. 15 to Oct. 20	Aug. 15 to Oct. 20	Aug. 5 to Oct. 20	Jul. 15 to Oct. 10	Jul. 1 to Oct. 20	Jul. 30 to Sep. 30
Type E 14.	No Entry	No Entry	No Entry	No Entry	No Entry	No Entry	Aug. 10 to Sept. 30	Aug. 20 to Oct. 20	Aug. 20 to Oct. 15	Aug. 10 to Oct. 20	Jul. 15 to Sept. 30	Jul. 1 to Oct. 20	Aug. 15 to Sept. 20

5-6

ice loads acting on a ship's hull. The following paragraphs describe load criteria, rationale, and structural design methods utilized by each of the ice strengthening criteria. Where similarities exist, these criteria are considered as a group.

5.3.1 Criteria Which Specify Percentage Increase in Rule Scantlings

The first category of criteria considered is that which specifies scantlings for operation in ice by increasing normal rule scantlings by a given percentage. Classification society rules which utilize this method are shown in Table 5.5 along with the specified scantling increases. This procedure assumes implicitly that ice loads are related to longitudinal and transverse strength requirements and hydrostatic loads. As is the case with most classification society ice rules, increased scantlings are specified for an ice belt divided into forward, midbody and aft sections with vertical extent exceeding the range of operating waterlines by a fixed value. As shown in Table 5.5, the specified percentage increases in scantlings vary greatly from rule to rule. The only two sets of rules which are approximately equivalent are Bureau Veritas and the Register of the Peoples Republic of China.

5.3.2 Canadian ASPPR

These regulations specify the ice loads in the form of pressures which are used to design shell plating and frames. The division of a ship's hull into six areas for application of these pressures is shown in Figure 5.2. The loads range from 100 psi to 1500 psi as shown in Table 5.6. Since these regulations specify area of operation for alternate ice classes as a function of time of year, the pressures listed in Table 5.6 must be based on an estimation of the maximum ice pressure which might be encountered in a given type of ice. The procedure used for estimating these pressures is not known exactly; however, the zoning of the geographic Arctic regions into ice zones was due mainly to average level ice conditions at different times of the year. *Ice thickness* and intensity were the main criteria in characterizing geographic divisions with implied homogenous level ice conditions in an average year. In effect, the ice thickness in each zone was used as a basis to allow entry of ships with specified ice classifications. For instance, an Arctic Class 3 ship will be allowed to enter zones *where* and *when* ice thickness does not exceed 3 feet. Consequently, the class of a ship is the same as the maximum level ice capability of that ship. No distinction is made between different types of ice and, accordingly, the ice pressures specified in the rules seem to vary in a rather linear fashion with increasing class of the ship (implying linear correlation with ice thickness). Figure 5.3 illustrates the observed linearity between the ice pressure and ship class. The significant variation of pressure at different segments of the hull reflects the degree of detail in the selection of pressure criteria.

The levels of ice pressure were selected on the basis of then existing data, e.g. Johansson's work on the ice-strengthening of ship hulls [B-16]. These data resulted from an analysis of damage to ships operating in regions which differ significantly from the Canadian Arctic, e.g. the Baltic Sea. This necessitated some extrapolation to estimate the relevant pressure level. The documentation and rationale of the procedures used were not published and it is difficult to establish, at the present time, how the rule values were derived.

TABLE 5.5 ICE STRENGTHENING CRITERIA WHICH SPECIFY SCANTLINGS BY INCREASING NORMAL RULE SCANTLINGS

Society	Class	PERCENTAGE INCREASE IN SCANTLINGS								
		Plating* Increase	BOW		Plating* Increase	MIDBODY		Plating* Increase	STERN	
			Frame S.M. Increase	Frame Spacing Decrease		Frame S.M. Increase	Frame Spacing Decrease		Frame S.M. Increase	Frame Spacing Decrease
ABS	A	50%	To Midship	50%	25%	None	50%	25%	To Midship	50%
	B	50%	To Midship	50%	50-15%	None	None	15%	To Midship	None
	C	25%	To Midship	50%	None	None	None	None	To Midship	None
Bureau Veritas	Glacé I-Super	80%	100%	50%	40%	None	50%	25%	100%	50%
	Glacé I	50%	100%	50%	20%	None	50%	20%	100%	50%
	Glacé II	50%	None	50%	15%	None	None	15%	None	None
	Glacé III	25%	None	50%	None	None	None	None	None	None
Germanischer Lloyd	E	25%	None	40%	None	None	None	None	None	None
USSR Register	A2	50%	20%	50%	15%	None	None	15%	20%	None
	A3	25%	20%	50%	None	None	None	None	20%	None
	A4	25%	None	40%	None	None	None	None	None	None
Peoples Republic of China	BI*	80%	100%	50%	40%	None	50%	25%	100%	50%
	BI	50%	100%	50%	20%	None	50%	20%	100%	50%
	BII	40%	100%	50%	10%	None	None	10%	None	None
	BIII	25%	None	50%	None	None	None	None	None	None

*Increase above midship rule thickness

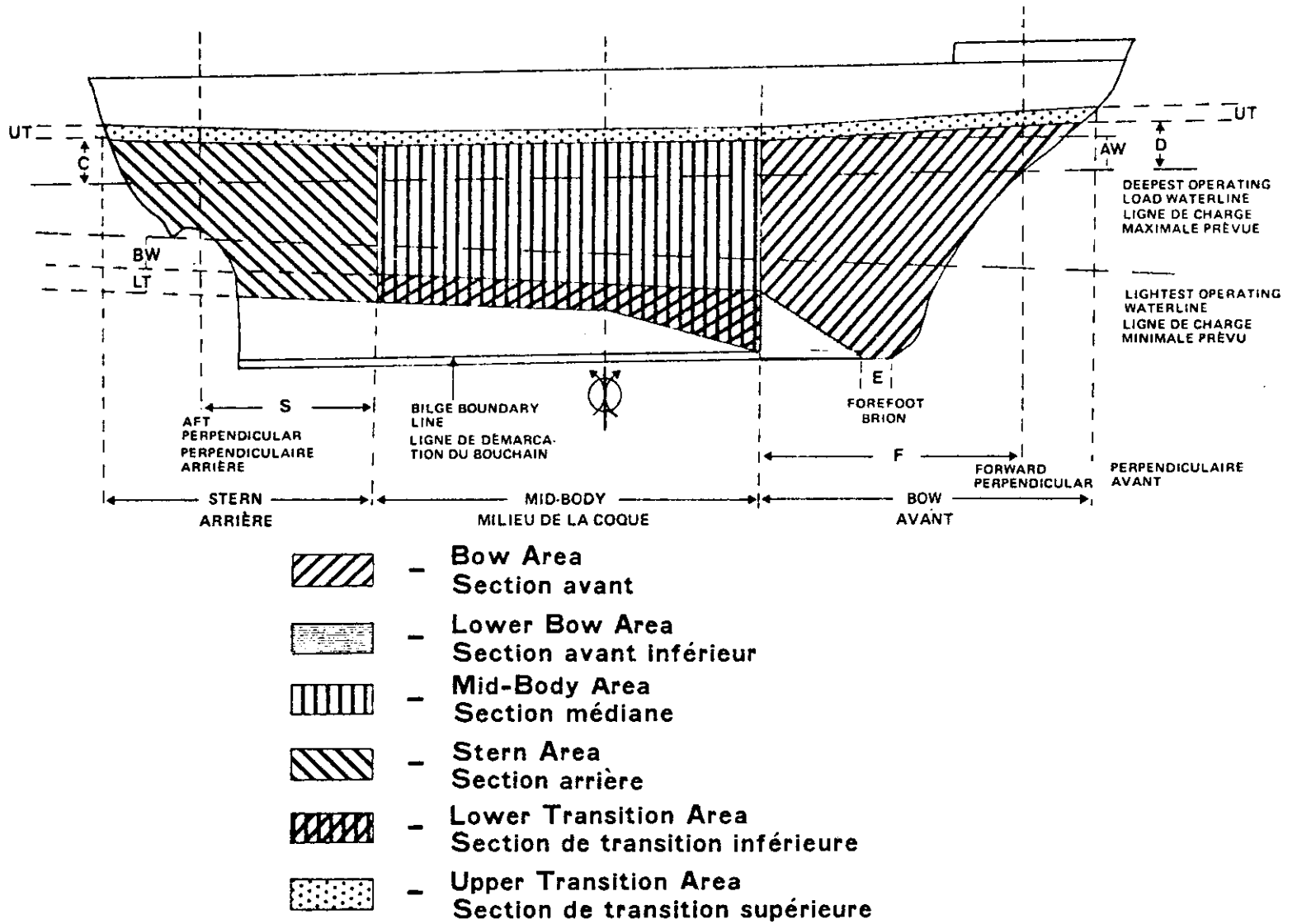

Figure 5.2 Canadian ASPPR Hull Areas for Ice Strengthening [C-11]

TABLE 5.6 ICE PRESSURES USED BY THE CANADIAN ARCTIC SHIPPING POLLUTION PREVENTION REGULATIONS [C-11]

Ice Pressures in pounds per square inch (kiloponds per square centimetre)							
	Column I	Column II	Column III	Column IV	Column V	Column VI	Column VII
Item	Arctic Class	Bow Area	Lower Bow Area	Mid-body Area	Lower Transition Area	Upper Transition Area	Stern Area
1	1	250* (17.58)	**	100* (7.03)	**	**	100* (7.03)
2	1A	400 (28.12)	210 (14.76)	260 (18.28)	180 (12.65)	130 (9.14)	325 (22.85)
3	2	600 (42.18)	320 (22.50)	400 (28.12)	260 (18.28)	200 (14.06)	500 (35.15)
4	3	800 (56.24)	420 (29.53)	530 (37.26)	370 (26.01)	260 (18.28)	660 (46.40)
5	4	1000 (70.30)	530 (37.26)	660 (46.40)	460 (32.34)	330 (23.20)	820 (57.65)
6	6	1200 (84.36)	640 (44.99)	750 (52.73)	520 (36.56)	370 (26.01)	940 (66.08)
7	7	1400 (98.42)	740 (52.02)	850 (59.76)	600 (42.18)	420 (29.53)	1050 (73.82)
8	8	1500 (105.65)	800 (56.24)	950 (66.79)	660 (46.40)	470 (33.04)	1200 (84.36)
9	10	1500 (105.65)	800 (56.24)	950 (66.79)	660 (46.40)	470 (33.04)	1200 (84.36)

*In an Arctic Class 1 ship, only that part of
 (a) the bow area and stern area lying between the horizontal projections of the upper and lower edges of the mid-body area need be considered; and
 (b) the mid-body area forward of amidships need be considered.
 **In an Arctic Class 1 ship, ice pressure need not be considered as a factor in the design of the hull in the lower bow area, lower transition area and upper transition area, and the strength standards usually applied to ocean-going ships shall apply in these areas.

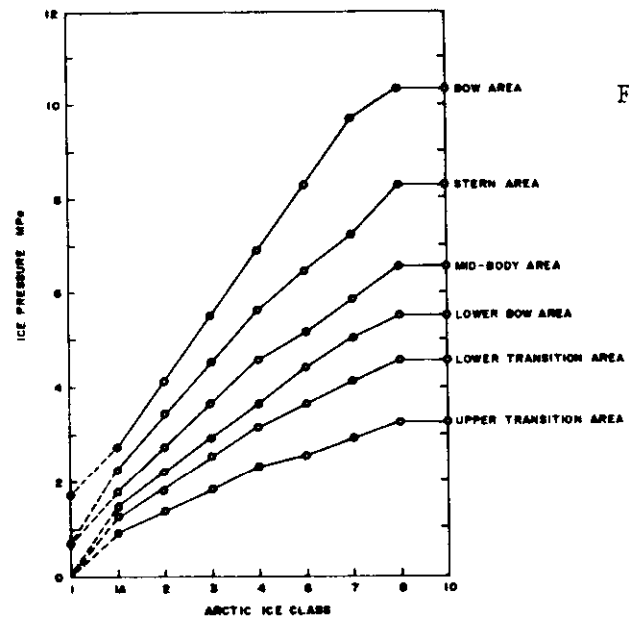

Figure 5.3 ASPPR Rule Ice Pressure vs. Arctic Class of Ship

Design of scantlings to withstand the loads discussed above is accomplished using plastic analysis methods. Shell plating thickness is specified by the formula:

$$t = S \left[\frac{2\sqrt{P}}{3f} \right] \quad (5.1)$$

where t = thickness
 S = frame spacing (selected by designer)
 P = design pressure from Table 5.7
 f = yield stress of the plating

This equation is similar to

$$t = \frac{S\sqrt{P}}{2f} \quad (5.2)$$

multiplied by a factor of safety of 1.5. Equation (5.2) is based on the development of 3 plastic hinges in a fixed-fixed beam subject to a uniform load. The section modulus of the main transverse frame is specified by the equation

$$S.M. = \frac{PS(b - 400)}{8f} \quad (5.3)$$

where $S.M.$ = section modulus
 P = design pressure from Table 5.7 [kp/cm]
 S = frame spacing [mm]
 b = span of the frame [mm]
 f = yield stress of the frame material [kp/cm²]

Equation (5.3) is similar to the following equation which calculates the section modulus required to just prevent development of plastic hinges when a uniform load 800 mm long is applied at mid-span, multiplied by a factor of safety of 1.25.

$$S.M. = \frac{PS(b - 400)}{10f} \quad (5.4)$$

In summary, the ASPPR design scantlings to the specified load by calculating the scantling which would barely withstand the load without development of plastic hinges and then multiplying by a factor of safety of 1.5 for plating and 1.25 for framing. For plating the load is assumed to be uniform over the entire area and for framing the load is assumed to be uniform for a 800 mm load acting at mid-span.

5.3.3 Finnish-Swedish Ice Class Rules

These rules are based in part on the work of Johansson [B-16]. The following paragraphs describe his work and the resulting set of ice strengthening criteria as adopted by the Finnish-Swedish Ice Class Rules and subsequently by the classification societies identified in Section 5.1.

The load criteria proposed by Johansson specifies design pressures as a function of $\sqrt{\text{Displacement } (\Delta) \times \text{Shaft Horsepower (SHP)}}$ for three regions of the ice belt, bow, midbody, and aft. The rationale for this approach is that a larger, more powerful ship is more likely to encounter stronger ice. In order to quantify the

relationships between ice pressure, displacement, and horsepower, over 200 cases of ice damage in the Baltic were analyzed and plots similar to that shown in Figure 5.4 were developed for each ice class. The proposed design lines were arbitrarily drawn so that "most of the damaged ships are beneath the design pressure, but not necessarily all". The maximum required design pressure (for the bow region of Class 1A Super) is specified as 30 kg/cm² (427 psi). This is assumed to be a reasonable value for the crushing strength of ice.

The Finnish-Swedish Ice Class Rules accept the rationale of Johansson that design pressure should be a function of $\sqrt{\Delta \times \text{SHP}}$, however, the design pressure lines used in the rules are well below those proposed by Johansson. A comparison of design pressures for Class 1A Super is shown in Figure 5.5. Although the rationale for the rule design lines is not known in detail, the selection of design lines based on analysis of damage data is arbitrary and apparently the Finnish-Swedish Navigation Board was not as conservative as Johansson. As shown in Figure 5.4, the Finnish-Swedish Ice Class Rules accept a higher number of historical failures above the design line than does the analysis by Johansson.

The structural design methods incorporated in the Finnish-Swedish Rules are similar to those discussed previously for the Canadian ASPPR. For transverse framing the design methods are identical. A section modulus of 1.25 times that which would just prevent development of plastic hinges when a uniform load of the specified pressure is applied over 800 mm at mid-span is required. For plating thickness, the design methods are identical with the exception that the Finnish-Swedish Rules modify the design pressure when applying it to plating, and a 2 mm corrosion allowance is required. Thus

$$t = \frac{2S}{3} \sqrt{\frac{P_3}{\sigma_y}} + 2 \text{ mm} \quad (5.5)$$

where t = thickness of plating
 S = frame spacing
 $P_3 = 1.2 P (1.1 - S/3,000)$
 P = design pressure
 σ_y = yield stress of the steel

The factor $(1.1 - S/3,000)$ is a correction for the load distributing effects of frame spacing and the factor 1.2 is a correction to increase design plating pressure to account for locally high impact pressures.

5.3.4 USSR Register of Shipping

Ice strengthening criteria specified by the USSR Register of Shipping for the Classes YA and A1 are similar to the criteria proposed by Popov et al [B-38] in that the ice loads acting on the ship are calculated for each case. Unlike the Canadian rules which specify constant pressures and the Finnish-Swedish Rules which specify pressures based on horsepower and displacement, the Russian rules calculate ice pressures as functions of ship length and bow shape (i.e. hull angles).

Popov et al [B-38] state that design loads at the bow should be calculated based on the impact loads experienced when a ship collides with an ice floe and provide a theoretical method for calculating these loads from hull shape and size. The following equation, which is used in the Russian rules, is a simplification of the load-predicting relationship given in [B-38].

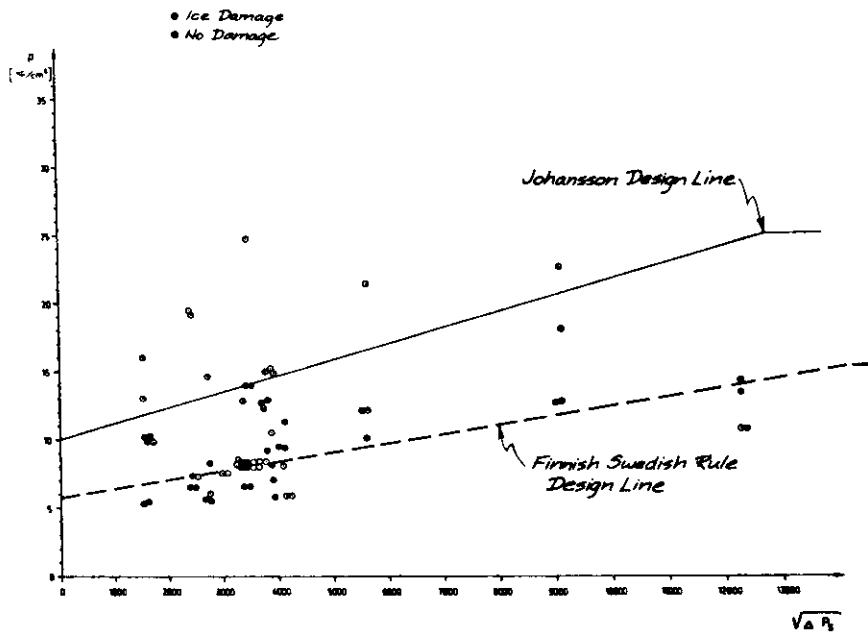

Figure 5.4 Example of Damage Analysis Conducted by Johansson from Ref. [B-16]

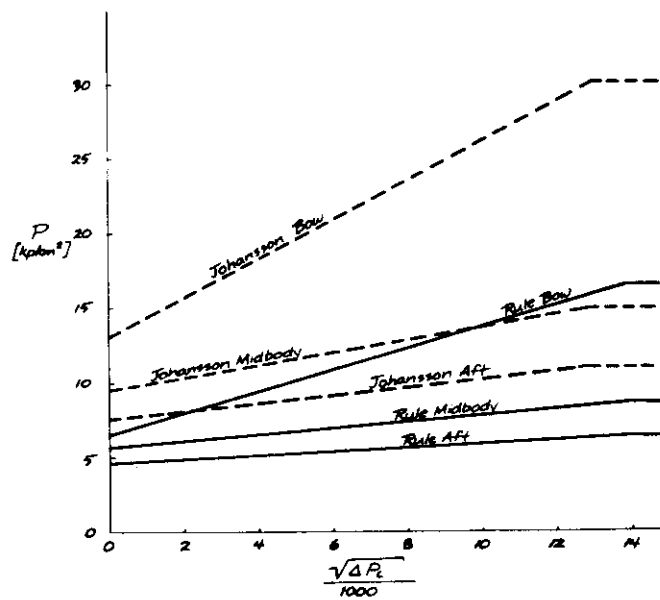

Figure 5.5 Comparison of Framing Design Ice Pressures Specified by Johansson [B-16] with Those Specified by the Finnish - Swedish Ice Class Rules [C-12]

$$P = AL \left(1 + \frac{2L}{1,000} \right) \alpha^{4/5} \mu \quad (5.6)$$

where

- P = design pressure (or line load for plating)
- A = a constant depending on class and whether the load is for plating or framing
- L = ship length
- α = angle between the waterline and the ship centerline at:
0.1 L aft of the fwd perpendicular for plating design and
0.2 L aft for framing design
- μ = a function of β depending on ice class and application to plating or framing

Although the above is a simplification, it is based on a theoretical estimation of hull-ice impact loads.

For the remainder of the ship's hull, the Russian rules specify design pressures in the form

$$P = L - \text{constant (plating)} \quad (5.7)$$

$$P = \text{constant} \cdot L \quad (\text{framing}) \quad (5.8)$$

The rationale for these relationships are that in the midbody, design loads should be taken as the compressive strength of ice multiplied by a function of ice thickness and that this thickness should vary with ship class and size. Since impact loads at the stern will be small due to low velocities, these same pressures are used.

Structural design techniques for plating are similar to those discussed previously in that plating is designed to just prevent development of plastic hinges. When plating thickness is less than 21.8 mm, a corrosion allowance of 4 mm is provided. The factor of safety used (if any) is not known since relationships include constants for load distributing effects. In the case of transverse framing, ice loads are expressed as line loads (force per unit length) and are applied at mid-span.

5.3.5 Lloyd's Register of Shipping

Although Lloyd's Register of Shipping incorporates the Finnish-Swedish Rules for Navigation in Ice, a parallel classification system for ice strengthening is also specified. Classes 1*, 1, 2, and 3 specify scantlings for ice strengthening as percentage increases over a basic plating thickness and frame spacing. Unlike the rules discussed previously, however, these increases are applied to basic scantlings calculated for ice rather than the normal rule scantlings. Basic scantlings are calculated as follows:

$$s_b = \left(\frac{L}{50} + 20 \right) \quad (5.9)$$

$$t_b = \left(0.20 + \frac{L}{1140} \right) \sqrt{\frac{S}{s_b}} \quad (5.10)$$

where S_b = basic frame spacing [in]
 L = length of the ship [ft]
 S = frame spacing [in]
 t_b = basic plating thickness [in]

It is evident from the above that basic scantlings are calculated as a minimum plus an increase for ship size. These values are then modified by percentage increases for each of the four ice classes.

Lloyd's Register of Shipping, in addition to classing ice-strengthened vessels, issues a classification for icebreakers. The structural requirements for the class 100AI Icebreaker are unpublished and each vessel is considered individually. Insight regarding the ice load criteria is provided by Crighton [D-3] who suggests that design pressure be calculated as a function of displacement \times horsepower. However, the expression used is a function of SHP $\times L \times B \times 10^{-6}$. The one example given is for transverse frames

$$S.M. = k \times 0.54 \times l^2 \quad (5.11)$$

where l = span of the frame
 k = a function of SHP $\times L \times B \times 10^{-6}$

Included in the above expression are the assumptions that the frame is uniformly loaded between supports and the yield stress of the material is 16 ton/in².

5.3.6 Det norske Veritas

Det norske Veritas specifies ice strengthening criteria for three classes in addition to those which are identical to the Finnish-Swedish Regulations. These three classes are ICE C, ICEBREAKER, and ARCTIC ICEBREAKER. The level of strengthening for the Class ICE C is generally not to exceed that for ICE IC (IC from the Finnish-Swedish Regulations). For the Class ICE C, transverse frame section modulus is specified as a function of frame spacing, ship length, and draft as:

$$Z = 0.4 L S d \text{ (main frames)} \quad (5.12)$$

$$Z = \frac{L^2}{100} + 20 \text{ (intermediate frames)} \quad (5.13)$$

where Z = section modulus
 L = ship length
 S = frame spacing
 d = draft

Plating thickness (t) at the bow is specified as a function of ship length (L),

$$t = 6 + 0.11 L \quad (5.14)$$

For the class ICEBREAKER, scantlings are calculated as a function of the ratio of installed power to ship beam. Ordinary frames below the design waterline

and those forward of the collision bulkhead are designed to

$$Z = 7 D d S \quad (5.15)$$

or $Z = k l^2 S \quad (5.16)$

where $Z =$ section modulus (5.17)

$$k = f \frac{P_s}{B}$$

$P_s =$ shaft horsepower

$B =$ beam

$D =$ depth

$d =$ draft

$l =$ span of the frame

$S =$ frame spacing

In a similar manner, plating thickness (t) is calculated as:

$$t = 25 S \left(1 + \frac{P_s}{735B} \right) \quad (5.18)$$

The factor P_s/B is essentially a load per unit width based on propulsion forces only.

Scantlings for the class Arctic ICEBREAKER are specified by percentage increases above those specified for ICEBREAKER.

5.3.7 Nippon Kaiji Kyokoi

Nippon Kaiji Kyokoi specifies ice strengthening for four classes in addition to those which are identical to the Finnish-Swedish Regulations. Plating thicknesses for these four classes are specified as:

$$t = C\sqrt{SVL'} + 3.5 \quad (5.19)$$

where $t =$ thickness of plating
 $C =$ contact depending on class and hull area
 $S =$ frame spacing
 $V =$ ship speed
 $L' =$ ship length

The factor VL' , in a sense, is a measure of the potential impact load when the ship collides with an ice floe. This is in contrast to Det norske Veritas where propeller forces per unit width are used as a measure of hull loading. The section modulus of transverse frames is specified as a function of frame spacing, span, and ship length.

5.3.8 USCG Icebreaker Design Practice

In recent years, the U.S. Coast Guard has completed preliminary designs of several icebreakers including the POLAR Class, a Great Lakes and Eastern Arctic Icebreaker (WBAL), and a Great Lakes Icebreaking Tug (WYTM). In addition, operating experience has been developed with the WIND Class, the GLACIER, the MACKINAW,

and the POLAR Class. The method of approach used in the recently completed designs has been to specify a design ice pressure and derive scantlings based on state-of-the-art structural analysis techniques, such as two-or three-dimensional finite-element analysis.

During the design of the POLAR Class (1966-1971), available data on crushing strength of ice were compiled as described by Barber et al [B-2]. The maximum crushing strength of ice was determined to be 1,000 psi. Average design pressures for the midbody and bow and stern areas were derived by multiplying this maximum crushing strength by factors to account for sample size, strength profile, contact area, and data reliability. Design values of 300 psi and 600 psi were derived for uniform static loads and impact loads respectively. These were applied to the POLAR Class hull as shown in Figure 5.6. The structural design philosophy used was to design the shell structure to within elastic limits for the above pressures. With plastic deformation, the bow and stern shell structures are then capable of withstanding 1,200 psi. For the supporting structure, the 600 psi impact loads are assumed to be distributed over a larger area supported by many transverse frames.

The preliminary design of the WBAL [D-23] specified uniform ice pressures of 300 psi forward, 240 psi aft, and 200 psi in the midbody. This decrease is based on the different sizes and dimensions of the two ships and further analysis of damages to existing Coast Guard icebreakers [G-1] and consideration of the mission of the ship. For example, the original WIND Class structures could withstand approximately 150 psi and there were numerous failures. However, no failures have been experienced since the structures were upgraded to approximately 300 psi. The required design ice pressures are thought to take the form shown in Figure 5.7, where a maximum uniform pressure of 300 psi is reduced as ship size decreases. For example, the new 140 ft Great Lakes icebreakers are designed to approximately 80 psi as compared to 300 psi for the 315 ft WBAL.

5.3.9 Empirical and Theoretical Prediction of Ice Loads

Two approaches to ice strengthening which have not been discussed above are empirical and/or theoretical predictions of the ice loads acting on a particular hull due to a particular ice feature. Although no classification society or government regulatory body employs this procedure, several examples of load prediction methods are available in the literature.

Levine et al [B-23] suggest that ice loads can be determined with an empirical expression based on full-scale test data. The following expression is given:

$$\frac{F_i}{\rho_w g h^3} = 0.385 \left(\frac{1}{\alpha_3} \right)^{1.31} \left(\frac{\alpha_1 V}{\sqrt{gh}} \cdot \frac{\sigma_f}{\rho_w g h} \right)^{1.17} \quad (5.20)$$

where

- F_i = ice force on the hull
- ρ_w = density of water
- g = acceleration of gravity
- h = ice thickness

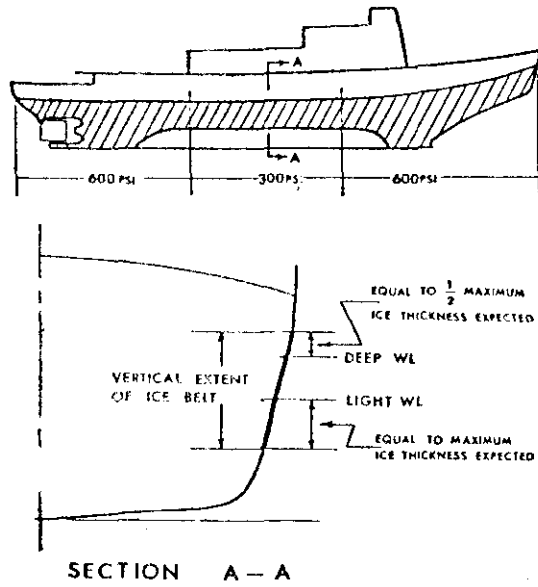

Figure 5.6 Polar Class Icebelt Configuration Showing Design Pressures [B-28]

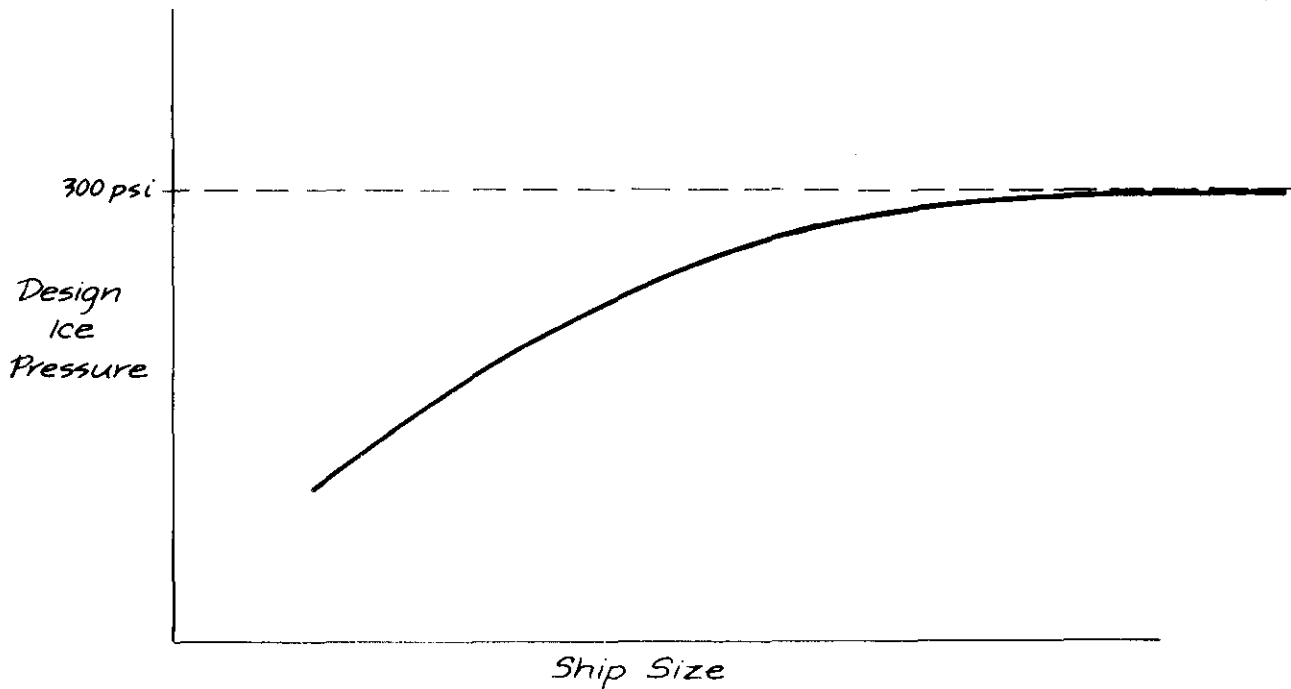

Figure 5.7 Design Ice Loads for Icebreakers Based on USCG Experience

α_3, α_1 = direction cosines of the hull at the point of impact

V = ship speed

σ_f = flexural strength of ice

The above expression is based on test data collected in the Great Lakes for the USCGC MACKINAW and the bulk carrier LEON FRASER as shown in Figure 5.8. This suggests that ice forces on the hull are functions of ice thickness and strength, ship speed, and the shape of the hull at the point of impact. Although the above expression gives the total force due to ice, the distribution of this force is not addressed and, therefore, it is somewhat limited as a design tool.

Major, et al [B-26] published a theoretical computer model used to calculate ice loads on ships operating in the Gulf of St. Lawrence. This model is based on the work of Popov, et al [B-38]. Both models will, therefore, be discussed concurrently. The basis for this work is a rigorous solution of the equations of motion for the ship and the ice floe. The basic model of Popov was modified by Major to include inertial effects related to broken ice, added mass due to water beneath the ice, and an exact solution for failure of the ice sheet. The modified model is capable of predicting loads for several cases: (1) ship impact with a discrete floe; (2) continuous breaking of an infinite floe; (3) reflected impacts; and (4) ice compression due to pressure in the ice. Ship characteristics, hull form, ice properties, and operating conditions such as speed are input to the model. Output consists of predicted ice loads as a function of position on the hull, the distribution of these loads, and the impact time. A sample application of this model was included in Section 2.2.2 of this report. As discussed by Major, the model appears to be conservative in that predicted loads are greater than those measured during full-scale tests.

5.4 Resulting Scantlings for Three Representative Ships

In order to determine the effects of alternate ice strengthening criteria on actual ship structures, scantlings have been calculated for three representative ships using each of the criteria identified in Section 5.1. The three ships selected for this analysis are: (1) the USCGC POLAR STAR, a modern ice-breaker described in Ref. [B-2]; (2) the MV ARCTIC, a recently constructed bulk carrier designed for operations in the Canadian Arctic [G-10]; and (3) a proposed Arctic Tanker designed for shipment of Alaskan oil through the Canadian Arctic [B-32].

These three ships represent a wide variation in size as shown in Table 5.7; the structural configurations are shown in Figure 5.9. POLAR STAR is transversely framed with frames supported by closely spaced decks. MV ARCTIC is a transversely framed bulk carrier with side tanks. Although the MV ARCTIC has stringers spaced at approximately 4 ft intervals, a frame span of 27 ft was assumed for this analysis to illustrate the effects of relatively large unsupported frame lengths. The Arctic Tanker is framed longitudinally with transverse ice frames supported by closely spaced stringers. Calculated American Bureau of Shipping rule scantlings for each ship are given in Table 5.8 also. These have been used as a basis for calculating ice strengthened scantlings in those cases where percentage increases are specified. For each of the three ships, plating thickness and transverse frame section modulus have been calculated using all of the previously

TABLE 5.7 PRINCIPAL CHARACTERISTICS OF THREE REPRESENTATIVE SHIPS

	POLAR STAR	MV ARCTIC	ARCTIC TANKER
Length Overall (ft)	399	687	1,247
Length, DML (ft)	352	645	
LBP (ft)			1,150
Beam, Max. (ft)	83.6	75.0	198.0
Beam, DML (ft)	78.0	75.0	189.0
Depth (ft)	49.3	50.0	105.0
Design Draft (ft)	28.0	36.0	80.0
Displacement at DML (L.T.)	11,000	36,636	370,800
SHP	60,000	14,770	210,000

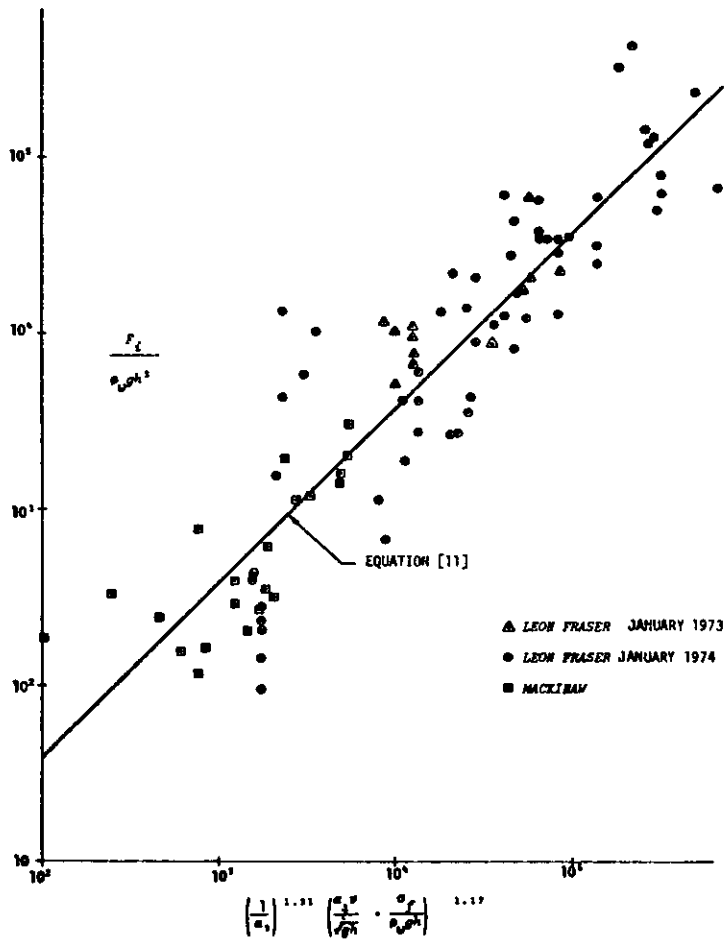

Figure 5.8 Regression of Full-Scale Ice Load Data from the Mackinaw and Leon Fraser Tests

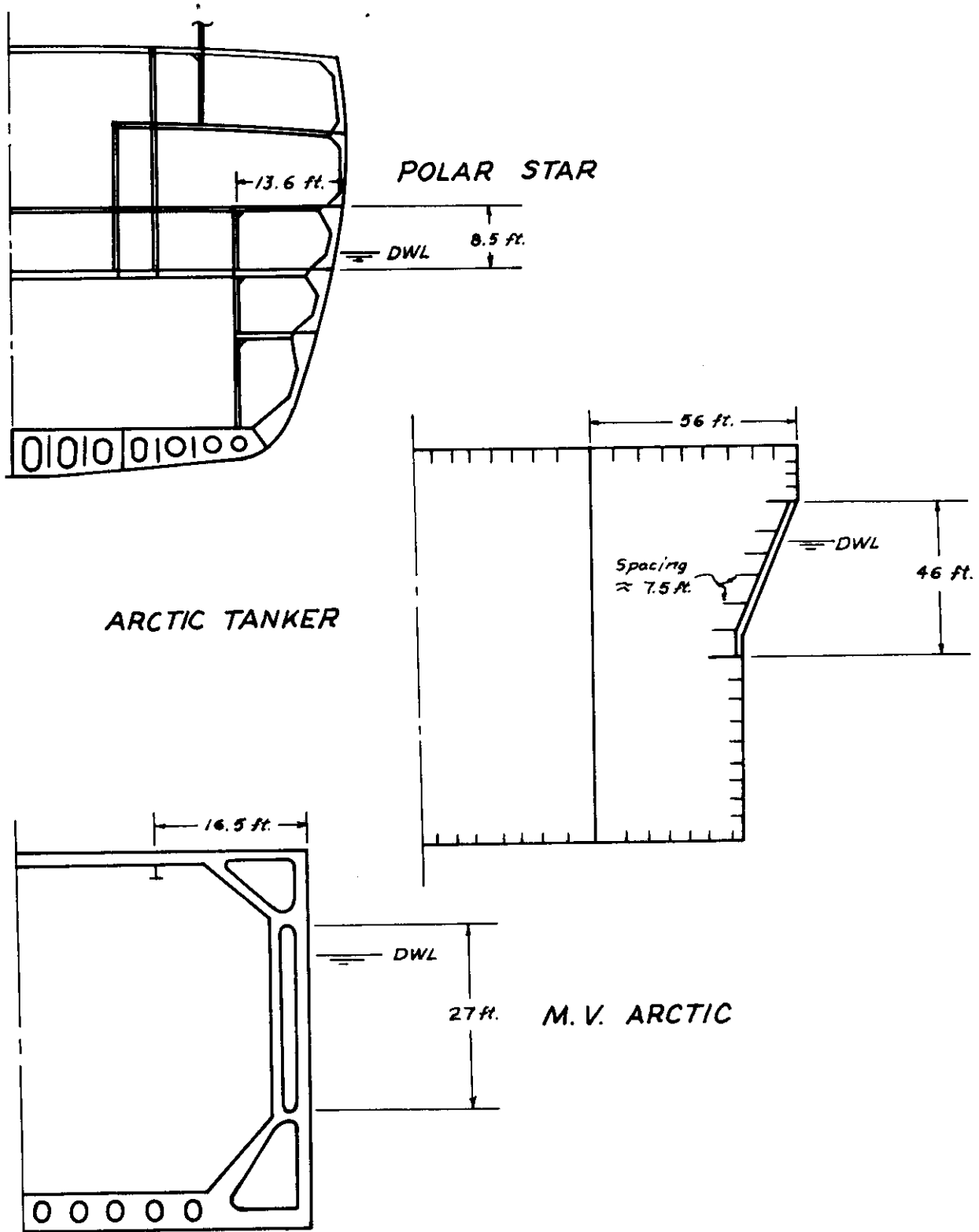

Figure 5.9 Assumed Structural Configuration of Three Representative Ships

TABLE 5.8 AMERICAN BUREAU OF SHIPPING SCANTLINGS
FOR THREE REPRESENTATIVE SHIPS

	<u>POLAR STAR</u>	<u>MV ARCTIC</u>	<u>ARCTIC TANKER</u>
Rule Length, L (ft)	341 (0.97xLWL)	626 (0.97xLWL)	1,150
Midship Frame Spacing (in)	25.8	32.9	39.5
Midship Shell Plating Thickness (in)	0.40	0.67	1.05
End Shell Plating Thickness (in)	0.42	0.60	0.78
Immersed Bow Plating Thickness (in)	0.48	0.71	0.95
Bottom Shell Plating Amidships (in)	0.47	0.80	1.21
Bottom Plating Forward (in)	0.60	0.94	1.46
SM of Midship Transverse Frame (in ³)	5.8	116.9	38.4

discussed classification society rules and government regulations. The results of these calculations for the bow, midbody, and stern portions of each ship are shown in Appendix B-1 of Volume II. The following paragraphs discuss and compare: (1) the loads used to calculate scantlings; (2) the resulting plating thicknesses; and (3) the resulting frame section modulus for each of the rules and regulations.

Several of the ice strengthening criteria considered specify ice loads in terms of a pressure which is used to calculate scantlings. These criteria include the Canadian ASPPR, the Finnish-Swedish Regulations for Navigation in Ice (and all identical classification society rules), the Russian Rules for the Classification and Construction of Sea-Going Ships, and the criteria proposed by Johansson [B-16]. Since each of these criteria, except the Canadian ASPPR, calculate design pressures based on certain hull characteristics, comparison of the resulting pressures for representative ships is useful.

Plating and transverse framing design pressures (from Appendix B-1) for the bow areas of the three ships considered are shown in Figure 5.10 and Figure 5.11. In each case, the Finnish-Swedish Regulations (and identical classification society rules) specify the lowest plating design pressures. The criteria proposed by Johansson and the Russian Rules specify slightly higher pressures; the ASPPR specify the highest pressures. Several differences between these four criteria should be noted. The ASPPR specify similar pressures for any ship of a particular class with the exception that vessels without double hulls must use higher pressures (as in the case of the Arctic Tanker). Johansson's criteria and the Finnish-Swedish Regulations specify pressures as functions of displacement times horsepower; however, each of the ships considered must use the maximum required pressures and, therefore, design pressures for the three ships are approximately equal. The Russian Rules specify design pressures as functions of ship length and hull shape, and design pressure increases rapidly as length increases.

With the exception of the ASPPR, each of the criteria shown in Figures 5.10 and 5.11 specify framing design pressures which are less than the corresponding plating design pressures. The difference between these pressures is relatively small for the Finnish-Swedish Regulations and Johansson's criteria. The Russian Rules specify framing design loads as force per unit length and can, therefore, not be readily compared to the pressures. One further difference between the above criteria is the variation in design pressure with hull area. As illustrated in Figure 5.12, all of the criteria specify reduced pressures for the midbody as compared to the bow; however, pressures required in the stern area vary greatly. The ASPPR specifies stern design pressures greater than midbody pressures; the Finnish-Swedish Regulations and Johansson specify stern pressures which are less than midbody pressures; and the Russian Rules specify stern pressures identical to midbody pressures.

Calculated ice strengthened scantlings for the three ships are included in Appendix B-1. Web frames, stringers, decks and bulkheads have not been considered; scantlings have only been calculated for the shell plating and the associated stiffeners (transverse ordinary and intermediate frames) for the bow, midbody, and stern areas of the ice belt. No attempt has been made to optimize the structures with respect to weight or cost. For those rules which specify percentage increases in rule scantlings, the American Bureau of Shipping ~~TA~~ scantlings were

* All classification is the basic ABS open water class for unrestricted ocean service at the assigned freeboards.

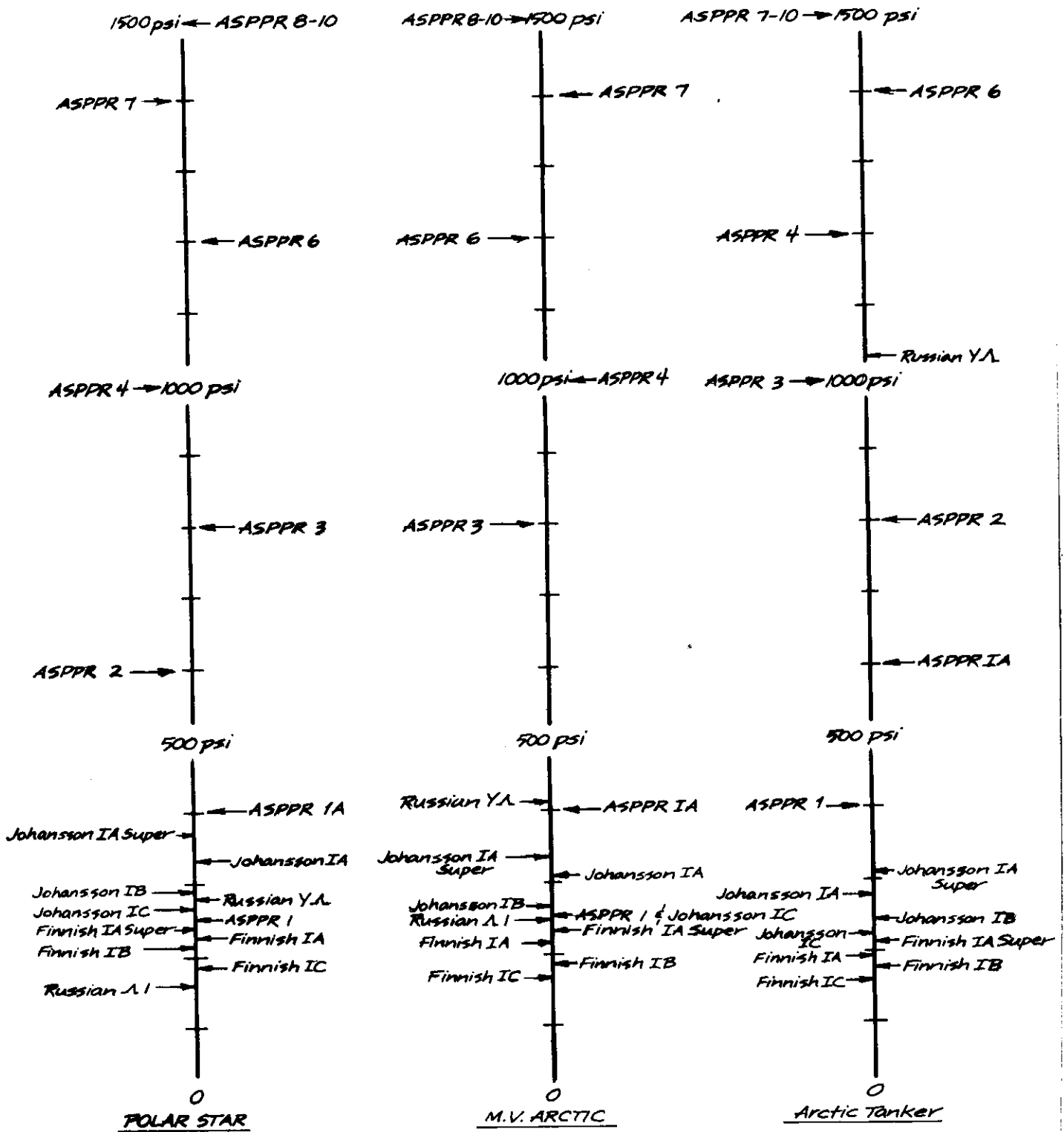

Figure 5.10 Comparison of Bow Plating Design Pressures for Three Representative Ships

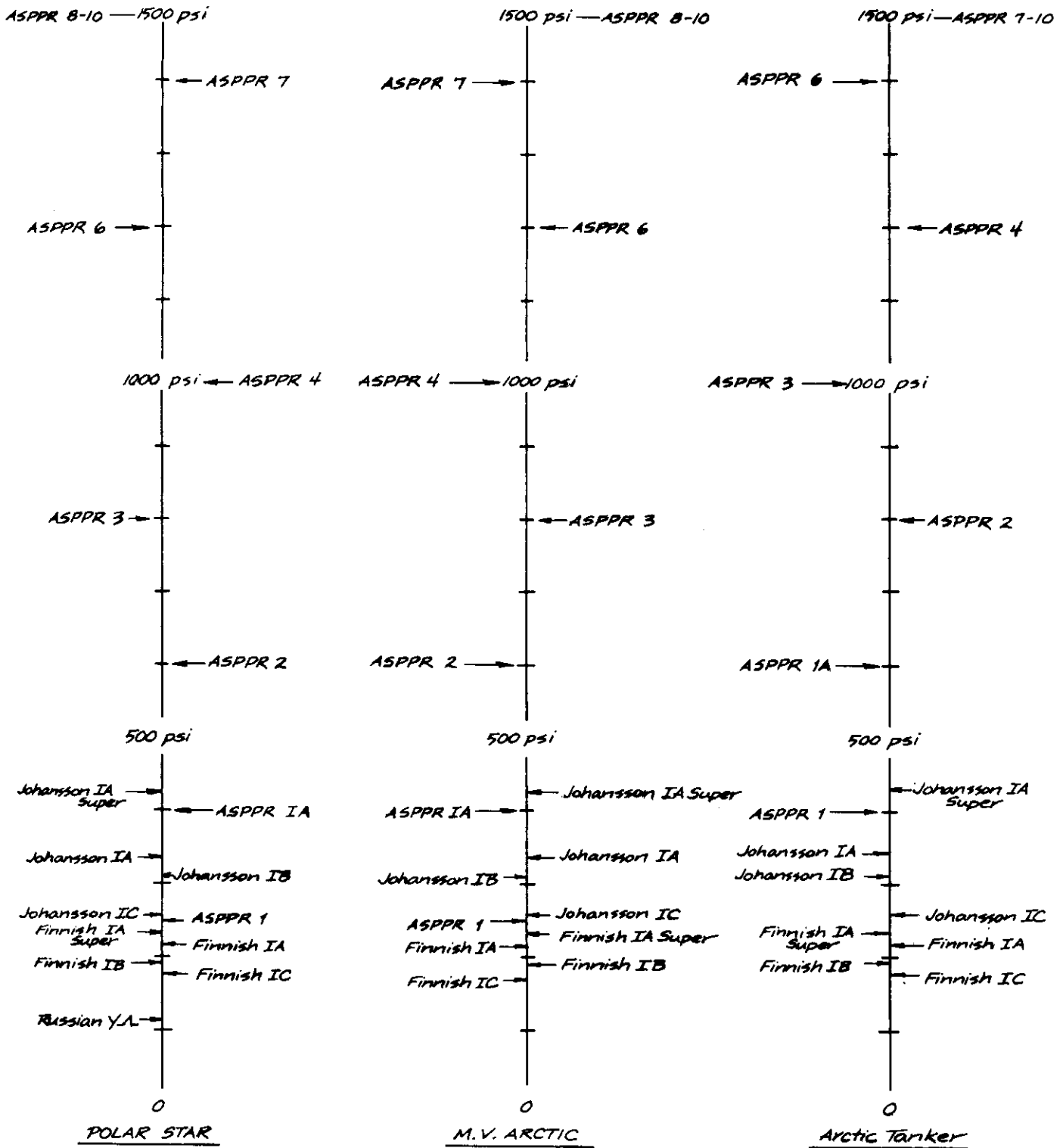

Figure 5.11 Comparison of Bow Transverse Frame Design Pressures for Three Representative Ships

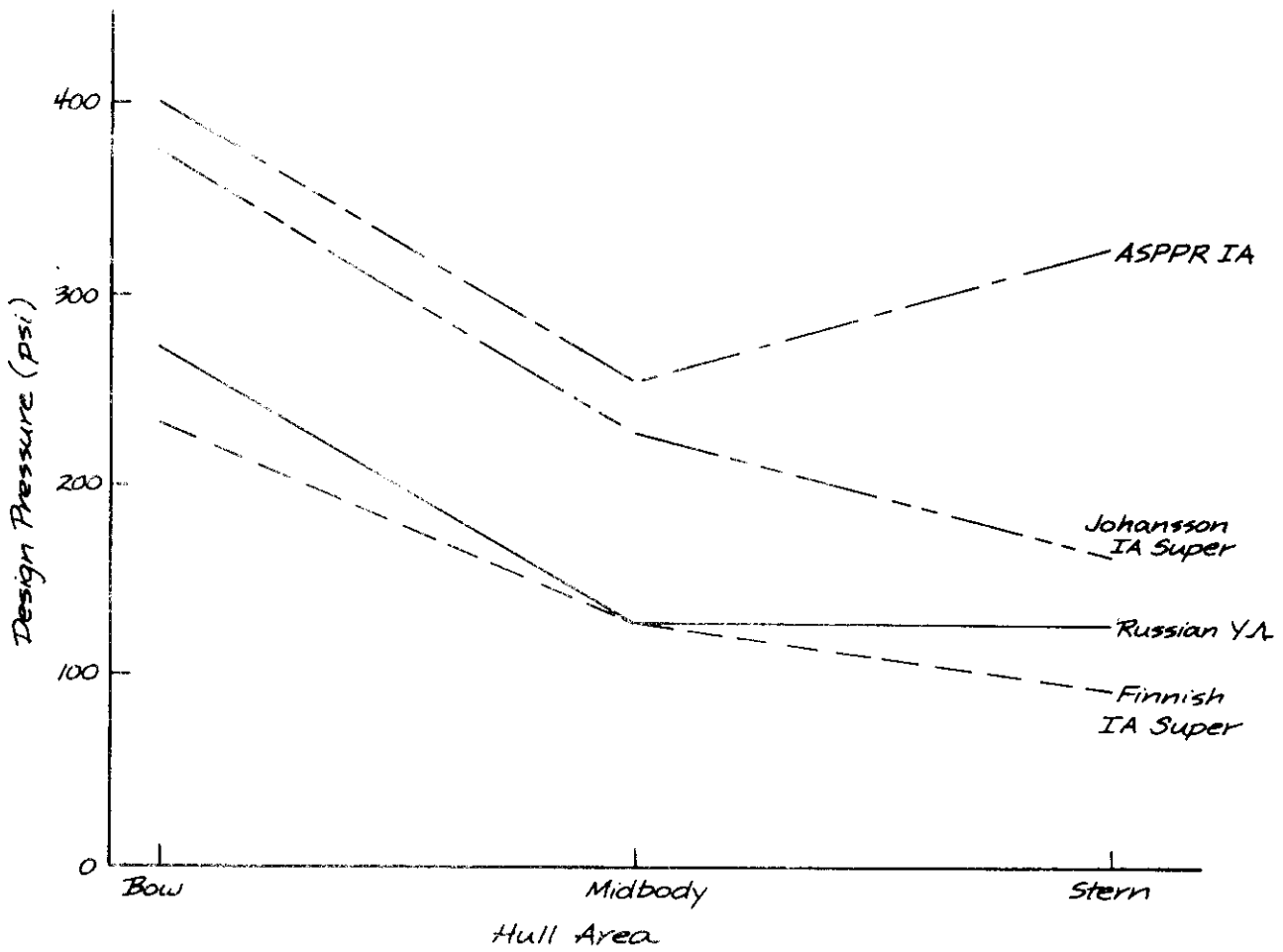

Figure 5.12 Variation in Plating Design Pressure with Hull Area for POLAR STAR

used as the basic rule scantlings. With respect to the Canadian ASPPR, only the three hull areas at the waterline were considered and the ships were assumed to have three different configurations with respect to double hulls: (1) the MV ARCTIC was assumed to have side tanks; (2) POLAR STAR was assumed to have no side tanks, however, no waste is stored next to the hull; and (3) the Arctic Tanker was assumed to have no side tanks and waste is stored next to the hull.

Table 5.9 summarizes the calculated bow shell plating thicknesses for the three ships. The highest and lowest classes from each of the rules and regulations considered are illustrated in the table. In cases where required plating thickness varies throughout the bow area, the average thickness is shown. Also, where frame spacing is not specified, the ABS #A1 midbody spacing is used. Comparison of plating thickness as a function of ice strengthening criteria, or ship parameters, is difficult due to the required variations in frame spacing. Therefore, the next section of the report will compare the load-carrying capability of these plating thicknesses and frame-spacing combinations.

Table 5.10 provides a summary of the required bow transverse frame section modulus for the highest and lowest ice classes from each rule or regulation. Frame spacing varies as described above for plating thickness; the frame spans used in the analysis are 8.5 ft for POLAR STAR, 27 ft for the MV ARCTIC, and 7.5 ft for the Arctic Tanker. The load-carrying capability of the resulting framing will be discussed and compared in the following section.

5.5 Analysis of the Load-Carrying Capability of Resulting Scantlings

A meaningful comparison of ice-strengthened scantlings based on the various criteria is difficult due to specified variations in frame spacing which in turn affect plating thickness and frame section modulus. Therefore, a comparison of the load-carrying capabilities of the resulting structures has been made. The uniform pressures (distributed over an 800 mm band) which the structures of the three ships will withstand have been calculated using the plastic-elastic method which was used by Johansson [B-16] in the analysis of ice damage data. Results of the calculations and a description of the analysis method are contained in Appendix B-2 of Volume II.

The load-carrying capabilities of ice strengthened bow structures for each of the three ships are compared in Figures 5.13 through 5.15. With the exception of the Canadian ASPPR, only the highest ice class from each rule or regulation is included. Review of these figures leads to several observations. First, the load-carrying capacity of structures designed to the classification society rules, all of which are intended for "extreme" ice conditions, varies greatly. For example, the bow plating on POLAR STAR would be designed to withstand between 440 psi and 1,950 psi depending on which classification society ice class is used. Secondly, all of the Canadian ASPPR classes above Class IA yield structures which are significantly stronger than the other rules and regulations. Several exceptions to this should be noted, however. The Det norske Veritas Icebreaker and Arctic Icebreaker classes require very heavy plating for the Arctic Tanker. This is due to the fact that plating thickness is calculated as a function of horsepower divided by beam and the rules were probably not intended for ships similar to the tanker with 210,000 SHP. These two classes and the Nippon Kaija Kyokai classes require very heavy framing for the MV ARCTIC. In both cases, section modulus is calculated as a function of frame span squared. Thus, a very large span (27 ft) was used for the MV ARCTIC.

TABLE 5.9 ICE STRENGTHENED BOW PLATING THICKNESS
FOR THREE REPRESENTATIVE SHIPS

RULE OR REGULATION	CLASS	Plating Thickness [in]		
		POLAR STAR (s=26 in.)	MV ARCTIC (s=33 in.)	ARCTIC TANKER (s=40 in.)
ABS	†A1	0.42	0.60	0.78
	A	0.60 ²	1.00 ³	1.00 ⁴
	C	0.50 ²	0.84 ³	1.00 ⁴
FINNISH-SWEDISH ¹	IA-Super	1.26	1.57	1.81
	IC	1.11	1.35	1.55
LLOYD'S	1*	1.25 ²	1.25 ³	1.25 ⁴
	3	0.50 ²	0.67 ³	1.00 ⁴
CANADIAN ASPPR	1	1.22	1.55	2.36
	10	2.98	3.80	4.56
DET NORSKE VERITAS	ICE C	0.69 ⁵	1.00 ⁵	1.00 ⁵
	ICEBREAKER	1.38 ²	0.85 ⁴	3.17 ⁶
	ARCTIC ICEBREAKER	1.79 ²	1.11 ⁴	4.12 ⁶
BUREAU VERITAS	Glace I-Super	1.26 ²	1.26 ³	1.26 ⁴
	Glace III	0.50 ²	0.84 ³	1.00 ⁴
USSR RULES	YA	0.71 ²	1.06 ³	2.02 ⁴
	A4	0.50 ³	0.84 ⁴	1.00 ⁷
NIPPON KAIJI KYOKAI	AA	1.20 ³	1.44 ³	1.83 ⁴
	C	0.87 ³	1.03 ³	1.30 ⁴
PEOPLES REPUBLIC OF CHINA	BI*	0.72 ²	1.21 ³	1.26 ⁴
	BIII	0.50 ²	0.84 ³	1.00 ⁴

¹And all identical classification society rules

²Frame spacing = 13 ins.

³Frame spacing = 16.5 ins.

⁴Frame spacing = 20 ins.

⁵Frame spacing = 12 ins.

⁶Frame spacing = 27 ins.

⁷Frame spacing = 24 ins.

TABLE 5.10 ICE STRENGTHENED BOW TRANSVERSE
FRAME SECTION MODULI FOR THREE
REPRESENTATIVE SHIPS

RULE OR REGULATION	CLASS	Transverse Frame S.M. [in ³]		
		POLAR STAR (s=26 in.)	MV ARCTIC (s=33 in.)	ARCTIC TANKER (s=40 in.)
ABS	+A1	5.8	116.9	38.4
	A	5.8 ²	116.9 ³	38.4 ⁴
	C	5.1 ²	102.3 ³	33.6 ⁴
FINNISH SWEDISH ¹	IA-Super	51.4	234.2	67.8
	IC	37.5	170.8	49.4
LLOYD'S	1*	5.8 ²	116.9 ³	38.4 ⁴
	3	4.8 ²	96.5 ³	31.7 ⁴
CANADIAN ASPPR	1	54.8	249.7	106.2
	10	328.8	1498.1	398.4
DET NORSKE VERITAS	ICE C	7.4 ⁵	170.8 ⁵	49.4 ⁵
	ICEBREAKER	27.5 ³	1167.0	61.2 ⁶
	ARCTIC ICEBREAKER	34.4 ³	1451.0	76.5 ⁶
BUREAU VERITAS	Glace I-Super	8.7 ²	175.4 ³	57.6 ⁴
	Glace III	5.1 ²	102.3 ³	33.6 ⁴
USSR RULES	YA	15.6 ²	120.6 ³	70.5 ⁴
	A4	5.8 ³	116.9 ⁴	38.4 ⁷
NIPPON KAIJI KYOKAI	AA	57.1 ³	10.9 ³	185.7 ⁴
	C	12.1 ³	2.3 ³	39.4 ⁴
PEOPLE'S REPUBLIC OF CHINA	BI*	11.6 ²	23.4 ³	76.8 ⁴
	BIII	5.8 ²	116.9 ³	38.4 ⁴

¹And all identical classification society rules

²Frame spacing = 13 ins.

³Frame spacing = 16.5 ins.

⁴Frame spacing = 20 ins.

⁵Frame spacing = 12 ins.

⁶Frame spacing = 27 ins.

⁷Frame spacing = 24 ins.

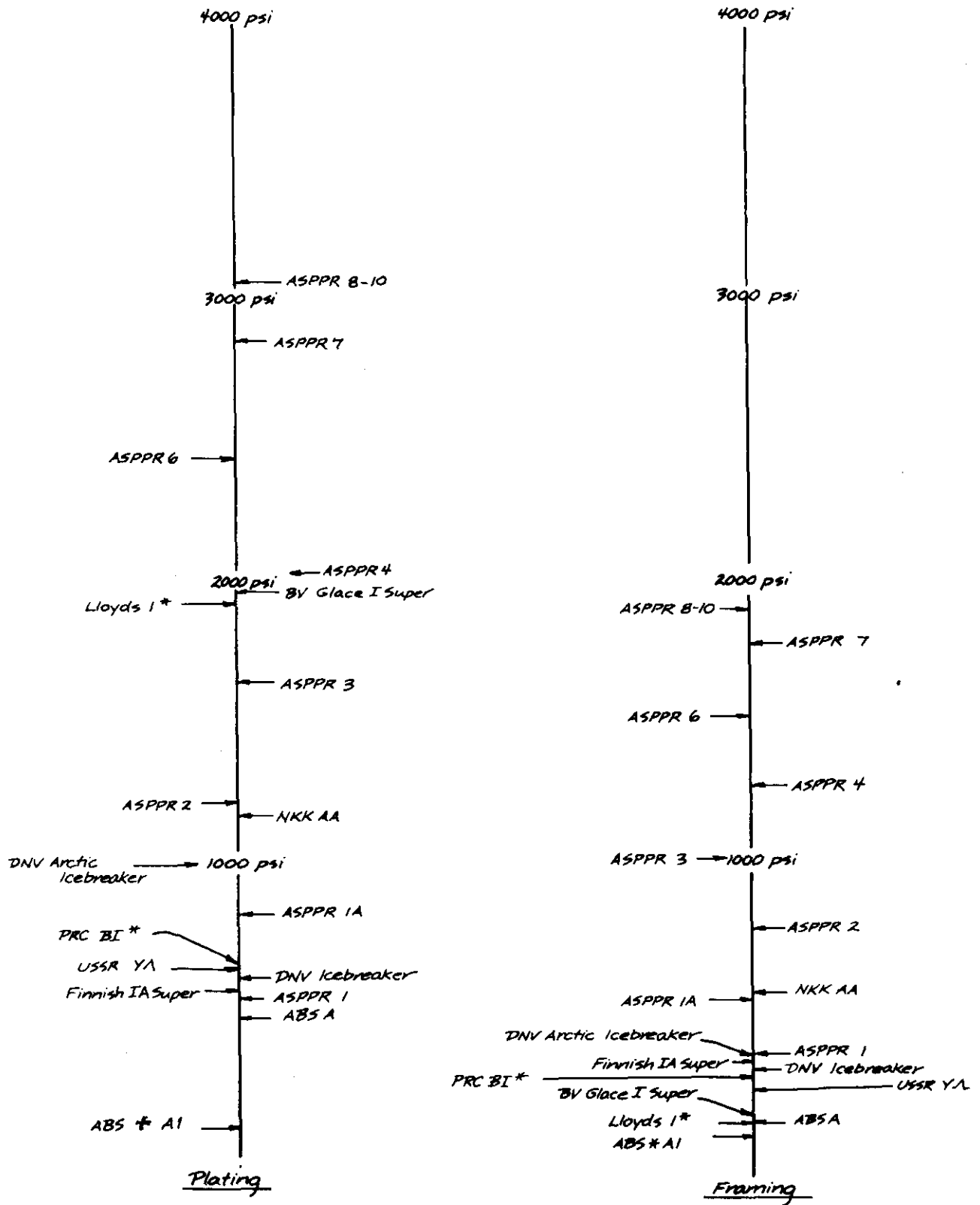

Figure 5.13 Load-Carrying Capability of POLAR STAR Bow Structure for Various Ice Strengthening Criteria

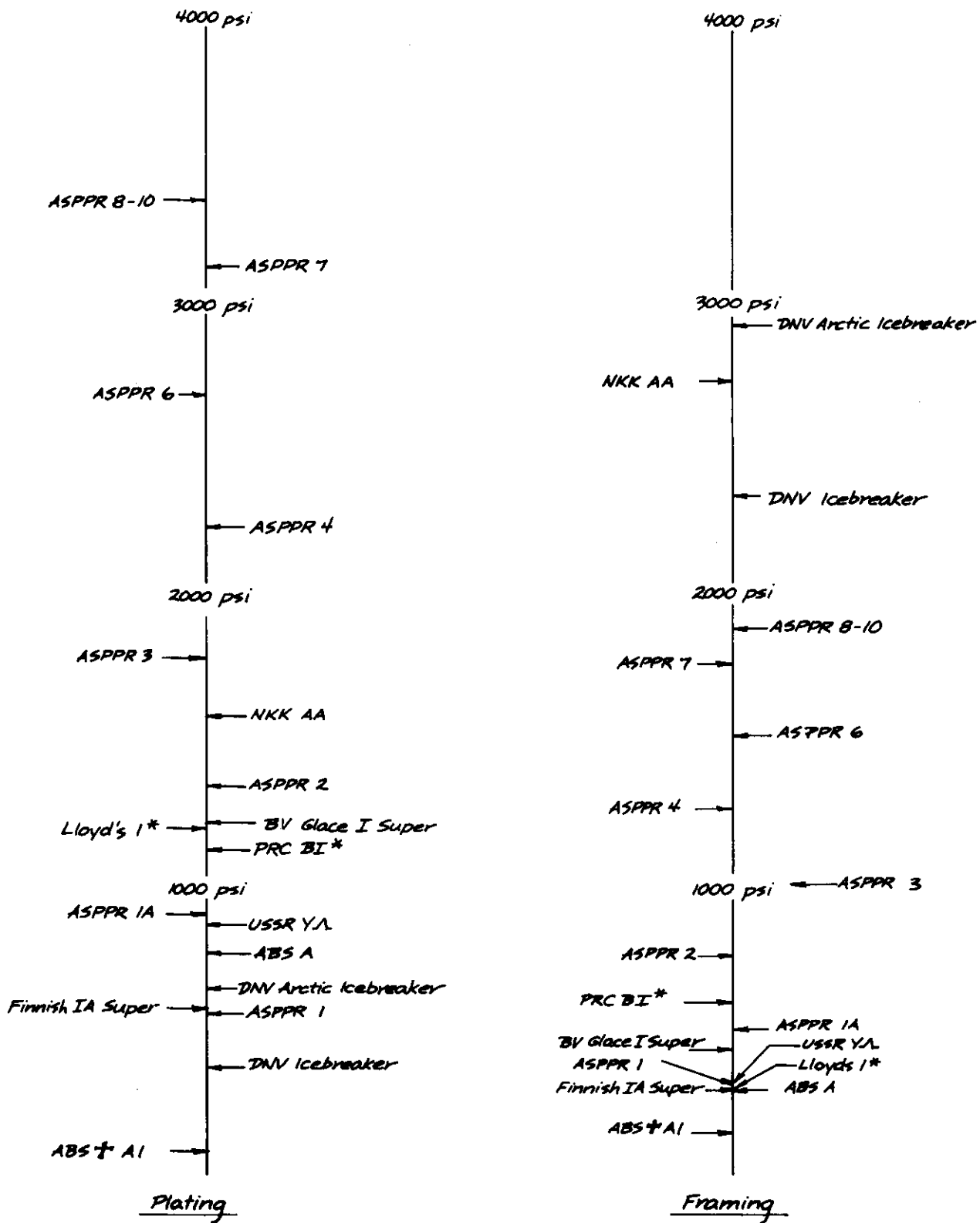

Figure 5.14 Load-Carrying Capability of MV ARCTIC Bow Structure for Various Ice Strengthening Criteria

5,131 psi DNV Arctic Icebreaker

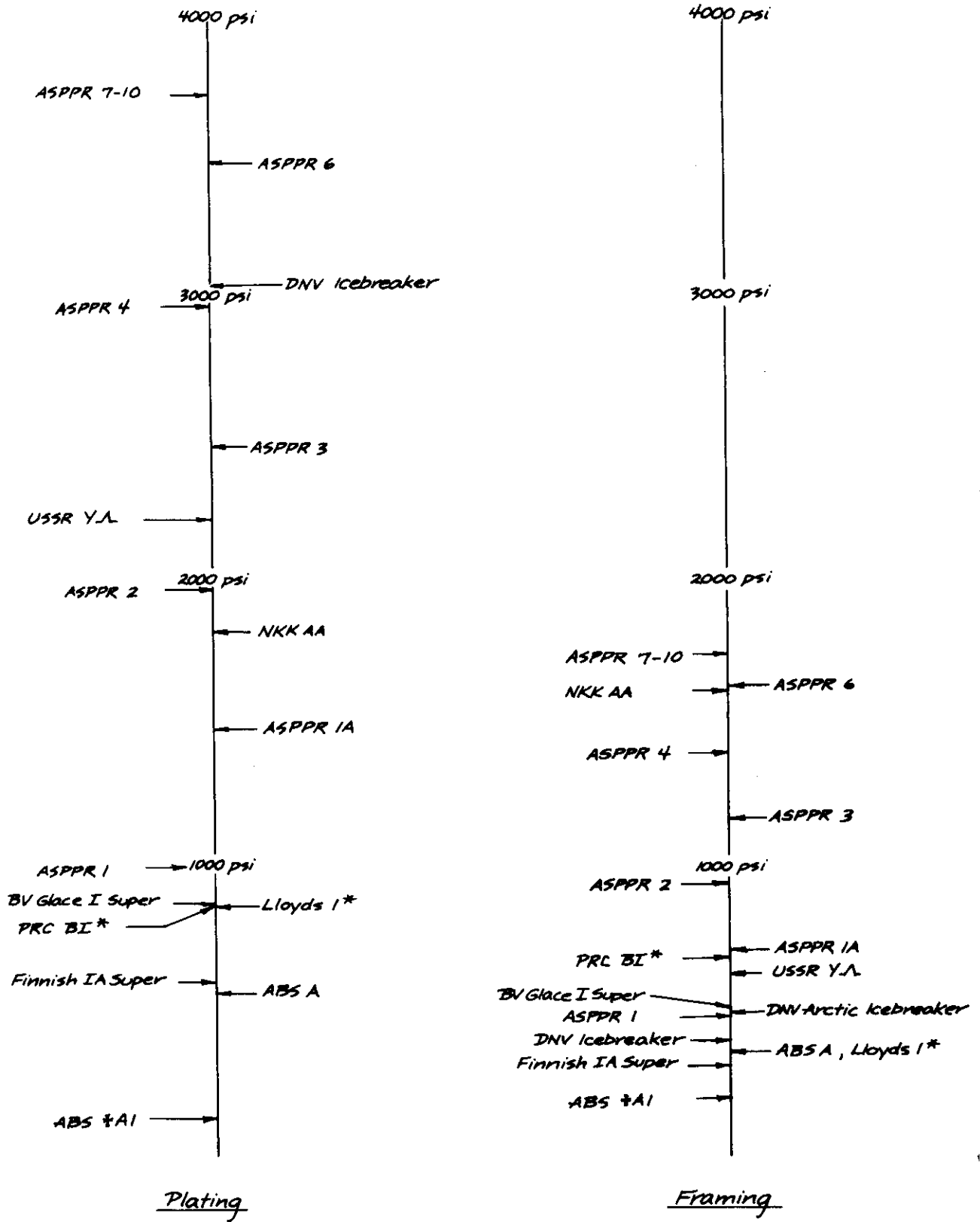

Figure 5.15 Load Carrying Capability of Arctic Tanker Bow Structure for Various Ice Strengthening Criteria

In most cases, the load-carrying capacity of transverse frames is less than the load-carrying capacity of shell plating for the same ice class. In addition, the classification society rules are more consistent with respect to frame strength than they are for plating. Most of the classification society rules yield framing which will withstand 50-700 psi. As is the case for plating, the Canadian ASPPR classes above Class IA typically require stronger framing than any of the classification society rules.

5.6 Analysis of Equivalence Between Certain Criteria

The various ice strengthening criteria which have been examined may be divided into the following broad categories:

- (a) Criteria which use an incremental approach to increase the thickness and stiffening over the rule values based on non-strengthened ship design. Examples of this category are Lloyd's Register of Shipping, Bureau Veritas, and the Register of Shipping of the Peoples' Republic of China.
- (b) Criteria which use estimates of ice pressures based on ship characteristics, i.e. horsepower, displacement, length or hull angles at specified stations. Examples are the Soviet and Polish regulations, as well as Finnish-Swedish Ice Rules and all identical classification society rules.
- (c) Criteria which define the operating environment of ships to determine the appropriate ice class and, hence, use corresponding values of ice pressure and load to compute the structural requirements. The only set of criteria which may be listed in this category is the Canadian Arctic Shipping Pollution Prevention Regulations (ASPPR).

While categories (a) and (b) use an arbitrary system for class selection which places the responsibility of classing a ship entirely on the owner, category (c) is more restrictive in this regard and once the owner specifies the zone of operation and time of the year, the class can easily be determined from selection schedules of the regulations.

In order to be able to compare the various criteria, a common ground must be established as a basis of comparison. In view of the failure of the classification society rules to specifically relate ice conditions to ice classes, it is necessary to establish some equivalence between the classification society classes. In this comparison, ships of equivalent classes can operate under similar environmental (ice) conditions with the same desired level of safety. There are no direct procedures which establish equivalence between ice classification on this basis. In the following paragraphs, an attempt will be made to establish a basis for equivalence among various ice strengthening criteria for commercial ships. The comparison will be based on the required design pressure versus the level ice thickness in which the ship is designed to operate continuously.

Consider a typical ice class cargo ship with:

- Thrust to power ratio, $T/P = \alpha_1$
- Power to displacement ratio, $P/\Delta = \alpha_2$
- Basic dimensions, length L , beam B and draft D

- Block coefficient, C_b
- Dimensionless ratios: L/B , B/D
- Hull lines and angles, α and β

Other Symbols are defined in Table 5-11.

The displacement of the ship may be expressed in terms of ship length as follows:

$$\begin{aligned}\Delta &= \rho_w g L B D \cdot C_b \\ &= \rho_w g C_b L^3 / [(L/B)^2 \cdot (B/D)] \\ \Delta &= \alpha^3 L^3\end{aligned}\tag{5.21}$$

where α_3 is a constant which depends on ship geometry as

$$\alpha_3 = \rho_w g C_b / [(L/B)^2 \cdot (B/D)].$$

The ship power may be expressed in terms of length as follows:

$$\begin{aligned}P &= (P/\Delta) \cdot \Delta \\ &= a_2 \cdot a_3 L^3 \\ P &= a_4 L^3\end{aligned}\tag{5.22}$$

where

$$a_4 = a_2 \cdot a_3$$

Similarly ship thrust may be written:

$$\begin{aligned}T &= (T/P) \cdot P \\ &= a_1 \cdot a_4 L^3 \\ T &= a_5 L^3\end{aligned}\tag{5.23}$$

where

$$a_5 = a_1 \cdot a_4 = a_1 \cdot a_2 \cdot a_3$$

The ship capability to progress in standard level ice conditions can be obtained from a resistance equation such as:

$$R = C_o \rho_i g B h^2 + C_1 B \sqrt{h/g} \sigma v\tag{5.24}$$

Therefore, the maximum level ice thickness may be obtained by substituting $v = 0$ and $R = T$ in the above equation resulting in:

$$h \leq \sqrt{T / (C_o \rho_i g B)}\tag{5.25}$$

where

$$C_o = 0.727 \mu_{12}^{0.965} (L/B)^{1.036} (\tan \gamma_o)^{0.332} (\cos \beta_5)^{-0.678}$$

and is a constant depending on the hull geometry and friction coefficient.

Substituting equation (5.23) into (5.25), the maximum thickness is obtained:

$$h = \sqrt[3]{\frac{a_5 L^3}{C_o \gamma_i B}} \quad (5.26)$$

$$h = a_6 L^{1.5}$$

where

$$a_6 = \sqrt[3]{a_5 / [C_o \gamma_i B]}$$

or

$$L = \left(\frac{1}{a_6}\right)^{2/3} h^{2/3} \quad L = a_7 h^{2/3} \quad (5.27)$$

where

$$a_7 = \sqrt[3]{(C_o \gamma_i B) / a_5}$$

Now, let us examine values of ice pressure according to various classification society rules. In the Canadian ASPPR design pressure is given in tabular form as a function of the ice class. It is implicit that the ice class represent the maximum ice thickness, in feet, that the ship can penetrate continuously. Therefore, the governing parameter in this case is the ice thickness h .

The Russian Rules give ice pressures as function of the ship length L :

$$P = 1.412 L \left(1 + \frac{2L}{1000}\right) a^{4/5} \mu_1 \quad \text{for the bow} \quad (5.28)$$

$$P = 9.8 (L - 15), \quad \text{for midship and aft}$$

Substituting (5.27) into (5.28) obtain

$$P = 1.412 a_7 h^{2/3} \left[1 + \frac{2a_7 h^{2/3}}{1000}\right] a^{4/5} \mu_1 \quad (5.29)$$

$$P = 9.8 (a_7 h^{2/3} - 15)$$

Equation (5.29) provides a direct relationship between ice thickness and the Russian design pressures. However, the ice thickness should be substituted in metric units. Typical values of hull angles at 0.1 L must be determined to calculate μ_1 and solve Equation (5.29).

The Finnish-Swedish rules and Johansson's criteria use the following formulas to calculate design pressures:

$$P = C_1 + C_2 K \quad (5.30)$$

where

$$K = \frac{\sqrt{\Delta P}}{1000} \quad (5.31)$$

C_1 and C_2 are constants which have different values for different classes of ships and various hull sections. Substituting (5.21) and (5.22) into (5.31):

$$K = 10^{-3} \sqrt{a_3 a_4} L^3 \quad (5.32)$$

Using (5.27) in (5.32), then substituting it back into (5.30):

$$K = 10^{-3} \sqrt{a_3 a_4} \cdot a_7^3 h^2 \quad (5.33)$$

$$P = C_1 + C_2 (a_7^3 \sqrt{a_3 a_4} 10^{-3}) h^2 \quad (5.34)$$

Equation (5.34) establishes the relationship between pressures estimated by the Finnish-Swedish rules and the ice thickness.

Using the MV ARCTIC as an example of a typical Arctic Class cargo carrier, the coefficients calculated using the above equations are shown in Table 5.11. The "design pressures" derived above have been calculated as a function of ice thickness, and are shown in Table 5.12. As shown, even for similar ice thicknesses, there are significant differences in design pressures for the various rules. For ice thicknesses of less than 4.5 ft the Canadian ASPPR are the most conservative criteria. For higher thicknesses, however, the Finnish-Swedish Rules are the most conservative, if the extrapolation of pressures used in this analysis is considered valid.

5.7 Comparison of Relative Steel Weights and Fabrication Costs

The effects of various ice strengthening criteria on the structures of the three representative ships were assessed through a comparison of relative steel weights and fabrication costs. Midbody shell structures were designed for each set of required scantlings as shown in Appendix B-1 and the weights and costs per unit area were calculated. The percentage increases in weight and cost above ABS+AI were then calculated for each ice strengthening criteria. Results are presented in Appendix B-4 of Volume II. Several limitations in this analysis should be noted. First, only shell structures in the midbody area were considered; supporting structures and the bow and stern structures were not included. Second, no attempt was made to optimize the designs with respect to frame and support spacing; the basic ABS rule frame spacings were used unless changes were required by the particular ice strengthening criteria under consideration. Third, the application of higher strength steels to reduce weight and possible cost was not considered.

TABLE 5.11 TYPICAL ICE CLASS CARGO SHIP DATA

MW ARCTIC		$L = 196.59 \text{ m}$ $B = 22.86 \text{ m}$ $D = 10.93 \text{ m}$ $\Delta = 38,309 \text{ t}$ $P = 14,770 \text{ BHP}$ $T = 158.76 \text{ t (Bollard)}$ $C_o = 11.501 \text{ (Resistance coefficient)}$
DERIVED COEFFICIENTS		
$L/B = 8.60$ $B/D = 2.084$ $C_B = 0.759$ $C_o = 11.501$ $\alpha_1 = T/P = 10.75 \times 10^{-3} \text{ t/HP}$ $\alpha_2 = P/\Delta = 0.386 \text{ HP/t}$	$a_3 = \gamma_w C_B / [(L/B)^2 (B/D)] = 4.92 \times 10^{-3} \text{ t/m}^3$ $a_4 = a_2 a_3 = 1.90 \times 10^{-3} \text{ HP/m}^3$ $a_5 = a_1 a_4 = 20.43 \times 10^{-6} \text{ t/m}^3$ $a_6 = \sqrt{a_5 / (C_o \gamma_w B)} = 278.8 \times 10^{-6} \text{ m}^{-1/2}$ $a_7 = 1/a_6^{2/3} = 234.3 \text{ m}^{1/3}$	

DEFINITIONS

- g = gravitational constant
- ρ_w = mass density of water
- ρ_i = mass density of ice
- h = ice thickness
- C_1 = experimentally defined constants
- σ = ice strength
- v = ship velocity
- Y = hull form coefficients
- μ_{12}

TABLE 5.12 EQUIVALENT DESIGN PRESSURES IN VARIOUS CRITERIA

ASPPR Arctic Class	h (ft)	RULE DESIGN PRESSURE, psf								
		Bow			Mid-body			Aft		
		a	b	c	a	b	c	a	b	c
1	0.98	249.47	223.36	127.63	100.08	127.63	91.37	100.08	127.63	72.52
1A	0.98	400.30	223.36	127.63	259.62	127.63	91.37	324.89	127.63	72.52
2	1.97	600.46	390.15	237.86	400.30	216.11	123.28	500.38	216.11	91.37
3	2.95	799.16	549.69	422.06	529.39	288.63	176.95	659.92	288.63	124.73
4	3.94	999.31	709.24	680.23	659.92	355.34	250.92	819.46	355.34	169.69
6	5.91	1199.46	1028.32	1415.57	749.85	471.37	462.67	939.85	471.37	301.68
7	6.89	1399.62	1190.76	1900.00	849.92	525.04	600.46	1050.08	525.04	387.25
8	7.87	1499.69	1354.65	2451.14	950.00	575.80	758.55	1199.46	575.80	484.43
10	9.84	1499.69	1686.79	3770.99	950.00	671.53	1140.00	1199.46	671.53	720.84

- a) ASPPR regulations
 - b) Soviet, Polish, Yugoslavian and Bulgarian Regulations (Class YAA)
 - c) Finnish, Swedish, and DNV regulations (Class IA Super)
- (The specified upper limits of pressure are ignored and linear extrapolation is assumed)

The results shown in Appendix B-4 of Volume II were developed as follows. First, a stiffener size was calculated for each combination of plating thickness and section modulus. These calculations used normal shipbuilding practice, with the effective width of plating equal to 60t or the stiffener spacing, whichever was less, and with stiffener sizes limited to standard rolled shapes or built-up sections. Each panel was "optimized" to provide minimum weight, but the lightest commercially available rolled shape usually had more strength than was required. This means that the actual design is usually heavier than the best theoretical design which could be developed using a fictitious stiffener. The weight per square foot was then calculated for each of the base cases (ABS + AI) and for each of the variations. The "percentage change in weight" is the ratio of these weights per square foot and is, therefore, applicable to any extent of structure. Finally, fabrication costs and the percentage change in costs were calculated. Shipbuilding structural costs are usually estimated on a "per pound" basis, with different values for different materials. Normally, such second-order effects as number of members, structural complexity, weld design, etc. are not well defined when the cost estimate is prepared so the cost per pound is based on average values. In this study, however, allowance has been made for such effects. The tabulated values for "percentage change in cost" are, therefore, on a "per square foot" basis and apply to any extent of structure. They are based on medium steel plating and stiffeners.

A graphical summary of steel weights for the three ships is shown in Figure 5.16. As illustrated in Appendix B-4, percentage increases in costs are about identical to percentage increases in steel weight and will, therefore, not be discussed separately. Increases in steel weights due to ice strengthening can be very large, as evidenced by the 533% increase for POLAR STAR designed to Canadian Arctic Class 10. It should be noted however, that the increase in weight can be reduced by reducing the frame spacing. Also, as ship size increases, the percentage increase in steel weight above the ABS rule value decreases. This is due to the fact that standard rules require heavier plating and framing for larger ships, while most of the ice strengthening criteria either specify a pressure which is not a function of ship size or set upper limits for the required scantlings.

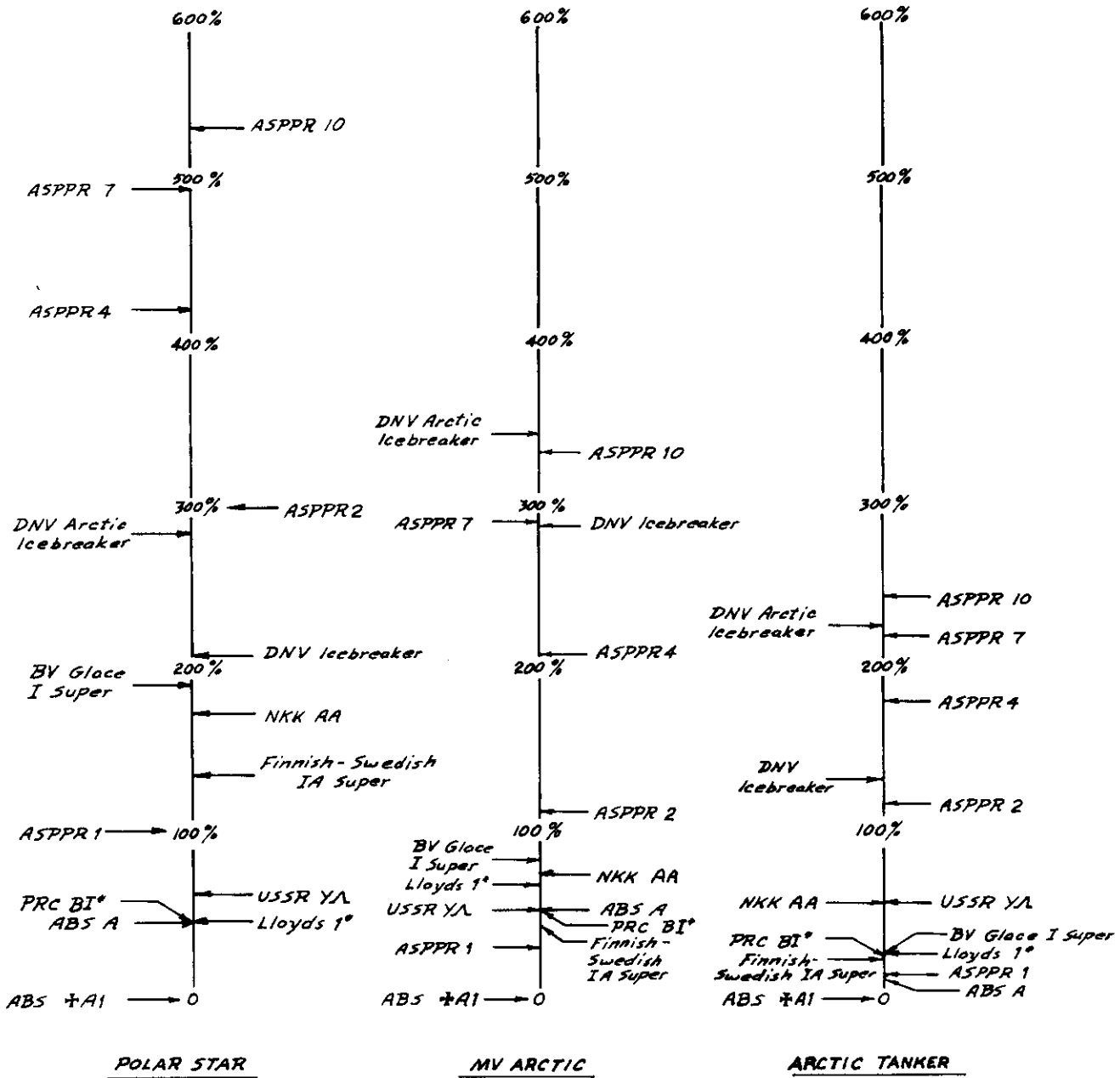

Figure 5.16 Percentage Increases in Steel Weights Above ABS +A1 for Ice Strengthened Midbody Panels

6. EXPERIENCE OF ICE-CLASSED SHIPS

Information on the experience of ice-classed ships was sought on two levels--specific damage incidents and general overall experience. Johansson [G-9] was able to collect specific ice damage data. His interpretations of the data and the techniques he advocated have been incorporated directly and/or indirectly into several of the sets of criteria in use.

6.1 Specific Ice Damage

Appendix C of Volume II describes an analysis method to infer ice loads from a study of ice-inflicted damage.

With the exception of the photograph in Figure 6.1 and a survey report of the damage to the MV ARCTIC, no significant specific damage data were obtained.

The MV ARCTIC is a 28,000 DWT bulk carrier designed to the Canadian Arctic Shipping Pollution Prevention Regulations as an Arctic Class 2 ship. It normally operates on a year-round basis from Nanisivik Northwest Territory to Antwerp, Belgium, carrying ore. It is interesting to note that the precise moment of the damage was not noted; the impact which did the damage went unnoticed. It is presumed to have occurred on or before 17 October 1978 when a list developed. The ice conditions are unknown, but on the 17th there was relatively open water and growlers were known to be present. The damage, a ripped, gapping hole about 25 ft long and 5 ft high on the starboard side, is shown in Figure C.5 which was adapted from Laskey [G-11]. There is a claim that the failure was a brittle crack. Under brittle failure conditions, the full elastic-plastic strength of the material is not developed.

6.2 General and Fleet Experience With Ice-Classed Ships

Some of the observations in this category tend to be qualitative rather than quantitative. However, in the following cases, the experience is extensive and the subjective evaluations and comments seem to be worthwhile.

6.2.1 U.S. Coast Guard Icebreakers

The WIND Class icebreakers were originally designed around 1940 with 1-5/8" HTS shell plating; the original framing design would withstand an ice loading of approximately 150 psi (elastic design). This combination resulted in many structural failures, always of the frames. Through the years, the WIND CLASS frames were strengthened so that they would withstand an ice pressure of approximately 300 psi and the incidence of hull failures was greatly reduced. However, the failures still involved collapse or instability of the frames.

The Coast Guard designed the POLAR Class with 1-7/8" high yield steel plating and the framing for 600 psi (elastic design). Particularly careful attention was devoted to structural details such as connections, haunches, fit, etc. Thus far, the structures of these two ships have not had any failures.

The Catcus Class icebreaking buoy tenders of around 980 tons displacement were designed in 1942 with 3/4" mild steel plate supported by frames which would



Figure 6.1 MV Arctic Ice Damage, October 1978

withstand about 80 psi (elastic). Most of these ships are still in service, having recently undergone machinery and habitability renovations. They have been used for icebreaking in the northeastern U.S. harbors, the Great Lakes, and occasional summer voyages to the Arctic (both eastern and western). There has been very little ice damage to the structure.

6.2.2 Military Sealift Command Experience

The Military Sealift Command has had responsibility for marine logistics support of the U.S. Antarctic Deepfreeze Expeditions. Most of the ships used in that service were originally standard merchant ship designs which would withstand pressures around 60 psi. These ships suffered considerable ice damage and have subsequently either been strengthened to what is essentially equivalent to ABS ice class IB or IC or have been replaced with ships designed to be "ice strengthened". The strengthening was accomplished by doubling the plating and reinforcing the framing to support about 240 psi design pressure. The ships have not been formally given any ice class by ABS. These ships are frequently escorted through the Antarctic pack by icebreakers at the beginning of the Antarctic summer. The operation in close company with icebreakers in heavy ice, does still lead to structural damage, sometimes of a spectacular nature. However, these incidents are fairly rare and the view is that the structure of these ships is performing adequately.

6.2.3 Great Lakes Season Extension Experience

Naval architects and fleet managers on the Great Lakes have faced a unique ice strengthening problem in terms of the environment and of the ships themselves. The crushing strength of fresh water ice may be four times that of sea ice, and impacts with fast ice and medium-sized floes up to 4 ft thick have caused damage to ships every winter operating season. In addition to the harsh Great Lakes winter environment, most Great Lakes bulk carriers are wall sided and have 90° bow stem angles which make them more vulnerable to ice damage than ocean-going ships. The ABS and U.S. Coast Guard requirements for longitudinal strength are about one-half of that required for ocean-going ships because wave bending is not as severe on the Great Lakes. This fostered the development of a fleet of ships substantially weaker than ocean-going ships until recently, when the economic issues of extending the shipping season have been studied. Although the ABS Ice Classifications for ice transiting vessels are recognized on the Lakes, ships are not specifically built to these ice class specifications because no definite correlation between ice classification and resistance to ice damage has been formulated. Instead, ice strengthening is a specialty item, added at the owner's request and specified by experience.

Ice strengthening usually occurs only on the bow, between light and loaded waterlines, and is accomplished by increasing the scantlings, changing to higher yield strength steels, or both. Ships designed for ice-free operations usually incorporate 36,000 psi yield strength steel in their bow structures, whereas ships designed to operate for longer seasons incorporate 46,000 psi yield strength steel and increased scantlings. Table 6.1 lists and summarizes the bow structure of ten Great Lakes bulk carriers including all existing 1000 ft ships. The technical information for this table was compiled by Marine Consultants and Designers, Incorporated, directly from the files of the fleet operators. (A more complete description of each ship's structure can be found in Volume III of the MarAd report, "Ship Designs for Maximizing Utilization of

TABLE 6.1

POWERING AND BOW STRUCTURE SPECIFICATIONS* FOR TEN GREAT LAKES VESSEL

<u>NAME</u>	<u>DISPLACEMENT (L.T.F.W.)</u>	<u>BHP</u>	<u>BOW ICE BELT PLATING**</u>	<u>BOW ICE BELT VERTICAL CANT FRAME SPACING AND TYPE*</u>
EDWIN H. GOTT	75,500 @ 27'6"	19,500	3/4", A514	20 1/2", A514
GEORGE A. STINSON	76,321 @ 28'0"	16,000	13/16", AH32	24", AH36
JAMES R. BARKER	76,321 @ 28'0"	16,000	13/16", AH32	24", AH36
MESABI MINER	76,321 @ 28'0"	16,000	13/16", AH32	24", AH36
LEWIS WILSON FOY	75,550 @ 27'6"	14,400	3/4", AH36	20 1/2", AH36
BELLE RIVER	75,550 @ 27'6"	14,400	3/4", AH36	20 1/2", AH36
PRESQUE ISLE	75,720 @ 28'0"	14,840	7/8", Gr. A	24", Gr. A
STEWART J. CORT	74,400 @ 27'10"	14,400	7/8", Gr. B	24", Gr. B
ROGER BLOUGH	62,000 @ 27'11"	14,200	13/16", Gr. A	24", Gr. A
HENRY FORD II	13,000 @ 22'4"	3,000	5/8", Gr. B††	18", Gr. A†

6-4

** A514 (Includes USS T-1A, Bethlehem Steel RQ-100A, ARMC0 SSS-100, Great Lakes Steel NA-X
 AH32 - 45,000 psi yield
 AH36 - 51,000 psi yield
 Gr. A - 34,000 psi yield
 Gr. B - 34,000 psi yield

* It is interesting to note that the bow structures on Great Lakes bulk carriers are usual to meet any specific design pressure minimums for impact loading. Although the EDWIN H structure meets the requirements for ABS ice class 1A, the suitability of ABS ice class the Great Lakes is unknown.

† 8" x 4" x 1/2" angle, transverse frames, not cant frame.

†† Strengthened to 5/8" A514 during winter of 1973-74.

Great Lakes Waterways".) Most recently, 100,000 psi yield strength steel has been used for plating and framing with great success. The HENRY FORD II, originally built in 1924, was ice strengthened by replacing her bow plating with 5/8" USS T-1A (U.S. Steel's 100,000 psi yield strength steel, ASTM A514). The HENRY FORD II traditionally transported coal from Toledo to Ford Motor Company's River Rouge Plant in Detroit through ice conditions severe enough to double round trip times and necessitate tug support. Prior to the plating replacement, the old plating showed extreme washboarding and deformation. Ford's Director of Marine Operations, Mr. John Nye, has been very pleased with the performance of the new plating, which has suffered no damage in several years of service. Fleet managers for U.S. Steel, whose ships have seen more winter service than any other fleet, have stated their confidence in using A514 steel for ice strengthening. U.S. Steel's recently built 1,000 ft EDWIN H. GOTT uses A514 for ice-belt plating in the bow and stern and also uses A514 cant frames and transverse frames. On the GOTT's maiden voyage in unusually severe ice, a ballasting and trimming problem caused the bow to ride much higher than normal, resulting in washboarding of plating below the ice belt while the A514 ice belt remained unscathed. (During the same voyage, an accompanying ship punctured her bow and flooded her forepeak.) Additional construction costs due to ice strengthening a 1,000 ft Great Lakes bulk carrier during construction are as follows (costs valid 6/79):

Ice Strengthening Forward: Change shell plate and stiffeners from AH36 to A514 steel at same thickness between the 17'-6" and 34'-7" waterlines from stem to a point 160 ft after the stem \$ 57,000

Ice Strengthening Midbody: Change shell plate from AH 36 to A514 steel at same thickness from a point 160 ft aft of stem to a point 50 feet forward of transom between the 18'-3" and 32'-10" waterlines \$150,000

Ice Strengthening Aft: Change shell plate from AH36 to A514 steel at same thickness from a point located 50 ft forward of the transom to a point located 24 ft forward of the transom between the 25'-6" and 40'-2" waterlines \$ 5,000

Figure 6.2 details the main structural differences between the ice strengthened EDWIN H. GOTT and the non ice strengthened BELLE RIVER. The comparison is particularly significant because both vessels share the same set of lines and principal characteristics. These two ships represent the most modern ships on the Lakes intended for extended season (the GOTT) and normal season operations (the BELLE RIVER). Application of the method used by Johansson [B-16] to analyze ice damage data indicates that the bow plating of the EDWIN H. GOTT will withstand a uniform load of 576 psi, 800 mm high, and the bow of the BELLE RIVER will withstand 294 psi prior to the development of plastic hinges in the plating.

An alternative or addition to ice strengthening (particularly on planned 1,000 ft bulk carriers) would be to angle the bow stem to allow the ice to break in flexure rather than compression. This approach has one drawback in that it decreases the cargo deadweight by 0.2%. However, as Figure 6.3 shows, changing the bow stem angle may decrease ice impact forces by 70.0%.

Figure 6.2 Structural Differences Between the Edwin H. Gott and the Belle River

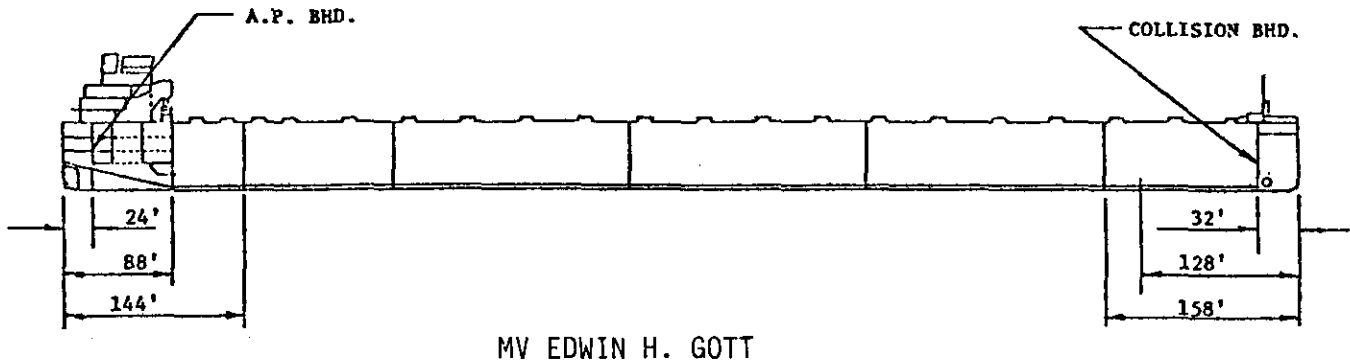

FOREBODY FRAMING:

Stem to Collision BHD (32' Aft of Stem) Between 2nd DK. and 17' W.L.
 Cant Frames- 9" x 4" x 1/2" Angle, T-1A, Spaced 20-1/2"
 Collision BHD to Frame 17 (128' Aft of Stem) Between 34' W.L. and 17' W.L.
 Transverse Frames - 9" x 4" x 1/2" Angle, T-1A, Spaced 19.2"
 Frame 17 to About 3' Forward of Frame 21 (158' Aft of Stem) Below 34' W.L.
 Longitudinal Frames
 Above 19' W.L. 8" x 4" x 7/16" Angles, T-1A Spaced 29-1/4"

PLATING THICKNESS

Forward Ice Belt: Stem to 158' Aft of Stem
 Between 34'-7" and 17'-6" W.L., 3/4" T-1A Steel
 Aft Ice Belt : Side Shell From 50' Fwd of
 Transom to 8' Fwd of Transom
 Below 40' W.L. 3/4" T-1A Steel

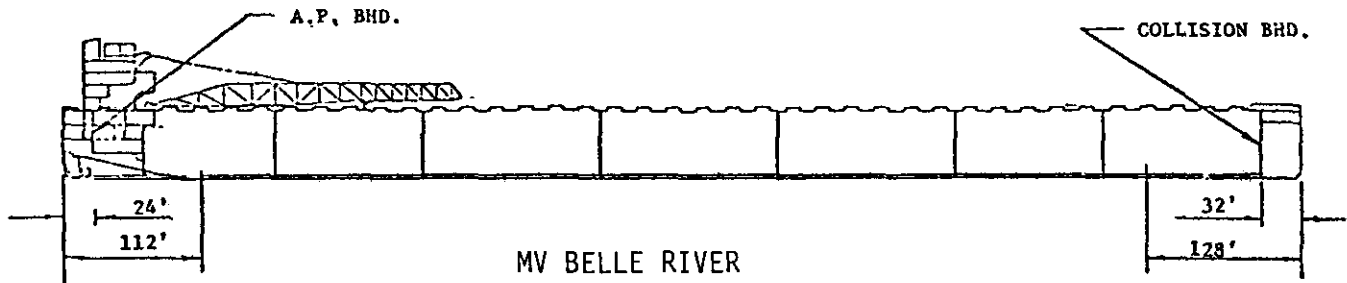

FOREBODY FRAMING

Stem to Collision BHD (32' Aft of Stem) Between 2nd DK. and 18' W.L.
 Cant Frames 9" x 4" x 1/2" Angle, AH-36, Spaced 20-1/2"
 Collision BHD to Frame 17 (128' Aft of Stem) Between Hopper Slope and 18' W.L.
 Transverse Frames - 9" x 4" x 1/2" Angle, AH-36, Spaced 19.2"

PLATING THICKNESS:

Side Shell	3/4", AH36 Steel
Transom Corner Plate	1" "
Bilge Strake Forward and Midships	3/4" "
Bilge Strake Aft	5/8" "
Skeg Side Shell	9/16" "
Transom	7/16" "
End of Skeg	1" "

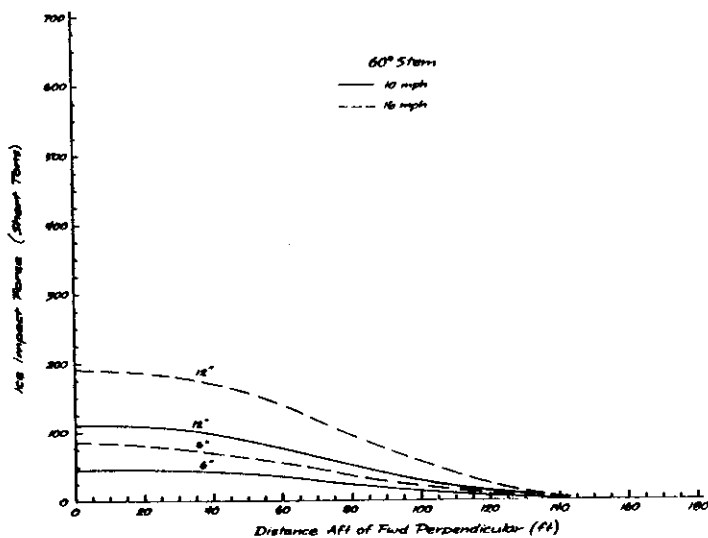
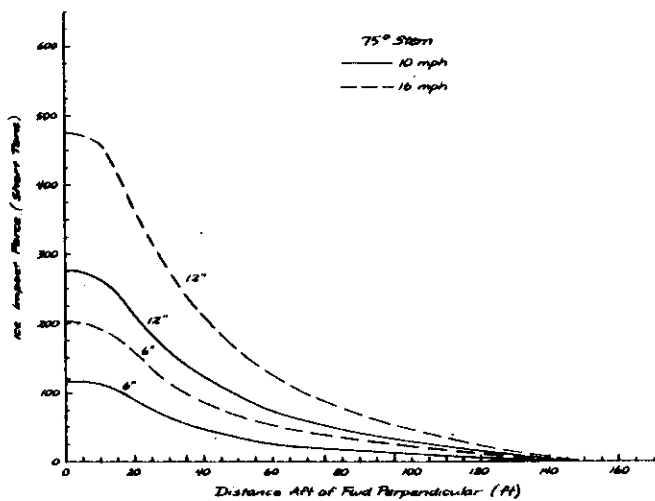
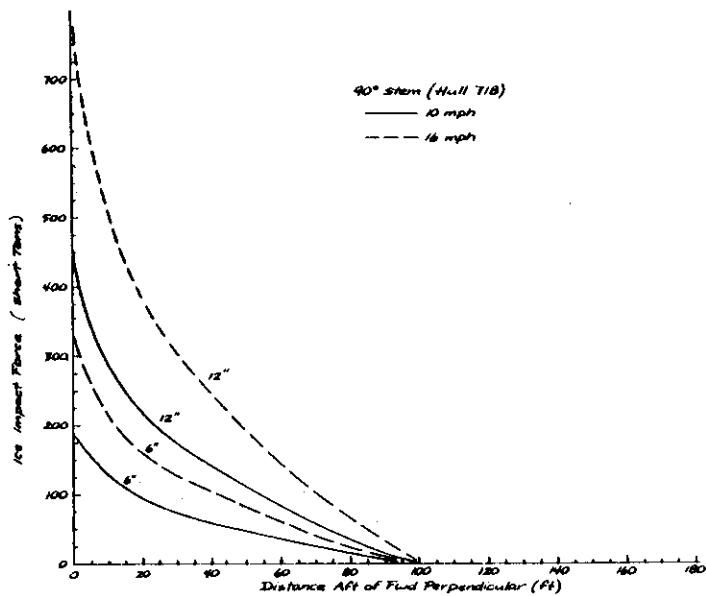

Figure 6.3. Predicted Ice Impact Forces on Hull vs. Distance from F.P. for 12 inch and 6 inch Level Ice

6.2.4 Canadian Statistical Records of Ice Damage

Records of vessel casualties in Canadian waters as reported to the Ministry of Transport (MOT) during 1966 to 1978 inclusive were obtained. These records were examined and analyzed statistically to determine as much as possible about the frequency of ice damage to ships as a function of:

- Various ice classing or strengthening
- Vessel type
- Zone in which damage occurred
- Time of year where damage occurred

Such records only provide abstract data which can be used to draw statistical values. However, they do not give sufficient information to conduct a damage analysis at any level. Therefore, in this section, we will present the results of analyzing a total of 196 damage incidents statistically.

Figure 6.4 illustrates the relative frequency of ice damage to ships (in Canadian waters, 1966-1978) according to their ice class or strengthening. Note that approximately 50 percent of ice damage incidents were associated with non-strengthened ships. Comparisons between the strengthening requirements for various ice classes may be found elsewhere in the report.

The relationship of ice damage to the type of vessel is shown in Figure 6.5. More than 70 percent of the reported ice damage incidents occurring between 1966 and 1978 involved general cargo ships, bulk carriers, and tankers. Most of these incidents, approximately 96.4%, occurred to smaller vessels having 30,000 L. tons or less. More than 50% of the ships with inflicted ice damage were 6000 L. tons or below. The distribution of damage incidents according to ship tonnage, for all types, is described in Figure 6.6. The figure shows three histogram representations which are based on different intervals and tonnage range. The trend is clearly that the smaller the tonnage, the higher the incidence of ice damage. Interpretation of this, however, is difficult since there are no data which report the exposure to potential ice damage; for example, the number of miles steamed in the presence of ice as a function of ship size.

The time of the year where most damage occurred was also examined. Figure 6.7 shows the distribution of damage incidents for the 13 years under investigation. These are, again, *reported* damage incidents in Canadian waters. The damage incidence is directly connected with the ice year; i.e., in a "bad" ice year the likelihood of damage increases and vice-versa. When unfavorable ice conditions prevail, the possibility of ice damage can extend through the summer months, while early breakup and clearing reflect on the absence of damage incidence during summer as is the case in 1972 and 1975. It should also be noted that early in the period under consideration a smaller number of damage incidents was attributed to ice. This reflects the recent increase in demand for marine transportation in the presence of ice.

Over the entire period, an *average* histogram shows that the probability of damage peaks in April, and it is generally highest in January through March (winter months). November is a month with the best record for almost no ice damage occurrence (except once in 1978 involving the Canadian Coast Guard ice-breaker JOHN A. MACDONALD which suffered bow damage during its transit between Resolute and Tuktoyaktuk).

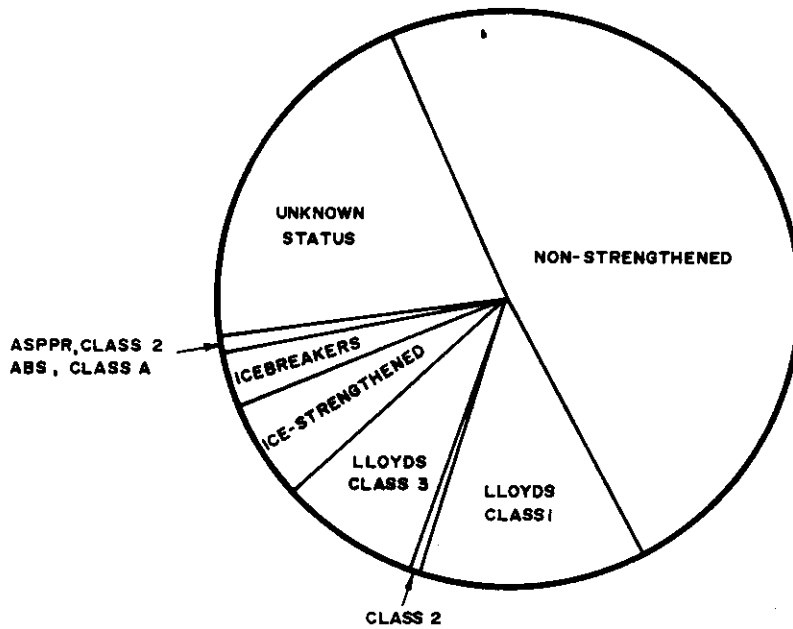

Figure 6.4 Relative Frequency of Ice Damage to Ships with Various Ice Classing - Casualties in Canadian Waters (1968 - 1978)

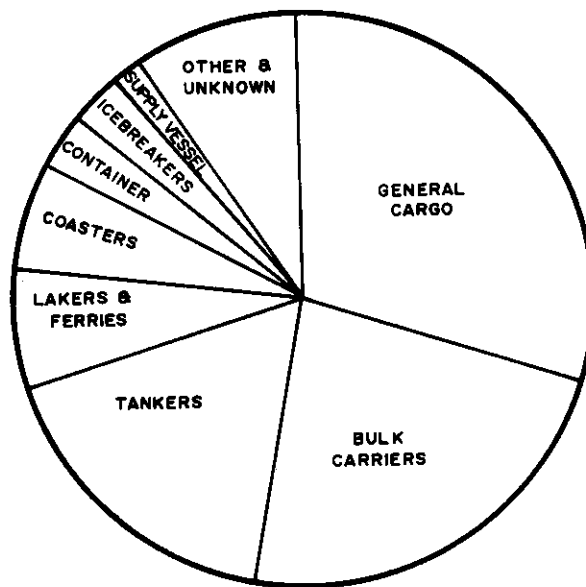
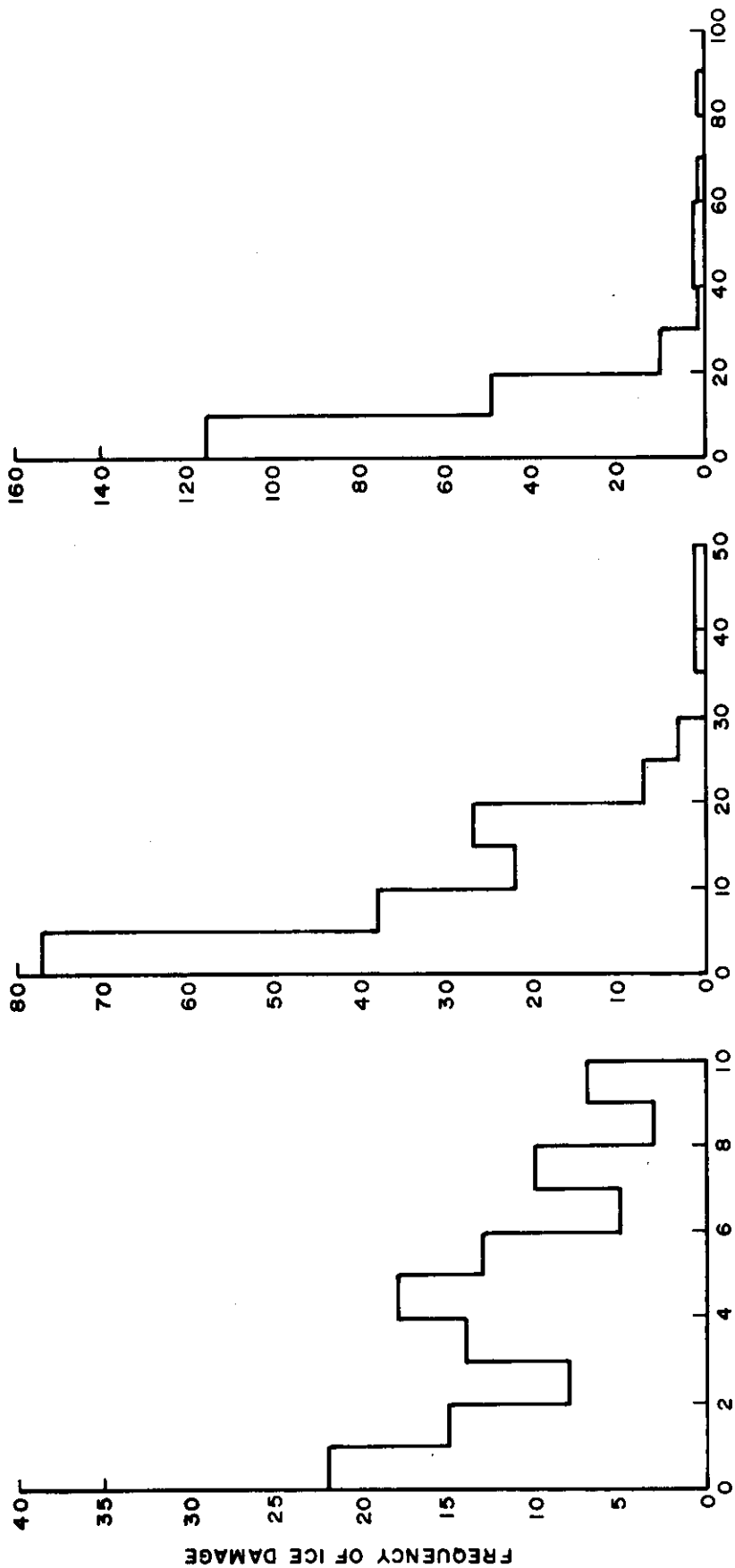
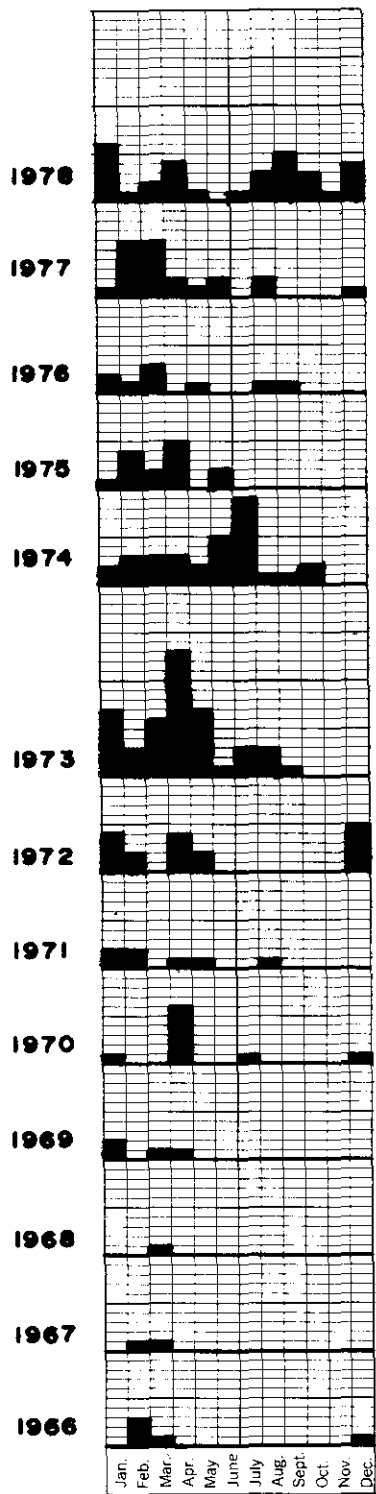

Figure 6.5 Relative Frequency of Ice Damage for Different Types of Ships (1966 - 1978)



GROSS TONNAGE, IN THOUSANDS OF TONNES

Figure 6.6 Histogram Showing Distribution of Damage Incidents According to Ship Tonnage



DISTRIBUTION OF
DAMAGE INCIDENTS
YEAR ROUND FOR
EACH YEAR 1966-78

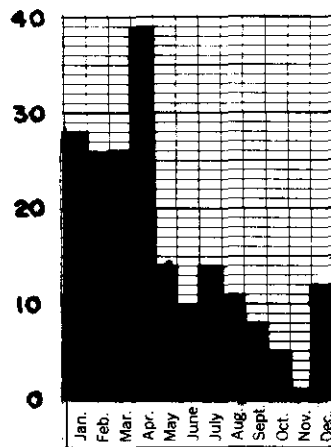

DISTRIBUTION OF
DAMAGE INCIDENTS
YEAR ROUND -TOTAL
1966-1978

Figure 6.7 Distribution of Damage Incidents Per Time of Year

Most incidents occurring during the winter months are confined to sub-Arctic waters while summer months (until November) are associated with northern activities (drilling, mining, supply, and support operations, etc.). This, of course, is proportional to the frequency of marine operations in the presence of ice. The months of June and July in 1974 are an exception where a large number of damage incidents (14) occurred in the Strait of Belle Isle and Hamilton Inlet off Labrador coast and were mainly associated with a "bad" ice year.

A review of the geographic vicinity where damage occurred gives the following statistics for the total number of incidents:

St. Lawrence River and Seaway	55
Gulf of St. Lawrence	30
Off Coast - Newfoundland	30
Off Coast - Labrador	19
Strait of Belle Isle	7
Other Sub-Arctic Locations	28
Arctic Locations	<u>27</u>
Total (1966 through 1978)	<u>196</u>

An attempt was made to compare the actual class of damaged ships and the minimum Arctic class requirement according to ASPPR for the time of the year and ice zone where damage was reported. A total of 25 incidents were analyzed and the results are reported in Table 6.2.

While it is not surprising to expect a higher incidence of damage to non-strengthened ships (one third of the cases reported in Table 6.2), it is important to note that ships with supposedly adequate strengthening suffer ice damage while operating in the proper season and within the boundaries of designated ice zones. The latter incidence constitutes 40 percent of the cases reported in Table 6.2. In the remaining 28 percent of the cases, there is not sufficient data to determine whether the damaged ship was sufficiently strengthened or not (according to ASPPR criteria). However, we are inclined to interpret this percentage in the category of inadequate strengthening; i.e., increasing its proportion to 60 percent of the 25 cases studied.

The nature of casualties reported due to ice was mainly damage of various extents to the ship hull. Listed below is a statistical account of the reported damage categories due to ice:

- 107 Incidents of hull damaged divided as follows:

- Bow holed or damaged	66
- Stern damage	2
- General damage to shell plating, may include bow or stern cases	39

(In 5 cases, collision with icebergs was reported)

- 39 Incidents in which ships were forced aground or ashore, and in some cases, severe bottom damage was inflicted.

TABLE 6.2 SELECTED DAMAGE INCIDENTS FOR ICE CLASSED SHIPS IN CANADIAN WATERS (1970-1978)

DATE OF REPORTED DAMAGE		ASPPR ZONE OF REPORTED DAMAGE	ACTUAL LLOYD'S ICE CLASS	MINIMUM ICE CLASS REQUIREMENT		STRENGTHENING		
YEAR	TIME			ASPPR	EQUIVALENT LLOYD'S	Adequate	Inadequate	Unknown
1970	31 July	Zone 13	Unknown	Type D	Class 3			✓
1971	18 Aug.	Zone 9 or 10	0	Type D	Class 3		✓	
1973	30 July	Zone 15	Unknown	Type E	100A1			✓
	11 Aug.	Zone 15	3	Type E	100A1	✓		
	5 Sept	Zone 13	0	Type E	100A1		✓	
	12-13 July	Zone 15	1	Type D	Class 3	✓		
	17-27 July	Zone 15	0	Type D	Class 3		✓	
	1 Aug	Zone 15	Unknown	Type E	100A1			✓
1976	20 Sept	Zone 15	0	Type E	100A1		✓	
	20 Aug	Zone 9 or 10	0	Type E	100A1		✓	
1977	1 Aug	Zone 4 or 12	1	Class 2	?			?
	12 Aug	Zone 7	1	Type E	100A1	✓		
1978	21 July	Zone 4	Strengthened	Class 3	?			?
	11 Aug	Zone 9	Non-strengthened	Type C	Class 2		✓	
	23 Aug	Zone 13	1	Type E	100A1	✓		
	29 Aug	Zone 10	Icebreaker	Type E	100A1	✓		
	10 Sept	Zone 7	Icebreaker	Type E	100A1	✓		
	10 Sept	Zone 13	Strengthened	Type D	Class 3			?
	13 Sept	Zone 8	Icebreaker	Type C	Class 2	✓		
	21 Sept	Zone 6	1	Type C	Class 2	✓		
	24 Sept	Zone 8	Strengthened	Type E	100A1			?
	2 Oct	Zone 14	Non-strengthened	Type E	100A1		✓	
	17 Oct	Zone 9 or 13	ASPPR Class 2	Type D	Class 3	✓		
	23 Oct	Zone 10	Non-strengthened	Type C	Class 2		✓	
	23 Nov	Zones 6,11,12 or 13	Icebreaker	Class 3	?	✓		

6-13

- 26 Incidents in which damage was inflicted on propellers, rudder stock or steering gear in the following proportion:

- Propeller damage	13
- Rudder stock twisted or sheared	9
- Steering gear damage	3
- Other	1

- 10 Incidents of collision with other ships in ice or due to ice conditions including some cases of collision with icebreakers.

- 8 Incidents in which damage was not specified or reported.

- 3 Incidents of total loss of vessels. (In three other incidents the vessels were extensively damaged and were reported sinking, one of them was an 89,536 ton cargo ship).

7. CRITIQUE OF CURRENT CRITERIA

It is not the intention of this report to find fault with each current rule or regulation pertaining to ice strengthening criteria. However, it is instructive to review those criteria in the light of the requirements for a rational basis for ice strengthening developed so far.

7.1 General Deficiencies

7.1.1 Failure to Relate Criteria to Specific Geographical Region and Season

Only the Canadian ASPPR require a specific level of strengthening for a specific time and location. The Canadian ASPPR approach is thorough but somewhat inflexible. The Finnish-Swedish Winter Navigation Board apparently publish seasonal advisories which limit operations in certain parts of the Baltic to specific ice classes. This does accomplish the same purpose and provides the flexibility to accommodate "hard" or "easy" ice years. The classification societies' approach is to allow the owner to select whatever classification he desires. This approach is consistent with the classification societies' overall role in serving owners. *In the case of ice strengthening, however, a criterion is not complete until the location and season are related to the degree of strengthening.*

7.1.2 No Requirements for Information to Refine Criteria

In view of all of the uncertainties associated with ice strengthening criteria, feedback of experience is essential to refine the criteria. Systematic collection of data defining exposure to various degrees of ice and of ice damage data would fulfill this requirement. The Canadian ASPPR requires reports of pollution or pollution threatening incidents only. The United States and Canadian governments (Department of Transportation and Ministry of Transport) require reports of damage to ships in general. The damage cause, "ice" in this case, is coded into the data base. However, the reporting requirements are not detailed enough to make the best use of ice damage data for the purpose of evaluating and refining the criteria. Neither the United States Department of Transportation nor the Canadian Ministry of Transport collect data from which the exposure to risk of ice damage may be inferred. *Some exposure index is essential to evaluate the effectiveness of criteria and regulations in the face of what may become an explosive increase in marine operations in ice-covered waters.*

It has not been the role of the classification societies to collect such information, especially since it would duplicate much of what is required by the various governments.

7.1.3 Absence of a Basis to Specify or to Infer the Reliability Inherent in Ice Strengthening Criteria

All of the existing criteria, which are clearly built on experience, are employing the evolutionary design method. The shortcomings of this method are described by Evans [E.8] and others. On the other hand, this method does lead to a comfortable sense of reliability provided:

- a) There is no departure from past design practices.
- b) The applications are limited to very small incremental extensions of the range of the experience base.
- c) No importance is given to optimizing the design.

In general, however, it is not possible to determine what, if any, safety factors have been applied in establishing the criteria. An approach to establishing ice strengthening criteria which does not attempt to evaluate individually and specifically all design factors involved is not satisfactory.

7.2 Assumed Distribution of Load for Frame Design

Johansson [B-16], whose work has influenced many of the current criteria, begins his development in terms of a general load on the frames. This is shown in Figure 7.1(a). The remainder of this development, however, is based on a specific assumption for the distribution of the load. He assumed the ice load was applied equally over 800 mm (2.6') at the mid-span of the frame as shown in Figure 7.1(b). This is quite a reasonable assumption for the Baltic Sea where the maximum level ice thickness is around 3 feet. The mid-span aspect of the assumption is a conservative "worst case".

Most classification societies (see Table 5.3) offer classifications based on the Finnish-Swedish rules, which are based on Johansson's work and incorporate this specific load distribution. Although these classifications are identified as specifically meeting the requirements of the Finnish-Swedish Winter Navigation Board, there is no guidance which indicates to the owner that the rationale behind these classifications is based only on Baltic Sea conditions. Thus, the load distribution which was reasonable for the Baltic may be unknowingly applied for other services, more or less arduous.

The Canadian ASPPR [C-11] specify frame strengthening based on a design pressure which increases with the nominal ice thickness. Table 7.1 is an excerpt of the Canadian ASPPR.

TABLE 7.1 ICE PRESSURE, BOW AREA

ARCTIC ICE CLASS	NOMINAL ICE THICKNESS (ft)	p^* (psi)
1	1.0	250
1A	1.5	400
2	2.0	600
3	3.0	800
4	4.0	1000
6	6.0	1200
7	7.0	1400
8	8.0	1500
10	10.0	1500

* Ice pressure for ice strengthening.

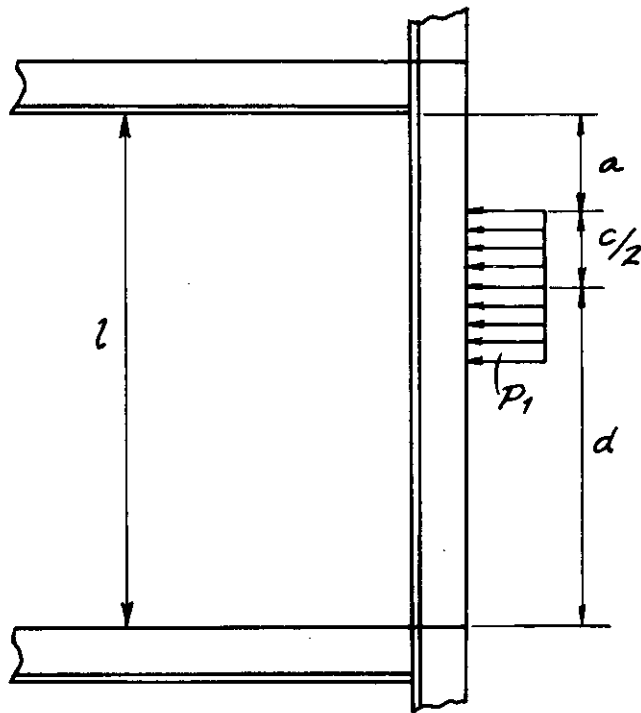

Figure 7.1(a) General Description of Load Distribution in Johansson's Method

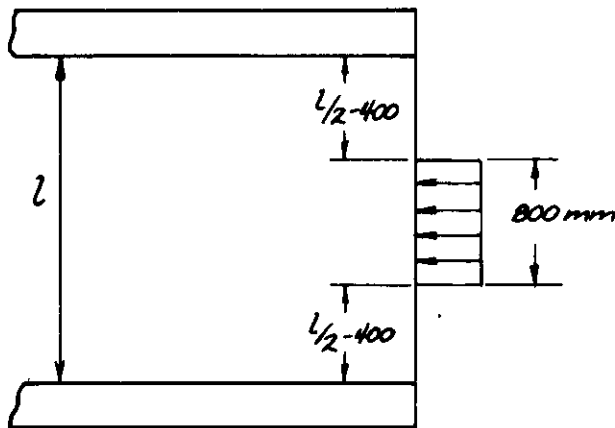

Figure 7.1(b) Form of Load Distribution Used by Johansson in Final Form

These design pressures are used in Equation 8(1) of the Canadian ASPPR [C-11] to determine the section modulus of main transverse frames:

$$\text{Section Modulus} = \frac{709 \text{ PS } (b - 1.31)}{f} \quad (7.1)$$

where

- P = Pressure in psi
- S = Main transverse frame spacing in ft
- b = Span of the main transverse frame in ft
- f = Yield stress of the main transverse frame material in psi

It can easily be shown that this is derived directly from Johansson [B-16] with a 1.25 safety factor and conversion factors. Implicit in this equation is the assumption that the ice pressure is spread equally over a height of 800 mm at the mid-span of the frame. This assumption is applied even though the nominal ice thickness may be as great as 10 feet. An alternative assumption is that the vertical extent of the ice pressure distribution should be proportional to the ice thickness. If this is true, and if the ice pressure is assumed to be constant independent of ice thickness (or ice class), an equation can be derived which will provide an equivalent ice strengthening. The relationship that satisfied this is

$$\text{Section Modulus} = 380 \frac{tpS}{f} (b - 1.5t) \quad (7.2)$$

Symbols are the same as above, except

- t = nominal ice thickness in ft
- p = pressure in psi, a constant 600 psi in this case
- S = frame spacing

The MV ARCTIC, as used for illustration in other sections, is used again here for comparison. In Figure 7.2, the section modulus for the MV ARCTIC is shown as computed by Equation 8(1)a of Ref. [C-11] and as computed by Equation (7.2) above.

The derived equation, (7.2), was forced to be equal to the Canadian ASPPR requirements at Class 2 and Class 10 and for the physical characteristics of the MV ARCTIC. This equation is not offered as the criterion for ice strengthening of frames. It was derived simply to illustrate *that equivalent ice strengthening of frames can be achieved by considering the extent (height) of the ice pressure as the independent variable, as well as considering the ice pressure itself as the independent variable.*

The USSR Register of Shipping Rules takes another approach to describing the distribution of the load. For frame strengthening, the USSR Registry specifies the load in terms of a concentrated line load at the mid-span. For the same total load and with other conditions equal, this causes a larger bending moment and thus specifies a larger frame section modulus. However, the USSR Registry Rules use an entirely different formulation for required section modulus and there is no true comparability (see the detailed comparisons made in Section 5).

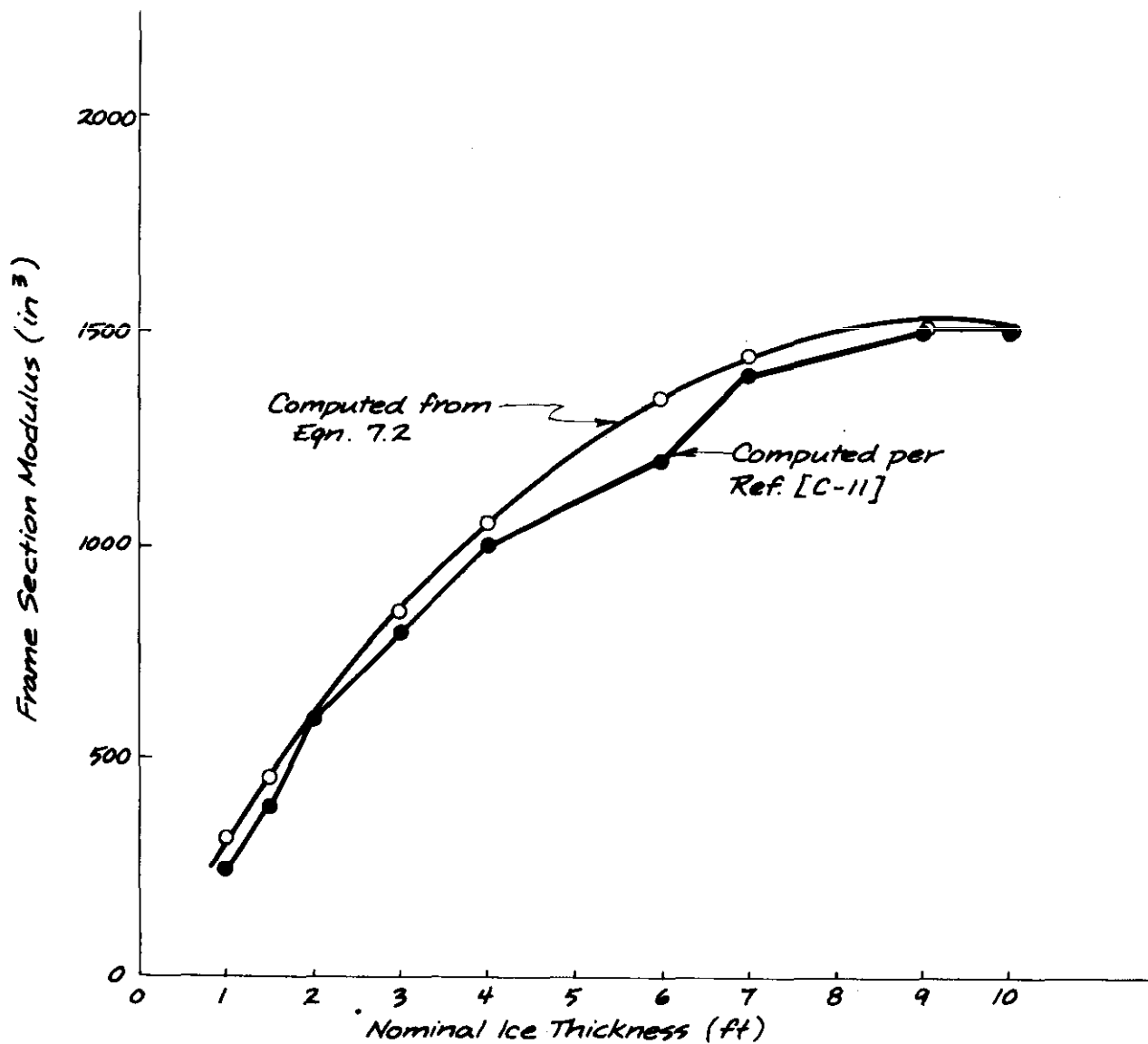

Figure 7.2 Comparison of Section Modulus for M V ARCTIC as Computed by Eq. 7.2 and in Accordance with Ref. (C-11)

7.3 Factors and Method Used to Determine Design Load

Johansson [B-16], through analysis of Lloyd's records of ice strengthened ships and ice damage, inferred a relationship between satisfactory ice pressure bearing capacity and a factor representing ship size and power. He must have intuitively believed that larger and more powerful ships required the ability to withstand greater ice loads. This report will not reconstruct his work, which was certainly the most rational approach to the problem at the time. Figure 7.3 is taken from reference [B-16]. In this figure, Johansson has plotted the computed value of each ship's ice pressure bearing capability, using the ship's designed scantlings and his plastic analysis, as a function of the dimensional term $\sqrt{\Delta} \cdot \text{SHP}$ for the ship. By coloring the points solid black for instances where ice damage was recorded, Johansson presents a third dimension.

Johansson's data are not at all conclusive. He admits in [B-16] that "drawing the line" is based on judgement and is quite difficult. Without a pre-conceived notion of a relationship, it would be hard to justify drawing any line defining a relationship. An obvious alternative criterion would be a horizontal line of $p \approx 14 \text{ kp/cm}^2$.

The Finnish-Swedish WNB accepted Johansson's approach but tempered the impact by requiring lower ice pressures than he recommended. Thus, the same approach is also included in all those classification society rules which have classifications designed to meet the Finnish-Swedish WNB's rules.

The intuitive feel that the ship size and power should be reflected in the ice strengthening persists. The rigid-body mechanics analysis described in Section 2 clearly indicates a relationship between ship speed and ice force. It follows that higher powers would produce greater speeds. However, the same analysis just as clearly indicates that there is little or no dependence on ship size for the same speed and ice conditions. The USSR Registry Rules [C-20] were obviously based on Popov, but the formulation obscures the detailed assumptions, analyses, etc. The ice strengthening required by Ref. [C-20] is strongly dependent on ship length and on the hull geometry at the bow. Ref. [C-20] is the only set of criteria which reflects the hull shape's ability to "glance" off the ice.

It is clear that the resistive component of force from the interaction between a ship's hull and ice is dependent on the hull geometry at the point of interaction. It is not clear whether the structural forces are similarly dependent as is implied by the USSR rules. Considering the random nature of small but significant ship motions while proceeding in ice, it seems that the angles between the hull and the ice vary unpredictably and a "worse case" should be used in structural design considerations.

7.4 Structural Analysis Methods and Response Criteria

As pointed out in Sections 2 and 5, Johansson applied elastic-plastic techniques in his approach. The many criteria based on his work also are based on elastic-plastic analysis. *Since the three plastic hinges are considered to form without any plastic deformation, this criterion does not account for the plating material's capability to withstand high membrane stresses.* Thus, the elastic-plastic, three-hinge method is conservative. However, this method's ease of application is a strong recommendation for its use.

Table 7.2 summarizes the more salient differences among the various ice strengthening criteria.

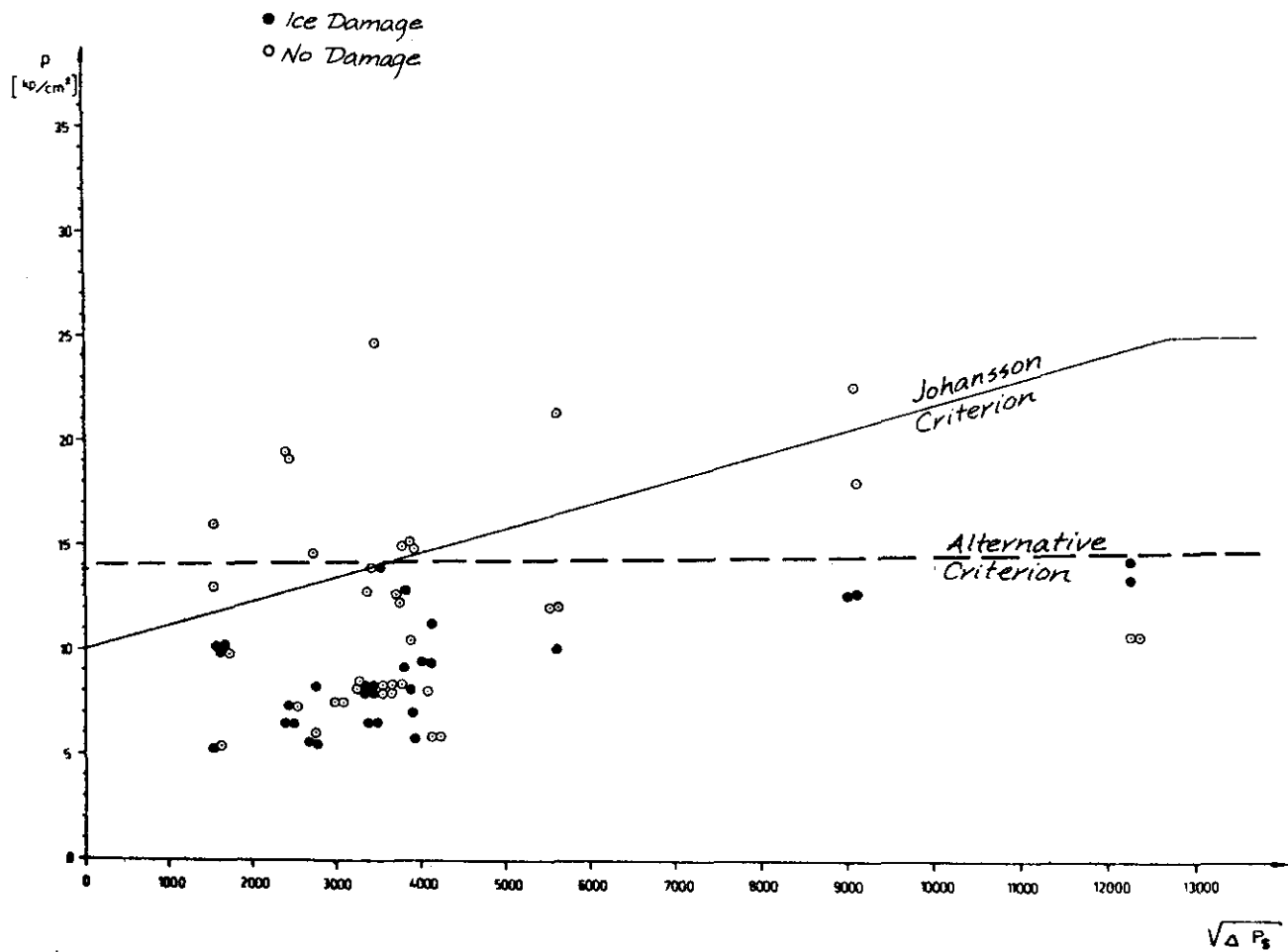

Figure 7.3. Example of Damage Analysis Conducted by Johansson from Ref. [B-16]

TABLE 7.2
SUMMARY OF DIFFERENCES AMONG ICE STRENGTHENING CRITERIA

	FACTORS USED TO DETERMINE DESIGN LOAD				DISTRIBUTION OF LOAD		STRUCTURAL RESPONSE	
	GEOGRAPHY & SEASON	SHIP SIZE & POWER	ICE PROPERTIES	HULL GEOMETRY	VERTICAL OR FOR FRAMES	HORIZONTAL OR FOR PLATING	FOR FRAMES	FOR PLATING
CASPPR	Yes, tables & maps published	No, min. size & power for var. I.C.	No	No, ? thru different areas or ship	800 mm @ mid-span for all classes	Continuous between web frames or bulkheads	Simple, elastic-plastic analysis formation of 3 hinges	Same, no correction for limited height
Johansson	No, but intended for Baltic Sea	Yes	No	No	800 mm @ mid-span for all classes	Continuous between web frames or bulkheads	Simple, elastic-plastic analysis formation of 3 hinges	Simple elastic-plastic analysis corrected for limited vertical dist. of load
Finnish-Swedish	Yes, via published notices	Yes	No	No	800 mm @ mid-span for all classes	Continuous between web frames or bulkheads	Simple, elastic-plastic analysis formation of 3 hinges	Same, no correction for limited height
ABS, Lloyds, etc. Based on Finnish-Swedish	No	Yes	No	No	800 mm @ mid-span for all classes	Continuous between Web Frames or Bulkheads	Simple, elastic-plastic analysis formation of 3 hinges	Same, no correction for limited height
USSR Register of Shipping Rules for Classification	No	f(ship length)	Not in rules, but apparently used in derivation	Yes	Pressure applied to full-span between stringers	Line load	?	?
US Coast Guard (Icebreakers)	Yes, based on operational requirements defined at time of design	Not codified Yes	Yes, not a variable but rationale is applied	No	Continuous over full-height between decks	Continuous over full length between bulkheads	Prelim-simple elastic analysis, Final-comparison of many methods	Prelim-simple elastic analysis, Final-comparison of many methods
DNV Icebreaker Arctic Icebreaker	No	Yes	No	No	Continuous over full-height between decks ?for limiting conditions	Continuous over full length between bulkheads ?for limiting conditions	? for limiting conditions	? for limiting conditions
NYK	No	Yes	No	No	Continuous over full-weight decks, ?for limiting conditions	Continuous over full-length between bulkheads ?for limiting conditions	? for limiting conditions	? for limiting conditions

8. PROPOSED RATIONAL BASIS FOR SELECTING ICE STRENGTHENING CRITERIA

8.1 Materials

No significant departure from the current state-of-the-art is required to properly address the requirements for materials for ships in ice covered waters. The following suggested criteria are based on those already in use by classification societies for low-temperature materials for ships carrying liquified gases in bulk.

- Establish an Environmental Service Temperature based on specific Arctic or Antarctic region and season of proposed operation.
- Apply the Environmental Service Temperatures to hull steels from 5 ft below the lowest waterline up, and throughout the deck for all steels exposed to the air.
- Base Service Temperature for Interior Service on heat transfer calculations.

The toughness criteria of ABS Section 24.55 [C-13] and USCG Marine Engineering Regulations Subchapter F are to be applied at a test temperature of 10°F (5°C) below (colder than) the service temperatures defined above.

8.2 Reliability

The absence of definitive descriptions of the loads and comprehensive response synthesis tools have been pointed out. There is a technique which allows these shortcomings to be recognized while preserving sufficient rigor to make at least general inferences about a structure's reliability. This technique is to attempt to evaluate individually and specifically all design factors involved. It involves the use of load factors, material property factors, limit response factors, failure mode factors, etc. [E-8, E-14].

There is not enough information to address the fatigue aspect of structural reliability. Both the cyclic nature of the ice loading and the fatigue properties of the particular steels suitable for ice strengthened ships need to be determined. The fact that fatigue and lifetime cycles are not included in these proposed criteria does not indicate that this aspect should remain undefined.

In the following paragraphs, an approach is presented which establishes a framework within which the individual design factors are defined. As a point of departure, specific numerical values are proposed for the design factors. It is recognized, even recommended, that the values assigned to these design factors be reviewed, researched, and revised.

8.3 Loads

The link between the environment and a ship's structure, in the case of conventional ship design, is the sea's surface--the waves. A single wave has four main parameters, height, length, direction, and frequency or period, not all of which are truly independent. The sea's surface, in general, requires a directional spectrum of distribution of wave heights by probability and direction. Although these factors are known and understood, the tools to apply this knowledge are still being developed. There has been, therefore, a great deal of reliance on analysis of the effect of a single wave. Conventional approaches usually use a wave length equal to the ship's length and a wave height defined by one of several relationships to wave length ($H_w = 0.6L_w^{0.6}$, $1.1 \sqrt{L_w}$, or $L_w/20$); and examine the static structural response in those terms. It was from this rather idealized approach that greater understanding developed.

In the case of ships in ice where, incidently, there are no waves, the loads imposed by the ice are every bit as stochastic in nature as wave loads. Since there are insufficient data to describe the ice itself in any probabilistic terms, let alone the impacts, the focus should be on an idealized form of interaction between the ship and ice.

It has been shown that to be relevant in terms of the analytical methods available, the description of the interaction must include the following:

- Intensity of the Load
- Vertical Extent of the Load
- Longitudinal Extent of the Load
- Spatial Dependence of the Intensity
- Time History of the Load.

8.3.1 Load Intensity

The two categories of factors which determine the intensity of ice loading are:

- a) The physical properties of the ice (particularly crushing strength), including triaxial effects and strain-rate effects; and
- b) the nature of the interaction between the hull and the ice.

It is clear that these two categories are not truly independent since the triaxial and strain-rate effects are implemented by conditions stemming from the interaction.

Since uniaxial crushing strength has been measured extensively and its dependence on temperature and salinity are fairly well known, the recommended point of departure for describing the load intensity is the uniaxial strength. This referenced crushing strength, σ_c , is therefore a function of: the kind of ice -- fresh or salt; the age of salt water ice -- first-year or multi-year; and the ambient air temperature (for simplicity broken into two categories -- "mid-winter" and "warm"). The following range of values is suggested:

TABLE 8.1 UNIAXIAL CRUSHING STRENGTH

TYPE OF ICE	TEMPERATURE	
	"MIDWINTER"	"WARM"
Fresh	400 psi	270 psi
MY	300 psi	240 psi
FY	250 psi	200 psi

Triaxial or confined strength is not well enough understood to be treated definitively, but clearly the extent of ice in contact with the hull is a factor. For now the "triaxial factor", f_T , is defined and assumed to be a function of ice thickness. Another possible mechanism which may bring triaxial strength into play is the rate of load application. At present this effect will be combined with other dynamic effects.

$f_T(t)$ is assumed to be on the order of 1 to 2 to 3 and to increase with thickness, approaching some maximum value asymptotically. A proposed $f_T(t)$ curve is shown in Figure 8.1.

Strain-rate effects at the high strain rates of interest are not all known, but as pointed out previously, there is some evidence that the effective crushing strength at appropriate strain rates may be higher by several times than the crushing strength in the nominal brittle range of strain rates.

The approach used in the mathematical model of hull-ice interaction discussed previously, does not reflect the dependencies on the interaction described above. Thus, there is no method available to adequately define or even evaluate this factor at the present time.

A strain-rate factor, f_P , which is truly a function of the details of the interaction but at the present state-of-knowledge a constant value on the order of 1.2 is recommended.

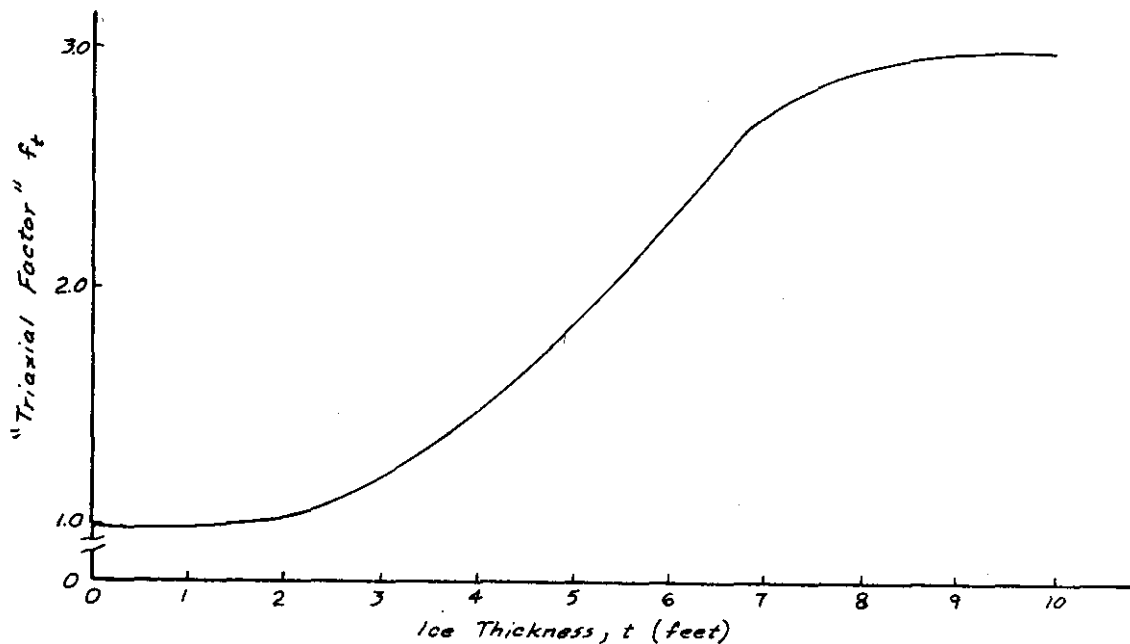

Figure 8.1 Proposed Triaxial Strength Factor

The load intensity becomes:

$$P = [\sigma_c(T, S) \cdot f_T(t) \cdot f_r] \quad (8.1)$$

where

T = temperature

S = season

σ_c = from Table 8.1

f_t = triaxial factor - from Figure 8.1

f_r = strain rate factor, 1.2

8.3.2 Extent of Load

The maximum vertical extent of the load, to a first, crude approximation is approximately equal to the ice thickness. The question of defining and being cognizant of the appropriate ice thickness to use must be addressed next.

Level, unbroken ice of uniform thickness rarely occurs in situations of interest. Irregular ice features inevitably pose the limiting conditions for ships. This is unquestionably so in the case of ship resistance and is reasonably assumed to be the case for structural loading. The main ice features of interest, defined previously, are:

- Pressure ridges, where the degree of consolidation in addition to total thickness is necessary to describe ridges.
- Iceberg and fragments, which are generally very thick and hard.

It is suggested that an effective level ice thickness, t_e , be defined which is the level ice thickness times a pressure ridge factor, f_{pr} , or iceberg or fragment factor, f_{ib} . These factors will be applied in a mutually exclusive sense to reflect that the effects of ridges and icebergs are not cumulative.

$$t_e = [t \cdot f_{pr}] \quad (8.2)$$

or

$$t_e = [t \cdot f_{ib}]$$

t_e is proposed to be used as the vertical extent of the load in subsequent analysis or synthesis.

As an initial value, f_{pr} is proposed to be 2.5 for first-year and 5 for multi-year ice. f_{ib} is proposed to be 5.0.

The horizontal extent of the load is more difficult to describe and it seems to be less significant in terms of strengthening required. In view of this, it is proposed that the horizontal extent of the load always be considered greater than one frame space. Concentration effects will be combined as described below.

8.3.3 Spacial and Temporal Variations

On the basis of general observations, we know that a typical ice load may be applied very rapidly and moves relative to a ship's hull. This motion is shown in Figure 8.2, taken from Ref [B-22]. These data from the POLAR STAR trials of 1976 clearly illustrate that the magnitude of ice loading varies with both time and location on the ship. Furthermore, the irregular shape of broken ice certainly does not truly result in the idealized uniform pressure used thus far to describe the load. At present, there is no way to describe these factors in general terms. The thickness dependence of the ice load intensity suggested in Section 8.1 represents the maximum or peak of the intensity distribution. Thus, refinements to incorporate the distribution will tend to make the criteria less stringent.

8.4 Response Criteria

Response criteria will be recommended only in the most general terms. The principal thrust of this effort was directed towards load criteria. Response criteria were introduced for completeness and in order to put the load criteria in perspective.

8.4.1 Plating Response

In keeping with the requirements that an analytical method be accurate and realistically represent the real world phenomena, the analysis of the plating of Jones [E-14] is recommended.

$$P_i = \frac{8 \sigma_y h W}{S^2} \quad W \leq h \quad (8.3)$$

where

P_i = pressure which will cause a permanent set	} in consistent units
W = permanent set	
h = plate thickness	
σ_y = yield strength	
S = frame spacing	

It is recognized that this approach has not been used by any of the regulatory/classification bodies in specifying plate thickness. It has been shown, however, that plating design standards have frequently been over specified relative to the frame and supporting structure design criteria. The plating should be given full credit for being able to carry the load calculated as recommended above. Deformation in itself does not constitute a failure of the plating's function. Limiting the deformation to the thickness of the plating is a reasonably conservative criterion.

Putting Equation (8-3) into the form suggested by this reasoning and incorporating the recommended allowable deformation, and adopting consistent notation:

$$t = S \frac{P}{8 \sigma_y} \quad (8.4)$$

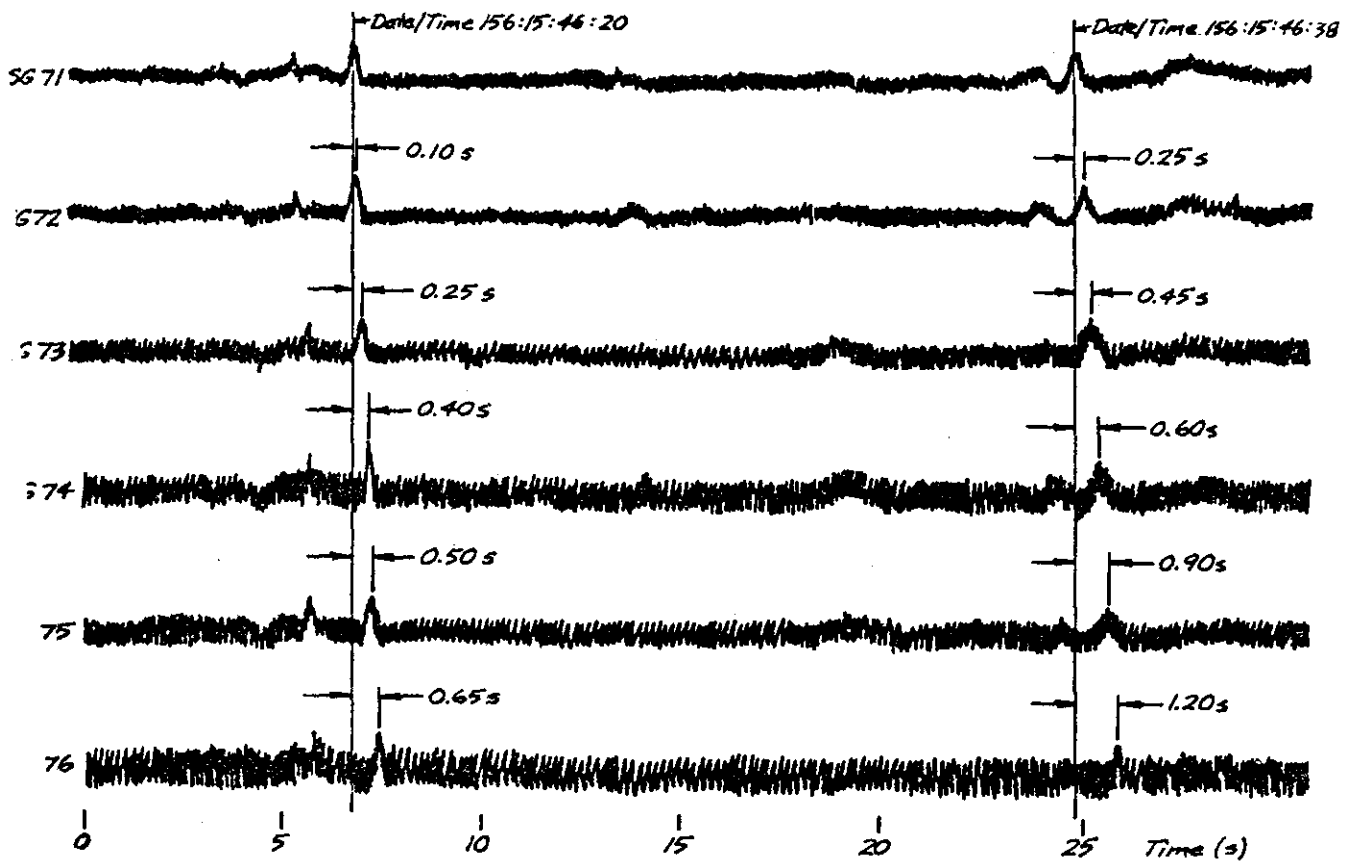

rain gage data (Cant Frames 70 to 75) showing ice movement along the hull.

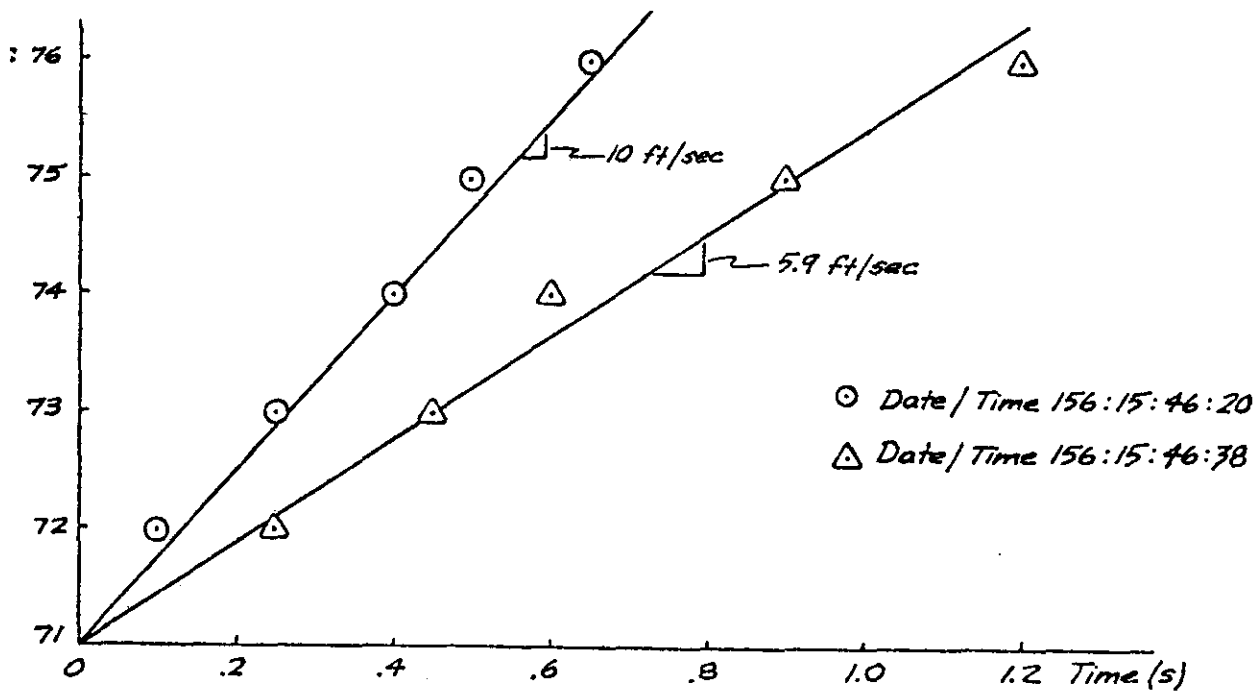

Graph of ice movement vs time gives speed of ice moving along hull.

Figure 8.2 Polar Star Hull (Strain Gage) Response, 1976

where t = plate thickness
 s = frame spacing
 P = design load intensity from Equation (8.3)
 σ_y = yield stress of plating material

Finite-element methods may also be used for the plating response analysis. Properly done, these solutions are more precise than other methods. The finite-element approach, to be consistent, must however allow for the same deformation recommended above. The relatively greater costs of finite element analysis make it more practical for a final design or verification than early preliminary designs.

8.4.2 Frame Response

Two factors tend to make the prediction of the framing response to loads more difficult than predicting the plating's response. These are:

- a) The susceptibility of framing systems to instability and consequent failure at low loads. Instability can result from either lack of attention to design details, (i.e., insufficient brackets) or from frame failure due to the production facility's failure to comply with the structural design details, (i.e. poor workmanship).
- b) The large number of possible collapse mechanisms.

In view of these factors, the shortcomings of Johansson's approach became acceptable. Therefore, the 3-hinge plastic analysis relationship derived by Johansson for the generalized distribution of the load is recommended. The mid-span location of a load of height t_e is proposed, where t_e is to be determined, along with the ice load, p , in accordance with the load criteria above. In consistent units, Johansson's Equation (8.2) becomes

$$\text{Required Section Modulus} = \frac{p \cdot t_e \cdot s (2l - t_e)}{16\sigma_y} \quad (8.5)$$

where p = ice load (design pressure) from Equation (8.1)
 t_e = height of ice load (effective thickness) from Equation (8.2)
 s = frame spacing
 l = frame span, corrected if appropriate for end brackets and haunches
 σ_y = yield stress of the material

The need for further analytical work on the structural response to ice loads is particularly acute in the area of the supporting structure. The method recommended above should only be used until a complete limit analysis has been conducted.

8.5 Summary of Proposed Approach

The proposed approach is as follows:

- First : Determine the ship operating area by season (month) from the owner's requirements. Then determine the environmental (ice) data from Appendix A.
- Second : With the season and location determine the uniaxial crushing strength from Table 8.1.
- Third : With the level ice thickness from Step 1, determine f_T from Figure 8.1.
- Fourth : Calculate the design load intensity using Equation (8.1).
- Fifth : Using $f_{pr} = 2.5$ or 5.0 for first and multi-year ice respectively and $f_{ib} = 5.0$, determine the effective ice thickness from Equation (8.2).
- Sixth : The required shell thickness is calculated according to Equation (8.4).
- Seventh : The required frame section modulus is calculated according to Equation (8.5).

9. RECOMMENDATIONS - NEEDED RESEARCH AND DEVELOPMENT

The recommendations take the form of an R&D program directed at the overall objective of developing and improving ice strengthening criteria. The need for several particular projects was identified in the preceding sections. The breakdown proposed follows the SSC's long term goals:

- Reliability Criteria
- Load Criteria
- Response Criteria

No R&D is recommended for the materials and fabrication areas. The work required in these fields seems to be either straightforward engineering applications of the state-of-the-art, or research to lower the cost of providing the required properties in shipbuilding steels.

Although the need for greater definition of ice conditions was clearly demonstrated in Section 3, no purely environmental projects are included in the recommended program. Rather, it is recommended that the Ship Structure Committee encourage the U.S. Coast Guard and other agencies to expand the current programs for collecting ice data. A particularly efficient approach would be to incorporate a very broad integrated environmental program with the full-scale test program. To a certain degree, this is planned, although the scope of any program is always limited by the available budget.

9.1 R&D Program Summary

Five project areas are recommended which address the objectives as shown in Table 9.1.

TABLE 9.1 R&D PROGRAMS TO IMPROVE ICE STRENGTHENING CRITERIA BREAKDOWN BY OBJECTIVES

Project Areas	Objectives	Reliability Criteria	Load Criteria	Response Criteria
Full-Scale Tests		X	X	X
Refine Rational Approach (Section 8)		X	X	
Response Criteria/Factors				X
Ice Interactions			X	
Analytic Model			X	

9.2 Full-Scale Tests

The entire problem of selecting ice strengthening criteria is severely complicated by the scarcity of pertinent data. Although the Canadian Coast Guard, Ship Safety Branch, has an R&D program which includes instrumentation of a Canadian icebreaker, the total amount of data is inadequate to:

- 1) Support any valid generalization of ice loads on a ship's hull;
- 2) Convincingly validate any analytical models of hull-ice interaction;
- 3) Provide any insight into the cyclic nature of ice loads with special attention to fatigue problems.

The U.S. Coast Guard's POLAR Class icebreakers are the most powerful in the free world and operate extensively in the Arctic and Antarctic. An ongoing research program, cooperative with MARAD and industry, is focused on the other aspects of icebreaker performance and environmental observation. This program provides an ideal basis for incorporating a structural research program.

The problems of instrumenting an icebreaker's hull and interpreting the results are considerable, but with proper design and planning, this may be accomplished on any one, or all, of three levels:

- 1) The least cost, simplest approach is to apply scratch strain gages. These are simple, reliable, and proven for shipboard application through SSC programs. This approach will provide the level of stress in the members strain gaged from which some general inferences about the adequacy of the design may be made. It will also provide important data about the cyclic nature of the ice loads. This method will not allow determination of the actual loads on the hull.

The first year's program, including experimental design, procurement, installation, analysis, and reporting could be accomplished for \$25,000. Subsequent years' data could be collected and analyzed, and the report updated for about \$10,000 per year, assuming the same gages remain in place.

- 2) It is possible to so stiffen a section of the hull around an unstiffened area that the hull plating acts as a diaphragm in response to ice loads. With accompanying instrumentation and analysis, it would be possible to infer the average ice load acting on that "diaphragm." This system and the required instrumentation and data handling techniques have been developed to the point where it can be planned in detail with confidence.

The structural work is such that a long lead time and coordination with the ships drydocking or repair schedule would be necessary. A project, "piggybacked" on the existing R&D projects for the POLAR Class, is estimated to cost \$250,000 for the experimental design, installation, and the first year's data acquisition, analysis, and report. Subsequent years' data acquisition would cost about \$100,000 per year.

- 3) It is possible to install pressure transducers through the hull of an icebreaker. The data handling required would be similar to that required for level (2) above. Although the techniques are developmental, this is the approach selected by the Canadian Coast Guard. A large array of these transducers would allow the actual pressure distribution to be determined.

This approach also requires a long lead time for planning and coordination. It is estimated that the first year's effort would cost \$500,000.

9.3 Refine the Rational Approach (Section 8)

Section 8 proposes a basis for the rational selection of ice strengthening criteria. The basis may be more accurately thought of as a framework; an approach and certain specific concepts have been identified. However, no comprehensive set of rules or criteria have been developed. To work towards that end, additional work along this line is required. Three particular tasks are necessary:

- TASK 1 - Refine the load factors. Assemble all pertinent data and generate an exchange of opinions of researchers in the field. Strive for a consensus; however, keep the basic approach intact.
- TASK 2 - Compare the ice strengthening plates and scantlings resulting from this approach with existing criteria, generally along the lines that the existing criteria were compared among themselves. Analyze and resolve inconsistencies.
- TASK 3 - Rationalize the ice data into a limited number of ice classes. The framework proposed offers methods to develop equivalent ice loads for varying ice conditions. An equivalent ice thickness concept may emerge.

The three tasks will contribute to an overall revision of the basis or framework, each task having some feedback to the other tasks. The framework itself will be modified as these efforts are pursued.

If performed together, under the direction of the same principal investigator, the three tasks would entail about one man-year of effort and cost \$60,000. This approach is recommended, since each task would cost \$25,000 to \$30,000 if done independently.

9.4 Incorporate Response Criteria into the Approach Proposed in Section 8

The approach of Section 8 focuses on load criteria. Response criteria considerations must be incorporated into the overall approach.

- 1) Develop Response Factors - Apply analytic techniques systematically to a limited but large number of configurations. Finite-element methods may be appropriate, if valid simplifying assumptions can be made. Plastic frame failure mode analysis should allow insight from which generalizations can be made at a lower level of effort than would be required for finite element analysis.

It is proposed that a man-year effort, under the direction of a structural analyst and coordinated with load criteria research, would produce significant results. It is estimated that this would cost \$60,000.

- 2) Conduct Analysis of Hull Ice Damage, Correlating Where Possible With Ice Conditions and Ship Operating Parameters. A thorough analytical analysis, applying the techniques of McDermott [E-24] and others, will be required to develop the most effective methodology. Once the method is established, the investigating team would personally investigate ice damage incidents and apply the techniques. The Canadian Coast Guard R&D program includes damage analysis.

The first year's effort, including the development of techniques and their application, would cost \$50,000. In follow-on years, the team could investigate ice damage incidents as cases occur, or on a level-of-effort basis. A budget figure of \$25,000 per year is suggested.

9.5 Ice Interaction

The goal would be to define the governing ice structure interaction process in sufficient detail and accuracy to be pertinent to ship ice strengthening criteria.

The effects of confinement and rate of load application in generating higher triaxial crushing strengths must be determined. As a starting point, proprietary research results should be purchased and studied. The detail of these tests and the range of variables are both of limited application to ship-ice interactions. The entire phenomenon involved should be studied analytically, in laboratory experiments, and in very large, essentially full-scale, field tests. The confinement effect should be related to some easily measured ice property, such as the bore-hole jack test results [A-9], and/or easily defined parameters of the interaction, such as a component of impact speed. The strain-rate dependence of ice crushing strength should be investigated experimentally and in laboratory and full-scale tests. Finally, the distribution of the ice pressure should be determined. Some of the experiments outlined above may provide data which describe the load distribution. The Canadian Coast Guard, Ship Safety Branch, has a research program which will address these requirements to a considerable extent.

The initial effort should be an in-depth analysis of the solid mechanics phenomena involved in hull-ice interaction. The output of this would be an analytical basis for a mathematical model. A \$100,000 effort will be required to focus on both triaxial and strain-rate effects. The second phase is seen as a rather extensive experimental laboratory program to expand and validate the analytical model. The program would cost approximately \$300,000.

Because scale effects may prove to be very significant, a field test program with very large samples will be required to definitively validate the analytical model. Depending on the hardware required, this program would cost between \$500,000 and \$1,500,000. Proprietary results of an oil company's large-scale field tests would serve as important input for planning these field tests.

9.6 Generalize the Analytic Model of Ship-Ice Interaction

The mathematical model used in Section 8 can be improved to provide much more insight into the dynamics of ship-ice interactions. The model should be modified to provide for the effects of:

- 1) Confinement from which high triaxial crushing strengths are developed in the ice;
- 2) High strain rates which may effect the crushing strength of the ice;
- 3) A non-constant load distribution.

The model should be revised to provide an output load in terms directly applicable to the selection of ice strengthening criteria. Finally, the model must be validated with full-scale data. The Canadian Coast Guard's research program includes the incorporation of pressure distribution into the analytical model of ship-ice interaction.

A \$50,000 effort should be sufficient to refine the model including computer time. A second follow-on effort is recommended to incorporate the results of the R&D programs defined in Section 9.5. The validation effort will also include "tuning" the analytical model with the full-scale test data and should cost about \$25,000.

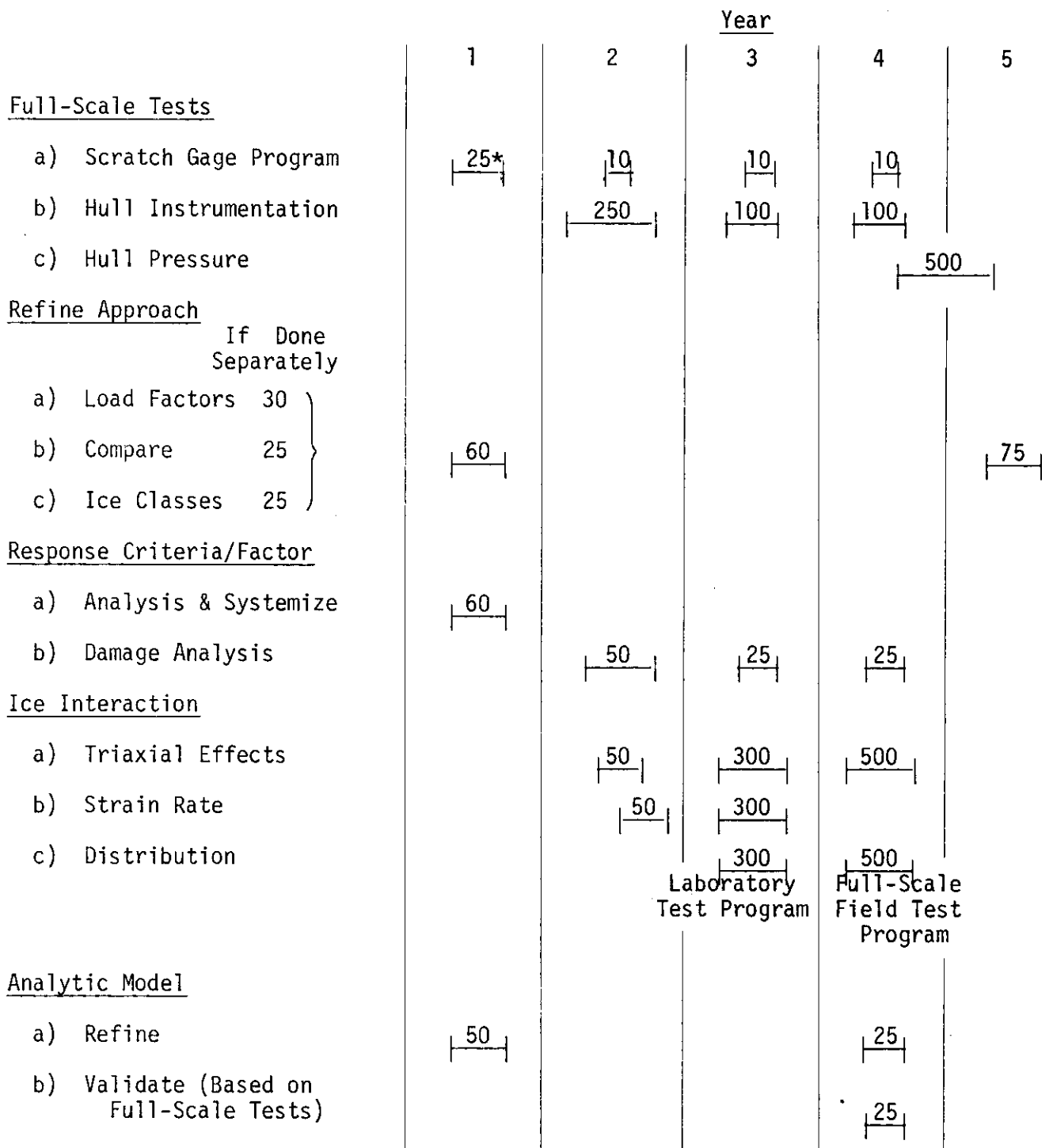

* Thousands of Dollars

Figure 9.1 Recommended Schedule for R&D Program

10. BIBLIOGRAPHY

A review of pertinent U.S. and foreign literature was conducted to assess the current state-of-the-art in the selection of ice strengthening criteria for vessels. The following bibliography presents the results of this search and the references cited in the text of this report. To facilitate use of this bibliography, the references have been categorized as follows:

- Environmental
- Ice Loads on a Hull
- Classification Society Rules
- Design Criteria
- Design and Analysis Techniques
- Materials and Fabrication
- Operating Histories of Existing Ships

If a reference contained information relevant to more than one category, it is listed in both sections.

Environmental Conditions

- A-1 Ahlmas, K. and G. Wendler, "Sea Ice Conditions in the Chukchi, Beaufort, East Siberian, and Northern Bering Seas During March of 1973 and 1974 as Seen from NOAA 2/3," *Proceedings of the Third International Conference on Port and Ocean Engineering Under Arctic Conditions*, University of Alaska, Institute of Marine Science, Fairbanks, Alaska, Vol. I, 1975, pp. 83-104.
- A-2 Bilello, M. A., "Ice Thickness Observations in the North American Arctic and Subarctic for 1958-59 [to Current Year]," U.S. Army, Cold Regions Research and Engineering Laboratory, Hanover, NH, Special Report 43 (produced annually).
- A-3 Borgert, N., "Ice Conditions Along the Alaskan Coast During Breakup," *Proceedings of the Third International Conference on Port and Ocean Engineering Under Arctic Conditions*, University of Alaska, Institute of Marine Science, Fairbanks, Alaska, Vol. I, 1975, pp. 555-556.
- A-4 Bradford, J. D., "Sea-Ice Pressure Generation and Its Effect on Navigation in the Gulf of St. Lawrence Area," *Inst. Nav. J.*, Vol. 24, No. 4, 1971, pp. 512-520.
- A-5 Brower, W. A., Jr., H. W. Searby, H. F. Diaz, A. S. Prechtel, and J. L. Wise, "Climatic Atlas of the Outer Continental Shelf Waters and Coastal Regions of Alaska; Volume III: Chukchi-Beaufort Sea," Arctic Environmental Information Data Center, University of Alaska, Anchorage, Alaska; National Climatic Center, Environmental Service, Asheville, NC; and National Oceanic and Atmospheric Administration, for U.S. Department of the Interior, Bureau of Land Management, AEIDC Publication B-77, 1977.
- A-6 Butyagin, I. P., *Strength of Ice and Ice Cover - Nature Research on the Rivers of Siberia*, Nauka Publishing House, Siberian Department, Novosibirsk, 1966 (CRREL Translation TL284, Hanover, NH).
- A-7 Dayton, R. B., "Polar Icebreaker Preliminary Structural Design and Special Studies," Consultec, Incorporated Report No. 006, for U.S. Coast Guard, Office of Engineering, Icebreaker Design Project, Washington, D.C., August 1968.
- A-8 Deily, F. H., "Aerial Reconnaissance and Subsea Profiling of Sea Ice in the Bering Sea," *Proceedings of the Fifth International Conference on Port and Ocean Engineering Under Arctic Conditions*, The University of Trondheim, The Norwegian Institute of Technology, Trondheim, Norway, Vol. 1, 1979, pp. 207-220.
- A-9 Dunbar, M., "The Monthly and Extreme Limits of Ice in the Bering Sea," Paper presented at the Eleventh Pacific Science Congress, Tokyo, Japan, 1966.
- A-10 Environment Canada, "Ice Data, 1965 to 1973," Ottawa, Canada.

- A-11 Environment Canada, "Ice Thickness Data for Canadian Stations," Ottawa, Canada, 1972-73, 1973-74, 1974-75, 1975-76, 1976-77, 1977-78.
- A-12 Environment Canada, Ice Climatology Branch, Ottawa, Canada, personal communication, 1980.
- A-13 Estrada, H. and S. R. Ward, "Forces Exerted by Ice on Ships, *Journal of Ship Research*, December 1968, pp. 302-312.
- A-14 Fenco Consultants Ltd. and F. F. Slaney and Company, Limited, "An Arctic Atlas: Background Information for Developing Marine Oilspill Countermeasures," for Environmental Emergency Branch, Environmental Impact Control Directorate, Environmental Protection Service, Calgary, Alberta, Canada, EPS-9-EC-78-1, August 1978.
- A-15 Gold, L. W., "Use of Ice Covers for Transportation," *Canadian Geotechnical Journal*, Vol. 8, No. 2, May 1971, pp. 170-181.
- A-16 Hibler, W. D. III and S. F. Ackley, "A Sea Ice Terrain Model and Its Application to Surface Vehicle Trafficability," Cold Regions Research and Engineering Laboratory, Technical Note, Hanover, NH, July 1973.
- A-17 Hibler, W. D. III and S. J. Mock, "Classification of Sea Ice Ridging and Surface Roughness in the Arctic Basin," Compiled by S. Santeford and J. L. Smith for National Academy of Science, Washington, D.C., 1974, pp. 244-254.
- A-18 Hibler, W. D. III and W. F. Weeks, and S. J. Mock, "Statistical Aspects of Sea-Ice Ridge Distribution," *Journal of Geophysical Research*, Vol. 77, No. 30, 1977, pp. 5954-5970.
- A-19 Kivisine, H. R. and S. H. Iyer, "Insitu Tests for Ice Strength Measurements," *Ocean Engineering*, Vol. 3, 1976.
- A-20 Kniskern, F. E. and G. J. Potocsky, "Frost Degree Day, Related Ice Thickness Curves, and Harbor Freezep and Breakup Dates for Selected Arctic Stations," U.S. Naval Oceanographic Office, Washington, D.C., Technical Report No. TR-60, July 1965 (reprinted April 1970).
- A-21 Kovacs, A., "On the Structure of Pressured Sea Ice," U.S. Army, Cold Regions Research and Engineering Laboratory, Hanover, NH, September 1970.
- A-22 Lowry, R. T. and P. Wadhams, "On the Statistical Distribution of Pressure Ridges in Sea Ice," *Journal of Geophysical Research*, Vol. 84, No. C5, May 20, 1979.
- A-23 Lyon, W., "Under Surface Profiles of Sea Ice Observed by Submarine," Paper presented at the Eleventh Pacific Science Congress, Tokyo, Japan, 1966.
- A-24 Major, R. A., D. M. Berenger, and C. J. R. Lawrie, "A Model to Predict Hull-Ice Impact Loads on the St. Lawrence River," Paper presented at the Ice Tech Symposium, Society of Naval Architects and Marine Engineers, New York, NY, April 1973.
- A-25 Michel, B., *Ice Mechanics*, Les Presses De L'Universite Laval, Quebec, 1978.

- A-26 Mock, S. J., A. D. Hartwell, and W. D. Hibler, "Spatial Aspects of Pressure Ridge Statistics," *Journal of Geophysical Research*, Vol. 77, No. 30, 1972, pp. 5945-5953.
- A-27 National Oceanic and Atmospheric Administration, "Summary of Great Lakes Weather and Ice Conditions [1964-1978]," Great Lakes Environmental Research Laboratory, NOAA, Technical Memorandum, Ann Arbor, MI, published annually.
- A-28 Nevel, D. E., "A Semi-Infinite Plate on an Elastic Foundation," U.S. Army, Cold Regions Research and Engineering Laboratory, Report No. 136, Hanover, NH, March 1965.
- A-29 Northern Associates (Holdings) Ltd., "Arctic Resources By Sea," for Ministry of Transport, Ottawa, Canada, July 1973.
- A-30 Peyton, H. R. and C. E. Behlke, "A Thickness Survey of Pack Ice Along the Northwest Alaska Coast," Arctic Environmental Engineering Laboratory, University of Alaska, Fairbanks, 1969.
- A-31 Potocsky, G. J., "Alaskan Area 15- and 30-Day Ice Forecasting Guide," Naval Oceanographic Office, Washington, D.C., February 1975.
- A-32 Rondy, D. R., "Great Lakes Ice Atlas," Department of Commerce, National Oceanic and Atmospheric Administration, Detroit, MI, April 1969.
- A-33 Richardson, F. A. and B. M. Burns, "Ice Thickness Climatology for Canadian Stations," for Environment Canada, Ottawa, Canada, 1975.
- A-34 Secretariat of the World Meteorological Organization, "World Meteorological Organization Sea-Ice Nomenclature," Geneva, Switzerland, WMO/OMM/BMO No. 259 TP.145, 1970.
- A-35 Selkregg, Lidia L. (ed.), "Alaska Regional Profiles: Volume II - Arctic Region," Arctic Environmental Information and Data Center, University of Alaska, Anchorage, for the State of Alaska, Office of the Governor and the Joint Federal-State Land Use Planning Commission for Alaska, 1975.
- A-36 Shapiro, L. H., "A Preliminary Study of Ridging in Landfast Ice at Barrow, Alaska Using Radar Data," *Proceedings of the Third International Conference on Port and Ocean Engineering Under Arctic Conditions*, University of Alaska, Institute of Marine Science, Fairbanks, Alaska, Vol. I, 1975, pp. 417-426.
- A-37 Shapiro, L. and J. J. Burns, "Satellite Observations of Sea Ice Movement in the Bering Strait Region," in *Climate of the Arctic*, Gunter Weller and Sue Ann Bowling, eds., University of Alaska, Fairbanks, Alaska, 1975, pp. 379-386.
- A-38 U.S. Department of the Navy, "Birds Eye," Naval Oceanographic Office, Oceanographic Prediction Division, Informal Reports, Washington, D.C., 1965-1970.
- A-39 U.S. Department of the Navy, "Report of the Arctic Ice Observing and Forecasting Program," Naval Oceanographic Office Special Publication, Washington, D.C., published annually.
- A-40 U.S. Department of the Navy, "Oceanographic Atlas of the Polar Seas, Part I, Antarctic," Naval Oceanographic Office, H. O. Pub. No. 705, Washington, D.C., 1957 (reprinted 1970).

- A-41 Voelker, R. P., F. W. DeBord, and K. E. Dane, "Operational Assessment of Commercial Icebreaking Ships in Western Alaskan Waters Based on POLAR Class Trafficability Test Data," Volumes I and II, for U.S. Department of Commerce, Maritime Administration Report MA-RD-940-79071, Washington, D.C., July 20, 1979.
- A-42 Voelker, R. P., F. W. DeBord, J. J. Nelka, and J. W. Jacobi, "Assessment of Ice Conditions in the South Bering Sea Based on April 1980 USCG POLAR Class Trafficability Test Data," Volumes I and II, for U.S. Department of Commerce, Maritime Administration, Washington, D.C., June 6, 1980.
- A-43 Weeks, W. F. and A. Kovacs, "On Pressure Ridges," U.S. Army, Cold Regions Research and Engineering Laboratory, Hanover, NH, January 1970.
- A-44 Wittman, W. I. and J. J. Schule, Jr., "Comments on the Mass Budget of Arctic Pack Ice; Informal Report," Naval Oceanographic Office, Washington, D.C., March 1967.
- A-45 Wright, B., J. Hnatiuk, and A. Kovacs, "Multi-Year Pressure Ridges in the Canadian Beaufort Sea," *Proceedings of the Fifth International Conference on Port and Ocean Engineering Under Arctic Conditions*, The University of Trondheim, The Norwegian Institute of Technology, Trondheim, Norway, Vol. I, 1979, pp. 107-126.

- B-12 Fisher, L. and R. R. Addonizio, "Investigation of the Strengthening of Large Tankers for Operation in the Arctic Region," SS MANHATTAN Arctic Marine Project, Report No. 337, U.S. Maritime Administration, Washington, D.C., 1979. (Original report prepared by Gibbs and Cox, Inc. for Esso International, Inc., August 1969.)
- B-13 Frederking, R., "Preliminary Results of Plane Strain Compression Tests on Columnar - Grained Ice," *Proceedings of the IAHR Symposium on Ice and Its Action on Hydraulic Structures*, Leningrad, September 1972, pp. 23-27.
- B-14 Gold, L. W., "Engineering Properties of Fresh-Water Ice," National Research Council, Ottawa, Canada, 1976.
- B-15 Gold, L. W. and A. S. Krausz, "Investigation of the Mechanical Properties of St. Lawrence River Ice," National Research Council, Report Paper No. 470, Ottawa, Canada, May 1971. (Reprinted from *Canadian Geotech. Journal*, Vol. 8 No. 2, p. 163, May 1971.)
- B-16 Johansson, B. M., "On the Ice-Strengthening of Ship Hulls," *International Shipbuilding Progress; Shipbuilding and Marine Engineering Monthly*, Vol. 14, No. 154, June 1967.
- B-17 Kheisin, D. E., "Determination and Appraisal of the Structural Strength of Ships Navigating in Ice, by Recalculating from the Prototype." Translated from *Sudostroenie*, 27, No. 1, January 1961.
- B-18 Kheisin, D. E., "Determination of External Loads Which Act on a Ship Hull During Ice Compression." Translated from *Problemy Arktiki i Antarktiki*, Vol. 7, 1961, pp. 25-31.
- B-19 Kheisin, D. E., "Determination of Contact Forces Acting in the Zone of Impact of Ships With Ice." Translated by G. J. Dvorak from *Problemy Arktiki i Antarktiki*, Vol. 22, 1966, pp. 96-102.
- B-20 Kheisin, D. E. and Iu. N. Popov, "Ice Navigation Qualities of Ships," *Trudy AANII*, Vol. 309, 1972. Translation available from Defense Documentation Center, Alexandria, VA.
- B-21 Kotras, T. V., P. P. Kosterich, and R. P. Voelker, "Ice Impact Forces on the Bow of a Great Lakes Bulk Carrier," ARCTEC, Incorporated, Report No. 160C-2, for U.S. Department of Commerce, Maritime Administration, Washington, D.C., March 1977.
- B-22 Lecourt, E. J. and J. A. McIntosh, "POLAR STAR 1976 Ice Trials," U.S. Coast Guard Report DOT-CG-4339A, Washington, D.C., October 1977.
- B-23 Levine, G. H., R. P. Voelker, and P. B. Mentz, "Advances in the Development of Commerical Ice-Transiting Ships," *Transactions*, Society of Naval Architects and Marine Engineers, New York, N.Y., Vol. 82, 1974.

- B-24 Lloyd's Register of Shipping, "Large Polar Icebreaker for the U.S. Coast Guard," R&TA Report No. 5047, London, England, March 1967.
- B-25 Lloyd's Register of Shipping, "Cargo Tank Reinforcement of SS MANHATTAN for Polar Ice Service," SS MANHATTAN Arctic Marine Project, Report No. 201, U.S. Maritime Administration, Washington, D.C., 1979. (Original report prepared for Esso International, Inc.)
- B-26 Major, R. A., D. M. Berenger, and C. L. R. Lawrie, "A Model to Predict Hull-Ice Impact Loads in the St. Lawrence River," Paper presented at the Ice Tech Symposium, Society of Naval Architects and Marine Engineers, New York, N.Y., April 1975.
- B-27 Maklakov, N. T., "Icebreaking Cargo Vessels for Arctic Waters," *Sudostroenie*, 27, Vol. 1, 1967, p. 4, British Ship Research Association, Translation No. 1870, Tyne and Wear, England.
- B-28 MARCOM Corporation, "Determination of Forces Generated During Impact Between a Ship and a Large Mass of Ice," for Esso International Inc., New York, N.Y., not dated.
- B-29 Melberg, L. C., J. W. Lewis, R. Y. Edwards, Jr., R. G. Taylor, and R. P. Voelker, "The Design of Polar Icebreakers," Society of Naval Architects and Marine Engineers, Spring Meeting, New York, N.Y., April 1970.
- B-30 Michel, B. and N. Toussaint, "Mechanism and Theory of Indentation of Ice Plates," Laval University, Quebec, 1976.
- B-31 Milano, V. R., "Ship Resistance to Continuous Motion in Ice," *Transactions*, Society of Naval Architects and Marine Engineers, New York, N.Y., Vol. 81, 1973.
- B-32 Mookhoek, A. D. and W. J. Bielstein, "Problems Associated with the Design of an Arctic Marine Transportation System," *Preprints of the Third Annual Offshore Technology Conference*, Volume II, Houston, Texas, 1971, pp. 123-146.
- B-33 Newport News Shipbuilding and Dry Dock Company, "SS MANHATTAN Shell Loading Analysis," SS MANHATTAN Arctic Marine Project, Report No. 232, U.S. Maritime Administration, Washington, D.C., 1979. (Original report prepared by Hull Technical Department, Newport News Shipbuilding and Dry Dock Company for Humble Oil and Refining Company, January 1971.)
- B-34 Neill, C. R. and H. Schultz, "Measurements of Ice Forces and Strengths, Spring 1972," Research Council of Alberta, Report No. REH/73/1, Canada, January 1973.
- B-35 Nielsen, Richard Jr., "Ice Compression of Ships," SS MANHATTAN Arctic Marine Project, Report No. 338, U.S. Maritime Administration, Washington, D.C., 1979. (Original report prepared by MARCOM Corporation for Humble Oil and Refining Company, 3 January 1969.)

- B-36 Noble, P. G., W. K. Tam, B. Menon, and I. M. Bayly, "Ice Forces and Accelerations on a POLAR Class Icebreaker," *Proceedings of the Fifth International Conference on Port and Ocean Engineering Under Arctic Conditions*, The University of Trondheim, The Norwegian Institute of Technology, Trondheim, Norway, Vol. II, August 1979, pp. 1003-1022.
- B-37 Nogid, L. M., "Impact of Ships with Ice," *Transactions of the Leningrad Shipbuilding Institute*, No. 26, 1959, p. 123, British Ship Research Association, Translation No. 1867, Tyne and Wear, England.
- B-38 Popov, Yu. N., O. V. Faddeev, D. E. Kheisin, and A. A. Yakovlev, "Strength of Ships Navigating in Ice." Translated from *Sudostroenie*, 1968.
- B-39 Prewitt Associates, "Data Obtained from Scratch Strain Gages Installed on SS MANHATTAN Trip, 28 March - 18 June 1970," SS MANHATTAN Arctic Marine Project, Report No. 233, U.S. Maritime Administration, Washington, D.C., 1979. (Original report prepared for Humble Oil and Refining Company.)
- B-40 Shimanskij, J. A., "Conditional Standards of Ice Qualities of a Ship," *Transactions of the Arctic Institute*, 1938. Translated by Marine Computer Applications Corporation, 1969.
- B-41 Sodhi, D. S., L. Button, R. Boetes, and M. Arockiasamy, "Estimation of Ice Forces on the Hull of M.V. ARCTIC EXPLORER By Strain Gage Measurements," *Proceedings of the Fourth International Conference on Port and Ocean Engineering Under Arctic Conditions*, Memorial University of Newfoundland, St. Johns, Newfoundland, Canada, Vol. I, 1977, pp. 475-484.
- B-42 Sun Shipbuilding and Dry Dock Company, "Sun Conversion C-3, SS MANHATTAN Salient Features List," SS MANHATTAN Arctic Marine Project, Report No. 200, U.S. Maritime Administration, Washington, D.C. 1979. (Original report prepared for Humble Oil and Refining Company and Esso International, Inc., 25 June 1969.)
- B-43 Tarshis, M. K., "Ice Loads Acting on Ships." Translated from *Rechnoi Transport*, Vol. 16, No. 12, 1957, p. 19.
- B-44 Technology Incorporated, "Analysis and Presentation of Prewitt Scratch Gage Data as Recorded on the SS MANHATTAN," SS MANHATTAN Arctic Marine Project, Report No. 234, Washington, D.C., 1979. (Original report prepared for Prewitt Associates, 16 July 1970.)
- B-45 Vuorio, J., K. Riska, and D. Varsta, "Long Term Measurements of Ice Pressures and Ice-Induced Stresses on the Icebreaker, SISU, in Winter 1978," Winter Navigation Research Board, Report No. 28, April 1979.
- B-46 Waterman, R. L., "Structural Tests of Coast Guard Icebreaker WESTWIND (WAGB 281)," David Taylor Model Basin, Structural Mechanics Laboratory, Research and Development Report No. 2134, Washington, D.C., January 1966.
- B-47 White, R. M., "Dynamically Developed Force at the Bow of an Icebreaker," dissertation presented to the Massachusetts Institute of Technology, Cambridge, MA, September 1965, in partial fulfillment of the requirements for the degree of Doctor of Science.

CLASSIFICATION SOCIETY RULES

- C-1 Achtarides, T. A., "Plastic Design of Plate Panels for Ice Strengthening and Slamming," Society of Naval Architects and Marine Engineers, New England Section, Quincy, MA, September 1972.
- C-2 Aldwinckle, D. S., "Direct Calculation Methods in Ship Structural Design," Lloyd's Register of Shipping, for International Shipbuilding Symposium, London, England, May 1978.
- C-3 Board of Navigation, "Regulations for Classification of Ships into Various Ice Classes," Finland, 9 April 1965. Translated by the Department of the Navy.
- C-4 Board of Navigation, "Finnish-Swedish Ice Class Rules - Rules for Assigning Ships Separate Ice - Due Classes," Finland, 6 April 1971.
- C-5 Johansson, B. M., "On the Ice-Strengthening of Ship Hulls," *International Shipbuilding Progress; Shipbuilding and Marine Engineering Monthly*, Vol. 14, No. 154, June 1967.
- C-6 Kaldjian, M., "Ice Strengthening of Great Lakes Ore Carriers - A Computer-Aided Analysis," University of Michigan, College of Engineering, Department of Naval Architecture and Marine Engineering, Report No. 138, Ann Arbor, MI, January 1973.
- C-7 Lloyd's Register of Shipping, "Large Polar Icebreaker for the U.S. Coast Guard," R & TA Report No. 5054, London, England, not dated.
- C-8 Major, R. A., D. M. Berenger, and C. L. R. Lawrie, "A Model to Predict Hull-Ice Impact Loads in the St. Lawrence River," Paper presented at the Ice Tech Symposium, Society of Naval Architects and Marine Engineers, New York, N.Y., April 1975.
- C-9 Mäkinen, P., "Winter Navigation in the Bothnian Bay and the Iceworthiness of Merchant Vessels," Translated by M. Kaldjian, University of Michigan, College of Engineering, Department of Naval Architecture and Marine Engineering, Report No. 132, Ann Arbor, MI, September 1972.
- C-10 Nowacki, H., "Great Lakes Winter Navigation - Technical and Economic Analyses; Vol. III: Parametric Series," University of Michigan, College of Engineering, Department of Naval Architecture and Marine Engineering, Report No. 153, Ann Arbor, MI, May 1974.

- C-11 "Arctic Water Pollution Prevention Act," *Canadian Gazette*, Part II, Vol. 106, No. 20, 10 October 1972.
- C-12 "Finnish-Swedish Ice Class Rules 1971."
- C-13 *Rules for the Building and Classing of Steel Vessels*, American Bureau of Shipping, 1979.
- C-14 *Rules and Regulations for the Construction and Classification of Steel Ships*, Lloyd's Register of Shipping, 1972.
- C-15 *Rules and Regulations for the Construction and Classification of Steel Ships*, Bureau Veritas, 1972.
- C-16 *Rules and Regulations for the Construction and Classification of Ships*, Nippon Kaiji Kyokai, 1979.
- C-17 *Rules for the Construction and Classification of Steel Ships*, Det Norske Veritas, 1977.
- C-18 *Rules for the Construction and Classification of Ships*, Registro Italiano Navale.
- C-19 *Rules for the Classification and Construction of Seagoing Steel Ships*, Germanischer Lloyd, 1973.
- C-20 *Rules for the Classification and Construction of Seagoing Ships*, USSR Register of Shipping, 1978.
- C-21 *Rules for the Construction of Seagoing Ships*, Register of Shipping of the Peoples Republic of China, 1978.

DESIGN CRITERIA

- D-1 Achtarides, T. A., "Plastic Design of Plate Panels for Ice Strengthening and Slamming," Society of Naval Architects and Marine Engineers, New England Section, Quincy, MA, September 1972.
- D-2 Barber, B. H., L. M. Baez, and G. J. North, "Structural Considerations in the Design of POLAR Class Coast Guard Icebreakers," Paper presented at the Ship Structure Symposium, Society of Naval Architects and Marine Engineers, New York, N. Y., October 1975.
- D-3 Crighton, L. J., "Icebreakers - Their Design and Construction," Lloyd's Register of Shipping, London, England, not dated.
- D-4 Dayton, R. B., "Polar Icebreaking Preliminary Structural Design and Special Studies," Consultec, Incorporated Report No. 006, for U.S. Coast Guard, Office of Engineering, Icebreaker Design Project, Washington, D.C., August 1968.
- D-5 Fallon, H. E. Jr., "USCG POLAR Class Icebreaker Design Parameters and Features in Advancement of Icebreaker Design," *Proceedings of the Third International Conference on Port and Ocean Engineering Under Arctic Conditions*, University of Alaska, Institute of Marine Science, Fairbanks, Alaska, Vol. I, 1975, pp. 571-580.
- D-6 Fey, E., W. Pilkey and P. Estes, "Structural Analysis of Polar Icebreaker Bows," IIT Research Institute, Project J6127 for U.S. Coast Guard, Icebreaker Design Project, Washington, D.C., November 1968.
- D-7 German, J. G., "Design and Construction of Icebreakers," *Transactions*, Society of Naval Architects and Marine Engineers, New York, N.Y., Vol. 67, 1959.
- D-8 Gibbs and Cox, Inc., "Icebreaker (AGB) Report on Preliminary Design for Bureau of Ships," for Bureau of Ships, Department of the Navy, Washington, D.C., June 1951.
- D-9 Gouljaeff, N., "Modern Icebreakers," *The Shipbuilder and Marine Engineering Builder*, Vol. 67, June 1960, pp. 368-371.
- D-10 Johansson, B. M., "On the Ice-Strengthening of Ship Hulls," *International Shipbuilding Progress; Shipbuilding and Marine Engineering Monthly*, Vol. 14, No. 154, June 1967.
- D-11 Kheisin, D. E., "Determination and Appraisal of the Structural Strength of Ships Navigating in Ice, by Recalculating from the Prototype." Translated from *Sudostroenie*, 27, No. 1, January 1961.

- D-12 Kheisin, D. E. and Iu. N. Popov, "Ice Navigation Qualities of Ships," *Trudy AANII*, Vol.309, 1973. Translation available from Defense Documentation Center, Alexandria, VA.
- D-13 Laskey, N. V., "Designing a Bulk Carrier for the Canadian Arctic," *The Motor Ship*, March 1976, pp. 71-76.
- D-14 Lloyd's Register of Shipping, "Large Polar Icebreaker for U.S. Coast Guard," R & TA Report No. 5047, London, England, March 1967.
- D-15 Lloyd's Register of Shipping, "Large Polar Icebreaker for the U.S. Coast Guard," R & TA Report No. 5048, London, England, April 1967.
- D-16 Lloyd's Register of Shipping, "Large Polar Icebreaker for the U.S. Coast Guard," R & TA Report No. 5051, London, England, not dated.
- D-17 Lloyd's Register of Shipping, "Large Polar Icebreaker for the U.S. Coast Guard," R & TA Report No. 5054, London, England, not dated.
- D-18 Maklakov, N. T., "Icebreaking Cargo Vessels for Arctic Waters," *Sudostroenie*, 27, No. 1, 1967, p. 4. British Ship Research Association, Translation No. 1870, Tyne and Wear, England.
- D-19 Melberg, L. C., J. W. Lewis, R. Y. Edwards, E. G. Taylor, and R. P. Voelker, "The Design of Polar Icebreakers," Society of Naval Architects and Marine Engineers, Spring Meeting, New York, N.Y., April 1970.
- D-20 Popov, Yu. N., O. V. Faddeev, D. E. Kheisin, and A. A. Yakovlev, "Strength of Ships Navigating in Ice." Translated from *Sudostroenie*, 1978.
- D-21 Shimanskij, J. A., "Conditional Standards of Ice Qualities of a Ship," *Transactions of the Arctic Institute*, 1938. Translated by Marine Computer Applications Corporation, 1969.
- D-22 U.S. Coast Guard, "Specifications for 400-Foot Icebreaker for the United States Coast Guard," Naval Engineering, Washington, D.C., February 1971.
- D-23 U.S. Coast Guard, "Specifications for 140-Foot Harbor Tug (WYTM)," Naval Engineering, Washington, D.C., October 1975.
- D-24 U.S. Coast Guard, "Preliminary Design Report for a Great Lakes and Eastern Arctic Icebreaker," Naval Engineering, Washington, D.C., October 1978.

DESIGN AND ANALYSIS TECHNIQUES

- E-1 Achtarides, T. A., "Plastic Design of Plate Panels for Ice Strengthening and Slamming," Society of Naval Architects and Marine Engineers, New England Section, Quincy, MA, September 1972.
- E-2 Aldwinckle, D. S., "Direct Calculation Methods in Ship Structural Design," Lloyd's Register of Shipping, for International Shipbuilding Symposium, London, England, May 1978.
- E-3 Band, E. G. U., "Analysis of Ship Data to Predict Long-Term Trends of Hull Bending Moments," American Bureau of Shipping, New York, NY, November 1966.
- E-4 Barber, B. H., L. M. Baez, and G. J. North, "Structural Considerations in the Design of POLAR Class Coast Guard Icebreakers," Paper presented at the Ship Structure Symposium, Society of Naval Architects and Marine Engineers, New York, NY, October 1975.
- E-5 Chazal, E. A., J. E. Goldberg, J. J. Nachtsheim, R. W. Rumke, and A. B. Stavouy, "Third Decade of Research Under the Ship Structure Symposium," Paper presented at the Ship Structure Symposium, Society of Naval Architects and Marine Engineers, New York, NY, October 1975.
- E-6 Clarkson, J., "A New Approach to the Design of Plates to Withstand Lateral Pressures," *Transactions*, Institution of Naval Architects, Vol. 98, 1956.
- E-7 Dayton, R. B., "Polar Icebreaker Preliminary Structural Design and Special Studies," Consultec, Incorporated Report No. 006, for U.S. Coast Guard, Office of Engineering, Icebreaker Design Project, Washington, D.C., August 1968.
- E-8 Evans, J. H., ed., "Ship Structural Design Concepts," Ship Structure Committee Report SR 200, Washington, D.C., June 1974.
- E-9 Fey, E., W. Pilkey, and P. Estes, "Structural Analysis of Polar Icebreaker Bows," IIT Research Institute, Project J6127 for U.S. Coast Guard, Icebreaker Design Project, Washington, D.C., November 1968.
- E-10 Genalis, P., "Three Dimensional Stresses in Icebreaker Primary Structures," Massachusetts Institute of Technology, Department of Naval Architecture and Marine Engineering, Cambridge, MA, for U.S. Coast Guard, Office of Engineering, Icebreaker Design Project, Washington, D.C., May 1967.
- E-11 Haaland, A., "Damages to Important Structural Parts of the Hull," Det Norske Veritas, Publication No. 61, Oslo, Norway, January 1968.

- E-12 Hughes, O. F., F. Mistree, and V. Zanic, "A Practical Method for the Rational Design of Ship Structures," *Journal of Ship Research*, Vol. 24, No. 2, New York, June 1980.
- E-13 Johansson, B. M., "On the Ice-Strengthening of Ship Hulls," *International Shipbuilding Progress; Shipbuilding and Marine Engineering Monthly*, Vol. 14, No. 154, June 1967.
- E-14 Jones, N., "Plastic Behavior of Ship Structures," *Transactions, Society of Naval Architects and Marine Engineers*, New York, NY, Vol. 84, 1976.
- E-15 Kheisin, D. E., "Determination and Appraisal of the Structural Strength of Ships Navigating in Ice, by Recalculating from the Prototype." Translated from *Sudostroenie*, 27, No. 1, January 1961.
- E-16 Kheisin, D. E. and Yu. N. Popov, "Ice Navigation Qualities of Ships," *Trudy AANII*, Vol. 309, 1973. Translation available from Defense Documentation Center, Alexandria, VA.
- E-17 Kiesling, E. W., "Structural Analysis Including Thermal Effects for Icebreakers," Southwest Research Institute, Houston, TX, for the U.S. Coast Guard, Icebreaker Branch, Washington, D.C., 30 June 1967.
- E-18 Kirrkamm, D. and E. C. Bumb, "Ein Beitrag Zur Entwicklung eins Festigkeitsnachweises für Schiffe auf der Grundlage der Methode der finiten Elemente," Finite Element Congress, Baden-Baden, Germany, 6-7 November 1972 (in German).
- E-19 Lloyd's Register of Shipping, "Large Polar Icebreaker for the U.S. Coast Guard," R & TA Report No. 5048, London, England, April 1967.
- E-20 Lloyd's Register of Shipping, "Large Polar Icebreaker for the U.S. Coast Guard," R & TA Report No. 5051, London, England, not dated.
- E-21 Lloyd's Register of Shipping, "Large Polar Icebreaker for the U.S. Coast Guard," R & TA Report No. 5054, London, England, not dated.
- E-22 Lloyd's Register of Shipping, "Cargo Tank Reinforcement of SS MANHATTAN for Polar Ice Service," SS MANHATTAN Arctic Marine Project, Report No. 201, U.S. Maritime Administration, Washington, D.C., 1979. (Original report prepared for Esso International, Inc.)
- E-23 Lloyd's Register of Shipping, "Representative Finite Element Model of Side-shell Grillage and a Plane Transverse Frame Subject to Ice Loads Appropriate to Arctic Class 7," Lloyd's Register Industrial Services, London, England, 1976.
- E-24 McDermott, J. F., R. G. Kilne, E. L. Jones, N. M. Maniar, and W. P. Chiang, "Tanker Structural Analysis for Minor Collisions," *Transactions, Society of Naval Architects and Marine Engineers*, New York, NY, November 1974.

- E-25 Popov, Yu. N., O. V. Faddeev, D. E. Kheisin, and A. A. Yakovlev, "Strength of Ships Navigating in Ice." Translated from *Sudostroenie*, 1968.
- E-26 Raskin, Yu. N., "Method of Determining the Stresses in Decks and Transverse Bulkheads Caused by Ice Loads," Translated from *Sudostroenie*, 28, No. 7, 1962.
- E-27 Roark, R. J. and W. C. Young, *Formulas for Stress and Strain*, 5th ed., McGraw Hill, 1975.
- E-28 Shimanskiji, J. A., "Conditional Standards of Ice Qualities of a Ship," *Transactions of the Arctic Institute*, 1938. Translated by Marine Computer Applications Corporation, 1969.
- E-29 Sun Shipbuilding and Dry Dock Company, "Sun Conversion C-3, SS MANHATTAN Salient Features List," SS MANHATTAN Arctic Marine Project, Report No. 200, U.S. Maritime Administration, Washington, D.C., 1979. (Original report prepared for Humble Oil Company and Esso International, Inc., 25 June 1969.)
- E-30 Taylor, K. V. and J. Lundgren, "Full-Scale Static and Dynamic Measurements on MV NIHON," Reprinted from the *Transactions of RINA*, Vol. 118, 1976, pp. 49-72.

MATERIALS AND FABRICATION

- F-1 Barber, B. H., L. M. Baez, and G. J. North, "Structural Considerations in the Design of the POLAR Class Coast Guard Icebreakers," Paper presented at the Ship Structure Symposium, Society of Naval Architects and Marine Engineers, New York, NY, October 1975.
- F-2 Fallon, H. E., Jr., "USCG POLAR Class Icebreaker Design Parameters and Features in Advancement of Icebreaker Design," *Proceedings of the Third International Conference on Port and Ocean Engineering Under Arctic Conditions*, University of Alaska, Institute of Marine Science, Fairbanks, Alaska, Vol. I, 1975, pp. 571-580.
- F-3 Francis, P. H., T. S. Cook, and A. Nagy, "Fracture Behavior Characterization of Ship Steels and Weldments," NTIS, U.S. Department of Commerce, Washington, D.C., October 1968.
- F-4 Hahn, G. T., R. G. Hoagland, P. N. Mincer, A. R. Rosenfield, and M. Sarrate, "Crack Propagation and Arrest in Ship and Other Steels," Ship Structure Committee, NTIS No. AD731674, U.S. Department of Commerce, Washington, D.C., August 1970.
- F-5 Hawthorne, J. R. and F. J. Loss, "Fracture Toughness Characterization of Shipbuilding Steels," Ship Structure Committee, NTIS No. AD785034, U.S. Department of Commerce, Washington, D.C., July 1974.
- F-6 James, L. A., "An Investigation of the Fatigue and Fracture Properties of Selected Hull Plate Samples from the Coast Guard Cutter STATEN ISLAND," for U.S. Coast Guard, Washington, D.C., 14 August 1969.
- F-7 Kaldjian, M. J. and K. N. Huang, "Great Lakes Winter Navigation - Technical and Economic Analyses; Vol. V: Ice Strengthening of Ship Hulls Using Steel, Ferrocement, or Reinforced Concrete," University of Michigan, College of Engineering, Department of Naval Architecture and Marine Engineering, Report No. 155, Ann Arbor, MI, June 1974.
- F-8 Munse, W. H., J. P. Cannon, and J. F. Kiefner, "Effect of Repeated Loads on the Low Temperature Fracture Behavior of Notched and Welded Plates," Ship Structure Committee, NTIS NO. AD676722, U.S. Department of Commerce, Washington, D.C., October 1968.
- F-9 Nippon Steel Corporation, "Steel Plates for Low Temperatures," Tokyo, Japan, April 1976.
- F-10 Nordell, W. R., "Construction of the POLAR STAR, A Shipyard View," Society of Naval Architects and Marine Engineers, Philadelphia Section, January 1975.

- F-11 Society of Naval Architects and Marine Engineers, "Guide for High Strength and Special Application Steels for Marine Use," SNAME Panel HS-6, Technical and Research Bulletin 2-20, New York, NY, May 1976.
- F-12 U.S. Coast Guard, "Specification for 400-Foot Icebreaker for the United States Coast Guard," Naval Engineering, Washington, D.C., February 1971.
- F-13 U.S. Coast Guard, "Specifications for 140-Foot Harbor Tug (WYTM)," Naval Engineering, Washington, D.C., October 1975.

OPERATING HISTORIES OF EXISTING SHIPS

- G-1 Baez, L. M., U.S. Coast Guard, Naval Engineering, personal communication.
- G-2 Barber, B. H., L. M. Baez, and G. J. North, "Structural Considerations in the Design of POLAR Class Coast Guard Icebreakers," Paper presented at the Ship Structure Symposium, Society of Naval Architects and Marine Engineers, New York, NY, October 1975.
- G-3 Crighton, L. J., "Icebreakers - Their Design and Construction," Lloyd's Register of Shipping, London, England, not dated.
- G-4 Dayton, R. B., "Polar Icebreaker Preliminary Structural Design and Special Studies," Consultec, Incorporated Report No. 006, for U.S. Coast Guard, Office of Engineering, Icebreaker Design Project, Washington, D.C., August 1968.
- G-5 Fey, E., W. Pilkey, and P. Estes, "Structural Analysis of Polar Icebreaker Bows," IIT Research Institute, Project J6127, for the U.S. Coast Guard, Icebreaker Design Project, Washington, D.C., November 1968.
- G-6 German, J. G., "Design and Construction of Icebreakers," *Transactions*, Society of Naval Architects and Marine Engineers, New York, NY, Vol. 67, 1959.
- G-7 Gibbs and Cox, Inc., "Icebreaker (AGB) Report on Preliminary Design for Bureau of Ships," for Bureau of Ships, Department of the Navy, Washington, D.C., June 1951.
- G-8 Gouljaeff, N., "Modern Icebreakers," *The Shipbuilder and Marine Engineering Builder*, Vol. 67, June 1960, pp. 368-371.
- G-9 Johansson, B. M., "On the Ice-Strengthening of Ship Hulls," *International Shipbuilding Progress; Shipbuilding and Marine Engineering Monthly*, Vol. 14, No. 154, June 1967.
- G-10 Laskey, N. V., "Designing a Bulk Carrier for the Canadian Arctic," *The Motor Ship*, March 1976, pp. 71-76.
- G-11 Laskey, N. V., "Design of Steering Gears, Rudders, Rudder Stocks and Propeller Protection for Canadian Arctic Class Vessels," Paper presented at the New England Section, Society of Naval Architects and Marine Engineers, April 12, 1979.
- G-12 Makinen, P., "Winter Navigation in the Bothnian Bay and Iceworthiness of Merchant Vessels." Translated by M. Kaldjian, University of Michigan, College of Engineering, Department of Naval Architecture and Marine Engineering, Report No. 132, Ann Arbor, MI, September 1972.
- G-13 Marine Media Management, Ltd., "An Ice Breaking Products Tanker Designed for Safe, Year-Round Navigation in the Finnish Archipelago," June 1974.

- G-14 Newport News Shipbuilding and Dry Dock Company, "SS MANHATTAN Shell Loading Analysis," SS MANHATTAN Arctic Marine Project, Report No. 232, U.S. Maritime Administration, Washington, D.C., 1979. (Original report prepared by Hull Technical Department, Newport News Shipbuilding and Dry Dock Company for Humble Oil and Refining Company, January 1971.)
- G-15 Popov, Yu. N., O. V. Faddeev, D. E. Kheisin, and A. A. Yakovlev, "Strength of Ships Navigating in Ice." Translated from *Sudostroenie*, 1968.
- G-16 Prewitt Associates, "Data Obtained from Scratch Strain Gages Installed on SS MANHATTAN Trip, 28 March - 18 June 1970," SS MANHATTAN Arctic Marine Project, Report No. 233, U.S. Maritime Administration, Washington, D.C., 1979. (Original report prepared for Humble Oil and Refining Company.)
- G-17 Stiglitz, J. and G. Schmieding, "The Diesel-Electric Polar Icebreaker 'MOSKVA'," *Ship and Port*, No. 11, 1960, pp. 3-15.
- G-18 Sun Shipbuilding and Dry Dock Company, "Survey of Damages - SS MANHATTAN, November 1969," SS MANHATTAN Arctic Marine Project, Report No. 220, U.S. Maritime Administration, Washington, D.C., 1979. (Original report dated November 1969.)
- G-19 Technology Incorporated, "Analysis and Presentation of Prewitt Scratch Gage Data as Recorded on the SS MANHATTAN," SS MANHATTAN Arctic Marine Project, Report No. 234, U.S. Maritime Administration, Washington, D.C., 1979. (Original report prepared for Prewitt Associates, 16 July 1970.)
- G-20 Vuorio, F., K. Riska, and D. Varsta, "Long Term Measurements of Ice Pressures and Ice Induced Stresses on the Icebreaker, SISU, in Winter 1978," Winter Navigation Research Board, Report No. 28, April 1979.
- G-21 Waterman, R. L., "Structural Tests of Coast Guard Icebreaker WESTWIND (WAGB 281)," David Taylor Model Basin, Structural Mechanics Laboratory, Research and Development Report No. 2134, Washington, D.C., January 1966.

APPENDIX

ICE TERMS ARRANGED IN ALPHABETICAL ORDER

- Aged ridge: *Ridge* which has undergone considerable weathering. These ridges are best described as undulations.
- Anchor ice: Submerged ice attached or anchored to the bottom, irrespective of the nature of its formation.
- Bare ice: Ice without snow cover.
- Belt: A large feature of *pack ice* arrangement; longer than it is wide; from 1 km to more than 100 km in width.
- Bergy bit: A large piece of floating *glacier ice*, generally showing less than 5 m above sea-level but more than 1 m and normally about 100-300 sq. m in area.
- Beset: Situation of a vessel surrounded by ice and unable to move.
- Big floe: (see *Floe*).
- Bight: An extensive crescent-shaped indentation in the *ice edge*, formed by either wind or current.
- Brash ice: Accumulations of *floating ice* made up of fragments not more than 2 m across, the wreckage of other forms of ice.
- Bummock: From the point of view of the submariner, a downward projection from the underside of the *ice canopy*; the counterpart of a *hummock*.
- Calving: The breaking away of a mass of ice from an *ice wall*, *ice front*, or *iceberg*.
- Close pack ice: *Pack ice* in which the *concentration* is 7/10 to 8/10 (6/8 to less than 7/8, composed of *floes* mostly in contact.
- Compacted ice edge: Close, clear-cut *ice edge* compacted by wind or current; usually on the windward side of an area of *pack ice*.
- Compacting: Pieces of *floating ice* are said to be compacting when they are subjected to a converging motion, which increases ice *concentration* and/or produces stresses which may result in ice deformation.
- Compact pack ice: *Pack ice* in which the *concentration* is 10/10 (8/8) and no water is visible.
- Concentration: The ratio in tenths of the sea surface actually covered by ice to the total area of sea surface, both ice-covered and *ice-free*, at a specific location or over a defined area.
- Concentration boundary: A line approximating the transition between two areas of *pack ice* with distinctly different *concentrations*.

Consolidated pack ice: *Pack ice* in which the *concentration* is 10/10 (8/8) and the *floes* are frozen together.

Consolidated ridge. A *ridge* in which the base has frozen together.

Crack: Any *fracture* which has not parted.

Dark nilas: *Nilas* which is under 5 cm in thickness and is very dark in color.

Deformed ice: A general term for ice which has been squeezed together and in places forced upwards (and downwards). Subdivisions are *rafted ice*, *ridged ice*, and *hummocked ice*.

Difficult area: A general qualitative expression to indicate, in a relative manner, that the severity of ice conditions prevailing in an area is such that navigation in it is difficult.

Diffuse ice edge: Poorly defined *ice edge* limiting an area of dispersed ice; usually on the leeward side of an area of *pack ice*.

Diverging: *Ice fields* or *floes* in an area are subjected to diverging or dispersive motion, thus reducing *ice concentration* and/or relieving stress in the ice.

Dried ice: *Sea ice* from the surface of which melt-water has disappeared after the formation of *cracks* and *thaw holes*. During the period of drying, the surface whitens.

Easy area: A general qualitative expression to indicate, in a relative manner, that ice conditions prevailing in an area are such that navigation in it is not difficult.

Fast ice: *Sea ice* which forms and remains fast along the coast, where it is attached to the shore, to an *ice wall*, to an *ice front*, between shoals or grounded *icebergs*. Vertical fluctuations may be observed during changes of sea-level. Fast ice may be formed *in situ* from sea water or by freezing of *pack ice* of any age to the shore, and it may extend a few metres or several hundred-kilometres from the coast. Fast ice may be more than one year old and may then be prefixed with the appropriate age category (*old*, *second-year*, or *multi-year*). If it is thicker than about 2 m above sea-level it is called an *ice shelf*.

Fast-ice boundary: The *ice boundary* at any given time between *fast ice* and *pack ice*.

Fast-ice edge: The demarcation at any given time between *fast ice* and *open water*.

Finger rafted ice: Type of *rafted ice* in which *floes* thrust "fingers" alternately over and under the other.

Finger rafting: Type of rafting whereby interlocking thrusts are formed, each floe thrusting "fingers" alternately over and under the other. Common in *nilas* and *grey ice*.

Firn: Old snow which has recrystallized into a dense material. Unlike snow, the particles are to some extent joined together; but, unlike ice, the air spaces in it still connect with each other.

First-year ice: *Sea ice* of not more than one winter's growth, developing from *young ice*; thickness 30 cm - 2 m. May be subdivided into *thin first-year ice* /white ice, *medium first-year ice*, and *thick first-year ice*.

Flaw: A narrow separation zone between *pack ice* and *fast ice*, where the pieces of ice are in chaotic state; it forms when *pack ice* shears under the effect of a strong wind or current along the *fast ice boundary*.

Flaw lead: A passage-way between *pack ice* and *fast ice* which is navigable by surface vessels.

Flaw polynya: A *polynya* between *pack ice* and *fast ice*.

Floating ice: Any form of ice found floating in water. The principal kinds of floating ice are *lake ice*, *river ice*, and *sea ice*, which form by the freezing of water at the surface, and *glacier ice* (*ice of land origin*) formed on land or in an *ice shelf*. The concept includes ice that is stranded or grounded.

Floe: Any relatively flat piece of *sea ice* 20 m or more across. Floes are subdivided according to horizontal extent as follows:

- GIANT: Over 10 km across.
- VAST: 2-10 km across.
- BIG: 500-2,000 m across.
- MEDIUM: 100-500 m across.
- SMALL: 20-100 m across.

Floeberg: A massive piece of *sea ice* composed of a *hummock*, or a group of *hummocks*, frozen together and separated from any ice surroundings. It may float up to 5 m above sea-level.

Flooded ice: *Sea ice* which has been flooded by melt-water or river water and is heavily loaded by water and wet snow.

Fracture: Any break or rupture through *very close pack ice*, *compact pack ice*, *consolidated pack ice*, *fast ice*, or a single *floe* resulting from deformation processes. Fractures may contain *brash ice* and/or be covered with *nilas* and/or *young ice*. Length may vary from a few meters to many kilometers.

Fracture zone: An area which has a great number of fractures.

Fracturing: Pressure process whereby ice is permanently deformed, and rupture occurs. Most commonly used to describe breaking across *very close pack ice*, *compact pack ice*, and *consolidated pack ice*.

Frazil ice: Fine spicules or plates of ice, suspended in water.

Friendly ice: From the point of view of the submariner, an *ice canopy* containing may large *skylights* or other features which permit a submarine to surface. There must be more than ten such features per 30 nautical miles (56 km) along the submarine's track.

Frost smoke: Fog-like clouds due to contact of cold air with relatively warm water, which can appear over openings in the ice, or leeward of the *ice edge*, and which may persist while ice is forming.

Giant floe: (see *Floe*).

Glacier: A mass of snow and ice continuously moving from higher to lower ground or, if afloat, continuously spreading. The principal forms of glacier are: inland ice sheets, *ice shelves*, *ice streams*, ice caps, ice piedmonts, cirque glaciers, and various types of mountain (valley) glaciers.

Glacier berg: An irregularly shaped *iceberg*.

Glacier ice: Ice in, or originating from, a *glacier*, whether on land or floating on the sea as *icebergs*, *bergy bits*, or *growlers*.

Glacier tongue: Projecting seaward extension of a *glacier*, usually afloat. In the Antarctic glacier tongues may extend over many tens of kilometers.

Grease ice: A later stage of freezing than *frazil ice* when the crystals have coagulated to form a soupy layer on the surface. Grease ice reflects little light, giving the sea a matt appearance.

Grey ice: *Young ice* 10-15 cm thick. Less elastic than *nilas* and breaks on swell. Usually rafts under pressure.

Grey-white ice: *Young ice* 15-30 cm thick. Under pressure more likely to ridge than to raft.

Grounded hummock: Hummocked *grounded ice* formation. There are single grounded *hummocks* and lines (or chains) of grounded *hummocks*.

Grounded ice: *Floating ice* which is aground in shoal water.

Growler: Smaller piece of ice than a *bergy bit* or *floeberg*, often transparent but appearing green or almost black in color, extending less than 1 m above the sea surface and normally occupying an area of about 20 sq. m.

Hostile ice: From the point of view of the submariner, an *ice canopy* containing no large *skylights*.

Hummock: A hillock of broken ice which has been forced upwards by pressure. May be fresh or weathered. The submerged volume of broken ice under the hummock, forced downwards by pressure, is termed a *hummock*.

Hummocked ice: *Sea ice* piled haphazardly one piece over another to form an uneven surface. When weathered, has the appearance of smooth hillocks.

Hummocking: The pressure process by which *sea ice* is forced into *hummocks*. When the floes rotate in the process it is termed screwing.

Iceberg: A massive piece of ice of greatly varying shape, more than 5 m above sea-level, which has broken away from a *glacier*, and which may be afloat or aground. Icebergs may be described as *tabular*, dome-shaped, sloping, pinnacled, weathered, or *glacier bergs*.

Iceberg tongue: A major accumulation of *icebergs* projecting from the coast, held in place by grounding and joined together by *fast ice*.

Ice blink: A whitish glare on low clouds above an accumulation of distant ice.

Ice-bound: A harbor, inlet, etc., is said to be ice-bound when navigation by ships is prevented on account of ice, except possibly with the assistance of an icebreaker.

Ice boundary: The demarcation at any given time between *fast ice* and *pack ice* or between areas of *pack ice* of different *concentrations*.

Ice breccia: Ice pieces of different age frozen together.

Ice cake: Any relatively flat piece of *sea ice* less than 20 m across.

Ice canopy: *Pack ice* from the point of view of the submariner.

Ice cover: The ratio of an area of ice of any concentration to the total area of sea surface within some large geographic local; this local may be global, hemispheric, or prescribed by a specific oceanographic entity such as Baffin Bay or the Barents Sea.

Ice edge: The demarcation at any given time between the open sea and *sea ice* of any kind, whether fast or drifting. It may be termed *compacted* or *diffuse*.

Ice field: Area of *pack ice* consisting of any size of *floes*, which is greater than 10 km across.

Icefoot: A narrow fringe of ice attached to the coast, unmoved by tides and remaining after the *fast ice* has moved away.

Ice-free: No *sea ice* present. There may be some *ice of land origin*.

Ice front: The vertical cliff forming the seaward face of an *ice shelf* or other floating *glacier* varying in height from 2-50 m or more above sea-level.

Ice island: A large piece of floating ice about 5 m above sea-level, which has broken away from an Arctic ice shelf, having a thickness of 30-50 m and an area of from a few thousand square meters to 500 sq. km or more, and usually characterized by a regularly undulating surface which gives it a ribbed appearance from the air.

Ice jam: An accumulation of broken *river ice* or *sea ice* caught in a narrow channel.

Ice keel: From the point of view of the submariner, a downward-projecting ridge on the underside of the *ice canopy*; the counterpart of a ridge. Ice keels may extend as much as 50 m below sea-level.

Ice limit: Climatological term referring to the extreme minimum or extreme maximum extent of the *ice edge* in any given month or period based on observations over a number of years. Term should be preceded by minimum or maximum.

Ice massif: A concentration of *sea ice* covering hundreds of square kilometers, which is found in the same region every summer.

Ice of land origin: Ice formed on land or in an *ice shelf*, found floating in water. The concept includes ice that is stranded or grounded.

Ice patch: An area of *pack ice* less than 10 km across.

Ice port: An embayment in an *ice front*, often of a temporary nature, where ships can moor alongside and unload directly onto the ice shelf.

Ice rind: A brittle shiny crust of ice formed on a quiet surface by direct freezing or from *grease ice*, usually in water of low salinity. Thickness to about 5 cm. Easily broken by wind or swell, commonly breaking in rectangular pieces.

Ice shelf: A floating ice sheet of considerable thickness showing 2-50 m or more above sea-level, attached to the coast. Usually of great horizontal extent and with a level or gently undulating surface. Nourished by annual snow accumulation and often also by the seaward extension of land *glaciers*. Limited areas may be aground. The seaward edge is termed an *ice front*.

Ice stream: Part of an inland ice sheet in which the ice flows more rapidly and not necessarily in the same direction as the surrounding ice. The margins are sometimes clearly marked by a change in direction of the surface slope but may be indistinct.

Ice under pressure: Ice in which deformation processes are actively occurring and hence a potential impediment or danger to shipping.

Ice wall: An ice cliff forming the seaward margin of a *glacier* which is not afloat. An ice wall is aground, the rock basement being at or below sea-level.

Lake ice: Ice formed on a lake, regardless of observed location.

Large fracture: More than 500 m wide.

Large ice field: An *ice field* over 20 km across.

Lead: Any *fracture* or passage-way through *sea ice* which is navigable by surface vessels.

Level ice: *Sea ice* which is unaffected by deformation.

Light nilas: *Nilas* which is more than 5 cm in thickness and rather lighter in color than *dark nilas*.

Mean ice edge: Average position of the *ice edge* in any given month or period based on observations over a number of years. Other terms which may be used are mean maximum ice edge and mean minimum ice edge.

Medium first-year ice: *First-year ice* 70-120 cm thick.

Medium floe: (see *Floe*).

Medium fracture: 200 to 500 m wide.

Medium ice field: An *ice field* 15-20 km across.

Multi-year ice: *Old ice* up to 3 m or more thick which has survived at least two summers' melt. *Hummocks* even smoother than in *second-year ice*, and the ice is almost salt-free. Color, where bare, is usually blue. Melt pattern consists of large interconnecting irregular *puddles* and a well-developed drainage system.

New ice: A general term for recently formed ice which includes *frazil ice*, *grease ice*, *slush*, and *shuga*. These types of ice are composed of ice crystals which are only weakly frozen together (if at all) and have a definite form only while they are afloat.

New ridge: *Ridge* newly formed with sharp peaks and slope of sides usually 40°. Fragments are visible from the air at low altitude.

Nilas: A thin elastic crust of ice, easily bending on waves and swell and under pressure, thrusting in a pattern of interlocking "fingers" (*finger rafting*). Has a matt surface and is up to 10 cm in thickness. May be subdivided into *dark nilas* and *light nilas*.

Nip: Ice is said to nip when it forcibly presses against a ship. A vessel so caught, though undamaged, is said to have been nipped.

Old ice: *Sea ice* which has survived at least one summer's melt. Most topographic features are smoother than on *first-year ice*. May be subdivided into *second-year ice* and *multi-year ice*.

Open pack ice: *Pack ice* in which the *ice concentration* is 4/10 to 6/10 (3/8 to less than 6/8) with many *leads* and *polynyas*, and the *floes* are generally not in contact with one another.

Open water: A large area of freely navigable water in which *sea ice* is present in *concentrations* less than 1/10 (1/8). When there is no sea ice present, the area should be termed *ice-free*, even though icebergs are present.

Pack ice: Term used in a wide sense to include any area of *sea ice*, other than *fast ice*, no matter what form it takes or how it is disposed.

Pancake ice: Predominantly circular pieces of ice from 30 cm - 3 m in diameter, and up to about 10 cm in thickness, with raised rims due to the pieces striking against one another. It may be formed on a slight swell from *grease ice*, *shuga* or *slush* or as a result of the breaking of *ice rind*, *nilas* or, under severe conditions of swell or waves, of *grey ice*. It also sometimes forms at some depth, at an interface between water bodies of different physical characteristics, from where it floats to the surface; its appearance may rapidly cover wide areas of water.

Polynya: Any non-linear shaped opening enclosed in ice. Polynyas may contain *brash ice* and/or be covered with *new ice*, *nilas* or *young ice*; submariners refer to these as *skylights*. Sometimes the polynya is limited on one side by the coast and is called a *shore polynya* or by *fast ice* and is called a *flaw polynya*. If it recurs in the same position every year, it is called a *recurring polynya*.

Puddle: An accumulation on ice of melt-water, mainly due to melting snow, but in the more advanced stages also to the melting of ice. Initial stage consists of patches of melted snow.

Rafted ice: Type of *deformed ice* formed by one piece of ice overriding another.

Rafting: Pressure processes whereby one piece of ice overrides another. Most common in *new* and *young ice*.

Ram: An underwater ice projection from an *ice wall*, *ice front*, *iceberg*, or *floe*. Its formation is usually due to a more intensive melting and erosion of the unsubmerged part.

Recurring polynya: A *polynya* which recurs in the same position every year.

Ridge: A line or wall of broken ice forced up by pressure. May be fresh or weathered. The submerged volume of broken ice under a ridge, forced downwards by pressure, is termed an *ice keel*.

Ridged ice: Ice piled haphazardly one piece over another in the form of ridges or walls. Usually found in first-year ice.

Ridged-ice zone: An area in which much *ridged ice* with similar characteristics has formed.

Ridging: The pressure process by which *sea ice* is forced into *ridges*.

River ice: Ice formed on a river, regardless of observed location.

Rotten ice: *Sea ice* which has become honeycombed and which is in an advanced state of disintegration.

Sastrugi: Sharp, irregular ridges formed on a snow surface by wind erosion and deposition. On mobile *floating ice* the ridges are parallel to the direction of the prevailing wind at the time they were formed.

Sea ice: Any form of ice found at sea which has originated from the freezing of sea water.

Second-year ice: *Old ice* which has survived only one summer's melt. Because it is thicker and less dense than *first-year ice*, it stands higher out of the water. In contrast to *multi-year ice*, summer melting produces a regular pattern of numerous small *puddles*. Bare patches and puddles are usually greenish-blue.

Shearing: An area of *pack ice* is subject to shear when the ice motion varies significantly in the direction normal to the motion, subjecting the ice to rotational forces. These forces may result in phenomena similar to a *flow*.

Shore lead: A *lead* between *pack ice* and the shore or between *pack ice* and an *ice front*.

Shore polynya: A *polynya* between *pack ice* and the coast or between *pack ice* and an *ice front*.

Shuga: An accumulation of spongy white ice lumps, a few centimeters across; they are formed from *grease ice* or *slush* and sometimes from *anchor ice* rising to the surface.

Skylight: From the point of view of the submariner, thin places in the *ice canopy*, usually less than 1 m thick and appearing from below as relatively light, translucent patches in dark surroundings. The under-surface of a skylight is normally flat. Skylights are called large if big enough for a submarine to attempt to surface through them (120 m), or small if not.

Slush: Snow which is saturated and mixed with water on land or ice surfaces, or as a viscous floating mass in water after a heavy snowfall.

Small floe: (see *Floe*).

Small fracture: 50 to 200 m wide.

Small ice cake: An ice cake less than 2 m across.

Small ice field: An *ice field* 10-15 km across.

Snow-covered ice: Ice covered with snow.

Snowdrift: An accumulation of wind-blown snow deposited in the lee of obstructions or heaped by wind eddies. A crescent-shaped snowdrift, with ends pointing down-wind, is known as a snow barchan.

Standing floe: A separate *floe* standing vertically or inclined and enclosed by rather smooth ice.

Stranded ice: Ice which has been floating and has been deposited on the shore by retreating high water.

Strip: Long narrow area of *pack ice*, about 1 km or less in width, usually composed of small fragments detached from the main mass of ice, and run together under the influence of wind, swell, or current.

Tabular berg: A flat-topped *iceberg*. Most tabular bergs form by *calving* from an *ice shelf* and show horizontal banding.

Thaw holes: Vertical holes in *sea ice* formed when surface *puddles melt* through to the underlying water.

Thick first-year ice: *First-year ice* 30-70 cm thick.

Tide crack: Crack at the line of junction between an immovable *ice foot* or *ice wall* and *fast ice*, the latter subject to rise and fall of the tide.

Tongue: A projection of the ice edge up to several kilometers in length, caused by wind or current.

Vast floe: (see *Floe*).

Very close pack ice: *Pack ice* in which the *concentration* is 9/10 to less than 10/10 (7/8 to less than 8/8).

Very open pack ice: *Pack ice* in which the *concentration* is 1/10 to 3/10 (1/8 to less than 3/8) and water preponderates over ice.

Very small fracture: 0 to 50 m wide.

Very weathered ridge: *Ridge* with tops very rounded, slope of sides usually 20° - 30°.

Water sky: Dark streaks on the underside of low clouds, indicating the presence of water features in the vicinity of *sea ice*.

Weathered ridge: *Ridge* with peaks slightly rounded and slope of sides usually 30° to 40°. Individual fragments are not discernible.

Weathering: Processes of ablation and accumulation which gradually eliminate irregularities in an ice surface.

White ice: See *Thin first-year ice*.

Young coastal ice: The initial stage of *fast ice* formation consisting of *nilas* or *young ice*, its width varying from a few meters up to 100-200 m from the shoreline.

Young ice: Ice in the transition stage between *nilas* and *first-year ice*, 10-30 cm in thickness. May be subdivided into *grey ice* and *grey-white ice*.

SHIP RESEARCH COMMITTEE
Maritime Transportation Research Board
National Academy of Sciences - National Research Council

The SHIP RESEARCH COMMITTEE has technical cognizance of the interagency Ship Structure Committee's research program.

Mr. A. D. Haff, Chairman, *Consultant, Annapolis, MD*
Prof. A. H.-S. Ang, *Civil Engrg. Dept., University of Illinois, Champaign, IL*
Dr. K. A. Blenkarn, *Research Director, Offshore Technology, Amoco Production Company, Tulsa, OK*
Mr. D. Price, *Sr. Systems Analyst, National Oceanic and Atmospheric Administration, Rockville, MD*
Mr. D. A. Sarno, *Manager-Mechanics, ARMCO Inc., Middletown, OH*
Prof. H. E. Sheets, *Dir. of Engineering, Analysis & Technology, Inc., Stonington, CT*
Mr. J. E. Steele, *Naval Architect, Quakertown, PA*
Mr. R. W. Rumke, *Executive Secretary, Ship Research Committee*

The SHIP DESIGN, RESPONSE, AND LOAD CRITERIA ADVISORY GROUP prepared the project prospectus and evaluated the proposals for this project.

Mr. J. E. Steele, Chairman, *Naval Architect, Quakertown, PA*
Mr. J. W. Boylston, *Consulting Naval Architect, Giannotti & Associates, Inc., Annapolis, MD*
Prof. R. G. Davis, *Assistant Professor of Naval Architecture, Dept. of Marine Engrg., Texas A&M University, Galveston, TX*
Mr. P. W. Marshall, *Civil Engineering Advisor, Shell Oil Company, Houston, TX*
Prof. R. Plunkett, *Dept. of Aerospace Engrg. and Mechanics, University of Minnesota, Minneapolis, MN*
Mr. C. B. Walburn, *Assistant Naval Architect, Bethlehem Steel, Corp., Marine Division, Sparrows Point, MD*

The SR-1267 *ad hoc* PROJECT ADVISORY COMMITTEE provided the liaison technical guidance, and reviewed the project reports with the investigator.

Mr. W. J. Lane, Chairman, *Consultant, Baltimore, MD*
Mr. L. R. Glosten, *L. R. Glosten Associates, Inc., Seattle, WA*
Mr. P. M. Kimon, *EXXON International Co., Florham Park, NJ*
Mr. P. W. Marshall, *Civil Engrg., Advisor, SHELL Oil Co., Houston, TX*
Mr. J. E. Steele, *Naval Architect, Quakertown, PA*

SHIP STRUCTURE COMMITTEE PUBLICATIONS

These documents are distributed by the National Technical Information Service, Springfield, VA 22314. These documents have been announced in the Clearinghouse Journal U. S. Government Research & Development Reports (USGRDR) under the indicated AD numbers.

- SSC-300, *Summary of Nondestructive Inspection Standards for Heavy Section Castings, Forgings, and Weldments* by R. A. Youshaw. 1980. AD-A099119.
- SSC-301, *Probabilistic Structural Analysis of Ship Hull Longitudinal Strength* by J. C. Daidola and N. S. Basar. 1981. AD-A099118.
- SSC-302, *Computer-Aided Preliminary Ship Structural Design* by A. E. Marsow and A. Thayamballi. 1981. AD-A099113.
- SSC-303, *Fatigue and Fracture Toughness Characterization of SAW and SMA A537 Class I Ship Steel Weldments* by J. F. Souak, J. W. Caldwell, and A. K. Shoemaker. 1981.
- SSC-304, *SL-7 Extreme Stress Data Collection and Reduction* by E. T. Booth. 1981.
- SSC-305, *Investigation of Steels for Improved Weldability in Ship Construction - Phase II* by B. G. Reisdorf and W. F. Domis. 1981.
- SSC-306, *Experimental Program for the Determination of Hull Structural Damping Coefficients* by P. Y. Chang and T. P. Carroll. 1981.
- SSC-307, *Evaluation of Fracture Criteria for Ship Steels and Weldments* by A. W. Pense. 1981.
- SSC-308, *Criteria for Hull-Machinery Rigidity Compatibility* by W. I. H. Budd, S. V. Karve, J. G. de Oliveira, and P. C. Xirouchakis. 1981.
- SSC-309, *A Rational Basis for the Selection of Ice Strengthening Criteria for Ships - Vol. I* by J. L. Coburn, F. W. DeBord, J. B. Montgomery, A. M. Nawwar, and K. E. Dane. 1981.
- SSC-310, *A Rational Basis for the Selection of Ice Strengthening Criteria for Ships - Vol. II - Appendices* by J. L. Coburn, F. W. DeBord, J. B. Montgomery, A. M. Nawwar, and K. E. Dane. 1981.
- SSC-311, *Evaluation of SL-7 Scratch-Gauge Data* by J. C. Oliver. 1981.
- SSC-312, *Investigation of Internal Corrosion and Corrosion-Control Alternatives in Commercial Tankships* by L. C. Herring, Jr. and A. N. Titcomb. 1981.
- SSC-313, *SL-7 Research Program Summary, Conclusions and Recommendations* by K. A. Stambaugh and W. A. Wood. 1981.