

SSC-323

**UPDATING OF FILLET WELD STRENGTH PARAMETERS FOR
COMMERCIAL SHIPBUILDING**

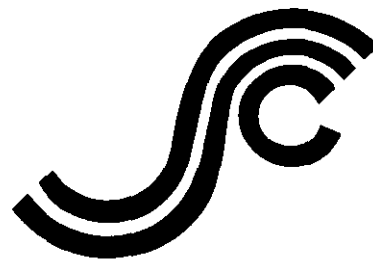

This document has been approved
for public release and sale; its
distribution is unlimited

SHIP STRUCTURE COMMITTEE

1984

SSC-323 UPDATING OF FILLET WELD STRENGTH PARAMETERS FOR COMMERCIAL SHIPBUILDING 1984

CONTRACTOR TO ADJUST
AS NECESSARY

486-330 - BACKSTRIP s/s

78-707211

SHIP STRUCTURE COMMITTEE

THE SHIP STRUCTURE COMMITTEE is constituted to prosecute a research program to improve the hull structures of ships and other marine structures by an extension of knowledge pertaining to design, materials and methods of construction.

RADM C. T. Lusk, Jr., USCG (Chairman)
Chief, Office of Merchant Marine
Safety
U. S. Coast Guard Headquarters

Mr. T. W. Pross
Associate Administrator for
Shipbuilding, Operations &
Research
Maritime Administration

Mr. P. M. Palermo
Executive Director
Ship Design & Integration
Directorate
Naval Sea Systems Command

Mr. J. B. Gregory
Chief, Technology Assessment
& Research Branch
Minerals Management Service

Mr. W. M. Hannan
Vice President
American Bureau of Shipping

Mr. T. W. Allen
Engineering Officer
Military Sealift Command

CDR D. B. Anderson, U. S. Coast Guard (Secretary)

SHIP STRUCTURE SUBCOMMITTEE

The SHIP STRUCTURE SUBCOMMITTEE acts for the Ship Structure Committee on technical matters by providing technical coordination for the determination of goals and objectives of the program, and by evaluating and interpreting the results in terms of structural design, construction and operation.

U. S. COAST GUARD

CAPT A. E. HENN
CAPT J. R. WALLACE
MR. J. S. SPENCER
MR. R. E. WILLIAMS

MILITARY SEALIFT COMMAND

MR. D. STEIN
MR. T. W. CHAPMAN
MR. A. ATTERMAYER
MR. A. B. STAVOVY

NAVAL SEA SYSTEMS COMMAND

MR. J. B. O'BRIEN (CHAIRMAN)
CDR R. BUBECK
MR. J. E. GAGORIK
MR. A. H. ENGLE
MR. S. G. ARNTSON (COTR)
MR. G. WOODS (COTR)

AMERICAN BUREAU OF SHIPPING

DR. D. LIU
MR. I. L. STERN
MR. B. NADALIN

MINERALS MANAGEMENT SERVICE

MR. R. GIANGERELLI
MR. R. C. E. SMITH

MARITIME ADMINISTRATION

MR. F. SEIBOLD
MR. N. O. HAMMER
DR. W. M. MACLEAN
MR. M. W. TOUMA

INTERNATIONAL SHIP STRUCTURES CONGRESS

MR. S. G. STIANSEN - LIAISON

AMERICAN IRON & STEEL INSTITUTE

MR. J. J. SCHMIDT - LIAISON

NATIONAL ACADEMY OF SCIENCES
COMMITTEE ON MARINE STRUCTURES

MR. A. DUDLEY HAFF - LIAISON
MR. R. W. RUMKE - LIAISON

STATE UNIVERSITY OF NY MARITIME COLLEGE

DR. W. R. PORTER - LIAISON

SOCIETY OF NAVAL ARCHITECTS &
MARINE ENGINEERS

MR. N. O. HAMMER - LIAISON
MR. F. SELLARS - LIAISON

U.S. COAST GUARD ACADEMY

LT J. TUTTLE - LIAISON

U.S. NAVAL ACADEMY

DR. R. BHATTACHARYYA - LIAISON

WELDING RESEARCH COUNCIL

DR. G. W. OYLER - LIAISON

U.S. MERCHANT MARINE ACADEMY

DR. C. B. KIM - LIAISON

1 3/4" TO TRIM

(1 1/2" TO TRIM)

Committee on Marine Structures
Marine Board
National Academy of Sciences - National Research Council

The Committee on Marine Structures has technical cognizance of the Interagency Ship Structure Committee's research program.

- Mr. A. D. Haff, Chairman, Annapolis, MD
- Prof. A. H.-S. Ang, University of Illinois, Champaign, IL
- Dr. K. A. Blenkarn, Amoco Production Company, Tulsa, OK
- Mrs. Margaret Ochi, Gainesville, PA
- Mr. D. Price, National Oceanic and Atmospheric Administration, Rockville, MD
- Mr. D. A. Sarno, ARMCO Inc., Middletown, OH
- Mr. J. E. Steele, Naval Architect, Quakertown, PA
- Mr. R. W. Rumke, Executive Secretary, Committee on Marine Structures

LOADS ADVISORY GROUP

The Loads Advisory Group prepared the project prospectus.

- Mr. J. E. Steele, Chairman, Quakertown, PA
- Prof. R. G. Davis, Texas A&M University, Galveston, TX
- Mr. J. P. Fischer, American Steamship Company, Buffalo, NY
- Mr. P. W. Marshall, Shell Oil Co., Houston, TX
- Prof. Robert Plunkett, Univ. of Minnesota, Minneapolis, MN
- Mr. C. B. Walburn, Bethlehem Steel Corp., Sparrows Point, MD

PROJECT ADVISORY COMMITTEE

The Project Advisory Committee provided the liaison technical guidance, and reviewed the project with the investigator.

SR-1286

- Mr. J. E. Steele, Chairman, Quakertown, PA
- Prof. R. G. Davis, Texas A&M University, Galveston, TX
- Dr. J. E. Goldberg, National Science Foundation, Washington, DC
- Mr. A. D. Haff, Annapolis, MD

486-330 - COVER 3

S/S

1 1/4" TO BAND

1 1/4" TO TRIM

SHIP STRUCTURE COMMITTEE PUBLICATIONS

3/4" TO TRIM

- SSC-316 Ship Structure Committee Long-Range Research Plan: Guidelines for Program Development by E.M. MacCutcheon, O.H. Oakley and R.D. Stout, 1983, AD-A140275
- SSC-317 Determinsation of Strain Rates in Ship Hull Structures: A Feasibility Study by J. G. Giannotti and K. A. Stambaugh, 1984
- SSC-318 Fatigue Characterization of Fabricated Ship Details for Design by W. H. Munse, T. W. Wilbur, M. L. Tellalian, K. Nicoll and K. Wilson, 1983, AD-A140338
- SSC-319 Development of A Plan to Obtain In-Service Still-Water Bending Moment Information for Statistical Characterization by J. W. Boylston and K. A. Stambaugh, 1984
- SSC-320 A Study of Extreme Waves and Their Effects on Ship Structures by W. H. Buckley, 1983, AD-A140317
- SSC-321 Survey of Experience Using Reinforced Concrete in Floating Marine Structures by O.H. Burnside and D.J. Pomerening, 1984
- SSC-322 Analysis and Assessment of Major Uncertainties Associated With Ship Hull Ultimate Failure by P. Kaplan, M. Benatar, J. Bentson and T.A. Achtarides, 1984
- SSC-323 Updating of Fillet Weld Strength Parameters for Commercial Shipbuilding by R.P. Krumpen, Jr., and C.R. Jordan, 1984
- SSC-324 Analytical Techniques for Predicting Grounded Ship Response by J.D. Porricelli and J.H. Boyd, 1984
- SSC-325 Correlation of Theoretical and Measured Hydrodynamic Pressures for the SL-7 Containership and the Great Lakes Bulk Carrier S. J. Cort by H.H. Chen, Y.S. Shin & I.S. Aulakh, 1984
- SSC-326 Long-Term Corrosion Fatigue of Welded Marine Steels by O.H. Burnside, S.J. Hudak, E. Oelkers, K. Chan, and R.J. Dexter, 1984
- None Ship Structure Committee Publications - A Special Bibliography, AD-A140339

486-330 - COVER 4

3/5

1" TO TRIM

Member Agencies:

United States Coast Guard
Naval Sea Systems Command
Maritime Administration
American Bureau of Shipping
Military Sealift Command
Minerals Management Service



**Ship
Structure
Committee**

An Interagency Advisory Committee
Dedicated to the Improvement of Marine Structures SR-1286

Address Correspondence to:

Secretary, Ship Structure Committee
U.S. Coast Guard Headquarters, (G-M/TP 13)
Washington, D.C. 20593
(202) 426-2197

3/8" TO BIND

This report presents a possible alternate method of assessing fillet weld requirements vis-a-vis the American Bureau of Shipping (ABS) weld tables. The recommended methodology is demonstrated on previous designs of a tanker, an OBO and a containership. Results point to cost savings of from 9 to 15 percent of welding costs.

Certainly these results are worthy of further consideration. However, as always, specific designs must be approved by the appropriate authorities.

CLYDE T. LUSK Jr.
Rear Admiral, U.S. Coast Guard
Chairman, Ship Structure Committee

486-330 - (1) (2 BLANK)

95%

1. Report No. SSC-323		2. Government Accession No.		3. Recipient's Catalog No.	
4. Title and Subtitle UPDATING OF FILLET WELD STRENGTH PARAMETERS FOR COMMERCIAL SHIPBUILDING				5. Report Date April, 1983	
				6. Performing Organization Code BA 117960	
7. Author(s) R. P. Krumpen, Jr. and C. R. Jordan				8. Performing Organization Report No. 1025M	
9. Performing Organization Name and Address Newport News Shipbuilding 4101 Washington Avenue Newport News, Virginia 23607				10. Work Unit No. (TRAVIS)	
				11. Contract or Grant No. DTCG23-81-C-20030	
12. Sponsoring Agency Name and Address U.S. Coast Guard Ship Structure Committee 2100 Second Street, S.W. U.S. Coast Guard Hdqtrs. Washington, D.C. 20593 Washington, D.C. 20590				13. Type of Report and Period Covered Final Report Oct. 1981 to April 1983	
				14. Sponsoring Agency Code SR-1286	
15. Supplementary Notes					
16. Abstract A new procedure for sizing fillet welds for commercial ship structures is developed in this report. First the weld sizes required to develop the full strength of tee type connections are developed including appropriate corrosion allowances. Service experience data is included by determining the joint efficiencies in the current American Bureau of Shipping (ABS) weld tables. ABS welds are resized and put in a form which is easier to use in a design office, easier to compare to other rule weld sizes, and should help guide further weld size reduction research although significant further reductions in commercial ship fillet weld sizes are not anticipated. In general, the current ABS fillet weld sizes are not excessively conservative so the proposed reductions are relatively small. The new design criteria is applied to three sample ships showing order of magnitude weld cost savings of 9 to 15 percent.					
17. Key Words Fillet Weld Shear Weld Sizing Electrodes Strength Joint Efficiencies Stress			18. Distribution Statement Document is available to the U.S. public through the National Technical Information Service, Springfield, Va. 22161		
19. Security Classif. (of this report) UNCLASSIFIED		20. Security Classif. (of this page) UNCLASSIFIED		21. No. of Pages 204	22. Price

METRIC CONVERSION FACTORS

Approximate Conversions to Metric Measures

Symbol	When You Know	Multiply by	To Find	Symbol
LENGTH				
in	inches	2.5	centimeters	cm
ft	feet	30	centimeters	cm
yd	yards	0.9	meters	m
mi	miles	1.6	kilometers	km
AREA				
in ²	square inches	6.5	square centimeters	cm ²
ft ²	square feet	0.09	square meters	m ²
yd ²	square yards	0.8	square meters	m ²
mi ²	square miles	2.6	square kilometers	km ²
	acres	0.4	hectares	ha
MASS (weight)				
oz	ounces	28	grams	g
lb	pounds	0.45	kilograms	kg
	short tons (2000 lb)	0.9	tonnes	t
VOLUME				
tsp	teaspoons	5	milliliters	ml
Tbsp	tablespoons	15	milliliters	ml
fl oz	fluid ounces	30	milliliters	ml
c	cups	0.24	liters	l
pt	pints	0.47	liters	l
qt	quarts	0.95	liters	l
gal	gallons	3.8	liters	l
ft ³	cubic feet	0.03	cubic meters	m ³
yd ³	cubic yards	0.76	cubic meters	m ³
TEMPERATURE (exact)				
°F	Fahrenheit temperature	5/9 (after subtracting 32)	Celsius temperature	°C

* 1 in = 2.54 (exactly). For other exact conversions and more detailed tables, see NBS Misc. Publ. 286, Units of Weights and Measures, Price \$2.25, SD Catalog No. C13.10.286.

Approximate Conversions from I

Symbol	When You Know	Multiply by
LENGTH		
mm	millimeters	0.04
cm	centimeters	0.4
m	meters	3.3
m	meters	1.1
km	kilometers	0.6
AREA		
cm ²	square centimeters	0.16
m ²	square meters	1.2
km ²	square kilometers	0.4
ha	hectares (10,000 m ²)	2.6
MASS (weight)		
g	grams	0.035
kg	kilograms	2.2
t	tonnes (1000 kg)	1.1
VOLUME		
ml	milliliters	0.03
l	liters	2.1
l	liters	1.06
l	liters	0.26
m ³	cubic meters	35
m ³	cubic meters	1.3
TEMPERATURE (exact)		
°C	Celsius temperature	9/5 (then add 32)

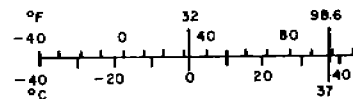

486-330-4

17

CONTENTS

	<u>Page</u>
ABSTRACT	i
CONTENTS	ii
LIST OF FIGURES	iii
LIST OF TABLES	iv
SYMBOLS	vi
1. INTRODUCTION	1-1
2. DEVELOPMENT OF PROPOSED DESIGN CRITERIA	2-1
2.1 Loadings on Fillet Welds	2-1
2.2 Stresses in Welds Loaded in Longitudinal Shear	2-1
2.3 Stresses in Welds Loaded in Transverse Shear	2-5
2.4 Existing Navy Formula and Fillet Weld Sizes for ABS Steels	2-7
2.5 Fillet Weld Sizes Using Proposed Criteria	2-7
2.6 Effect of Uniform Corrosion	2-16
2.7 Equivalent Fillet Sizes for Intermittent Welds	2-16
3. EFFICIENCIES OF ABS FILLET WELDS	3-1
3.1 Grouping of ABS Fillet Welds	3-1
3.2 Efficiencies	3-1
3.3 Proposed Efficiencies and Weld Size Tables	3-4
4. DIRECT CALCULATION OF WELD SIZES	4-1
5. USE OF PROPOSED DESIGN CRITERIA	5-1
5.1 Tee Type Joints	5-1
5.2 Lap Joints and Corner Type Joints	5-3
5.3 Slightly Unbalanced Welds	5-3
5.4 Construction Tolerances	5-3
5.5 Minimum Weld Sizes	5-6
5.6 Intermittent Versus Continuous Welding.	5-7
5.7 Special Protective Coatings	5-10
6. APPLICATION OF PROPOSED DESIGN CRITERIA TO SAMPLE SHIPS	6-1
6.1 General Procedure	6-1
6.2 Voyager Class Tanker	6-2

CONTENTS (Cont'd)

<u>Chapter</u>	<u>Page</u>
6.3 Vanguard Class Containership	6-3
6.4 Crescent Class Ore/Bulk/Oil Carrier	6-3
6.5 Fillet Weld Comparisons	6-4
6.6 Cost Saving Estimates	6-5
7. SUMMARY AND CONCLUSIONS	7-1
8. RECOMMENDATIONS	8-1
REFERENCES	R-1
ACKNOWLEDGMENTS	R-2
APPENDICES	
A. ABS FILLET WELD SIZES	A-1
B. GROUPING OF ABS FILLET WELDS	B-1
C. PLOTS OF ABS AND PROPOSED FILLET WELD SIZES	C-1
D. PROPOSED FILLET WELD SIZE TABLES	D-1
E. CALCULATIONS FOR VOYAGER CLASS TANKER	E-1
F. CALCULATIONS FOR VANGUARD CLASS CONTAINERSHIP	F-1
G. CALCULATIONS FOR CRESCENT CLASS ORE/BULK/OIL CARRIER	G-1

LIST OF FIGURES

1. Double Fillet Weld Loaded in Longitudinal Shear	2-2
2. Double Fillet Weld Loaded in Transverse Shear	2-2
3. Throat Failure Plane - Transverse Shear Load	2-3
4. Intercostal Member HAZB Failure Plane - Transverse Shear Load	2-3
5. Failure Planes of a Double Fillet Weld Loaded in Longitudinal Shear	2-4
6. Failure Planes of a Double Fillet Weld Loaded in Transverse Shear	2-6
7. Covered Electrode Strength Values	2-10
8. Bare Electrode Strength Values	2-10
9. Weld Sizes Versus Plate Thickness for Constant Efficiencies As Originally Welded	2-15
10. Uniform Corrosion on Fillet Welds	2-17
11. Weld Sizes Versus Plate Thickness for Constant Efficiencies After 0.060 Inch Per Surface Corrosion	2-18
12. Comparison of Weld Sizes for Weld Groups M and M1 With and Without Corrosion Allowance	3-5

LIST OF FIGURES (Cont'd)

13. Efficiencies as Originally Welded of Proposed Efficiency Categories Which Include Corrosion Allowances	3-6
14. Load Deflection Curve of Fillet Welded Beam Simulating Unbracketed Fixed End Connection	4-2
15. Load and Absorbed Energy Versus End Connection Joint Efficiency From Figure 14	4-2
16. Double Fillet Weld In Way of a "Backed Up" Member	5-2
17. Double Fillet Weld In Way of a Corner Joint - Case 1	5-4
18. Double Fillet Weld In Way of a Corner Joint - Case 2	5-4
19. Example of a Slightly Unbalanced Fillet Weld	5-5
20. Comparison of AWS, Reference (13), and Proposed Minimum Weld Sizes	5-8
21. Comparison of Sample Ship Calculated and Proposed Tabular Weld Sizes for Connection of Bottom Longitudinals to Shell Plate	5-9
22. Weld Length Versus Efficiency Category for Sample Ships	6-6
23. Weld Weight Versus Efficiency Category for Sample Ships	6-7
24. Fillet Weld Relative Cost Curves	6-8
25. Fillet Weld Relative Cost Curves for Test Series	6-9

LIST OF TABLES

	<u>Page</u>
1. 100 Percent Efficient Double Fillet Weld Sizes for ABS Steels Using Procedure of NAVSHIPS 0900-014-5010 [Reference (3)]	2-8
2. 100 Percent Efficient Double Fillet Weld Sizes for ABS Steels for Longitudinal Shear Loading Using Proposed Criteria	2-11
3. 100 Percent Efficient Double Fillet Weld Sizes for ABS Steels for Transverse Shear Loading Using Proposed Criteria	2-12
4. Comparison of Weld Sizes for 100 Percent Efficient Double Fillet Welds for ABS Steels Using Navy Procedure [Reference (3)] and Proposed Criteria	2-13
5. Efficiencies of ABS Double Continuous Fillet Welds When Corroded 0.060 Inch Per Surface	3-2
6. Efficiencies of ABS Intermittent Fillet Welds When Corroded 0.060 Inch Per Surface	3-3
7. Comparison of Weld Joint Efficiency Categories	3-4

LIST OF TABLES (Cont'd)

8. Comparison of Proposed and ABS Fillet Weld Sizes Versus Plate Thickness	3-8
9. Principal Characteristics of Sample Ships	6-1
10. Summary of Lengths, Sizes, and Weights of Welds for Voyager Class Tanker	6-2
11. Summary of Lengths, Sizes, and Weights of Welds for Vanguard Class Containership	6-3
12. Summary of Lengths, Sizes, and Weights of Welds for Crescent Class Ore/Bulk/Oil Carrier	6-4
13. Double Fillet Weld Comparisons for Sample Ships	6-4
14. Fillet Weld Cost Savings for Sample Ships Using Derived Cost Curve and 3.00 \$/Foot for 1/4 Inch Double Fillet Welds	6-10

SYMBOLS

- C = Corrosion allowance
- D = Fillet weld size as originally welded
D_C = Fillet weld size when corroded
D_i = Continuous fillet weld size equivalent
of an intermittent fillet weld with no corrosion
D_{iC} = Continuous fillet weld size equivalent of an
intermittent fillet weld with a corrosion
allowance
- E = Joint efficiency as originally welded
E_C = Joint efficiency when corroded
- L = Length of intermittent fillet welds
- RC = Relative cost of fillet welds in percent
- S = Spacing of intermittent fillet welds
- T = Original plate thickness
T_C = Plate thickness when corroded
T_r = Plate thickness required for a given load
- HAZB = Boundary line between fillet weld heat affected
zone and base material
-
- σ = Tensile stress (KSI)
- σ_{uc} = Ultimate tensile stress of continuous material
 σ_{ui} = Ultimate tensile stress of intercostal material
 σ_{uw} = Ultimate tensile stress of weld metal
-
- τ = Shear stress (KSI)
- τ_{uc} = Ultimate shear stress of continuous material
 τ_{ui} = Ultimate shear stress of intercostal material
 τ_{wl} = Weld metal ultimate longitudinal shear stress
 τ_{wt} = Weld metal ultimate transverse shear stress

1. INTRODUCTION

A recent Ship Structure Committee report [SSC-296, Reference 1] illustrates the variety of fillet weld sizes which can be obtained for ship structural connections by using various existing rules from:

- o the American Bureau of Shipping (ABS),
- o other classification societies,
- o the U.S. Navy,
- o the American Welding Society (AWS), and
- o the American Institute of Steel Construction (AISC).

However, the comparisons in Reference 1 are somewhat limited. For example, only ten weld locations are compared while the current ABS Rules list weld sizes for 96 different locations and Lloyd's Register lists about 93. A given structural connection can require different weld sizes depending on its location in the ship (e.g., in the peaks or flat of bottom forward versus amidships), location in the member (e.g., center versus ends of a span), or tightness (e.g., watertight versus nontight). In addition, the various rules specify their minimum requirements in different forms. Some means of weighting the importance of a given line item to the overall cost of all the fillet welds on a typical ship is also needed. Therefore, it is very difficult to make reasonable comparative judgments on the various rules without an extensive effort.

Reference 1 recommends an extensive analysis of fillet welds by finite element techniques to determine minimum sizes along with "photoelastic, or similar stress analysis, experiments . . . to check the validity of the mathematical modeling and computer results" [page 43, Reference 1]. Before such work is started, it would appear most desirable to first analyze the current ABS weld tables in detail using methods which have been verified by actual weld joint tests to better identify the potential candidates for weld size reduction. That is the objective of this report which uses a simple engineering design approach, verified by testing, to characterize ABS fillet weld sizes and to put them in a more useful form for comparison with other rules or everyday use in a design office. This approach should aid further research by allowing such research to concentrate on more important aspects of the problem such as the question of what joint efficiencies are appropriate to the many different joint configurations and locations in a typical merchant

ship. This simpler approach will also help ship designers by giving them a better "feel" for the joint strengths required than the current method of choosing sizes from an extensive welding table and by giving them better insight on how to handle unusual configurations. It should be kept in mind that the work in this report is a study proposed for the design and selection of ABS welds. It is not a fabrication document and the use of this report in sizing any fillet welds under ABS jurisdiction is subject to ABS approval prior to use in actual construction.

Since this report is a proposed design procedure, it, like all design procedures, assumes that proper fabrication procedures and techniques will be applied to produce the specified welds. Thus, it should not restrict those contractors who can meet the requirement - rather - it should provide the acceptable design limitations, minimum and maximum, of the procedure. Also, if consideration is to be given to producibility and cost-effective measures in an effort to be competitive with others, it is necessary to provide those in design and construction with the tools they need. For example, the proposed procedure indicates a minimum weld size of 1/8"; it also allows a 3/16" maximum fit-up gap with a 1/8" increase in the size of the weld. Thus, the required design weld size becomes 1/4" which generally can be made with a single pass weld. If, on the other hand, the design process indicated a 3/16" fillet as the minimum size, the same alignment condition would require a 5/16" fillet which generally requires a double pass weld. This would result in an increase in weld metal deposited plus the expense of an additional weld pass. Where a 3/16" or a 1/4" weld is the smallest that can actually be deposited, then a built in allowance will exist for fit-up gaps that are equal to or less than 1/8" and 3/16", respectively. Thus, the welder would not be required by a design procedure to deposit excessive weld metal. Minimum weld sizes are discussed further in Section 5.5 with recommendations at the end of the report.

Briefly, this report first resolves some of the differences between the ABS and U.S. Navy rules by sizing the welds for ABS steels with a method which is more rigorous than the current Navy method. It is well known that the strength of a given size double fillet weld varies with the direction of loading. The existing Navy fabrication documents recognize the effect of loading direction but do not take advantage of it in order to simplify the process of sizing fillet welds. This fillet weld sizing proposal will account for the effect of loading direction in a manner which is still sufficiently conservative to ensure that properly fabricated welds will uniformly develop the required design strength of the members being joined.

Fillet welds are generally sized based on the "weaker" member at a joint. However, the determination of which member is "weaker" is also a function of the loading direction. In addition, there are cases where the "weaker" member as so defined really has little impact on the required strength of the fillet welds. Therefore, a new criteria is presented wherein the weld for tee type joints will usually be sized based on the thickness of the intercostal or non-continuous member of the joint.

The base material properties used in this report are minimum specification values taken from Reference 2. Appropriately modified weld strength data from References 3 through 6 have been used because weld longitudinal shear strength data for commercial electrodes on ABS steels were not readily available. Thus, it is assumed that commercial electrodes will have essentially the same shear strengths as the comparable series military specification electrodes. The material and weld strength values used with the proposed procedure must be on the same basis: either minimum values or average values; not a combination of the two.

After considering the effects of corrosion and intermittent welding, the joint efficiencies of the welds in the current ABS rules are determined to provide guidance on efficiencies which have given successful performance in the past. Then the ABS weld groups are assigned proposed minimum efficiencies and the welds resized. This produces new weld size tables which are more consistent than some of the current ABS weld size tables. Also, since equations are now available, the weld sizes can be readily determined for thicknesses greater than those in the current ABS weld size tables.

Using three sample ships, weld sizes are determined from both the current ABS and the proposed weld size tables. In addition, calculations are performed using ABS rule loadings for typical highly loaded fillet welded connections. Weld lengths, weights, and weighted average sizes are determined to allow budgetary cost saving estimates to be made and to allow an assessment to be made of the potential for further reductions in ABS fillet weld sizes.

2. DEVELOPMENT OF PROPOSED DESIGN CRITERIA

In this section, formulas for calculating nominal stresses in fillet welds are developed and applied to typical ABS steel combinations. The resulting fillet weld sizes are compared to those which would be obtained from the existing Navy procedure. The effect of uniform corrosion on joint efficiencies is determined along with equivalent sizes for intermittent fillet welds.

2.1 Loadings on Fillet Welds

Double fillet welds can be loaded in either of two basic ways: in longitudinal shear as shown in Figure 1 or in transverse shear as shown in Figure 2. The basic concern in sizing critical fillet welds is to ensure that the welds will develop the full strength of the joined members. In the longitudinal shear case, the weld need only develop the ultimate shear strength of the intercostal member; whereas, in the transverse shear case, the weld must develop the ultimate tensile strength of the intercostal member. Fillet welds usually fail along a plane through the throat, as shown in Figure 3. However, there is sufficient variation in the strengths of the base metals for the cases at hand that it is also possible for failure to occur along the heat-affected-zone boundary (HAZB)¹ between the intercostal member and the weld, as shown in Figure 4. In addition, the strength along the HAZB between the continuous member and the weld should be checked, especially when higher strength steels are involved. Therefore, the strength of the weld along three failure planes for each of the two loading conditions must be checked. It is assumed in all cases that adequate fusion has occurred between the base metal and the weld metal.

It would appear that the primary problem with previous design equations for fillet welds is their attempt to account for six possible failure modes with a single equation. References 3 through 5 appear to make an attempt in a few cases to account for alternate failure modes by varying the allowed electrode strength with different material combinations. However, that method is difficult to use because it requires adequate test data for every possible combination of materials and electrodes. Therefore, the new design procedure uses a different equation for each of the six possible failure modes. Although it is a bit more laborious, the calculations need only be done once for each material and electrode combination.

2.2 Stresses in Welds Loaded in Longitudinal Shear

The failure planes for double fillet welds loaded in longitudinal shear are shown by dashed lines in Figure 5. For this loading it is required that the weld develop the full ultimate shear strength of the intercostal member (plane aa). For failure in the throat of the weld (planes ob), the minimum required double fillet weld size is:

(1) Symbols used throughout this report are identified on page vi.

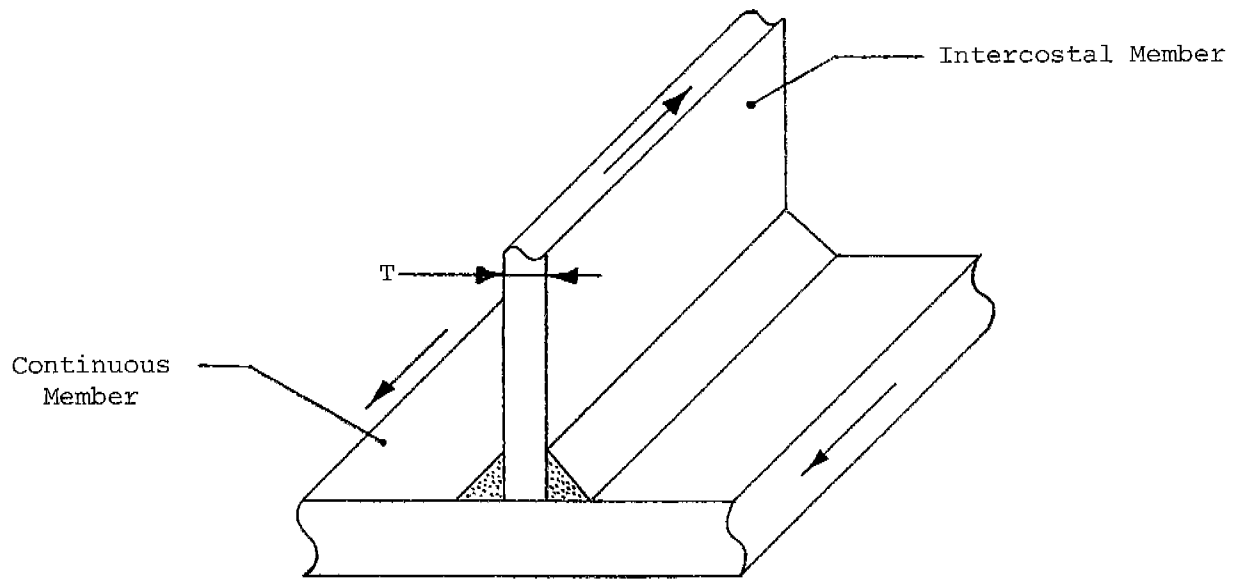

FIGURE 1

Double-Fillet Weld Loaded
in Longitudinal Shear

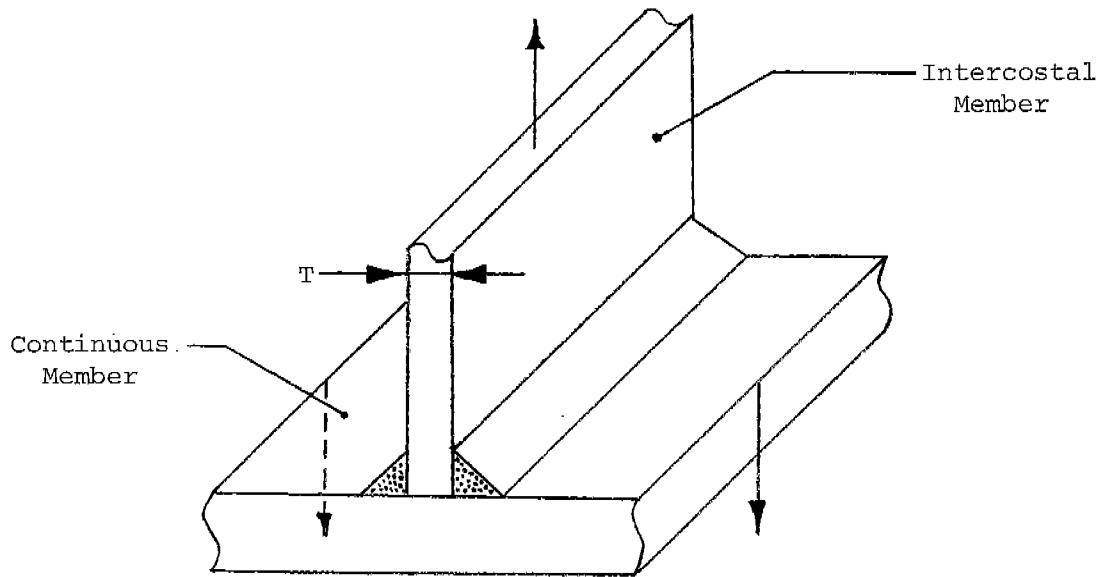
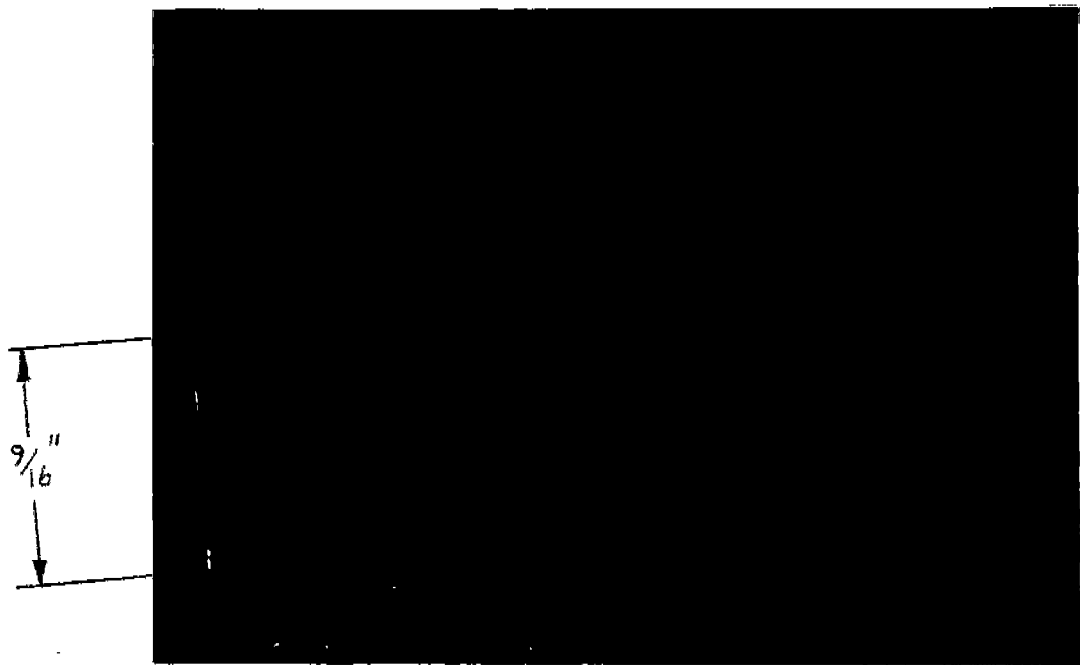

FIGURE 2

Double-Fillet Weld Loaded
in Transverse Shear

2-2



1a

FIGURE 3

Throat Failure Plane - Transverse Shear Load

See planes cdo of Figure 6



2a

FIGURE 4

Intercostal Member HAZB Failure Plane - Transverse Shear Load

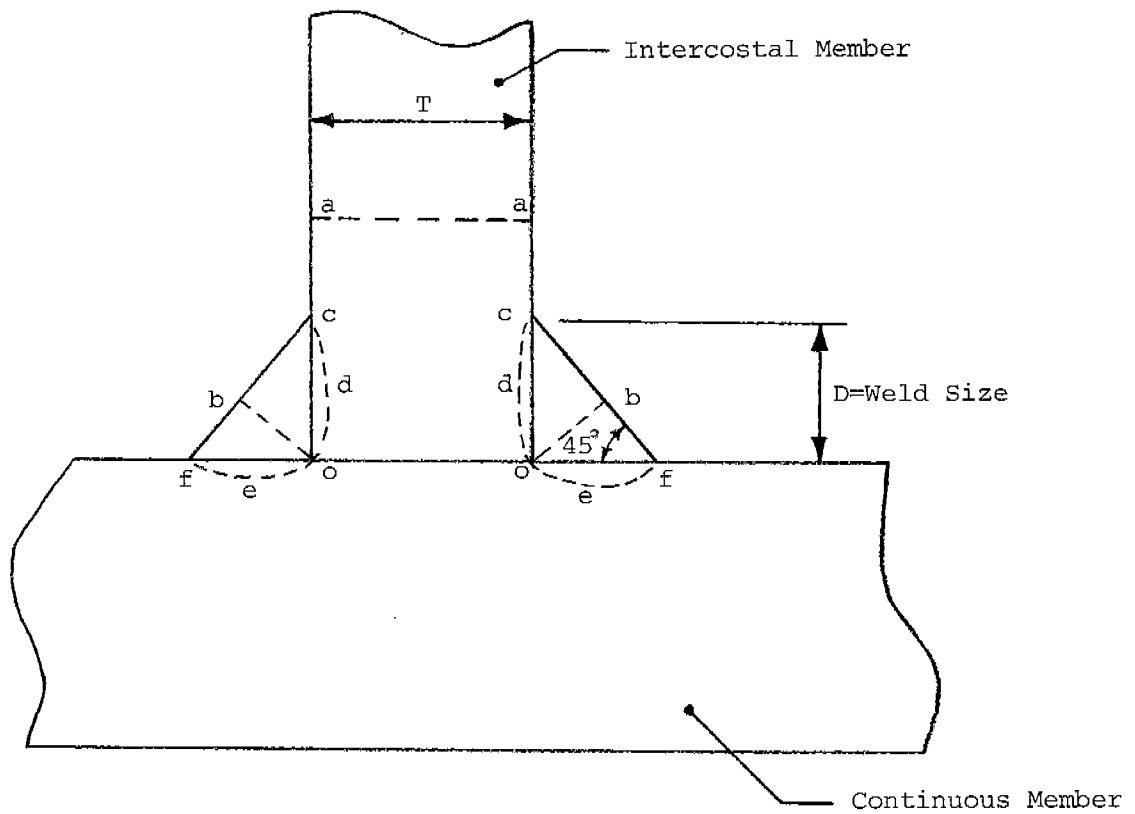

FIGURE 5

Failure Planes of a Double Fillet Weld
Loaded in Longitudinal Shear

$$2 \times D \times \sin 45^\circ \times \tau_{wl} = T \times \tau_{ui}, \text{ or}$$

$$D/T = 0.707 \times \tau_{ui} / \tau_{wl}. \quad (1)$$

For failure along either HAZB , the length of the failure plane may be conservatively taken as $1.1 \times D$ to account for a small amount of weld penetration into the base material [see Figure 4 and page 3-36 of Reference 9]. For failure along the intercostal member HAZB (planes cdo),

$$2 \times D \times 1.1 \times \tau_{ui} = T \times \tau_{ui}, \text{ or}$$

$$D/T = 0.455 . \quad (2)$$

For failure along the continuous member HAZB (planes oef),

$$2 \times D \times 1.1 \times \tau_{uc} = T \times \tau_{ui}, \text{ or}$$

$$D/T = 0.455 \times \tau_{ui} / \tau_{uc}. \quad (3)$$

As long as a double fillet weld is equal to or larger than the greatest value of equations (1), (2), or (3), it will develop the full ultimate shear strength of the intercostal member.

2.3 Stresses in Welds Loaded in Transverse Shear

The transverse shear loading case is slightly more complex than the longitudinal shear loading case. Both theory and experiments show that the failure plane within the weld is located at $22\text{-}1/2$ degrees from the intercostal member (planes oh) rather than 45 degrees (planes ob) [see Figures 3 and 6 and Reference 7]. However, in order to simplify the calculations, transverse weld shear stresses are customarily made with reference to the 45 degree plane. Adhering to this practice and basing the weld size on the ultimate tensile strength of the intercostal member (plane aa), the minimum required double fillet weld size for failure in the throat of the weld is:

$$2 \times D \times \sin 45^\circ \times \tau_{wt} = T \times \sigma_{ui}, \text{ or}$$

$$D/T = 0.707 \times \sigma_{ui} / \tau_{wt}. \quad (4)$$

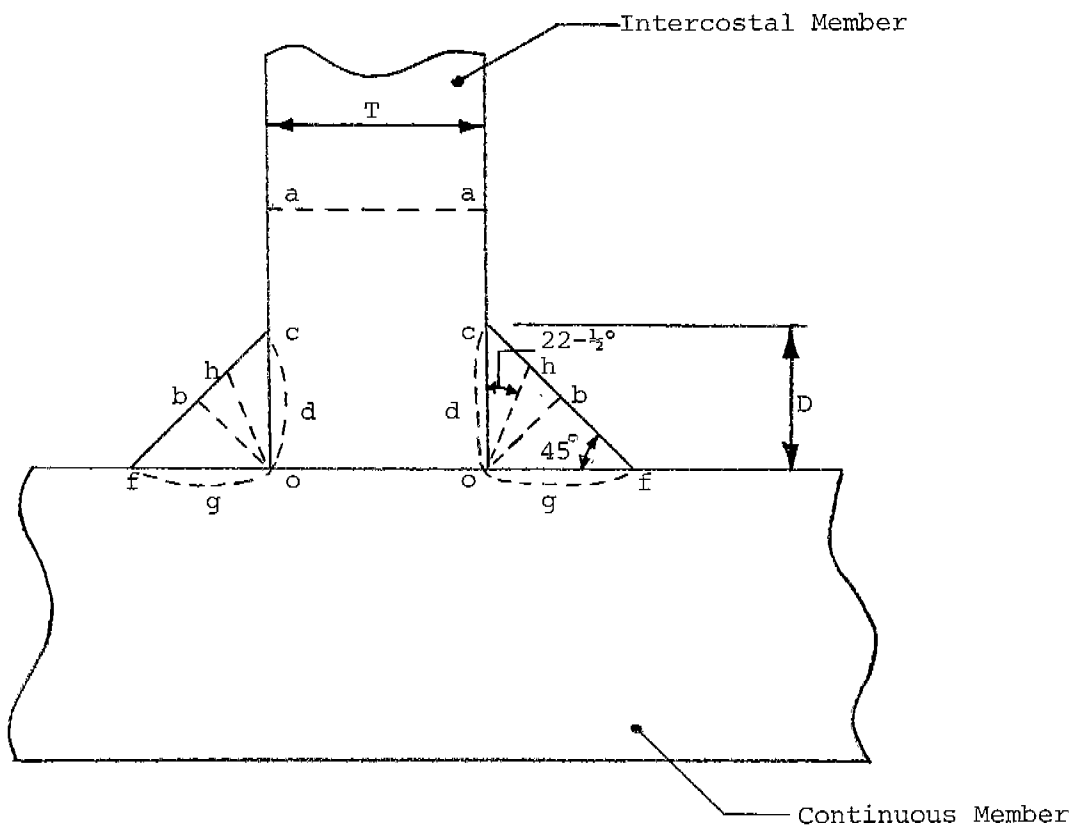

FIGURE 6

Failure Planes of a Double Fillet Weld
Loaded in Transverse Shear

For failure along the intercostal member HAZB (planes cdo),

$$2 \times D \times 1.1 \times \tau_{ui} = T \times \sigma_{ui}, \text{ or}$$
$$D/T = 0.455 \times \sigma_{ui} / \tau_{ui}. \quad (5)$$

For this transverse loading, the continuous member HAZB (planes ogf) will be either in tension or compression. Therefore, the projected length of the HAZB (i.e., D) should be used rather than the 1.1 x D used previously. For failure along the continuous member HAZB,

$$2 \times D \times \sigma_{uc} = T \times \sigma_{ui}, \text{ or}$$
$$D/T = 0.5 \times \sigma_{ui} / \sigma_{uc}. \quad (6)$$

As long as a double fillet weld is equal to or larger than the greatest value of equations (4), (5), and (6), it will develop the full ultimate tensile strength of the intercostal member.

2.4 Existing Navy Formula and Fillet Weld Sizes for ABS Steels

The formula which is currently used by the Navy for sizing double fillet welds is essentially a combination of the more rigorous equations (1) and (4) using the most conservative values from each equation. That is, the weld is sized using the ultimate tensile strength of the intercostal member and the longitudinal shear strength of the weld. This formula [see References 3 through 6] expressed in the symbols used in this report is:

$$2 \times D \times \sin 45^\circ \times \tau_{wl} = T \times \sigma_{ui}, \text{ or}$$
$$D/T = 0.707 \times \sigma_{ui} / \tau_{wl}. \quad (7)$$

It should be evident that this equation can only be defended on the basis that it is normally conservative because it is not possible to load the intercostal member in tension in a manner that will fail the weld in longitudinal shear in a typical ship structural connection.

Applying equation (7) to typical material combinations and electrodes for ABS steels results in double fillet weld sizes as shown in column 6 of Table 1.

2.5 Fillet Weld Sizes Using Proposed Criteria

In order to utilize the more rigorous equations (1) through (6), only two additional properties are required: the ultimate shear strength of the base

TABLE 1

100 Percent Efficient Double Fillet Weld Sizes
for ABS Steels Using Procedure of
NAVSHIPS 0900-014-5010 [Reference 3]

1	2	3	4	5	6
Materials Intercostal-Continuous	Electrode	σ_{ui} (KSI) (1)	τ_{wl} (KSI)	Figure No. [Reference (3)]	$D/T = 0.707 \frac{\sigma_{ui}}{\tau_{wl}}$
H36 - H36	MIL 8018	71	60.7	11-41	0.827
H36 - MS	MIL 8018	71	60.7	SIM 11-45	0.827
H36 - H36	MIL 7018	71	59.2	11-39	0.848
H36 - MS	MIL 7018	71	58.1	SIM 11-43	0.864
H32 - H32	MIL 8018	68	60.7	11-41	0.792
H32 - MS	MIL 8018	68	60.7	SIM 11-45	0.792
H32 - H32	MIL 7018	68	59.2	11-39	0.812
H32 - MS	MIL 7018	68	58.1	SIM 11-43	0.827
MS - H36	MIL 8018	58	60.7	11-45	0.676
MS - H32	MIL 8018	58	60.7	11-45	0.676
MS - H36	MIL 7018	58	58.1	11-43	0.706
MS - H32	MIL 7018	58	58.1	11-43	0.706
MS - MS	MIL 7018	58	58.1	11-51	0.706
MS - MS	MIL 60xx	58	46.4	11-49	0.884

Note: (1) See Tables 43.1 and 43.2 of Reference 2 for other base material properties.

materials and the transverse shear strength of the weld metals. Experiments show that the ultimate shear strength of most steels varies from 2/3 to 3/4 of the ultimate tensile strength [page 10, Reference 10]. Since the fillet weld sizes for the longitudinal shear loading on the weld will be a direct function of the ultimate shear strength of the intercostal member, it will be conservative to use the higher value or:

$$\tau_{ui} = 0.75 \sigma_{ui}, \text{ and} \quad (8)$$

$$\tau_{uc} = 0.75 \sigma_{uc}. \quad (9)$$

With this assumption, it will be noted that equation (1) will always govern over equation (4) provided the weld transverse shear strength is greater than 1.33 times the weld longitudinal shear strength. Both theory and tests give ratios of 1.44 to 1.56 for transverse to longitudinal weld shear strength [References 7 and 8]. It will be conservative to use the smaller value or:

$$\tau_{wt} = 1.44 \times \tau_{wl}. \quad (10)$$

Weld shear strength values from References 3 and 6 are shown in Figure 7 for covered electrodes and in Figure 8 for bare electrodes. The shear strength values are plotted versus the ultimate tensile strength of the weld metal. It should be noted that there is a wide variation in the published values and many seem inconsistent. For example, the values from Reference 3 for MIL 9018 and 11018 electrodes vary with material combinations, whereas the values for MIL 8018 and 10018 electrodes do not. Also, the value from Reference 6 for MIL 11018 is greater than the value specified for MIL 12018 which clearly seems inconsistent. Based on these comparisons and other test results, it has been concluded that the maximum values acceptable for use with minimum specified material properties and the proposed design procedure are:

$$\tau_{wl} = 1.8 (\sigma_{uw})^{0.8} \text{ for covered electrodes, and} \quad (11)$$

$$\tau_{wl} = 2.5 (\sigma_{uw})^{0.75} \text{ for bare electrodes.} \quad (12)$$

For covered electrodes below the 9000 series, a simpler equation is sufficiently accurate:

$$\tau_{wl} = 10.25 + 0.625 \sigma_{uw}. \quad (11a)$$

With the assumptions of equations (8), (9), and (10), the double fillet weld sizes required by equations (1) through (6) for ABS steels using weld properties from equation (11a) are shown in Table 2 for longitudinal shear and in Table 3 for transverse shear. The weld size which governs is indicated with an asterisk. A comparison of these weld sizes with the sizes required by the Navy procedure is presented in Table 4 which shows that reductions of from

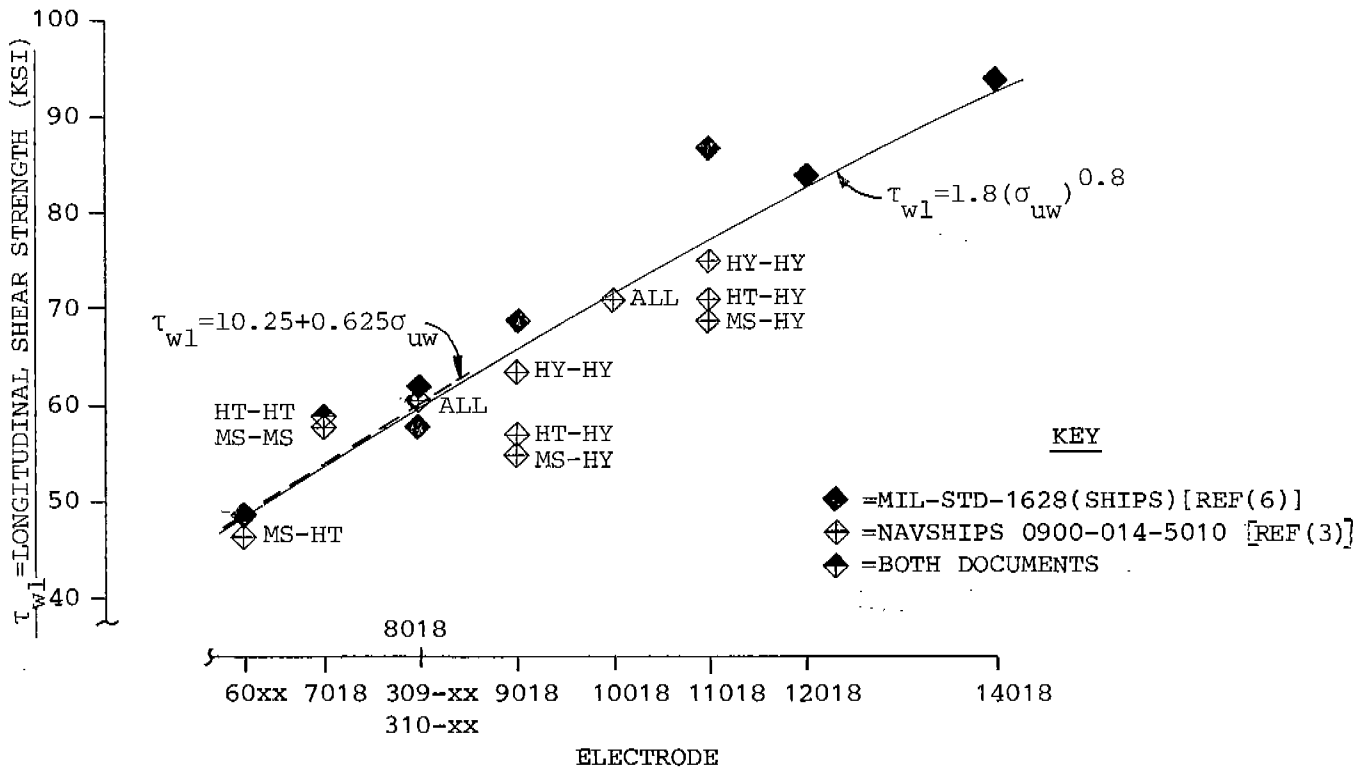

FIGURE 7
COVERED ELECTRODE STRENGTH VALUES

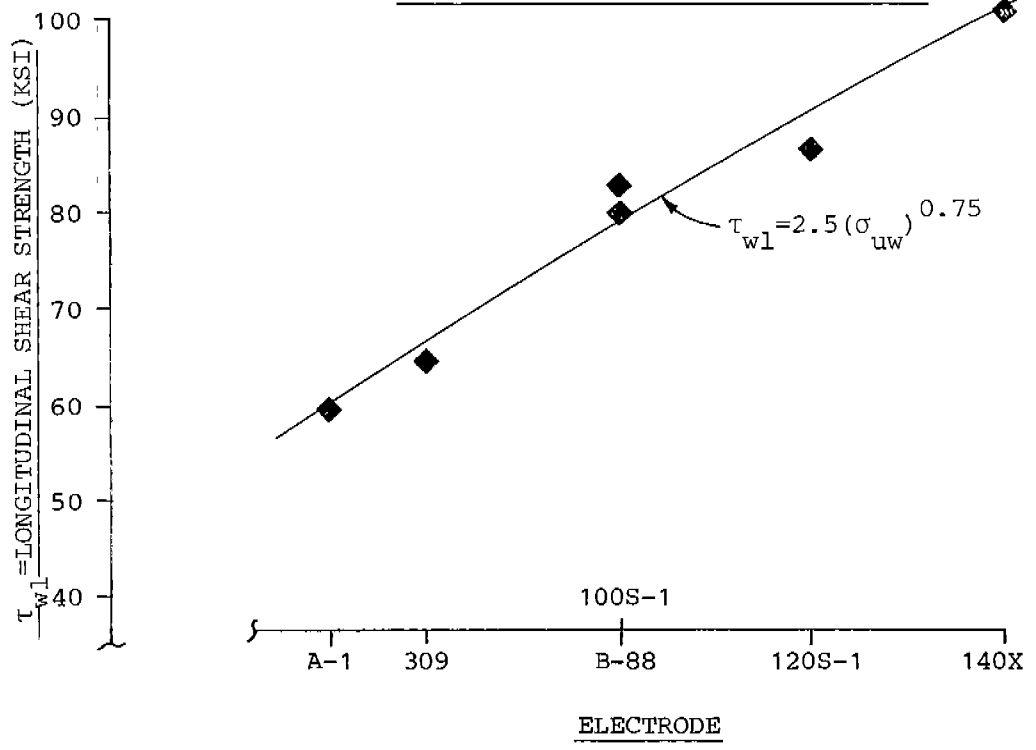

FIGURE 8
BARE ELECTRODE STRENGTH VALUES

TABLE 2

100 Percent Efficient Double Fillet Weld Sizes For ABS Steels for Longitudinal Shear Loading Using Proposed Criteria

1	2	3	4	5	6	7	8	9
Materials Intercostal-Continuous	Electrode	Intercostal Member		Weld	Continuous Member	Required Minimum D/T		
		σ_{ui} (KSI)	$\tau_{ui}=0.75 \sigma_{ui}$ (KSI)	τ_{wl} (KSI)	$\tau_{uc}=0.75 \sigma_{uc}$ (KSI)	HAZB Shear @ Intercostal = 0.455	Throat Shear = $0.707 \frac{\tau_{ui}}{\tau_{wl}}$	HAZB Shear @ Continuous = $0.455 \frac{\tau_{ui}}{\tau_{uc}}$
H36 - H36	MIL 8018	71	53.3	60.2	53.3	0.455	0.626*	0.455
H36 - MS	MIL 8018	71	53.3	60.2	43.5	0.455	0.626*	0.558
H36 - H36	MIL 7018	71	53.3	54	53.3	0.455	0.698*	0.455
H36 - MS	MIL 7018	71	53.3	54	43.5	0.455	0.698*	0.558
H32 - H32	MIL 8018	68	51	60.2	51	0.455	0.599	0.455
H32 - MS	MIL 8018	68	51	60.2	43.5	0.455	0.599	0.533
H32 - H32	MIL 7018	68	51	54	51	0.455	0.668*	0.455
H32 - MS	MIL 7018	68	51	54	43.5	0.455	0.668*	0.533
MS - H36	MIL 8018	58	43.5	60.2	53.3	0.455	0.511	0.371
MS - H32	MIL 8018	58	43.5	60.2	51	0.455	0.511	0.388
MS - H36	MIL 7018	58	43.5	54	53.3	0.455	0.570	0.371
MS - H32	MIL 7018	58	43.5	54	51	0.455	0.570	0.388
MS - MS	MIL 7018	58	43.5	54	43.5	0.455	0.570	0.455
MS - MS	MIL 60xx	58	43.5	49	43.5	0.455	0.628*	0.455

- NOTES: 1. The weld size in Table 2 or 3 which governs is indicated with an asterisk.
 2. Column 7 uses equation (2).
 3. Column 8 uses equation (1).
 4. Column 9 uses equation (3).

486-330-25

TABLE 3
100 Percent Efficient Double Fillet Weld Sizes for ABS Steels for Transverse
Shear Loading for Using Proposed Criteria

1	2	3	4	5	6	7	8	9
Materials Intercostal-Continuous	Electrode	Instl Mbr.	Weld		Continuous Member	Required Minimum D/T		
		σ_{ui} (KSI)	τ_{wl} (KSI)	Min. $\tau_{wt} =$ $1.44 \times$ τ_{wl} (KSI)	σ_{uc} (KSI)	HAZB Shear @ Intercostal = 0.607	Throat Shear = $0.707 \frac{\sigma_{ui}}{\tau_{wt}}$	HAZB Tension @ Continuous = $0.5 \frac{\sigma_{ui}}{\sigma_{uc}}$
H36 - H36	MIL 8018	71	60.2	86.7	71	0.607	0.579	0.500
H36 - MS	MIL 8018	71	60.2	86.7	58	0.607	0.579	0.612
H36 - H36	MIL 7018	71	54	77.8	71	0.607	0.645	0.500
H36 - MS	MIL 7018	71	54	77.8	58	0.607	0.645	0.612
H32 - H32	MIL 8018	68	60.2	86.7	68	0.607*	0.555	0.500
H32 - MS	MIL 8018	68	60.2	86.7	58	0.607*	0.555	0.586
H32 - H32	MIL 7018	68	54	77.8	68	0.607	0.618	0.500
H32 - MS	MIL 7018	68	54	77.8	58	0.607	0.618	0.586
MS - H36	MIL 8018	58	60.2	86.7	71	0.607*	0.473	0.408
MS - H32	MIL 8018	58	60.2	86.7	68	0.607*	0.473	0.426
MS - H36	MIL 7018	58	54	77.8	71	0.607*	0.527	0.408
MS - H32	MIL 7018	58	54	77.8	68	0.607*	0.527	0.426
MS - MS	MIL 7018	58	54	77.8	58	0.607*	0.527	0.500
MS - MS	MIL 60xx	58	49	70.6	58	0.607	0.581	0.500

- NOTES: 1. The weld size in Table 2 or 3 which governs is indicated with an asterisk.
2. Column 7 uses equations (5) and (8).
3. Column 8 uses equation (4).
4. Column 9 uses equation (6).

486-330-26

2-12

TABLE 4

Comparison of Weld Sizes for 100 Percent Efficient Double Fillet Welds for
ABS Steels Using Navy Procedure [Reference 3] and Proposed Criteria

1	2	3	4	5
Materials Intercostal-Continuous	Electrode	Weld Size Ref. 3 D/T	Weld Size from Proposed Criteria D/T	% Reduction
H36 - H36	MIL 8018	0.827	0.626	24%
H36 - MS	MIL 8018	0.827	0.626	24%
H36 - H36	MIL 7018	0.848	0.698	18%
H36 - MS	MIL 7018	0.864	0.698	19%
H32 - H32	MIL 8018	0.792	0.607	23%
H32 - MS	MIL 8018	0.792	0.607	23%
H32 - H32	MIL 7018	0.812	0.668	18%
H32 - MS	MIL 7018	0.827	0.668	19%
MS - H36	MIL 8018	0.676	0.607	10%
MS - H32	MIL 8018	0.676	0.607	10%
MS - H36	MIL 7018	0.706	0.607	14%
MS - H32	MIL 7018	0.706	0.607	14%
MS - MS	MIL 7018	0.706	0.607	14%
MS - MS	MIL 60xx	0.884	0.628	29%

10 to 29 percent are possible with this proposed criteria. This weld size variation of up to 29 percent is actually a hidden factor of safety in the current Navy procedure which should be eliminated precisely because it is hidden. It should also be eliminated because it is inconsistent in that it varies from 10 to 29 percent.

For longitudinal shear loading, the failure plane is the weld throat for all of the material and electrode combinations checked in Table 2. For transverse shear loading in Table 3, the failure plane is either the intercostal member HAZB or the weld throat. However, with a wider variation in material and electrode properties, each of the other three failure modes is still possible.

It should also be noted that significant weld size reductions are not obtained by using high-strength electrodes (i.e. 7018 and 8018) on mild steel intercostal members. The higher strength electrodes merely serve to shift the failure location from the throat of the weld to the intercostal member HAZB (compare column 8 of Table 2 with column 7 of Table 3).

Inspection of the proposed weld sizes (column 4 of Table 4) for the various ABS steels and welding electrode combinations shows remarkably small variations: from 0.607 to 0.698 times the intercostal member thickness. The required weld sizes could be conveniently grouped into two categories: one for mild steel intercostal members with a value of 0.628 and another for higher strength steel intercostal members with a value of 0.698. Then separate weld tables could be prepared for each group. Also, if higher strength steels than those shown in Table 4 are used, then additional calculations must be performed and additional weld size tables would probably be required.

The next step required is the determination of acceptable joint efficiencies. It is intended that a single set of joint efficiencies will be used for both mild steel and the current ABS higher strength steels. Since the current ABS weld tables have been used for both mild steel and ABS higher strength steels, the analysis of those tables will be based on the D/T value of 0.698. If the smaller D/T value of 0.628 were used, it would be equivalent to stating that the existing ABS weld tables are not acceptable for use with ABS higher strength steels.

Introducing a joint efficiency to account for locations which do not require the weld to develop the full shear or ultimate strength of the intercostal member gives the weld design equation:

$$D = 0.698 \times E \times T \quad (13)$$

A family of curves for various joint efficiencies is shown in Figure 9.

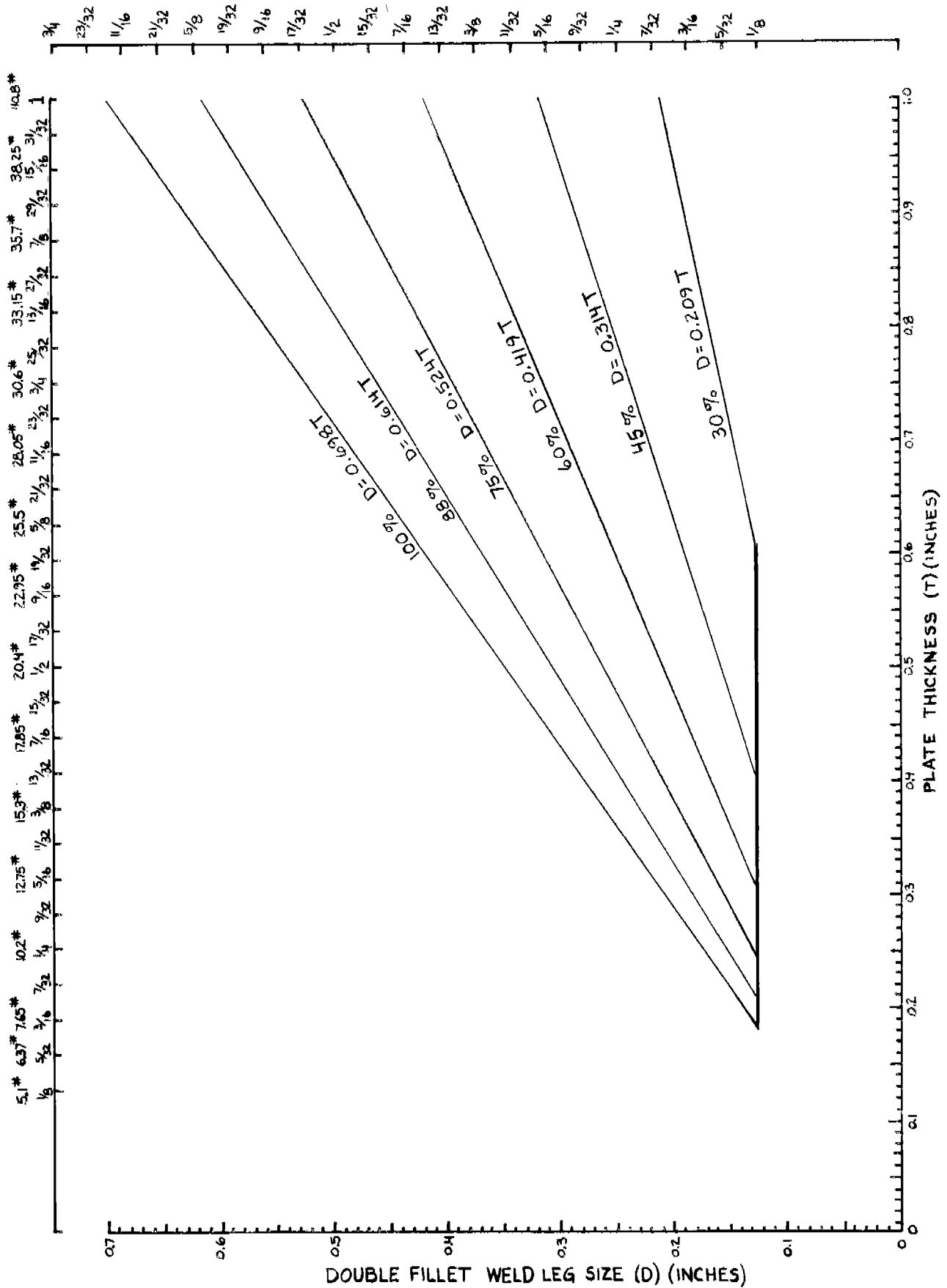

FIGURE 9

Weld Sizes Versus Plate Thickness for
Constant Efficiencies as Originally Welded
2-15

486-330

957
29

2.6 Effect of Uniform Corrosion

Since many of the required scantlings from the ABS rules contain allowances for uniform corrosion, the effect of such corrosion on joint strength must be determined. Figure 10 shows the geometry of such a condition. For a constant efficiency in the corroded condition (E_C), the weld size equation [equation (13)] becomes:

$$D_C = 0.698 \times E_C \times T_C, \text{ or}$$
$$D - 1.414C = 0.698 \times E_C \times (T - 2C).$$

An appropriate corrosion allowance appears to be about 0.060 inch per surface [Reference 1, page 16; or Reference 2, Sections 7.13.2, 12.7.1, 13.3.1, 13.7.2, 15.15.2, and 16.9.1]. Using this value, the design equation for constant efficiencies in the corroded condition becomes:

$$D = 0.698 \times E_C \times (T - 0.12") + 0.085". \quad (14)$$

A family of curves for various joint efficiencies using this equation is shown in Figure 11. A comparison of Figure 11 with Figure 9 shows that this amount of corrosion has essentially no effect on the strength of 100% efficient joints. That is, the decrease in strength of the weld almost exactly matches the loss in strength of the intercostal member. However, the curves in the two figures become progressively further apart as the efficiency decreases. The determination of which family of curves is most appropriate for ABS fillet welds is discussed further in Section 3.

2.7 Equivalent Fillet Sizes for Intermittent Welds

The final element needed before proceeding to a study of the existing ABS fillet weld tables is a means to compare the strengths of intermittent fillet welds to the strengths of continuous fillet welds. For this comparison, a continuous fillet size, D_i , which is equivalent in strength to a given intermittent fillet size, D , of length, L , and spacing, S , is determined:

$$D_{iC} = (D - 1.414C) \times L/S + 1.414C.$$

With no corrosion, this equation is simply:

$$D_i = D \times L/S. \quad (15)$$

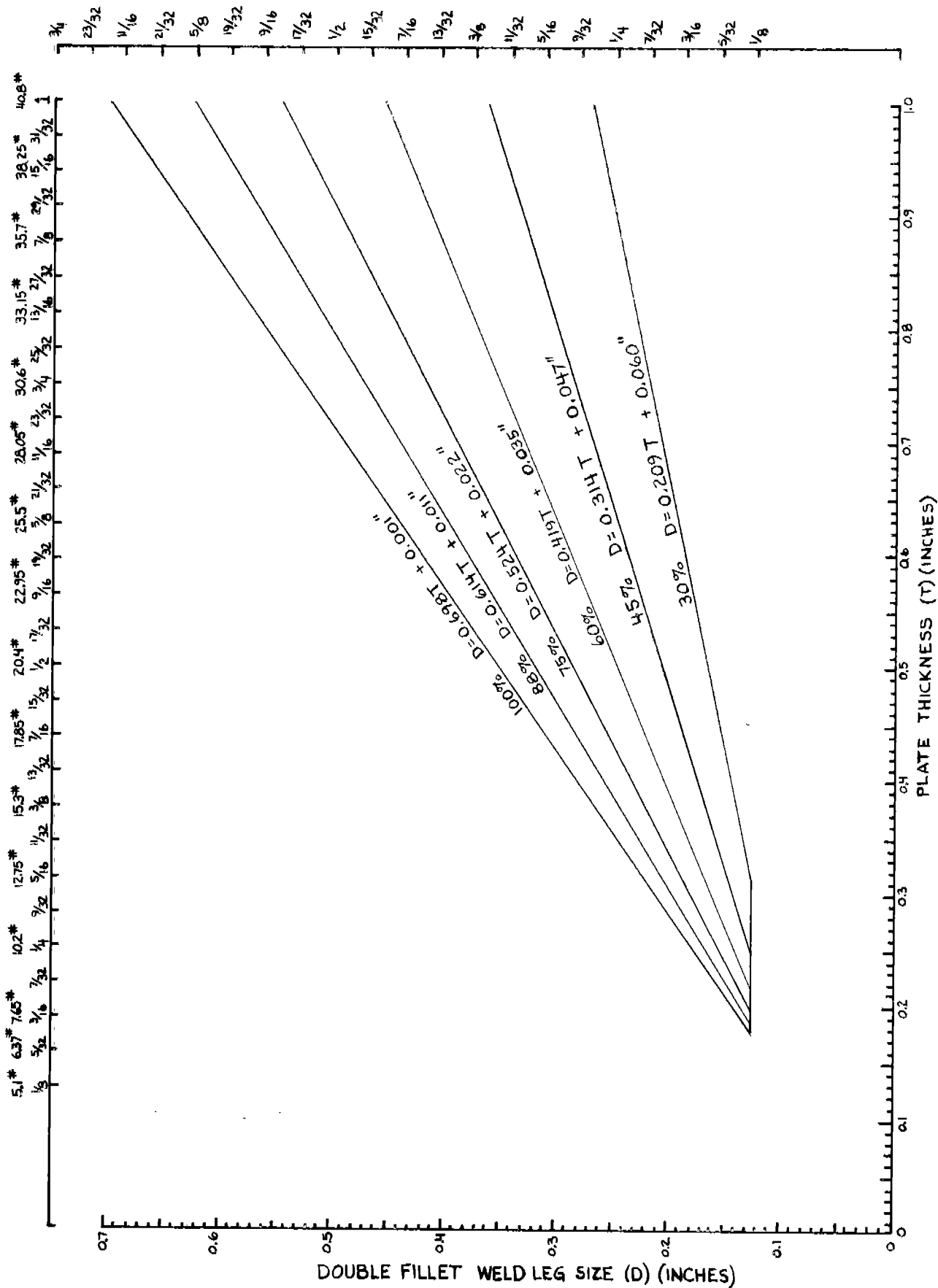

FIGURE 11

Weld Sizes Versus Plate Thickness for Constant Efficiencies
After 0.060 inch per Surface Corrosion

486-330

32

959

With 0.060 inch per surface corrosion allowance, the equivalent fillet size becomes:

$$D_{ic} = (D - 0.085") \times L/S + 0.085" \quad (16)$$

Calculations for typical intermittent fillet weld sizes are included in Table D-5 of Appendix D .

3. EFFICIENCIES OF ABS FILLET WELDS

Since the weld sizes required to develop the full strength of the connected members have now been determined, the next question to answer is what joint efficiencies are required for typical merchant ship structures. The Navy documents [References 3, 4, and 5] give tables of required efficiencies for naval ships which range from 50 to 100 percent with no corrosion allowance. In this section the joint efficiencies which exist in the current ABS rules are determined and used as a guide for specifying what efficiencies are appropriate to merchant ship structures.

3.1 Grouping of ABS Fillet Welds

The current ABS Rules list the required fillet weld size as a function of plate thickness and location of the connection as shown in Appendix A. In the Table for continuous welds shown in Appendix A, each of the 96 locations with its associated weld sizes has been assigned a unique line number. This table was then inspected and the line items with similar weld sizes were assigned to 18 weld groups as shown in Table 5 and Appendix B. There are 13 weld groups (A through M) for all ships with an additional 5 weld groups for vessels classed as oil carriers (N through R). In this grouping process, five line items (Nos. 7, 8, 38, 51, and 88) have had one weld size altered 1/32 inch in order to eliminate five additional weld groups.

The intermittent fillet weld table was then examined in a similar manner. Except for two special cases in weld group C, intermittent fillet welds are only permitted for the eight lessor efficiency weld groups: F, G, H, J, K, L, M, and R although these groups account for almost half of the line items. Three line items in the continuous weld table (numbers 53, 56, and 72) have two variations in the intermittent weld table (designated 53A, 53B, etc.). There is a much wider variation in sizes for the intermittent welds than the continuous welds even when minor adjustments to spacings are made and minor differences in the smallest sizes are neglected. For example, weld group M has five different variations in the intermittent fillet weld sizes. Consequently, the intermittent fillet weld sizes have been assigned to 15 weld groups as shown in Table 6 and Appendix B giving a total of 33 weld groups.

3.2 Efficiencies

The weld sizes for each of the 33 weld groups were then plotted versus plate thickness as shown in Appendix C. "Stepped" curves were used since the rules specify that intermediate plate thickness may use the weld size specified for the next lower plate thickness shown in the weld tables.

A decision then had to be made as to whether the proposed efficiencies should be based on the equations with a corrosion allowance [equations (14) and (16)] or those without a corrosion allowance [equations (13) and (15)]. Since the

TABLE 5

Efficiencies of ABS Double Continuous Fillet Welds
When Corroded 0.060 Inch Per Surface

ABS WELD GROUP	LINE NUMBERS	NO. OF LINES	EXIST. EFFICIENCIES			PROPOSED MIN. EFF. (%)
			MAX. (%)	RANGE (% POINTS)	MIN. (%)	
A	13, 51*	2	118	34	84	100
B	39, 52, 62, 69, 74, 76, 79, 82	8	98	24	74	75
C	1, 6, 11, 12, 14, 17, 20, 21, 23, 24, 30, 32, 34, 56, 57, 64, 65, 71, 72, 77	20	84	18	66	75
D	40, 42, 48, 63, 70, 75	6	74	15	59	60
E	66	1	80	29	51	45
F	2, 7*, 22, 26, 28, 35, 78, 80, 81	9	59	18	41	45
G	49	1	64	31	33	30
H	50	1	58	28	30	30
I	45	1	66	29	37	45
J	54	1	45	22	33	30
K	15, 16, 18, 19, 25	5	41	11	30	30
L	41	1	40	9	31	30
M	3, 4, 5, 8*, 9, 10, 27, 29, 31, 33, 36, 37, 38*, 43, 44, 46, 47, 53, 55, 58, 59, 60, 61, 67, 68, 73	26	40	10	30	30
N	83, 90, 91	3	102	20	82	88
O	85, 87, 93, 94	4	91	17	74	75
P	84, 92	2	79	15	64	60
Q	86, 88*, 95	3	68	14	54	60
R	89, 96	2	59	16	43	45
TOTAL . . .		96				

* One weld on each of these lines has been altered 1/32 inch in size to allow them to be classified in the weld groups shown.

TABLE 6

Efficiencies of ABS Intermittent Fillet Welds
When Corroded 0.060 Inch Per Surface

ABS WELD GROUP	LINE NUMBERS	NO. OF LINES	EXIST. EFFICIENCIES			PROPOSED MIN. EFF. (%)
			MAX. (%)	RANGE (% POINTS)	MIN. (%)	
C1	56B	1	-	-	-	Special Case
C2	72B	1	-	-	-	Special Case
F1	78,80,81	3	74	37	37	45
F2	2,7,35*	3	74	40	34	45
F3	22,26,28	3	74	36	38	45
G1 & J1	49,54	2	49	20	29	30
H1	50	1	44	19	25	30
K1	19	1	44	21	23	30
K2 & M3	15,27,29,31	4	40	19	21	30
K3 & L1	16,18,25,41	4	37	18	19	30
M1	10*,53B,55	3	44	19	25	30
M2	3,8,36,37,43,44	6	44	21	23	30
M4	4,5,9,33,38,46,47, 53A*,58,59,67,73	12	37	18	19	30
M5	60,61	2	37	20	17	30
R1	89,96	2	58	16	42	45
	TOTAL	48				

* One spacing in each of these lines has been altered to allow them to be classified in the weld groups shown.

corrosion problem mainly affects the least efficient welds, weld groups M and M1 were plotted together in Figure 12. From this figure it can be seen that the equations with corrosion allowances fit the ABS table weld sizes significantly better than those without a corrosion allowance. Consequently, it was decided that all further work would include a corrosion allowance.

Neglecting the 3/16 inch welds, which are the minimum size specified, the maximum and minimum efficiency of each ABS continuous fillet weld group was calculated. The results, which are shown in Table 5 and Appendix C, show a wide variation in efficiency, from 30 to 118% overall and up to 34 percentage points within a given weld group. Similar calculations were performed for intermittent fillet welds neglecting some of the smaller welds. These calculations, which are summarized in Table 6, give a variation in efficiency of 17 to 74% overall and up to 40 percentage points within a given weld group.

3.3 Proposed Efficiencies and Weld Size Tables

After several trials, it was determined that the 33 ABS weld groups could be reasonably represented by just six efficiency categories as shown in Tables 5 and 6 using the equations which include corrosion allowances. The six efficiency categories selected are shown in Table 7 along with the approximate equivalent joint efficiency as originally welded (i.e., no corrosion). These equivalent joint efficiencies can be compared to the standard Navy efficiency groups shown in the last column of Table 7 since the Navy groups have no corrosion allowance. From this comparison it can be seen that Navy fillet welds are still more conservative than ABS fillet welds even when the conservatism of equation (7) is removed (see Section 2.4).

TABLE 7

Comparison of Weld Joint Efficiency Categories

Proposed Efficiency Categories with Corrosion Allowance	Approximate Equivalent Efficiency as Originally Welded (see Figure 13)	Navy Efficiency Categories
100	100	100
88	90	
75	80	75
60	67	60
45	54	50
30	41	

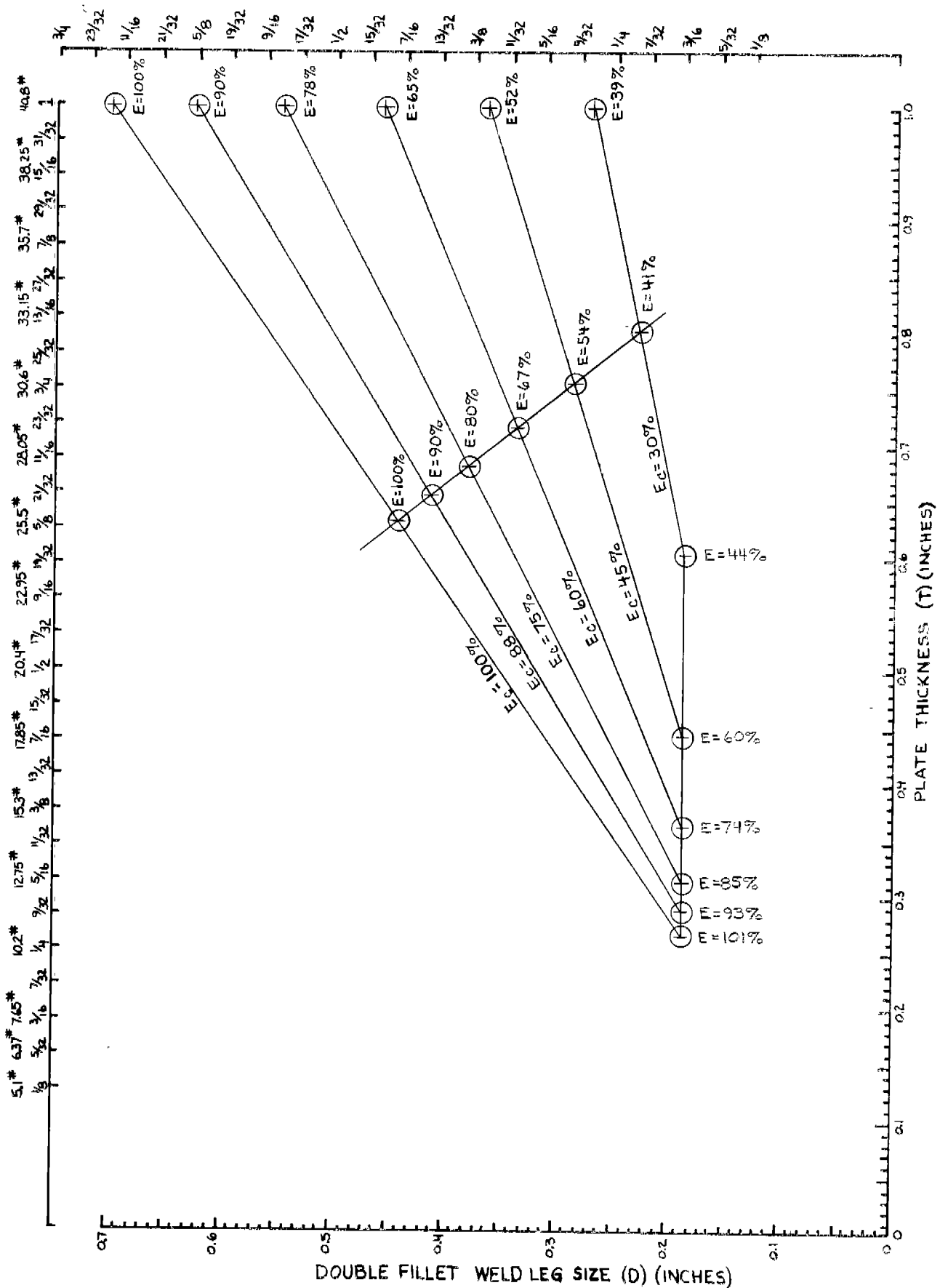

FIGURE 13

Efficiencies as Originally Welded of Proposed Efficiency Categories Which Include Corrosion Allowances

486-330

40

958

In addition to the comparison in Table 7, it should also be noted that the Navy generally requires a higher joint efficiency than ABS for many structural connections. For example, most unbracketed end connections must be 100% efficient by Navy requirements, whereas the ABS requirements are generally 80% efficient before corrosion. Also, most stiffening to plating supported joints must be 60% efficient by Navy requirements while the ABS requirements are generally 41% efficient before corrosion.

One other notable difference between ABS and Navy welding requirements is the lack of ABS guidelines for welding compensation for holes in structure. Navy requirements are 100% efficient joints for compensation in shell plating, stringer strakes of uppermost strength deck, and/or attached framing; 75% efficient joints for compensation in watertight, oiltight, or continuous bulkheads, decks, floors, and/or attached framing; and 50% efficient joints for compensation in non-tight structure.

The appropriate weld size equation is shown on each of the plots in Appendix C with the proposed increases or decreases in weld size crosshatched for emphasis. It should be noted that the proposed weld sizes are much more consistent than those in the current ABS weld tables. For example, most of the wide variations in weld sizes for weld groups G and H are eliminated. A further comparison of the proposed and ABS weld sizes versus standard plate thicknesses is given in Table 8.

The proposed weld sizes have been put in a more useful form in Appendix D. Line items which are essentially identical are combined as appropriate. This appendix contains essentially all the information required for everyday use in a design office. In Appendix D, Tables D-2 through D-5 along with Figures D-1 through D-4 have been based on the conservative D/T value of 0.698 so they can be used for either mild steel or current ABS higher strength steels. Table D-6 along with Figures D-5 and D-6 have been based on a D/T value of 0.628 so they can only be used for mild steel intercostal members. The size reduction for the latter table, neglecting round-off differences, is about 8%.

One additional comment on Table D-1 of Appendix D may be in order here. The line items for each structural item are arranged generally in descending order of required efficiency. The most critical joints (i.e., those with the highest required efficiency) then stand out rather distinctly. Although most inspectors probably have an excellent "feel" for which joints are most critical, perhaps this table will help identify to him which joints the designer considers most critical and thus the ones which should be given the closest inspection.

TABLE 8

Comparison of Proposed and ABS Fillet Weld Sizes Versus Plate Thickness

Proposed Eff. (%) or ABS Weld Group	Plate Thickness (t)														
	1/8	3/16	1/4	5/16	3/8	7/16	1/2	9/16	5/8	11/16	3/4	13/16	7/8	15/16	1
	5.1#	7.65#	10.2#	12.75#	15.3#	17.85#	20.4#	22.95#	25.5#	28.05#	30.6#	33.15#	35.7#	38.25#	40.8#
100% (D=0.698 T + 0.001")	1/8	5/32	3/16	1/4	9/32	5/16	3/8	13/31	7/16	1/2	17/32	19/32	5/8	21/32	23/32
A	3/16	3/16	3/16	7/32	1/4	5/16	3/8	7/16	7/16	1/2	17/32	19/32	5/8	11/16	3/4
75% (D=0.524 T + 0.022")	1/8	1/8	5/32	3/16	7/32	9/32	5/16	11/32	3/8	13/32	7/16	15/32	1/2	17/32	9/16
B	3/16	3/16	3/16	3/16	1/4	1/4	5/16	11/32	3/8	13/32	7/16	15/32	1/2	17/32	9/16
C	3/16	3/16	3/16	3/16	7/32	1/4	9/32	5/16	11/32	3/8	13/32	7/16	15/32	1/2	9/16
60% (D=0.419 T + 0.035")	1/8	1/8	5/32	3/16	7/32	7/32	1/4	9/32	5/16	11/32	3/8	13/32	13/32	7/16	15/32
D	3/16	3/16	3/16	3/16	3/16	7/32	1/4	5/16	5/16	3/8	3/8	7/16	7/16	1/2	17/32
45% (D=0.314 T + 0.047")	1/8	1/8	5/32	5/32	3/16	3/16	7/32	1/4	1/4	9/32	5/16	5/16	11/32	11/32	3/8
E	3/16	3/16	3/16	3/16	7/32	7/32	1/4	9/32	9/32	5/16	5/16	11/32	3/8	13/32	7/16
F	3/16	3/16	3/16	3/16	3/16	3/16	7/32	1/4	1/4	9/32	9/32	5/16	5/16	11/32	3/8
I	3/16	3/16	3/16	3/16	3/16	3/16	1/4	1/4	1/4	1/4	9/32	9/32	9/32	5/16	5/16
30% (D=0.209 T + 0.060")	1/8	1/8	1/8	5/32	5/32	5/32	3/16	3/16	7/32	7/32	7/32	1/4	1/4	9/32	9/32
G	3/16	3/16	3/16	3/16	3/16	3/16	3/16	7/32	7/32	1/4	1/4	1/4	13/32	13/32	7/16
H	3/16	3/16	3/16	3/16	3/16	3/16	3/16	7/32	7/32	7/32	1/4	1/4	1/4	13/32	7/16
J	3/16	3/16	3/16	3/16	3/16	3/16	3/16	7/32	7/32	1/4	1/4	1/4	9/32	9/32	5/16
K	3/16	3/16	3/16	3/16	3/16	3/16	3/16	7/32	7/32	7/32	1/4	1/4	1/4	9/32	5/16
L	3/16	3/16	3/16	3/16	3/16	3/16	3/16	7/32	7/32	7/32	1/4	1/4	1/4	5/16	5/16
M	3/16	3/16	3/16	3/16	3/16	3/16	3/16	7/32	7/32	7/32	1/4	1/4	1/4	9/32	5/16
88% (D=0.614 T + 0.011")			3/16	7/32	1/4	9/32	11/32	3/8	13/32	7/16	1/2	17/32	9/16	19/32	5/8
N			1/4	1/4	1/4	9/32	5/16	3/8	13/32	7/16	1/2	17/32	9/16	19/32	21/32
75% (D=0.524 T + 0.022")			3/16	3/16	7/32	9/32	5/16	11/32	3/8	13/32	7/16	15/32	1/2	17/32	9/16
O			1/4	1/4	1/4	1/4	5/16	11/32	3/8	13/32	7/16	15/32	1/2	17/32	9/16
60% (D=0.419 T + 0.035")			3/16	3/16	7/32	7/32	1/4	9/32	5/16	11/32	3/8	13/32	13/32	7/16	15/32
P			1/4	1/4	1/4	1/4	1/4	5/16	11/32	3/8	13/32	7/16	7/16	1/2	17/32
Q			1/4	1/4	1/4	1/4	1/4	9/32	5/16	5/16	11/32	3/8	13/32	7/16	15/32
45% (D=0.314 T + 0.047")			3/16	3/16	3/16	3/16	7/32	1/4	1/4	9/32	5/16	5/16	11/32	11/32	3/8
R			1/4	1/4	1/4	1/4	1/4	1/4	9/32	5/16	5/16	5/16	5/16	11/32	3/8

4. DIRECT CALCULATION OF WELD SIZES

In Section 2 of this report, it has been shown that it is not possible to develop a single design strength equation which will uniformly handle the different combinations of ABS steels and electrodes. Therefore, it is not possible to use nominal design weld stresses unless such stresses are varied for each material and electrode combination or excessively large factors of safety are used. However, the calculations in Section 2 show that the ratio of 100% efficient weld sizes to plate thickness does not vary widely (only from 0.607 to 0.698) for typical ABS steels and electrodes. This ratio can form the basis of a procedure to base the weld sizes on direct calculations. Basically the procedure is to calculate a required local plate thickness at the joint which would sustain the nominal design stresses specified, multiply by 0.698 (or 0.628 for mild steel intercostal members, or one of the other values in column 4 of Table 4 if the electrode to be used is known) and add 1.414 times the corrosion allowance as appropriate:

$$D = 0.698 \times T_r + 0.085" \quad (17)$$

The main caution here is that the nominal design stresses specified must be based on strength and not on stiffness considerations such as buckling.

Another important caution is for end connections, particularly unbracketed end connections which are backed up as discussed in Section 5.1 or any member which is part of longitudinal strength structure or essentially continuous transverse structure. Nondimensionalized test results for a compact beam (i.e., no buckling imminent) simulating such a fillet welded, unbracketed, end connection are shown in Figure 14. If the test results of Figure 14 are plotted versus joint efficiency as shown in Figure 15, the load plots as a straight line because the joint efficiency is defined as a direct function of the load capacity. However, if the energy absorbed by the test beam (i.e., the area under the load deflection curve) is plotted versus joint efficiency as in Figure 15, the situation is drastically altered. For example, although a 75% efficient joint would develop 75% of the maximum load, it would develop only about 15% of the beam's energy capacity. Although there are probably very few merchant ship framing systems which need be designed to absorb significant amounts of energy in the plastic range, it would appear prudent not to reduce the strength of such end connections below the values specified in Appendix D.

If the joint in question must be designed for a combined loading, then the required thickness, T_r , must reflect the combined loading using an appropriate "failure theory". The assumption in this procedure is that the fillet welds

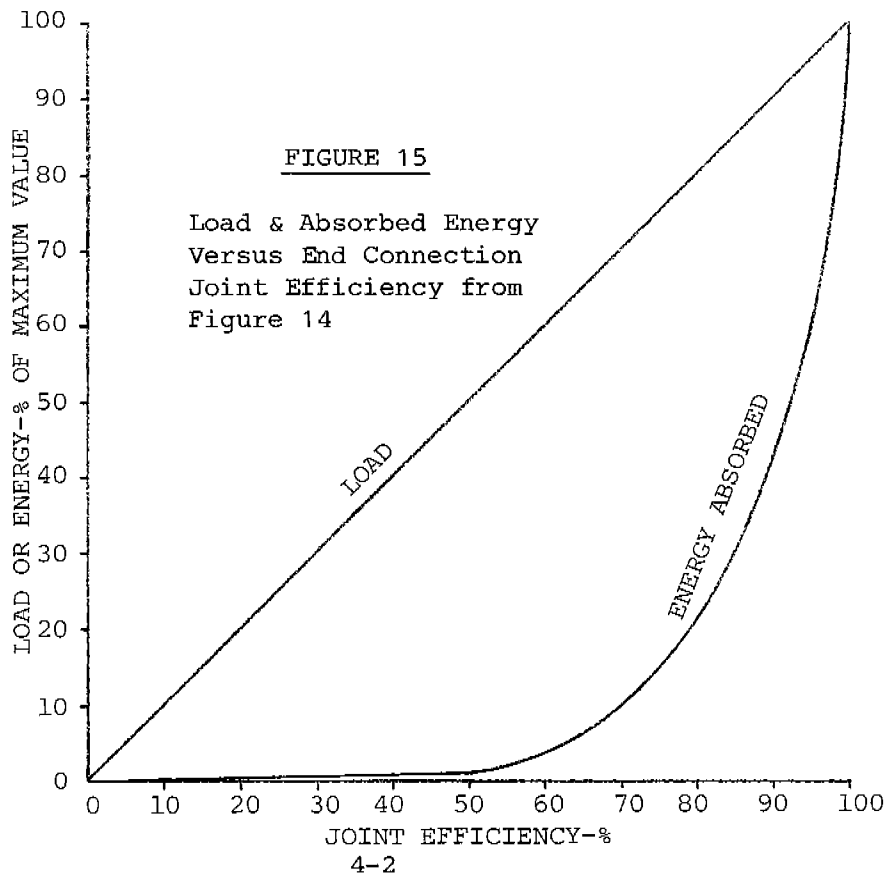
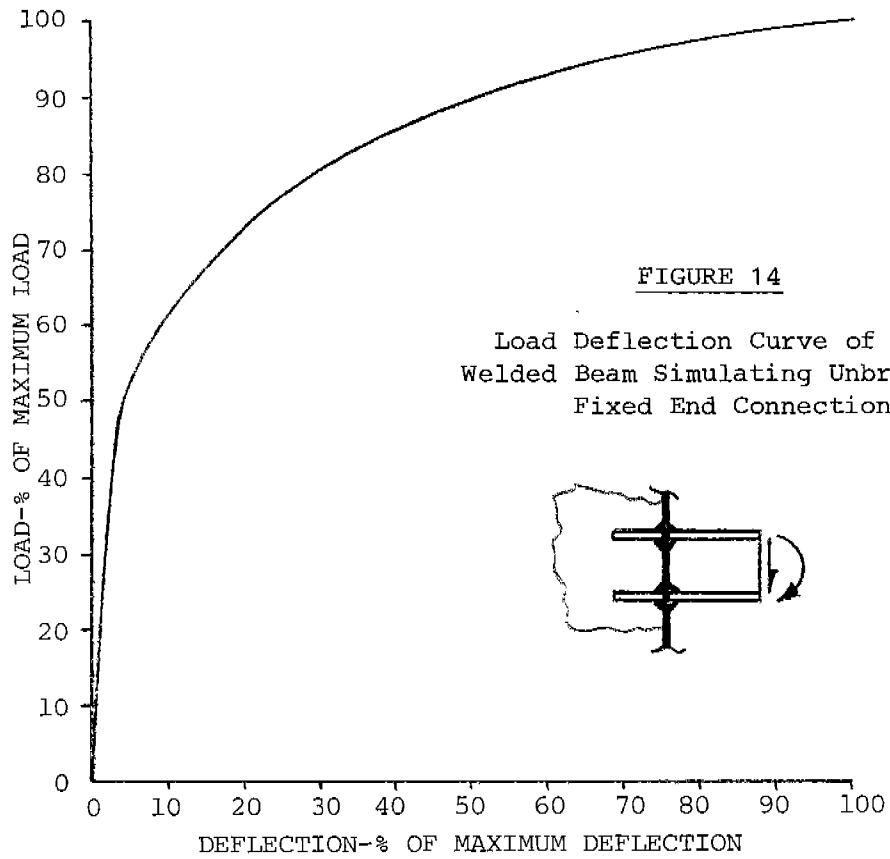

5. USE OF PROPOSED DESIGN CRITERIA

With any welding design procedure, several additional questions besides the required weld efficiency must be answered. These questions include what plate to base the weld on, how to handle unusual cases, how unbalanced the welds can be, what construction tolerances are appropriate, what minimum weld sizes to use, when to use intermittent welding, and how to handle special protective coatings? These questions will be discussed in this section.

5.1 Tee Type Joints

When applying this proposed double fillet weld design criteria, it is intended that the weld size for tee type joints will generally be based on the thickness of the intercostal or non-continuous member of the joint. This is to avoid the complex problem of determining which member is really the weaker. The current Navy procedure for determining the "weaker" member is to choose the member with the lowest product of thickness times ultimate tensile strength [see Section 11.3.4.1 of Reference 3] while the current ABS procedure is to use the "lesser thickness of members joined" (see column headings in Appendix A) except in special cases (see Note 1 to weld table in Appendix A). However, from the discussions in Section 2.1 of this report, it should be evident that neither procedure is entirely correct and that the determination of which member is the weaker is also a function of loading direction. For example, in Figure 1 the product of thickness and shear strength of the intercostal member should be compared to twice the product of thickness and shear strength of the continuous member, whereas in Figure 2 the product of thickness and tensile strength of the intercostal member should be compared to twice the product of thickness and shear strength of the continuous member. For most cases the intercostal member will thus be the weaker member.

Another case which should also be considered is the quite common joint shown in Figure 16. Here a relatively thin plate is continuous through a heavier one, for example a deck or longitudinal stiffener in way of a transverse bulkhead. In this case, the intercostal member is "backed up" and the weld should be based on the thickness of the intercostal member. The thickness of the continuous member has no influence on the required weld strength in this case.

Therefore, it appears that basing the weld sizes on the thickness of the intercostal member for tee type joints is more consistent and will generally result in a more optimally welded structure. It also has the advantage of being a simpler rule to use than the ABS or particularly the Navy procedure.

For cases where this procedure of using the intercostal member may give excessively large welds, several alternatives are available. First, if the continuous member is really the weak link in the connection, then an effective intercostal member thickness could be determined by considering the shear and

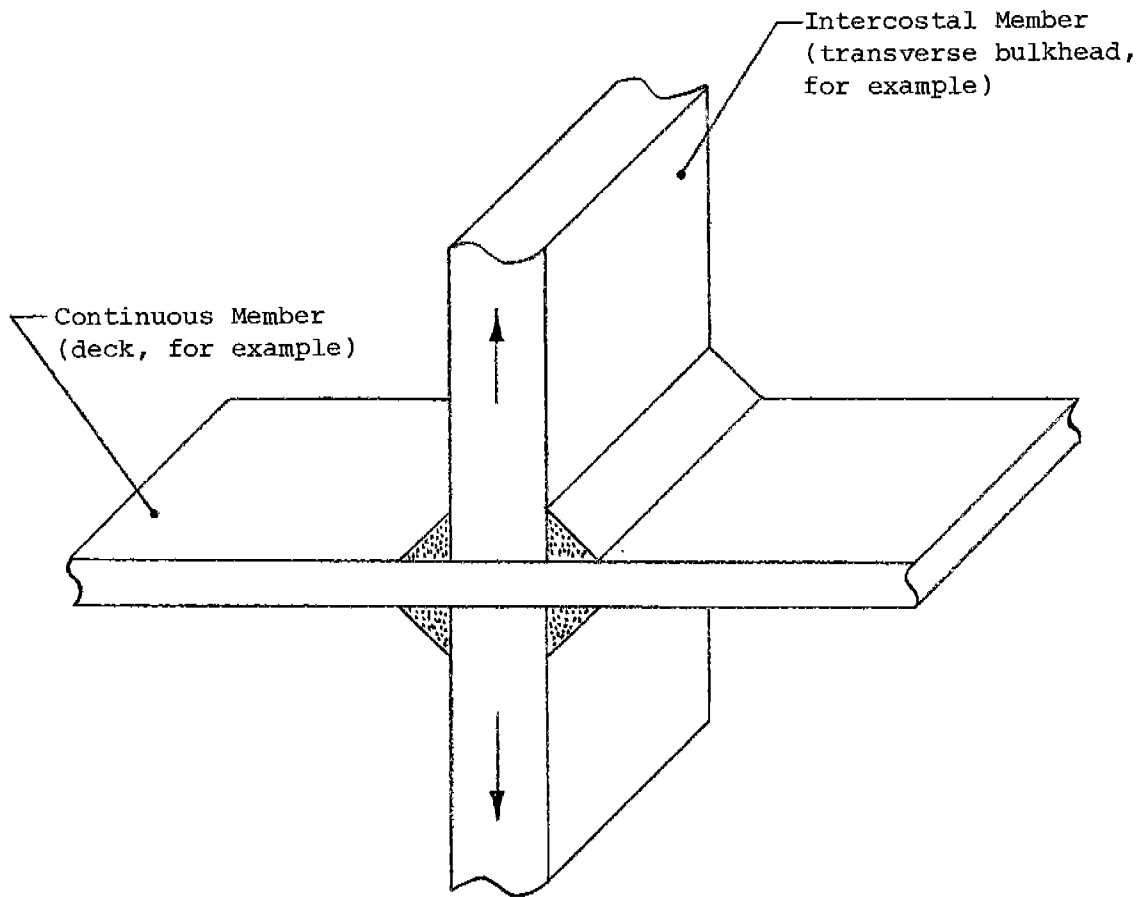

FIGURE 16

Double Fillet Weld In Way of a "Backed Up" Member

tensile strengths of the two members as described above and the weld based on that effective thickness. Second, the joint could be designed for the loads it must carry using the procedures described in Section 4.

5.2 Lap Joints and Corner Type Joints

For lap joints, the Navy procedure is clearly the best procedure to use. That is, the weld should be based on the thickness of the member with the lowest product of thickness times ultimate tensile strength since there is only a single failure plane in each of the joined members to be concerned with, although all six failure modes are still considered.

Corner type joints made with fillet welds are similar in principle to lap type joints: there is only a single failure plane in each of the joined members to be concerned with. Two corner type joints are shown in Figures 17 and 18. For longitudinal shear loading, which should cover the majority of corner joints, using the weaker member as defined by the Navy is clearly adequate. However, for transverse shear loading, the tensile strength of one member should be compared to the shear strength of the other when determining the weaker member. Although this is another complication, it could be considered if necessary.

5.3 Slightly Unbalanced Welds

In Table 8 both the existing and the proposed weld sizes are given in increments of 1/32 inch which is a bit finer than many shipyards work with. Increments of 1/16 inch are commonly used to reduce the number of fillet weld size gages and to simplify inspections. An alternate approach which has been used previously to reduce the amount of weld while still minimizing the number of weld sizes is shown in Figure 19. Whenever the tabular size is in 32nds, the fillet on one side of the weld is rounded up and the fillet on the other side is rounded down to the nearest 16th. This results in a slightly unbalanced joint as shown in Figure 19. For reasonably long joints loaded in longitudinal shear as shown in Figure 1, this slight unbalance should be completely insignificant. For welds loaded in transverse shear as shown in Figure 2, the slight unbalance would have a greater effect than the longitudinal shear case but it still should not be significant. It should be noted that two special cases in the current ABS rule tables, lines 56B and 72B, permit much larger variations in strengths on opposite sides of the connection. These two cases require continuous welds on one side of the connection with intermittent welds of much lower efficiency on the opposite side of the connection (see plots for ABS Weld Groups C1 and C2 in Appendix C). Therefore, it is felt that the current practice of allowing these slightly unbalanced joints should continue.

5.4 Construction Tolerances

This study is primarily concerned with minimum design weld sizes which are those commonly specified on working drawings. Construction tolerances are generally covered by other fabrication documents such as detail welding

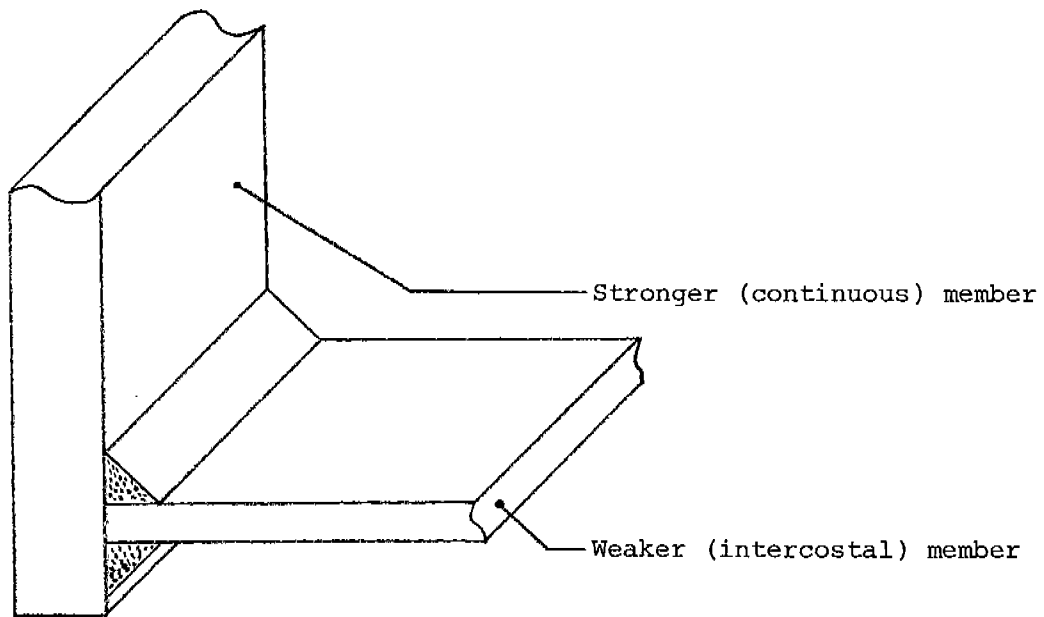

FIGURE 17

Double Fillet Weld In Way of a Corner Joint - Case 1

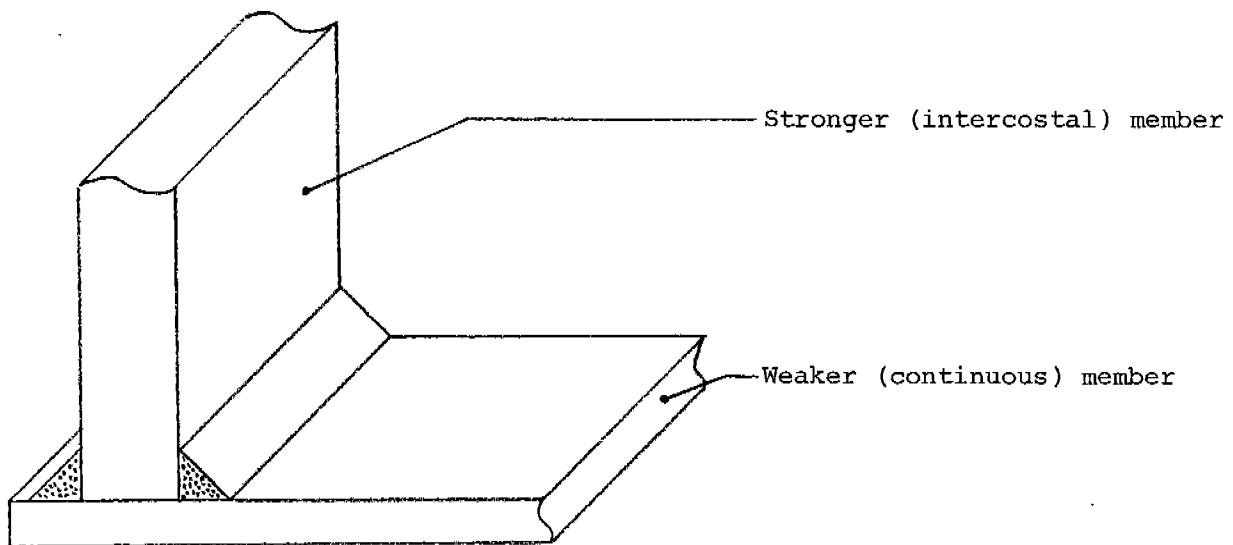
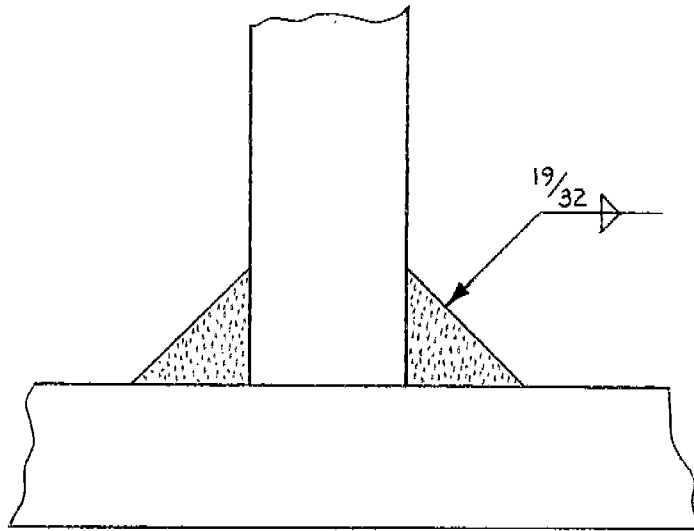
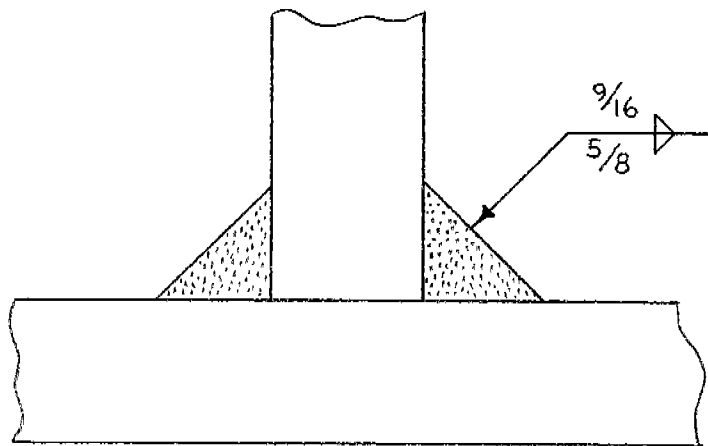

FIGURE 18

Double Fillet Weld In Way of a Corner Joint - Case 2



(a) Tabular Weld



(b) Actual Weld

FIGURE 19

Example of a Slightly Unbalanced Fillet Weld

procedures and are thus beyond the scope of the present study. However, one construction tolerance, the allowable opening between the plates before welding (i.e., the root gap), should be discussed here.

The current ABS allowance [Section 30.9.1 of Reference 2] for root gap is: "Where the gap between faying surfaces of members exceeds 2.0 mm or 1/16 in. and is not greater than 5 mm (3/16 in.) the weld leg size is to be increased by the amount of the opening." By comparison, the current military standard [Note 1 of Figure 22 of Reference 11] is: "Where (the root gap) is greater than 1/16 inch as a nominal condition, (the fillet size) shall be increased by an amount equal to the excess of the opening above 1/16 inch." The military standard also specifies the 3/16 inch maximum root opening. Some Japanese tests [see pages 9-126 and 9-127 of Reference 12] have indicated that root openings of up to 1/8 inch contribute to deeper penetration and consequently increase the strength of the weld. In view of these tests, it would appear appropriate to revise the current ABS root gap allowance to the slightly less conservative military standard.

5.5 Minimum Weld Sizes

When discussing minimum weld sizes it is important to distinguish between design values and as-built sizes. The minimum weld size generally produced by normal shipyard structural welding processes is about 3/16 inch. However, it is advantageous to specify design weld sizes on the working drawings as small as 1/8 inch where feasible for several reasons. First, as stated in Section 3.3 of Reference 1, "It is a common attitude for an inspector to reject . . . slightly undersized fillet welds." Unless the working drawings show the minimum weld size that is structurally acceptable rather than a somewhat arbitrary minimum value, the inspector has no practical alternative to rejecting all welds which fall below the arbitrary minimums. Second, the construction tolerances discussed in Section 5.4 require an increase in the weld sizes specified on the working drawings if the root opening is excessive. This increase will be applied to whatever weld size is specified on the working drawings which could result in excessive welding if arbitrary minimum values are used.

The existing ABS weld tables specify a minimum fillet weld size of 1/4 inch in the cargo tanks and ballast tanks in the cargo area for vessels classed as "oil carrier" and 3/16 inch (or 11/64) for other locations and vessels. For naval ships, 1/8 inch has generally been used as the minimum design fillet weld size [see Section 11 of References 3, 4, and 5 or Figures 1 through 40 of Reference 6]. It should be noted that this 1/8 inch minimum size has been used, apparently successfully, with the more liberal than ABS root opening allowance discussed in Section 5.4 and no corrosion allowance. Thus, it would appear that the ABS minimum fillet weld sizes can and should be reduced. As a concession to the "oil carrier" category, it is proposed that the ABS minimum weld sizes be reduced by 1/16 inch to 3/16 inch in the cargo tanks and ballast tanks in the cargo area for vessels classed as "oil carrier" and 1/8 inch for other locations and vessels. As can be readily determined from Figure D-6 for

mild steel structures, this proposed 1/16 inch reduction would generally involve only plates less than 0.84 inches thick for oil carriers and 0.51 inches thick for other vessels. For higher strength steel structures, Figure D-2 gives plates less than 0.76 inches thick for oil carriers and 0.47 inches thick for other vessels which would be affected by the proposed reduction.

The minimum weld size should also be a function of plate thickness to avoid the possibility of weld cracking due to insufficient heat input. In Section 30.9.1 of the ABS Rules, this problem is identified: "Special precautions such as the use of preheat or low-hydrogen electrodes or low-hydrogen welding processes may be required where small fillets are used to attach heavy plates or sections." As stated in Reference 13, "clearly any increase in preheat required by an increased chance of cracking could offset the economic benefits to be obtained from a reduction in fillet size." The weld sizes of the 30% efficiency category provide a reasonable approximation to the minimum weld sizes proposed in Reference 13 and Section 2.7.1.1 of the American Welding Society code [Reference 14], as shown in Figure 20. Consequently, if the weld sizes are based on direct calculations, no reductions below the 30% efficiency curve are proposed.

To further explore minimum weld sizes, design calculations have been prepared to check the required strength of the connection of bottom longitudinals to shell plate for the three sample ships. These connections should be among the most highly loaded fillet welded joints in the 30% efficiency category on the ships. The results of these calculations are summarized in Figure 21. As discussed in Appendix E, the calculation using von Mises combined stresses seems excessively conservative and, in fact, gives weld sizes greater than those required by ABS weld group M4. Modifying the von Mises equation to more accurately reflect experimental ultimate shear to ultimate tensile strength ratios (74.5% versus 57.7% in the original von Mises equation) produces more reasonable weld sizes. The simplified analyses are more in line with ABS nominal strength analysis procedures and give results which support the proposed reductions in ABS minimum weld sizes. All the calculations include a corrosion allowance. The end effects correction is due to a portion of the load acting on the shell plate being transferred directly to the floors rather than through the longitudinals and then into the floors. This correction is especially important on the containership and the O/B/O because their solid floors are spaced at intervals of less than two longitudinal frame spaces (i.e., bottom shell panel aspect ratios of 1.68 and 1.50 respectively).

5.6 Intermittent Versus Continuous Welding

The use of continuous welding or intermittent welding where permitted by the ABS rules is essentially an economic trade-off because, with proper attention to details near the ends of the member, intermittent welds can be as strong as continuous welds. Intermittent welds do have an advantage on very thin structures where the minimum feasible continuous welds would give excessively strong joints. Chapter XIII of Reference 15 presents an analysis of essentially minimum size welds giving comparative costs of \$1.83 for

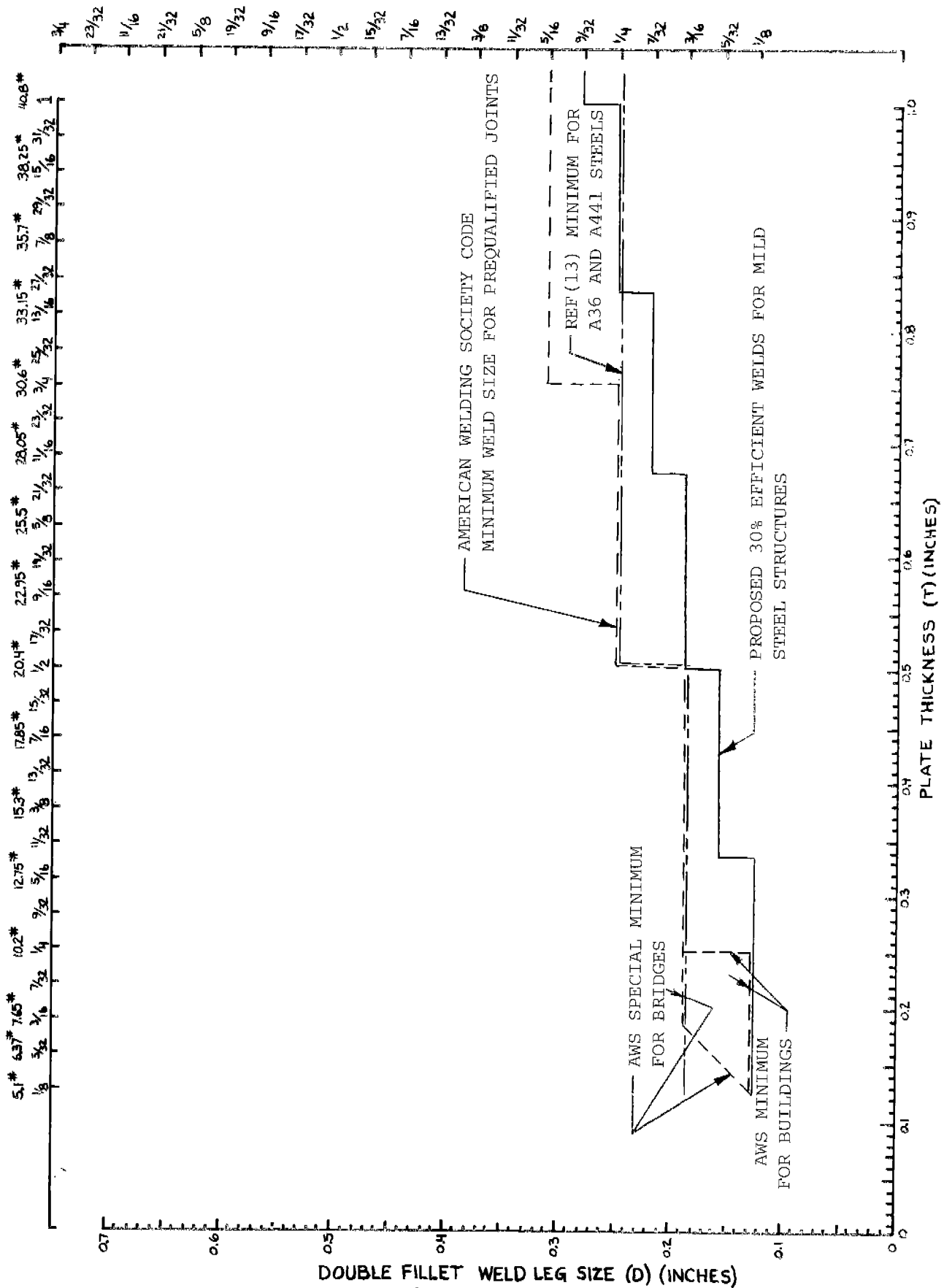

FIGURE 20

COMPARISON OF AWS, REFERENCE 13, AND PROPOSED MINIMUM WELD SIZES

486-330



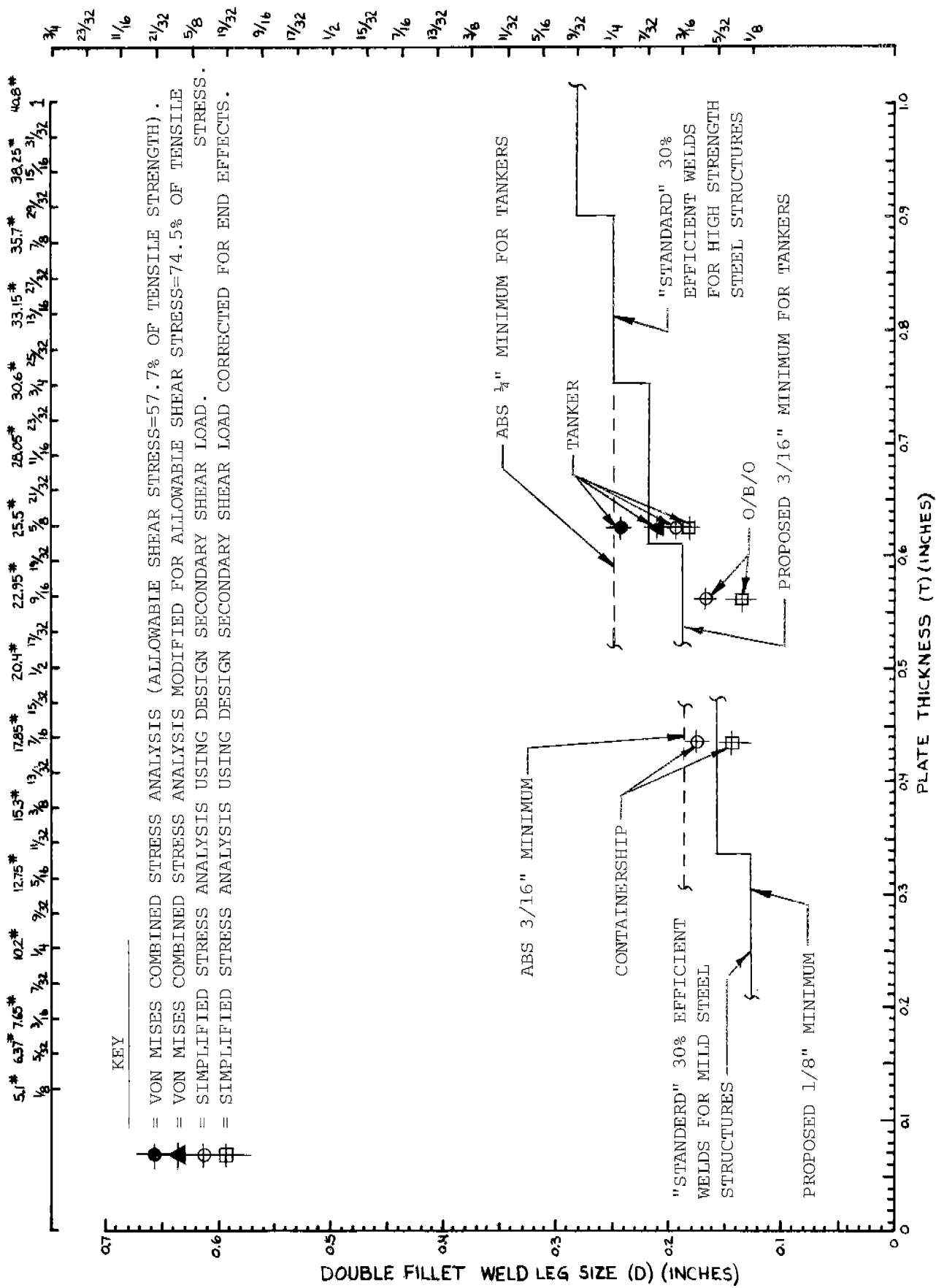

FIGURE 21

COMPARISON OF SAMPLE SHIP CALCULATED AND PROPOSED TABULAR WELD SIZES FOR CONNECTION OF BOTTOM LONGITUDINALS TO SHELL PLATE

486-330



continuous automatic welding, \$2.80 for intermittent manual welding, and \$6.43 for continuous manual welding. The continuous weld sizes were 5/32" while the intermittent welds were 3/16" 3-12. To compare equal strength joints the 5/32" continuous welds should be compared to 3/16" 10-12 intermittent welds if no corrosion allowance is involved or to 3/16" 8-3/8 - 12 intermittent welds if a corrosion allowance of 0.060" per surface is considered using equations (15) and (16) respectively. This should increase the cost of the intermittent welds considerably.

Since facilities will vary and the location of the joint when it is to be welded must be considered, this type of trade-off is best left to each individual shipyard.

5.7 Special Protective Coatings

In various sections of the ABS rules, a reduction in scantlings is permitted if specially approved protective coatings are applied to the structure or other effective methods are adopted as a means of corrosion control. The required weld sizes are thus reduced because they are based on the reduced scantlings. However, this presents a slight inconsistency because the weld tables still include a corrosion allowance. It would appear more appropriate to use a different set of weld tables with the corrosion allowance removed for this case. This can easily be done using equation (13) rather than equation (14). The major question would be whether or not the joint efficiencies used with equation (14) would still be suitable for use with equation (13). It would seem hard to argue against using the same efficiencies. That is, if a joint efficiency of say 30% after the structure has been corroded in a severe environment is acceptable, then why shouldn't the same efficiency be acceptable in a protected environment. The amount of weld size reduction obtainable by this procedure (aside from that already obtained by the reduced scantlings) can be seen by comparing corresponding curves in Figures 9 and 11. Neglecting differences due to rounding off to standard weld sizes, the maximum reduction would vary from 0.001" for 100% efficient joints to 0.060" for 30% efficient joints. For the mild steel only case in Table D-6 of Appendix D, the maximum reduction would vary from 0.010" for 100% efficient joints to 0.062" for 30% efficient joints. However, some adjustment may be required for the smaller weld sizes to avoid the cracking problem from insufficient heat input mentioned in Section 5.5.

6. APPLICATION OF PROPOSED DESIGN CRITERIA TO SAMPLE SHIPS

The proposed fillet weld design criteria has been applied to three sample ships to give a practical comparison with the existing ABS Rules and to allow an economic assessment of the proposal to be made. The following sections summarize that work, much of which is included in Appendices E, F, and G.

6.1 General Procedure

The three sample commercial ships have been selected from the Maritime Administration CMX Designs [Reference 16]. Principal Characteristics of the three ships are given in Table 9. Arrangement drawings, scantling drawings, and characteristics at scantling drafts can be found in Appendices E, F, and G.

<u>TABLE 9</u>				
Principal Characteristics of Sample Ships				
<u>Dimension</u>	<u>Voyager Class Tanker</u>	<u>Vanguard Class Containership</u>	<u>Crescent Class Ore/Bulk/Oil Carrier</u>	<u>Units</u>
Length overall	950-0	725-0	871-0	ft-in.
Length between perpendiculars	900-0	685-0	827-0	ft-in.
Beam	147-6	103-0	106-0	ft-in.
Depth at side	63-6	60-0	60-0	ft-in.
Design draft	48-6	29-6	42-6	ft-in.
Displacement at design draft	147,400	32,200	86,700	long tons
Deadweight at design draft	125,200	19,700	69,300	long tons
Steel weight	18,909	9,125	14,378	long tons
Outfitting weight	1,467	1,853	1,499	long tons
Machinery weight	1,091	1,112	932	long tons
Margin	733	410	591	long tons

The midship section of each ship was first checked for compliance with the 1981 ABS Rules. This allowed slight reductions in the existing scantlings which had been sized to the 1970 ABS Rules. Weld sizes required by the 1981 ABS Rules and the proposed design criteria were then determined. After additional calculations were performed for a few critical welds, tabulations of weld sizes, lengths, and weights were made including estimates for bow, stern, and deckhouse structures. These values were then used in the economic analysis.

6.2 Voyager Class Tanker

Table 10 summarizes the data developed for the tanker, a detail listing of which can be found in Appendix E. It should be noted that, as on the other two sample ships, the weighted average weld size is fairly small. About 2,700 feet (1%) of the altered weld length is increased rather than decreased in size by the proposed design procedure.

<u>TABLE 10</u>					
<u>Summary of Lengths, Sizes, and Weights of Welds</u>					
<u>for Voyager Class Tanker</u>					
	Total Length of Double Fillet Welds (Feet)	Average Design Weld Size (Inches)		Weight of Design Welds (Pounds)	
		Existing	Proposed	Existing	Proposed
Altered Welds	342,210	0.268	0.225	83,500	59,095
Unaltered Welds	48,918	0.338	0.338	18,998	18,998
TOTALS	391,128	0.278	0.242	102,498	78,093

The bottom longitudinals of this ship were analyzed in some detail using ABS Rule loadings and the principles discussed in Section 4. Since these members are built up "T" beams, both the web to flange and the web to bottom shell plating connections were checked. Interestingly enough, an analysis using the von Mises yield criteria gives weld sizes greater than those required by the current ABS Rule weld Tables. Modifying the von Mises equation to more accurately reflect experimental ultimate shear to ultimate tensile strength ratios (74.5% versus 57.7% in the original von Mises equation) produces more reasonable weld sizes. Fortunately, the Bulk Oil Carrier Section of the ABS Rules gives sufficient data to allow calculation of nominal design stresses for the structural members and thus allow a nominal design stress analysis of the welds. The latter analysis gives reasonable weld sizes as shown in Figure E-5 of Appendix E.

Additional calculations were performed to check the strength of the connection of bottom longitudinals to bottom transverses and the connection of deck longitudinals to deck transverses.

6.3 Vanguard Class Containership

Table 11 summarizes the data developed for the containership. For this ship, additional calculations were made for the connection of longitudinals to bottom shell and for the connection of bottom longitudinals to web frames. About 1,400 feet (1%) of the altered weld length is increased rather than decreased in size by the proposed design procedure.

<u>TABLE 11</u>					
<u>SUMMARY OF LENGTHS SIZES AND WEIGHTS OF WELDS</u>					
<u>FOR VANGUARD CLASS CONTAINERSHIP</u>					
	Total Length of Double Fillet Welds (Feet)	Average Design Weld Size (Inches)		Weight of Design Welds (Pounds)	
		Existing	Proposed	Existing	Proposed
Altered Welds	191,667	0.232	0.204	35,116	27,061
Unaltered Welds	62,058	0.271	0.271	15,506	15,506
TOTALS	253,725	0.242	0.222	50,622	42,567

6.4 Crescent Class Ore/Bulk/Oil Carrier

Table 12 summarizes the data developed for the Ore/Bulk/Oil Carrier. For this ship, the thickness of the deck slab longitudinals is slightly greater than the maximum value for which a weld size is specified in the ABS Rules. Hence, the next larger size is used. The appropriate equation for 30% efficient welds gives the same size. Additional calculations were prepared for the connection of longitudinals to the bottom shell. About 18,000 feet (8%) of the altered weld length is increased rather than decreased in size by the proposed design procedure. Most of these increases are in the bottom structure which apparently was not optimized to the same extent as the other two sample ships.

<u>TABLE 12</u>					
<u>Summary of Lengths, Sizes, and Weights of Welds for Crescent Class Ore/Bulk/Oil Carrier</u>					
	Total Length of Double Fillet Welds (Feet)	Average Design Weld Sizes (Inches)		Weight of Design Welds (Pounds)	
		Existing	Proposed	Existing	Proposed
Altered Welds	213,909	0.277	0.239	55,784	41,503
Unaltered Welds	66,793	0.336	0.336	25,631	25,631
TOTALS	280,702	0.292	0.265	81,415	67,134

6.5 Fillet Weld Comparisons

Table 13 compares lengths, size reductions, and weight reductions for the three sample ships. Approximately 75 to 87 percent of the weld length on these ships could be reduced an average of 8 to 13 percent in size by using the proposed design criteria.

<u>TABLE 13</u>			
<u>Double Fillet Weld Comparisons for Sample Ships</u>			
	Voyager Class Tanker	Vanguard Class Containership	Crescent Class Ore/Bulk/Oil Carrier
Length of altered welds (feet)	342,210 (87.5%)	191,667 (75.5%)	213,909 (76.2%)
Reduction in Average weld size (inches)	0.036 (12.9%)	0.020 (8.3%)	0.027 (9.2%)
Reduction in weight of fillet welds (long tons)	10.9 (23.8%)	3.60 (15.9%)	6.38 (17.5%)
Length of welds in 30% efficiency category (feet)	262,145 (67.0%)	182,727 (72.0%)	197,739 (70.4%)

Figures 22 and 23 compare the lengths and weights of the proposed fillet welds versus weld efficiency category for the three sample ships. It should be noted that only a small percentage of fillet welds for typical commercial ships is required to develop the full strength of the joined members (i.e., 100% efficient welds). The majority of fillet welds (approximately 70% of weld length and 50% of weld weight) fall in the 30% efficiency category. As discussed in Section 5.5, the 30% efficiency category represents minimum practical weld sizes for a shipyard production environment. Thus it would appear that the proposed design criteria has accounted for most of the significant, practical ABS fillet weld size reductions.

The differences in lengths and weights of welds in the 45, 60, 75, and 88% efficiency categories are not significant. The 88% efficiency category is unique to single-hull bulk oil carriers. The amount of weld in the other categories will vary with the length of watertight boundaries and with the amount of bracketed versus unbracketed stiffener and girder end connections on a particular ship.

6.6 Cost Saving Estimates

Cost estimates can be prepared to many different degrees of refinement depending on the resources available and the expected use of the estimates. For the purposes of this study, only an order of magnitude estimate of cost savings was specified. Consequently, very simple estimating procedures have been used. However, sufficient data on the three sample ships is provided in Tables 10 through 13 and Appendices E, F, and G to allow an independent investigator to prepare additional cost estimates to any degree of refinement desired.

For a simplified cost estimate, some relationship between weld size and cost is required which reflects the many different welding processes, steel combinations, and electrodes used in a typical shipyard. Intuitively, one would expect the cost of fillet welding to vary as a function somewhere between the weld size and the weld cross-sectional area (i.e., the deposited weld metal). A reasonable relationship for the purposes of this study is given in equation (18) where RC is the cost of a given fillet weld of size D in inches expressed as a percentage of the cost of 5/8 inch fillet welds.

$$RC = 15 + 223.45 (D - 0.125)^{1.5} \quad (18)$$

Figure 24 shows this curve along with the expected limits of any reasonable fillet weld cost curve. Also shown on Figure 24 are data points from a series of laboratory studies. Each data point represents an unweighted average of three weld positions (flat or horizontal, vertical, and overhead) for two combinations of material (HTS and HY80) with five electrodes for shielded metal arc welding (7015/7016, 7018, 8018, 9018, and 11018) and two electrodes for gas metal arc welding (70S-3 and 100S-1). Thus each data point is generally an average of 27 experimental points. These data are also plotted in Figure 25 in the form of the original test series with equation (18) modified to suit each test series. Equation (18) fits the experimental data very well

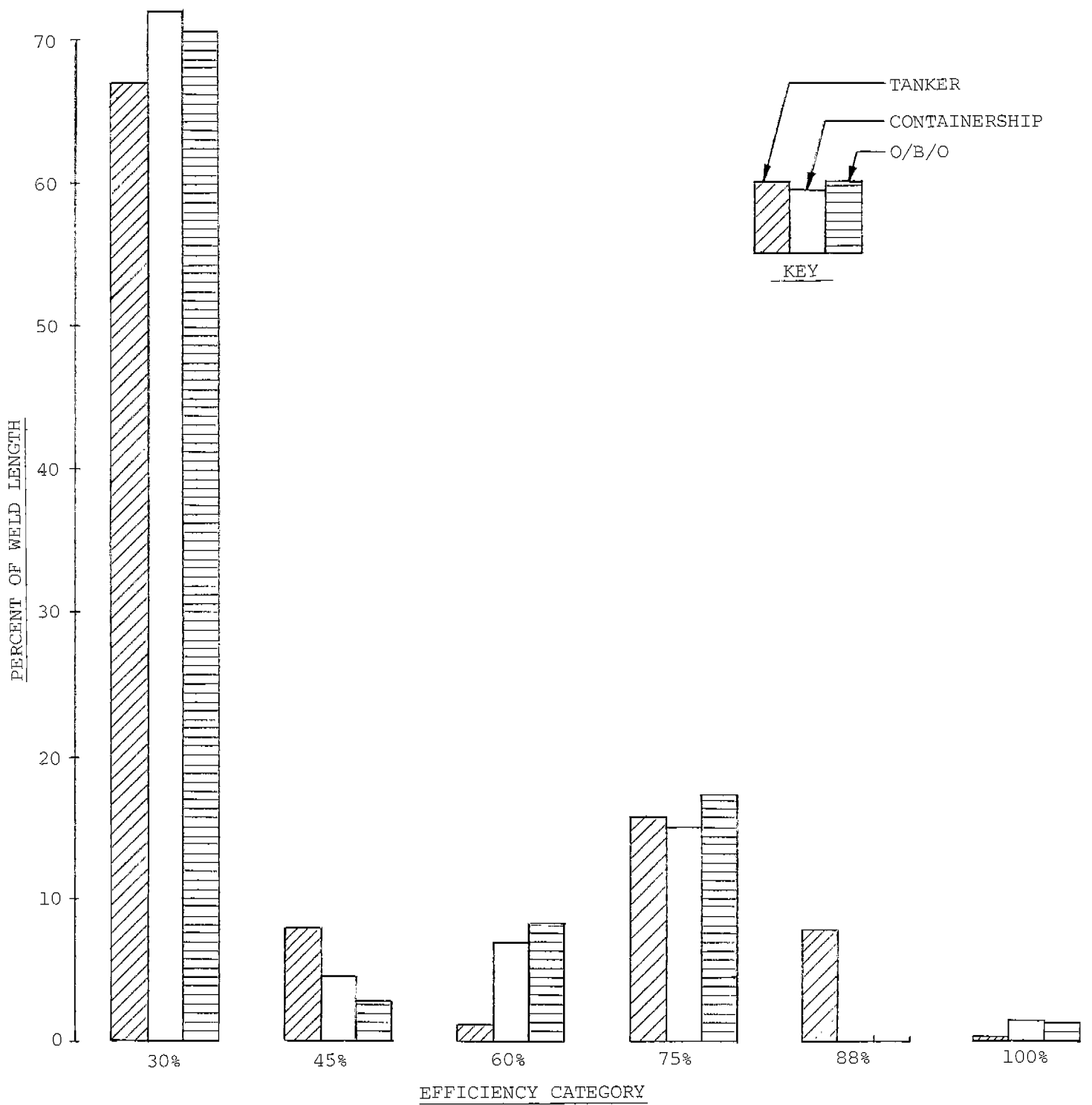

FIGURE 22

WELD LENGTH VERSUS EFFICIENCY CATEGORY FOR SAMPLE SHIPS

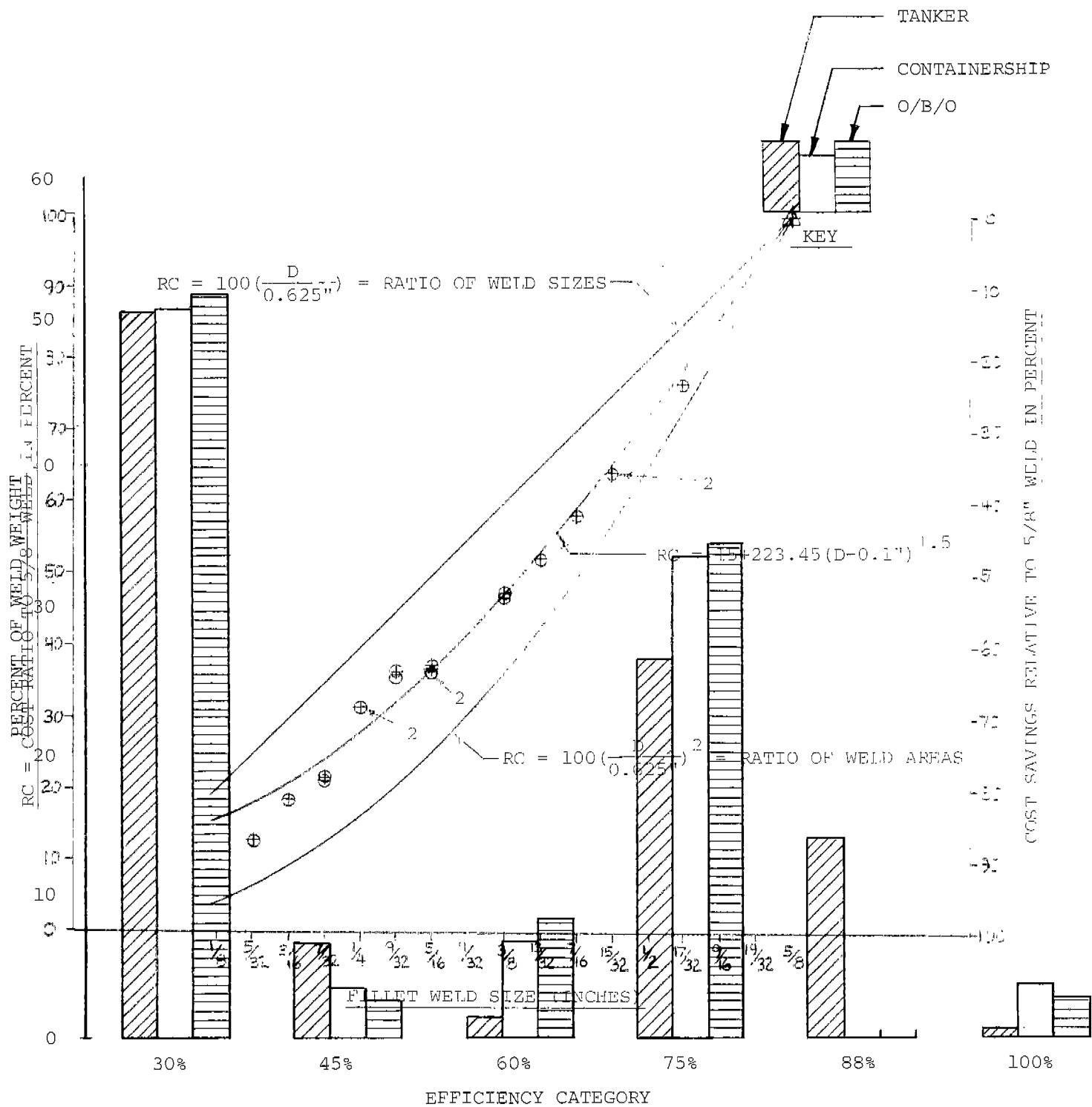

FIGURE 23

WELD WEIGHT VERSUS EFFICIENCY CATEGORY FOR SAMPLE SHIPS

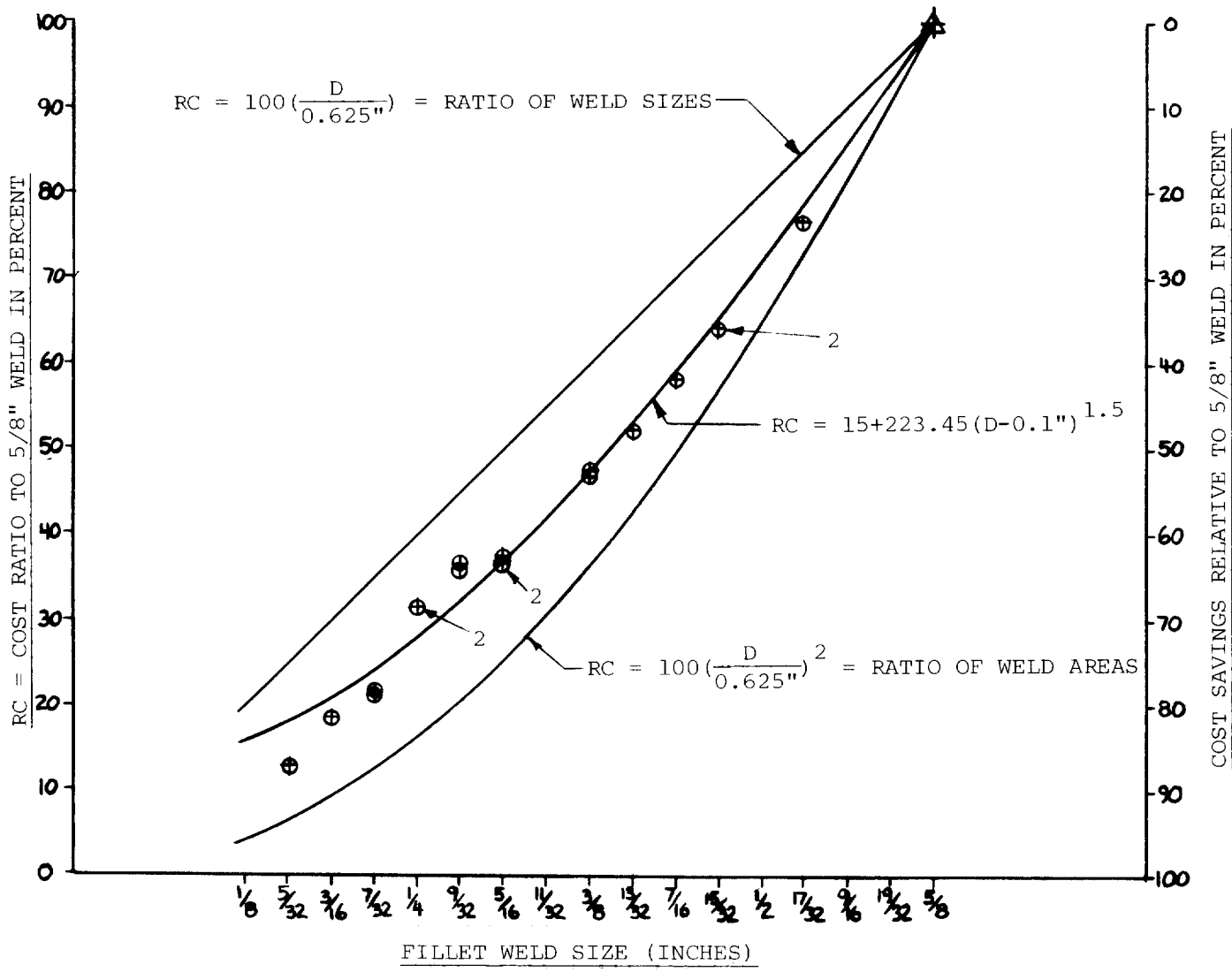

FIGURE 24
FILLET WELD RELATIVE COST CURVES

486-330 - (62)

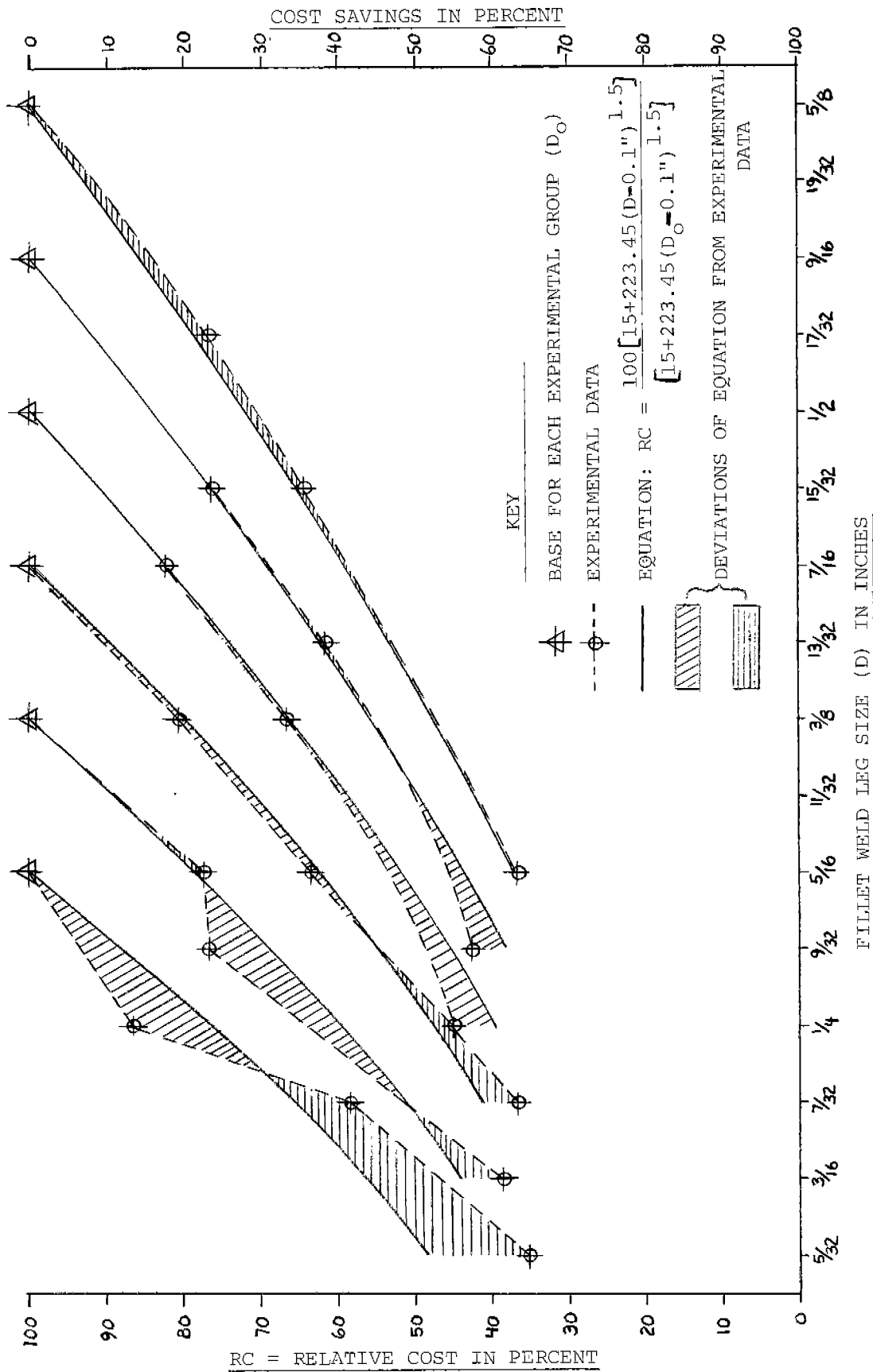

FIGURE 25

FILLET WELD RELATIVE COST CURVES FOR TEST SERIES

486-330



in the larger weld sizes and effectively averages the data for smaller weld sizes as required for this study.

The only additional data needed to make a reasonable cost estimate for the sample ships is a base weld cost. For this study it will be assumed that the average cost of 1/4 inch double fillet welds is \$3.00/foot in spring 1982 dollars. It is assumed that this value includes material, labor, and overhead. Equation (18) gives a relative cost of 27.98% for 1/4 inch fillets. Using these values the cost savings for each of three sample ships is shown in Table 14. The dollar amounts vary from 66,300 to 203,00 per ship while the percentage savings vary from 9.0 to 15.2.

TABLE 14			
Fillet Weld Cost Savings for Sample Ships Using Derived Cost Curve and \$3.00/Foot for 1/4 Inch Double Fillet Welds			
Item	Voyager Class Tanker	Vanguard Class Containership	Crescent Class Ore/Bulk/Oil Carrier
A = Length of Double Fillet Welds (feet)	391,128	253,725	280,702
D ₁ = Existing Average Fillet Weld Size (inches)	0.278	0.242	0.292
F ₁ = Cost/Ft of Existing Welds = $\frac{\$3.00/\text{Ft}}{27.98\%} \times [15+223.45(D_1 - 0.1")^{1.5}]$	3.408	2.890	3.624
K ₁ = Cost of Existing Fillet welds = A x F ₁	\$1,333,000	\$ 733,300	\$1,017,000
D ₂ = Proposed Average Fillet Weld Size (inches)	0.242	0.222	0.265
F ₂ = Cost/Ft of Proposed Welds = $\frac{\$3.00/\text{Ft}}{27.98\%} \times [15+223.45(D_2 - 0.1")^{1.5}]$	2.890	2.629	3.214
K ₂ = Cost of Proposed Fillet Welds = A x F ₂	\$1,130,000	\$ 667,000	\$ 902,000
Cost Savings = K ₁ - K ₂	\$ 203,000	\$ 66,300	\$ 115,000
Cost Savings in Percent = $100(K_1 - K_2)/K_1$	15.2%	9.0%	11.3%

7. SUMMARY AND CONCLUSIONS

- 7.1 A new fillet weld design procedure has been developed for commercial ships which gives some modest reductions in weld size from the existing ABS Rule Tables along with some increases for consistency.
- 7.2 The weld size reductions are obtained by:
- o eliminating the inconsistencies in the current ABS Rule weld tables,
 - o varying the required weld size with material type, and
 - o reducing the minimum specified weld size.
- 7.3 The new weld size procedure has been put in a form suitable for design office use. It is much easier to use and to apply to unusual situations than the current ABS Rule tables.
- 7.4 The weighted average ABS fillet weld leg sizes for the three sample ships are already fairly small (0.242 to 0.292 inches). Thus the existing ABS fillet welds are, in general, not excessively conservative.
- 7.5 The majority of welds on the three sample ships (70% by length and 50% by weight) are minimum practical weld sizes for a shipyard production environment. Thus significant further reductions in ABS fillet weld sizes are not expected.
- 7.6 Weld cost savings in the order of 9 to 15 percent for three sample ships are obtainable with the proposed design procedure.
- 7.7 Additional fillet weld size reductions and cost savings could be obtained if a shipyard elected to use 8000 series in lieu of 7000 series electrodes on H32 and H36 material. Similar reductions could be obtained for the use of automatic welding processes on H32 and H36 material by using the bare electrode strength values of Figure 8 and the sizing procedure of Section 2. In both cases the resulting weld sizes would be equal to or slightly less than the values shown in Table D-6 which are designated for mild steel only.

8. RECOMMENDATIONS

- 8.1 The existing ABS Rules should be revised to incorporate the proposed design procedure (Appendix D of this report).
- 8.2 The existing ABS Rule allowance for excessive root gap should be revised to the current military standard value (see Section 5.4).
- 8.3 If further comparisons between ABS and other Rule weld sizes (such as Lloyds) are made, they should be extensive comparisons rather than sampling type comparisons such as those done in Reference 1. A major question would be the lack of an explicit corrosion allowance in some rules such as Lloyds or the U.S. Navy.
- 8.4 Consideration should be given to developing and incorporating into the existing ABS Rules weld tables without a corrosion allowance for use where specially approved protective coatings are applied to the structure or other effective methods are adopted as a means of corrosion control (see Section 5.7).
- 8.5 Future commercial ship fillet weld research should concentrate on verifying that the joint efficiencies shown in Appendix D are adequate for all commercial ship applications and on establishing additional line items for specific structural connections such as compensation for cuts in structure as mentioned in Section 3.3.
- 8.6 The weld sizing procedure of Section 2 should either be incorporated into the existing ABS Rules or referenced therein to help individual shipyards to readily determine appropriate weld sizes for the particular steels, electrodes, and welding processes they use.
- 8.7 Subsequent studies should include tests similar to those discussed in Section 5.4, where further verification is required to assess the strength of small fillet welds with various root openings. Additional studies on the damage frequency and durability of fillet welds could also be made.
- 8.8 Where 1/8 inch welds are not acceptable to ABS, an alternative to avoid excessive weld deposit increases for root gaps may be to change all 1/8 inch welds to 3/16* and add the following footnote to the weld tables:

Footnote:

Where 3/16* fillet welds are shown, the fillet size need only be increased by 1/16 inch for a 3/16 inch root gap (in lieu of the 1/8 inch required by the current military standard or 3/16 inch required by the current ABS procedure, see Section 5.4). For a 1/8-inch root gap, no weld size increase is required.

REFERENCES

1. Tsai, C. L.; Itoga, K.; Malliris, A. P.; McCabe, W. C.; and Masubuchi, K.; "Review of Fillet Weld Strength Parameters for Shipbuilding", Ship Structure Committee Report SSC-296, February 1980.
2. Rules for Building and Classing Steel Vessels, The American Bureau of Shipping, 1981.
3. NAVSHIPS 0900-014-5010, "Fabrication, Welding, and Inspection of Non Combatant Ship Hulls", dated December 1966.
4. NAVSHIPS 0900-000-1000 with 0900-000-1001, "Fabrication, Welding, and Inspection of Ship Hulls", dated 1 October 1968 with change 1 dated 1 June 1969.
5. NAVSHIPS 0900-006-9010, "Fabrication, Welding, and Inspection of HY-80/100 Submarine Hulls", dated 1 September 1971.
6. MIL-STD-1628(SHIPS), "Fillet Weld Size, Strength, and Efficiency Determination", 28 June 1974.
7. Kato, Ben; and Morita, Koji; "Strength of Transverse Fillet Welded Joints", Welding Research Supplement, February 1974.
8. Butler, L. J.; and Kulak, G. L.; "Strength of Fillet Welds as a Function of Direction of Load", Welding Research Supplement, May 1971.
9. Welding Kaiser Aluminum, Kaiser Aluminum and Chemical Sales, Inc., 1967.
10. Brockenbrough, R. L. and Johnson, B. G., "USS Steel Design Manual", United States Steel Corporation, 1974.
11. MIL-STD-0022D, "Military Standard Welded Joint Design", dated 25 May 1979 with Notice 1 dated 12 February 1982.
12. Basar, N. S., and Stanley, R. F., "Survey of Structural Tolerances in the United States Commercial Shipbuilding Industry", April 1978, SSC-273.
13. Graville, B. A., and Read, J. A., "Optimization of Fillet Weld Sizes", Welding Research Supplement, April, 1974.
14. Structural Welding Code - Steel, American Welding Society publication ANSI/AWS D1.1-81, effective January 1, 1981.
15. McCabe, W.C., "A Comparison of Fillet Weld Strength and U.S. Navy Design Specifications for Non-combatant Ships and the Economic Implications", MIT Engineers thesis, Dept. of Ocean Engineering, May, 1978.
16. Kiss, R. K., and Garvey, J. L., "CMX Designs - Merchant Ships for the '70's", Marine Technology, October 1970.

ACKNOWLEDGEMENTS

The authors express their appreciation to the members of the ad hoc Project Advisory Committee of the National Research Council for their thorough review and constructive comments on this work. Appreciation is also expressed to Mr. D. B. McNally for his assistance with the calculations, Mr. M. W. Pratt for the figures, and Mrs. Doris W. Jones for her patience with the manuscript.

R-2

486-330 - 70

APPENDIX A

ABS FILLET WELD SIZES

A-1

486-330 - (71)

TABLE 30.1

Double Continuous Fillet Weld Sizes—Inches

For leg requirements for thicknesses intermediate to those shown in the table, use the nearest lower thickness shown in the table.

For thickness less than 5/16 in. the leg size is not to be less than 0.625t except for unbracketed end connections where the leg size is to be 0.7t. The thickness t is the lesser thickness of members joined except where Note 1 at the end of the table applies. The leg size is not to be less than 11/64 in.

For vessels to be classed "Oil Carrier" the leg size in cargo tanks and in ballast tanks in the cargo area is not to be less than 1/4 in. except where approval has been given in accordance with 30.9.2a or b.

Where Type A or B appears in the Structural Items column, refer to 30.9.7 for weld description and arrangement.

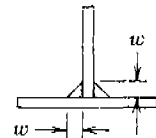

w = nominal leg size, in.

Line No.	Weld Gr.	ABS Structural Items	Leg size for lesser thickness of members joined, in.																	
			0.32	0.36	0.40	0.44	0.48	0.52	0.56	0.60	0.64	0.68	0.72	0.76	0.80	0.84	0.89	0.92	0.96	1.00
Single Bottom Floors																				
1	C	To center vertical keel	3/16	7/32	1/4	1/4	9/32	5/16	5/16	11/32	3/8	3/8	13/32	7/16	7/16	15/32	1/2	1/2	17/32	9/16
2	F	To shell—aft peak of high power fine form vessels	3/16	3/16	3/16	7/32	7/32	1/4	1/4	1/4	1/4	9/32	9/32	5/16	5/16	5/16	5/16	11/32	11/32	3/8
3	M	To shell—flat of bottom forward and in peaks	3/16	3/16	3/16	3/16	3/16	3/16	7/32	7/32	7/32	1/4	1/4	1/4	1/4	1/4	1/4	9/32	9/32	5/16
4	M	To shell—elsewhere	3/16	3/16	3/16	3/16	3/16	3/16	7/32	7/32	7/32	1/4	1/4	1/4	1/4	1/4	1/4	9/32	9/32	5/16
5	M	To face plate, Type B	3/16	3/16	3/16	3/16	3/16	3/16	7/32	7/32	7/32	1/4	1/4	1/4	1/4	1/4	1/4	9/32	9/32	5/16
6	C	To side shell, longitudinal bulkhead or other supporting member	3/16	7/32	1/4	1/4	9/32	5/16	5/16	11/32	3/8	3/8	13/32	7/16	7/16	15/32	1/2	1/2	17/32	9/16
Double Bottom Floors —Plate Floors																				
7	F	To shell—aft peaks of high power, fine form vessels	3/16	3/16	3/16	7/32	7/32	1/4	1/4	1/4	1/4	9/32	9/32	5/16	5/16	11/32	5/16	11/32	11/32	3/8
8	M	To shell—flat of bottom forward and in peaks	3/16	3/16	3/16	3/16	3/16	3/16	7/32	7/32	7/32	1/4	1/4	1/4	9/32	1/4	9/32	9/32	5/16	
9	M	To shell elsewhere (See Note 5)	3/16	3/16	3/16	3/16	3/16	3/16	7/32	7/32	7/32	1/4	1/4	1/4	1/4	1/4	9/32	9/32	5/16	
10	M	To center vertical keel and side girders where floor is continuous	3/16	3/16	3/16	3/16	3/16	3/16	7/32	7/32	7/32	1/4	1/4	1/4	1/4	1/4	9/32	9/32	5/16	
11	C	To center vertical keel and side girders where longitudinal girder is continuous	3/16	7/32	1/4	1/4	9/32	5/16	5/16	11/32	3/8	3/8	13/32	7/16	7/16	15/32	1/2	1/2	17/32	9/16
12	C	To sloping margin plate, side shell, and bilge	3/16	7/32	1/4	1/4	9/32	5/16	5/16	11/32	3/8	3/8	13/32	7/16	7/16	15/32	1/2	1/2	17/32	9/16
13	A	To vertical margin plate, or side girder under longitudinal or wing tank bulkhead (See Note 1)	1/4	1/4	5/16	5/16	3/8	3/8	7/16	7/16	1/2	1/2	17/32	9/16	19/32	5/8	21/32	11/16	23/32	3/4
14	C	To inner bottom in machinery space	3/16	7/32	1/4	1/4	9/32	5/16	5/16	11/32	3/8	3/8	13/32	7/16	7/16	15/32	1/2	1/2	17/32	9/16
15	K	To inner bottom at forward end (fore-end strengthening), Type B	3/16	3/16	3/16	3/16	3/16	3/16	7/32	7/32	7/32	1/4	1/4	1/4	1/4	9/32	9/32	9/32	5/16	
16	K	To inner bottom elsewhere Type B (See Note 5)	3/16	3/16	3/16	3/16	3/16	3/16	7/32	7/32	7/32	1/4	1/4	1/4	1/4	9/32	9/32	9/32	5/16	
17	C	At watertight and oiltight periphery connections	3/16	7/32	1/4	1/4	9/32	5/16	5/16	11/32	3/8	3/8	13/32	7/16	7/16	15/32	1/2	1/2	17/32	9/16
18	K	Stiffeners, Type B	3/16	3/16	3/16	3/16	3/16	3/16	7/32	7/32	7/32	1/4	1/4	1/4	1/4	9/32	9/32	9/32	5/16	
Double Bottom Floors —Open Floor Brackets																				
19	K	To center vertical keel, Type A	3/16	3/16	3/16	3/16	3/16	3/16	7/32	7/32	7/32	1/4	1/4	1/4	1/4	9/32	9/32	9/32	5/16	
20	C	To margin plate, Type A		7/32	1/4	1/4	9/32	5/16	5/16	11/32	3/8	3/8	13/32	7/16	7/16	15/32	1/2	1/2	17/32	9/16

TABLE 30.1 (continued)

Inches

Line No.	ABS Weld Gr.	Structural Items	Leg size for lesser thickness of members joined, in.																	
			0.32	0.36	0.40	0.44	0.48	0.52	0.56	0.60	0.64	0.68	0.72	0.76	0.80	0.84	0.88	0.92	0.96	1.00
Double Bottom																				
—Center Girder																				
21	C	To inner bottom in way of engine	3/16	7/32	1/4	1/4	9/32	5/16	5/16	11/32	3/8	3/8	13/32	7/16	7/16	15/32	1/2	1/2	17/32	9/16
22	F	To inner bottom clear of engine, Type B	3/16	3/16	3/16	7/32	7/32	1/4	1/4	1/4	1/4	9/32	9/32	5/16	5/16	5/16	5/16	11/32	11/32	3/8
23	C	To shell or bar keel	3/16	7/32	1/4	1/4	9/32	5/16	5/16	11/32	3/8	3/8	13/32	7/16	7/16	15/32	1/2	1/2	17/32	9/16
24	C	At watertight and oiltight periphery connections	3/16	7/32	1/4	1/4	9/32	5/16	5/16	11/32	3/8	3/8	13/32	7/16	7/16	15/32	1/2	1/2	7/32	9/16
25	K	Stiffeners, Type B	3/16	3/16	3/16	3/16	3/16	3/16	3/16	7/32	7/32	7/32	1/4	1/4	1/4	1/4	9/32	9/32	9/32	5/16
Double Bottom Side Girders																				
26	F	To shell—flat of bottom forward (fore end strengthening)	3/16	3/16	3/16	7/32	7/32	1/4	1/4	1/4	1/4	9/32	9/32	5/16	5/16	5/16	5/16	11/32	11/32	3/8
27	M	To shell elsewhere	3/16	3/16	3/16	3/16	3/16	3/16	3/16	3/16	7/32	7/32	1/4	1/4	1/4	1/4	1/4	9/32	9/32	5/16
28	F	To inner bottom in way of engines, Type B	3/16	3/16	3/16	7/32	7/32	1/4	1/4	1/4	1/4	9/32	9/32	5/16	5/16	5/16	5/16	11/32	11/32	3/8
29	M	To inner bottom elsewhere, Type B	3/16	3/16	3/16	3/16	3/16	3/16	3/16	7/32	7/32	7/32	1/4	1/4	1/4	1/4	1/4	9/32	9/32	5/16
30	C	To floors in way of transverse bulkheads	3/16	7/32	1/4	1/4	9/32	5/16	5/16	11/32	3/8	3/8	13/32	7/16	7/16	15/32	1/2	1/2	17/32	9/16
31	M	To floors elsewhere, Type B	3/16	3/16	3/16	3/16	3/16	3/16	3/16	7/32	7/32	7/32	1/4	1/4	1/4	1/4	1/4	9/32	9/32	5/16
32	C	At oiltight and watertight periphery connections	3/16	7/32	1/4	1/4	9/32	5/16	5/16	11/32	3/8	3/8	13/32	7/16	7/16	15/32	1/2	1/2	17/32	9/16
33	M	Stiffeners, Type B	3/16	3/16	3/16	3/16	3/16	3/16	3/16	7/32	7/32	7/32	1/4	1/4	1/4	1/4	1/4	9/32	9/32	5/16
Inner Bottom																				
—Plating																				
34	C	To shell and to other boundaries	3/16	7/32	1/4	1/4	9/32	5/16	5/16	11/32	3/8	3/8	13/32	7/16	7/16	15/32	1/2	1/2	17/32	9/16
Frames																				
—Transverse																				
35	F	To shell—aft peaks of high power, fine form vessels	3/16	3/16	3/16	7/32	7/32	1/4	1/4	1/4	1/4	9/32	9/32	5/16	5/16	5/16	5/16	11/32	11/32	3/8
36	M	To shell for 0.125L forward	3/16	3/16	3/16	3/16	3/16	3/16	3/16	7/32	7/32	7/32	1/4	1/4	1/4	1/4	1/4	9/32	9/32	5/16
37	M	To shell in peaks	3/16	3/16	3/16	3/16	3/16	3/16	3/16	7/32	7/32	7/32	1/4	1/4	1/4	1/4	1/4	9/32	9/32	5/16
38	M	To shell elsewhere	3/16	3/16	3/16	3/16	3/16	3/16	3/16	7/32	7/32	7/32	1/4	1/4	1/4	1/4	1/4	9/32	9/32	5/16
39	B	Unbracketed, to inner bottom (See Note 1), Type A	7/32	1/4	1/4	9/32	5/16	5/16	11/32	3/8	3/8	13/32	7/16	7/16	15/32	1/2	1/2	17/32	9/16	9/16
40	D	Frame brackets to frames, decks and inner bottom, Type A	3/16	3/16	7/32	1/4	1/4	9/32	5/16	5/16	11/32	3/8	3/8	13/32	7/16	7/16	15/32	1/2	1/2	17/32
Frames																				
—Transverse, Reverse																				
41	L	To inner bottom, Type B	3/16	3/16	3/16	3/16	3/16	3/16	3/16	7/32	7/32	7/32	1/4	1/4	1/4	1/4	1/4	5/16	5/16	5/16
42	D	To brackets, Type A	3/16	3/16	7/32	1/4	1/4	9/32	5/16	5/16	11/32	3/8	3/8	13/32	7/16	7/16	15/32	1/2	1/2	17/32
Frames																				
—Longitudinal																				
43	M	To shell for 0.125L forward	3/16	3/16	3/16	3/16	3/16	3/16	3/16	7/32	7/32	7/32	1/4	1/4	1/4	1/4	1/4	9/32	9/32	5/16
44	M	To shell in peaks	3/16	3/16	3/16	3/16	3/16	3/16	3/16	7/32	7/32	7/32	1/4	1/4	1/4	1/4	1/4	9/32	9/32	5/16
45	I	To shell on flat of bottom forward	3/16	3/16	3/16	3/16	1/4	1/4	1/4	1/4	1/4	1/4	9/32	9/32	9/32	9/32	5/16	5/16	5/16	5/16

TABLE 30.1 (continued)

Inches

Line No.	ABS Weld Gr.	Structural Items	Leg size for lesser thickness of members joined, in.																		
			0.32	0.36	0.40	0.44	0.48	0.52	0.56	0.60	0.64	0.68	0.72	0.76	0.80	0.84	0.88	0.92	0.96	1.00	
Frames																					
—Longitudinal (cont'd)																					
46	M	To shell elsewhere	3/16	3/16	3/16	3/16	3/16	3/16	3/16	7/32	7/32	7/32	1/4	1/4	1/4	1/4	1/4	9/32	9/32	5/16	
47	M	To inner bottom, Type B	3/16	3/16	3/16	3/16	3/16	3/16	3/16	7/32	7/32	7/32	1/4	1/4	1/4	1/4	1/4	9/32	9/32	5/16	
48	D	Brackets to longitudinals, floors, etc., Type A	3/16	3/16	7/32	1/4	1/4	9/32	5/16	5/16	11/32	3/8	3/8	13/32	7/16	7/16	15/32	1/2	1/2	17/32	
Girders, Web Frames, Stringers and Deck Transverses																					
49	G	To shell and to bulkheads and decks in way of tanks	3/16	3/16	3/16	3/16	3/16	3/16	7/32	7/32	7/32	1/4	1/4	1/4	1/4	1/4	13/32	13/32	13/32	7/16	7/16
50	H	To decks and bulkheads clear of tanks	3/16	3/16	3/16	3/16	3/16	3/16	7/32	7/32	7/32	7/32	1/4	1/4	1/4	1/4	1/4	13/32	13/32	7/16	
51	A	End attachments, unbracketed (See Note 1), Type A	1/4	1/4	5/16	5/16	3/8	3/8	7/16	7/16	1/2	1/2	17/32	9/16	5/8	5/8	21/32	11/16	23/32	3/4	
52	B	End attachments, bracketed, Type A	7/32	1/4	1/4	9/32	5/16	5/16	11/32	3/8	3/8	13/32	7/16	7/16	15/32	1/2	1/2	17/32	9/16	9/16	
53	M	To face plate	3/16	3/16	3/16	3/16	3/16	3/16	3/16	7/32	7/32	7/32	1/4	1/4	1/4	1/4	1/4	9/32	9/32	5/16	
Bulkheads																					
—Plating																					
54	J	Swash bulkheads—periphery	3/16	3/16	3/16	3/16	3/16	3/16	7/32	7/32	1/4	1/4	1/4	1/4	1/4	9/32	9/32	9/32	5/16	5/16	
55	M	Non-tight bulkhead—periphery	3/16	3/16	3/16	3/16	3/16	3/16	3/16	7/32	7/32	7/32	1/4	1/4	1/4	1/4	1/4	9/32	9/32	5/16	
56	C	Oiltight or watertight bulkheads—periphery	3/16	7/32	1/4	1/4	9/32	5/16	5/16	11/32	3/8	3/8	13/32	7/16	7/16	15/32	1/2	1/2	1/2	9/16	
57	C	Exposed bulkhead on freeboard or superstructure deck—periphery	3/16	7/32	1/4	1/4	9/32	5/16	5/16	11/32	3/8	3/8	13/32	7/16	7/16	15/32	1/2	1/2	1/2	9/16	
Bulkheads																					
—Stiffeners																					
58	M	To deep tank bulkheads, Type B	3/16	3/16	3/16	3/16	3/16	3/16	3/16	7/32	7/32	7/32	1/4	1/4	1/4	1/4	1/4	9/32	9/32	5/16	
59	M	To watertight bulkheads and superstructure or deck house front bulkheads, Type B	3/16	3/16	3/16	3/16	3/16	3/16	3/16	7/32	7/32	7/32	1/4	1/4	1/4	1/4	1/4	9/32	9/32	5/16	
60	M	To non-tight structural bulkheads, Type B	3/16	3/16	3/16	3/16	3/16	3/16	3/16	7/32	7/32	7/32	1/4	1/4	1/4	1/4	1/4	9/32	9/32	5/16	
61	M	To deck house sides and deck house and superstructure end bulkheads, Type B	3/16	3/16	3/16	3/16	3/16	3/16	3/16	7/32	7/32	7/32	1/4	1/4	1/4	1/4	1/4	9/32	9/32	5/16	
62	B	End attachments—unbracketed (See Note 1), Type A	7/32	1/4	1/4	9/32	5/16	5/16	11/32	3/8	3/8	13/32	7/16	7/16	15/32	1/2	1/2	17/32	9/16	9/16	
63	D	Brackets to stiffeners, bulkhead, deck, inner bottom, etc., Type A	3/16	3/16	7/32	1/4	1/4	9/32	5/16	5/16	11/32	3/8	3/8	13/32	7/16	7/16	15/32	1/2	1/2	17/32	
Decks																					
—Plating																					
64	C	Strength deck—periphery	3/16	7/32	1/4	1/4	9/32	5/16	5/16	11/32	3/8	3/8	13/32	7/16	7/16	15/32	1/2	1/2	17/32	9/16	
65	C	Exposed decks, water-tight and oil-tight decks—periphery	3/16	7/32	1/4	1/4	9/32	5/16	5/16	11/32	3/8	3/8	13/32	7/16	7/16	15/32	1/2	1/2	17/32	9/16	
66	E	Platform decks non-tight flats—periphery	3/16	7/32	7/32	1/4	1/4	1/4	9/32	9/32	5/16	5/16	5/16	11/32	11/32	3/8	3/8	13/32	13/32	7/16	

TABLE 30.1 (continued)

Inches

Line No.	ABS Weld Gr.	Structural Items	Leg size for lesser thickness of members joined, in.																	
			0.32	0.36	0.40	0.44	0.48	0.52	0.56	0.60	0.64	0.68	0.72	0.76	0.80	0.84	0.88	0.92	0.96	1.00
Decks																				
—Beams and Longitudinals																				
67	M	To decks, except slab longitudinals, Type B	3/16	3/16	3/16	3/16	3/16	3/16	3/16	7/32	7/32	7/32	1/4	1/4	1/4	1/4	1/4	9/32	9/32	5/16
68	M	To decks, slab longitudinals (See Note 2), Type B	3/16	3/16	3/16	3/16	3/16	3/16	3/16	7/32	7/32	7/32	1/4	1/4	1/4	1/4	1/4	9/32	9/32	5/16
69	B	End attachments, beams, unbracketed (See Note 1), Type A	7/32	1/4	1/4	9/32	5/16	5/16	11/32	3/8	3/8	13/32	7/16	7/16	15/32	1/2	1/2	17/32	9/16	9/16
70	D	Beam knees and brackets to beams, longitudinals, deck, bulkhead, etc., Type A	3/16	3/16	7/32	1/4	1/4	9/32	5/16	5/16	11/32	3/8	3/8	13/32	7/16	7/16	15/32	1/2	1/2	17/32
Decks																				
—Hatch Coamings and Ventilators																				
71	C	To deck	3/16	7/32	1/4	1/4	9/32	5/16	5/16	11/32	3/8	3/8	13/32	7/16	7/16	15/32	1/2	1/2	17/32	9/16
Hatch Covers																				
—Plating																				
72	C	Watertight or oiltight periphery	3/16	7/32	1/4	1/4	9/32	5/16	5/16	11/32	3/8	3/8	13/32	7/16	7/16	15/32	1/2	1/2	17/32	9/16
Hatch Covers																				
—Stiffeners and Webs																				
73	M	To plating and to face plate	3/16	3/16	3/16	3/16	3/16	3/16	3/16	7/32	7/32	7/32	1/4	1/4	1/4	1/4	1/4	9/32	9/32	5/16
74	B	End attachment—unbracketed to side plate or other stiffener (See Note 1), Type A	7/32	1/4	1/4	9/32	5/16	5/16	11/32	3/8	3/8	13/32	7/16	7/16	15/32	1/2	1/2	17/32	9/16	9/16
75	D	Bracket to stiffener or side plate, Type A	3/16	3/16	7/32	1/4	1/4	9/32	5/16	5/16	11/32	3/8	3/8	13/32	7/16	7/16	15/32	1/2	1/2	17/32
Foundations																				
—Main Engine, Major Auxiliaries																				
76	B	To top plate, shell or inner bottom	7/32	1/4	1/4	9/32	5/16	5/16	11/32	3/8	3/8	13/32	7/16	7/16	15/32	1/2	1/2	17/32	9/16	9/16
Foundations																				
—Boilers and Other Auxiliaries																				
77	C	To top plate, shell or inner bottom	3/16	7/32	1/4	1/4	9/32	5/16	5/16	11/32	3/8	3/8	13/32	7/16	7/16	15/32	1/2	1/2	17/32	9/16
Rudders																				
—Horizontal Diaphragms																				
78	F	To side plating	3/16	3/16	3/16	7/32	7/32	1/4	1/4	1/4	1/4	9/32	9/32	5/16	5/16	5/16	5/16	11/32	11/32	3/8
79	B	To vertical diaphragm in way of rudder axis	7/32	1/4	1/4	9/32	5/16	5/16	11/32	3/8	3/8	13/32	7/16	7/16	15/32	1/2	1/2	17/32	9/16	9/16
—Vertical Diaphragms																				
80	F	To side plating	3/16	3/16	3/16	7/32	7/32	1/4	1/4	1/4	1/4	9/32	9/32	5/16	5/16	5/16	5/16	11/32	11/32	3/8
81	F	To horizontal diaphragms	3/16	3/16	3/16	7/32	7/32	1/4	1/4	1/4	1/4	9/32	9/32	5/16	5/16	5/16	5/16	11/32	11/32	3/8
In way of rudder axis to top and bottom castings			Full penetration welds																	
—Side Plating																				
82	B	Slot welds (See Note 4)	7/32	1/4	1/4	9/32	5/16	5/16	11/32	3/8	3/8	13/32	7/16	7/16	15/32	1/2	1/2	17/32	9/16	9/16

TABLE 30.1 (continued)

Inches

Line No.	ABS Weld Gr.	Structural Items	Leg size for lesser thickness of members joined, in.																
			0.32	0.36	0.40	0.44	0.48	0.52	0.56	0.60	0.64	0.68	0.72	0.76	0.80	0.84	0.88	0.92	0.96

Additional Welding Requirements for Vessels Classed "Oil Carrier"

Girders and Webs

83	N	Centerline girder to shell	1/4	1/4	9/32	5/16	5/16	11/32	3/8	13/32	7/16	7/16	1/2	1/2	17/32	9/16	9/16	19/32	5/8	21/32
84	P	Centerline girder to shell, mid 0.5 span (See Note 3)	1/4	1/4	1/4	1/4	1/4	9/32	5/16	11/32	11/32	3/8	13/32	7/16	7/16	7/16	15/32	1/2	17/32	17/32
85	O	Centerline girder to deck	1/4	1/4	1/4	9/32	5/16	5/16	11/32	3/8	3/8	13/32	7/16	7/16	15/32	1/2	1/2	17/32	9/16	9/16
86	Q	Centerline girder to deck, mid 0.5 span (See Note 3)	1/4	1/4	1/4	1/4	1/4	9/32	5/16	5/16	5/16	11/32	3/8	3/8	13/32	13/32	7/16	15/32	15/32	
87	O	Transverse bulkhead, webs to bulkhead	1/4	1/4	1/4	9/32	5/16	5/16	11/32	3/8	3/8	13/32	7/16	7/16	15/32	1/2	1/2	17/32	9/16	9/16
88	Q	Transverse bulkhead, webs to bulkhead, mid 0.5 span (See Note 3)	1/4	1/4	1/4	1/4	1/4	9/32	5/16	5/16	5/16	11/32	3/8	3/8	13/32	7/16	7/16	15/32	15/32	
89	R	To face bars	1/4	1/4	1/4	1/4	1/4	1/4	9/32	9/32	5/16	5/16	5/16	5/16	5/16	5/16	11/32	11/32	3/8	7/8

End Attachments

90	N	Bracketed, Type A	1/4	1/4	9/32	5/16	5/16	11/32	3/8	13/32	7/16	7/16	1/2	1/2	17/32	9/16	9/16	19/32	5/8	21/32
----	---	-------------------	-----	-----	------	------	------	-------	-----	-------	------	------	-----	-----	-------	------	------	-------	-----	-------

Transverses

91	N	Bottom transverse to shell	1/4	1/4	9/32	5/16	5/16	11/32	3/8	13/32	7/16	7/16	1/2	1/2	17/32	9/16	9/16	19/32	5/8	21/32
92	P	Bottom transverse to shell mid 0.5 span (See Note 3)	1/4	1/4	1/4	1/4	1/4	9/32	5/16	11/32	11/32	3/8	13/32	7/16	7/16	7/16	15/32	1/2	17/32	17/32
93	O	Side transverse and longitudinal bulkhead web to plating	1/4	1/4	1/4	9/32	5/16	5/16	11/32	3/8	3/8	13/32	7/16	7/16	15/32	1/2	1/2	17/32	9/16	9/16
94	O	Deck transverse to deck	1/4	1/4	1/4	9/32	5/16	5/16	11/32	3/8	3/8	13/32	7/16	7/16	15/32	1/2	1/2	17/32	9/16	9/16
95	Q	Deck transverse to deck, mid 0.5 span (See Note 3)	1/4	1/4	1/4	1/4	1/4	9/32	5/16	5/16	5/16	11/32	3/8	3/8	13/32	13/32	7/16	15/32	15/32	
96	R	To face bars	1/4	1/4	1/4	1/4	1/4	1/4	9/32	9/32	5/16	5/16	5/16	5/16	5/16	5/16	11/32	11/32	3/8	3/8

SEE GENERAL NOTES AT BEGINNING OF TABLE

Notes

- 1 The weld size is to be determined from the thickness of the member being attached.
- 2 Slab longitudinals—where the thickness on which the weld size is based is greater than 1.0 in. the leg size is not to be less than 0.3 times that thickness but need not be greater than 5/16 in. provided the lesser thickness of members being joined is no greater than 1.34 in. Where the lesser thickness of members being joined is greater than 1.34 in. special consideration will be given to the weld size.
- 3 This may be applied only where the shearing forces over the mid-half span are no greater than one half the maximum shearing force on the member and where the web is of the same depth clear of end brackets and of the same thickness throughout the length of the member. The weld size is to be determined from the thickness of member being attached.
- 4 The weld size is to be determined from the thickness of the side plating.
- 5 With longitudinal framing the weld size is to be increased to give an equivalent weld area to that obtained without cut-outs for longitudinals.

TABLE 30.2
Intermittent Fillet Weld Sizes and Spacing—Inches

For weld requirements for thicknesses intermediate to those shown in the table use the nearest lower thickness shown in the table.

For vessels to be classed "Oil Carrier" the leg size in cargo tanks and in ballast tanks in the cargo area is not to be less than 1/4 in. except where approval has been given in accordance with 30.9.2a or b.

Where beams, stiffeners, frames, etc., are intermittently welded and pass through slotted girders, shelves or stringers, there is to be a pair of matched intermittent welds on each side of each such intersection and the beams, stiffeners and frames are to be efficiently attached to the girders, shelves and stringers.

Weld sizes other than given in the table may be used provided the spacing of welds is modified to give equivalent strength.

For double continuous weld sizes equivalent to the intermittent welds see Table 30.1

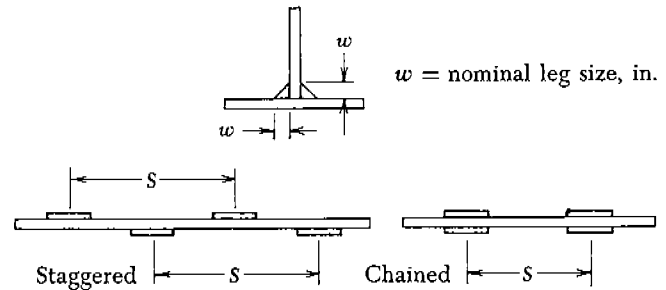

Leg size for lesser thickness of members joined, in.

		0.20	0.24	0.28	0.32	0.36	0.40	0.44	0.48	0.52	0.56	0.60	0.64						
Nominal leg size of fillet w		3/16	3/16	1/4	1/4	1/4	5/16	5/16	5/16	5/16	5/16	5/16	5/16						
Length of fillet weld		2 1/8	2 1/2	3	3	3	3	3	3	3	3	3	3						
Line No.		Structural Items						Spacing of Welds S , in.											
Gr.		Single-Bottom Floors																	
1		To center vertical keel						See Table 30.1 for double continuous welds											
2	F2	To shell—aft peaks of high power, fine form vessels						—	—	6	6	5	6	6	6	6	6	5	—
3	M2	To shell—flat of bottom forward and in peaks						—	—	10	10	9	10	10	10	9	9	8	8
4	M4	To shell—elsewhere						†12	†12	12	12	11	12	12	11	10	10	10	10
5	M4	To face plate						†12	†12	12	12	11	12	12	11	10	10	10	10
6		To side shell, longitudinal bulkhead or other supporting member						See Table 30.1 for double continuous welds											
		Double Bottom Floors																	
		—Plate Floors																	
7	F2	To shell—aft peaks of high power, fine form vessels						—	—	6	6	5	6	6	6	6	6	5	—
8	M2	To shell—flat of bottom forward and in peaks						—	—	10	10	9	10	10	10	9	9	8	8
9	M4	To shell elsewhere (See Note 5)						†12	†12	12	12	11	12	12	11	10	10	10	10
10	M1	To center vertical keel and side girders where floor is continuous						†10	†10	10	10	9	10	10	9	8	8	7	7
11		To center vertical keel and side girders where longitudinal girder is continuous						See Table 30.1 for double continuous welds											
12		To sloping margin plate, side shell, and bilge						See Table 30.1 for double continuous welds											
13		To vertical margin plate or side girder under longitudinal or wing tank bulkhead						See Table 30.1 for double continuous welds											
14		To inner bottom in machinery space						See Table 30.1 for double continuous welds											
15	K2	To inner bottom at forward end (fore end strengthening)						†11	†11	11	11	10	11	11	10	9	9	8	8
16	K3	To inner bottom—elsewhere (See Note 5)						†12	†12	12	12	11	12	12	11	10	10	10	10
17		Oiltight and watertight periphery connections						See Table 30.1 for double continuous welds											
18	K3	Stiffeners						—	12	12	12	11	12	12	11	10	10	10	10
		Double Bottom Floors																	
		—Open Floor Brackets																	
19	K1	To center vertical keel						†10	†10	10	10	9	10	10	9	8	8	7	7
20		To margin plate						See Table 30.1 for double continuous welds											

TABLE 30.2 (continued)

Inches

		Leg size for lesser thickness of members joined, in.												
		0.20	0.24	0.28	0.32	0.36	0.40	0.44	0.48	0.52	0.56	0.60	0.64	
		$\frac{3}{16}$	$\frac{3}{16}$	$\frac{1}{4}$	$\frac{1}{4}$	$\frac{1}{4}$	$\frac{5}{16}$	$\frac{5}{16}$	$\frac{5}{16}$	$\frac{5}{16}$	$\frac{5}{16}$	$\frac{5}{16}$	$\frac{5}{16}$	
Line No.	ABS Weld Gr.	Nominal leg size of fillet <i>w</i>	Length of fillet weld											
		Structural Items						Spacing of Welds <i>S</i> , in.						
		Double Bottom												
		—Center Girders												
21		To inner bottom in way of engine	See Table 30.1 for double continuous welds											
22	F3	To inner bottom—clear of engine—nontight	—	6	6	6	5	6	6	5	5	5	5	—
23		To shell or bar keel	See Table 30.1 for double continuous welds											
24		At oiltight and watertight periphery connections	See Table 30.1 for double continuous welds											
25	K3	Stiffeners	—	12	12	12	11	12	12	11	10	10	10	10
		Double Bottom												
		—Side Girders												
26	F3	To shell—flat of bottom forward (fore and strengthening)	—	6	6	6	5	6	6	5	5	5	5	—
27	M3	To shell—elsewhere	†11	†11	11	11	10	11	11	10	9	9	8	8
28	F3	To inner bottom in way of engines	—	6	6	6	5	6	6	5	5	5	5	—
29	M3	To inner bottom—elsewhere	†11	†11	11	11	10	11	11	10	9	9	8	8
30		To floors in way of transverse bulkheads	See Table 30.1 for double continuous welds											
31	M3	To floors—elsewhere	†11	†11	11	11	10	11	11	10	9	9	8	8
32		At oiltight and watertight periphery connections	See Table 30.1 for double continuous welds											
33	M4	Stiffeners	12	12	12	12	11	12	12	11	10	10	10	10
		Inner Bottom												
		—Plating												
34		To shell and to other boundaries	See Table 30.1 for double continuous welds											
		Frames												
		—Transverse												
35	F2	To shell—aft peaks of high power, fine form vessels	—	—	6	6	5	6	6	6	6	5	5	—
36	M2	To shell for 0.125 <i>L</i> forward	—	—	10	10	9	10	10	10	9	9	8	8
37	M2	To shell in peaks	—	—	10	10	9	10	10	10	9	9	8	8
38	M4	To shell—elsewhere (See Note 1)	†12	†12	12	12	11	12	12	11	10	10	10	10
39		Unbracketed to inner bottom	See Table 30.1 for double continuous welds											
40		Frame brackets to frames, decks and inner bottom	See Table 30.1 for double continuous welds											
		Frames												
		—Transverse, Reverse												
41	L1	To inner bottom	†12	†12	12	12	11	12	12	11	10	10	10	10
42		To brackets	See Table 30.1 for double continuous welds											
		Frames												
		—Longitudinal												
43	M2	To shell for 0.125 <i>L</i> forward	—	—	10	10	9	10	10	10	9	9	8	8
44	M2	To shell in peaks	—	—	10	10	9	10	10	10	9	9	8	8
45		To shell on flat of bottom forward	See Table 30.1 for double continuous welds											

TABLE 30.2 (continued)

Inches

		Leg size for lesser thickness of members joined, in.											
		0.20	0.24	0.28	0.32	0.36	0.40	0.44	0.48	0.52	0.56	0.60	0.64
Line No.	ABS Weld Gr.	Nominal leg size of fillet <i>w</i>	Length of fillet weld										
		Structural Items						Spacing of Welds <i>S</i> , in.					
Frames													
— Longitudinal (cont'd)													
46	M4	To shell elsewhere	†12	†12	12	12	11	12	12	11	10	10	10
47	M4	To inner bottom	†12	12	12	12	11	12	12	11	10	10	10
48		Brackets to longitudinals, floors, shell, etc.	See Table 30.1 for double continuous welds										
Girders, Web Frames, Stringers and Deck Transverses													
49	G1	To shell and to bulkheads and decks in way of tanks	—	8	9	9	8	9	9	8	7	7	6
50	H1	To decks and bulkheads clear of tanks	—	9	10	10	9	10	10	9	8	8	7
51		End connections	See Table 30.1 for double continuous welds										
53A	M4	To face plate area ≤ 10 in. ²	†10	†10	12	12	11	12	12	11	10	10	10
53B	M1	To face plate area > 10 in. ²	—	—	10	10	9	10	10	9	8	8	7
Bulkheads													
— Plating													
54	J1	Swash bulkhead—periphery	—	8	9	9	8	9	9	8	7	7	6
55	M1	Non-tight structural bulkhead—periphery	—	9	10	10	9	10	10	9	8	8	7
56A		Tank bulkheads—periphery	See Table 30.1 for double continuous welds										
56B	C1	Watertight bulkheads—periphery	Continuous weld of leg size of plate thickness less 1/16 in.										
		One side											
		Other side	See Table 30.1 for double continuous weld										
57		Exposed bulkheads on freeboard and superstructure decks—periphery	See Table 30.1 for double continuous welds										
Bulkheads													
— Stiffeners													
58	M4	To deep tank bulkheads (See Note 1)	—	†12	12	12	11	12	12	11	10	10	10
59	M4	To watertight bulkheads and superstructure or deckhouse front—bulkheads (See Note 1)	—	†12	12	12	11	12	12	11	10	10	10
60	M5	To non-tight structural bulkhead (See Note 2)	†12	†12	12	12	12	12	12	12	12	12	10
61	M5	To deckhouse side and superstructure end bulkheads (See Note 2)	†12	†12	12	12	12	12	12	12	12	12	10
62		End attachments	See Table 30.1 for double continuous welds										
63		Brackets	See Table 30.1 for double continuous welds										
Decks													
— Plating													
64		Strength deck—periphery	See Table 30.1 for double continuous welds										
65		Exposed deck, watertight and oiltight flat—periphery	See Table 30.1 for double continuous welds										
66		Platform decks, non-tight flats—periphery	See Table 30.1 for double continuous welds										

TABLE 30.2 (continued)

Inches

			Leg size for lesser thickness of members joined, in.											
			0.20	0.24	0.28	0.32	0.36	0.40	0.44	0.48	0.52	0.56	0.60	0.64
Line No.	ABS Weld Gr.		$\frac{3}{16}$	$\frac{3}{16}$	$\frac{1}{4}$	$\frac{1}{4}$	$\frac{1}{4}$	$\frac{5}{16}$	$\frac{5}{16}$	$\frac{5}{16}$	$\frac{5}{16}$	$\frac{5}{16}$	$\frac{5}{16}$	$\frac{5}{16}$
			Spacing of Welds S, in.											
Decks														
—Beams and Longitudinals														
67	M4	To decks, except slab longitudinals	†12	†12	12	12	11	12	12	11	10	10	10	10
68		To decks, slab longitudinals	See Table 30.1 for double continuous welds											
69		End attachments	See Table 30.1 for double continuous welds											
70		Beam knees and brackets	See Table 30.1 for double continuous welds											
Decks														
—Hatch Coamings and Ventilators														
71		To deck	See Table 30.1 for double continuous welds											
Hatch Covers														
—Plating														
72A		Oiltight—periphery	See Table 30.1 for double continuous welds											
72B	C2	Weathertight—periphery	Continuous weld of same leg size as required for inside intermittent weld											
		Outside	—	12	12	12	11	12	12	11	10	10	10	10
		Inside												
Hatch Covers														
—Stiffeners and Webs														
73	M4	To plating and to face plate (see Note 4)	†12	†12	12	12	11	12	12	11	10	10	10	10
74		End attachment	See Table 30.1 for double continuous welds											
75		Brackets	See Table 30.1 for double continuous welds											
Foundations														
—Main Engine, Major Auxilliaries														
76		To top plate shell or inner bottom	See Table 30.1 for double continuous welds											
Rudders														
—Horizontal Diaphragms														
78	F1	To side plating	4	5	6	6	5	6	6	6	6	†6	†6	†6
79		To vertical diaphragm in way of rudder axis	See Table 30.1 for double continuous welds											
—Vertical Diaphragms														
80	F1	To side plating	4	5	6	6	5	6	6	6	6	†6	†6	†6
81	F1	To horizontal diaphragms	4	5	6	6	5	6	6	6	6	†6	†6	†6
		In way of rudder axis to top and bottom castings	Full penetration welds											
—Side Plating														
82		Slot welds	See Table 30.1 for double continuous welds											

TABLE 30.2 (continued)

Inches

		Leg size for lesser thickness of members joined, in.											
		0.20	0.24	0.28	0.32	0.36	0.40	0.44	0.48	0.52	0.56	0.60	0.64
	Nominal leg size of fillet <i>w</i>	$\frac{3}{16}$	$\frac{3}{16}$	$\frac{1}{4}$	$\frac{1}{4}$	$\frac{1}{4}$	$\frac{5}{16}$	$\frac{5}{16}$	$\frac{5}{16}$	$\frac{5}{16}$	$\frac{5}{16}$	$\frac{5}{16}$	$\frac{5}{16}$
	Length of fillet weld	$2\frac{1}{8}$	$2\frac{1}{2}$	3	3	3	3	3	3	3	3	3	3
Line No.	ABS Weld Gr.	Structural Items						Spacing of Welds <i>S</i> , in.					

Additional Welding Requirements for Vessels Classed "Oil Carriers" (See Note 3)

	Girders and Webs													
89	R1	To face bars	—	—	—	6	6	6	6	5	5	5	—	—
	Transverses													
96	R1	To face bars	—	—	—	6	6	6	6	5	5	5	—	—

SEE GENERAL NOTES AT BEGINNING OF TABLE

Notes

- 1 Unbracketed stiffeners of shell, watertight and oiltight bulkheads and house fronts are to have double continuous welds for one-tenth of their length at each end.
- 2 Unbracketed stiffeners of nontight structural bulkheads, deckhouse sides and after ends are to have a pair of matched intermittent welds at each end.
- 3 The welding of deck and shell longitudinals may be as required under decks or frames. In addition the shell longitudinals are to have double continuous welds at the ends and in way of transverses equal in length to the depth of the longitudinal. The deck longitudinals are also to have double continuous welds at the ends equal in length to the depth of the longitudinal, however at transverses a matched pair of welds will be acceptable.
- 4 Unbracketed stiffeners and webs of hatch covers are to be welded continuously to the plating and to the face plate for a length at ends equal to the end depth of the member.
- 5 With longitudinal framing the welds are to be arranged to give an equivalent weld area to that obtained without cut-outs for longitudinals.
- † Fillet welds are to be staggered.
- ‡ Nominal size of fillet *w* is to be increased $\frac{1}{16}$ in.

25%

APPENDIX B

GROUPING OF ABS FILLET WELDS

APPENDIX B
GROUPING OF ABS FILLET WELDS

ABS Weld Grp.	Ln. No.	Structural Items	Leg Size for Lesser Thickness of Members Joined,													
			0.32	0.36	0.40	0.44	0.48	0.52	0.56	0.60	0.64	0.68	0.72	0.76	0.80	
A	13	To vertical margin plate, or side girder under longitudinal or wing tank bulkhead (See Note 1)	1/4	1/4	5/16	5/16	3/8	3/8	7/16	7/16	1/2	1/2	17/32	9/16	19/32	5/8
	51	End attachments, unbracketed (See Note 1), Type A	1/4	1/4	5/16	5/16	3/8	3/8	7/16	7/16	1/2	1/2	17/32	9/16	19/32	5/8
B	39	Unbracketed to Inner bottom (See Note 1), Type A	7/32	1/4	1/4	9/32	5/16	5/16	11/32	3/8	3/8	13/32	7/16	7/16	15/32	5/8
	52	End attachments, bracketed, Type A	7/32	1/4	1/4	9/32	5/16	5/16	11/32	3/8	3/8	13/32	7/16	7/16	15/32	5/8
	62	End attachments, unbracketed, (See Note 1), Type A	7/32	1/4	1/4	9/32	5/16	5/16	11/32	3/8	3/8	13/32	7/16	7/16	15/32	5/8
	69	End attachments, beams unbracketed (See Note 1), Type A	7/32	1/4	1/4	9/32	5/16	5/16	11/32	3/8	3/8	13/32	7/16	7/16	15/32	5/8
	74	End attachment - unbracketed to side plate or other stiffener (See Note 1), Type A	7/32	1/4	1/4	9/32	5/16	5/16	11/32	3/8	3/8	13/32	7/16	7/16	15/32	5/8
	76	To top plate, shell or inner bottom	7/32	1/4	1/4	9/32	5/16	5/16	11/32	3/8	3/8	13/32	7/16	7/16	15/32	5/8
	79	To vertical diaphragm in way of rudder axis	7/32	1/4	1/4	9/32	5/16	5/16	11/32	3/8	3/8	13/32	7/16	7/16	15/32	5/8
	82	Slot welds (See Note 4)	7/32	1/4	1/4	9/32	5/16	5/16	11/32	3/8	3/8	13/32	7/16	7/16	15/32	5/8

B-2

486-330 - 84

907

ABS Weld Grp.	Ln. No.	Structural Items	Leg Size for Lesser Thickness of Members Joined, in.																	
			0.32	0.36	0.40	0.44	0.48	0.52	0.56	0.60	0.64	0.68	0.72	0.76	0.80	0.84	0.88	0.92	0.96	1.00
C	1	To center vertical keel	3/16	7/32	1/4	1/4	9/32	5/16	5/16	11/32	3/8	3/8	13/32	7/16	7/16	15/32	1/2	1/2	17/32	9/16
	6	To side shell, longitudinal bulkhead or other supporting member	3/16	7/32	1/4	1/4	9/32	5/16	5/16	11/32	3/8	3/8	13/32	7/16	7/16	15/32	1/2	1/2	17/32	9/16
	11	To center vertical keel and side girders where longitudinal girder is continuous	3/16	7/32	1/4	1/4	9/32	5/16	5/16	11/32	3/8	3/8	13/32	7/16	7/16	15/32	1/2	1/2	17/32	9/16
	12	To sloping margin plate, side shell, and bilge	3/16	7/32	1/4	1/4	9/32	5/16	5/16	11/32	3/8	3/8	13/32	7/16	7/16	15/32	1/2	1/2	17/32	9/16
	14	To inner bottom in machinery space	3/16	7/32	1/4	1/4	9/32	5/16	5/16	11/32	3/8	3/8	13/32	7/16	7/16	15/32	1/2	1/2	17/32	9/16
	17	At watertight and oiltight periphery connections	3/16	7/32	1/4	1/4	9/32	5/16	5/16	11/32	3/8	3/8	13/32	7/16	7/16	15/32	1/2	1/2	17/32	9/16
	20	To margin plate, Type A		7/32	1/4	1/4	9/32	5/16	5/16	11/32	3/8	3/8	13/32	7/16	7/16	15/32	1/2	1/2	17/32	9/16
	21	To inner bottom in way of engine	3/16	7/32	1/4	1/4	9/32	5/16	5/16	11/32	3/8	3/8	13/32	7/16	7/16	15/32	1/2	1/2	17/32	9/16
	23	To shell or bar keel	3/16	7/32	1/4	1/4	9/32	5/16	5/16	11/32	3/8	3/8	13/32	7/16	7/16	15/32	1/2	1/2	17/32	9/16
	24	At watertight and oiltight periphery connections	3/16	7/32	1/4	1/4	9/32	5/16	5/16	11/32	3/8	3/8	13/32	7/16	7/16	15/32	1/2	1/2	17/32	9/16
	30	To floors in way of transverse bulkheads	3/16	7/32	1/4	1/4	9/32	5/16	5/16	11/32	3/8	3/8	13/32	7/16	7/16	15/32	1/2	1/2	17/32	9/16
	32	At oiltight and watertight periphery connections	3/16	7/32	1/4	1/4	9/32	5/16	5/16	11/32	3/8	3/8	13/32	7/16	7/16	15/32	1/2	1/2	17/32	9/16

B-3

486-330

85

90%

ABS

Weld Grp.	Ln. No.	Structural Items	Leg Size for Lesser Thickness of Members Joined, In.																	
			0.32	0.36	0.40	0.44	0.48	0.52	0.56	0.60	0.64	0.68	0.72	0.76	0.80	0.84	0.88	0.92	0.96	1.00
C	34	To shell and to other boundaries	3/16	7/32	1/4	1/4	9/32	5/16	5/16	11/32	3/8	3/8	13/32	7/16	7/16	15/32	1/2	1/2	17/32	9/16
	56	Oiltight or watertight bulkheads - periphery	3/16	7/32	1/4	1/4	9/32	5/16	5/16	11/32	3/8	3/8	13/32	7/16	7/16	15/32	1/2	1/2	17/32	9/16
	57	Exposed bulkhead on freeboard or superstructure deck - periphery	3/16	7/32	1/4	1/4	9/32	5/16	5/16	11/32	3/8	3/8	13/32	7/16	7/16	15/32	1/2	1/2	17/32	9/16
	64	Strength deck - periphery	3/16	7/32	1/4	1/4	9/32	5/16	5/16	11/32	3/8	3/8	13/32	7/16	7/16	15/32	1/2	1/2	17/32	9/16
	65	Exposed decks, watertight and oiltight decks - periphery	3/16	7/32	1/4	1/4	9/32	5/16	5/16	11/32	3/8	3/8	13/32	7/16	7/16	15/32	1/2	1/2	17/32	9/16
	71	To deck	3/16	7/32	1/4	1/4	9/32	5/16	5/16	11/32	3/8	3/8	13/32	7/16	7/16	15/32	1/2	1/2	17/32	9/16
	72	Watertight or oiltight periphery	3/16	7/32	1/4	1/4	9/32	5/16	5/16	11/32	3/8	3/8	13/32	7/16	7/16	15/32	1/2	1/2	17/32	9/16
	77	To top plate, shell or inner bottom	3/16	7/32	1/4	1/4	9/32	5/16	5/16	11/32	3/8	3/8	13/32	7/16	7/16	15/32	1/2	1/2	17/32	9/16
D	40	Frame brackets to frames, decks and inner bottom Type A	3/16	3/16	7/32	1/4	1/4	9/32	5/16	5/16	11/32	3/8	3/8	13/32	7/16	7/16	15/32	1/2	1/2	17/32
	42	To brackets, Type A	3/16	3/16	7/32	1/4	1/4	9/32	5/16	5/16	11/32	3/8	3/8	13/32	7/16	7/16	15/32	1/2	1/2	17/32
	48	Brackets to longitudinals, floors, etc., Type A	3/16	3/16	7/32	1/4	1/4	9/32	5/16	5/16	11/32	3/8	3/8	13/32	7/16	7/16	15/32	1/2	1/2	17/32
	63	Brackets to stiffeners, bulkhead, deck, inner bottom, etc., Type A	3/16	3/16	7/32	1/4	1/4	9/32	5/16	5/16	11/32	3/8	3/8	13/32	7/16	7/16	15/32	1/2	1/2	17/32

B-4

486-330-86

907

ABS			Leg Size for Lesser Thickness of Members Joined, In.																	
Weld Grp.	Ln. No.	Structural Items	0.32	0.36	0.40	0.44	0.48	0.52	0.56	0.60	0.64	0.68	0.72	0.76	0.80	0.84	0.88	0.92	0.96	1.00
D	70	Beam knees and brackets to beams, longitudinals, deck, bulkhead, etc., Type A	3/16	3/16	7/32	1/4	1/4	9/32	5/16	5/16	11/32	3/8	3/8	13/32	7/16	7/16	15/32	1/2	1/2	17/32
	75	Bracket to stiffener or side plate, Type A	3/16	3/16	7/32	1/4	1/4	9/32	5/16	5/16	11/32	3/8	3/8	13/32	7/16	7/16	15/32	1/2	1/2	17/32
E	66	Platform decks non-tight flats - periphery	3/16	7/32	7/32	1/4	1/4	1/4	9/32	9/32	5/16	5/16	5/16	11/32	11/32	3/8	3/8	13/32	13/32	7/16
F	2	To shell - aft peak of high power fine form vessels	3/16	3/16	3/16	7/32	7/32	1/4	1/4	1/4	1/4	9/32	9/32	5/16	5/16	5/16	5/16	11/32	11/32	3/8
	7	To shell - aft peaks of high power, fine form vessels	3/16	3/16	3/16	7/32	7/32	1/4	1/4	1/4	1/4	9/32	9/32	5/16	5/16	5/16	5/16	11/32	11/32	3/8
	22	To inner bottom clear of engine, Type B	3/16	3/16	3/16	7/32	7/32	1/4	1/4	1/4	1/4	9/32	9/32	5/16	5/16	5/16	5/16	11/32	11/32	3/8
	26	To shell - flat of bottom forward (fore end strengthening)	3/16	3/16	3/16	7/32	7/32	1/4	1/4	1/4	1/4	9/32	9/32	5/16	5/16	5/16	5/16	11/32	11/32	3/8
	28	To inner bottom in way of engines, Type B	3/16	3/16	3/16	7/32	7/32	1/4	1/4	1/4	1/4	9/32	9/32	5/16	5/16	5/16	5/16	11/32	11/32	3/8
	35	To shell - aft peaks of high power, fine form vessels	3/16	3/16	3/16	7/32	7/32	1/4	1/4	1/4	1/4	9/32	9/32	5/16	5/16	5/16	5/16	11/32	11/32	3/8
	78	To side plating	3/16	3/16	3/16	7/32	7/32	1/4	1/4	1/4	1/4	9/32	9/32	5/16	5/16	5/16	5/16	11/32	11/32	3/8
	80	To side plating	3/16	3/16	3/16	7/32	7/32	1/4	1/4	1/4	1/4	9/32	9/32	5/16	5/16	5/16	5/16	11/32	11/32	3/8
	81	To horizontal diaphragms	3/16	3/16	3/16	7/32	7/32	1/4	1/4	1/4	1/4	9/32	9/32	5/16	5/16	5/16	5/16	11/32	11/32	3/8

B-5

486-330

-27

907

ABS		Structural Items	Leg Size for Lesser Thickness of Members Joined, In.																	
Weld Grp.	Ln. No.		0.32	0.36	0.40	0.44	0.48	0.52	0.56	0.60	0.64	0.68	0.72	0.76	0.80	0.84	0.88	0.92	0.96	1.00
G	49	To shell and to bulkheads and decks in way of tanks	3/16	3/16	3/16	3/16	3/16	3/16	7/32	7/32	1/4	1/4	1/4	1/4	1/4	13/32	13/32	13/32	7/16	7/16
H	50	To decks and bulkheads clear of tanks	3/16	3/16	3/16	3/16	3/16	3/16	7/32	7/32	7/32	7/32	1/4	1/4	1/4	1/4	1/4	13/32	13/32	7/16
I	45	To shell on flat of bottom forward	3/16	3/16	3/16	3/16	1/4	1/4	1/4	1/4	1/4	1/4	9/32	9/32	9/32	9/32	5/16	5/16	5/16	5/16
J	54	Swash bulkheads - periphery	3/16	3/16	3/16	3/16	3/16	3/16	7/32	7/32	1/4	1/4	1/4	1/4	1/4	9/32	9/32	9/32	5/16	5/16
B-6 K	15	To inner bottom at forward end (fore-end strengthening), Type B	3/16	3/16	3/16	3/16	3/16	3/16	3/16	7/32	7/32	7/32	1/4	1/4	1/4	1/4	9/32	9/32	9/32	5/16
	16	To inner bottom elsewhere Type B (See Note 5)	3/16	3/16	3/16	3/16	3/16	3/16	3/16	7/32	7/32	7/32	1/4	1/4	1/4	1/4	9/32	9/32	9/32	5/16
	18	Stiffeners, Type B	3/16	3/16	3/16	3/16	3/16	3/16	3/16	7/32	7/32	7/32	1/4	1/4	1/4	1/4	9/32	9/32	9/32	5/16
	19	To center vertical keel, Type A	3/16	3/16	3/16	3/16	3/16	3/16	3/16	7/32	7/32	7/32	1/4	1/4	1/4	1/4	9/32	9/32	9/32	5/16
	25	Stiffeners, Type B	3/16	3/16	3/16	3/16	3/16	3/16	3/16	7/32	7/32	7/32	1/4	1/4	1/4	1/4	9/32	9/32	9/32	5/16
L	41	To inner bottom, Type B	3/16	3/16	3/16	3/16	3/16	3/16	7/32	7/32	7/32	1/4	1/4	1/4	1/4	1/4	5/16	5/16	5/16	

486-330-33

90%

ABS		Leg Size for Lesser Thickness of Members Joined, In.																		
Weld	Ln.	Structural Items																		
Grp.	No.		0.32	0.36	0.40	0.44	0.48	0.52	0.56	0.60	0.64	0.68	0.72	0.76	0.80	0.84	0.88	0.92	0.96	1.00
M	3	To shell - flat of bottom forward and in peaks	3/16	3/16	3/16	3/16	3/16	3/16	3/16	7/32	7/32	7/32	1/4	1/4	1/4	1/4	1/4	9/32	9/32	5/16
	4	To shell - elsewhere	3/16	3/16	3/16	3/16	3/16	3/16	3/16	7/32	7/32	7/32	1/4	1/4	1/4	1/4	1/4	9/32	9/32	5/16
	5	To face plate, Type B	3/16	3/16	3/16	3/16	3/16	3/16	3/16	7/32	7/32	7/32	1/4	1/4	1/4	1/4	1/4	9/32	9/32	5/16
	8	To shell - flat of bottom forward and in peaks	3/16	3/16	3/16	3/16	3/16	3/16	3/16	7/32	7/32	7/32	1/4	1/4	1/4	9/32	1/4	9/32	9/32	5/16
	9	To shell elsewhere (See Note 5)	3/16	3/16	3/16	3/16	3/16	3/16	3/16	7/32	7/32	7/32	1/4	1/4	1/4	1/4	1/4	9/32	9/32	5/16
	10	To center vertical keel and side girders where floor is continuous	3/16	3/16	3/16	3/16	3/16	3/16	3/16	7/32	7/32	7/32	1/4	1/4	1/4	1/4	1/4	9/32	9/32	5/16
	27	To shell elsewhere	3/16	3/16	3/16	3/16	3/16	3/16	3/16	7/32	7/32	7/32	1/4	1/4	1/4	1/4	1/4	9/32	9/32	5/16
	29	To inner bottom elsewhere, Type B	3/16	3/16	3/16	3/16	3/16	3/16	3/16	7/32	7/32	7/32	1/4	1/4	1/4	1/4	1/4	9/32	9/32	5/16
	31	To floors elsewhere, Type B	3/16	3/16	3/16	3/16	3/16	3/16	3/16	7/32	7/32	7/32	1/4	1/4	1/4	1/4	1/4	9/32	9/32	5/16
	33	Stiffeners, Type B	3/16	3/16	3/16	3/16	3/16	3/16	3/16	7/32	7/32	7/32	1/4	1/4	1/4	1/4	1/4	9/32	9/32	5/16
	36	To shell for 0.125L forward	3/16	3/16	3/16	3/16	3/16	3/16	3/16	7/32	7/32	7/32	1/4	1/4	1/4	1/4	1/4	9/32	9/32	5/16
	37	To shell in peaks	3/16	3/16	3/16	3/16	3/16	3/16	3/16	7/32	7/32	7/32	1/4	1/4	1/4	1/4	1/4	9/32	9/32	5/16
	38	To shell elsewhere	3/16	3/16	3/16	3/16	3/16	3/16	3/16	7/32	7/32	7/32	7/32	1/4	1/4	1/4	1/4	9/32	9/32	5/16
	43	To shell for 0.125L forward	3/16	3/16	3/16	3/16	3/16	3/16	3/16	7/32	7/32	7/32	1/4	1/4	1/4	1/4	1/4	9/32	9/32	5/16
	44	To shell in peaks	3/16	3/16	3/16	3/16	3/16	3/16	3/16	7/32	7/32	7/32	1/4	1/4	1/4	1/4	1/4	9/32	9/32	5/16
	46	To shell elsewhere	3/16	3/16	3/16	3/16	3/16	3/16	3/16	7/32	7/32	7/32	1/4	1/4	1/4	1/4	1/4	9/32	9/32	5/16

B-7

486-330-89

907,

Weid Grp.	Ln. No.	Structural Items	Leg Size for Lesser Thickness of Members Joined, In.																	
			0.32	0.36	0.40	0.44	0.48	0.52	0.56	0.60	0.64	0.68	0.72	0.76	0.80	0.84	0.88	0.92	0.96	1.00
M	47	To Inner bottom, Type B	3/16	3/16	3/16	3/16	3/16	3/16	3/16	7/32	7/32	7/32	1/4	1/4	1/4	1/4	1/4	9/32	9/32	5/16
	53	To face plate	3/16	3/16	3/16	3/16	3/16	3/16	3/16	7/32	7/32	7/32	1/4	1/4	1/4	1/4	1/4	9/32	9/32	5/16
	55	Non-tight bulkhead - periphery	3/16	3/16	3/16	3/16	3/16	3/16	3/16	7/32	7/32	7/32	1/4	1/4	1/4	1/4	1/4	9/32	9/32	5/16
	58	To deep tank bulkheads, Type B	3/16	3/16	3/16	3/16	3/16	3/16	3/16	7/32	7/32	7/32	1/4	1/4	1/4	1/4	1/4	9/32	9/32	5/16
	59	To watertight bulkheads and superstructure or deck house front bulkheads, Type B	3/16	3/16	3/16	3/16	3/16	3/16	3/16	7/32	7/32	7/32	1/4	1/4	1/4	1/4	1/4	9/32	9/32	5/16
	60	To non-tight structural bulkheads, Type B	3/16	3/16	3/16	3/16	3/16	3/16	3/16	7/32	7/32	7/32	1/4	1/4	1/4	1/4	1/4	9/32	9/32	5/16
	61	To deck house sides and deck house and superstructure end bulkheads, Type B	3/16	3/16	3/16	3/16	3/16	3/16	3/16	7/32	7/32	7/32	1/4	1/4	1/4	1/4	1/4	9/32	9/32	5/16
	67	To decks, except slab longitudinals, Type B	3/16	3/16	3/16	3/16	3/16	3/16	3/16	7/32	7/32	7/32	1/4	1/4	1/4	1/4	1/4	9/32	9/32	5/16
	68	To decks, slab longitudinals (See Note 2), Type B	3/16	3/16	3/16	3/16	3/16	3/16	3/16	7/32	7/32	7/32	1/4	1/4	1/4	1/4	1/4	9/32	9/32	5/16
	73	To plating and to face plate	3/16	3/16	3/16	3/16	3/16	3/16	3/16	7/32	7/32	7/32	1/4	1/4	1/4	1/4	1/4	9/32	9/32	5/16

ADDITIONAL RULES FOR "OIL CARRIER"

N	83	Centerline girder to shell	1/4	1/4	9/32	5/16	5/16	11/32	3/8	13/32	7/16	7/16	1/2	1/2	17/32	9/16	9/16	19/32	5/8	21/32
	90	Bracketed, Type A	1/4	1/4	9/32	5/16	5/16	11/32	3/8	13/32	7/16	7/16	1/2	1/2	17/32	9/16	9/16	19/32	5/8	21/32
	91	Bottom transverse to shell	1/4	1/4	9/32	5/16	5/16	11/32	3/8	13/32	7/16	7/16	1/2	1/2	17/32	9/16	9/16	19/32	5/8	21/32

B-8

486-330-90

90%

ABS Weld Grp.	Ln. No.	Structural Items	Leg Size for Lesser Thickness of Members Joined, In.																	
			0.32	0.36	0.40	0.44	0.48	0.52	0.56	0.60	0.64	0.68	0.72	0.76	0.80	0.84	0.88	0.92	0.96	1.00
O	85	Centerline girder to deck	1/4	1/4	1/4	9/32	5/16	5/16	11/32	3/8	3/8	13/32	7/16	7/16	15/32	1/2	1/2	17/32	9/16	9/16
	87	Transverse bulkhead, webs to bulkhead	1/4	1/4	1/4	9/32	5/16	5/16	11/32	3/8	3/8	13/32	7/16	7/16	15/32	1/2	1/2	17/32	9/16	9/16
	93	Side transverse and longitudinal bulkhead web to plating	1/4	1/4	1/4	9/32	5/16	5/16	11/32	3/8	3/8	13/32	7/16	7/16	15/32	1/2	1/2	17/32	9/16	9/16
	94	Deck transverse to deck	1/4	1/4	1/4	9/32	5/16	5/16	11/32	3/8	3/8	13/32	7/16	7/16	15/32	1/2	1/2	17/32	9/16	9/16
P	84	Centerline girder to shell, mid 0.5 span (See Note 3)	1/4	1/4	1/4	1/4	1/4	9/32	5/16	11/32	11/32	3/8	13/32	7/16	7/16	7/16	15/32	1/2	17/32	17/32
	92	Bottom transverse to shell mid 0.5 span (See Note 3)	1/4	1/4	1/4	1/4	1/4	9/32	5/16	11/32	11/32	3/8	13/32	7/16	7/16	7/16	15/32	1/2	17/32	17/32
Q	86	Centerline girder to deck, mid 0.5 span (See Note 3)	1/4	1/4	1/4	1/4	1/4	1/4	9/32	5/16	5/16	5/16	11/32	3/8	3/8	13/32	13/32	7/16	15/32	15/32
	88	Transverse bulkhead, webs to bulkhead, mid 0.5 span (See Note 3)	1/4	1/4	1/4	1/4	1/4	1/4	9/32	5/16	5/16	5/16	11/32	3/8	3/8	13/32	13/32	7/16	15/32	15/32
	95	Deck transverse to deck, mid 0.5 span (See Note 3)	1/4	1/4	1/4	1/4	1/4	1/4	9/32	5/16	5/16	5/16	11/32	3/8	3/8	13/32	13/32	7/16	15/32	15/32
R	89	To face bars	1/4	1/4	1/4	1/4	1/4	1/4	1/4	9/32	9/32	5/16	5/16	5/16	5/16	5/16	11/32	11/32	3/8	3/8
	96	To face bars	1/4	1/4	1/4	1/4	1/4	1/4	1/4	9/32	9/32	5/16	5/16	5/16	5/16	5/16	11/32	11/32	3/8	3/8

B-9

486-330-91

90%

Leg Size for Lesser Thickness of Members Joined, In.

			0.20	0.24	0.28	0.32	0.36	0.40	0.44	0.48	0.52	0.56	0.60	0.64
ABS Weld Grp.	Ln. No.	Nominal leg size of fillet	3/16	3/16	1/4	1/4	1/4	5/16	5/16	5/16	5/16	5/16	5/16	5/16
		Length of fillet weld	2-1/8	2-1/2	3	3	3	3	3	3	3	3	3	3
Structural Items			Spacing of Welds S, In.											
C1	56B	Watertight bulkheads-periphery One side	Continuous weld of leg size of plate thickness less 1/16 in.										See Table 30.1 for double continuous weld	
		Other side	-	12	12	12	11	12	12	11	See Table 30.1 for double continuous weld			
C2	72B	Weathertight-periphery Outside	Continuous weld of same leg size as required for inside intermittent weld											
		inside	-	12	12	12	11	12	12	11	10	10	10	10
F1	78	To side plating	4	5	6	6	5	6	6	6	6	† 6	† 6	† 6
F1	80	To side plating	4	5	6	6	5	6	6	6	6	† 6	† 6	† 6
F1	81	To horizontal diaphragms	4	5	6	6	5	6	6	6	6	† 6	† 6	† 6
F2	2	To shell-aft peaks of high power, fine form vessels	-	-	6	6	5	6	6	6	6	6	5	-
F2	7	To shell-aft peaks of high power, fine form vessels	-	-	6	6	5	6	6	6	6	6	5	-
F2	35	To shell-aft peaks of high power, fine form vessels	-	-	6	6	5	6	6	6	6	5 ⁶	5	-
F3	22	To inner bottom-clear of engine-nontight	-	6	6	6	5	6	6	5	5	5	5	-
F3	26	To shell-flat of bottom forward (fore end strengthening)	-	6	6	6	5	6	6	5	5	5	5	-
F3	28	To inner bottom in way of engines	-	6	6	6	5	6	6	5	5	5	5	-
G1	49	To shell and to bulkheads and decks in way of tanks	-	8	9	9	8	9	9	8	7	7	6	6
H1	50	To decks and bulkheads clear of tanks	-	9	10	10	9	10	10	9	8	8	7	7
J1	54	Swash bulkhead-periphery (Same as G1)	-	8	9	9	8	9	9	8	7	7	6	6

B-10

486-330

92

907

Leg Size for Lesser Thickness of Members Joined, In.

		Leg Size for Lesser Thickness of Members Joined, In.												
		0.20	0.24	0.28	0.32	0.36	0.40	0.44	0.48	0.52	0.56	0.60	0.64	
ABS Weld Grp.	Ln. No.	Nominal leg size of fillet	3/16	3/16	1/4	1/4	1/4	5/16	5/16	5/16	5/16	5/16	5/16	
		Length of fillet weld	2-1/8	2-1/2	3	3	3	3	3	3	3	3	3	
		Structural Items	Spacing of Welds S, in.											
K1	19	To center vertical keel	*10	*10	10	10	9	10	10	9	8	8	7	7
K2	15	To inner bottom at forward end (fore end strengthening)	*11	*11	11	11	10	11	11	10	9	9	8	8
K3	16	To inner bottom-elsewhere (See Note 5)	*12	*12	12	12	11	12	12	11	10	10	10	10
K3	18	Stiffeners	-	12	12	12	11	12	12	11	10	10	10	10
K3	25	Stiffeners	-	12	12	12	11	12	12	11	10	10	10	10
L1	41	To inner bottom (same as K3)	*12	*12	12	12	11	12	12	11	10	10	10	10
M1	10	To center vertical keel and side girders where floor is continuous	*10	⁹ *10	10	10	9	10	10	9	8	8	7	7
M1	53B	To face plate area 10 in. ²	-	-	10	10	9	10	10	9	8	8	7	7
M1	55	Non-tight structural bulkhead-periphery	-	9	10	10	9	10	10	9	8	8	7	7
M2	3	To shell-flat of bottom forward and in peaks	-	-	10	10	9	10	10	10	9	9	8	8
M2	8	To shell-flat of bottom forward and in peaks	-	-	10	10	9	10	10	10	9	9	8	8
M2	36	To shell for 0.125L forward	-	-	10	10	9	10	10	10	9	9	8	8
M2	37	To shell in peaks	-	-	10	10	9	10	10	10	9	9	8	8
M2	43	To shell for 0.125L forward	-	-	10	10	9	10	10	10	9	9	8	8
M2	44	To shell in peaks	-	-	10	10	9	10	10	10	9	9	8	8
M3	27	To shell-elsewhere	*11	*11	11	11	10	11	11	10	9	9	8	8
M3	29	To inner bottom-elsewhere	*11	*11	11	11	10	11	11	10	9	9	8	8
M3	31	To floors-elsewhere (Same as K2)	*11	*11	11	11	10	11	11	10	9	9	8	8

B-11

486-380-93

93

907

Leg Size for Lesser Thickness of Members Joined, In.

0.20 0.24 0.28 0.32 0.36 0.40 0.44 0.48 0.52 0.56 0.60 0.64

Nominal leg size of fillet 3/16 3/16 1/4 1/4 1/4 5/16 5/16 5/16 5/16 5/16 5/16 5/16

Length of fillet weld 2-1/8 2-1/2 3 3 3 3 3 3 3 3 3 3

Spacing of welds S, In.

3 3 3

To shell-elsewhere *12 *12 12 12 11 12 12 12 11 10 10 10

To face plate *12 *12 12 12 11 12 12 12 11 10 10 10

To shell-elsewhere (See Note 5) *12 *12 12 12 11 12 12 12 11 10 10 10

Stiffeners 12 12 12 12 11 12 12 12 11 10 10 10

To shell-elsewhere (See Note 1) *12 *12 12 12 11 12 12 12 11 10 10 10

To shell-elsewhere *12 *12 12 12 11 12 12 12 11 10 10 10

To inner bottom *12 12 12 12 11 12 12 12 11 10 10 10

To face plate 10 in.² *10- 12 12 11 12 12 12 11 10 10 10 10

To deep tank bulkheads (See Note 1) - *12 12 12 11 12 12 12 11 10 10 10 10

To watertight bulkheads and superstructure or deckhouse front-bulkheads (See Note 1) - *12 12 12 11 12 12 12 11 10 10 10 10

To decks, except slab longitudinals *12 *12 12 12 11 12 12 12 11 10 10 10

To plating and to face plate (See Note 4) *12 *12 12 12 11 12 12 12 11 10 10 10

To non-tight structural bulkhead (See Note 2) *12 *12 12 12 12 12 12 12 12 12 12 10 10

To deckhouse side and superstructure end bulkheads (See Note 2) *12 *12 12 12 12 12 12 12 12 12 12 10 10

ADDITIONAL WELDING REQUIREMENTS FOR VESSELS CLASSED "HULL CARRIERS"

To face bars - - - 6 6 6 6 6 5 5 5 - -

To face bars - - - 6 6 6 6 6 5 5 5 - -

APPENDIX C

PLOTS OF ABS AND PROPOSED FILLET WELD SIZES

C-1

486-330 - 95

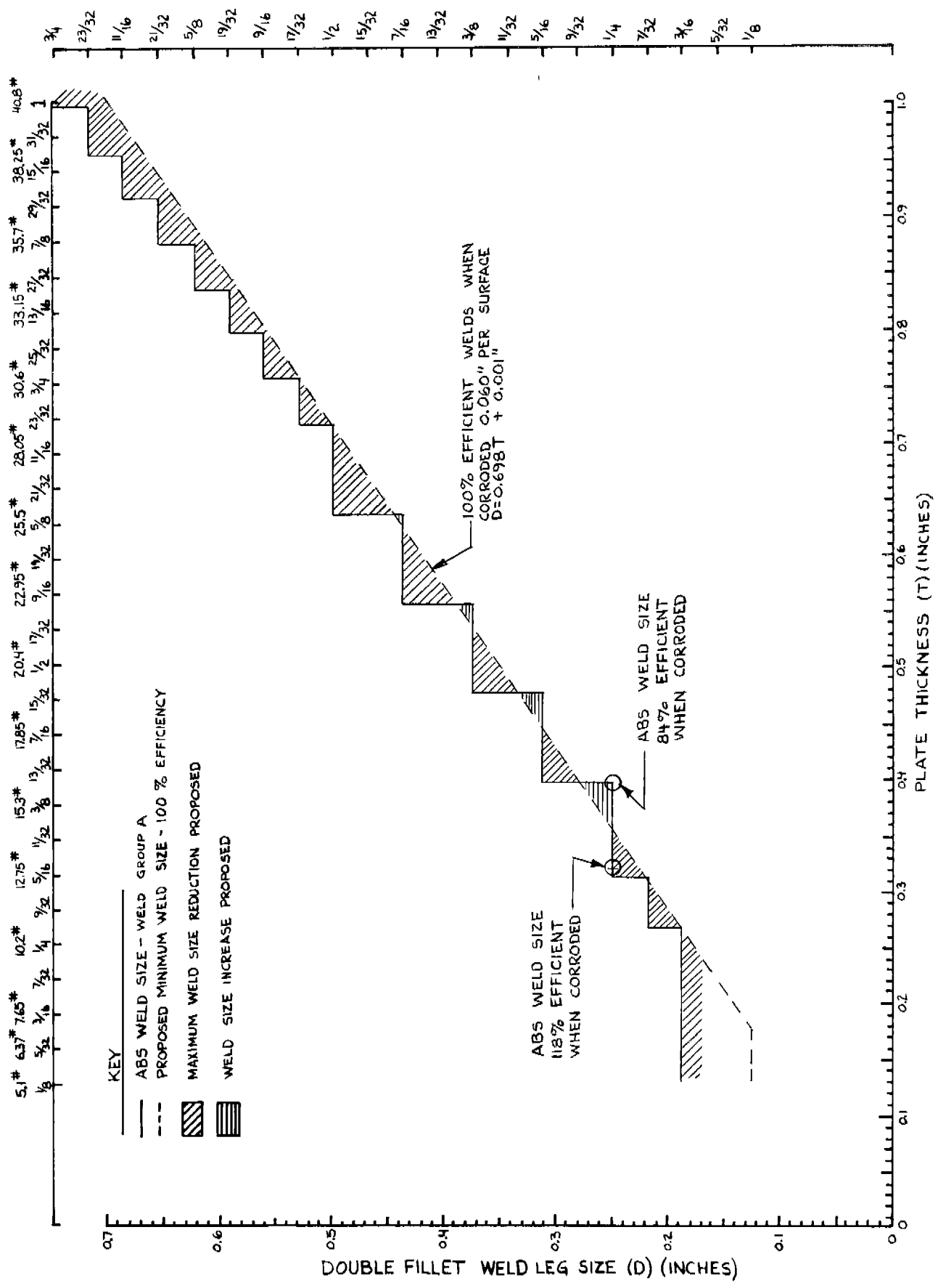

ABS WELD GROUP A

486-330

96

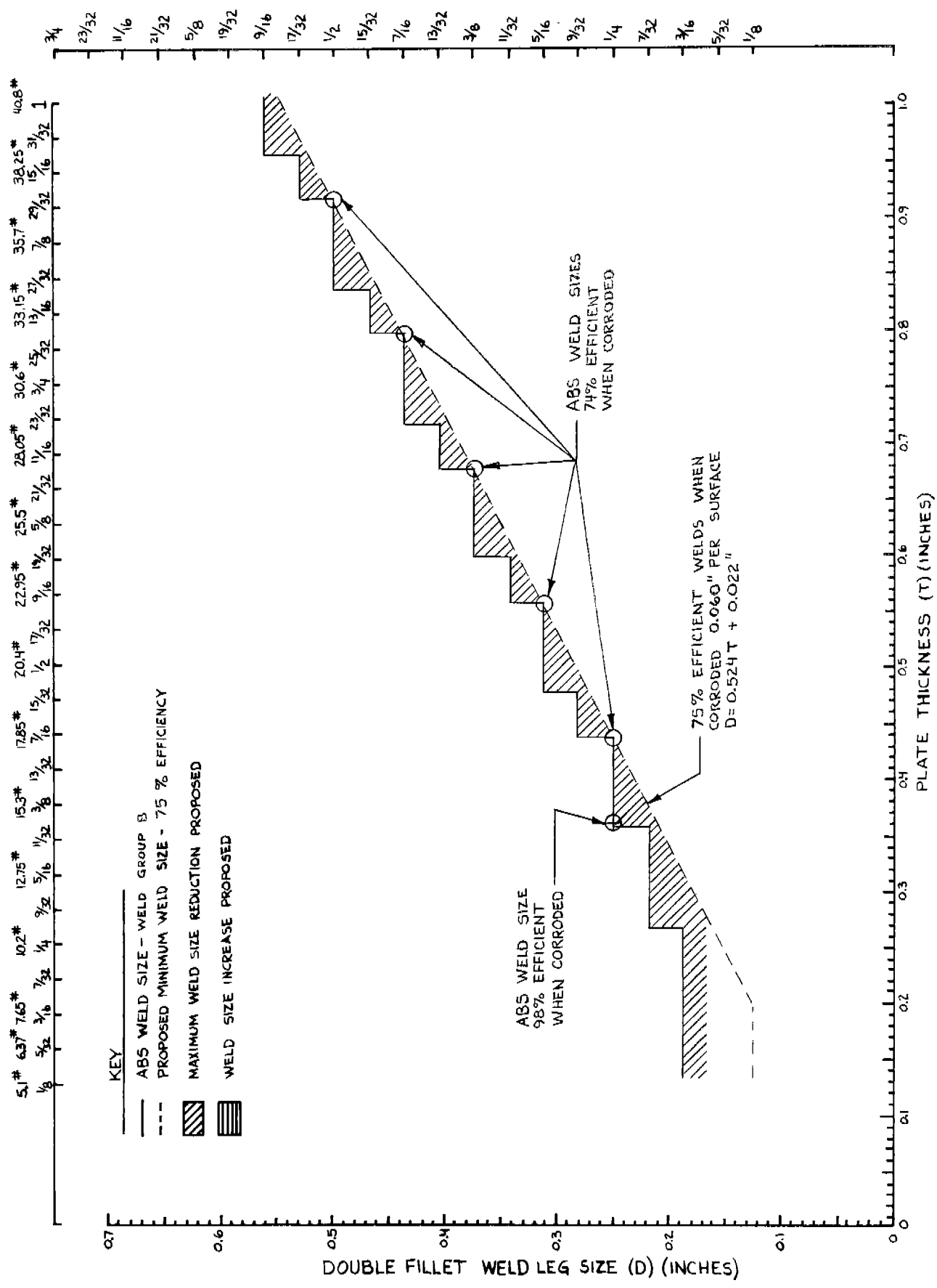

5.1*	6.37*	7.65*	10.2*	12.75*	15.3*	17.85*	20.4*	22.95*	25.5*	28.05*	30.6*	33.15*	35.7*	38.25*	40.8*
1/8	3/32	1/4	5/32	1/2	3/8	7/16	1/2	9/16	5/8	11/16	3/4	13/16	7/8	15/16	1

486-330

ABS WELD GROUP B

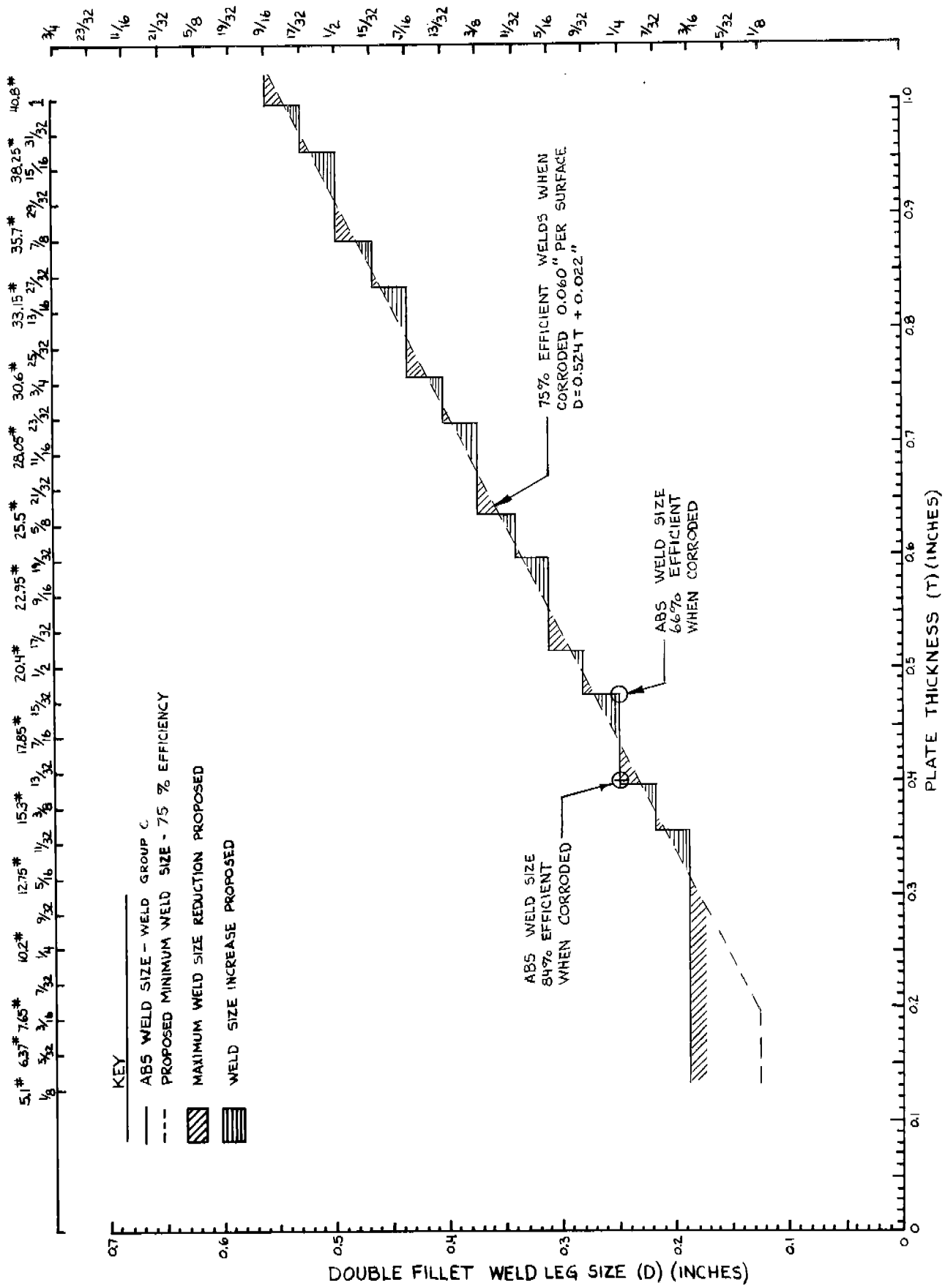

486-330

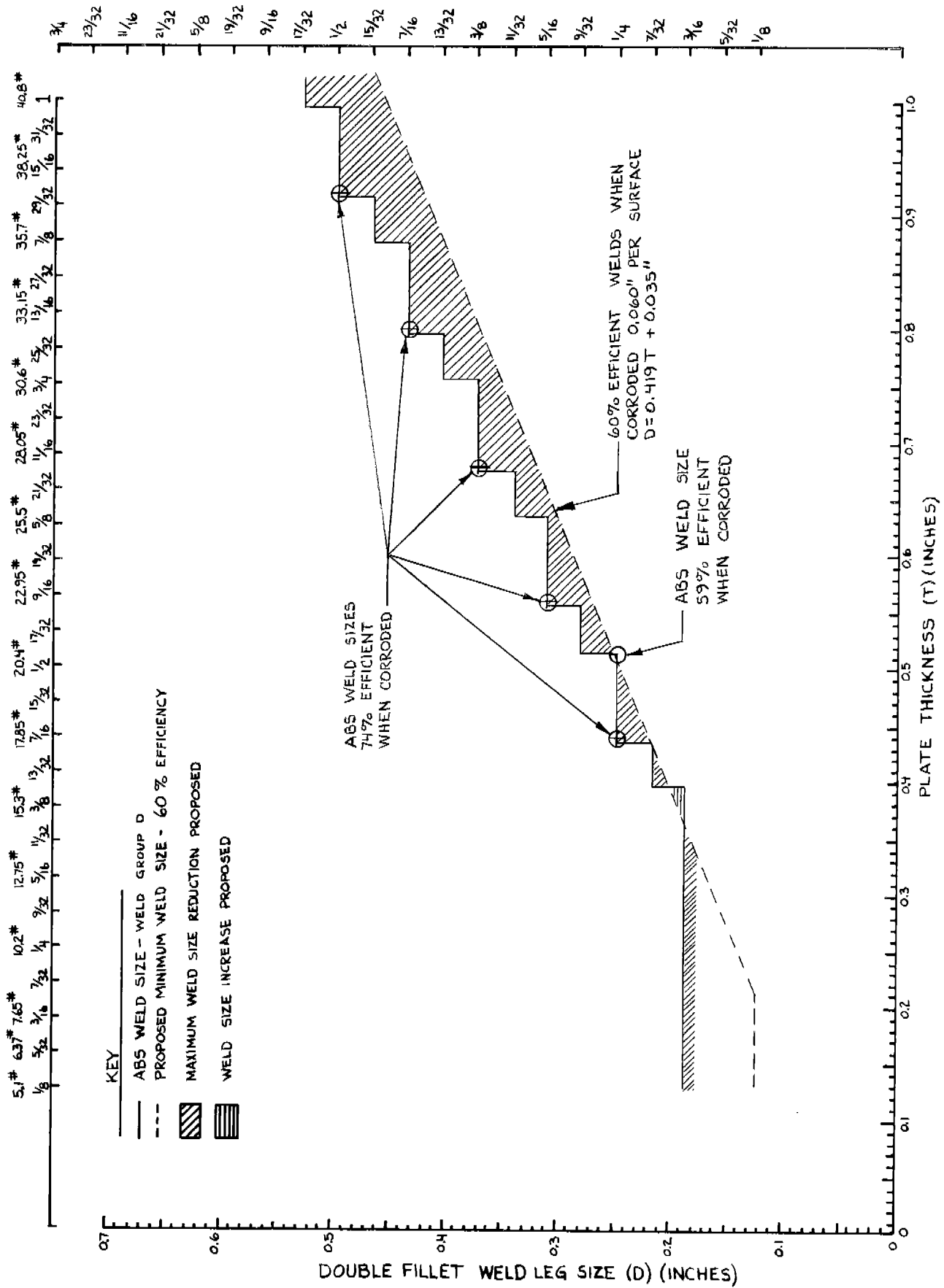

ABS WELD GROUP D

486-330

C-6

ABS WELD GROUP E

100

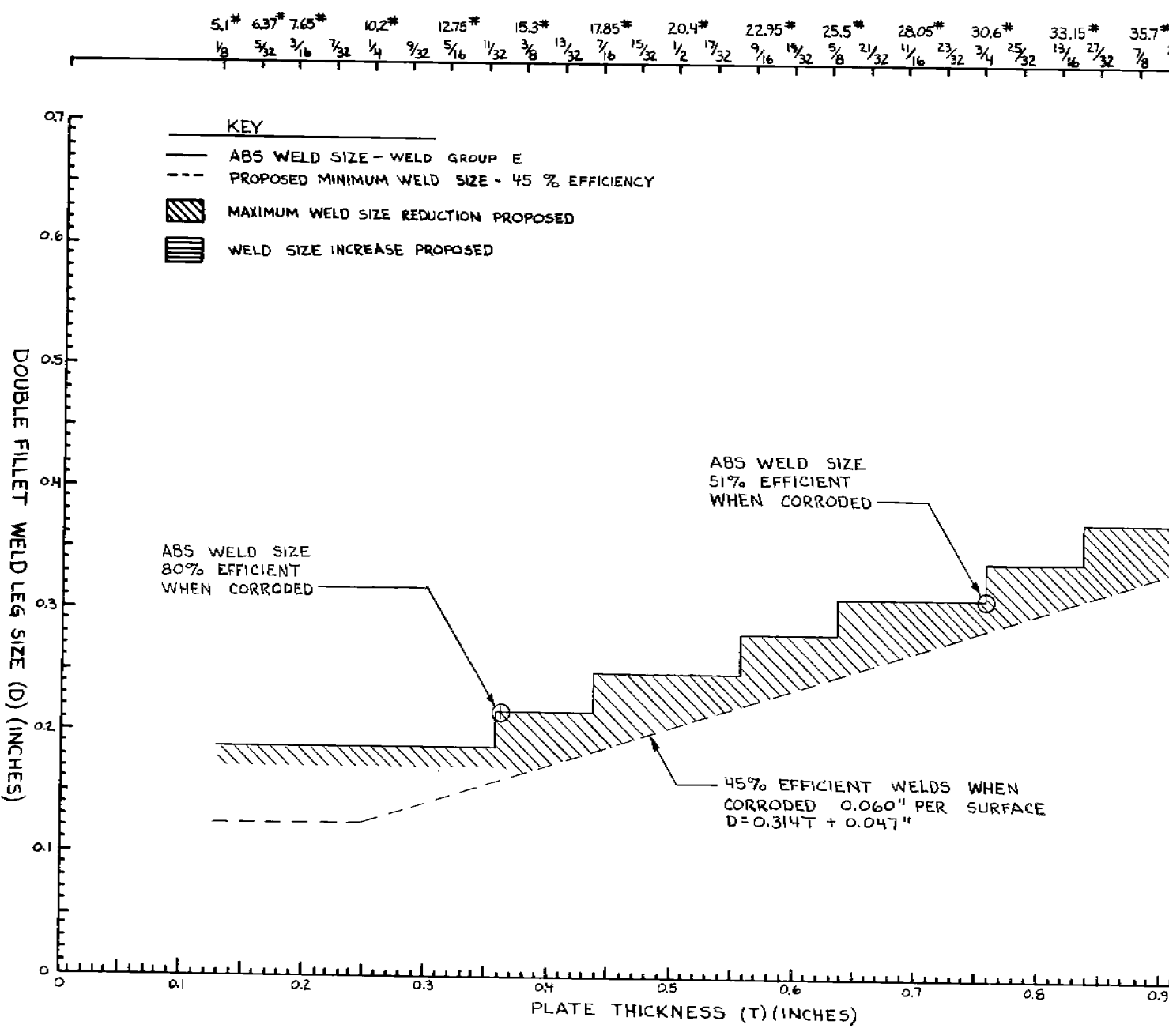

5.1* 6.37* 7.65* 10.2* 12.75* 15.3* 17.85* 20.4* 22.95* 25.5* 28.05* 30.6* 33.15* 35.7*

1/8 5/32 3/16 7/32 1/4 9/32 5/16 11/32 3/8 13/32 7/16 15/32 1/2 17/32 9/16 19/32 5/8 21/32 11/16 23/32 3/4 25/32 13/16 27/32 7/8

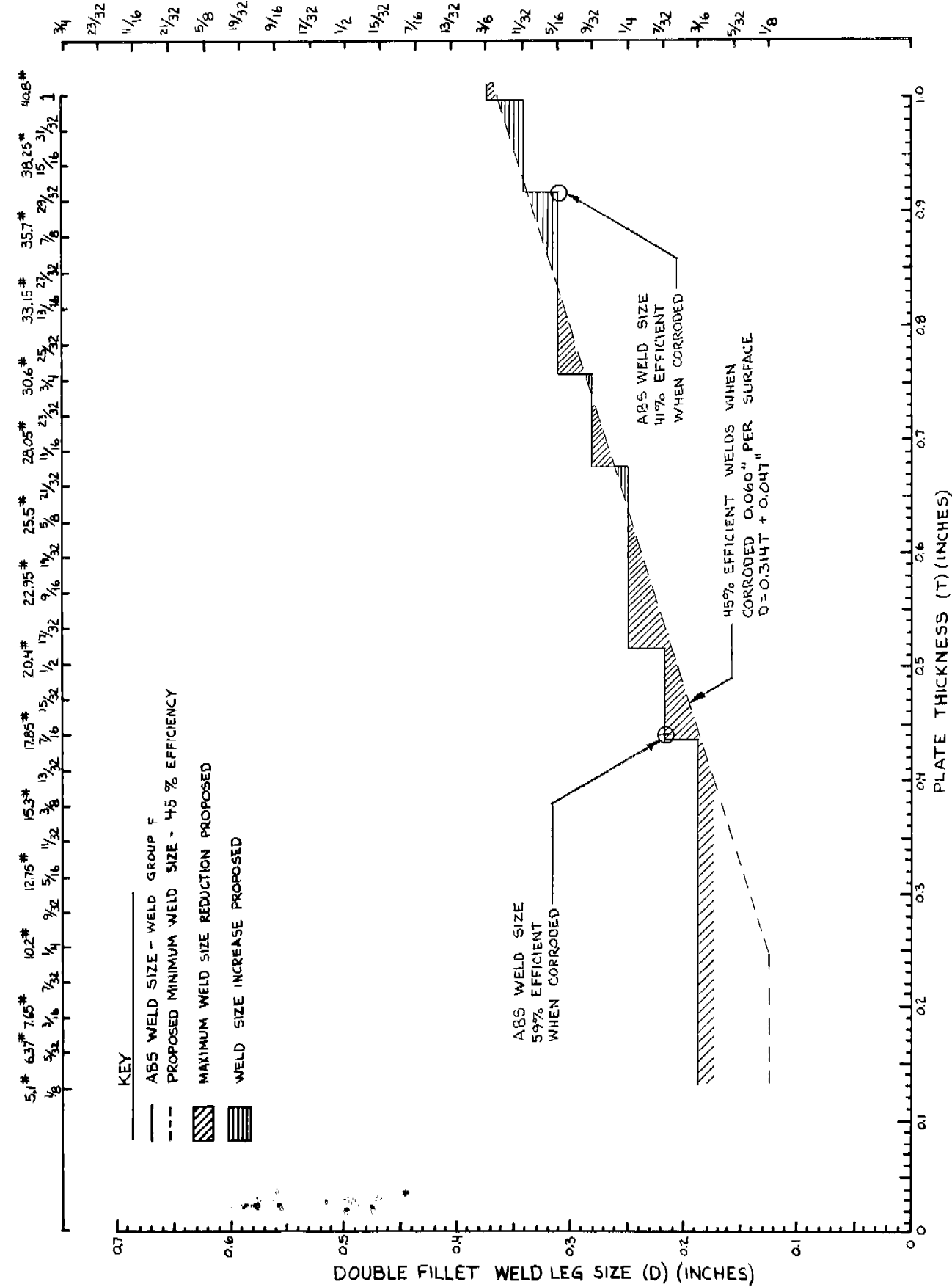

486-330

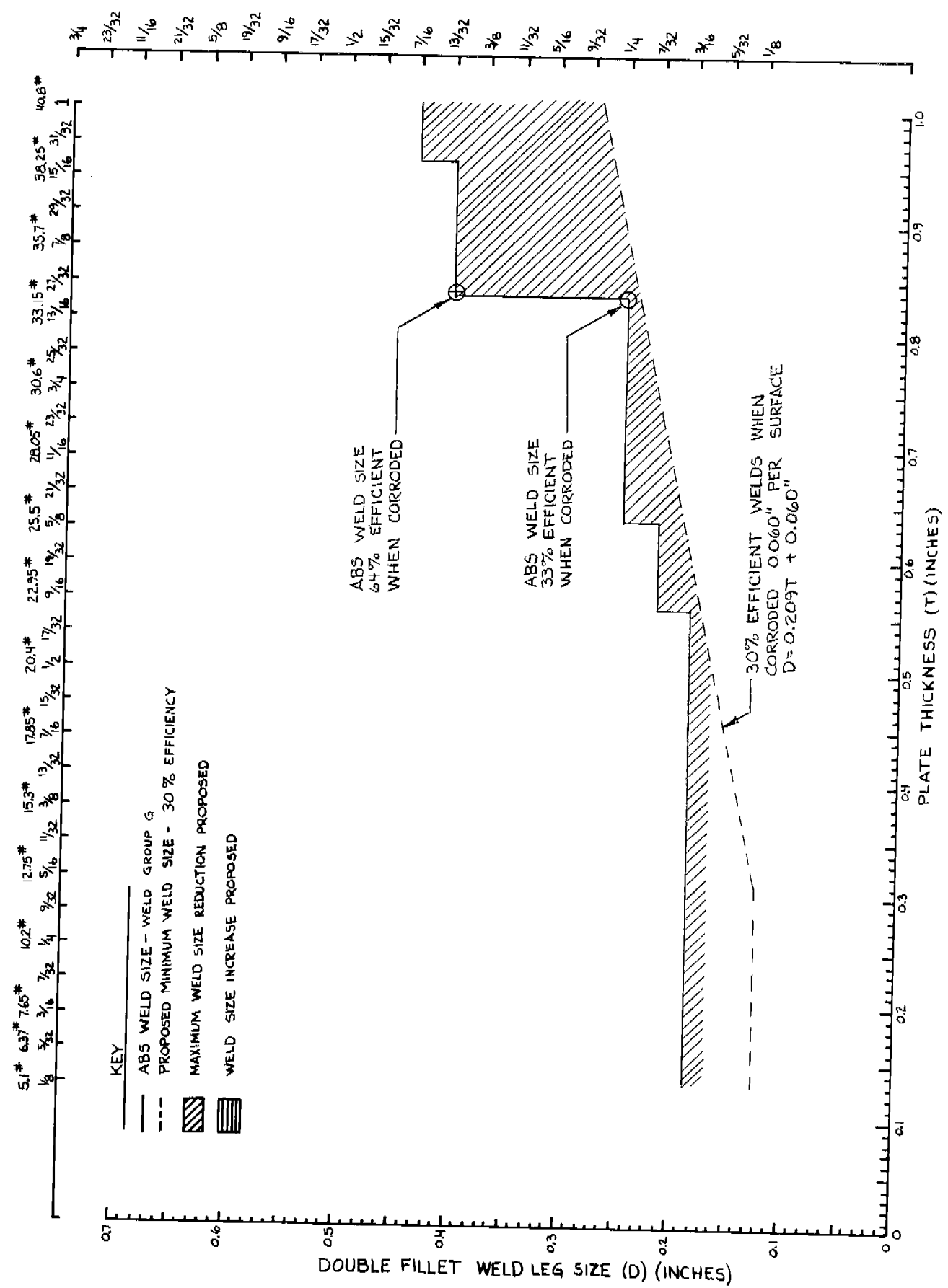

DOUBLE FILLET WELD LEG SIZE (D) (INCHES)

ABS WELD GROUP G

486-330

102

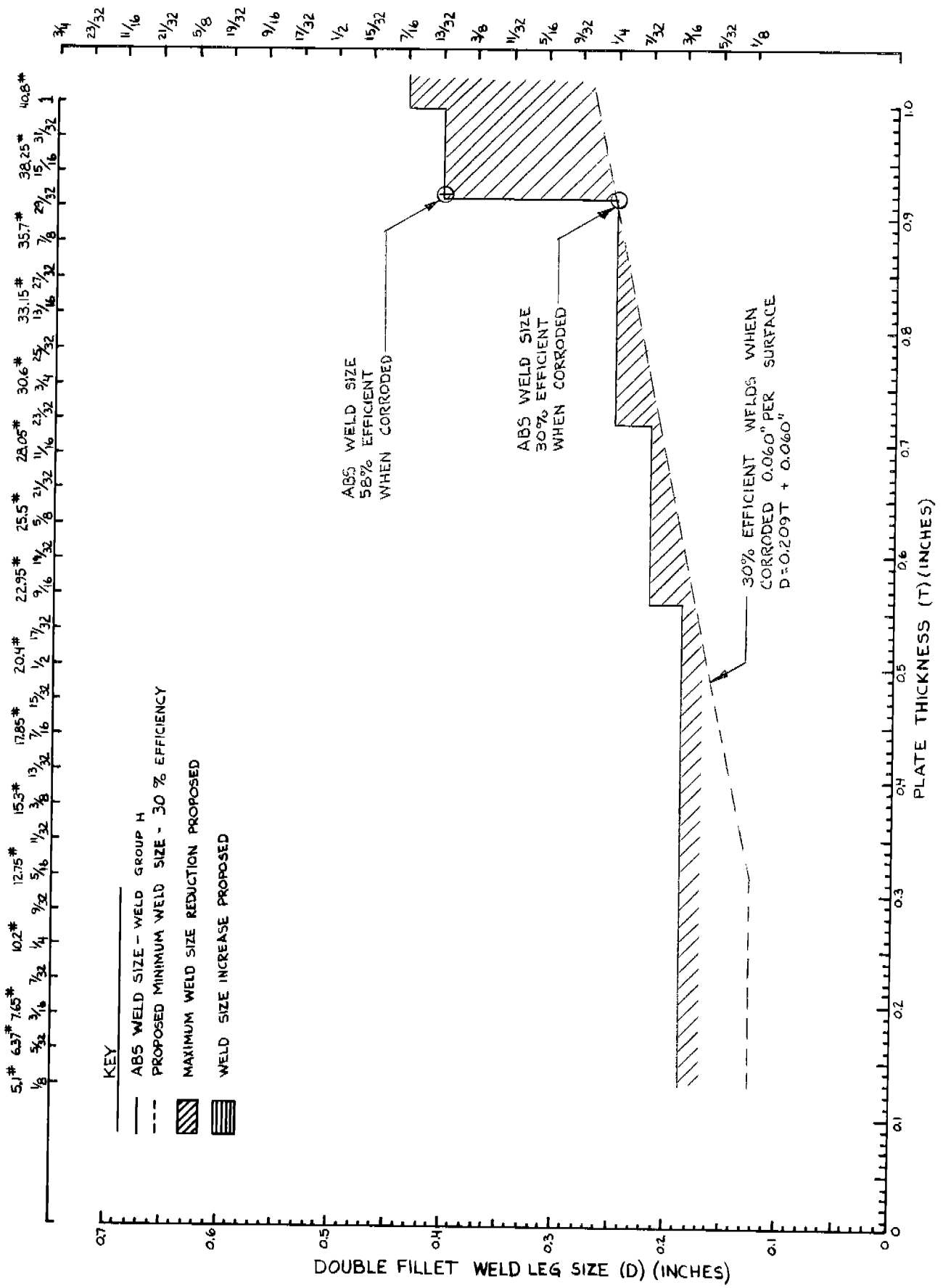

ABS WELD GROUP H

486-330

103

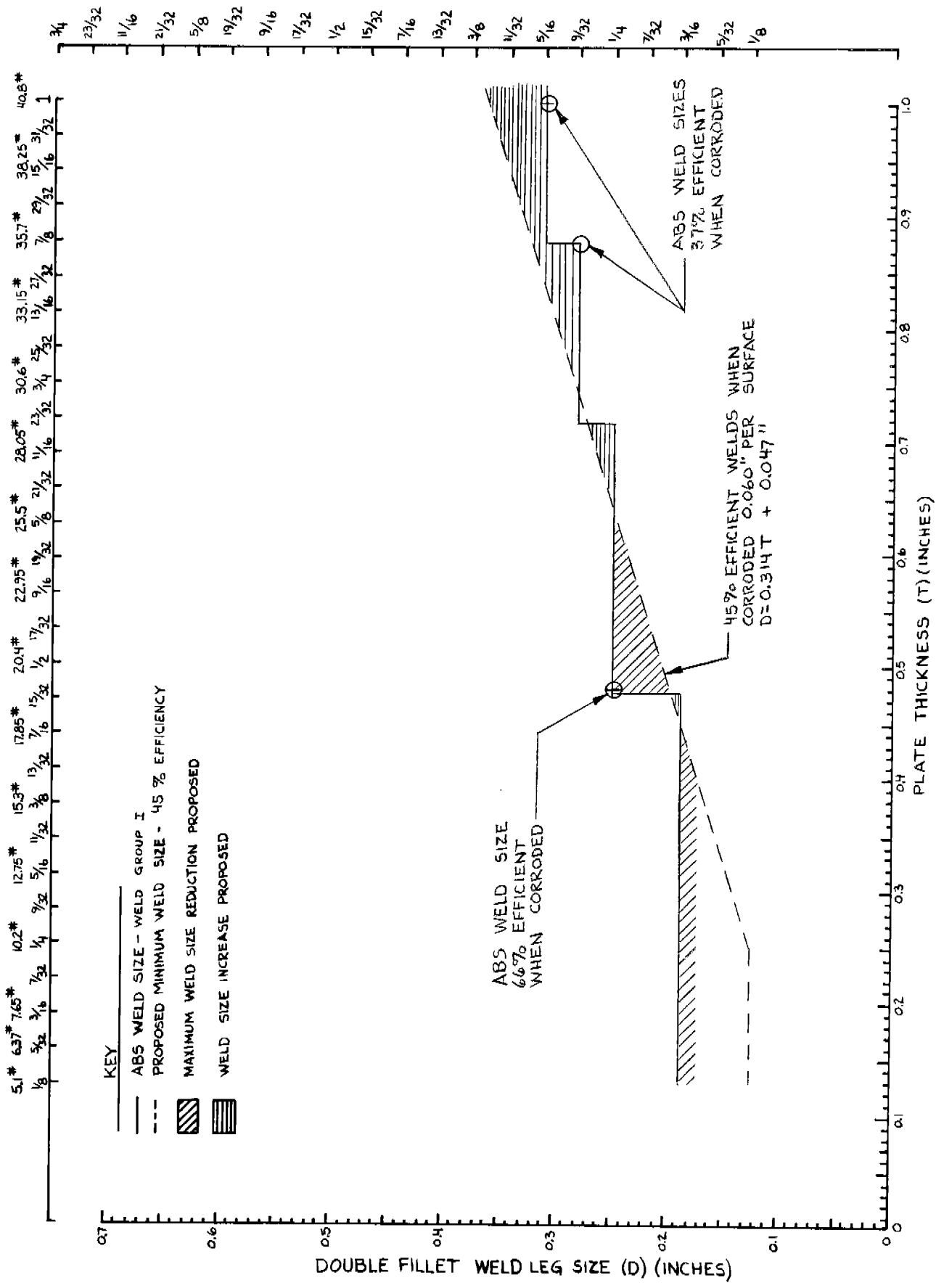

486-330

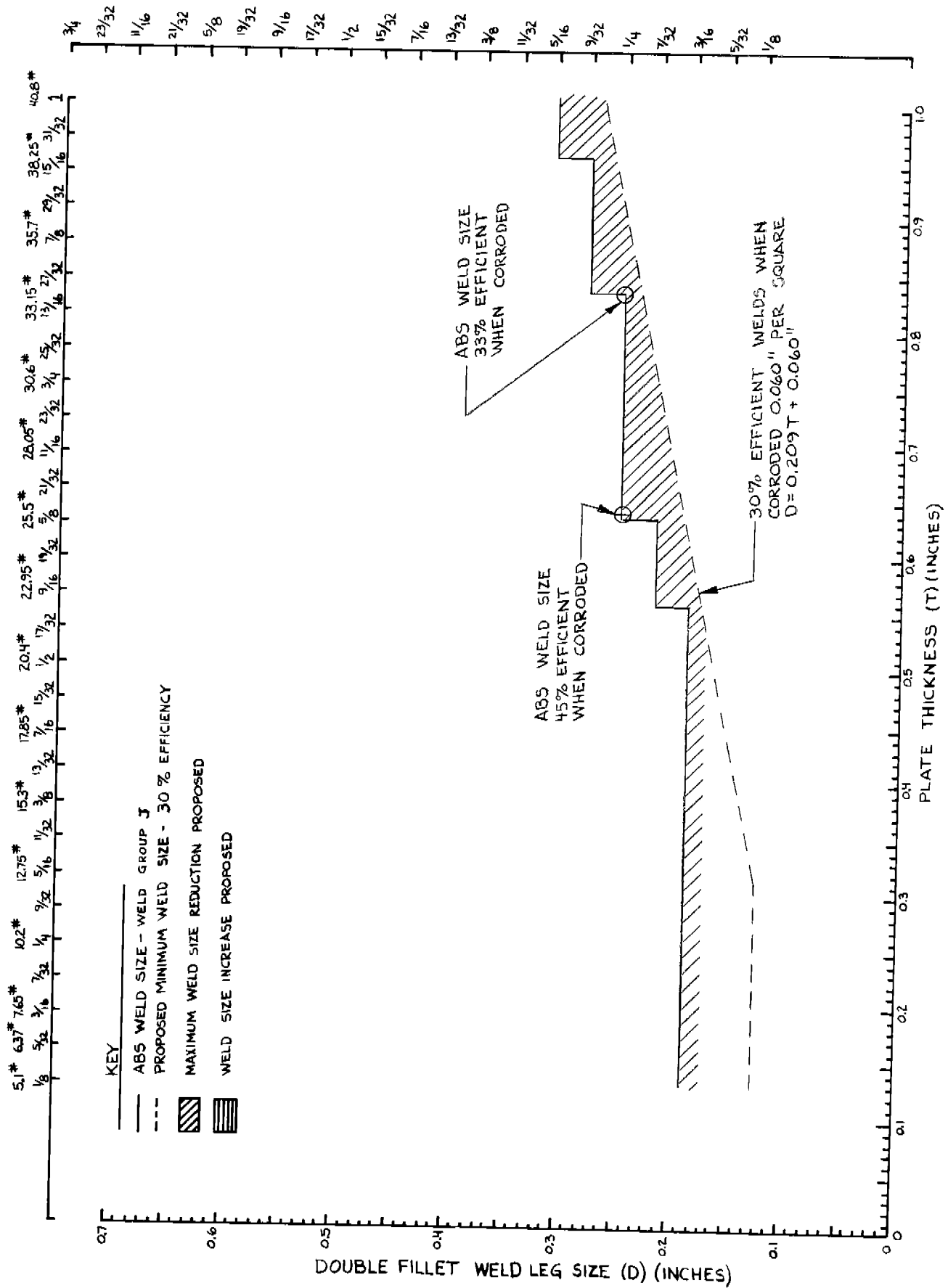

486-330

105

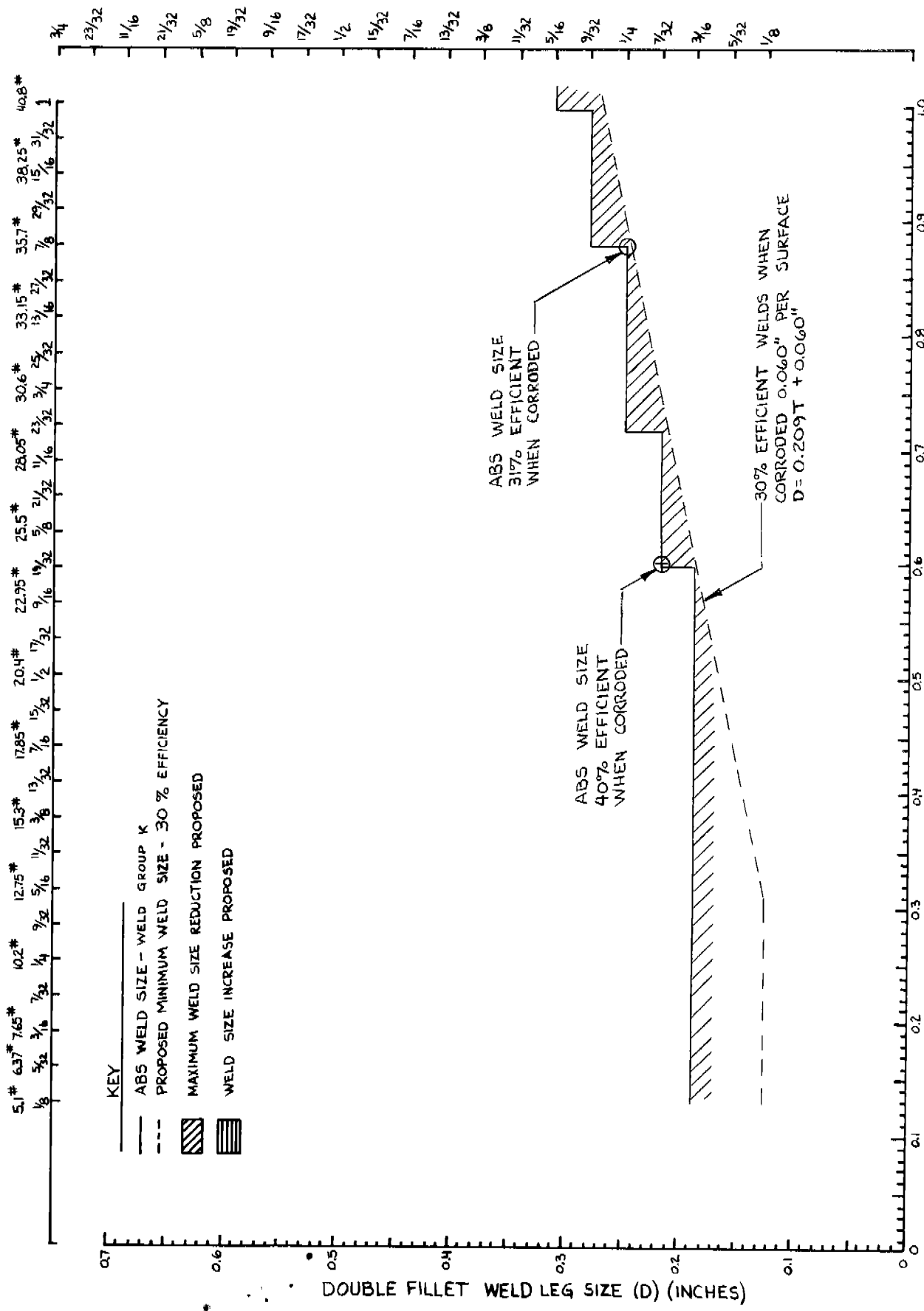

486-330

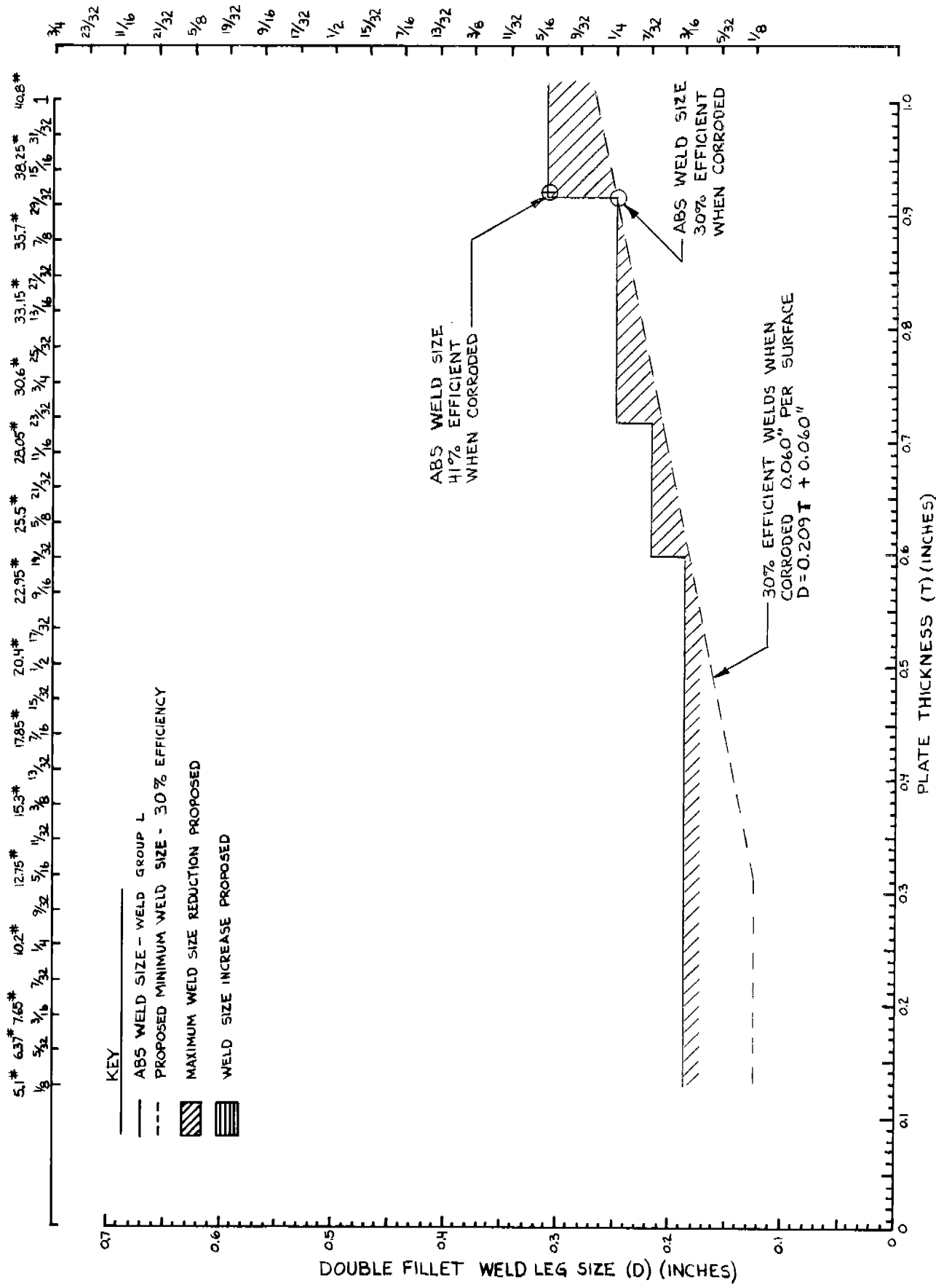

ABS WELD GROUP L

486-330

107

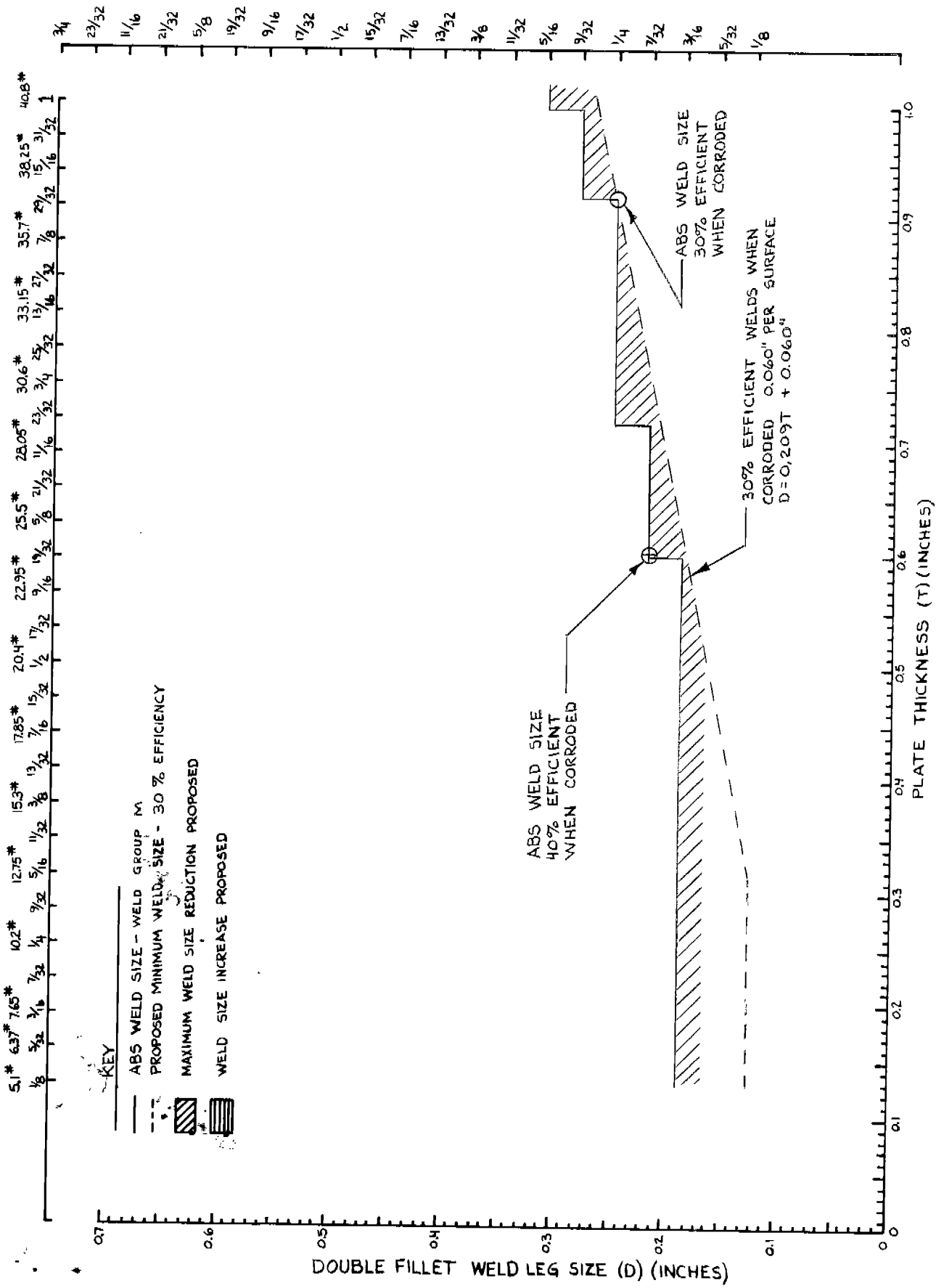

486-330

108

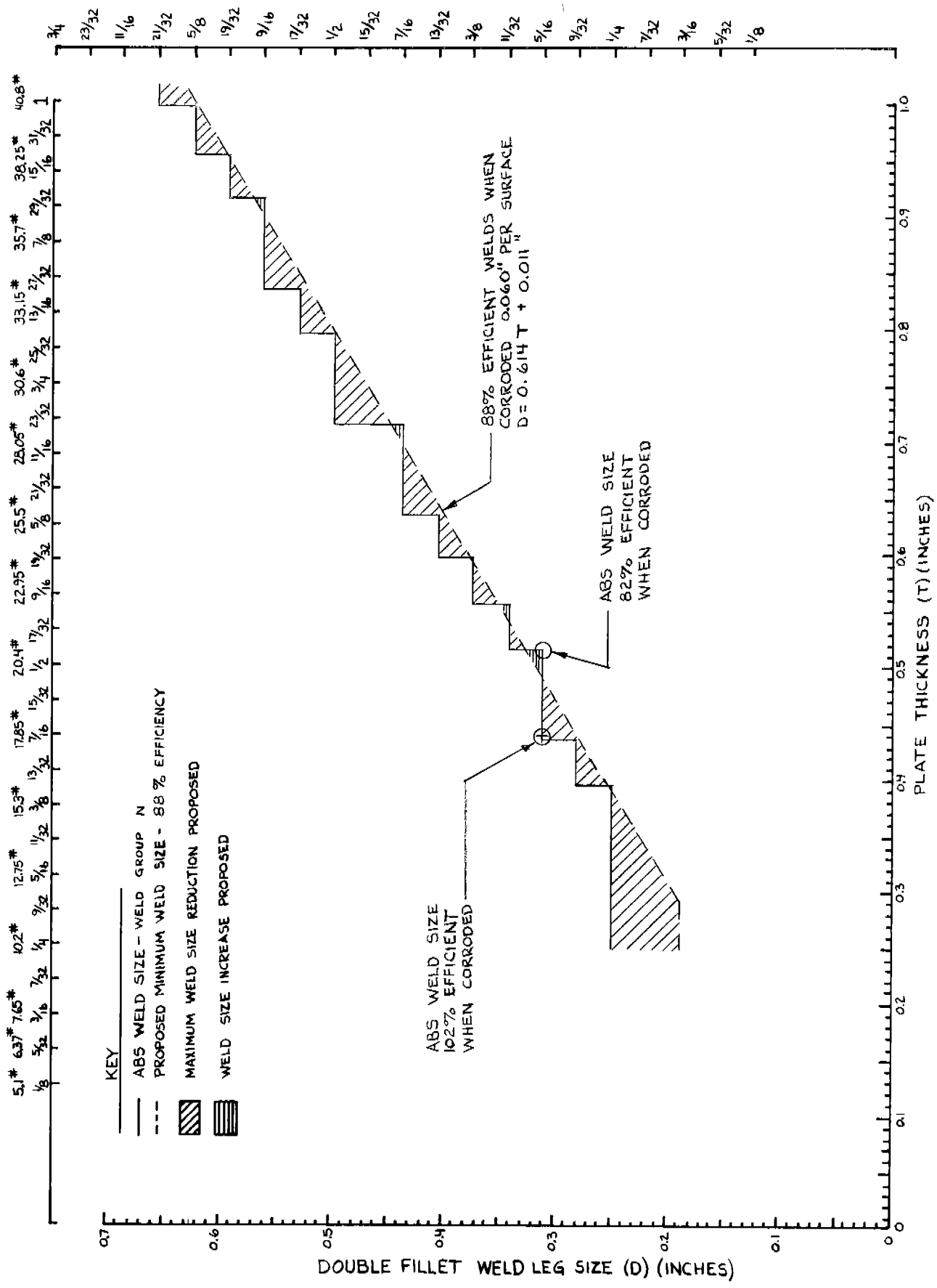

486-330

ABS WELD GROUP N

C-15

109

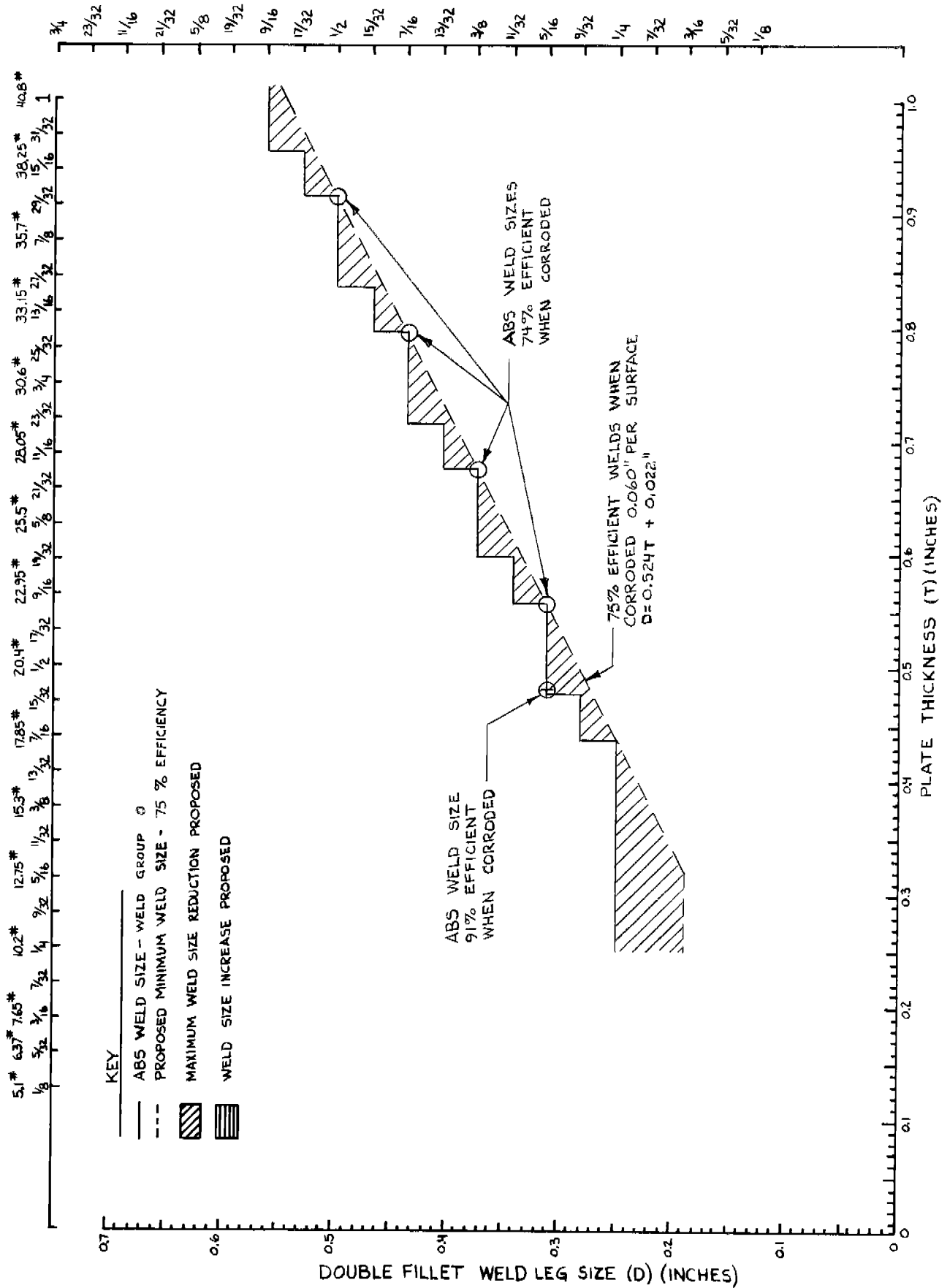

ABS WELD GROUP O

486-330

110

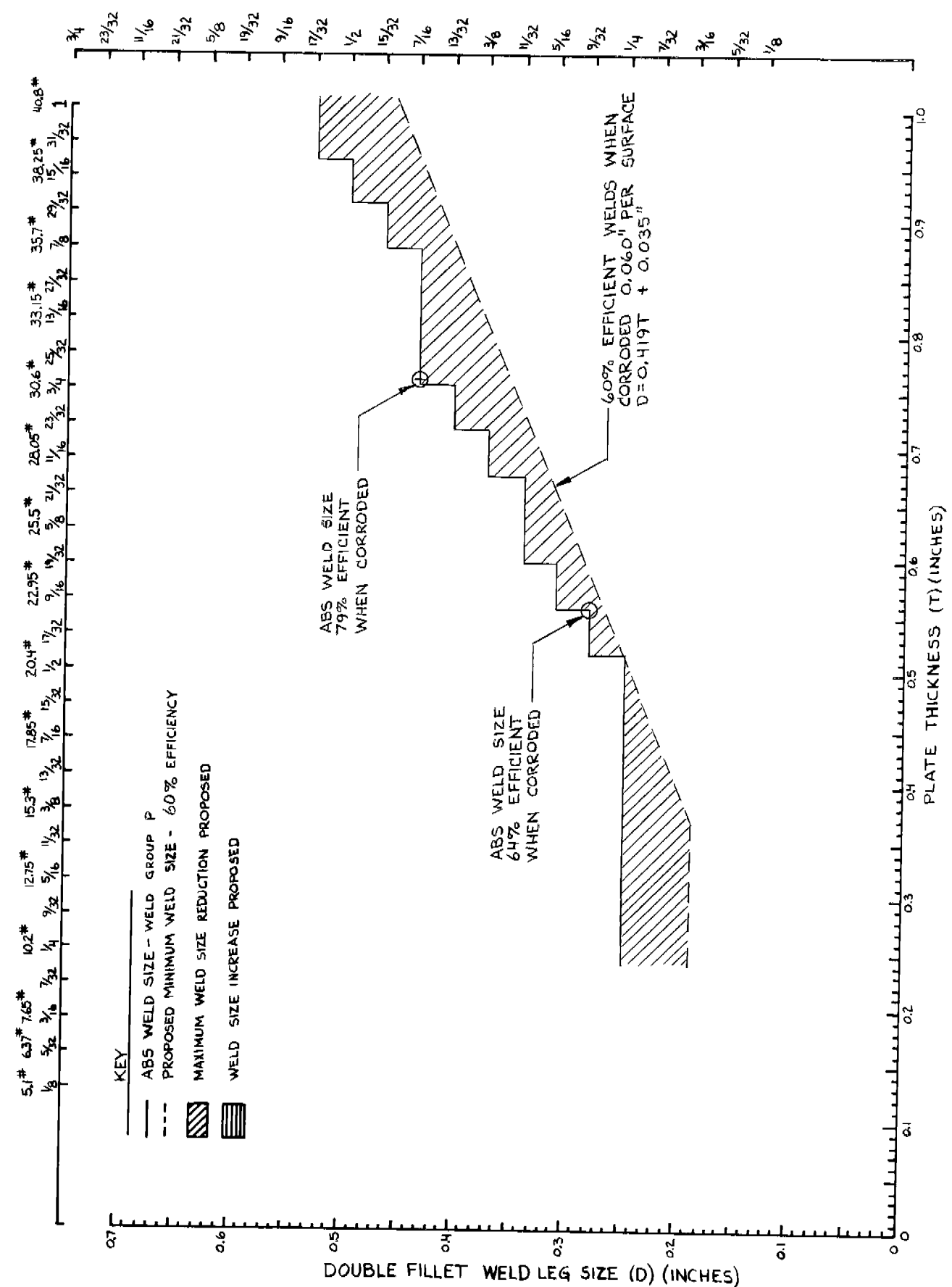

ABS WELD GROUP P

486-330

111

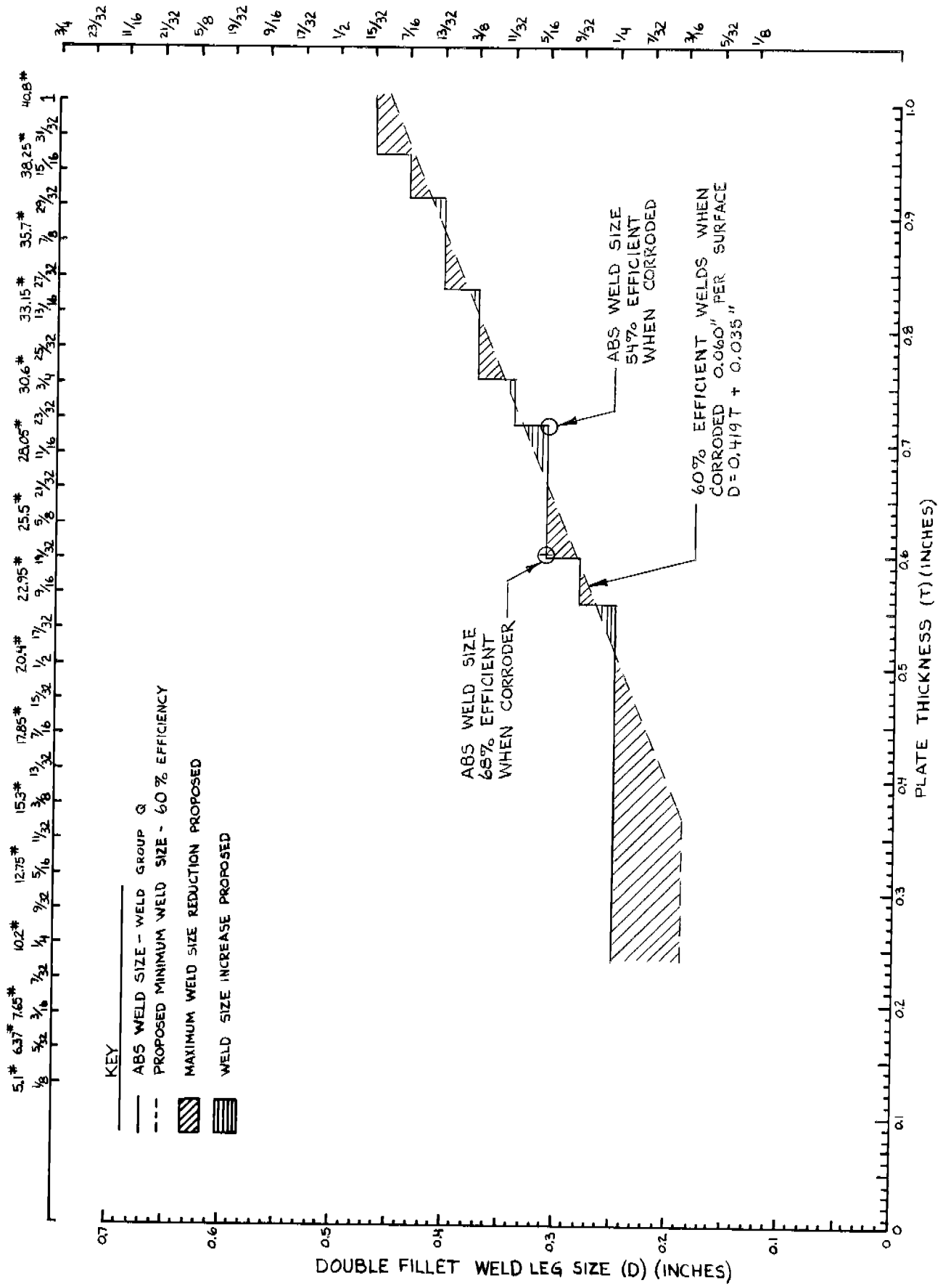

486-330

112

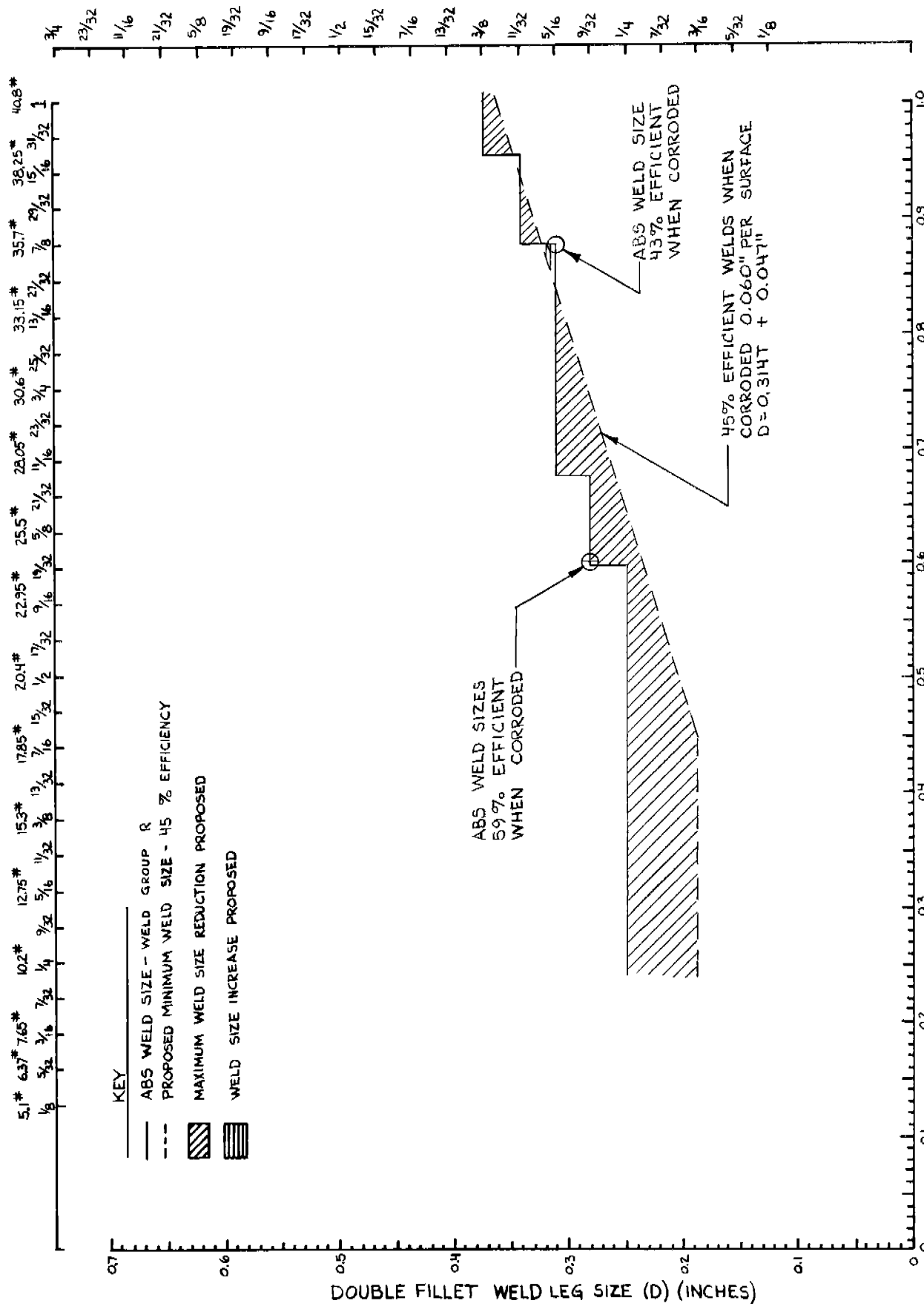

486-330

113

486-330

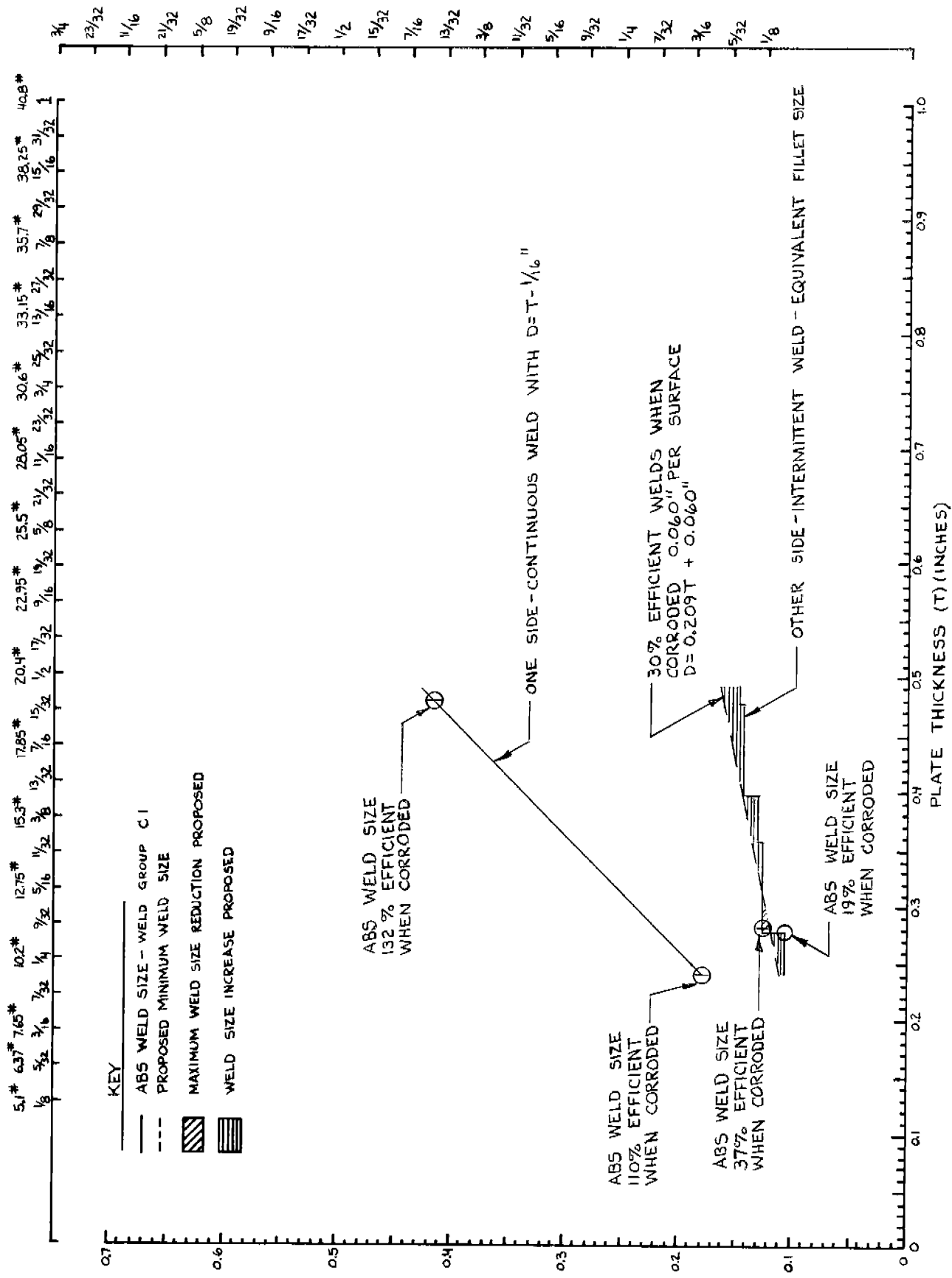

114

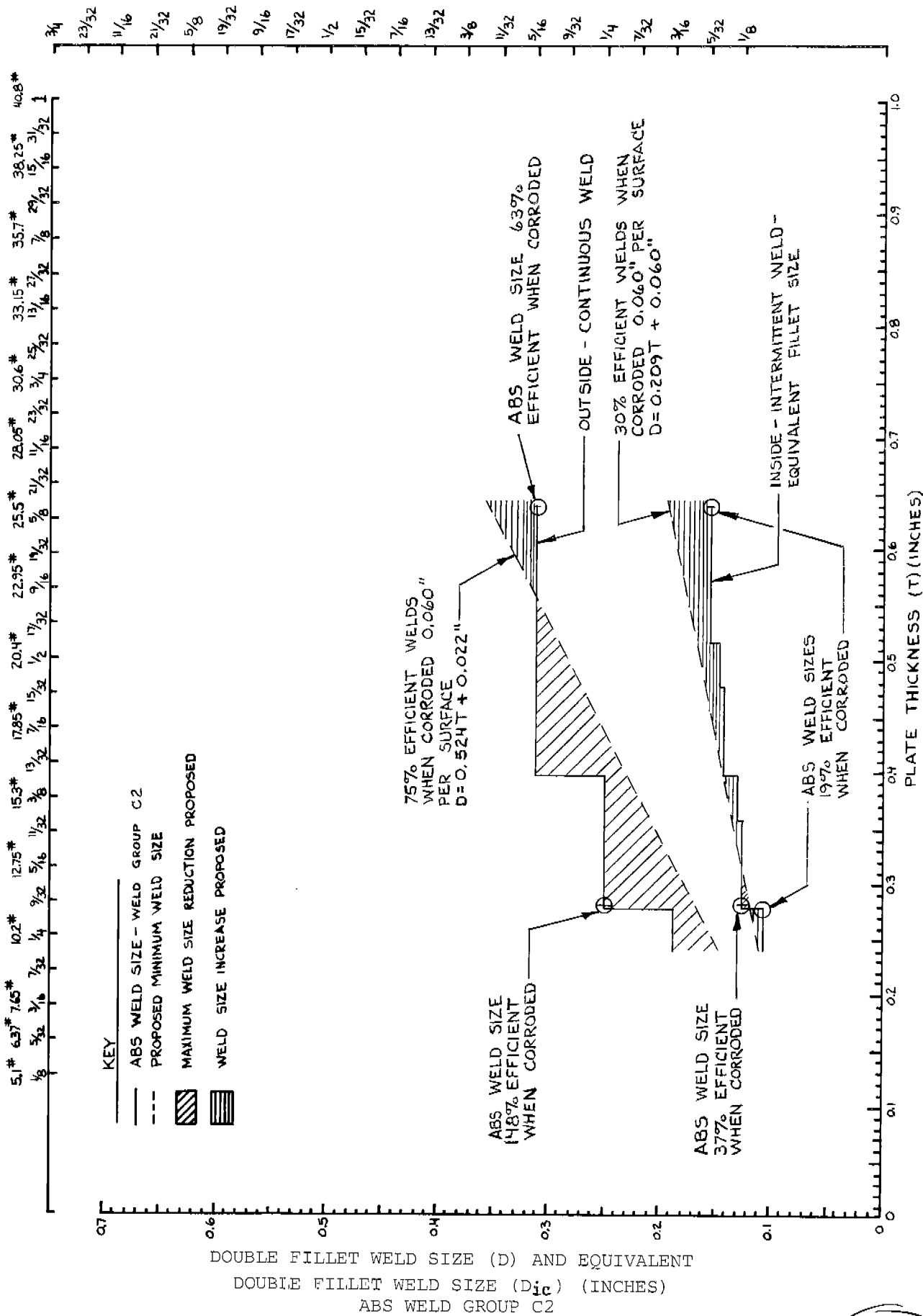

DOUBLE FILLET WELD SIZE (D) AND EQUIVALENT
 DOUBLE FILLET WELD SIZE (D_{ic}) (INCHES)
 ABS WELD GROUP C2

486-330

115

486-330

ABS WELD GROUP F1

C-22

1/16

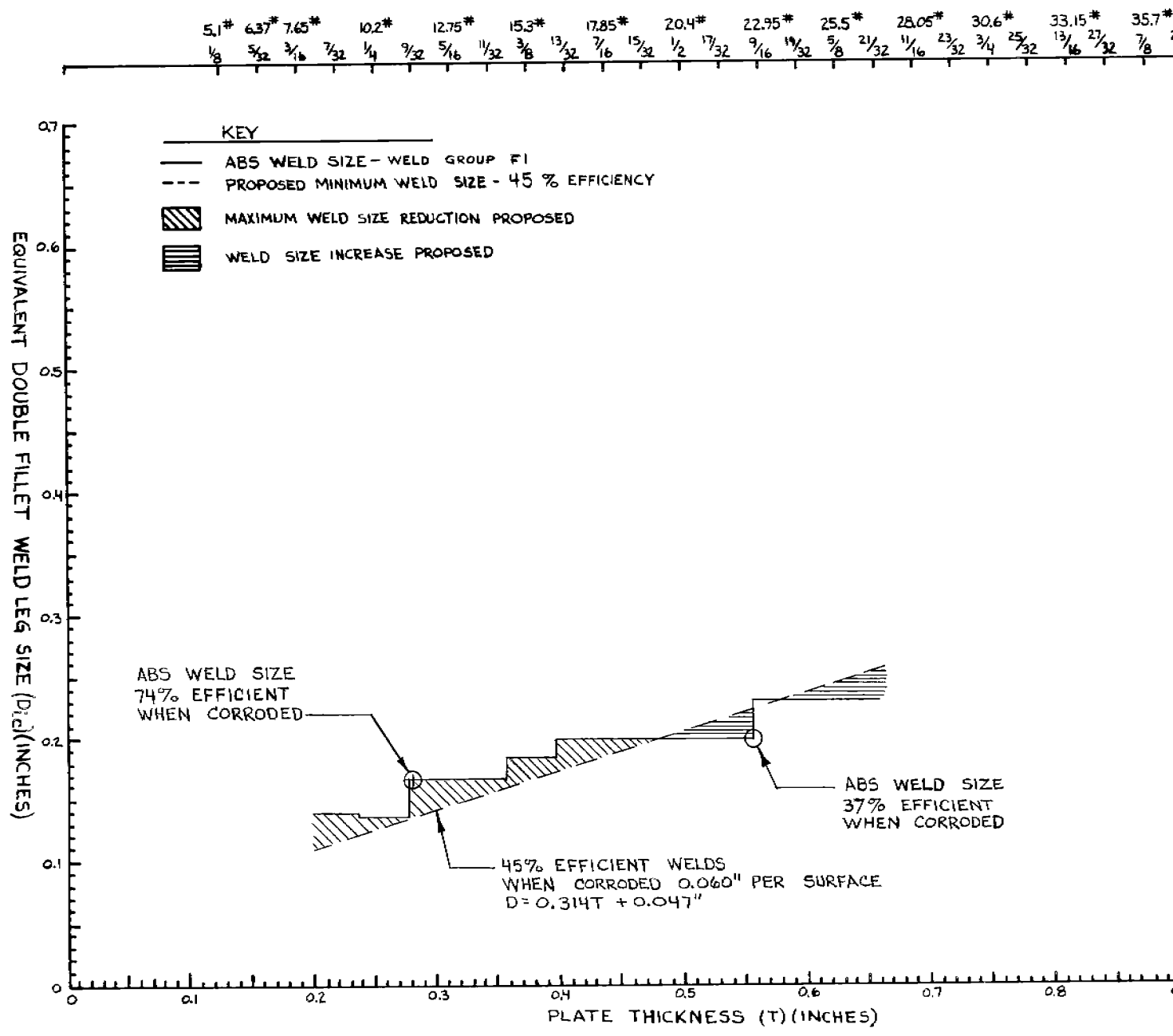

486-330

5.1* 6.37* 7.65* 10.2* 12.75* 15.3* 17.85* 20.4* 22.95* 25.5* 28.05* 30.6* 33.15* 35.7*

1/8 5/32 3/16 7/32 1/4 9/32 5/16 11/32 3/8 13/32 7/16 15/32 1/2 17/32 9/16 19/32 5/8 21/32 11/16 23/32 3/4 25/32 13/16 27/32 7/8 2

EQUIVALENT DOUBLE FILLET WELD LEG SIZE (D₂) (INCHES)

- KEY
- ABS WELD SIZE - WELD GROUP F2
 - - - PROPOSED MINIMUM WELD SIZE - 45% EFFICIENCY
 - ▨ MAXIMUM WELD SIZE REDUCTION PROPOSED
 - ▧ WELD SIZE INCREASE PROPOSED

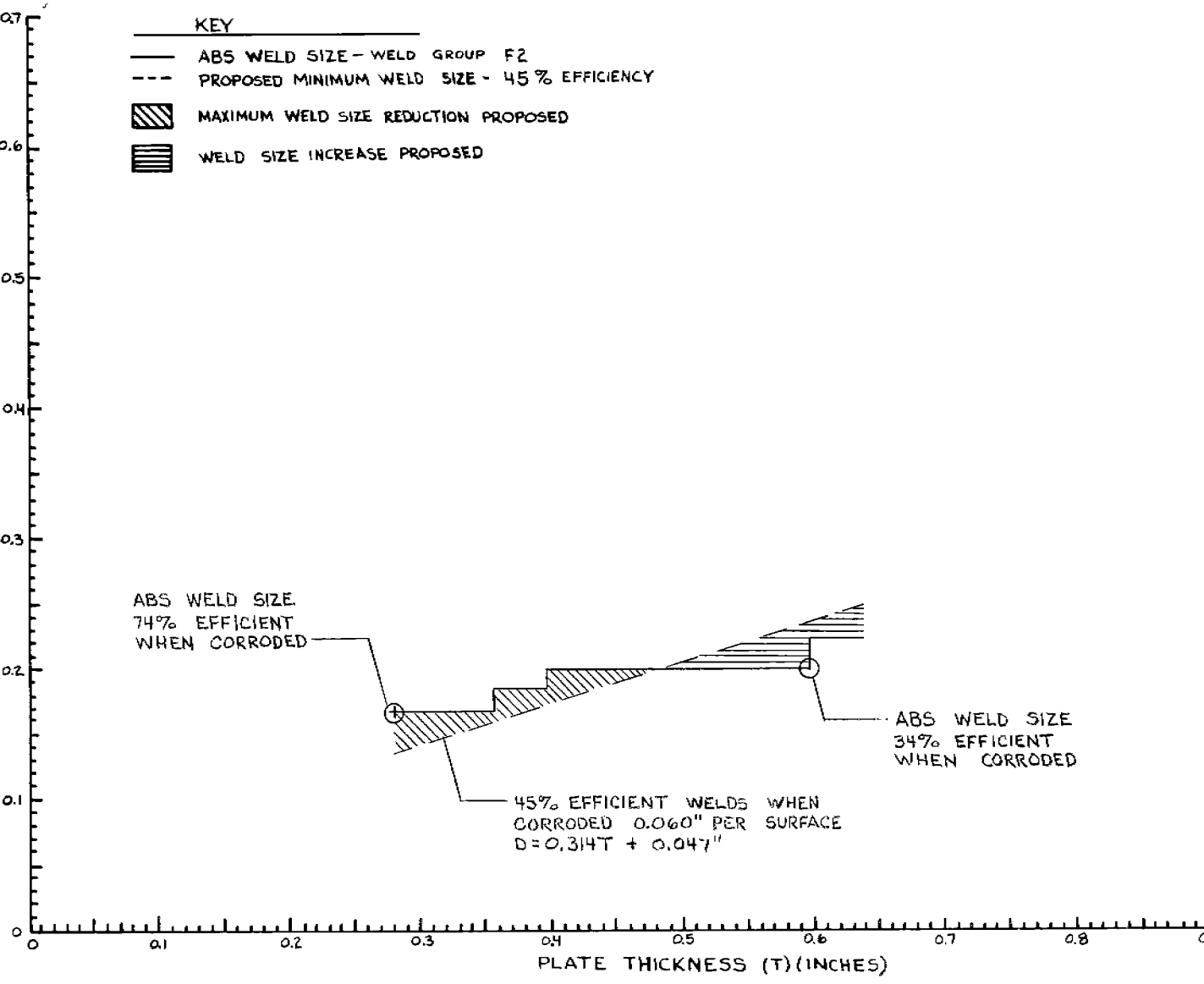

ABS WELD SIZE
74% EFFICIENT
WHEN CORRODED

ABS WELD SIZE
34% EFFICIENT
WHEN CORRODED

45% EFFICIENT WELDS WHEN
CORRODED 0.060" PER SURFACE
 $D = 0.314T + 0.047"$

ABS WELD GROUP F2

C-23

117

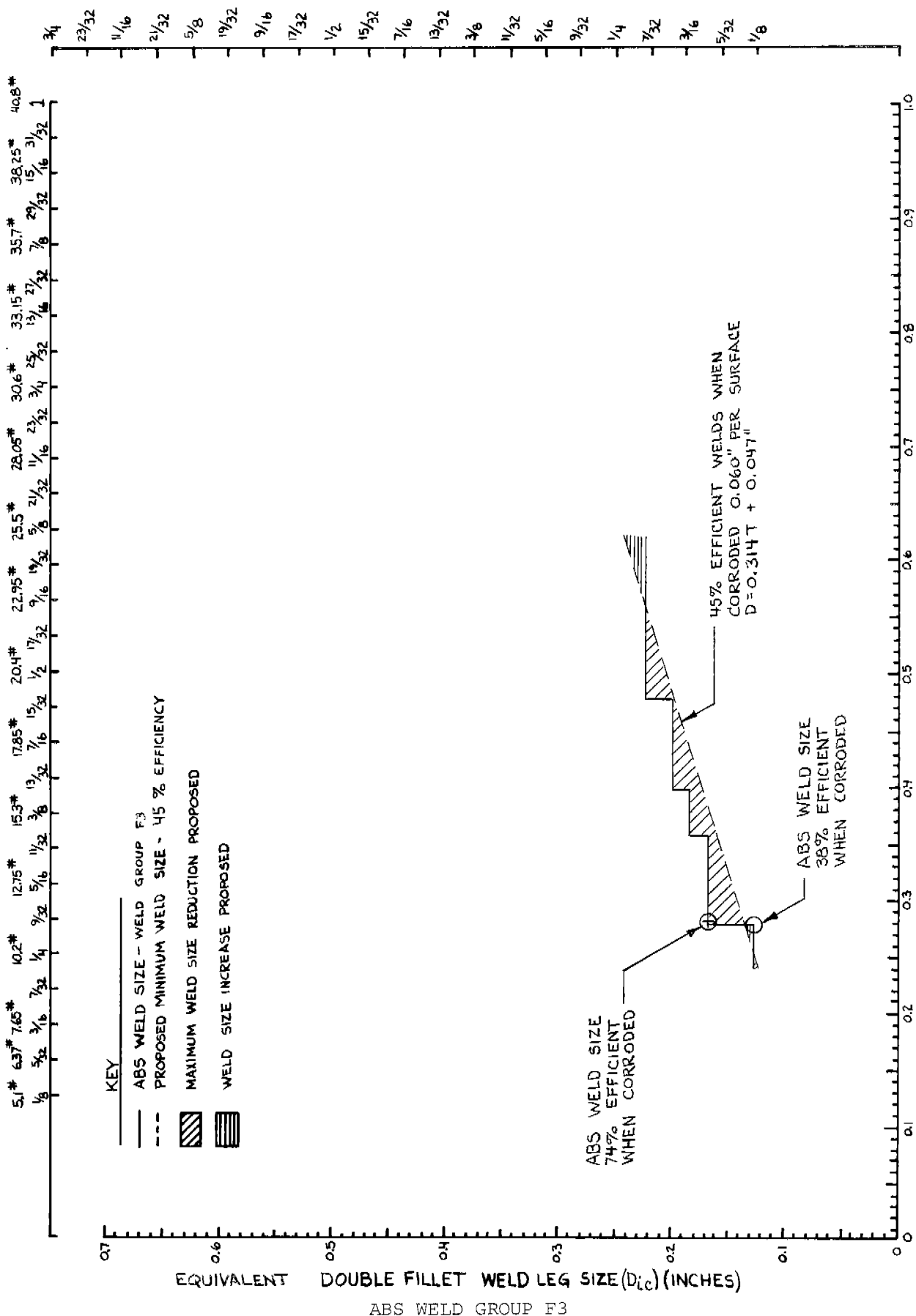

486-330

118

486-330

ABS WELD GROUPS G1 & J1
C-25

119

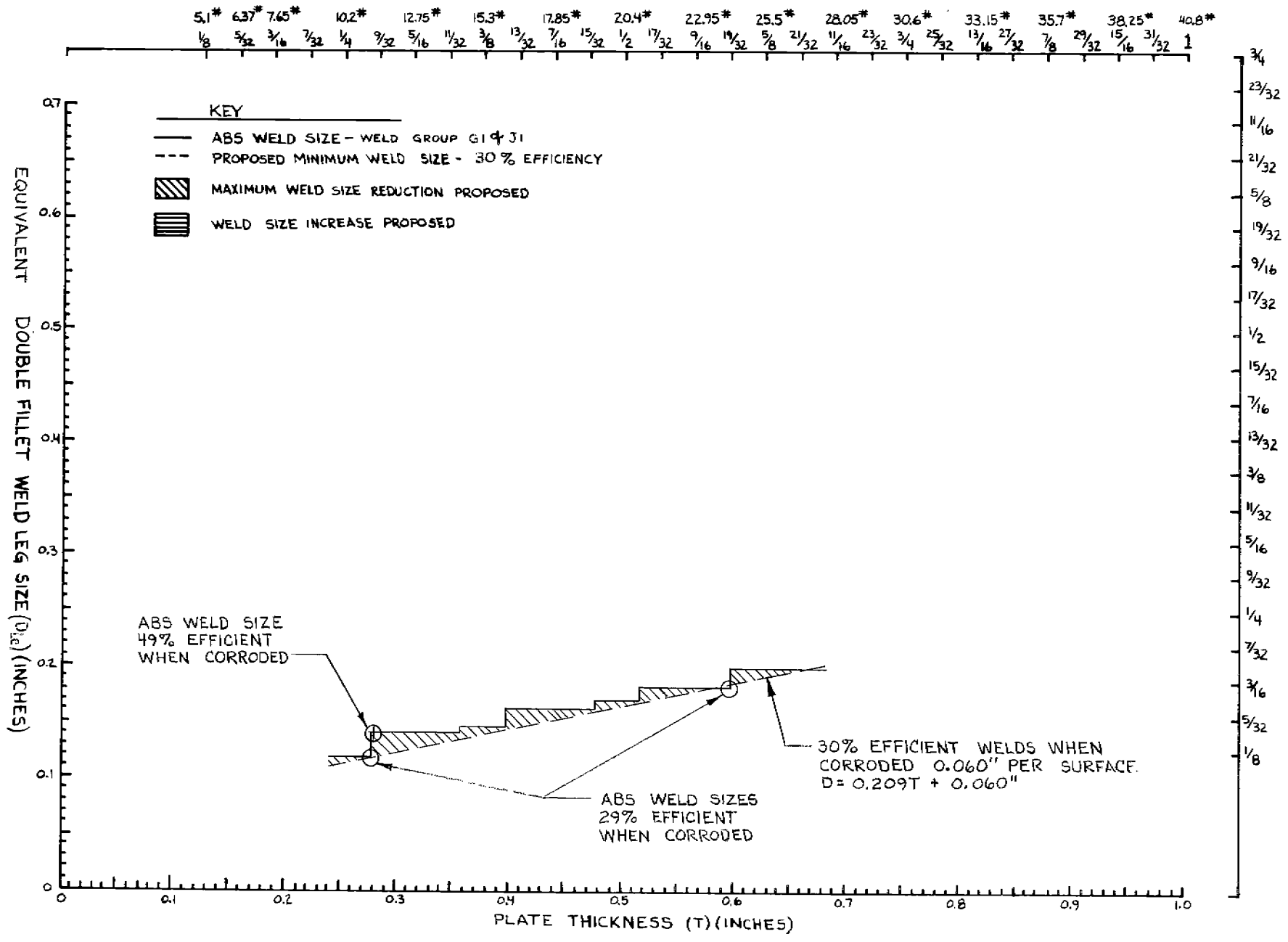

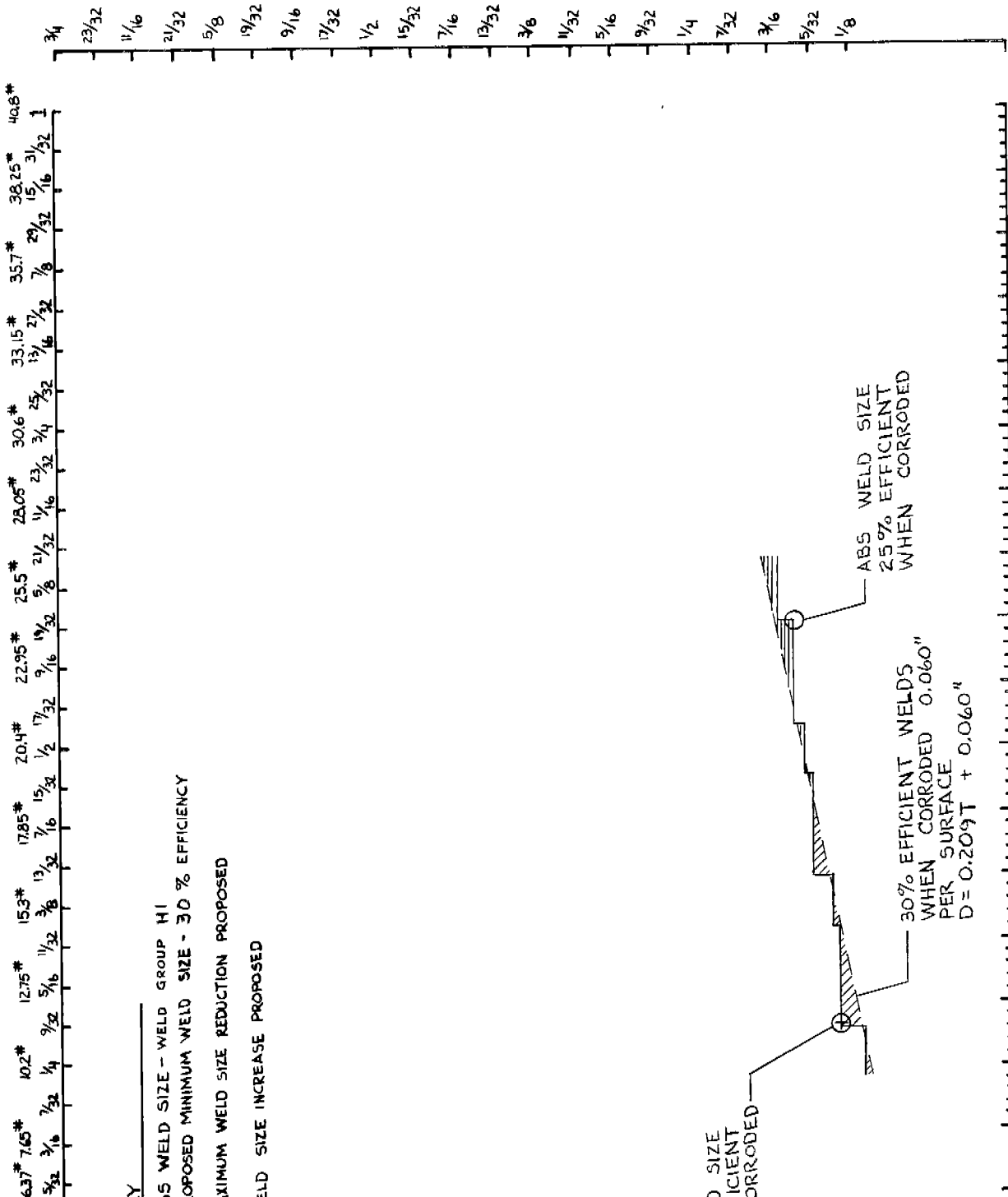

Y _____
 ABS WELD SIZE - WELD GROUP H1
 PROPOSED MINIMUM WELD SIZE - 30 % EFFICIENCY
 MAXIMUM WELD SIZE REDUCTION PROPOSED
 WELD SIZE INCREASE PROPOSED

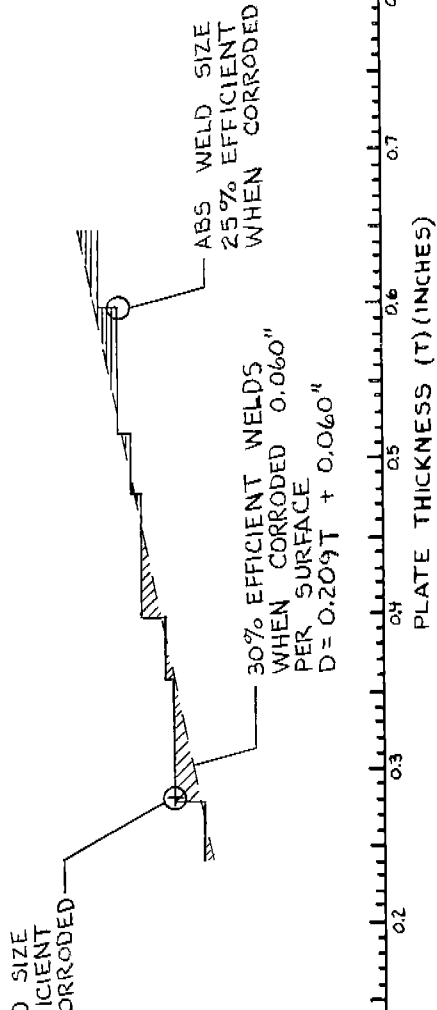

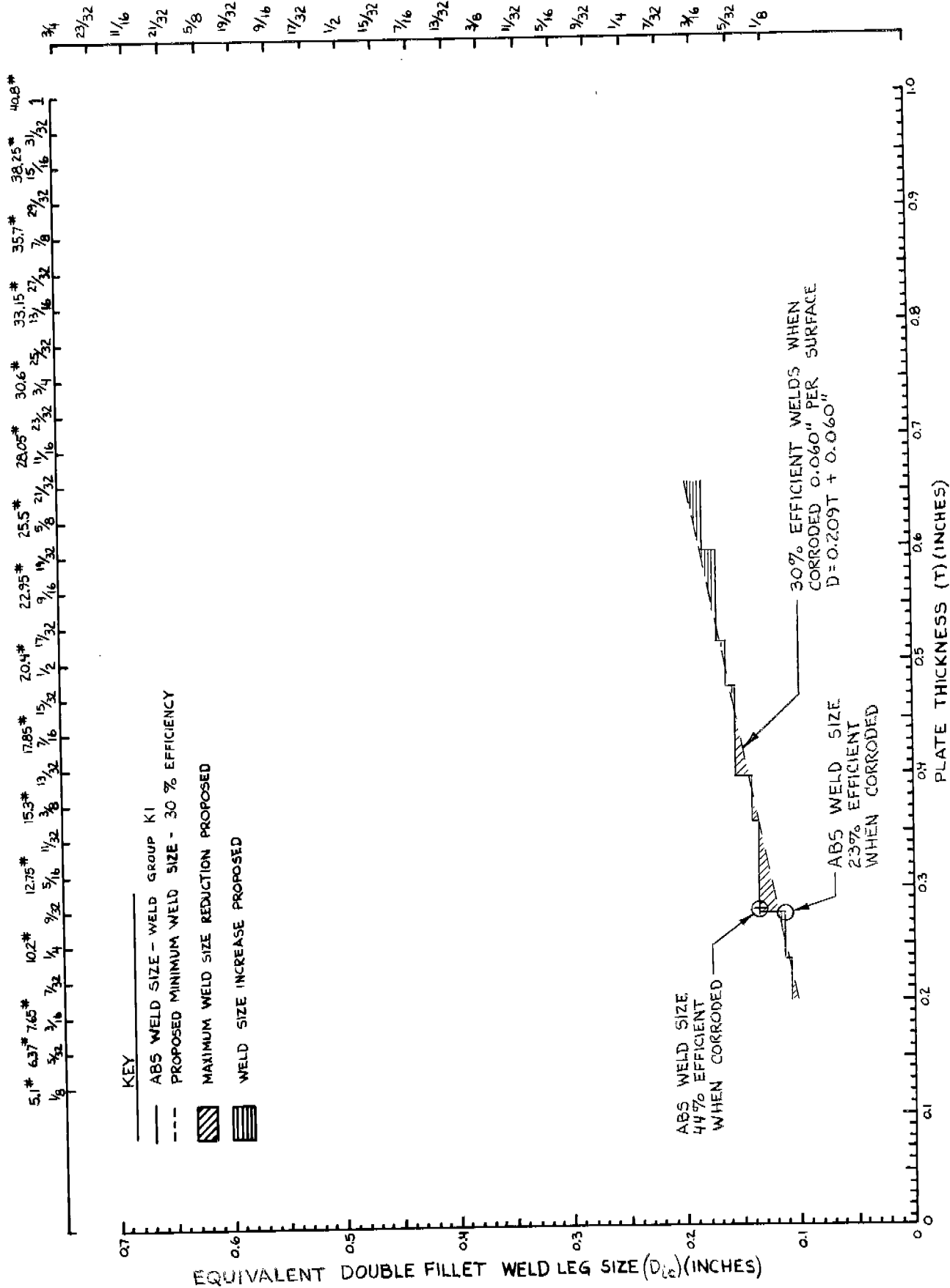

486-330

121

486-330

C-28

ABS WELD GROUPS K2 & M3

122

5.1* 6.37* 7.45* 10.2* 12.75* 15.3* 17.85* 20.4* 22.95* 25.5* 28.05* 30.6* 33.15* 35.7* 38.25* 40.8**

1/8 5/32 3/16 7/32 1/4 9/32 5/16 11/32 3/8 13/32 7/16 15/32 1/2 17/32 9/16 19/32 5/8 21/32 11/16 23/32 3/4 25/32 13/16 27/32 7/8 29/32 15/16 31/32 1

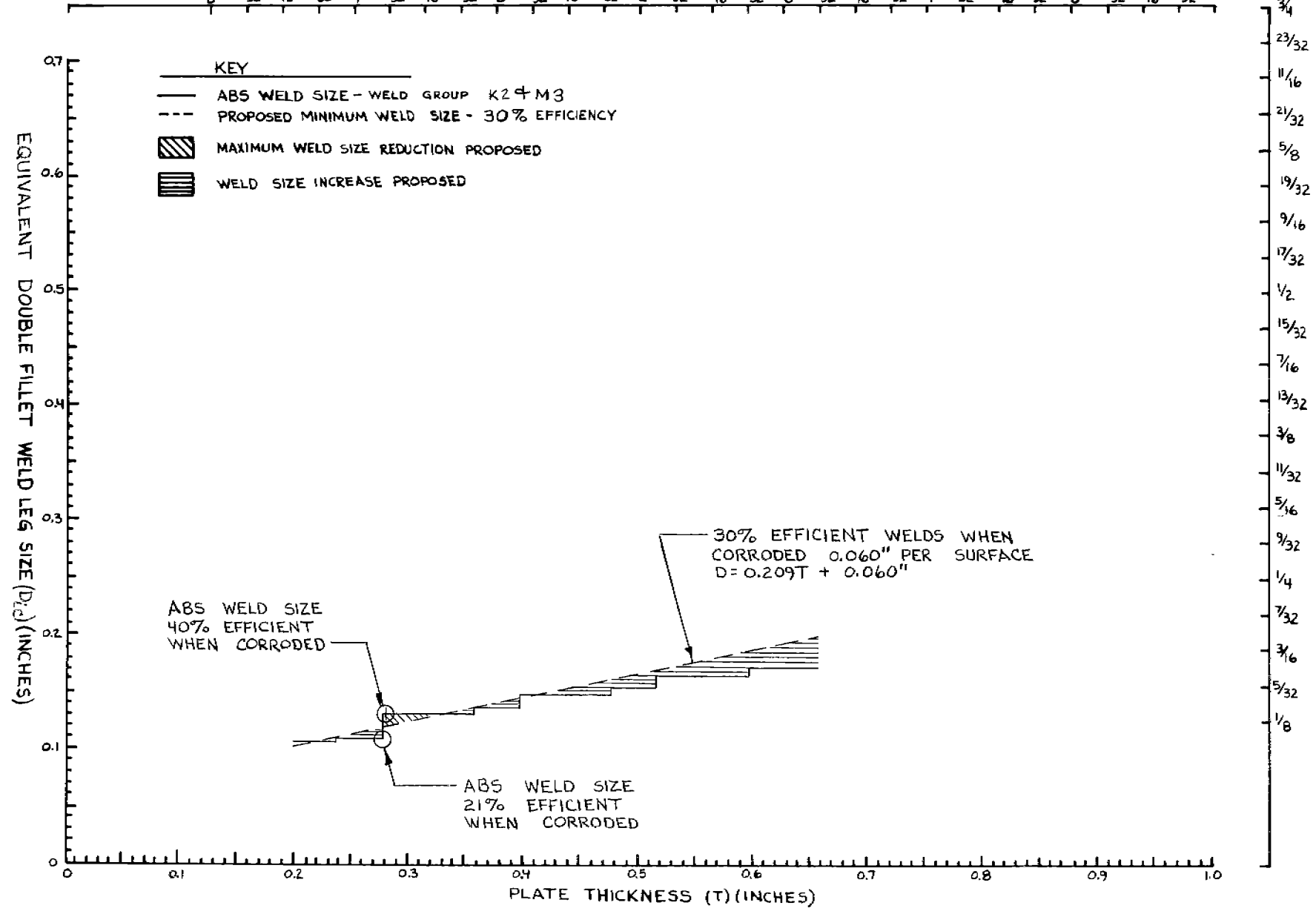

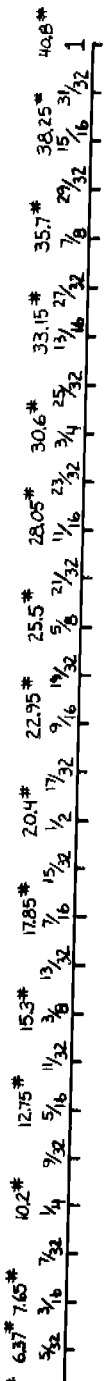

EY

B5 WELD SIZE - WELD GROUP K3 ϕ L1
 PROPOSED MINIMUM WELD SIZE - 30 % EFFICIENCY

MAXIMUM WELD SIZE REDUCTION PROPOSED

WELD SIZE INCREASE PROPOSED

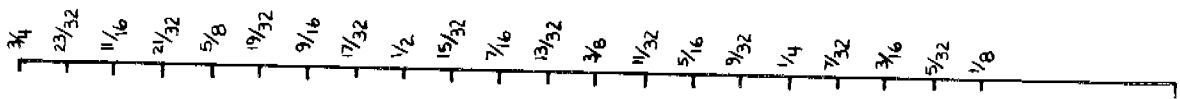

30% EFFICIENT WELDS WHEN
 CORRODED 0.060" PER SURFACE
 $D = 0.209T + 0.060"$

WELD SIZE
 EFFICIENT
 CORRODED

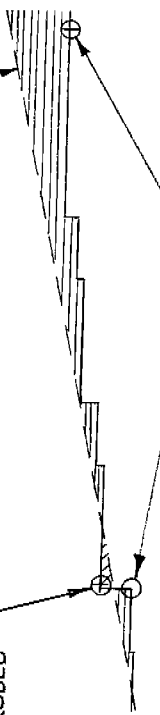

ABS WELD SIZES
 19% EFFICIENT
 WHEN CORRODED

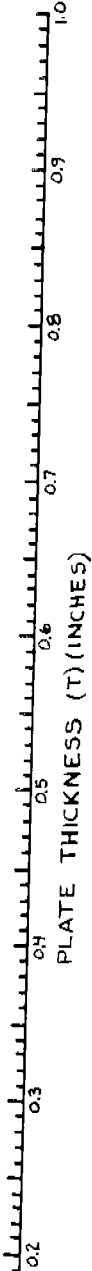

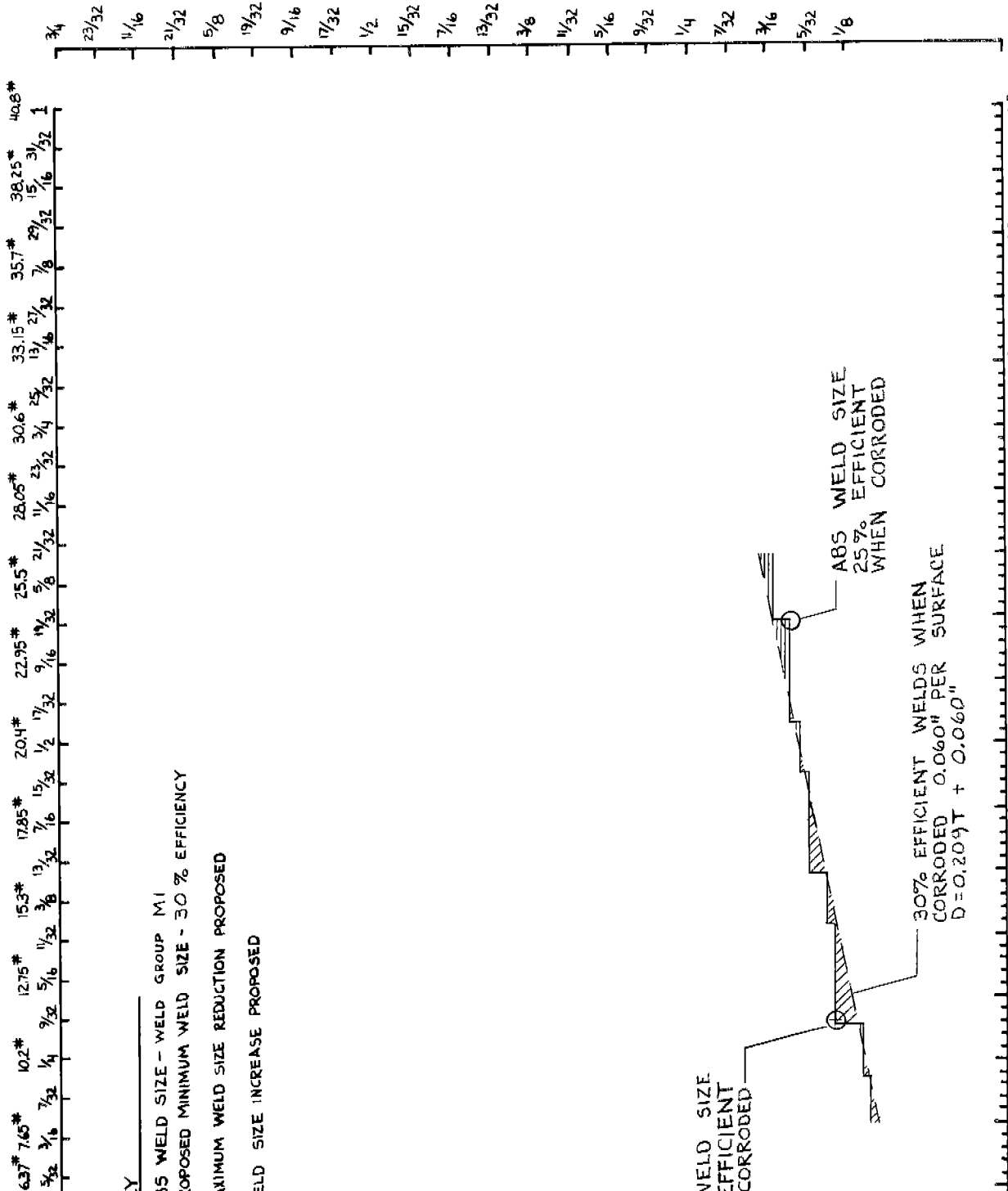

Y

30% WELD SIZE - WELD GROUP M1
 PROPOSED MINIMUM WELD SIZE - 30% EFFICIENCY

MINIMUM WELD SIZE REDUCTION PROPOSED

WELD SIZE INCREASE PROPOSED

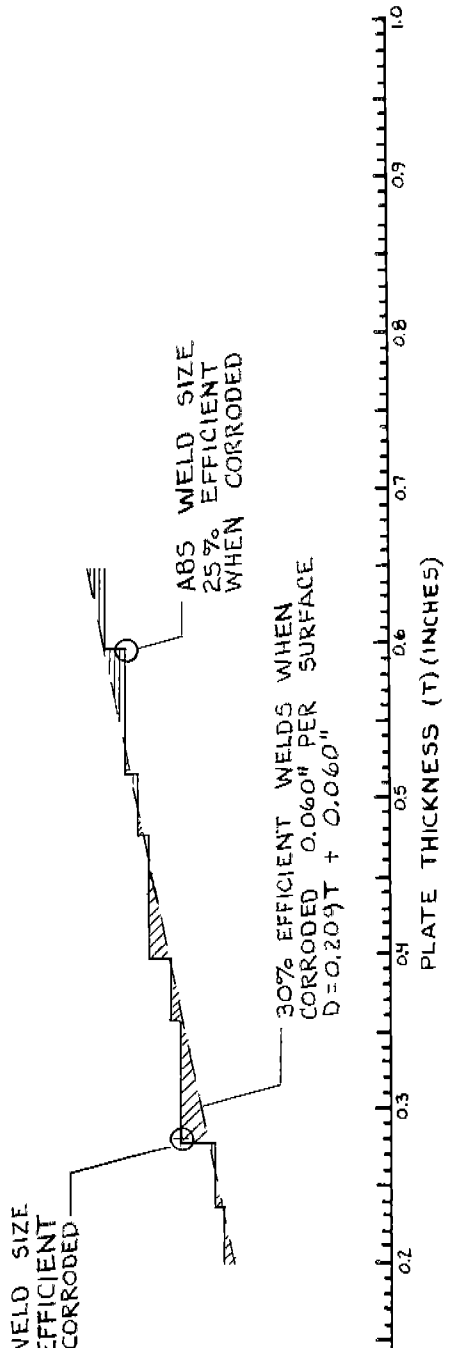

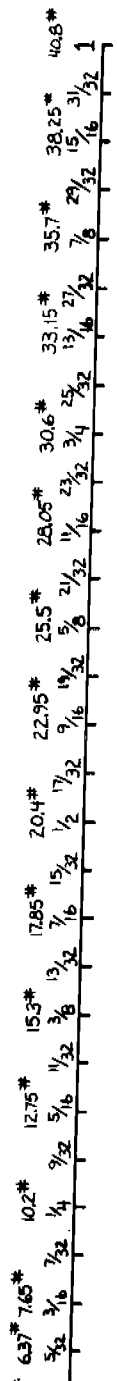

KEY

BS WELD SIZE - WELD GROUP M2

PROPOSED MINIMUM WELD SIZE - 30% EFFICIENCY

MAXIMUM WELD SIZE REDUCTION PROPOSED

WELD SIZE INCREASE PROPOSED

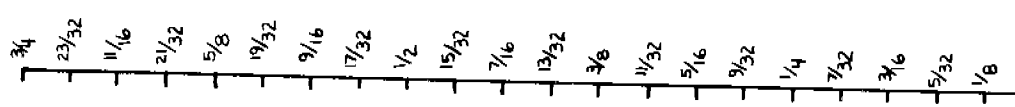

WELD SIZES
EFFICIENT
CORRODED



ABS WELD SIZES
23% EFFICIENT
WHEN CORRODED

30% EFFICIENT WELDS WHEN
CORRODED 0.060" PER SURFACE
D = 0.209T + 0.060"

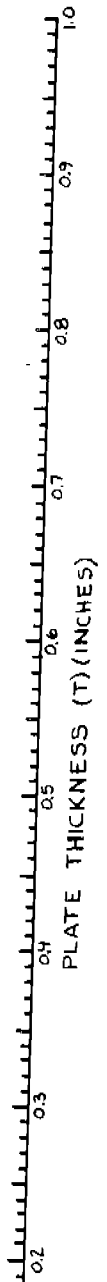

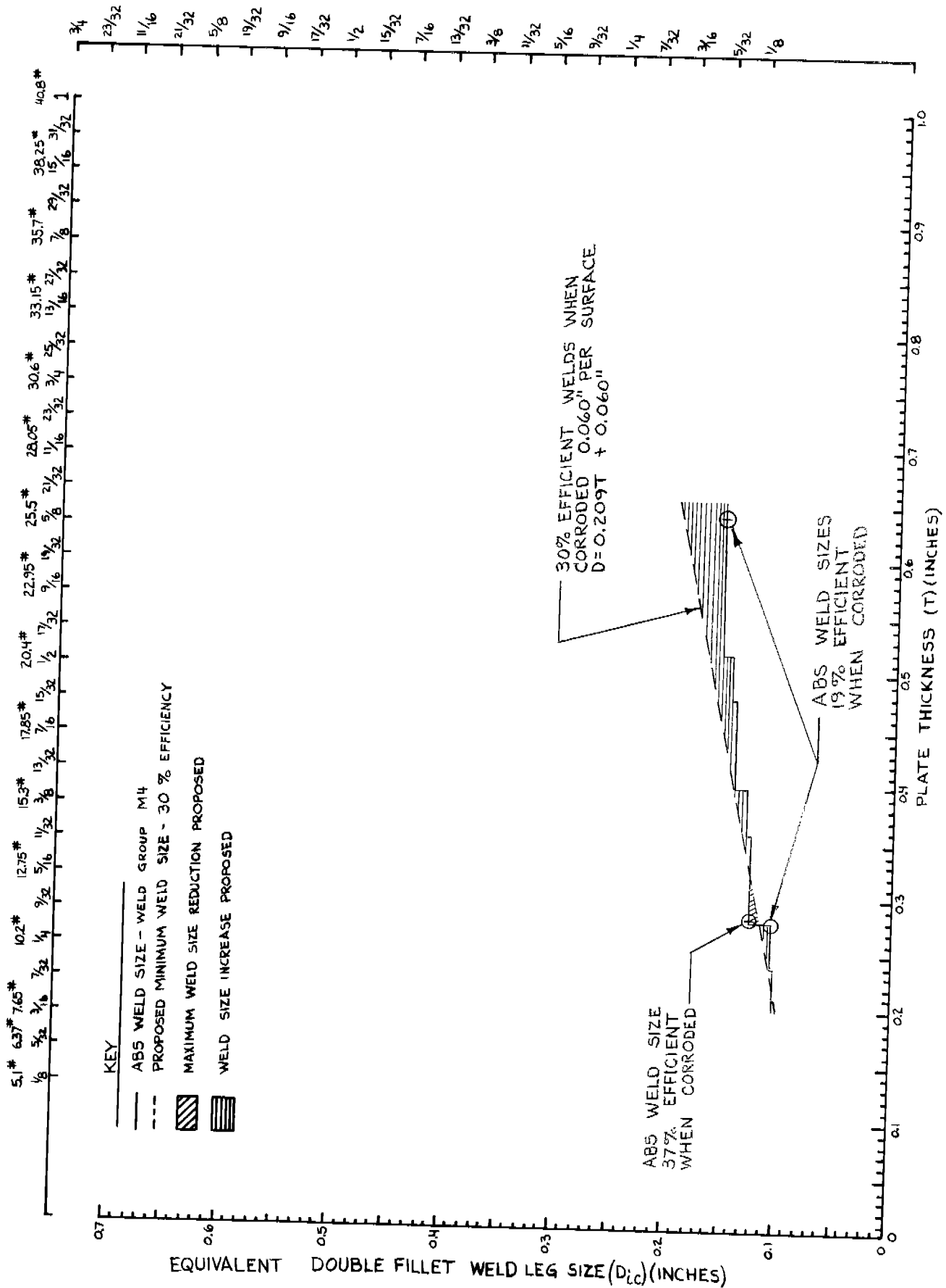

ABS WELD GROUP M4

486-330

126

486-330

ABS WELD GROUP M5
C-33

127

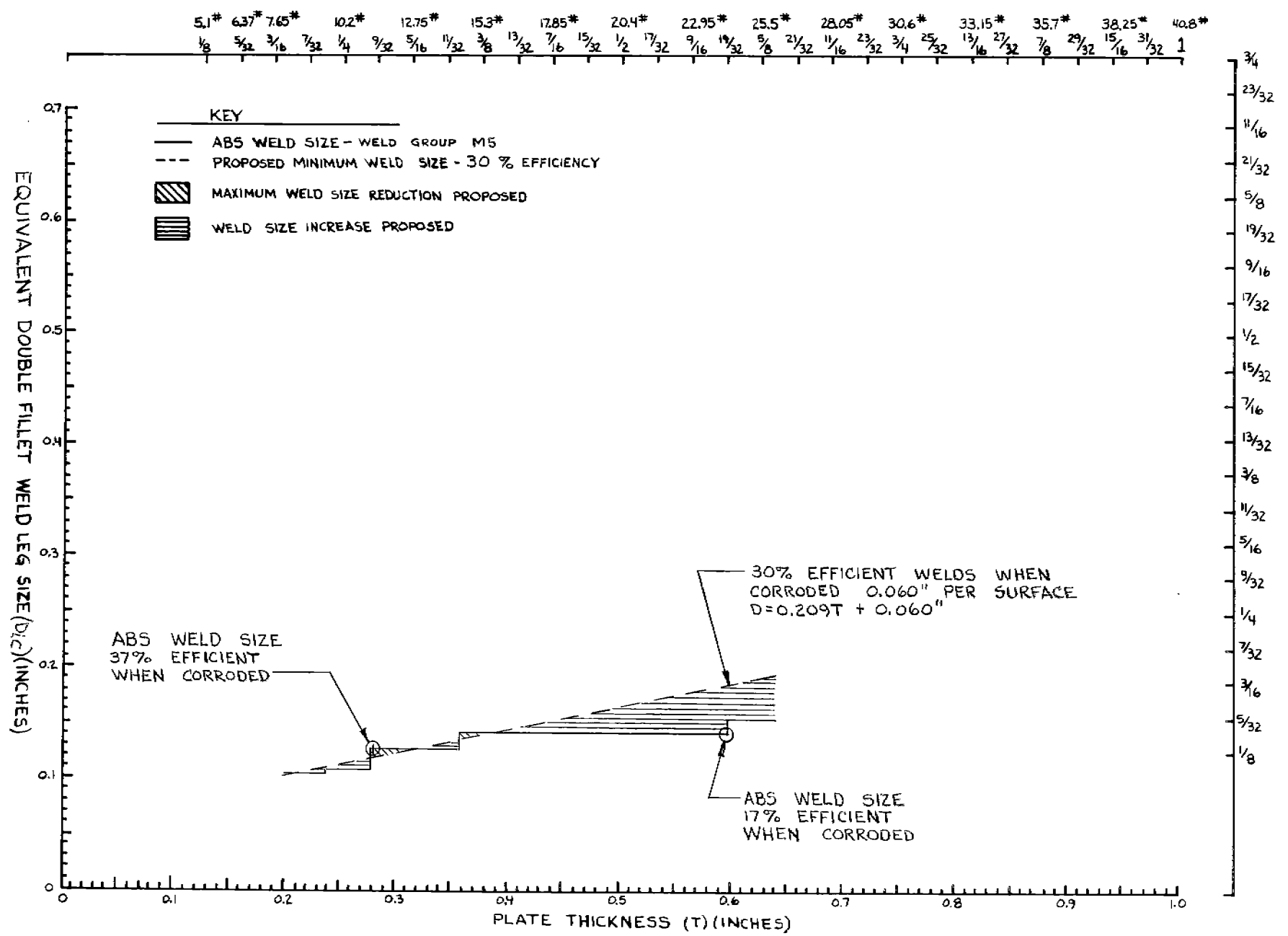

APPENDIX D

PROPOSED FILLET WELD SIZE TABLES

TABLE D-1

DOUBLE CONTINUOUS AND INTERMITTENT FILLET WELD EFFICIENCIES

For tee type joints, the weld size (D) is to be determined from the thickness (T) of the intercostal member (i.e., the member being attached). For lap joints and corner type joints, the weld size is to be determined from the thickness of the weaker member (i.e., member with lowest product of thickness times tensile strength).

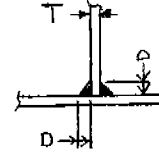

The weld size is not to be less than 1/8". For vessels to be classed "Oil Carrier", the weld size in cargo tanks and in ballast tanks in the cargo area is not to be less than 3/16".

Intermittent welds may be either staggered or chained unless otherwise specified.

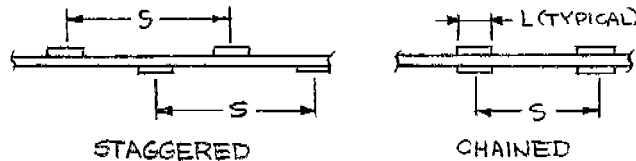

Where beams, stiffeners, frames, etc., are intermittently welded and pass through slotted girders, shelves or stringers, there is to be a pair of matched intermittent welds on each side of each such intersection and the beams, stiffeners and frames are to be efficiently attached to the girders, shelves and stringers.

486-330 (130)

TABLE D-1 (Cont'd)

<u>Line Nos.</u>	<u>Structural Items</u>	<u>Weld Efficiency Required</u>	<u>Intermittent Welding Permitted</u>
	Single-Bottom Floors		
1,6	To center vertical keel, side shell, longitudinal bulkhead, or other supporting member	75%	No
2	To shell-aft peaks of high power, fine form vessels	45%	
3,4,5	To shell-elsewhere, and to face plate	30%	
<hr/>			
	Double-Bottom Floors - Plate Floors		
13	To vertical margin plate or side girder under longitudinal or wing tank bulkhead	100%	No
12	To sloping margin plate, side shell, and bilge	75%	No
17	At oiltight and watertight periphery connections	75%	No
11	To center vertical keel and side girders where longitudinal girder is continuous	75%	No
10	To center vertical keel and side girders where floor is continuous	30%	
14	To inner bottom in machinery space	75%	No
15,16	To inner bottom-elsewhere (See Note 3)	30%	
7	To shell-aft peaks of high power, fine form vessels	45%	
8,9	To shell elsewhere (See Note 3)	30%	
18	Stiffeners	30%	

TABLE D-1 (Cont'd)

<u>Line Nos.</u>	<u>Structural Items</u>	<u>Weld Efficiency Required</u>	<u>Intermittent Welding Permitted</u>
	Double-Bottom Floors - Open Floor Brackets		
20	To margin plate	75%	No
19	To center vertical keel	30%	
<hr/>			
	Double Bottom - Center Girder		
24	At oiltight and watertight periphery connections	75%	No
21	To inner bottom in way of engine	75%	No
22	To inner bottom-clear of engine-nontight	45%	
23	To shell or bar keel	75%	No
25	Stiffeners	30%	
<hr/>			
	Double Bottom - Side Girders		
32	At oiltight and watertight periphery connections	75%	No
30	To floors in way of transverse bulkheads	75%	No
31	To floors-elsewhere	30%	
28	To inner bottom in way of engines	45%	
29	To inner bottom-elsewhere	30%	
26	To shell-flat of bottom forward (fore end strengthening)	45%	
27	To shell-elsewhere	30%	
33	Stiffeners	30%	

486-330

132

TABLE D-1 (Cont'd)

<u>Line Nos.</u>	<u>Structural Items</u>	<u>Weld Efficiency Required</u>	<u>Intermittent Welding Permitted</u>
34	Inner Bottom - Plating To shell and to other boundaries	75%	No
39	Frames - Transverse Unbracketed to inner bottom	75%	No
40	Frame brackets to frames, decks and inner bottom	60%	No
35	To shell-aft peaks of high power, fine form vessels	45%	
36,37,38	To shell-elsewhere	30%	See Note 4
42	Frames - Transverse Reverse To brackets	60%	No
41	To inner bottom	30%	
48	Frames - Longitudinal Brackets to longitudinals, floors, shell, etc.	60%	No
45	To shell on flat bottom forward	45%	No
43,44,46	To shell elsewhere	30%	
47	To inner bottom	30%	
51	Girders, Web Frames, Stringers and Deck Transverses End connections, unbracketed	100%	No
52	End connections, bracketed	75%	No
49,50	To shell and to bulkheads and decks	30%	
53A,53B	To face plate	30%	

TABLE D-1 (Cont'd)

<u>Line Nos.</u>	<u>Structural Items</u>	<u>Weld Efficiency Required</u>	<u>Intermittent Welding Permitted</u>
	Bulkheads - Plating		
57	Exposed bulkheads on freeboard and superstructure decks-periphery	75%	No
56A	Tank bulkheads-periphery	75%	No
56B	Watertight bulkheads-periphery	75%	See Table D-4
54,55	Swash bulkhead or non-tight structural bulkhead-periphery	30%	
<hr/>			
	Bulkheads - Stiffeners		
62	End attachments, unbracketed	75%	No
63	Brackets to stiffeners, bulkhead, deck, inner bottom, etc.	60%	No
58,59	To deep tank bulkheads, watertight bulkheads and superstructure or deckhouse front bulkheads	30%	See Note 4
60,61	To non-tight structural bulkhead, deckhouse side, and superstructure aft end bulkheads	30%	See Note 5
<hr/>			
	Decks - Plating		
64,65	Strength deck, exposed decks, watertight and oiltight decks - periphery	75%	No
66	Platform decks, non-tight flats-periphery	45%	No
<hr/>			
	Decks - beams and Longitudinals		
69	End attachments, beams, unbracketed	75%	No
70	Beam knees and brackets to beams, longitudinals, decks, bulkheads, etc.	60%	No

TABLE D-1 (Cont'd)

<u>Line Nos.</u>	<u>Structural Items</u>	<u>Weld Efficiency Required</u>	<u>Intermittent Welding Permitted</u>
Decks - Beams and Longitudinals (Cont'd)			
68	To decks, slab longitudinals	30%	No
67	To decks, except slab longitudinals	30%	
Decks - Hatch Coamings and Ventilators			
71	To deck	75%	No
Hatch Covers - Plating			
72A	Watertight or oiltight-periphery	75%	No
72B	Weathertight-periphery	75%	See Table D-4
Hatch Covers - Stiffeners and Webs			
74	End attachment-unbracketed to side plate or other stiffeners	75%	No
75	Bracket to stiffener or side plate	60%	No
73	To plating and to face plate	30%	See Note 7
Foundations - Main Engine, Boilers, and Auxiliaries			
76,77	To top plate, shell, or inner bottom	75%	No
Rudders - Horizontal Diaphragms			
79	To vertical diaphragm in way of rudder axis	75%	No
78	To side plating	45%	
	- Vertical Diaphragms		
	In way of rudder axis to top and bottom castings	Full Penetration Welds Required	
80,81	To side plating and horizontal diaphragms	45%	

TABLE D-1 (Cont'd)

<u>Line Nos.</u>	<u>Structural Items</u>	<u>Weld Efficiency Required</u>	<u>Intermittent Welding Permitted</u>
82	Rudders - Side Plating Slot welds (See Note 2)	75%	No
<hr/> ADDITIONAL WELDING REQUIREMENTS FOR VESSELS CLASSED "OIL CARRIERS" (See Note 6 for intermittent welding)			
83	Girders and Webs Centerline girder to shell	88%	No
84	Centerline girder to shell, mid 0.5 span (See Note 1)	60%	No
85	Centerline girder to deck	75%	No
86	Centerline girder to deck, mid 0.5 span (See Note 1)	60%	No
87	Transverse bulkhead, webs to bulkhead	75%	No
88	Transverse bulkhead, webs to bulkhead, mid 0.5 span (See Note 1)	60%	No
89	To face bars	45%	
90	End Attachments Bracketed	88%	No
91	Transverses Bottom transverse to shell	88%	No
92	Bottom transverse to shell mid 0.5 span (See Note 1)	60%	No
93	Side transverse and longitudinal bulkhead web to plating	75%	No

TABLE D-1 (Cont'd)

<u>Line Nos.</u>	<u>Structural Items</u>	<u>Weld Efficiency Required</u>	<u>Intermittent Welding Permitted</u>
	Transverses (Cont'd)		
94	Deck transverse to deck	75%	No
95	Deck transverse to deck, mid 0.5 span (See Note 1)	60%	No
96	To face bars	45%	

See General Notes at Beginning of Table.

NOTES

1. This may be applied only where the shearing forces over the mid-half span are no greater than one half the maximum shearing force on the member and where the web is of the same depth clear of end brackets and of the same thickness throughout the length of the member.
2. The weld size is to be determined from the thickness of the side plating.
3. With longitudinal framing the weld size is to be increased to give an equivalent weld area to that obtained without cut-outs for longitudinals.
4. Unbracketed stiffeners of shell, watertight and oiltight bulkheads and house fronts are to have double continuous welds for one-tenth of their length at each end.
5. Unbracketed stiffeners of nontight structural bulkheads, deckhouse sides and after ends are to have a pair of matched intermittent welds at each end.
6. The welding of deck and shell longitudinals may be as required under decks or frames. In addition the shell longitudinals are to have double continuous welds at the ends and in way of transverses equal in length to the depth of the longitudinal. The deck longitudinals are also to have double continuous welds at the ends equal in length to the depth of the longitudinal, however at transverses a matched pair of welds will be acceptable.
7. Unbracketed stiffeners and webs of hatch covers are to be welded continuously to the plating and to the face plate for a length at ends equal to the end depth of the member.

TABLE D-2

Proposed Double Continuous Fillet Weld Sizes Versus Plate Thickness

Eff.	Size Equation	Plate Thickness (T)														
		1/8 5.1#	3/16 7.65#	1/4 10.2#	5/16 12.75#	3/8 15.3#	7/16 17.85#	1/2 20.4#	9/16 22.95#	5/8 25.5#	11/16 28.05#	3/4 30.6#	13/16 33.15#	7/8 35.1#	15/16 38.25#	1 40.8#
100%	D=0.698 T + 0.001"	1/8	3/16 1/8	3/16	1/4	5/16 1/4	5/16	3/8	7/16 3/8	7/16	1/2	9/16 1/2	5/8 9/16	5/8	-	-
88%	D=0.614 T + 0.011"	1/8	3/16 1/8	3/16	1/4 3/16	1/4	5/16 1/4	3/8 5/16	3/8	7/16 3/8	7/16	1/2	9/16 1/2	9/16	5/8 9/16	5/8
75%	D=0.524 T + 0.022"	1/8	1/8	3/16 1/8	3/16	1/4 3/16	5/16 1/4	5/16	3/8 5/16	3/8	7/16 3/8	7/16	1/2 7/16	1/2	9/16 1/2	9/16
60%	D=0.419 T + 0.035"	1/8	1/8	3/16 1/8	3/16	1/4 3/16	1/4 3/16	1/4	5/16 1/4	5/16	3/8 5/16	3/8	7/16 3/8	7/16 3/8	7/16	1/2 7/16
45%	D=0.314 T + 0.047"	1/8	1/8	3/16 1/8	3/16 1/8	3/16	3/16	1/4 3/16	1/4	1/4	5/16 1/4	5/16	5/16	3/8 5/16	3/8 5/16	3/8
30%	D=0.209 T + 0.060"	1/8	1/8	1/8	3/16 1/8	3/16 1/8	3/16 1/8	3/16	3/16	1/4 3/16	1/4 3/16	1/4 3/16	1/4	1/4	5/16 1/4	5/16 1/4

NOTES: (1) For intermediate plate thicknesses, see Figures D-1 and D-2 or use equation in second column.
 (2) This table includes a corrosion allowance of 0.060" per surface.

TABLE D-3

Proposed Intermittent Fillet Weld Sizes Versus Plate Thickness

Eff.	Size Equation	Plate Thickness (T)									
		1/8 5.1#	3/16 7.65#	1/4 10.2#	5/16 12.75#	3/8 15.3#	7/16 17.85#	1/2 20.4#	9/16 22.95#	5/8 25.5#	11/16 28.05#
45%	D=0.314 x (T-0.12") x S/L + 0.085"	-	-	1/4 3-12 ⁽²⁾	1/4 3-8	1/4 3-6	5/16 3-6	5/16 3-5	3/8 3-6	3/8 3-5	-
30%	D=0.209 (T-0.12") S/L + 0.085"	3/16 2-1/2 -12 ⁽²⁾	3/16 2-1/2 -12 ⁽²⁾	3/16 2-1/2 -8	1/4 3-12	1/4 3-9	1/4 3-7	1/4 3-6	1/4 3-5	5/16 3-6	-

NOTES:

- (1) For intermediate plate thicknesses, see Figures D-3 and D-4 or use equations in second column.
- (2) Fillet welds are to be staggered.
- (3) Weld sizes other than given in the table may be used provided the length and/or spacing of welds is modified to give equivalent strength. Use equations shown in second column or see Table D-5.
- (4) This table includes a corrosion allowance of 0.060" per surface.

486-330 - (138)

TABLE D-4

Proposed Weld Sizes For Special Cases

Line No.	Location	Size Equation	Notes	Plate Thickness(T)						
				1/4	5/16	3/8	7/16	1/2	9/16	5/8
				10.2#	12.75#	15.3#	17.85#	20.4#	22.95#	25.5#
56B	One Side	$D=T-1/16''$	(1)	3/16	1/4	5/16	3/8	7/16	-	-
	Other Side (30% eff.)	$D=0.209(T-0.12'')$ $S/L + 0.085''$	(2)	3/16 2-1/2 -8	1/4 3-12	1/4 3-9	1/4 3-7	1/4 3-6	-	-
72B	Outside (75% eff.)	$D=0.524 T+0.022''$	(3)	3/16	3/16	1/4	5/16	5/16	3/8	3/8
	Inside (30% eff.)	$D=0.209(T-0.12'')$ $S/L + 0.085''$	(2)	3/16 2-1/2 -8	1/4 3-12	1/4 3-9	1/4 3-7	1/4 3-6	1/4 3-5	5/16 3-6

NOTES:

- (1) For intermediate plate thicknesses, use size for next larger thickness listed or use equation in third column.
- (2) For intermediate plate thicknesses, see Figure D-4 or use equation in third column.
- (3) For intermediate plate thicknesses, see Figure D-1 or use equation in third column.
- (4) This table includes a corrosion allowance of 0.060" per surface.

D-11

486-330-139

TABLE D-5

Equivalent Continuous Fillet Weld Sizes for Intermittent Welds Including Corrosion Allowance and Maximum Plate Thickness Allowed for 45% and 30% Efficient Welds

Intermittent Weld Size D x L - S	Equiv. Cont. Fillet Weld $D_{ic} = (D - 0.085")$ $L/S + 0.085"$ (Inches)	T_{max} for 45% Eff. $= \frac{D_{ic}}{0.047"} - 0.047"$ (Inches)	T_{max} for 30% Eff. $= \frac{D_{ic}}{0.060"} - 0.060"$ (Inches)	Intermittent Weld Size D x L - S	Equiv. Cont. Fillet Weld $D_{ic} = (D - 0.085")$ $L/S + 0.085"$ (Inches)	T_{max} for 45% Eff. $= \frac{D_{ic}}{0.047"} - 0.047"$ (Inches)	T_{max} for 30% Eff. $= \frac{D_{ic}}{0.060"} - 0.060"$ (Inches)
3/8 3-5	0.259	0.6752					
3/8 3-6	0.230	0.5828					
5/16 3-5	0.2215	0.5557	0.7727	3/16 2-1/2 - 5	0.13625	0.2842	0.3648
5/16 3-6	0.19875	0.4833	0.6639	3/16 2-1/2 - 6	0.12771	0.2570	0.3240
5/16 3-7	0.1825	0.4315	0.5861	3/16 2-1/2 - 7	0.12161	0.2376	0.2948
5/16 3-8	0.17031	0.3927	0.5278	3/16 2-1/2 - 8	0.11703	0.2230	0.2729
5/16 3-9	0.16083	0.3625	0.4824	3/16 2-1/2 - 9	0.11347	0.2117	0.2558
5/16 3-10	0.15325	0.3384	0.4462	3/16 2-1/2 - 10	0.11062	0.2026	0.2422
3/16 3-11	0.14705	0.3186	0.4165	3/16 2-1/2 - 11	0.10830	0.1952	0.2311
5/16 3-12	0.14188	0.3022	0.3918	3/16 2-1/2 - 12	0.10636	0.1890	0.2218
1/4 3-5	0.1840	0.4363	0.5933	3/16 2-1/8 - 4	0.13945	0.2944	0.3801
1/4 3-6	0.1675	0.3838	0.5144				
1/4 3-7	0.1557	0.3462	0.4579	3/16 2-1/8 - 10	0.10678	0.1904	0.2238
1/4 3-8	0.14688	0.3181	0.4157	3/16 2-1/8 - 11	0.10480	0.1841	0.2144
1/4 3-9	0.1400	0.2962	0.3828	3/16 2-1/8 - 12	0.10315	0.1788	0.2065
1/4 3-10	0.1345	0.2787	0.3565				
1/4 3-11	0.1300	0.2643	0.3349				
1/4 3-12	0.12625	0.2524	0.3170				

NOTES: (1) This table includes a corrosion allowance of 0.060" per surface

D-12

486-330

(140)

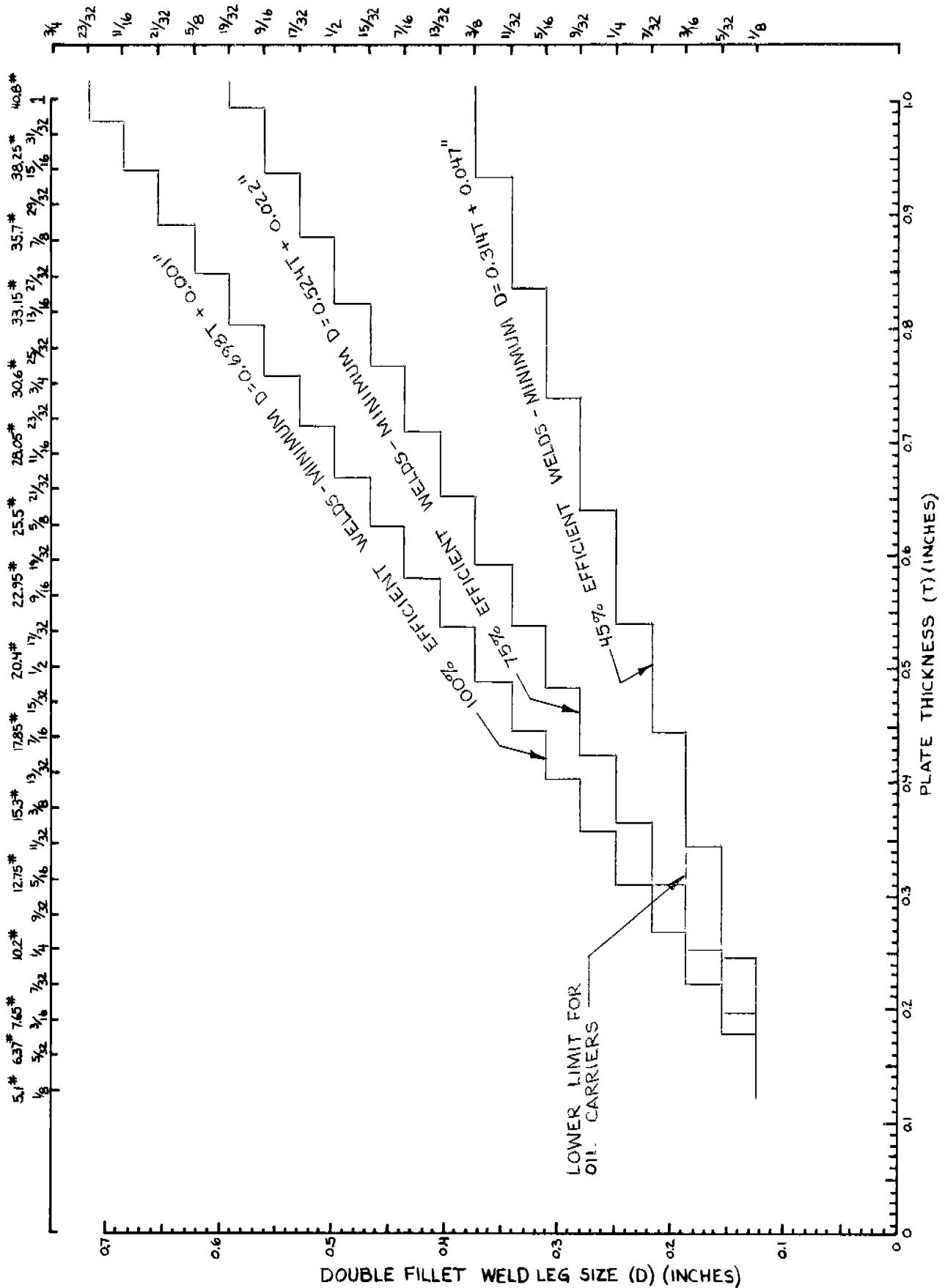

FIGURE D-1
 PROPOSED 100%, 75%, & 45% EFFICIENT DOUBLE CONTINUOUS
 FILLET WELDS INCLUDING CORROSION ALLOWANCE

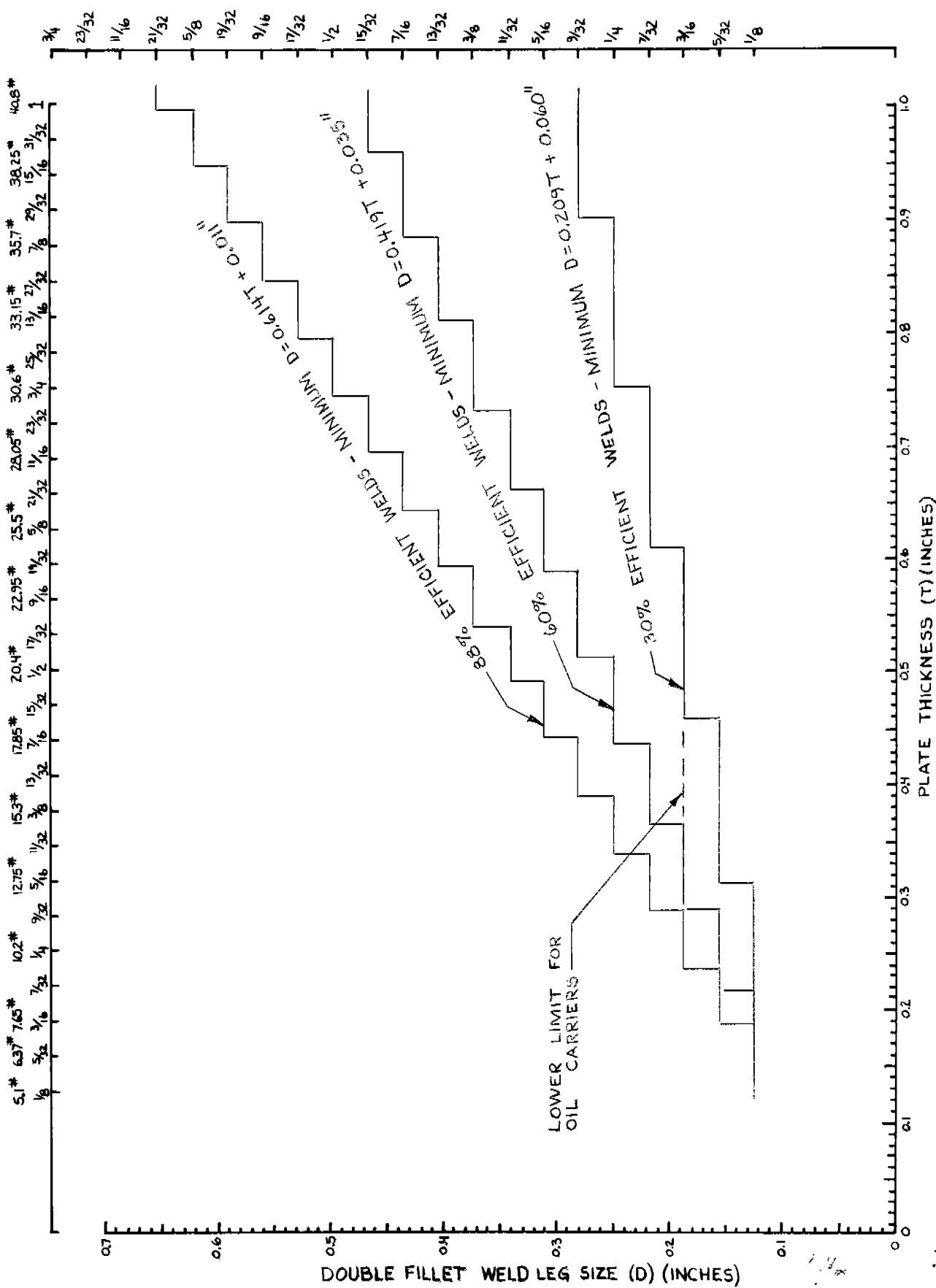

FIGURE D-2
 PROPOSED 88%, 60%, & 30% EFFICIENT DOUBLE CONTINUOUS
 FILLETS WELDS INCLUDING CORROSION ALLOWANCE

486-330-142

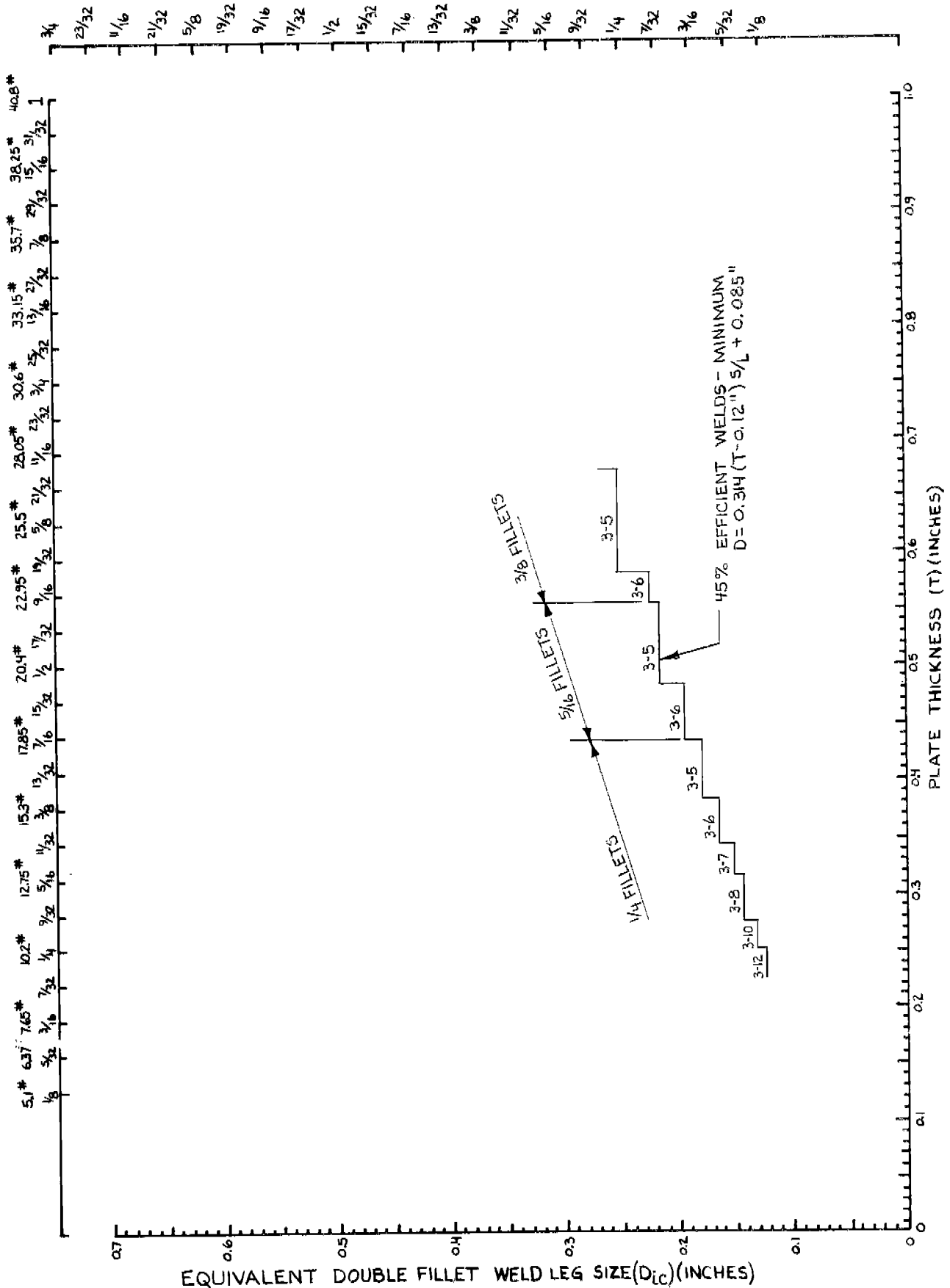

FIGURE D-3
PROPOSED 45% EFFICIENT INTERMITTANT FILLET WELDS
INCLUDING CORROSION ALLOWANCE

486-330 (143)

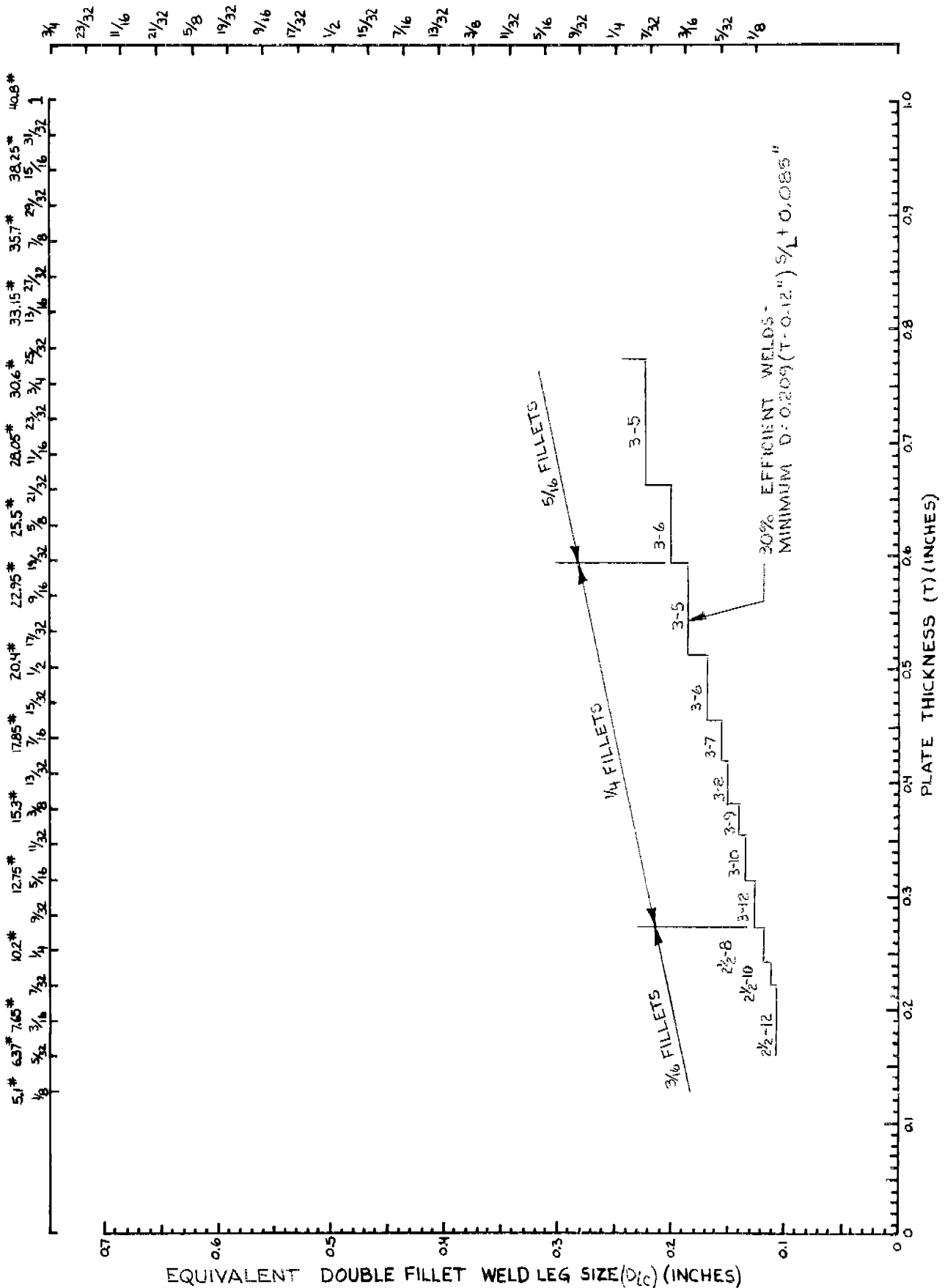

FIGURE D-4
PROPOSED 30% EFFICIENT INTERMITTENT FILLET WELDS
INCLUDING CORROSION ALLOWANCE

TABLE D-6

Proposed Double Continuous Fillet Weld Sizes Versus Plate Thickness - Mild Steel Only

Eff.	Size Equation	Plate Thickness (T)														
		1/8	3/16	1/4	5/16	3/8	7/16	1/2	9/16	5/8	11/16	3/4	13/16	7/8	15/16	1
		5.1#	7.65#	10.2#	12.75#	15.3#	17.85#	20.4#	22.95#	25.5#	28.05#	30.6#	33.15#	35.7#	38.25#	40.8#
100%	$D=0.628 T + 0.010''$	1/8	$\frac{3/16}{1/8}$	3/16	$\frac{1/4}{3/16}$	1/4	5/16	$\frac{3/8}{5/16}$	3/8	$\frac{7/16}{3/8}$	$\frac{1/2}{7/16}$	1/2	$\frac{9/16}{1/2}$	9/16	5/8	-
88%	$D=0.553 T + 0.019''$	1/8	1/8	$\frac{3/16}{1/8}$	$\frac{1/4}{3/16}$	1/4	$\frac{5/16}{1/4}$	5/16	$\frac{3/8}{5/16}$	3/8	$\frac{7/16}{3/8}$	7/16	$\frac{1/2}{7/16}$	$\frac{9/16}{1/2}$	9/16	$\frac{5/8}{9/16}$
75%	$D=0.471 T + 0.028''$	1/8	1/8	$\frac{3/16}{1/8}$	3/16	$\frac{1/4}{3/16}$	1/4	$\frac{5/16}{1/4}$	5/16	$\frac{3/8}{5/16}$	3/8	$\frac{7/16}{3/8}$	7/16	$\frac{1/2}{7/16}$	1/2	$\frac{9/16}{1/2}$
60%	$D=0.377 T + 0.040''$	1/8	1/8	$\frac{3/16}{1/8}$	$\frac{3/16}{1/8}$	3/16	$\frac{1/4}{3/16}$	1/4	$\frac{5/16}{1/4}$	$\frac{5/16}{1/4}$	5/16	$\frac{3/8}{5/16}$	3/8	3/8	$\frac{7/16}{3/8}$	7/16
45%	$D=0.283 T + 0.051''$	1/8	1/8	1/8	$\frac{3/16}{1/8}$	3/16	3/16	$\frac{1/4}{3/16}$	$\frac{1/4}{3/16}$	1/4	1/4	$\frac{5/16}{1/4}$	5/16	5/16	$\frac{3/8}{5/16}$	$\frac{3/8}{5/16}$
30%	$D=0.188 T + 0.062''$	1/8	1/8	1/8	1/8	$\frac{3/16}{1/8}$	$\frac{3/16}{1/8}$	$\frac{3/16}{1/8}$	3/16	3/16	$\frac{1/4}{3/16}$	$\frac{1/4}{3/16}$	$\frac{1/4}{3/16}$	1/4	1/4	1/4

NOTES: (1) For intermediate plate thicknesses, see Figures D-5 and D-6 or use equations in second column.
 (2) This Table includes a corrosion allowance of 0.060" per surface

D-17

486-330-145

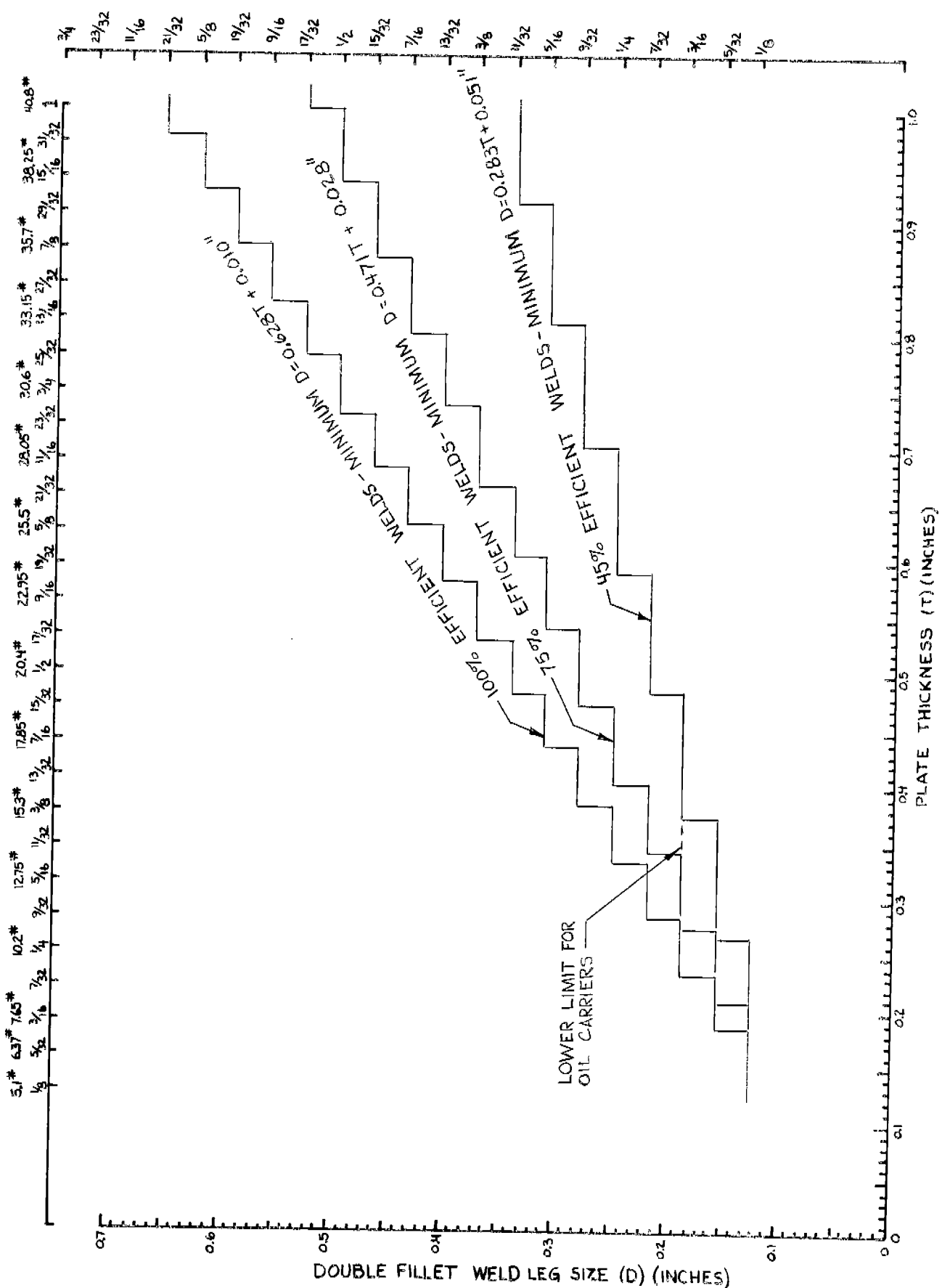

FIGURE D-5
 PROPOSED 100%, 75%, & 45% EFFICIENT DOUBLE CONTINUOUS
 FILLET WELDS INCLUDING CORROSION ALLOWANCE
 MILD STEEL ONLY
 D 16

486-330-146

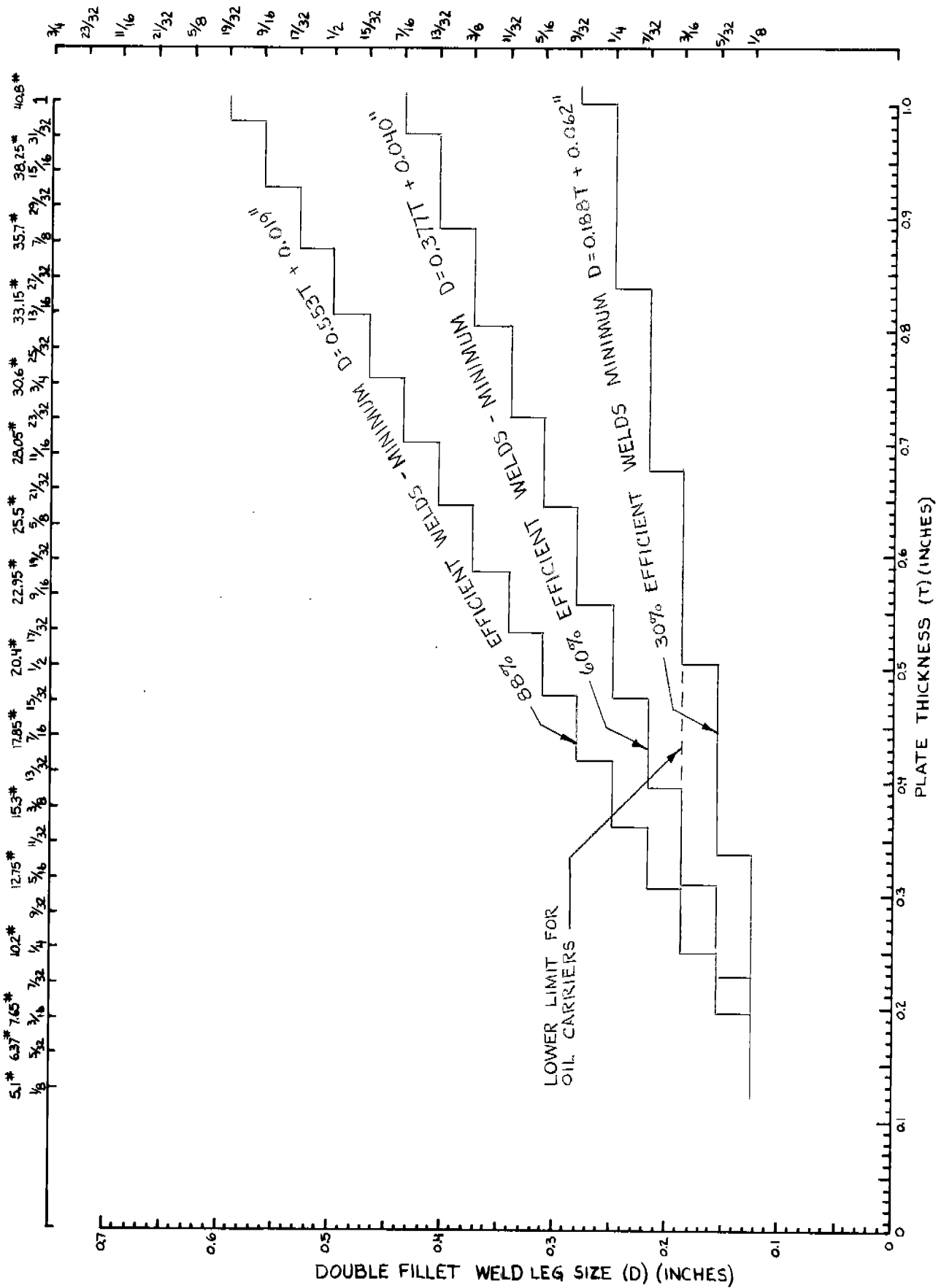

FIGURE D-6
 PROPOSED 88%, 60%, & 30% EFFICIENT DOUBLE CONTINUOUS
 FILLET WELDS INCLUDING CORROSION ALLOWANCE
 MILD STEEL ONLY

486-330 - (197) (148 BLK)

APPENDIX E

CALCULATIONS FOR VOYAGER CLASS TANKER

E-1

486-330 - (149)

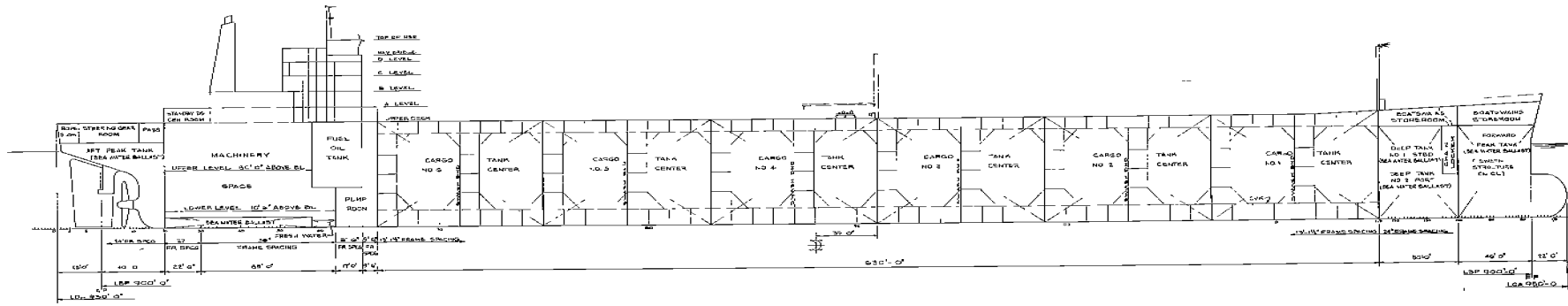

INBOARD PROFILE

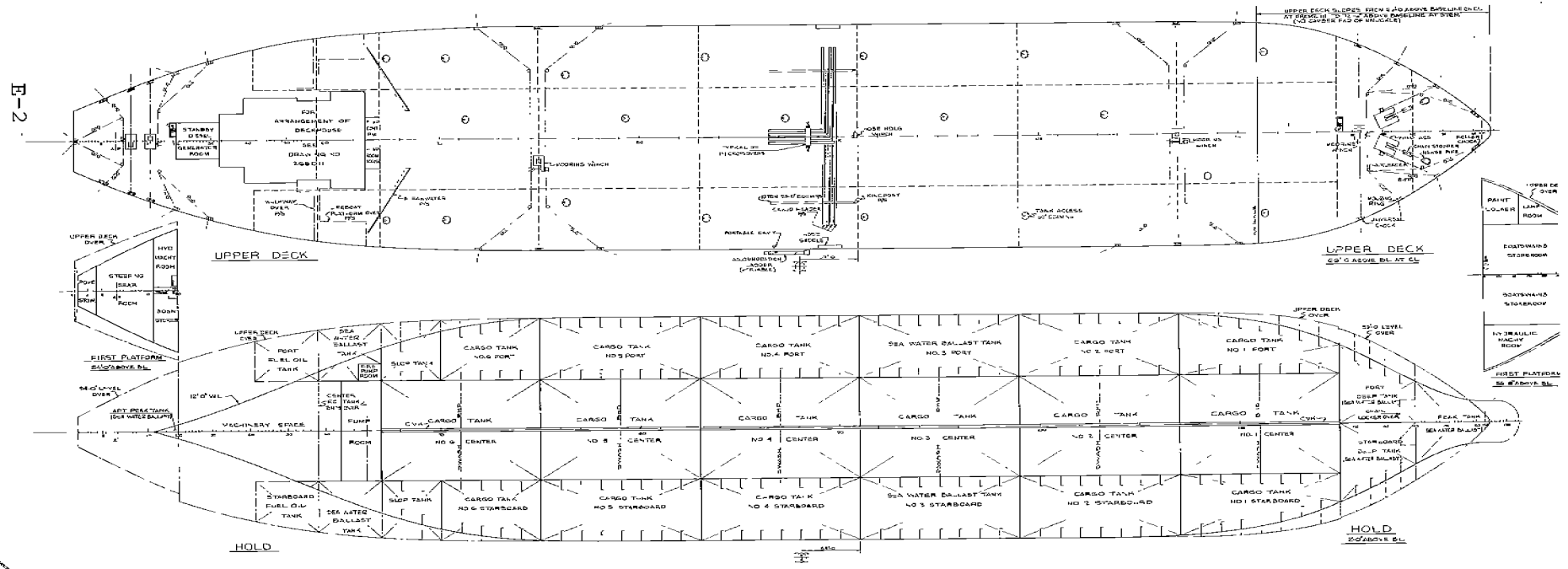

FIGURE E-1

GENERAL ARRANGEMENT DRAWINGS OF VOYAGER CLASS TANKER

486-330

150

NOTE:

1. SCANTLINGS SHOWN ARE TO 1981 ABS RULES.
2. MATERIAL NOT NOTED TO BE ABS-MS.
3. KEY TO WELD SIZES:
 - a. UPPER WELD SIZES ARE FROM EXISTING ABS RULES. THE CIRCLED VALUE IS THE LINE NUMBER FROM THOSE RULES.
 - b. LOWER WELD SIZES ARE FROM PROPOSED WELD SIZE TABLES. THE PERCENTAGE SHOWN IS THE MINIMUM JOINT EFFICIENCY AFTER WELD AND BASE MATERIALS HAVE BEEN CORRODED 0.060 INCH PER SURFACE.

SCANTLING DECKET 48" x 6"

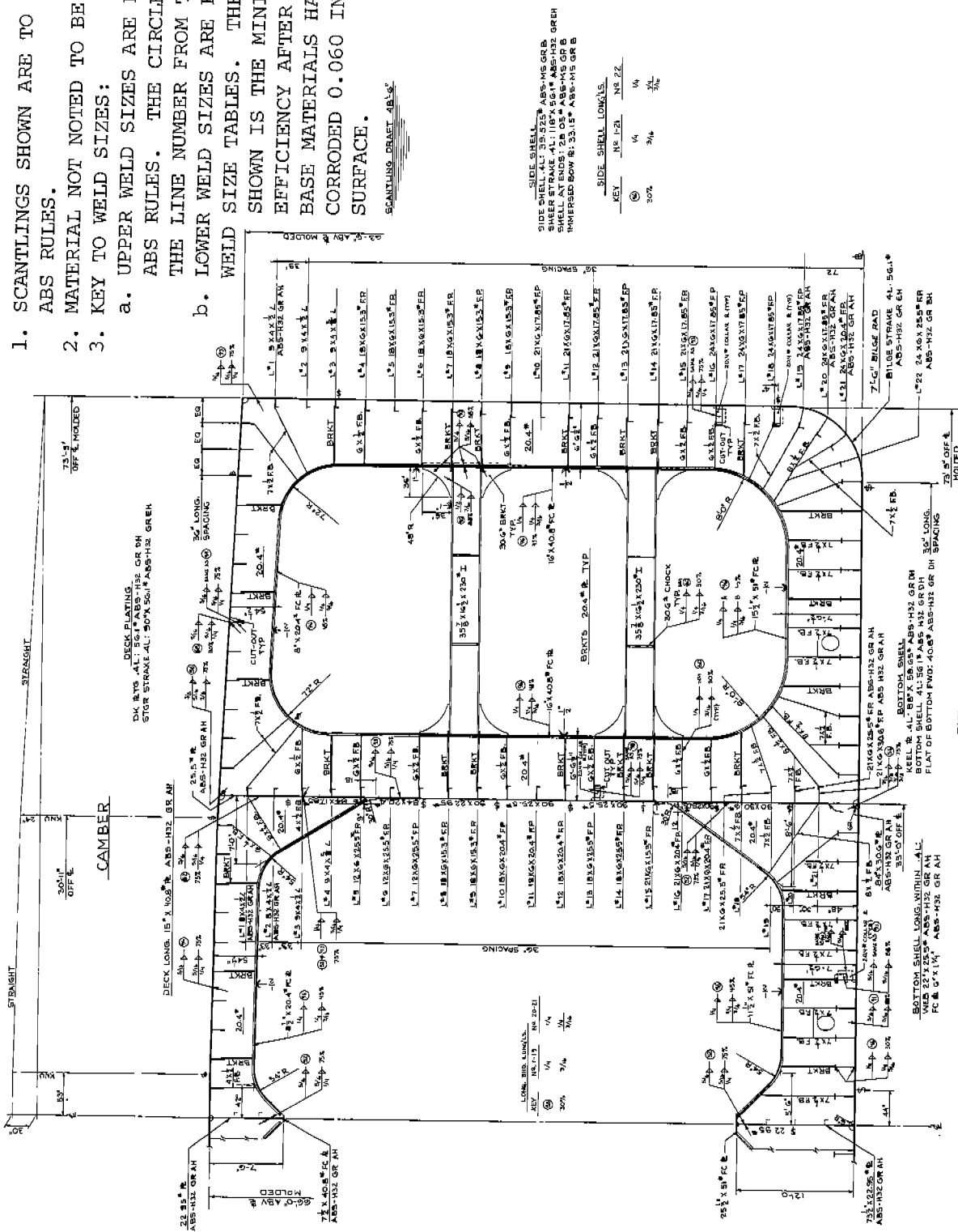

SIDE SHELL

SHEER STRAKE 4L: 1187X 501# ABS-H32 GR SH

SHELL AT ENDS: 28 OS# ABS-H32 GR B

IMPERVED BOW R: 13315# ABS-H32 GR B

SIDE SHELL LOKALS

KEY	NR 1/2	NR 2/2
⊙	1/4	1/4
⊙	3/4	3/4

FIGURE E-2

MIDSHIP SECTION OF VOYAGER CLASS TANKER



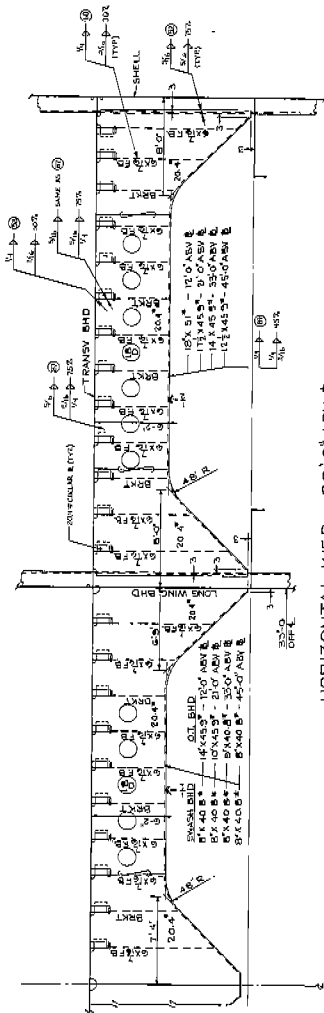

HORIZONTAL WEB - 33'-0" ABV B.
12'-0" 21'-0" & 45'-0" WEB SIMILAR

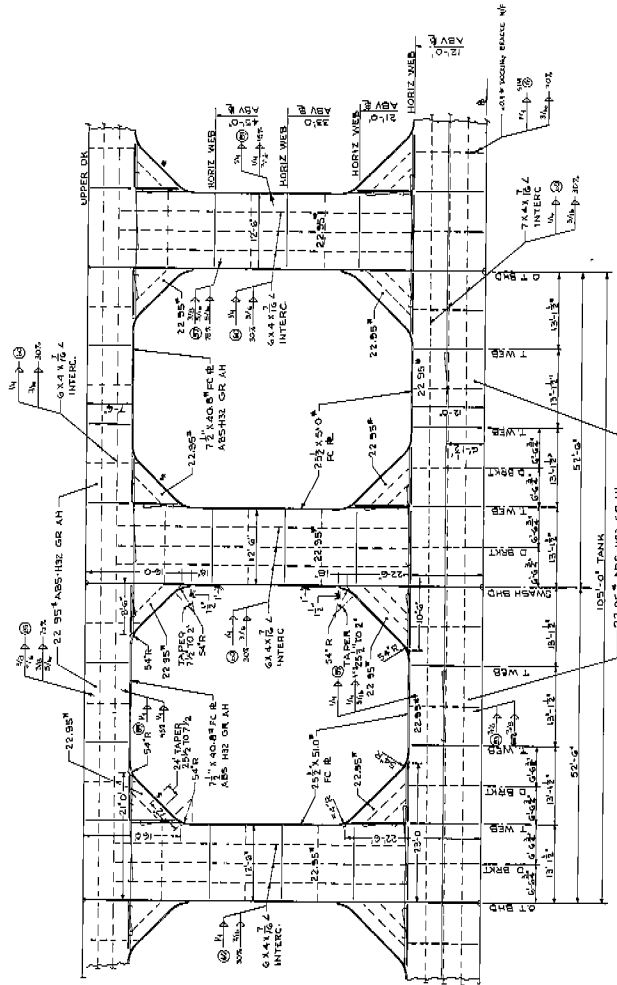

ELEVATION AT ϕ SHIP

FIGURE E-4

VERTICAL, LONGITUDINAL, AND HORIZONTAL GIRDERS OF VOYAGER CLASS TANKER

TABLE E-1

LENGTHS AND WEIGHTS OF ALTERED WELDS FOR VOYAGER CLASS TANKER

STRUCTURAL CONNECTION	Length (Feet)	No.	Total Length of Double Fillet Welds (Feet)	Design Weld Size (Inches)		Weight of Design Welds (Pounds)	
				Existing	Proposed	Existing	Proposed
Deck Longitudinals to deck	630	46	28980	5/16	5/16 1/4	9622	7890
Longitudinal bulkhead to deck	630	2	1260	3/8 5/16	3/8 (2)	510	602
Long. bhd. long'ls 1-19 to bhd.	630	38	23940	1/4	3/16	5087	2862
Long. bhd. long'ls 20-21 to bhd.	630	4	2520	1/4	1/4 3/16	536	418
Side shell long'ls 1-21 to shell	630	42	26460	1/4	3/16	5623	3163
Side shell long'ls 22 to shell	630	2	1260	1/4	1/4 3/16	268	209
Bottom long'ls webs to shell	630	42	26460	1/4	1/4 3/16	5623	4393
Bottom long'ls webs to face plate	630	42	26460	1/4	1/4 3/16	5623	4393
C.V.K. to face plate	630	1	630	1/4	1/4 3/16	134	105
Panel stiff. on centerline girder and C.V.K.	630	5	3150	1/4	3/16	669	377
SUBTOTAL-Long'l. Str. of Cargo Sect.	-	-	141,120	0.265 avg	0.226 avg	33,695	24,412
Deck transv. to deck - inbd.	47.83	36	1722	5/16	5/16 1/4	572	469
Deck transv. to deck - outbd.	57.84	42	2429	5/16	5/16 1/4	807	661
Deck transv. & bhd. transv. to long. bhd.	28.0	36	1008	1/4	5/16 1/4 (2)	214	274
Deck transv. to CL gird. & to long. bhd.	30.0	36	1080	5/16	5/16 1/4	359	294
Deck transv. to deck long.	1.00	1812	1812	5/16	5/16 1/4	602	493
Side transv. to side shell	97.2	42	4082	5/16	5/16 1/4	1355	1111
Side transv. & collar plates to long'ls.	1.20	3696	4435	5/16	5/16 1/4	1473	1208
Bhd. transv. to long. bhd.	90.6	42	3805	5/16	5/16 1/4	1263	1036
Bhd. transv. & collar plates to long. bhd. long'ls.	1.00	3528	3528	5/16	5/16 1/4	1171	961
Bottom transv. to long. bhd. & CVK	62.0	36	2232	5/16	5/16 1/4	741	608
Face plate to transv. - inbd.	158.6	36	5710	1/4	1/4 3/16	1213	948
Face plate to transv. - outbd.	295.4	42	12407	1/4	1/4 3/16	2636	2060
Panel stiff. - inbd.	240.0	36	8640	1/4	3/16	1836	1033
Panel stiff. - outbd.	624.0	42	26208	1/4	3/16	5569	3133
End brackets on struts	44.0	42	1848	1/2	7/16	1571	1203
Chocks on struts	65.4	42	2747	1/4	1/4 3/16	584	456
Docking brackets	34.0	48	1632	1/4	3/16	347	195
SUBTOTAL-Transv. Str. of Cargo Sect.	-	-	85,325	0.277 avg	0.236 avg	22,313	16,143

TABLE E-1, LENGTHS AND WEIGHTS OF ALTERED WELDS FOR VOYAGER CLASS TANKER (Cont'd)

STRUCTURAL CONNECTION	Length (Feet)	No.	Total Length of Double Fillet Welds (Feet)	Design Weld Size (Inches)		Weight of Design Welds (Pounds)	
				Existing	Proposed	Existing	Proposed
O.T. bhd. stiff. to bhd.	62.5	322	20126	1/4	3/16	4277	2406
Horiz. girder webs to O.T. bhd.	100.2	28	2806	5/16	5/16 1/4	932	764
Horiz. girder webs to face plates	160.0	28	4480	1/4	1/4 3/16	952	744
Horiz. girder webs & collar plates to bhd. stiff.	1.00	2576	2576	5/16	5/16 1/4	855	701
Horiz. girder web panel stiff.	276.0	28	7728	1/4	3/16	1642	924
Centerline girder web to O.T. bhd.	46.0	7	322	3/8 5/16	5/16	130	107
Centerline girder web to face plate	27.0	7	189	1/4	1/4 3/16	40	31
Centerline girder web panel stiff.	186.0	7	1302	1/4	3/16	277	156
SUBTOTAL-7 O.T. Bhd's.	-	-	39,529	0.260 avg	0.208 avg	9,105	5,833
Swash bhd. periphery	265.6	6	1594	1/4	3/16	339	191
Swash bhd. stiff. to bhd.	630.0	6	3780	1/4	3/16	803	452
Swash bhd. panel stiff. to bhd.	527.0	6	3162	1/4	3/16	672	378
Horiz. girder webs to swash bhd.	47.4	24	1138	5/16	5/16 1/4	378	310
Horiz. girder webs to face plate	74.0	24	1776	1/4	1/4 3/16	377	295
Horiz. girder webs & collar plates to bhd. stiff.	1.00	960	960	5/16	5/16 1/4	319	262
Horiz. girder web panel stiff.	120.0	24	2880	1/4	3/16	612	344
Centerline girder web to swash bhd.	46.0	6	276	3/8 5/16	5/16	112	92
Centerline girder web to face plate	27.0	6	162	1/4	1/4 3/16	34	27
Centerline girder web panel stiff.	186.0	6	1116	1/4	3/16	237	133
SUBTOTAL-6 Swash Bhd's.	-	-	16,844	0.260 avg	0.208 avg	3,883	2,484
SUBTOTAL-All Cargo Sect. Structure	-	-	282,818	0.268 avg	0.225 avg	68,996	48,872
ESTIMATE FOR BOW, STERN AND DECKHOUSE ⁽¹⁾	-	-	59,392	0.268 avg	0.225 avg	14,504	10,223
TOTALS	-	-	342,210	0.268 avg	0.225 avg	83,500	59,095

NOTE: (1) The 630 foot long cargo section is assumed to be prismatic. Therefore, the length and weight estimates for the cargo section should be slightly high. This is compensated for by deliberately underestimating weld lengths and weights for the bow, stern, and deckhouse.
 (2) Proposed weld sizes which are increased from existing values are highlighted by reference to this note.

952

155

TABLE E-2

LENGTHS AND WEIGHTS OF UNALTERED WELDS FOR VOYAGER CLASS TANKER

STRUCTURAL CONNECTION	Length (Feet)	No.	Total Length of Double Fillet Welds (Feet)	Design Weld Size (Inches)	Weight of Design Welds (Pounds)
Centerline girder web to deck	630	1	630	$\frac{3}{8}$ $\frac{5}{16}$	255
Centerline girder web to face plate	582	1	582	1/4	124
Longitudinal bulkhead to bot. shell	630	2	1260	$\frac{7}{16}$ $\frac{3}{8}$	711
C.V.K. to shell	630	1	630	3/8	301
SUBTOTAL-Long'l. Str. of Cargo Sect.	-	-	3,102	0.363 avg.	1,391
Side transv. collar plate lap welds	1.37	1848	2532	5/16	841
Bhd. transv. collar plate lap welds	1.17	1764	2064	5/16	685
Bottom transv. to shell - inboard	47.83	36	1722	5/16	572
Bottom transv. to shell - outboard	57.84	42	2429	5/16	807
Bot.transv.& collar plates to long.	1.50	3288	4932	5/16	1638
Bot.transv. collar plate lap welds	1.67	1644	2745	5/16	911
End brackets on struts	96.0	42	4032	5/16	1339
SUBTOTAL-Transv.Str. of Cargo Sect.	-	-	20,456	0.313 avg.	6,793

952

486-330

156

TABLE E-2, LENGTHS AND WEIGHTS OF UNALTERED WELDS FOR VOYAGER CLASS TANKER (Cont'd)

STRUCTURAL CONNECTION	Length (Feet)	No.	Total Length of Double Fillet Welds (Feet)	Design Weld Size (Inches)	Weight of Design Welds (Pounds)
O.T. bhd. periphery inc. collar plates	555.5	7	3888	$\frac{3}{8}$ $\frac{5}{16}$	1575
O.T. bhd. periphery inc. collar plates	125.0	7	875	$\frac{5}{16}$ $\frac{1}{4}$	238
O.T. bhd. periphery inc. collar plates	120.0	7	840	5/16	279
O.T. bhd. periphery inc. collar plates	138.0	7	966	3/8	462
O.T. bhd. periphery inc. collar plates	947.5	7	6632	$\frac{7}{16}$ $\frac{3}{8}$	3743
Horiz. girder web collar plate lap welds	1.17	1288	1507	5/16	500
Horiz. girder web end connections	104.0	7	728	5/16	242
SUBTOTAL-7 O.T. Bulkheads	-	-	15,436	0.366 avg.	7,039
Swash bhd. & collar plates to bot. long.	1.50	240	360	5/16	120
Bot. long. collar plate lap welds	1.67	120	200	5/16	66
Girder collar plate lap welds	1.17	480	562	5/16	187
Horiz. girder web end connections	52.0	6	312	5/16	104
SUBTOTAL-6 Swash Bulkheads	-	-	1,434	0.313 avg.	477
SUBTOTAL-All Cargo Section Struct.	-	-	40,428	0.338 avg.	15,700
ESTIMATE FOR BOW, STERN, AND DECKHOUSE	-	-	8,490	0.338 avg.	3,298
TOTALS	-	-	48,918	0.338 avg.	18,998

952

486-330

157

MIDSHIP SECTION - 1981 ABS RULES

(Terms are as defined in ABS Rules unless noted otherwise)

Principal Dimensions

LOA 950'-0"
 LWL 925'-0"
 LBP 900'-0"
 B 147'-6"
 D 63'-6"
 d 48'-6"

Weights (Long Tons)

Light Ship		22,200
Fuel Oil	4,600	
D.O. & L.O.	60	
Fresh water	280	
Crew & Stores	50	
Cargo	120,200	
TOTAL DEADWEIGHT		125,190
DISPLACEMENT		147,390

REQUIRED SECTION MODULUS - MILD STEEL

Section 2.1 Scantling length = L = 0.97 x LWL = 897.25'

Section 6.3.1(a) $SM = M_t / f_p$
 $f_p = 10.56 + \frac{L-790}{2045} = 10.612 \text{ LT/in}^2$

Section 6.3.1(b) $C_1 = 0.01441 \left[10.75 - \left(\frac{984-L}{328} \right) 1.5 \right] = 0.15295$
 $C_b = \frac{\text{Displacement} \times 35 \text{ ft}^3/\text{LT}}{L \times B \times d} = 0.80375$

Min. SM = $0.01 C_1 L^2 B (C_b + 0.7) = 273,114 \text{ in}^2 \text{ ft}$

Section 6.3.2.(a) $C_{st} = \left[0.275 - \frac{L-820}{11,600} \right] 10^{-3} = 0.26834 \times 10^{-3}$

$M_{sw} = C_{st} L^{2.5} B (C_b + 0.5) = 1,244,387 \text{ Ft-LT}$

Section 6.3.2(b) $K_b = 1.0$
 $C_2 = [6.53 C_b + 0.57] 10^{-4} = 5.8185 \times 10^{-4}$
 $H_e = [4.50 L - 0.00216 L^2 + 335] 10^{-2} = 26.337 \text{ ft}$
 $M_w = C_2 L^2 B H_e K_b = 1,819,700 \text{ ft-LT}$
 $M_t = M_{sw} + M_w = 3,064,087 \text{ ft-LT}$
 $SM = M_t / f_p = 288,738 \text{ in}^2 \text{ ft}$ (97 and 95% of 1970
 ABS Rules Deck and Baseline values)

REQUIRED MOMENT OF INERTIA AND SECTION MODULUS - H32 STEEL

Section 6.13.2 $I_{H32} = L \times SM/34.1 = 7,597,400 \text{ in}^2 \text{ ft}^2$

Table 43.2 $Y = \text{Yield Stress} = 45,500 \text{ PSI}$

$U = \text{Ultimate Tensile Stress} = 68,000 \text{ PSI}$

Section 6.13.3 $Q = 70,900/(Y + 2U/3) = 0.78050$

$SM_{H32} = Q(SM) = 225,360 \text{ in}^2 \text{ ft}$

SCANTLINGS

Use H32 material in deck and bottom structure with mild steel elsewhere.

Reduce deck longitudinal from 15" x 1.25" to 15" x 1.00"

Reduce bottom longitudinal flanges from 6" x 1.375" to 6" x 1.25"

Resulting properties:

$I = 7,850,007 \text{ in}^2 \text{ ft}^2 > 7,597,400 \text{ in}^2 \text{ ft}^2$

$SM_{dk} = 240,281 \text{ in}^2 \text{ ft} > 225,360 \text{ in}^2 \text{ ft}$

$SM_{FL} = 254,622 \text{ in}^2 \text{ ft} > 225,360 \text{ in}^2 \text{ ft}$

MAXIMUM HULL GIRDER SHEARING FORCE

Section 6.3.3(a) $V_p = F_{sw} + F_w$

Section 6.3.3(b) $V_p = 5.0 M_{sw}/L + 2.6 M_w/L = 12,207^{LT}$

VON MISES COMBINED STRESS ANALYSIS FOR BOTTOM LONGITUDINALS

Bottom longitudinals are built up sections with 22" x 0.625" AH32 webs, 6" x 1.25" AH32 flanges, 36" spacing on 56.1# DH32 bottom plate, and spans of 13'-1.5".

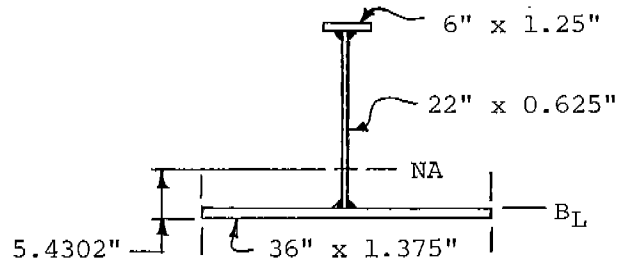

PRIMARY STRESSES

ABS Rule Loading: Total bending moment = 3,064,087 ft-LT
 Hull girder shearing force = 12,207 LT

Longitudinal Stresses:

$$\sigma_x @ B_L = \frac{3,064,087 \text{ ft-LT} \times 2240 \text{ \#/LT}}{254,622 \text{ in}^2 \text{ ft}} = 26,956 \text{ PSI}$$

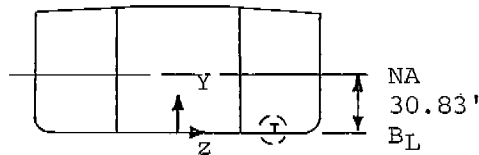

$$\sigma_x = -25,262 \text{ PSI}$$

$$-25,353 \text{ PSI}$$

$$-26,956 \text{ PSI}$$

$$-27,056 \text{ PSI}$$

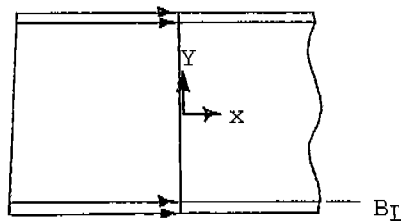

Longitudinal Stresses

(Hogging condition shown - reverse for sagging condition)



Primary Shear Stresses: The upper surface of the flange is a free surface so the shear stress must be zero and shear stresses within the web may be calculated from:

$$\tau_{xy} = \frac{V_p (AY)_p}{I_p T} = \frac{12,207 \text{ LT} \times 2240 \text{ \#/LT} \times (AY)_p}{7,850,007 \text{ in}^2 \text{ ft}^2 \times 0.625 \text{ in.}} = 5.5732 (AY)_p \frac{\#}{\text{in}^3 \text{ ft}^2}$$

Point	(AY) _p (in ft ²)	τ _{xy} (PSI)
Web at Flange	18.090	101
Web at NA	45.890	256
Web at Shell	52.366	292

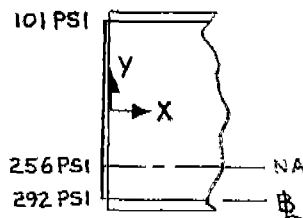

SECONDARY STRESSES

ABS Rule Loading: From Section 22.29.2, design head is 8' above deck at side which is 71.5' above baseline. Because the longitudinals are continuous through all transverse supporting structure and the loading is symmetric, the longitudinals can be considered as fixed ended beams. External load shown, reverse all signs for internal load.

SECTION PROPERTIES:

Area = 70.75 in²
 I_{NA} = 4926.22 in⁴
 Z_{flg} = 256.64 in³
 Z_{plt} = 907.19 in³
 (AY)_s for web at flg = 139.27 in³
 (AY)_s for web at NA = 239.90 in³
 (AY)_s for web at shell = 234.76 in³

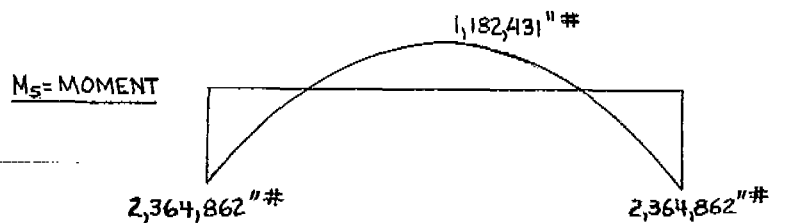
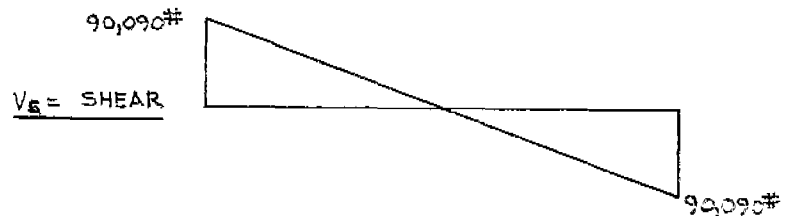
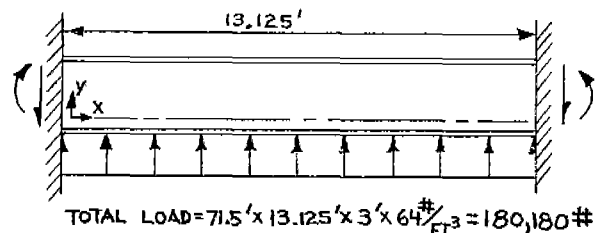

Longitudinal Stresses = M_s/Z

Shear Stresses in Web = $\frac{V_s (AY)_s}{I_{NA} T}$

In addition to longitudinal and shear stresses, there is a compressive stress in the web varying from near zero at the flange to a maximum value at the shell of about:

$\sigma_y = \frac{71.5' \times 3' \times 64\#/Ft^3}{0.625" \times 12"/'} = 1830 \text{ PSI}$

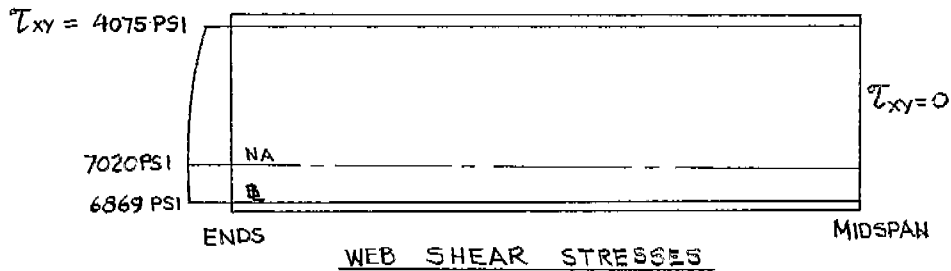
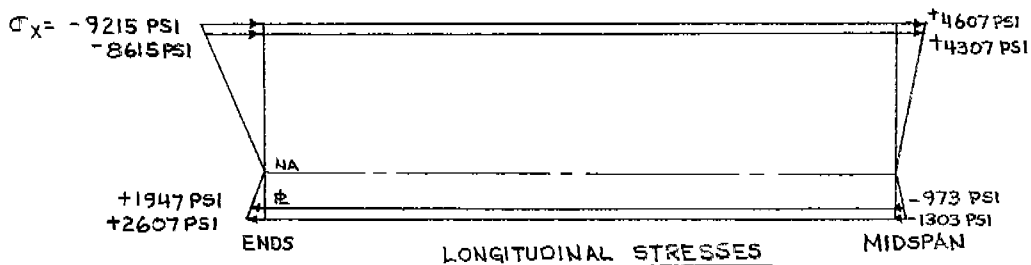

COMBINED PRIMARY AND SECONDARY STRESSES IN WEB - CASE I

Hogging condition with external secondary load shown - reverse all signs for sagging condition with internal secondary load.

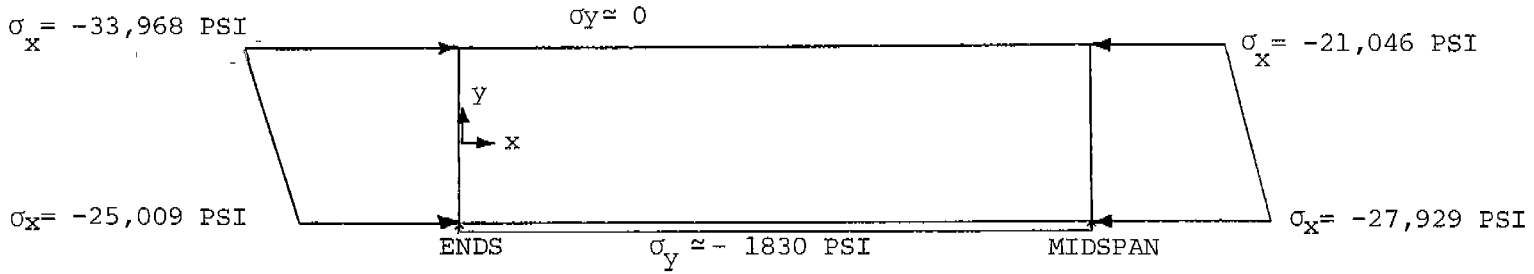

COMBINED NORMAL STRESSES

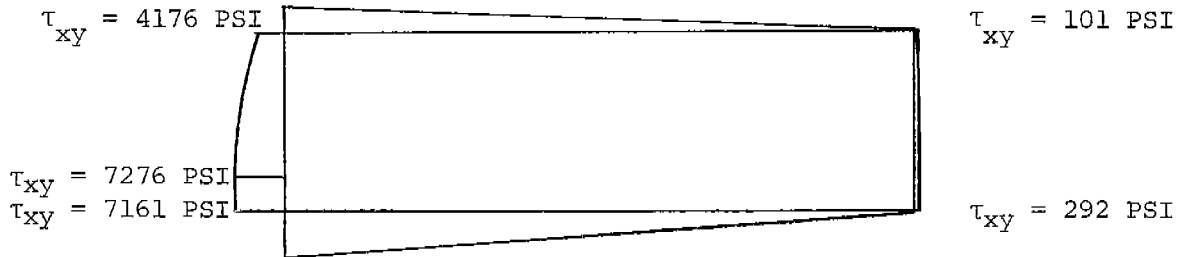

COMBINED SHEAR STRESSES

90%

486-330

163

COMBINED PRIMARY AND SECONDARY STRESSES IN WEB - CASE II

Hogging condition with internal secondary load shown - reverse all signs for sagging condition with external secondary load.

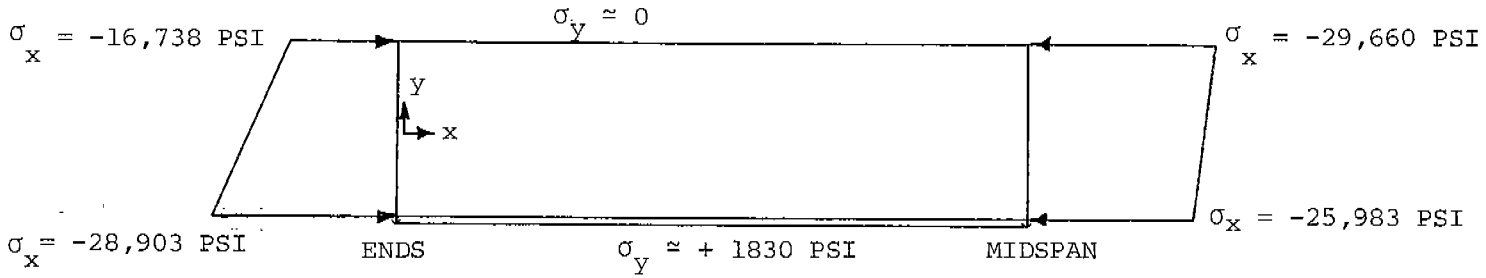

COMBINED NORMAL STRESSES

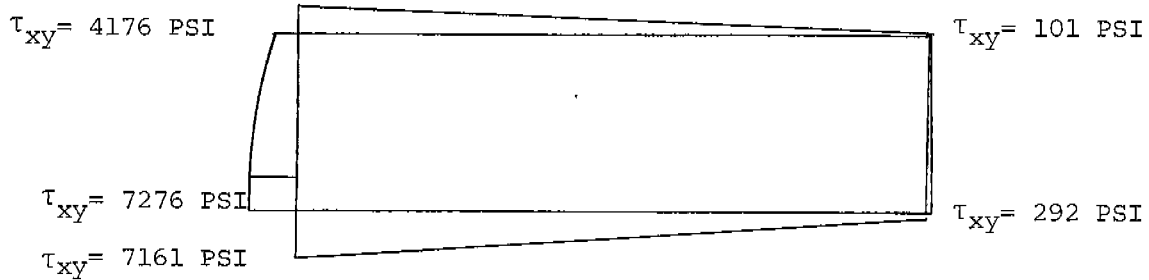

COMBINED SHEAR STRESSES



VON MISES COMBINED STRESSES

In terms of principal stresses σ_1 and σ_2 , the two dimensional von Mises criteria states that yielding will occur when the following combination of principal stresses reach the yield stress, Y :

$$\sigma_1^2 + (\sigma_1 - \sigma_2)^2 + \sigma_2^2 = 2Y^2$$

$$\text{or } \sigma_1^2 - \sigma_1 \sigma_2 + \sigma_2^2 = Y^2$$

For the two dimensional case at hand, the principal stresses are:

$$\sigma_{1,2} = 1/2 (\sigma_x + \sigma_y) \pm \sqrt{[1/2(\sigma_x + \sigma_y)]^2 + \tau_{xy}^2}$$

These two equations can be combined to express the von Mises criteria in terms of σ_x , σ_y , and σ_{xy} directly:

$$\sigma_x^2 - \sigma_x \sigma_y + \sigma_y^2 + 3 \tau_{xy}^2 = Y^2$$



WELD REQUIRED FOR WEB TO FLANGE CONNECTION USING
VON MISES COMBINED STRESS CRITERIA

The Case I load combination is the most severe for this connection.

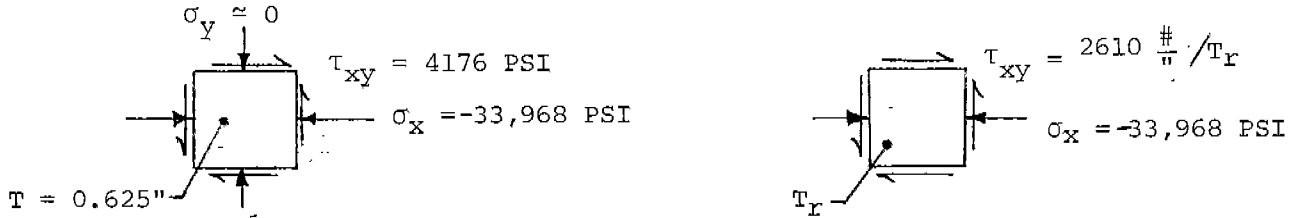

When determining a required web thickness, T_r , on which to base the fillet weld, it should be noted that only τ_{xy} would vary significantly if the web thickness in way of the flange were locally altered as shown below. The longitudinal stress would remain essentially constant. Material is AH32 plate with yield stress = $Y = 45,500$ PSI.

$$\sigma_x^2 - \sigma_x \sigma_y + \sigma_y^2 + 3 \tau_{xy}^2 = Y^2$$

$$(-33,968)^2 - (-33,968)(0) + (0)^2 + 3 \left(\frac{2610}{T_r} \right)^2 = (45,500)^2$$

$$T_r = 0.1400''$$

Required fillet weld size is:

$$D = 0.668(0.1400'') + 0.085'' = 0.1785''$$

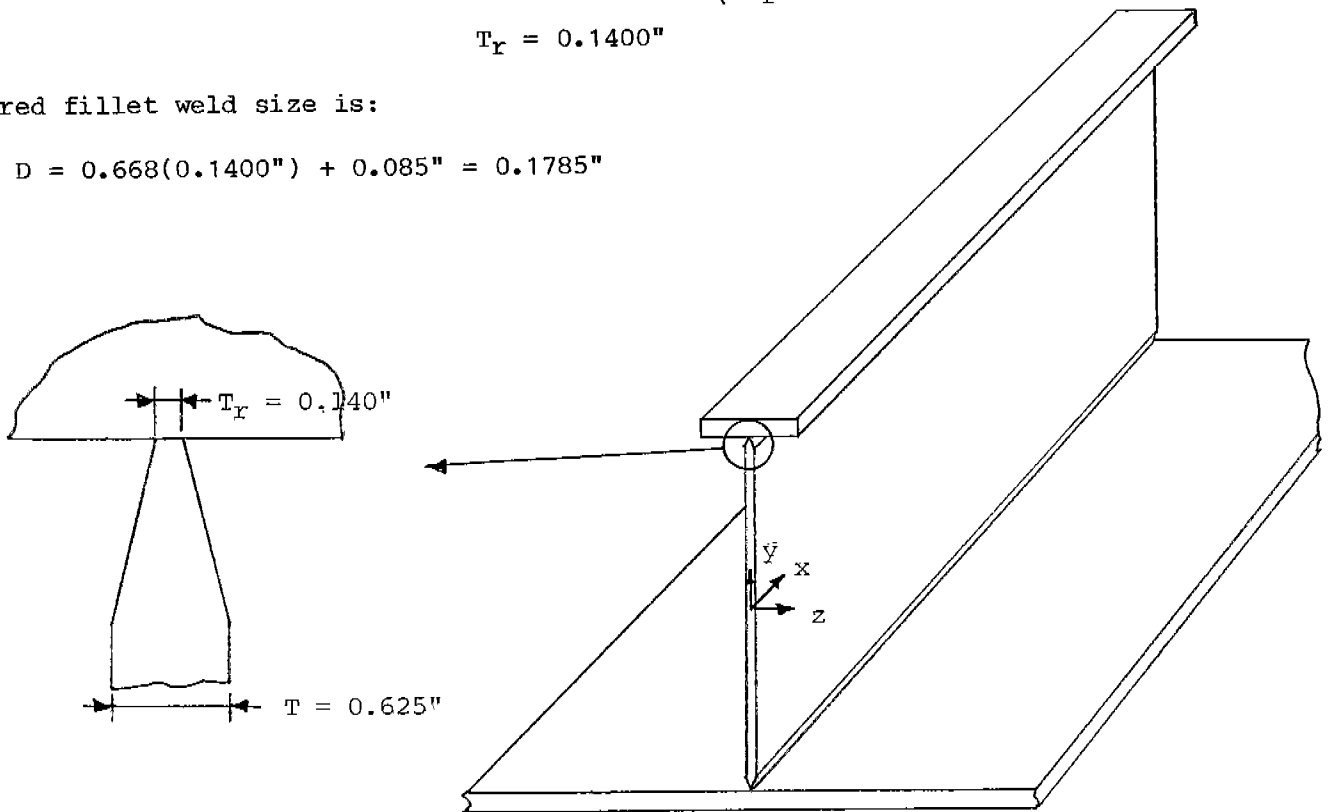

WELD REQUIRED FOR WEB TO SHELL PLATING CONNECTION USING
VON MISES COMBINED STRESS CRITERIA

Case II load combination is the most severe for this connection.

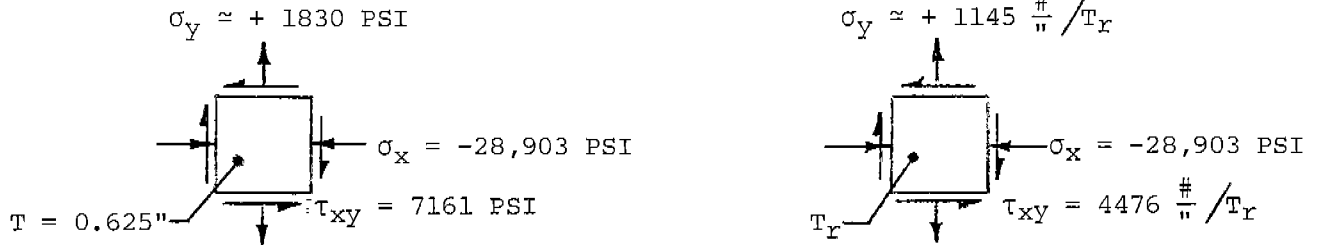

In this case, both σ_y and τ_{xy} will vary significantly if the web thickness in way of the shell plating were altered.

$$\sigma_x^2 - \sigma_x \sigma_y + \sigma_y^2 + 3 \tau_{xy}^2 = \sigma_y^2$$

$$(-28,903)^2 - (-28,903) \left(+ \frac{1145}{T_R} \right) + \left(+ \frac{1145}{T_R} \right)^2 + 3 \left(\frac{4476}{T_R} \right)^2 = (45,500)^2$$

$$T_R^2 - 0.026800 T_R - 0.049734 = 0$$

$$T_R = 0.23681 \text{ inches}$$

$$D = 0.668(0.23681 \text{ inches}) + 0.085 \text{ inches} = 0.2432 \text{ inches}$$

These two welds are covered by line 46 which falls in ABS weld groups M and M4.
ABS weld size is $7/32 \text{ inches} = 0.2188 \text{ inches}$,
or $5/16 \text{ inches}$ 3-10 which has an equivalent weld size of 0.1532 inches

Therefore, this analysis procedure is excessively conservative. One of the reasons for this conservatism is that the Von Mises criteria defines initial yielding only, not necessarily ultimate failure. For example, the von Mises criteria for pure shear gives an allowable shear stress of 57.7% of the uniaxial tensile yield stress. However, tests show that the ultimate shear stress of most steels can be 67 to 75% of the uniaxial tensile ultimate stress. Since the weld strength values are necessarily breaking strengths, a higher ratio than 57.7% for shear to tensile strength is appropriate. Various attempts to modify the von Mises criteria to more accurately reflect experimental failure data have been suggested. For example, reference (15), page 69, shows a τ_{xy} coefficient of 1.8 rather than 3. The value of 1.8 gives an allowable shear stress of 74.5% of the uniaxial tensile stress which is more in line with experimental results.

WELD REQUIRED FOR WEB TO FLANGE CONNECTION USING
MODIFIED VON MISES COMBINED STRESS CRITERIA

$$\sigma_x^2 - \sigma_x \sigma_y + \sigma_y^2 + 1.8 \tau_{xy}^2 = Y^2$$

$$(-33,968)^2 - (-33,968)(0) + (0)^2 + 1.8 \left(\frac{2610}{T_r} \right)^2 = (45,500)^2 \quad (\text{see page E-18})$$

$$T_r = 0.11567''$$

$$D = 0.668 (0.11567'') + 0.085'' = 0.1623''$$

WELD REQUIRED FOR WEB TO SHELL PLATING CONNECTION USING
MODIFIED VON MISES COMBINED STRESS CRITERIA

$$\sigma_x^2 - \sigma_x \sigma_y + \sigma_y^2 + 1.8 \tau_{xy}^2 = Y^2$$

$$(-28,903)^2 - (-28,903) \left(+ \frac{1145}{T_r} \right) + \left(+ \frac{1145}{T_r} \right)^2 + 1.8 \left(\frac{4476}{T_r} \right)^2 = (45,500)^2$$

(See page E-19)

$$T_r^2 - 0.026800 T_r - 0.030265 = 0$$

$$T_r = 0.18788''$$

$$D = 0.668 (0.18788'') + 0.085'' = 0.2105''$$

This calculation gives a weld size less than ABS continuous weld of 0.2188" but still greater than the ABS intermittent weld equivalent size of 0.1532".



SIMPLIFIED STRESS ANALYSIS PROCEDURES

For members where the most significant stresses in the fillet welds are longitudinal shear, the required thickness, T_r , can be determined as follows:

$$\tau_T = \tau_p + \tau_s$$

$$\tau_T = \frac{V_p(AY)_p}{I_p T_r} + \frac{V_s(AY)_s}{I_s T_r}$$

or

$$T_r = \frac{1}{\tau_T} \left[\frac{V_p(AY)_p}{I_p} + \frac{V_s(AY)_s}{I_s} \right]$$

where: V = Shear Force

AY = Area moment about appropriate neutral axis

I = Moment of inertia

Subscripts p and s refer to primary and secondary values, respectively.

To use these equations, allowable shear stresses are needed. Fortunately, the ABS Rules give the majority of the required values. Those that are missing can be conservatively taken as 60% of the respective tensile stresses.

ABS ALLOWABLE STRESSES FOR VOYAGER CLASS TANKER

PRIMARY STRESSES

From Section 6.3.1(a) for an 897.25' ship, $f_p = \sigma_p = 10.612 \text{ LT/in}^2 = 23,771 \text{ PSI}$
 From Section 6.3.3, $\tau_p = 6.75 \text{ LT/in}^2 = 15,120 \text{ PSI}$ (63.6% of σ_p)

<u>Material</u>	<u>Q</u>	$\sigma_p = \frac{23,771 \text{ PSI}}{Q}$	$\tau_p = \frac{15,120 \text{ PSI}}{Q}$
MS	1.0	23,771	15,120
H32	0.7805	30,456	19,372
H36	0.7210	32,969	20,971

SECONDARY STRESSES FOR TRANSVERSE STRUCTURE (WEBS, GIRDERS, AND TRANSVERSES)

From Section 22.27.2, $f = \sigma_s = 9 \text{ LT/in}^2 = 20,160 \text{ PSI}$
 From Section 22.27.4, $q = \tau_s = 5.5 \text{ LT/in}^2 = 12,320 \text{ PSI}$ (61.1% of σ_p)

<u>Material</u>	<u>Q</u>	$\sigma_s = \frac{20,160 \text{ PSI}}{Q}$	$\tau_s = \frac{12,320 \text{ PSI}}{Q}$
MS	1.0	20,160	12,320
H32	0.7805	25,830	15,785
H36	0.7210	27,961	17,087

SECONDARY AND COMBINES STRESSES FOR LONGITUDINAL STRUCTURE (WEBS AND GIRDERS)

From Section 22.27.2, $f = \sigma_s = 6 \text{ LT/in}^2 = 13,440 \text{ PSI}$
 From Section 22.27.4, $q = \tau_s = 4.4 \text{ LT/in}^2 = 9,856 \text{ PSI}$ (73.3% of σ_p)

<u>Material</u>	<u>Q</u>	$\sigma_s = \frac{13,440 \text{ PSI}}{Q}$	$\frac{\sigma_T}{\sigma_s + \sigma_p}$	<u>Y (PSI)</u>	$\frac{\sigma_T}{\text{VS. Y}}$	$\tau_s = \frac{9856 \text{ PSI}}{Q}$	$\frac{\tau_T}{\tau_s + \tau_p}$	$\frac{\tau_T}{\sigma_T}$
MS	1.0	13,440	37,211	34,000	+ 9.4%	9,856	24,976	67.1%
H32	0.7805	17,220	47,676	45,500	+ 4.8%	12,628	32,000	67.1%
H36	0.7210	18,641	51,610	51,000	+ 1.2%	13,670	34,641	67.1%



SECONDARY AND COMBINED STRESSES FOR STRUCTURAL SECTIONS

From Section 22.29.2,

$SM = 0.0041 c h s L^2$ (in³) where c varies with location
 h = hydrostatic head in feet
 s = spacing in feet
 L = length between supports in feet.

Consider a fixed end, uniformly loaded beam.

Maximum bending moment is at supports with value:

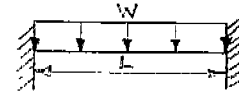

$BM = w L^2 / 12$

$w = \text{unit load} = \text{pressure} \times \text{spacing} = h \text{ (feet)} \times 64 \text{ lbs/ft}^3 \times$

$S \text{ (feet)} = 64 h s \text{ lbs/ft}$

$\sigma_s = \frac{BM}{SM}$ or $SM = \frac{BM}{\sigma_s}$

$SM = \frac{wL^2}{12 \sigma_s} = \frac{64 h s \text{ (lbs/Ft)} L^2 \text{ (Ft}^2) \times 12 \text{ in/Ft}}{12 \sigma_s \text{ (lbs/in}^2)} = \frac{64 h s L^2}{\sigma_s} \text{ (in}^3)$

Equating the two SM expressions,

$0.0041 c h s L^2 = \frac{64 h s L^2}{\sigma_s}$

$\sigma_s = \frac{64}{0.0041c}$

$\sigma_s = \frac{15,610 \text{ PSI}}{c}$

MILD STEEL STRUCTURAL SECTIONS

Location	c	$\frac{\sigma_s = 15,610}{c}$	$\sigma_T = \sigma_s + 23,771$	σ_T vs. 34,000	$\tau_s = 0.6 \times \sigma_s$	$\tau_T = \tau_s + 15,120$	$\frac{\tau_T}{\sigma_T}$
Dk. Long.	1.25	12,488	36,259	+ 6.6%	7,493	22,613	62.4%
Side Long.	0.95	16,431	<40,202	-	9,859	<24,979	-
Horiz. Stiff. on Long. Bhd.	0.90	17,344	<41,115	-	10,406	<25,526	-
Bottom Long.	1.40	11,150	34,921	+ 2.7%	6,690	21,810	62.5%
Vert. Frames Transv. Bhd. Stiff.	1.00	15,610	-	-	9,366	-	-
	1.00	15,610	-	-	9,366	-	-

H32 STRUCTURAL SECTIONS (Q=0.7805)

<u>Location</u>	<u>c</u>	$\frac{\sigma_s = 15,610}{c \times 0.7805}$	$\frac{\sigma_T = 30,456}{\sigma_s + 30,456}$	$\frac{\sigma_T \text{ vs. } 45,500}{\sigma_T \text{ vs. } 45,500}$	$\frac{\tau_s = 0.6 \times \sigma_s}{0.6 \times \sigma_s}$	$\frac{\tau_T = 19,372}{\tau_s + 19,372}$	$\frac{\tau_T}{\sigma_T}$
Dk. Long.	1.25	16,000	46,456	+ 2.1%	9,600	28,972	62.4%
Side Long.	0.95	21,053	<51,509	-	12,632	<32,004	-
Horiz. Stiff. on Long.							
Bhd.	0.90	22,222	<52,678	-	13,333	<32,705	-
Bottom Long.	1.40	14,286	44,742	- 1.7%	8,572	27,944	62.5%
Vert. Frames	1.00	20,000	-	-	12,000	-	-
Transv. Bhd. Stiff.	1.00	20,000	-	-	12,000	-	-

H36 STRUCTURAL SECTIONS (Q=0.7210)

<u>Location</u>	<u>c</u>	$\frac{\sigma_s = 15,610}{c \times 0.7210}$	$\frac{\sigma_T = 32,969}{\sigma_s + 32,969}$	$\frac{\sigma_T \text{ vs. } 51,000}{\sigma_T \text{ vs. } 51,000}$	$\frac{\tau_s = 0.6 \times \sigma_s}{0.6 \times \sigma_s}$	$\frac{\tau_T = 20,971}{\tau_s + 20,971}$	$\frac{\tau_T}{\sigma_T}$
Dk. Long.	1.25	17,320	50,289	- 1.4%	10,392	31,363	62.4%
Side Long.	0.95	22,790	<55,759	-	13,674	<34,645	-
Horiz. Stiff. on Long.							
Bhd.	0.90	24,056	<57,025	-	14,434	<35,405	-
Bottom Long.	1.40	15,465	48,434	- 5.0%	9,279	30,250	62.5%
Vert. Frames	1.00	21,650	-	-	12,990	-	-
Transv. Bhd. Stiff.	1.00	21,650	-	-	12,990	-	-

SIMPLIFIED STRESS ANALYSIS FOR BOTTOM LONGITUDINALS

From Page E-13, $V_p = 12,207$ LT = 27,343,680#
(AY)_p for web at flange = 18.090 in. Ft²
(AY)_p for web at shell = 52.366 in. Ft²
 $I_p = 7,850,007$ in² Ft²

From Page E-13, $V_s = 90,090$ #
(AY)_s for web at flange = 139.27 in³
(AY)_s for web at shell = 234.76 in³
 $I_s = 4926.22$ in⁴

From Page E-24, τ_T for H32 bottom long. = 27,944 PSI

For web to flange connection,

$$\tau_r = \frac{1}{\tau_T} \left[\frac{V_p (AY)_s}{I_p} + \frac{V_s (AY)_s}{I_s} \right]$$
$$\tau_r = \frac{1}{27,944 \text{ \#/in}^2} [63.012 \text{ \#/in.} + 2546.95 \text{ \#/in.}] = 0.09340 \text{ in.}$$
$$D = 0.668 (0.09340") + 0.085" = 0.1474"$$

For web to shell connection,

$$\tau_r = \frac{1}{27,944 \text{ \#/in}^2} [182.40 \text{ \#/in.} + 4293.26 \text{ \#/in.}] = 0.16017 \text{ in.}$$
$$D = 0.668 (0.16017") + 0.085" = 0.1920"$$

From the comparison on the next page, this procedure matches the existing ABS rule tables much better than the von Mises combined stress analysis does. Hence, it should be sufficiently conservative for normal use. Also, the web to flange welds are not as highly loaded as the web to shell welds, so some further reduction in the former weld size would appear feasible if these welds were not already at the minimum acceptable size (see Section 5.5).

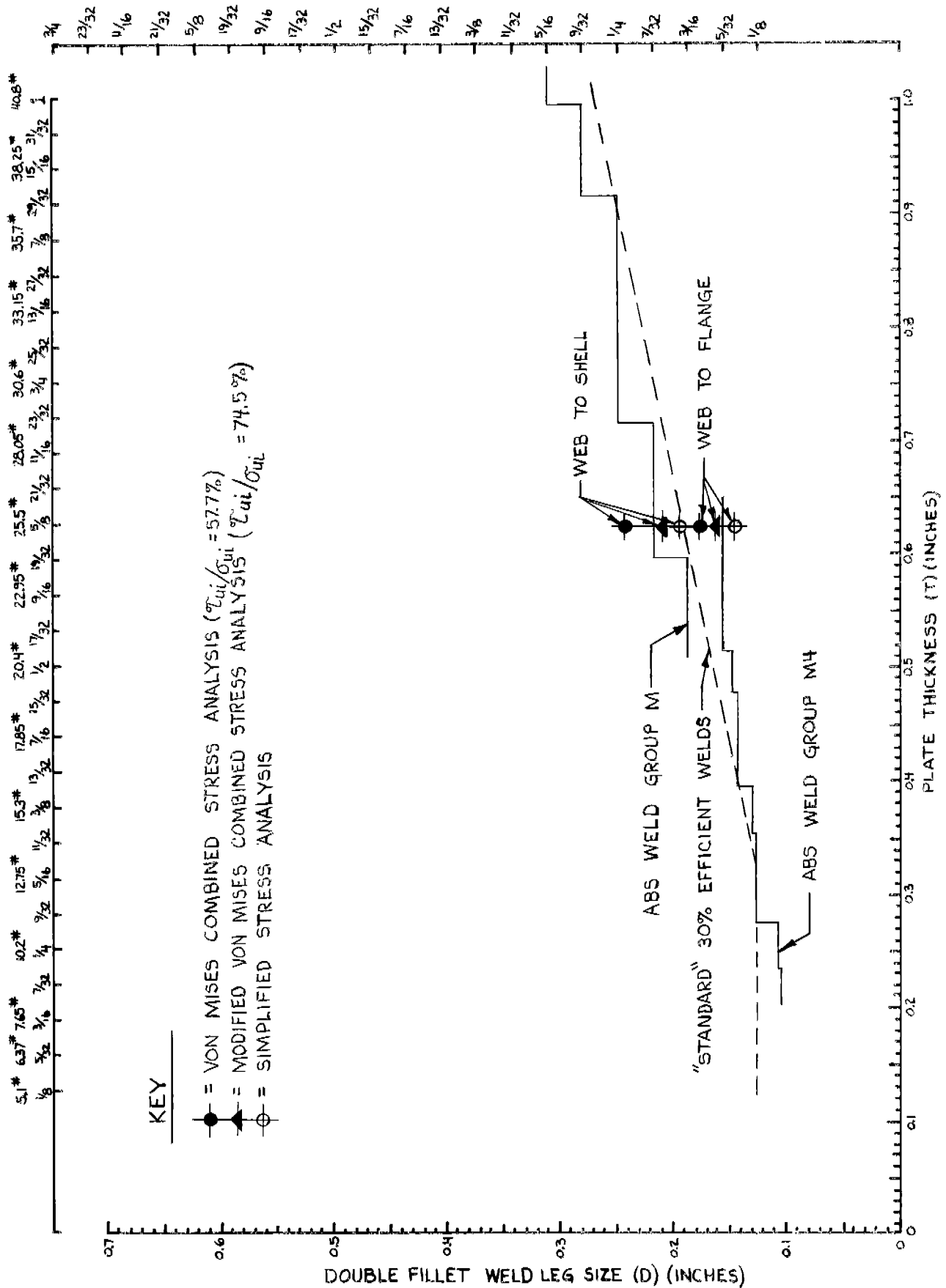
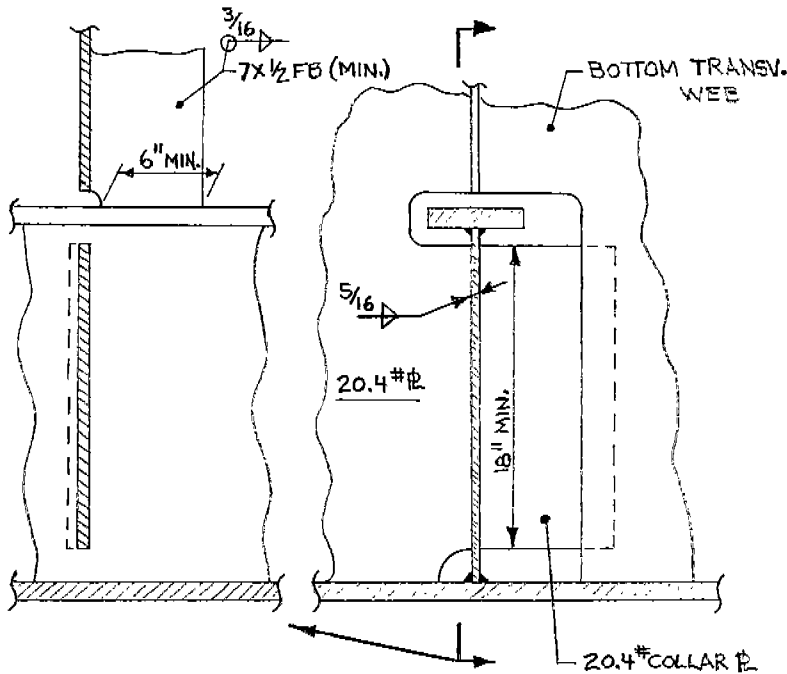

FIGURE E-5

COMPARISON OF CALCULATED AND TABULAR WELD SIZES FOR BOTTOM LONGITUDINALS OF VOYAGER CLASS TANKER

486-330 - (174) N

CONNECTION OF BOTTOM LONGITUDINALS TO SUPPORTING STRUCTURE



SECTION LOOKING FORWARD

The most significant load on this connection is due to the secondary load on the longitudinals. From page E-13, the local force on the supporting structure is $2 \times 90,090\#$. There will also be shear forces in the bottom transverse webs which vary in magnitude at each longitudinal location. The maximum design shear stress from the latter forces is 12,320 PSI for mild steel webs (see page E-22). An acceptable total shear stress in mild steel webs is 24,976 PSI (see page E-22). Hence, an allowable local shear stress for the longitudinal reactions is:

$$24,976 - 12,320 = 12,656 \text{ PSI.}$$

If both the flat bar and the collar plates are omitted, the required local girder web thickness is:

$$T_r = \frac{2 \times 90,090\#}{18" \times 12,656 \text{ PSI}} = 0.7909"$$

Since this is obviously unacceptable, collar plates are required, and the required local girder web and collar plate thickness is:

$$T_r = \frac{2 \times 90,090\#}{2 \times 18" \times 12,656 \text{ PSI}} = 0.3955"$$

and the required weld is:

$$D = 0.628 (0.3955") + 0.085" = 0.3334".$$

Since the required weld is still greater than that normally provided (matching periphery weld), the flat bars should also be provided. The equivalent weld size provided by all three welds is approximately:

$$D = \frac{6" \times 0.1875" + 2 \times 18" \times 0.3125"}{2 \times 18"} = 0.3438" > 0.3334".$$

CONNECTION OF DECK LONGITUDINALS TO SUPPORTING STRUCTURE

Secondary load is a hydrostatic head of eight feet:

$$8 \text{ Ft} \times 64 \text{ \#/Ft}^3 \times 3 \text{ Ft} \times 13.125 \text{ Ft} = 20,160\#.$$

Using same procedure as bottom longitudinals, required local girder web thickness is:

$$T_r = \frac{20,160 \#}{12" \times 12,656 \text{ PSI}} = 0.1327",$$

and required weld is:

$$D = 0.628 (0.1327") + 0.085" = 0.1683" < 0.2812".$$

The provided weld is adequate without collars or flat bars for this local load. However, it should be rechecked when other local loads (such as those from deck mounted foundations) are present.

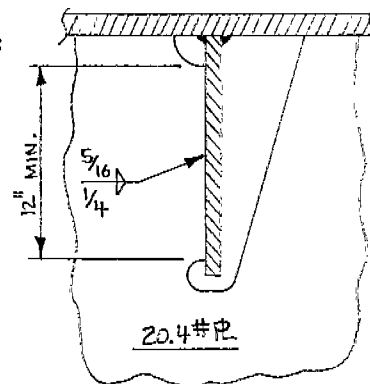

SECTION LKG. FWD



APPENDIX F

CALCULATIONS FOR VANGUARD CLASS CONTAINERSHIP

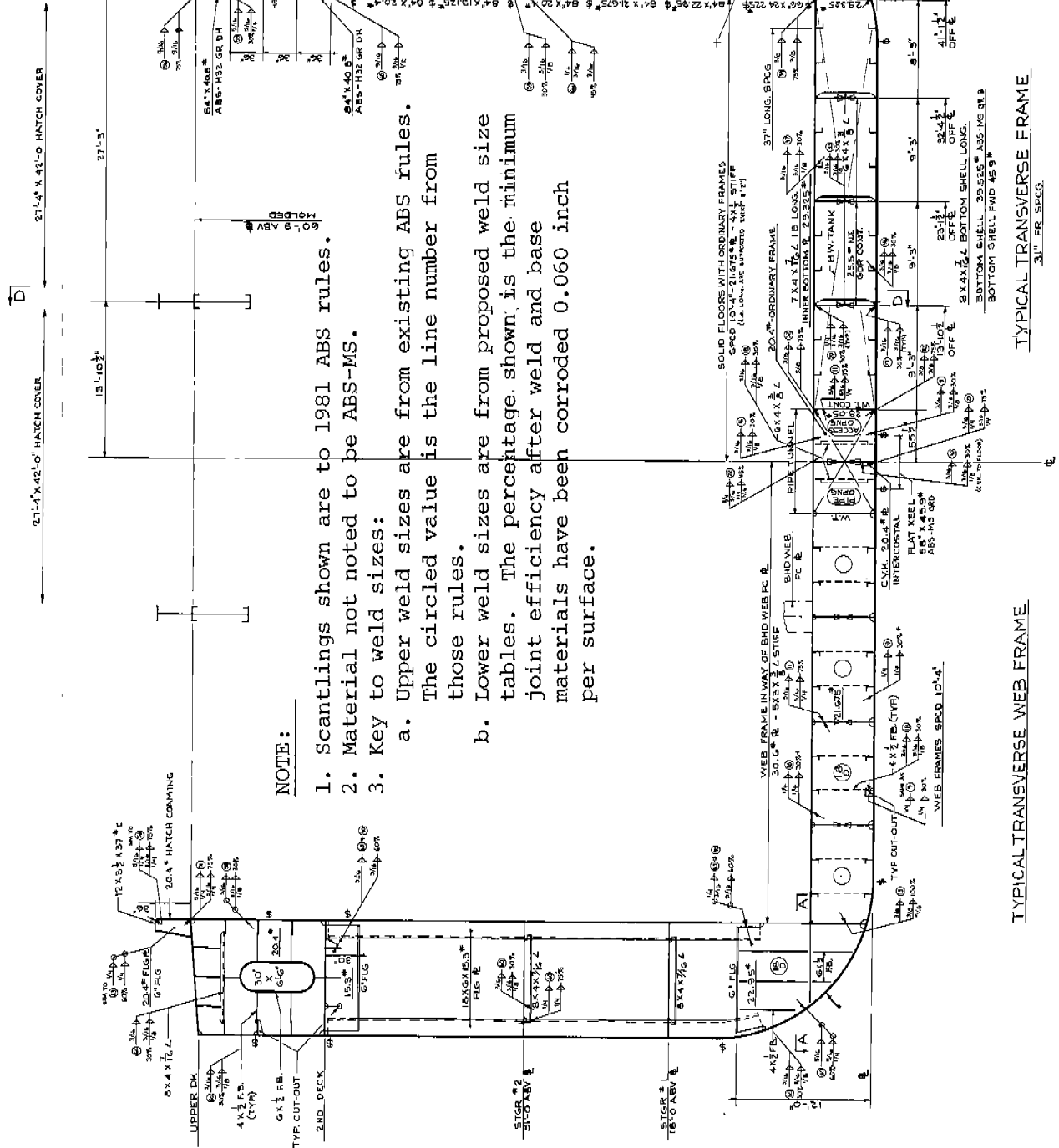

21'-4" X 42'-0" HATCH COVER

D

27'-1" X 42'-0" HATCH COVER

NOTE:

1. Scantlings shown are to 1981 ABS rules.
2. Material not noted to be ABS-MS.
3. Key to weld sizes:
 - a. Upper weld sizes are from existing ABS rules. The circled value is the line number from those rules.
 - b. Lower weld sizes are from proposed weld size tables. The percentage shown is the minimum joint efficiency after weld and base materials have been corroded 0.060 inch per surface.

TYPICAL TRANSVERSE WEB FRAME

TYPICAL TRANSVERSE FRAME

FIGURE F-2

MIDSHIP SECTION OF VANGUARD CLASS CONTAINERSHIP

486-330 - (179)



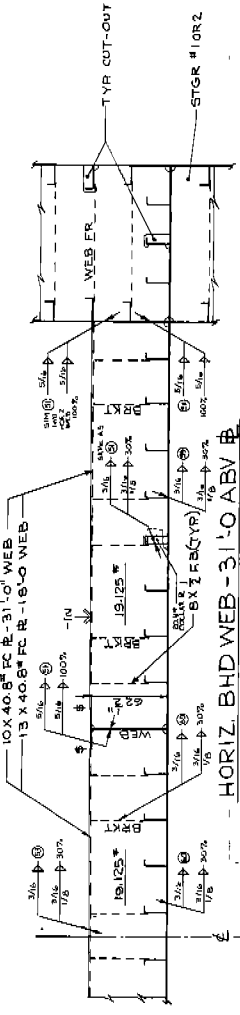

HORIZ. BHD WEB - 31.0' ABV Φ
18'-0" WEB SIMILAR

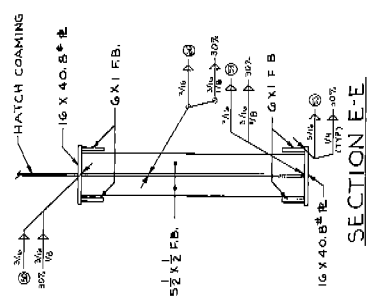
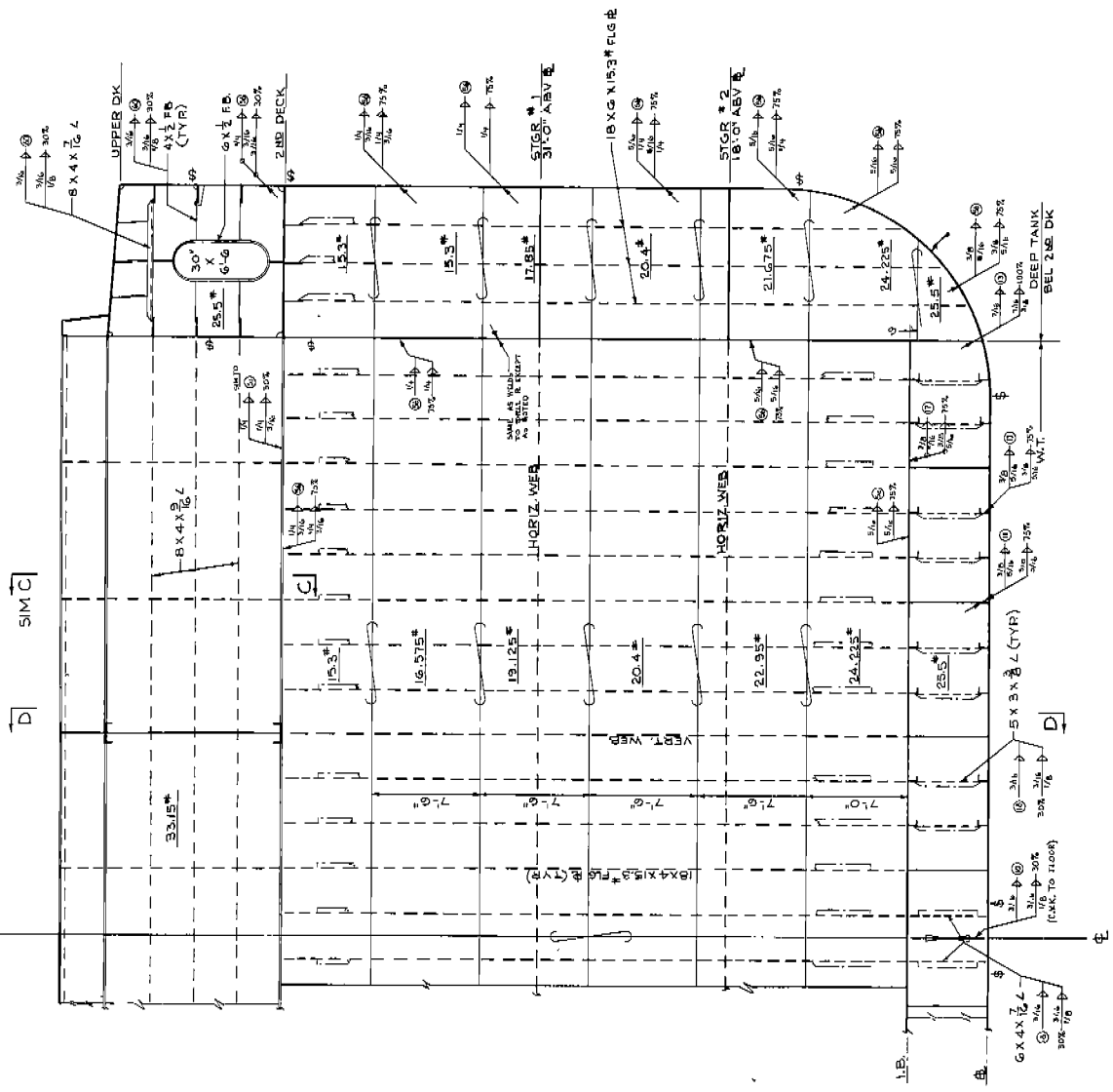

SECTION E-E

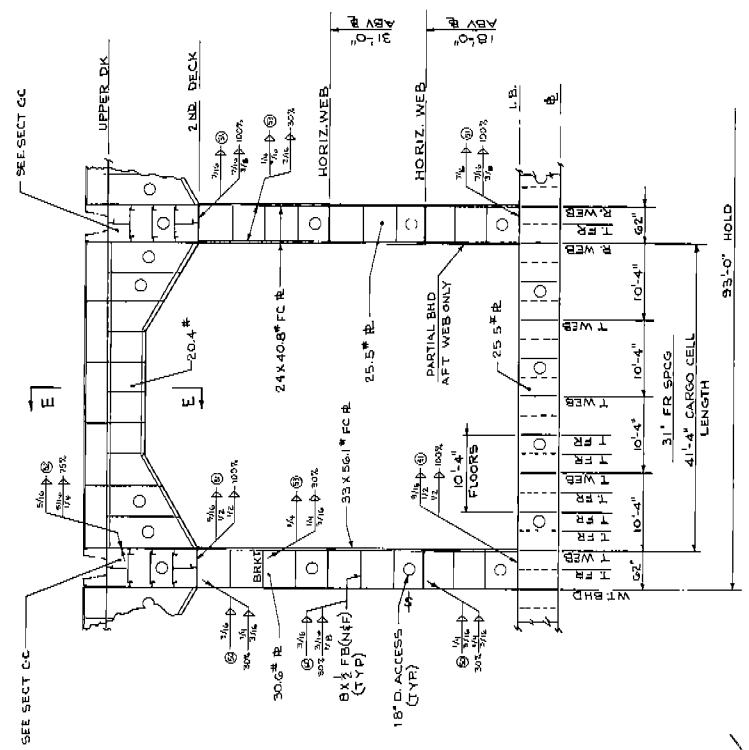

SECTION D-D
13'-10 1/2" OFF Φ

FIGURE F-4

TYPICAL TRANSVERSE BULKHEAD AND GIRDERS OF VANGUARD CLASS CONTAINERSHIP

TABLE F-1

LENGTHS AND WEIGHTS OF ALTERED WELDS FOR VANGUARD CLASS CONTAINERSHIP

STRUCTURAL CONNECTION	Length (Feet)	Number	Total Length of Double Fillet Welds (Feet)	Design Weld Size (Inches)		Weight of Design Welds (Pounds)	
				Existing	Proposed	Existing	Proposed
Long'ls, to Dk, Long'l Bhd, & Shell	470.17	18	8,463	5/16	$\frac{5/16}{1/4}$	2,810	2,304
Long'ls to 2nd Dk	470.17	6	2,821	5/16	1/4	937	599
2nd Dk to Long'l Bhd & Shell	470.17	4	1,881	9/16	$\frac{9/16}{1/2}$	2,024	1,811
Strgr. No. 1 & 2 to Bhd & Shell	470.17	8	3,761	$\frac{1/4}{3/16}$	3/16	624	450
Long'ls to I.B. & Bottom Shell	470.17	32	15,045	3/16	$\frac{3/16}{1/8}$	1,798	1,299
Side Girders to Innerbottom	470.17	6	2,821	$\frac{1/4}{3/16}$	3/16	468	337
Long'l Hatch Gird Web to Dk	449.50	2	899	3/16	$\frac{3/16}{1/8}$	107	78
Long'l Hatch Gird Web to Flg	484.37	2	969	3/16	$\frac{3/16}{1/8}$	116	84
Long'l Hatch Gird Fc Pl to Dk	41.33	38	1,570	5/16	1/4	521	334
Long'l Hatch Gird Fc Pl to Flg	45.0	38	1,710	5/16	1/4	568	363
Long'l Hatch Gird to Box Gird	14.67	86	1,262	5/16	$\frac{5/16}{1/4}$	419	344
Long'l Hatch Gird Web Stiff	7.58	342	2,592	3/16	$\frac{3/16}{1/8}$	310	224
Stiff on Diaph	17.0	24	408	3/16	$\frac{3/16}{1/8}$	49	35
SUBTOTAL-Long'l Str of Cargo Sect	-	-	44,202	0.267 Avg	0.234 Avg	10,751	8,262
Transv Fr to Shell (132 Fr)	44.0	264	11,616	3/16	$\frac{3/16}{1/8}$	1,388	1,003
Transv Fr to Bhd	43.25	264	11,418	3/16	$\frac{3/16}{1/8}$	1,365	986
Stiff to Strgr No. 1 & 2	7.5	528	3,960	3/16	$\frac{3/16}{1/8}$	473	342
Strgr Stiff End Conn	0.583	1,056	616	1/4	$\frac{1/4}{3/16}$	131	102
Stiff on Bilge Brackets	8.5	264	2,244	3/16	$\frac{3/16}{1/8}$	268	194
Stiff on D.B. Side Gird (92 Fr)	5.25	552	2,898	3/16	$\frac{3/16}{1/8}$	346	250
Docking Floor to Side Gird	5.0	184	920	5/16	$\frac{5/16}{1/4}$	305	250
Docking Floor to I.B., Shell & CVK	14.5	184	2,668	3/16	$\frac{3/16}{1/8}$	319	230
Stiff on Docking Floor	5.25	184	966	3/16	$\frac{3/16}{1/8}$	115	83
Solid Floor to Long'l Bhd (40 Fr)	4.25	80	340	3/8	$\frac{3/8}{5/16}$	163	138
Solid Floor to Side Gird	4.75	640	3,040	5/16	$\frac{5/16}{1/4}$	1,009	828
CVK to Solid Floor	4.75	80	380	3/16	$\frac{3/16}{1/8}$	45	33
Stiff on Solid Floor & Long	5.25	720	3,780	3/16	$\frac{3/16}{1/8}$	452	326
SUBTOTAL-132 Transv Fr-40 With Solid Floors	-	-	44,846	0.205 Avg	0.177 Avg	6,379	4,765

TABLE F-1 (Cont'd)

STRUCTURAL CONNECTION	Length (Feet)	Number	Total Length of Double Fillet Welds (Feet)	Design Weld Size (Inches)		Weight of Design Welds (Pounds)	
				Existing	Proposed	Existing	Proposed
Web IWO Box Girder Inc. A.O.	52.25	74	3,866	3/16	$\frac{3/16}{1/8}$	462	334
Stiff on Web IWO Box Girder	23.25	74	1,721	3/16	$\frac{3/16}{1/8}$	206	149
Transv Fr to Shell & Long Bhd	38.75	148	5,735	3/16	$\frac{3/16}{1/8}$	686	495
Stiff to Strgr No. 1 & 2	7.0	148	1,036	3/16	$\frac{3/16}{1/8}$	124	89
Bilge Brkt to Shell & Bhd	21.75	74	1,610	5/16	$\frac{5/16}{1/4}$	535	438
Stiff on Bilge Brkt	22.0	74	1,628	3/16	$\frac{3/16}{1/8}$	195	141
Frame to Bilge Brkt	3.25	148	481	$\frac{1/4}{3/16}$	3/16	80	57
Brkts IWO 1.B.	8.5	148	1,258	5/16	$\frac{5/16}{1/4}$	418	343
Floor to Long Bhd	4.25	74	315	3/8	$\frac{3/8}{5/16}$	151	128
Floor to Side Girders	4.75	592	2,812	5/16	$\frac{5/16}{1/4}$	934	766
C.V.K. to Floor	4.75	74	352	3/16	$\frac{3/16}{1/8}$	42	30
Stiff to Floor & Long's	5.25	666	3,496	3/16	$\frac{3/16}{1/8}$	418	302
SUBTOTAL-37 Transv Web Fr	-	-	24,310	0.227 Avg.	0.199 Avg.	4,251	3,272

TABLE F-1 (Cont'd)

STRUCTURAL CONNECTION	Length (Feet)	Number	Total Length of Double Fillet Welds (Feet)	Design Weld Size (Inches)		Weight of Design Welds (Pounds)	
				Existing	Proposed	Existing	Proposed
Deck Transv to Deck	82.0	10	820	1/4	$\frac{1/4}{3/16}$	174	136
Deck Transv to FC P _L	82.0	10	820	1/4	$\frac{1/4}{3/16}$	174	136
Deck Transv to Long'l Box G. P _L	12.0	20	240	$\frac{1/2}{7/16}$	7/16	180	156
Web IWO Box Girder Inc. A.O.	52.25	20	1,045	$\frac{1/4}{3/16}$	3/16	173	125
Stiff on Web IWO Box Gird	23.25	20	465	3/16	$\frac{3/16}{1/8}$	56	40
Side Transv to Shell & Long'l Bhd	100.5	20	2,010	3/16	$\frac{3/16}{1/8}$	240	174
Side Transv to 2nd Deck	7.25	20	145	5/16	$\frac{5/16}{1/4}$	48	39
Side Transv Stiffeners	44.0	60	2,640	3/16	$\frac{3/16}{1/8}$	316	228
Brkts (Dk Transv-Side Transv)	16.0	20	320	5/16	$\frac{5/16}{1/4}$	106	87
Brkt FC P _L 's (Dk Transv-Side Transv)	12.0	20	240	3/16	$\frac{3/16}{1/8}$	29	21
Brkts & FC P _L 's (I.B.-Side Transv)	28.0	10	280	3/16	$\frac{3/16}{1/8}$	33	24
Brkt Stiffeners	21.0	30	630	3/16	$\frac{3/16}{1/8}$	75	54
Floor to Shell, IB & Long	38.88	40	1,555	$\frac{3/8}{5/16}$	5/16	630	516
Floor to Long Bhd	4.25	20	85	$\frac{9/16}{1/2}$	1/2	82	72
Floor to Side Girders	4.75	160	760	$\frac{3/8}{5/16}$	$\frac{7/16}{3/8}$ (2)	308	429
C.V.K. to Floor	4.75	20	95	3/16	$\frac{3/16}{1/8}$	11	8
Stiff to Floor & Long'l's	5.25	180	945	3/16	$\frac{3/16}{1/8}$	113	82
FC P _L to Horiz Web	78	20	1,560	3/16	$\frac{3/16}{1/8}$	186	135
Horiz Web Stiffeners	5.0	150	750	3/16	$\frac{3/16}{1/8}$	90	65
Horiz Web to Vert Web & Long'l Bhd	5.0	60	300	3/8	$\frac{3/8}{5/16}$	143	122
Vert Web to FC P _L 's & Part Bhd	43.0	20	860	$\frac{1/4}{3/16}$	3/16	143	103
Vert Web to 2nd Dk & I.B.	5.0	20	100	7/16	$\frac{7/16}{3/8}$	65	56
Diaph to Dk & Transv Box G	27.5	30	825	3/16	$\frac{3/16}{1/8}$	99	71
Diaph Stiffeners	17.0	30	510	3/16	$\frac{3/16}{1/8}$	61	44
Vert Web Stiffeners	6.33	140	886	3/16	$\frac{3/16}{1/8}$	106	76
Partial Bhd Periphery	89.5	5	448	3/16	$\frac{3/16}{1/8}$	54	39
Partial Bhd Stiffeners	11.5	120	1,380	3/16	$\frac{3/16}{1/8}$	165	119
SUBTOTAL-10 Ring Webs	-	-	20,714	0.234 Avg	0.212 Avg	3,860	3,157

486-330

F184

95%

TABLE F-1 (Cont'd)

STRUCTURAL CONNECTION	Length (Feet)	Number	Total Length of Double Fillet Welds (Feet)	Design Weld Size (Inches)		Weight of Design Welds (Pounds)	
				Existing	Proposed	Existing	Proposed
Deck Transv to Deck	82.0	14	1,148	1/4	<u>3/16</u>	244	191
Deck Transv to FC P _L	82.0	14	1,148	1/4	<u>3/16</u>	244	191
Deck Transv to Long Bhd	12.0	28	336	<u>7/16</u>	7/16	252	218
Web IWO Box Girder Inc. A.O.	52.25	14	732	<u>3/16</u>	3/16	122	87
Stiff on Web IWO Box Gird	23.25	14	326	3/16	<u>1/8</u>	39	28
Bhd Stiff to P _L	43.25	210	9,082	3/16	<u>3/16</u>	1,086	784
Stiff to Floor & Long'ts	5.25	126	662	3/16	<u>1/8</u>	79	57
C.V.K. to Floor	4.75	14	66	3/16	<u>1/8</u>	8	6
Floor to Long. Bhd	5.0	14	70	7/16	<u>3/8</u>	46	40
Horiz Web to Bhd	64.0	14	896	3/16	<u>3/16</u>	107	77
Face Plate to Horiz Web	82.0	14	1,148	3/16	<u>1/8</u>	137	99
Stiff on Horiz Web	4.0	252	1,008	3/16	<u>1/8</u>	120	87
Horiz Web & Collar P _L to Bhd Stiff	2.0	336	672	3/16	<u>1/8</u>	80	58
Vert Web to Bhd	28.5	14	399	3/16	<u>1/4</u> <u>3/16</u> (2)	48	66
Vert Web to FC P _L	43.0	14	602	1/4	<u>3/16</u>	128	100
Vert Web to 2nd Dk & I.B.	5.0	28	140	<u>9/16</u> <u>1/2</u>	1/2	135	119
Vert Web Stiff	6.33	196	1,241	3/16	<u>1/8</u>	148	107
Diaph to Dk & Transv Box Girder	27.5	42	1,155	3/16	<u>3/16</u>	138	100
Diaph Stiffeners	17.0	42	714	3/16	<u>1/8</u>	85	62
Bhd Periphery	7.5	28	210	5/16	<u>1/4</u>	70	57
SUBTOTAL-7 Bhds	-	-	21,755	0.212 Avg.	0.185 Avg.	3,316	2,534
SUBTOTAL-All Cargo Sect. Structure	-	-	155,827	0.232 Avg.	0.204 Avg.	28,557	21,990
ESTIMATE FOR BOW, STERN, MACHINERY SPACE & DECKHOUSE(1)	-	-	35,840	0.232 Avg.	0.204 Avg.	6,559	5,071
TOTAL	-	-	191,667	0.232 Avg.	0.204 Avg.	35,116	27,061

NOTES:

(1) The 470.17 foot long cargo section is assumed to be essentially prismatic. Therefore, the length and weight estimates for the cargo section should be slightly high. This is compensated for by deliberately underestimating weld lengths and weights for the bow, stern, machinery space, and deckhouse.

(2) Proposed weld sizes which are increased from existing values are highlighted by reference to this note.

486-330

185

9570

TABLE F-2

LENGTHS AND WEIGHTS OF UNALTERED WELDS FOR VANGUARD CLASS CONTAINERSHIP

STRUCTURAL CONNECTION	Length (Feet)	Number	Total Length of Double Fillet Welds (Feet)	Design Weld Size (Inches)	Weight of Design Welds (Pounds)
Inbd. Hatch Coaming to Dk & to Face Plate	392.67	4	1571	$\frac{5/16}{1/4}$	428
Outbd Hatch Coaming to Dk & to Channel	413.33	4	1653	$\frac{5/16}{1/4}$	450
Long. Bhd. to Deck	470.17	2	940	9/16	1011
Inner Bottom to Long'l. Bhd.	470.17	2	940	3/8	449
Long. Bhd. to Shell	470.17	2	940	3/8	449
N.T. Girders to Shell	470.17	6	2821	3/16	337
W.T. Girders to Shell & I.B.	470.17	4	1881	3/8	899
C.V.K. to I.B.	470.17	1	470	$\frac{1/4}{3/16}$	78
C.V.K. to Shell	470.17	1	470	$\frac{5/16}{1/4}$	128
SUBTOTAL-LONG'L. STR. OF CARGO SEC	-	-	11,686	0.326 Avg.	4,229
Transv. Frame End Conn.	1.833	1056	1936	3/16	231
Clips at 2nd Dk.	2.833	528	1496	1/4	318
Bilge Brackets	12.25	264	3234	1/4	687
Solid Floors to Shell, I.B. & Long.	38.88	160	6221	1/4	1322
SUBTOTAL-132 TRANSV. FR-40 WITH SOLID FLOORS	-	-	12,887	0.242 Avg.	2,558
Hatch Coaming Brackets	5.25	74	388	1/4	82
Header Below 2nd Dk.	18.33	74	1356	3/16	162
Strgr. No. 1 & 2 Stiff. End Conn.	0.833	296	247	1/4	52
Floor to Shell, I.B., & Long.	38.88	148	5754	1/4	1223
SUBTOTAL-37 TRANSV. WEB FR.	-	-	7,745	0.240 Avg.	1,519
Hatch Coaming to Dk. & to Channel	82.0	20	1640	$\frac{5/16}{1/4}$	447
Hatch Coaming Brackets	5.25	100	525	1/4	112
Stiff. on Transv. Box Girder	82.0	30	2460	3/16	294
Strgr. No. 1 & 2 to Transv. Web	18.75	40	750	5/16	249
SUBTOTAL-10 RING WEBS	-	-	5,375	0.246 Avg.	1,102

TABLE F-2 (Cont'd)

STRUCTURAL CONNECTION	Length (Feet)	Number	Total Length of Double Fillet Welds (Feet)	Design Weld Size (Inches)	Weight of Design Welds (Pounds)
Hatch Coaming to Dk. & to Channel	82.0	20	1640	$\frac{5}{16}$ $\frac{1}{4}$	447
Hatch Coaming Brackets	5.25	100	525	1/4	112
Stiff. on Transv. Box Girder	82.0	42	3444	3/16	412
Bhd. Periphery Inc. Collar Plates	163.5	7	1144	$\frac{1}{4}$ $\frac{3}{16}$	190
Bhd. Periphery	60	7	420	1/4	89
Bhd. Periphery	45	7	315	$\frac{5}{16}$ $\frac{1}{4}$	86
Bhd. Periphery	142.25	7	996	5/16	331
Bhd. Periphery Inc. Collar Plates	387	7	2709	$\frac{3}{8}$ $\frac{5}{16}$	1097
Horiz. Web to Vert. Webs & Long. Bhd.	5.0	84	420	5/16	139
Collar Pl. to Horiz. Webs	1.25	336	420	1/4	89
Strgr. No. 1 & 2 to Transv. Web	18.75	28	525	5/16	174
Vert. Web to Bhd.	14.5	14	203	$\frac{1}{4}$ $\frac{3}{16}$	34
SUBTOTAL - 7 BHDS.	-	-	12,761	0.272 Avg.	3,200
SUBTOTAL-ALL CARGO SECTION STRUCT.	-	-	50,454	0.271 Avg.	12,608
ESTIMATE FOR BOW, STERN, MACHY, SPACE, AND DECKHOUSE	-	-	11,604	0.271 Avg.	2,898
TOTAL	-	-	62,058	0.271 Avg.	15,506

486-330 - (187)

95%

MIDSHIP SECTION - 1981 ABS RULES

(Terms are as defined in ABS Rules unless noted otherwise)

Principal Dimensions

LOA 725'-0"
 B 103'-0"
 D 60'-0"
 Values at scantling draft:
 d 34'-0"
 LWL 702'-0"
 LBP 687'-6"

Weights (Long Tons)

Light Ship		12,500
Fuel Oil	3,300	
D.O. & L.O.	30	
Fresh water	300	
Crew & Stores	50	
Cargo	19,740	
Clean Ballast	2,580	
<u>TOTAL DEADWEIGHT</u>		<u>26,000</u>
DISPLACEMENT		38,500
(at scantling draft)		

REQUIRED SECTION MODULUS - MILD STEEL

Section 2.1 Scantling length = L = 0.97 x LWL = 680.94'

Section 6.3.1(a) SM = M_t / f_p
 $f_p = 10.56 - \frac{790-L}{845} = 10.431 \text{ LT/in}^2$

Section 6.3.1(b) $C_1 = 0.01441 \left[10.75 - \left(\frac{984-L}{328} \right)^{1.5} \right] = 0.14211$

$C_b = \frac{\text{Displacement} \times 35 \text{ ft}^3/\text{LT}}{L \times B \times d} = 0.56507$ (use minimum value of 0.60 for this section)

Min. SM = $0.01C_1 L^2 B (C_b + 0.70) = 88,231 \text{ in}^2 \text{ ft}$

Section 6.3.2 (a) $C_{st} = \left[0.275 + \frac{690-L}{16,400} \right] 10^{-3} = 0.27555 \times 10^{-3}$

$C_b = 0.64$ (minimum value for this section)

$M_{sw} = C_{st} L^{2.5} B (C_b + 0.5) = 391,485 \text{ Ft-LT}$

Section 6.3.2(b) $C_b = 0.64$ (minimum value for this section)

$K_b = 1.4 - 0.5 C_b = 1.08$

$C_2 = \left[6.53C_b + 0.57 \right] 10^{-4} = 4.7492 \times 10^{-4}$

APP

$$H_e = 0.0181 L + 11.535 = 23.860 \text{ Ft}$$

$$M_w = C_2 L^2 B H_e K_p = 584,480 \text{ Ft-LT}$$

$$M_t = M_{sw} + M_w = 975,965 \text{ Ft-LT}$$

$$SM = M_t/f_p = 93,564 \text{ in}^2 \text{ Ft} \text{ (96 and 93\% of 1970 ABS Rules Deck and Baseline values)}$$

REQUIRED MOMENT OF INERTIA AND SECTION MODULUS - H32 STEEL

Section 6.13.2 $I_{H32} = L \times SM/34.1 = 1,868,372 \text{ in}^2 \text{ Ft}^2$

Section 6.13.3 $Q = 0.78050$ (see page E-11)

$$SM_{H32} = Q(SM) = 73,027 \text{ in}^2 \text{ Ft}$$

SCANTLINGS

Use H32 material in deck.

Reduce main deck and shear strake from 56.1# to 45.9# \underline{R}

Reduce longitudinal bulkhead from 56.1# to 40.8#

Reduce main deck longitudinals from 51.0# to 40.8#

Resulting properties:

$$I = 2,774,384 \text{ in}^2 \text{ ft}^2 > 1,868,372 \text{ in}^2 \text{ ft}^2$$

$$SM_{dk} = 74,890 \text{ in}^2 \text{ ft} > 73,027 \text{ in}^2 \text{ ft}$$

$$SM_{\underline{R}} = 120,867 \text{ in}^2 \text{ ft} > 93,564 \text{ in}^2 \text{ ft}$$

Neutral axis is 22.954 Ft above \underline{R}

MAXIMUM HULL GIRDER SHEARING FORCE

Section 6.3.3(a) $V_p = F_{sw} + F_w$

Section 6.3.3(b) $V_p = 5.0 M_{sw/L} + 2.6 M_w/L = 5106.3 \text{ LT}$

SIMPLIFIED STRESS ANALYSIS FOR BOTTOM LONGITUDINALS

Bottom longitudinals are rolled 8" x 4" x 7/16" mild steel angles with 37" spacing on 39.525# mild steel bottom plate and spans of 5'-2".

Section 3.9 Effective plate width = $(5.167' \times 12"/') / 3 = 20.667"$

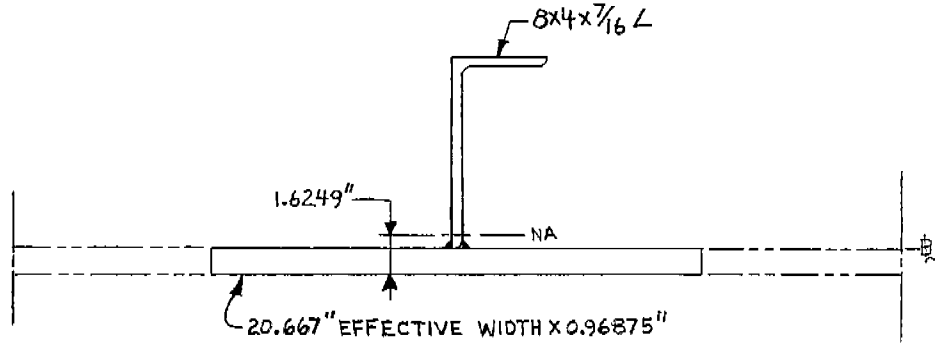

Section 7.3.8 $c = 1.30$
 $h = 2/3 \times 60 \text{ Ft} = 40 \text{ Ft}$
 $L = \text{Span} = 6 \text{ Ft minimum}$
 $s = \text{Spacing} = 3.083 \text{ Ft}$

Design Load on Longitudinal =

$$64\#/Ft^3 \times 40 \text{ Ft} \times 6 \text{ Ft} \times 3.083 \text{ Ft} = 47,355\#$$

Actual Load on Longitudinal =

$$64\#/Ft^3 \times 40 \text{ Ft} \left[5.167 \text{ Ft} \times 3.083 \text{ Ft} - \frac{4}{2} \left(\frac{3.083 \text{ Ft}}{2} \right)^2 \right] = 28,614\#$$

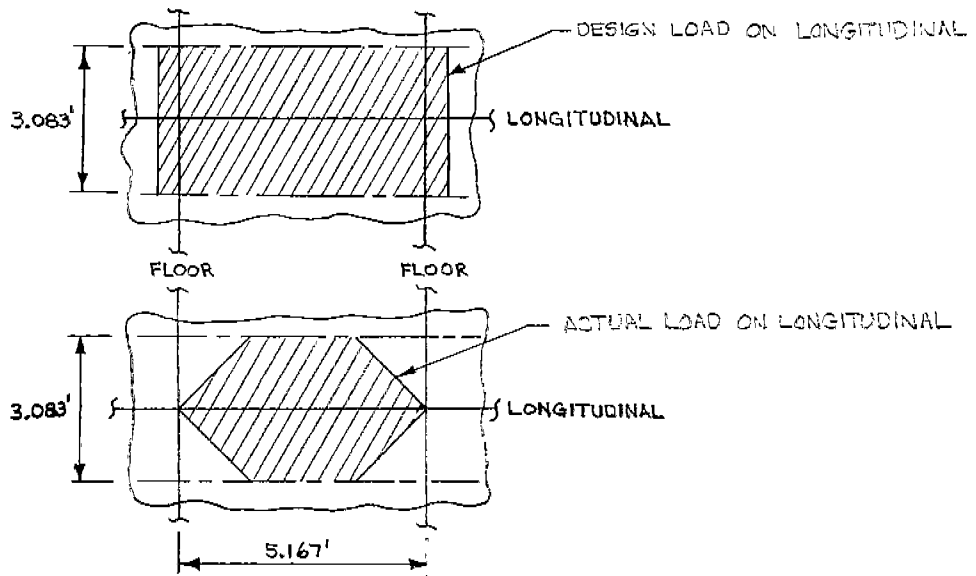

Design stresses for containership mild steel bottom structure

Section 6.3.1(a) $\sigma_p = 10.431 \text{ Lt/in}^2 = 23,365 \text{ PSI}$

Section 7.3.3 and
Page E-23 $\sigma_s = \frac{15,610}{1.30} = 12,008 \text{ PSI}$

$\sigma_T = 35,373 \text{ PSI}$

Section 6.3.3 $\tau_p = 6.75 \text{ Lt/in}^2 = 15,120 \text{ PSI}$

Use 60% of σ_s $\tau_s = 0.6 (12,008) = 7,205 \text{ PSI}$

$\tau_T = 22,325 \text{ PSI}$

Primary Strength Values, $V_p = 5106.3 \text{ LT} = 11,438,112\#$
 $(AY)_p = 9.497 \text{ in. Ft}^2$
 $I_p = 2,774,384 \text{ in}^2 \text{ Ft}^2$

Secondary Strength Values, Design $V_s = 23,677\#$
 Actual $V_s = 14,307\#$
 $(AY)_s = 22.834 \text{ in}^2$
 $I_s = 164.87 \text{ in}^4$

$$\tau_r = \frac{1}{\tau_T} \left[\frac{V_p (AY)_p}{I_p} + \frac{V_s (AY)_s}{I_s} \right]$$

$D = 0.628 (\tau_r) + 0.085"$ for mild steel.

For design load, $\tau_r = \frac{1}{22,325 \text{ \#/in}^2} [39.2 \text{ \#/in.} + 3279.2 \text{ \#/in.}] = 0.14864 \text{ in.}$

$D = 0.628 (0.14864") + 0.085" = 0.1783" > 0.1562" \text{ N.G.}$

For actual load, $\tau_r = \frac{1}{22,325 \text{ \#/in}^2} [39.2 \text{ \#/in.} + 1981.5 \text{ \#/in.}] = 0.090513 \text{ in.}$

$D = 0.628 (0.090513") + 0.085" = 0.1418" < 0.1562" \text{ OK}$

NOTE: The difference between the actual and design values primarily accounts for that portion of the load on the bottom shell plating which would be transferred directly into the floors rather than through the longitudinals and then into the floors. This correction is more important to an analysis of shear forces (as required here) than to an analysis of bending moments in the member (as required by normal ABS Rule design procedures) because the load removed is near the ends of the span. The conservative values specified by ABS for an analysis of bending moments also helps to ensure that the longitudinal selected

will have sufficient inertia to prevent premature buckling of the bottom shell. This design requirement does not put a significant load on the weld connection. Hence, there should be no significant problem with using a lower load for the shear stress analysis of the weld connection than that used for a bending stress analysis when sizing the longitudinal.

CONNECTION OF BOTTOM LONGITUDINALS TO SUPPORTING STRUCTURE

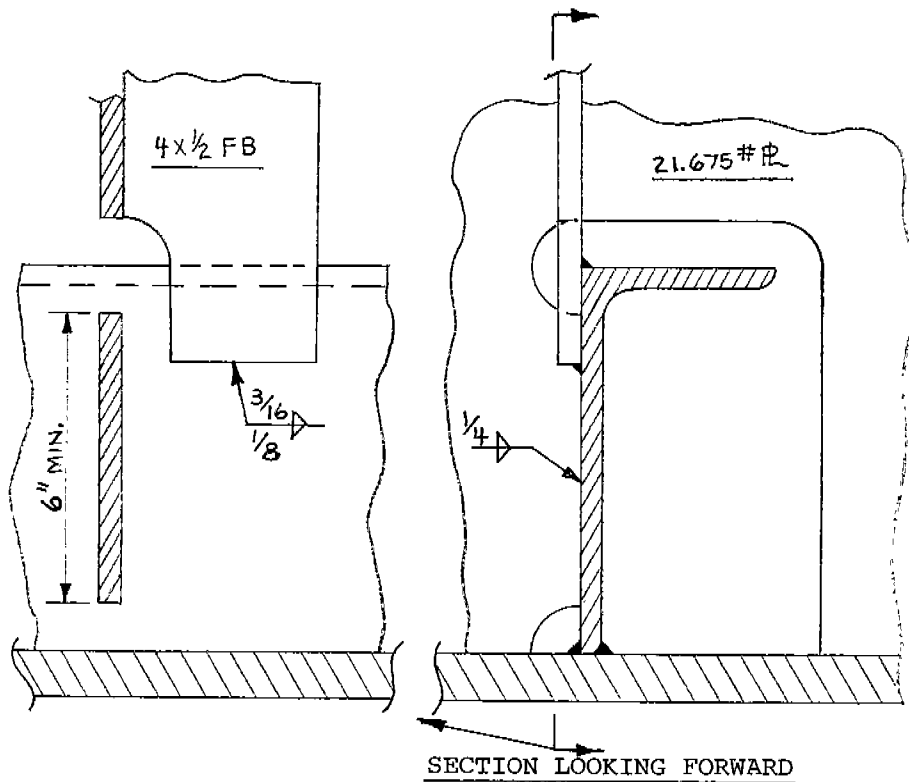

From Section 7.3.8 of ABS rules, design head is $\frac{2}{3} \times 60' = 40'$, and minimum design span is 6'. Actual span is 5.17' and spacing is 3.083'. Total design load on connection is:

$$40 \text{ Ft} \times 64 \text{ \#/Ft}^3 \times 6 \text{ Ft} \times 3.083 \text{ Ft} = 47,355 \text{ \#}.$$

Chapter 7 of the ABS rules does not give allowable stresses for double bottom floors. Therefore, a total allowable shear stress of 24,976 PSI from page E-22 will be used. Based on a grillage analysis of the double bottom structure, the maximum shear stress in the floors is 3698 PSI. Hence, an allowable shear stress for this local connection is: $24,976 - 3698 = 21,278 \text{ PSI}$. The required local floor thickness is then:

$$T_r = \frac{47,355 \text{ \#}}{6" \times 21,278 \text{ PSI}} = 0.3709",$$

and the required weld is:

$$D = 0.628 (0.3709") + 0.085" = 0.3179".$$

The equivalent weld size provided is approximately:

$$D = \frac{6" \times 0.25" + 5" \times 0.15625"}{6"} = 0.3802" > 0.3179" \text{ OK.}$$

In this case, collar plates are not required; the web and flat bar connections are adequate. However, if the flat bars are eliminated for any reason, the weld of the floor to the longitudinals should be increased, collar plates added, or the design load could possibly be reduced as discussed on pages F-14 and F-15.

DOUBLE-BOTTOM GIRDERS

Design load for bottom structure is head of $2/3 \times 60' = 40'$.

Design pressure =
 $40 \text{ Ft} \times 64 \text{ \#/Ft}^3 = 2560 \text{ \#/Ft}^2$

Total load =
 $2560 \text{ \#/Ft}^2 \times 82.25' \times 41.33' = 8,702,445\#$

Check weight of containers
 $11.86 \text{ LT/CONT.} \times 9 \text{ athw} \times 7 \text{ high} \times 2 \text{ rows} =$
 $1494.36 \text{ LT} = 3,347,366\#$
 Does not govern even if dynamic effects were included.

Grillage will be essentially simply supported along longitudinal edges and fixed along athwartship edges.

Using Schade's grillage analysis (Trans. SNAME 1941)

$a = 82.25'$	$b = 41.33'$
$S_a = 5.167'$	$S_b = 9.25'$
$I_{na} = 127,676 \text{ in}^4$	$I_{nb} = 220,449 \text{ in}^4$
$I_{pa} = 114,454 \text{ in}^4$	$I_{pb} = 204,779 \text{ in}^4$
$i_a = 2059.3 \text{ in}^3$	$i_b = 1986.0 \text{ in}^3$
$A_a = 35.06 \text{ in.}$	$A_b = 41.25 \text{ in}^2$
$r_a = 37.475 \text{ in.}$	$r_b = 37.827 \text{ in.}$

$$\eta = \sqrt{\frac{I_{pa}}{I_{na}} \frac{I_{pb}}{I_{nb}}} = 0.9125 \quad \rho = a/b \sqrt{\frac{i_b}{i_a}} = 1.972$$

From Figure 6, $K = 0.0930$ and $\sigma_x = K \frac{pb^2 r_b}{i_b} = 7746 \text{ PSI}$

From Figure 9, maximum shear stress in short webs, $K = 0.513$ and

$$\tau = K \frac{pb I_{nb}}{A_b i_b} = 12,172 \text{ PSI}$$

From Figure 8, maximum shear stress in long webs, $K = 0.235$ and

$$\tau = K \frac{pb I_{na}}{A_a \sqrt[4]{i_a^3 i_b}} = 3698 \text{ PSI}$$

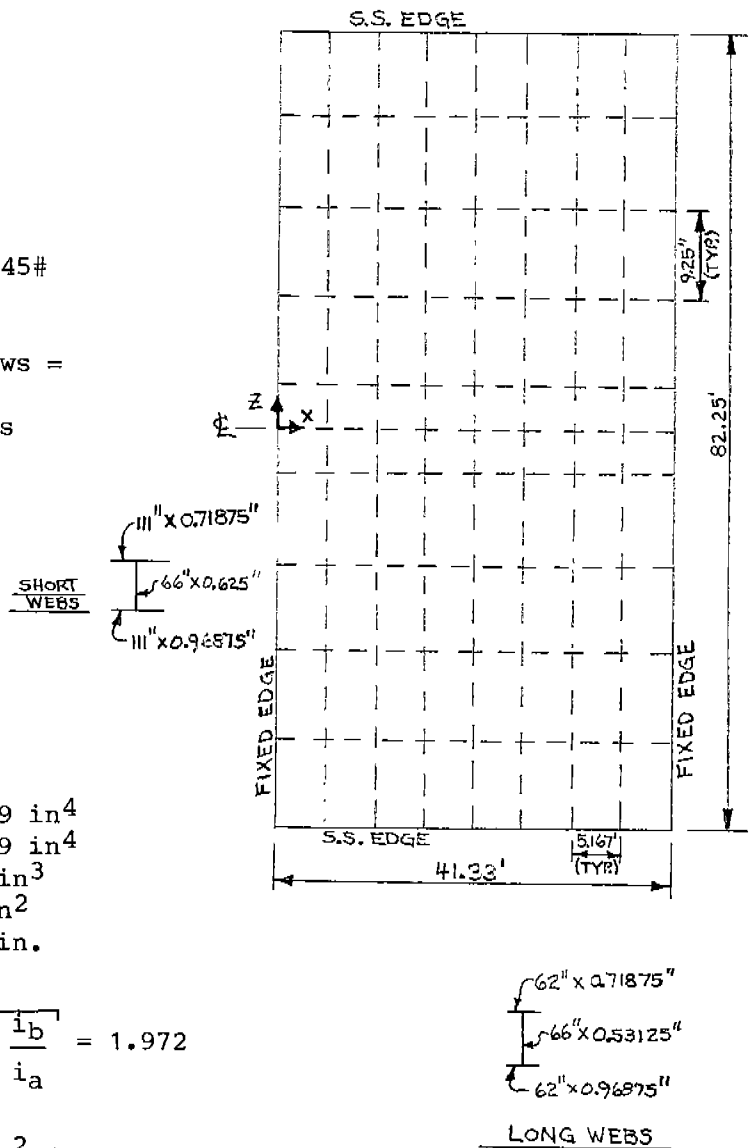

APPENDIX G

CALCULATIONS FOR CRESCENT CLASS ORE/BULK/OIL CARRIER

G-1

486-330 - (197)

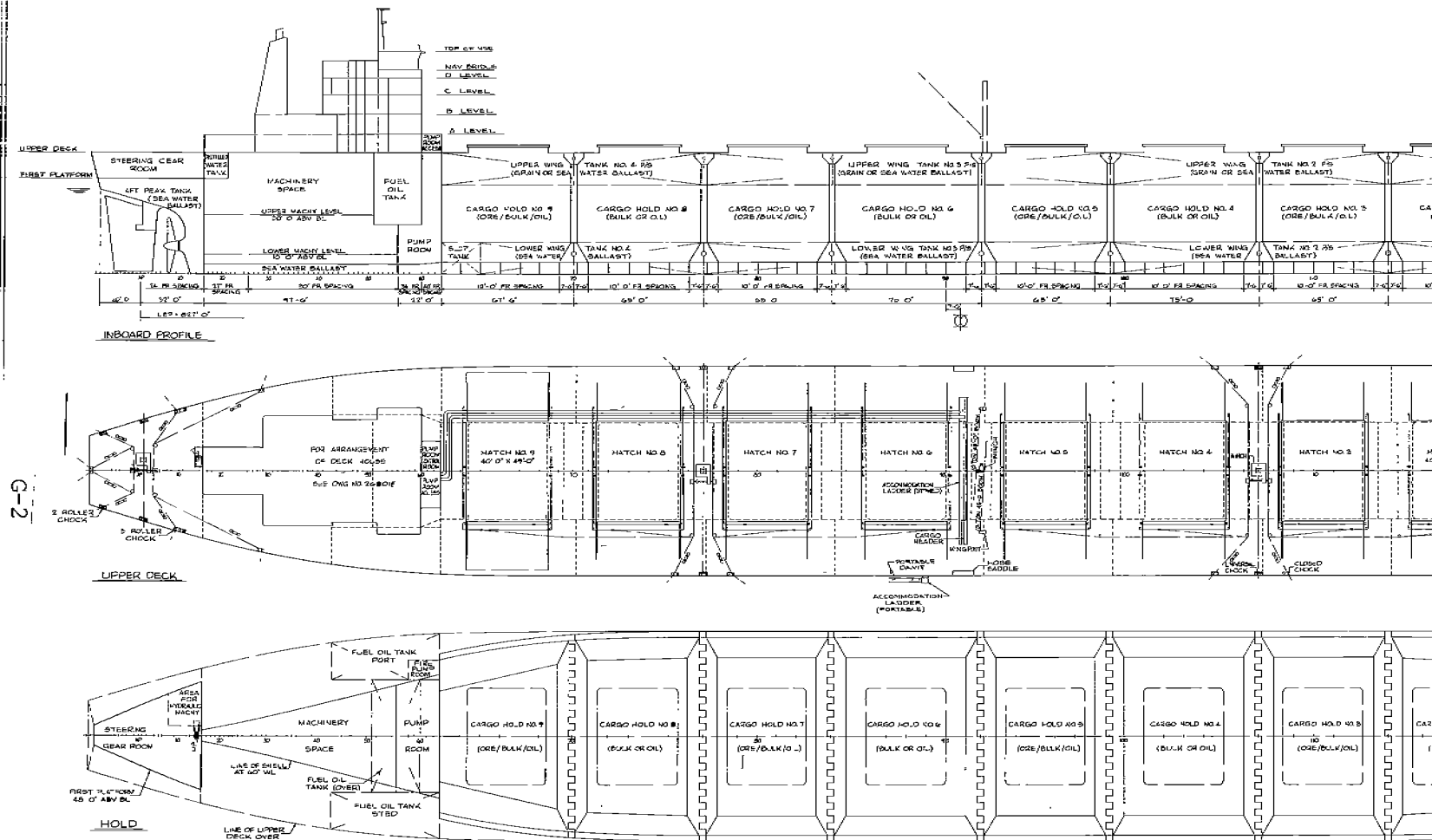

FIGURE G-1

GENERAL ARRANGEMENT DRAWINGS OF CRESCENT CLASS ORE/BULK/OIL CARRIER

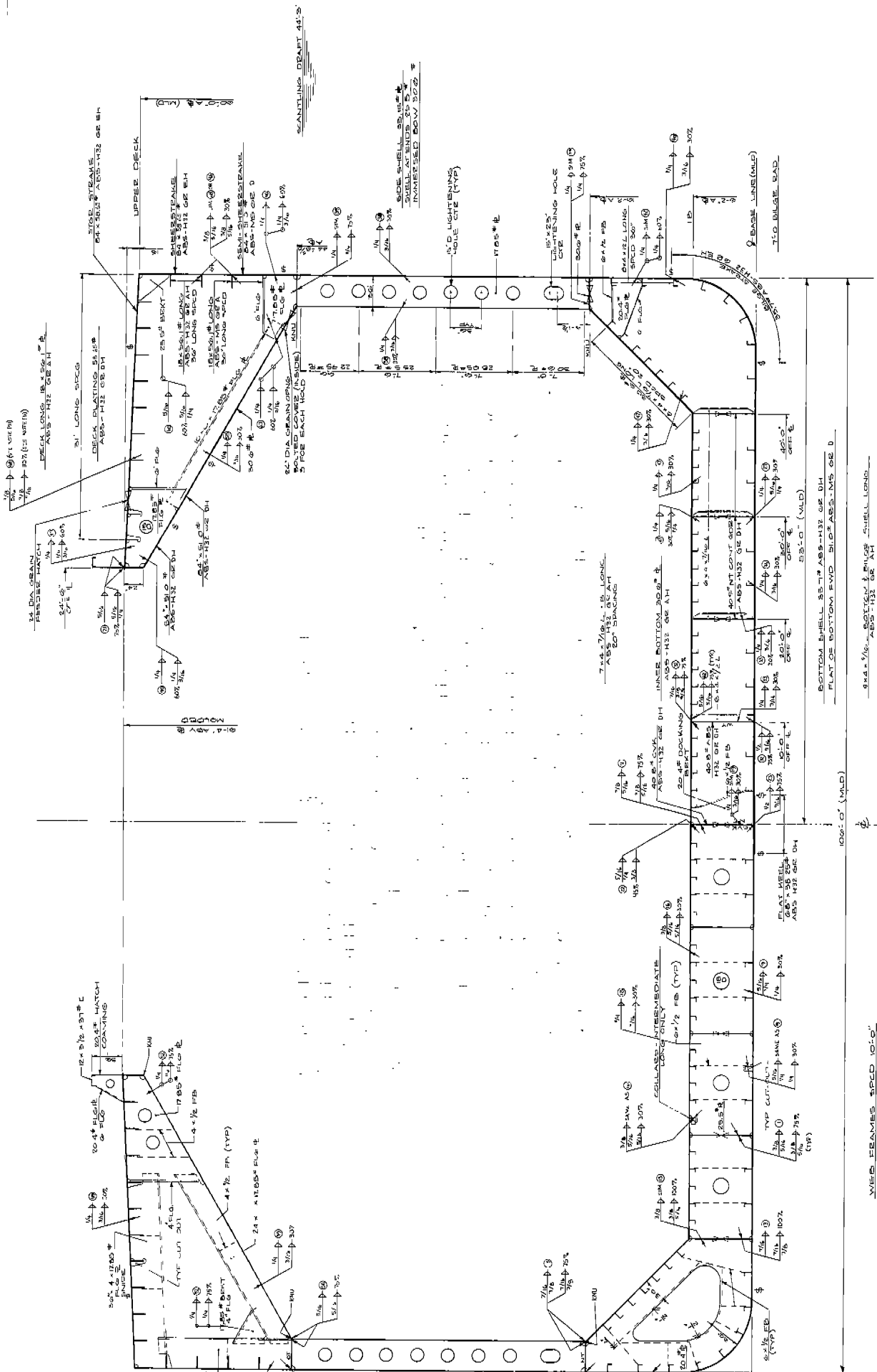

FIGURE G-2
ORDINARY FRAME
TRANSV. RE. L²66 = 40

MIDSHIP SECTION OF CRESCENT CLASS ORE/BULK/OIL CARRIER

NOTE:

1. Scantlings shown are to 1981 ABS rules.
2. Material not noted to be ABS-MS.
3. All scantlings shown apply to .4L midship length except as noted.
4. Key to weld sizes:
 - a. Upper weld sizes are from existing ABS rules.
The circled value is the line number from those rules.
 - b. Lower weld sizes are from proposed weld size tables.
The percentage shown is the minimum joint efficiency after weld and base materials have been corroded 0.060 inch per surface.
5. Weld for 1.375" plating requires ABS approval. Since plating is only 3% thicker than the maximum value for which a weld is specified (1.34") the next larger weld size (11/32 or $\frac{3}{8}$ / $\frac{5}{16}$) is used.
6. Weld determined from 30% efficiency for H32 material:
$$D = 0.3 \times 0.668(T - 0.12) + 0.085" = 0.3365" \text{ or } 11/32 \text{ or } \frac{3}{8}/\frac{5}{16}$$
7. Minimum weld size for oil carriers is used (1/4" for ABS welds and 3/16" for proposed welds).



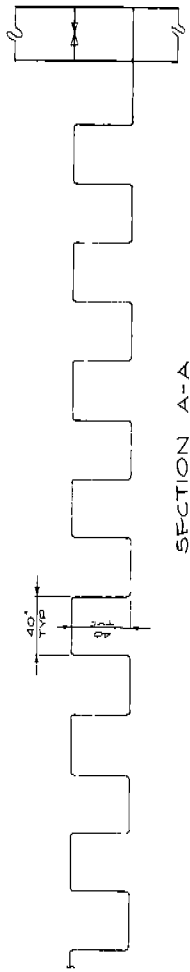

SECTION A-A

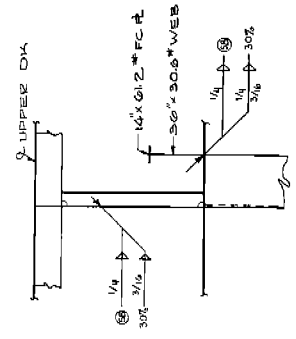
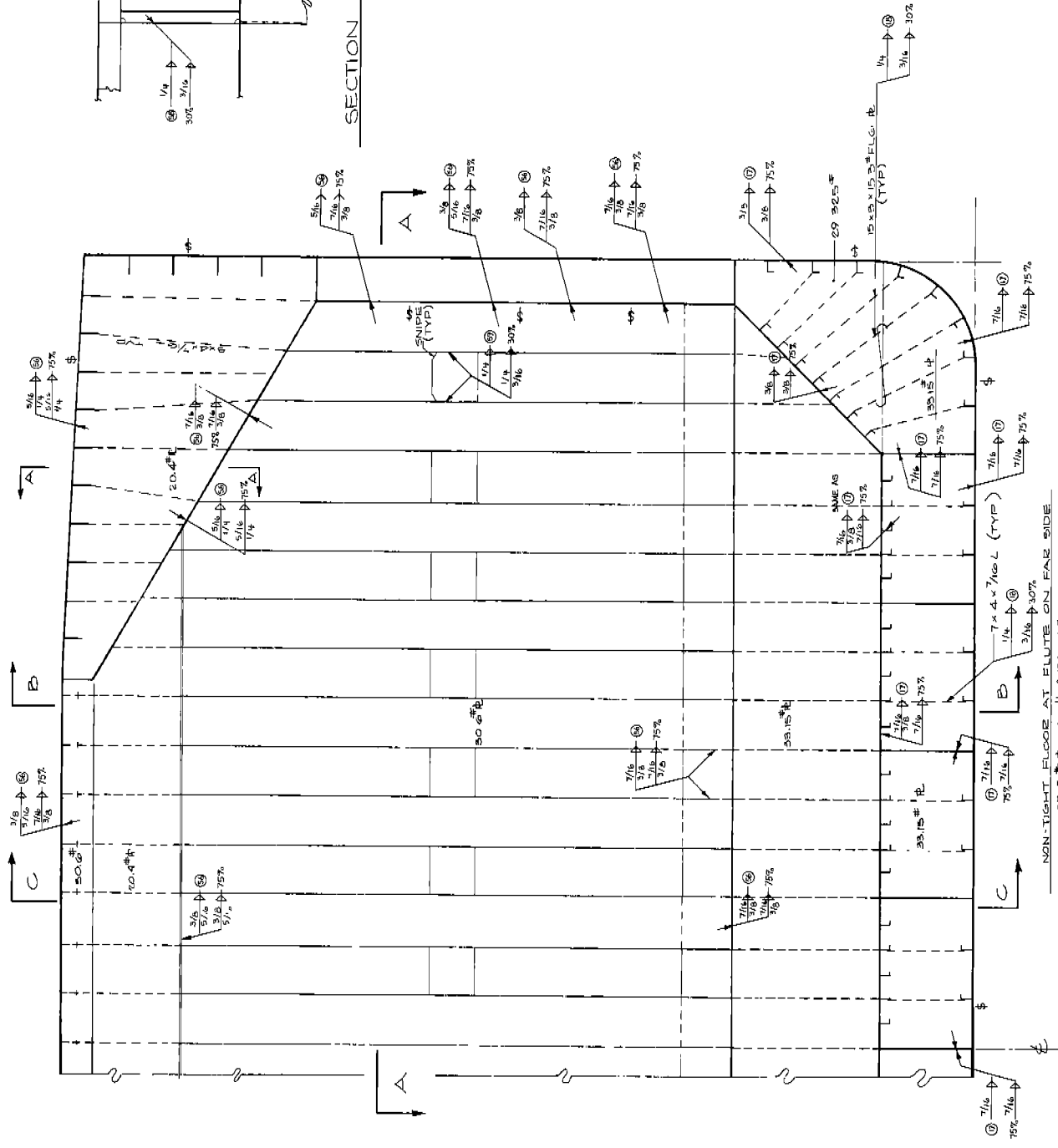

85%

G-5

486-330 (201)

TYPICAL TRANSVERSE WT BULKHEAD OF CRESCENT CLASS ORE/BULK/OIL CARRIER

FIGURE G-3

85%

G-6

486-330-202

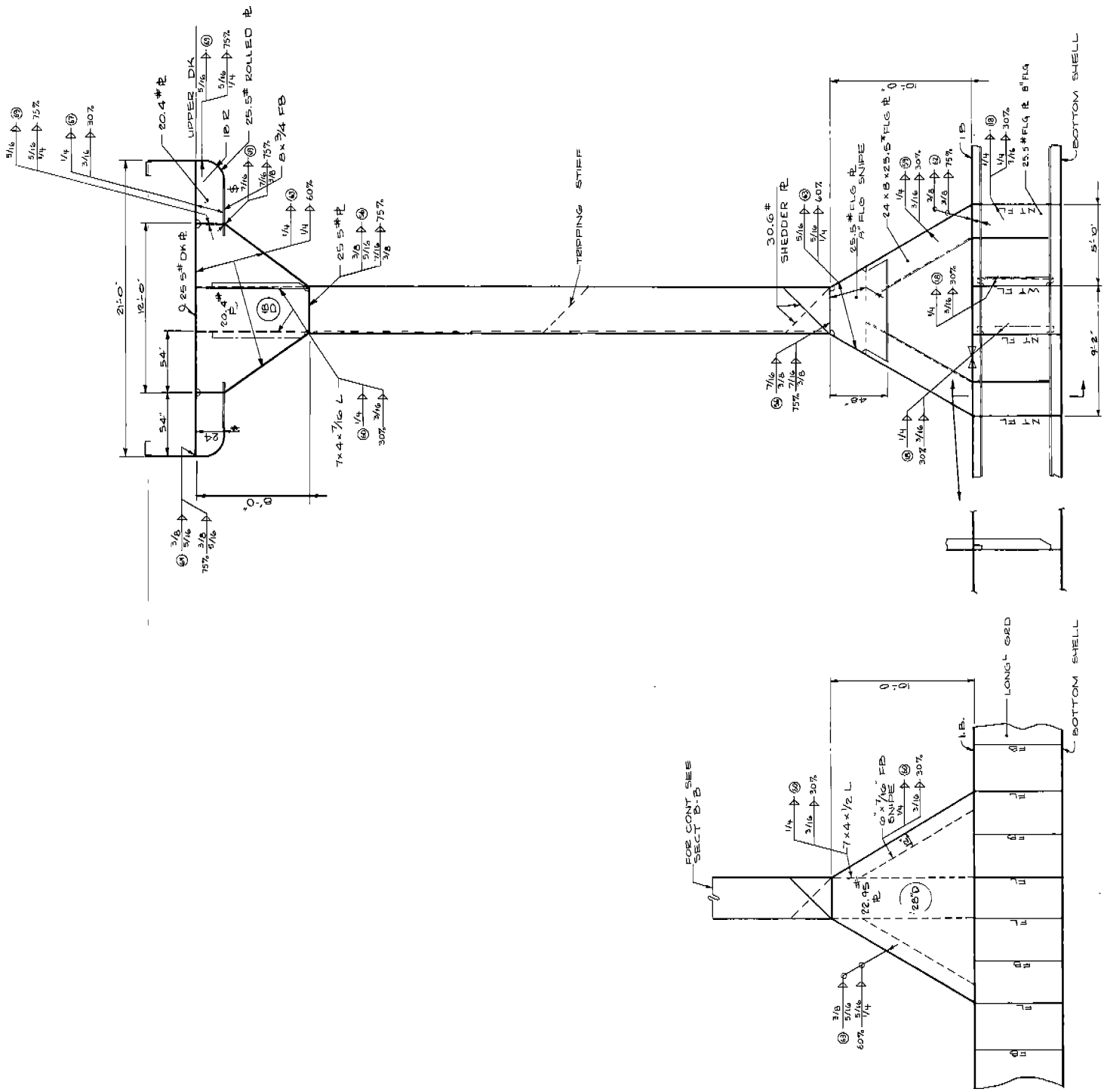

FIGURE G-4
TYPICAL TRANSVERSE BULKHEAD STIFFENING OF CRESCENT CLASS ORE/BULK/OIL CARRIER

TABLE G-1

LENGTHS AND WEIGHTS OF ALTERED WELDS FOR CRESCENT CLASS ORE/BULK/OIL CARRIER

Item	Length (Feet)	Number Both Sides	Double Fillet Weld Length (Feet)	Weld Size (Inches)		Weld Weight (Pounds)	
				Existing	Proposed	Existing	Proposed
Stringer R (16'-2" ABL) to Side Shell	610	2	1,220	5/16	$\frac{5/16}{1/4}$	405	332
Long'ls. to Hopper Side R	610	14	8,540	1/4	3/16	1,815	1,021
Inner Bottom Long'ls. to Inner Bottom R	610	40	24,400	1/4	3/16	5,185	2,917
Bottom & Bilge Long'ls. to R	610	32	19,520	1/4	3/16	4,148	2,333
Side Girders (N.T.) to Inner Bottom	610	6	3,660	1/4	$\frac{5/16}{1/4}$ (2)	778	997
Side Girders (N.T.) to Bottom Shell	610	6	3,660	1/4	$\frac{5/16}{1/4}$ (2)	778	997
Side Girders (W.T.) to Inner Bottom	610	2	1,220	$\frac{7/16}{3/8}$	9/16 (2)	689	1,312
Side Girders (W.T.) to Bottom Shell	610	2	1,220	1/2	9/16 (2)	1,037	1,312
C.V.K. to Inner Bottom	610	1	610	$\frac{5/16}{1/4}$	3/8 (2)	166	292
C.V.K. to Bottom Shell	610	1	610	1/2	9/16 (2)	519	656
SUBTOTAL-Long'l. Struct. Cargo. Section	-	-	64,660	0.266 avg	0.235 avg	15,520	12,169

486-330 - 203

~~203~~

95%

TABLE G-1, LENGTHS AND WEIGHTS OF ALTERED WELDS FOR CRESCENT CLASS ORE/BULK/OIL CARRIER (Cont'd)

Item	Length (Feet)	Number Both Sides	Double Fillet Weld Length (Feet)	Weld Size (Inches)		Weld Weight (Pounds)	
				Existing	Proposed	Existing	Proposed
Brkt-Upper Dk to Transv Fr (Inbd)	12.5	196	2,450	1/4	$\frac{1/4}{3/16}$	521	407
Brkt-Upper Dk to Shell R	4.0	196	784	5/16	$\frac{5/16}{1/4}$	260	213
Brkt-Shell to Transv Fr (46' ABL)	6.75	196	1,323	1/4	$\frac{1/4}{3/16}$	281	220
Transv Fr to Slanting Wing Tank R	20.5	196	4,018	1/4	3/16	854	480
Transv Fr to Shell R	28.0	196	5,488	1/4	3/16	1,166	656
Transv Fr to Cargo Side Bhd	28.0	196	5,488	1/4	3/16	1,166	656
Stiff to Side Girders (I.B.)	5.75	736	4,232	1/4	3/16	899	506
Docking Brkt to I.B., C.V.K & Bottom R	10.0	196	1,960	1/4	3/16	417	234
Slanting Wing Tank Stiffs. (End Connections)	2.5	392	980	1/4	$\frac{1/4}{3/16}$	208	163
SUBTOTAL-98 Ordinary Transv Fr	-	-	26,723	0.252 avg	0.197 avg	5,772	3,535

486-330-204

956

TABLE G-1, LENGTHS AND WEIGHTS OF ALTERED WELDS FOR CRESCENT CLASS ORE/BULK/OIL CARRIER (Cont'd)

Item	Length (Feet)	Number Both Sides	Double Fillet Weld Length (Feet)	Weld Size (Inches)		Weld Weight (Pounds)	
				Existing	Proposed	Existing	Proposed
Transv Fr to Dk R	15.0	112	1,680	1/4	3/16	357	201
Transv Fr to Sheer & Semi Sheer Strake	9.25	112	1,036	1/4	3/16	220	124
Transv Fr to Slanting Wing Tank R	17.0	112	1,904	1/4	3/16	405	228
Transv Fr to Shell R	36.0	112	4,032	1/4	3/16	857	482
Transv Fr to Cargo Side Bhd	28.0	112	3,136	1/4	3/16	666	375
Floor (Brkts) to Bilge Strake & Bottom R	47.5	112	5,320	$\frac{5/16}{1/4}$	1/4	1,448	1,131
Floors to Inner Bottom & Hopper Sides	36	112	4,032	$\frac{3/8}{5/16}$	5/16	1,633	1,339
Floors to Outbd Side Girder	5.5	112	616	3/8	$\frac{3/8}{5/16}$	295	250
Floors to Outbd Side Girder	5.5	112	616	7/16	$\frac{7/16}{3/8}$	401	348
Stiffeners to Floor R (Bilge)	45.0	112	5,040	1/4	3/16	1,071	602
Stiffeners to Floor R (Except Lower Stools)	5.0	640	3,200	1/4	3/16	680	382
Stiff to N.T. Floors of Webs @Lower Stools	5.0	320	1,600	1/4	$\frac{1/4}{3/16}$	340	266
Bottom & Bilge Long'ls to Floors	0.42	1,792	753	$\frac{5/16}{1/4}$	1/4	205	160
Inner Bottom Long'ls to Floors	0.33	3,024	998	$\frac{3/8}{5/16}$	5/16	404	332
Inner Bottom Long'ls to Collars @Floors	0.33	1,344	444	$\frac{3/8}{5/16}$	5/16	180	147
Slanting Wing Tank Stiffs (End Connections)	3.0	224	672	1/4	$\frac{1/4}{3/16}$	143	112
SUBTOTAL-56 Web Frames	-	-	35,079	0.279 avg	0.233 avg	9,305	6,478



TABLE G-1, LENGTHS AND WEIGHTS OF ALTERED WELDS FOR CRESCENT CLASS ORE/BULK/OIL CARRIER (Cont'd)

Item	Length (Feet)	Number Both Sides	Double Fillet Weld Length (Feet)	Weld Size (Inches)		Weld Weight (Pounds)	
				Existing	Proposed	Existing	Proposed
Brkts (Floor-Side Fr) to Side Shell R	8.0	98	784	1/4	3/16	167	94
Brkts to Bilge PL & Floors to Bottom R	47.5	98	4,655	$\frac{5/16}{1/4}$	1/4	1,267	989
Floors to Inner Bottom & Hopper Sides	36	98	3,528	$\frac{3/8}{5/16}$	5/16	1,429	1,171
Floors to Outbd Side Girder	5.5	98	539	3/8	$\frac{3/8}{5/16}$	258	218
Floors to Outbd Side Girder	5.5	98	539	7/16	$\frac{7/16}{3/8}$	351	304
Stiffeners to Floor R (Bilge)	45.0	98	4,410	1/4	3/16	937	527
Stiffeners to Floor R	5.0	784	3,920	1/4	3/16	833	469
Bottom & Bilge Long'ls to Floors	0.42	1,568	659	$\frac{5/16}{1/4}$	1/4	179	140
Inner Bottom Long'ls to Floors	0.33	2,646	873	$\frac{3/8}{5/16}$	5/16	354	290
Inner Bottom Long'ls to Collars @Floors	0.33	1,176	388	$\frac{3/8}{5/16}$	5/16	157	129
SUBTOTAL-49 Solid Floors	-	-	20,295	0.293 avg	0.251 avg	5,932	4,331



TABLE G-1, LENGTHS AND WEIGHTS OF ALTERED WELDS FOR CRESCENT CLASS ORE/BULK/OIL CARRIER (Cont'd)

Item	Length (Feet)	Number Both Sides	Double Fillet Weld Length (Feet)	Weld Size (Inches)		Weld Weight (Pounds)	
				Existing	Proposed	Existing	Proposed
Upper Stool \mathbb{R} to Deck \mathbb{R}	49.0	20	980	$\frac{3}{8}$ $\frac{5}{16}$	$\frac{7}{16}$ $\frac{3}{8}$ (2)	397	553
Stiffeners to Bhd \mathbb{R} (Upper Wing Area)	80.0	20	1,600	1/4	3/16	340	191
Stiff to Diaph \mathbb{R} Within Upper Stool	6.5	340	2,210	1/4	3/16	470	264
Diaph \mathbb{R} (Upper Stool) to Transv \mathbb{R} Stiff	3.0	300	900	5/16	$\frac{5}{16}$ $\frac{1}{4}$	299	245
Brkt (Upper Stool) to Rolled \mathbb{R}	3.5	300	1,050	5/16	$\frac{5}{16}$ $\frac{1}{4}$	349	286
Brkt (Upper Stool) to Dk \mathbb{R} & Tank Overhead \mathbb{R}	6.5	300	1,950	1/4	3/16	414	233
Tank Overhead \mathbb{R} and Chock to Transv \mathbb{R} Stiff	49.0	40	1,960	7/16	$\frac{7}{16}$ $\frac{3}{8}$	1,276	1,106
Tripping Stiffener to Bhd \mathbb{R}	8.0	150	1,200	1/4	$\frac{1}{4}$ $\frac{3}{16}$	255	199
Stiffeners to W.T. Floor	5.0	160	800	1/4	3/16	170	96
Stiffeners to W.T. Floor (Bilge Area)	53.0	20	1,060	1/4	3/16	225	127
W.T. Floor to Inner Bottom \mathbb{R}	40.0	20	800	$\frac{7}{16}$ $\frac{3}{8}$	7/16(2)	452	521
Inner Bottom Long'l's to W.T. Floors & Collar \mathbb{R}	3.38	400	1,352	$\frac{7}{16}$ $\frac{3}{8}$	7/16(2)	763	880
Long'l Portion of Bhd Flutes to Upper Stool	3.33	210	699	$\frac{3}{8}$ $\frac{5}{16}$	$\frac{7}{16}$ $\frac{3}{8}$ (2)	283	395
Brkt to \mathbb{R} and Stiff (Lower Stool)	14.75	200	2,950	5/16	$\frac{5}{16}$ $\frac{1}{4}$	979	803
Stiffeners to \mathbb{R} (Lower Stool)	8.75	360	3,150	1/4	3/16	669	377
Diaphs Above Long'l G's to \mathbb{R} (Lower Stool)	27.0	90	2,430	$\frac{3}{8}$ $\frac{5}{16}$	$\frac{5}{16}$ $\frac{1}{4}$	984	662
Stiff on Diaphs Above Long'l G's (Lower Stool)	38.0	90	3,420	1/4	3/16	727	409
Bhd Periphery to Cargo Side Bhd	5.5	20	110	5/16	$\frac{7}{16}$ $\frac{3}{8}$ (2)	37	62
Bhd Periphery to Cargo Side Bhd	7.5	20	150	$\frac{3}{8}$ $\frac{5}{16}$	$\frac{7}{16}$ $\frac{3}{8}$ (2)	61	85
Bhd Periphery to Cargo Side Bhd	7.5	20	150	3/8	$\frac{7}{16}$ $\frac{3}{8}$ (2)	72	85
SUBTOTAL - 10 Bulkheads	-	-	28,921	0.306 avg	0.278 avg	9,222	7,579



TABLE G-1, LENGTHS AND WEIGHTS OF ALTERED WELDS FOR CRESCENT CLASS ORE/BULK/OIL CARRIER (Cont'd)

Item	Length (Feet)	Number Both Sides	Double Fillet Weld Length (Feet)	Weld Size (Inches)		Weld Weight (Pounds)	
				Existing	Proposed	Existing	Proposed
Transv Fr to Slanting Wing Tank R	17.0	20	340	1/4	<u>1/4</u> 3/16	72	56
Transv Fr to Shell R	36.0	20	720	1/4	3/16	153	86
Transv Fr to Cargo Side Bhd	28.0	20	560	1/4	3/16	119	67
Floors (Brkts) to Bilge Strake & Bottom R	47.5	20	950	<u>5/16</u> 1/4	1/4	259	202
Floors to Inner Bottom & Hopper Sides	36	20	720	<u>3/8</u> 5/16	5/16	292	239
Floors to Outbd Side Girder	5.5	20	110	3/8	<u>3/8</u> 5/16	53	45
Floors to Outbd Side Girder	5.5	20	110	7/16	<u>7/16</u> 3/8	72	62
Stiffeners to Floor R (Bilge)	45.0	20	900	1/4	3/16	191	108
Stiffeners to Floor R	5.0	160	800	1/4	3/16	170	96
Bottom and Bilge Long'ls to Floors	0.42	320	134	<u>5/16</u> 1/4	1/4	36	28
Inner Bottom Long'ls to Floors	0.33	540	178	<u>3/8</u> 5/16	5/16	72	59
Inner Bottom Long'ls to Collars @ Floors	0.33	240	79	<u>3/8</u> 5/16	5/16	32	26
SUBTOTAL-10 Transv Bhd Fr	-	-	5,601	0.283 avg	0.237 avg	1,521	1,074
SUBTOTAL-ALL CARGO SECTION STRUCTURE	-	-	181,279	0.277 avg	0.239 avg	47,272	35,166
ESTIMATE FOR BOW, STERN, AND DECKHOUSE (1)	-	-	32,630	0.277 avg	0.239 avg	8,512	6,337
TOTALS	-	-	213,909	0.277 avg	0.239 avg	55,784	41,503

NOTES:

- (1) The 610 foot long cargo section is assumed to be prismatic. Therefore, the length and weight estimates for the cargo section should be slightly high. This is compensated for by deliberately underestimating weld lengths and weights for the bow, stern, and deckhouse.
- (2) Proposed weld sizes which are increased from existing values are highlighted by reference to this note.

TABLE G-2

LENGTHS AND WEIGHTS OF UNALTERED WELDS FOR CRESCENT CLASS ORE/BULK/OIL CARRIER

Item	Length (Feet)	Number	Total Length of Double Fillet Welds (Feet)	Design Weld Size (Inches)	Weight of Design Welds (Pounds)
Long'l. Hatch Coaming to Upper Dk.	40.0	18	720	$\frac{5}{16}$ $\frac{1}{4}$	196
Deck Long'l's to Deck \mathbb{R}	610.0	20	12,200	$\frac{3}{8}$ $\frac{5}{16}$	4,942
Long'l's to Shearstrake & Semi-Shearstrake	610.0	8	4,880	$\frac{3}{8}$ $\frac{5}{16}$	1,977
Stringer 44'-8-5/8" ABL to Shell	610.0	2	1,220	$\frac{7}{16}$ $\frac{3}{8}$	689
Cargo Side Bhd to Stringer 44'-8-5/8" ABL	610.0	2	1,220	5/16	405
Cargo Side Bhd to Stringer 16'-2" ABL	610.0	2	1,220	$\frac{7}{16}$ $\frac{3}{8}$	689
SUBTOTAL-LONG'L STRUCT CARGO SECT	-	-	21,460	0.349 Avg.	8,898
Side Fr. & Brkt. to Stringer 44'-8-5/8" ABL	5.0	196	980	1/4	208
Side Fr. to Stringer 16'-2" ABL	2.5	196	490	1/4	104
Flg \mathbb{R} (20.4#) to Lower Side Shell & Hopper Side	10.4	196	2,038	1/4	433
W.T. Side Girder Stiffener to Inner Bottom	1.0	196	196	5/16	65
SUBTOTAL-98 ORDINARY TRANSV. FR.	-	-	3,704	0.254 Avg.	810
Transv. Fr. Brkt. (upper Dk. to Slanting Wing Tank)	20.0	112	2,240	1/4	476
Brkt. (Side Shell Stiff. to Slanting Wing Tank Stiff.)	5.75	112	644	1/4	137
Side Fr. & Brkt. to Stringer 44'-8-5/8" ABL	5.0	112	560	1/4	119
Side Fr. to Stringer 16'-2" ABL	2.25	112	252	1/4	54
Floors to Side Girders & C.V.K.	11.0	392	4,312	$\frac{3}{8}$ $\frac{5}{16}$	1,747
SUBTOTAL-56 WEB FRAMES	-	-	8,008	0.305 Avg.	2,533



TABLE G-2 (Cont'd)

Item	Length (Feet)	Number	Total Length of Double Fillet Welds (Feet)	Design Weld Size (Inches)	Weight of Design Welds (Pounds)
Wing Tank Bhd PL Periphery	79.25	20	1,585	$\frac{5/16}{1/4}$	432
W.T. Bhd PL to Upper Stool PL	140.0	10	1,400	$\frac{3/8}{5/16}$	567
W.T. Bhd PL to Slanting Wing Tank PL	30.8	20	616	$\frac{7/16}{3/8}$	348
W.T. Bhd PL to Cargo Side Bhd	7.0	20	140	$\frac{7/16}{3/8}$	79
Bhd PL to Lower Side Shell, Hopper Side & Lower Stringer	25.0	20	500	3/8	239
Floors to Bottom Shell & Bilge PL	58.25	20	1,165	7/16	758
Floors to Side Girders & C.V.K.	12.33	90	1,110	7/16	722
Shedder PL to Bhd	9.0	300	2,700	$\frac{7/16}{3/8}$	1,524
W.T. Bhd PL to Lower Stool PL	196.67	10	1,967	$\frac{7/16}{3/8}$	1,110
Upper Stool Diaph. PL Periphery	31.75	170	5,398	1/4	1,147
SUBTOTAL-10 BHDS	-	-	16,581	0.351 Avg.	6,926
Brkt. - Upper Dk to Transv. Fr. (Inboard)	20.2	20	404	1/4	86
Transv. Fr. to Stringer 44'-8-5/8" ABL	5.0	20	100	1/4	21
Transv. Fr. to Stringer 16'-2" ABL	2.0	20	40	1/4	9
Floors to Side Girders & C.V.K.	5.5	140	770	$\frac{3/8}{5/16}$	312
SUBTOTAL-10 TRANSV. BHD. FRG.	-	-	1,314	0.310 Avg.	428
Floors to Side Girders & C.V.K.	5.5	686	3,773	$\frac{3/8}{5/16}$	1,528
SUBTOTAL-SOLID FLOORS	-	-	3,773	0.344 Avg.	1,528
Dk PL Periphery @ Hatch Opening Trans. Edge	49.0	18	882	$\frac{3/8}{5/16}$	357
Transv. Hatch Coaming	49.0	18	882	$\frac{5/16}{1/4}$	240
SUBTOTAL-MISC.	-	-	1,764	0.315 Avg.	597
SUBTOTAL-ALL CARGO SECTION STRUCT.	-	-	(56,604)	(0.336)	(21,720)
ESTIMATE FOR BOW, STERN, AND DECKHOUSE	-	-	10,189	0.336 Avg.	3,911
TOTALS	-	-	66,793	0.336 Avg.	25,631

486-380 - 210



MIDSHIP SECTION - 1981 ABS RULES

(Terms are as defined in ABS Rules unless noted otherwise)

Principal Dimensions

LOA 871'-0"
 B 106'-0"
 D 60'-0"
 Values at scantling draft:
 d 44'-3"
 LWL 847'-9"
 LBP 827'-0"

Weights (Long Tons)

Light Ship		17,400
Fuel Oil	3,300	
D.O. & L.O.	50	
Fresh water	280	
Crew & Stores	50	
Cargo	69,520	
TOTAL DEADWEIGHT		73,200
DISPLACEMENT		90,600
(at scantling draft)		

REQUIRED SECTION MODULUS - MILD STEEL

Section 2.1 Scantling length = $L = 0.97 \times \text{LWL} = 822.32'$

Section 6.3.1(a) $SM = M_t / f_p$
 $f_p = 10.56 - \frac{L-790}{2045} = 10.576 \text{ LT/in}^2$

Section 6.3.1(b) $C_1 = 0.01441 \left[10.75 - \left(\frac{984-L}{328} \right)^{1.5} \right] = 0.14992$
 $C_b = \frac{\text{Displacement} \times 35 \text{ ft}^3/\text{LT}}{L \times B \times d} = 0.82212$

Min. $SM = 0.01C_1 L^2 B (C_b + 0.70) = 163,567 \text{ in}^2 \text{ ft}^2$

Section 6.3.2 (a) $C_{st} = \left[0.275 - \frac{L-820}{11,600} \right] 10^{-3} = 0.27480 \times 10^{-3}$
 $M_{sw} = C_{st} L^{2.5} B (C_b + 0.5) = 746,785 \text{ Ft-LT}$

Section 6.3.2(b) $K_b = 1.0$
 $C_2 = [6.53 C_b + 0.57] 10^{-4} = 5.9384 \times 10^{-4}$
 $H_e = [4.5L - 0.00216L^2 + 335] 10^{-2} = 25.748 \text{ Ft}$



$$M_w = C_2 L^2 B H_e K_b = 1,095,975 \text{ Ft-LT}$$

$$M_t = M_{sw} + M_w = 1,842,760 \text{ Ft-LT}$$

$$SM = M_t / f_p = 174,240 \text{ in}^2 \text{ Ft (96 and 91\% of 1970 ABS Rules Deck and Baseline values)}$$

REQUIRED MOMENT OF INERTIA AND SECTION MODULUS - H32 STEEL

Section 6.13.2 $I_{H32} = L \times SM / 34.1 = 4,201,790 \text{ in}^2 \text{ Ft}^2$

Section 6.13.3 $Q = 0.78050$ (see page E-11)

$$SM_{H32} = Q(SM) = 135,994 \text{ in}^2 \text{ Ft}$$

SCANTLINGS

Use H32 material in deck and bottom structure with mild steel elsewhere.

Reduce 61.2# deck and sheer strake to 58.65#

Resulting properties:

$$I = 4,427,616 \text{ in}^2 \text{ ft}^2 > 4,201,790 \text{ in}^2 \text{ ft}^2$$

$$SM_{dk} = 140,980 \text{ in}^2 \text{ ft} > 135,994 \text{ in}^2 \text{ ft}$$

$$SM_{\underline{L}} = 154,844 \text{ in}^2 \text{ ft} > 135,994 \text{ in}^2 \text{ ft}$$

Neutral axis is 28.594 Ft above \underline{L}

MAXIMUM HULL GIRDER SHEARING FORCE

Section 6.3.3(a) $V_p = F_{sw} + F_w$

Section 6.3.3(b) $V_p = 5.0 M_{sw}/L + 2.6 M_w/L = 8006.0 \text{ LT}$



SIMPLIFIED STRESS ANALYSIS FOR BOTTOM LONGITUDINALS

Bottom longitudinals are rolled 9" x 4" x 9/16" AH 32 angles with 40" spacing on 35.7# DH 32 bottom plate and spans of 5'-0".

Section 3.9 Effective plate width = (5' x 12"/')/3 = 20"

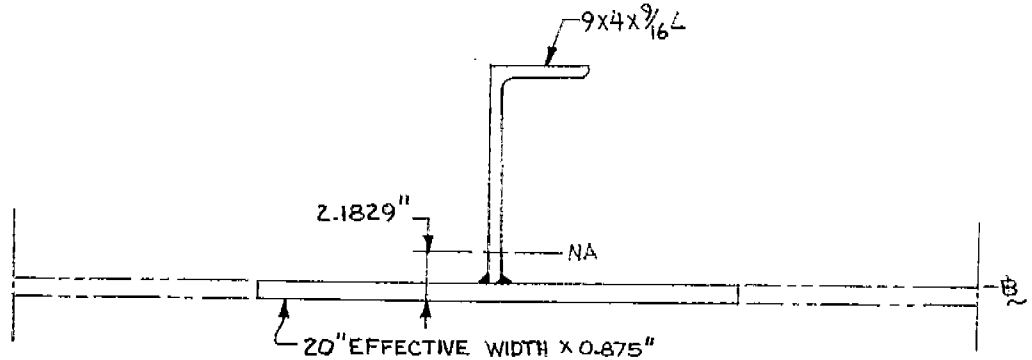

Section 7.3.8 $c = 1.30$
 $h = 44.25$ Ft
 $L = \text{Span} = 6$ Ft minimum
 $s = \text{Spacing} = 3.333$ Ft

Design Load on Longitudinal=

$$64\#/Ft^3 \times 44.25 \text{ Ft} \times 6 \text{ Ft} \times 3.333 \text{ Ft} = 56,634\#$$

Actual Load on Longitudinal=

$$64\#/Ft^3 \times 44.25 \text{ Ft} \left[5 \text{ Ft} \times 3.333 \text{ Ft} - \frac{4}{2} \left(\frac{3.333 \text{ Ft}}{2} \right)^2 \right] = 31,465\#$$

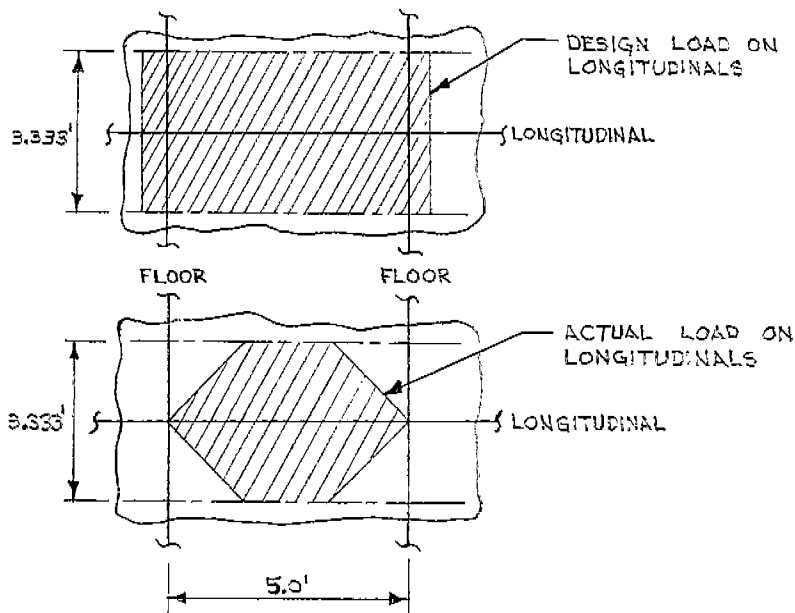

G-17



Design stresses for O/B/O H32 bottom structure

Section 6.3.1(a)
and 6.13.3

$$\sigma_p = 10.576 \text{ Lt/in}^2 / 0.7805 = 30,353 \text{ PSI}$$

Section 7.3.8 and
Page E-24

$$\sigma_s = 15,610 / (1.30 \times 0.7805) = 15,385 \text{ PSI}$$

$$\sigma_T = 45,738 \text{ PSI}$$

Section 6.3.3 &
6.13.3

$$\tau_p = 6.75 \text{ Lt/in}^2 / 0.7805 = 19,372 \text{ PSI}$$

Use 60% of σ_s

$$\tau_s = 0.6 (15,385) = 9,231 \text{ PSI}$$

$$\tau_T = 28,603 \text{ PSI}$$

Primary Strength Values, $V_p = 8006.0 \text{ LT} = 17,933,440\#$
 $(AY)_p = 16.404 \text{ in. Ft}^2$
 $I_p = 4,427,616 \text{ in}^2 \text{ Ft}^2$

Secondary Strength Values, Design $V_s = 28,317\#$
 Actual $V_s = 15,733\#$
 $(AY)_s = 30.544 \text{ in}^2$
 $I_s = 246.7 \text{ in}^4$

$$T_r = \frac{1}{\tau_T} \left[\frac{V_p (AY)_p}{I_p} + \frac{V_s (AY)_s}{I_s} \right]$$

$D = 0.668 (T_r) + 0.085"$ for H32 steel.

For design load, $T_r = \frac{1}{28,603 \text{ \#/in}^2} [66.4 \text{ \#/in.} + 3505.9 \text{ \#/in.}] = 0.12489 \text{ in.}$

$$D = 0.668 (0.12489") + 0.085" = 0.1684" < 0.1875" \text{ OK}$$

For actual load, $T_r = \frac{1}{28,603 \text{ \#/in}^2} [66.4 \text{ \#/in.} + 1947.9 \text{ \#/in.}] = 0.070423 \text{ in.}$

$$D = 0.668 (0.070423") + 0.085" = 0.1320" < 0.1875" \text{ OK}$$

STRIP IMPRINT →