

SSC-359

**HYDRODYNAMIC HULL
DAMPING
(PHASE I)**

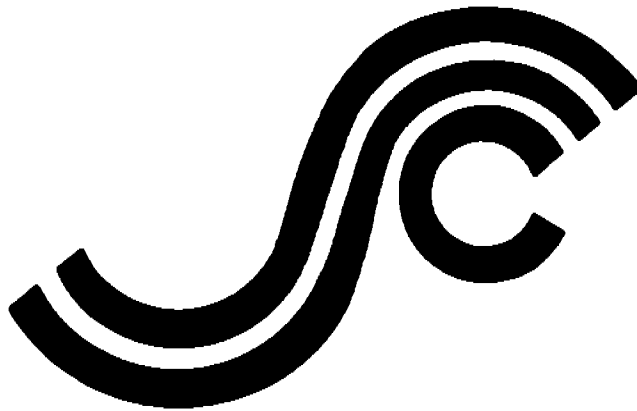

This document has been approved
for public release and sale; its
distribution is unlimited

SHIP STRUCTURE COMMITTEE

1991

SSC-359

Hydrodynamic Hull Damping (Phase I)

Ship Structure Committee 1991

SHIP STRUCTURE COMMITTEE

The SHIP STRUCTURE COMMITTEE is constituted to prosecute a research program to improve the hull structures of ships and other marine structures by an extension of knowledge pertaining to design, materials, and methods of construction.

RADM J. D. Sipes, USCG, (Chairman)
Chief, Office of Marine Safety, Security
and Environmental Protection
U. S. Coast Guard

Mr. H. T. Haller
Associate Administrator for Ship-
building and Ship Operations
Maritime Administration

Mr. Alexander Malakhoff
Director, Structural Integrity
Subgroup (SEA 55Y)
Naval Sea Systems Command

Mr. Thomas W. Allen
Engineering Officer (N7)
Military Sealift Command

Dr. Donald Liu
Senior Vice President
American Bureau of Shipping

CDR Michael K. Parmelee, USCG,
Secretary, Ship Structure Committee
U. S. Coast Guard

CONTRACTING OFFICER TECHNICAL REPRESENTATIVES

Mr. William J. Siekierka
SEA 55Y3
Naval Sea Systems Command

Mr. Greg D. Woods
SEA 55Y3
Naval Sea Systems Command

SHIP STRUCTURE SUBCOMMITTEE

The SHIP STRUCTURE SUBCOMMITTEE acts for the Ship Structure Committee on technical matters by providing technical coordination for determining the goals and objectives of the program and by evaluating and interpreting the results in terms of structural design, construction, and operation.

AMERICAN BUREAU OF SHIPPING

Mr. Stephen G. Arntson (Chairman)
Mr. John F. Conlon
Dr. John S. Spencer
Mr. Glenn M. Ashe

NAVAL SEA SYSTEMS COMMAND

Mr. Robert A. Sielski
Mr. Charles L. Null
Mr. W. Thomas Packard
Mr. Allen H. Engle

MILITARY SEALIFT COMMAND

Mr. Albert J. Attermeyer
Mr. Michael W. Touma
Mr. Jeffery E. Beach

U. S. COAST GUARD

CAPT T. E. Thompson
CAPT Donald S. Jensen
CDR Mark E. Noll

MARITIME ADMINISTRATION

Mr. Frederick Seibold
Mr. Norman O. Hammer
Mr. Chao H. Lin
Dr. Walter M. Maclean

SHIP STRUCTURE SUBCOMMITTEE LIAISON MEMBERS

U. S. COAST GUARD ACADEMY

LT Bruce Mustain

U. S. MERCHANT MARINE ACADEMY

Dr. C. B. Kim

U. S. NAVAL ACADEMY

Dr. Rameswar Bhattacharyya

STATE UNIVERSITY OF NEW YORK MARITIME COLLEGE

Dr. W. R. Porter

WELDING RESEARCH COUNCIL

Dr. Martin Prager

NATIONAL ACADEMY OF SCIENCES - MARINE BOARD

Mr. Alexander B. Stavovy

NATIONAL ACADEMY OF SCIENCES - COMMITTEE ON MARINE STRUCTURES

Mr. Stanley G. Stiansen

SOCIETY OF NAVAL ARCHITECTS AND MARINE ENGINEERS - HYDRODYNAMICS COMMITTEE

Dr. William Sandberg

AMERICAN IRON AND STEEL INSTITUTE

Mr. Alexander D. Wilson

Member Agencies:

*United States Coast Guard
Naval Sea Systems Command
Maritime Administration
American Bureau of Shipping
Military Sealift Command*



**Ship
Structure
Committee**

An Interagency Advisory Committee
Dedicated to the Improvement of Marine Structures

April 10, 1991

Address Correspondence to:

Secretary, Ship Structure Committee
U. S. Coast Guard (G-MTH)
2100 Second Street, S.W.
Washington, D.C. 20593-0001
PH: (202) 267-0136
FAX: (202) 267-4816

SSC-359
SR-1307

HYDRODYNAMIC HULL DAMPING
(PHASE 1)

Hull girder vibrations are a major concern for ship designers and operators. Vibrations have been cited as the cause of structural and mechanical failures and crew discomfort. If the vibration damping factors used in the design of a vessel are inaccurate, the expected hull girder vibratory response can be greatly in error. This report presents research findings and principal program elements to conduct ship vibration damping measurements and assessments.

J. D. SIPES
Rear Admiral, U.S. Coast Guard
Chairman, Ship Structure Committee

1. Report No. SSC-359		2. Government Accession No.		3. Recipient's Catalog No.	
4. Title and Subtitle Hydrodynamic Hull Damping (Phase I)				5. Report Date JUNE 1987	
				6. Performing Organization Code	
7. Author(s) V. Ankudinov				8. Performing Organization Report No. SR-1307	
9. Performing Organization Name and Address Tracor Hydronautics, Inc. 7210 Pindell School Road Laurel, MD 20727				10. Work Unit No. (TRAIS)	
				11. Contract or Grant No. DTCG23-85-C-20074	
12. Sponsoring Agency Name and Address Commandant U.S. Coast Guard 2100 Second Street, SW Washington, DC 20593				13. Type of Report and Period Covered Final Report	
				14. Sponsoring Agency Code G-M	
15. Supplementary Notes Sponsored by the Ship Structure Committee and its member agencies.					
16. Abstract <p>Hull girder vibrations are a major concern for ship designers and operators and are a priority in the ship design process. Significant efforts are made to decrease vibrations levels and to reduce damage and noise attributed to vibrations. Attenuation of ship vibration is an important aspect of ship design. This report contains a research plan for ship vibration damping, including analytical calculations, model testing, and full scale measurements. The major elements of this effort included: a) collection and analysis of vibration damping information, b) preparation of a model testing and data analysis plan, and c) preparation of a full-scale testing and data analysis plan. Discussions of specific techniques and recommended procedures are presented in summary form with appropriate references cited. Recommendations represent the state-of-the-art in vibration technology at the time the report was finalized.</p>					
17. Key Words Hull Damping Hydrodynamic Damping Damping Coefficient Vibration Prediction Ship Vibrations			18. Distribution Statement Available from: Nat'l Technical Information Service Springfield, VA 22161 or Marine Tech. Information Facility National Maritime Research Center Kings Point, NY 10024-1699		
19. Security Classif. (of this report) Unclassified		20. Security Classif. (of this page) Unclassified		21. No. of Pages 174	22. Price

METRIC CONVERSION FACTORS

Approximate Conversions to Metric Measures

Symbol	When You Know	Multiply by	To Find	Symbol
LENGTH				
in	inches	2.5	centimeters	cm
ft	feet	30	centimeters	cm
yd	yards	0.9	meters	m
mi	miles	1.6	kilometers	km
AREA				
in ²	square inches	6.5	square centimeters	cm ²
ft ²	square feet	0.09	square meters	m ²
yd ²	square yards	0.8	square meters	m ²
mi ²	square miles	2.6	square kilometers	km ²
	acres	0.4	hectares	ha
MASS (weight)				
oz	ounces	28	grams	g
lb	pounds	0.45	kilograms	kg
	short tons (2000 lb)	0.9	tonnes	t
VOLUME				
tsp	teaspoons	5	milliliters	ml
Tbsp	tablespoons	15	milliliters	ml
fl oz	fluid ounces	30	milliliters	ml
c	cup	0.24	liters	l
pt	pints	0.47	liters	l
qt	quarts	0.95	liters	l
gal	gallons	3.8	liters	l
ft ³	cubic feet	0.03	cubic meters	m ³
yd ³	cubic yards	0.76	cubic meters	m ³
TEMPERATURE (exact)				
°F	Fahrenheit temperature	5/9 (after subtracting 32)	Celsius temperature	°C

*1 in = 2.54 exactly. For other exact conversions and more detailed tables, see NBS Misc. Publ. 286, Units of Weights and Measures, Price \$2.25, SD Catalog No. C13.10:286.

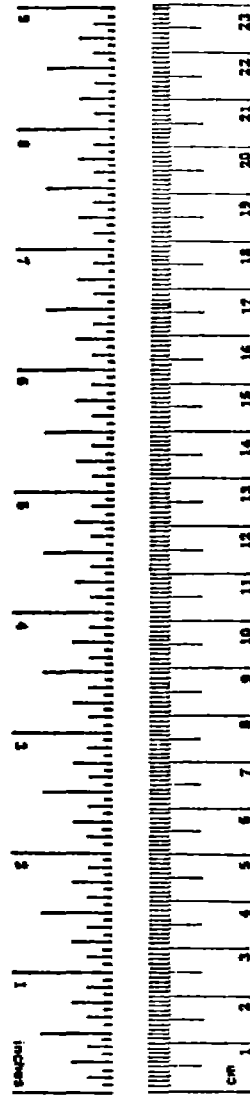

Approximate Conversions from Metric Measures

Symbol	When You Know	Multiply by	To Find	Symbol
LENGTH				
mm	millimeters	0.04	inches	in
cm	centimeters	0.4	inches	in
m	meters	3.3	feet	ft
m	meters	1.1	yards	yd
km	kilometers	0.6	miles	mi
AREA				
cm ²	square centimeters	0.16	square inches	in ²
m ²	square meters	1.2	square yards	yd ²
km ²	square kilometers	0.4	square miles	mi ²
ha	hectares (10,000 m ²)	2.5	acres	
MASS (weight)				
g	grams	0.035	ounces	oz
kg	kilograms	2.2	pounds	lb
t	tonnes (1000 kg)	1.1	short tons	
VOLUME				
ml	milliliters	0.03	fluid ounces	fl oz
l	liters	2.1	pints	pt
l	liters	1.06	quarts	qt
l	liters	0.26	gallons	gal
m ³	cubic meters	35	cubic feet	ft ³
m ³	cubic meters	1.3	cubic yards	yd ³
TEMPERATURE (exact)				
°C	Celsius temperature	9/5 (then add 32)	Fahrenheit temperature	°F

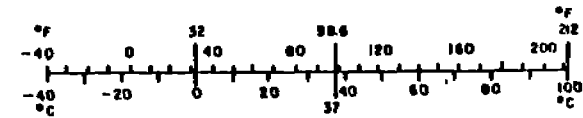

METRIC CONVERSION FACTORS

TABLE OF CONTENTS

	Page
1.0 INTRODUCTION	1-1
2.0 ASSESSMENT OF THE PROBLEM	2-1
2.1 Background	2-1
2.2 Definition of Ship Vibration Damping	2-3
2.3 Analysis of Existing Methodologies for Ship Damping Evaluation	2-12
2.4 Ship Vibration Prediction Methods and Effects of Damping	2-34
3.0 PHASE II - MODEL TEST PLAN AND CALCULATION PROCEDURES	3-1
3.1 Objectives	3-1
3.2 Scope of Model Test Program	3-2
3.3 Model Test Theoretical and Numerical Procedures	3-4
3.4 Analytical Methods and Calculation Procedures ..	3-5
3.5 Recommended Problem Solution	3-5
3.6 Plan for Model Testing and Damping Components Analysis	3-14
3.7 Excitation and Damping Coefficient Identification	3-17
3.8 Model Test Procedures	3-23
3.9 Correlation of Calculated and Experimental Results	3-28
3.10 Estimated Schedule and Level of Effort	3-31
4.0 PLAN FOR FULL-SCALE DAMPING EXPERIMENTS, PHASE III ..	4-1
4.1 Objectives	4-1
4.2 Ship Selection	4-2
4.3 Measurement and Data Analysis Techniques	4-5
4.4 Excitation Devices	4-6
4.5 Location and Magnitude of the Excitation	4-11
4.6 Measuring and Recording Instrumentation	4-12
4.7 Analysis of Test Data	4-13
4.8 Full Scale Test Parameters	4-15
4.9 Summary of Full Scale Test Program	4-17
4.10 Work Scope	4-20

LIST OF FIGURES

	Page
Figure 1 - Variation of Damping Coefficient Along the Ship for Different Vibration Modes (Reference 12)	2-60
Figure 2 - Typical Vibration Test Data Analysis Using Circle-Fitting Parameter Method	2-61
Figure 3 - Damping Coefficients Determined by Various Investigators	2-62
Figure 4 - Damping Coefficient Identified by Different Analysis Methods for a Car Ferry (Reference 12)	2-63
Figure 5 - Comparison of Damping Coefficients Determined by Steady State and Transient (Impulsive) Excitation (Reference 12)	2-64
Figure 6 - Experimental and Computed Dimensionless Amplitude and Phase Angle of Sloshing Moment, From Reference 41	2-65
Figure 7 - Effect of Ship Proportions on the Hull Flexibility (Represented by the Two-Node Frequency), From Reference 55	2-66
Figure 8 - Finite Element Model of Multi-Purpose Ship for Strength and Vibration Analysis	2-67
Figure 9 - Example of Variation of Solid Boundary Factors Including Influence from Free Surface Effects, Reference 59. Dotted Lines Represent the Value $S = 2.0$	2-68
Figure 10 - Resonant Frequencies of Hull Structure Related to Vibration Mode and Excitation	2-69
Figure 11 - Added Mass Coefficient for Heave	2-70
Figure 12 - Heave Damping Coefficient	2-71
Figure 13 - Coefficient of Added Mass Moment of Inertia for Pitch	2-72
Figure 14 - Pitch Damping Coefficient	2-73
Figure 15 - Zero-Speed Motion Coefficients for Series 60, $C_B = 0.70$ Hull Model, From Reference 67	2-74
Motion Coefficients for Series 60, $C_B = 0.70$ at $Fr = 0.20$, From Reference 67 (Concluded) ..	2-75
Figure 16 - Numerical Predictions of Ship Hydrodynamic Forces from Reference 44	2-76
Figure 17 - Approximate Location of Excitation Devices ...	3-33

LIST OF TABLES

	Page
Table 1 - Damping Coefficients, C/C_{cr} , Estimated From the Tests in Reference 36	2-24
Table 2 - Analysis of Components of Ship Vibration Damping	2-28
Table 3 - Effect of Cargo on Damping, From Reference 11 ..	2-77
Table 4 - Summary of Capabilities of Some Structural Numerical Codes	2-79
Table 5 - Scaling Relationships for Prototype and Model ..	3-35
Table 6 - Principal Characteristics of Some Rotating Mass Exciters	4-8

1.0 INTRODUCTION

Vibration has been a major concern for ship designers and operators, and, therefore, vibration analysis has been the subject of numerous studies for many years. More recently it has assumed a greater priority in the overall ship design process because of the greater attention given to the effects of vibration on the structural integrity of the ship and ship operations. Significant efforts are being undertaken to decrease the level of vibration in attempts, to reduce damage and noise caused by vibration. The cost of damage from vibration is significantly underreported. Damage from vibration may have been a major contributor to some casualties. (See Reference 1). In the discussion of Reference 2, Smogeli reported that of 41 ships measured by Det Norske Veritas on sea trials, 24 experienced vibration problems. Recent studies have linked fatigue failures in ship hulls to hull vibrations, as noted in Reference 3. Therefore, attenuation of ship vibration is an important design requirement for any type of vessel.

Faced with the task of insuring that the vessel will not be subject to vibration in excess of commonly established limits, designers try to avoid vibrational resonance, i.e., coincidence between natural frequencies and excitation frequencies within the operational speed range of the vessel. In practical structural design to avoid the occurrence of resonance, however, it is almost impossible to avoid the occurrence of resonance because many modes of vibration are included in ship response. Resonant conditions could occur either in the high density band of the frequency spectrum of the vibrating structure or in the frequency range of the dynamic loading. Resonant conditions are inevitable during starting or stopping of engines and propellers. Wide frequency

random vibrations, such as ship hull vibration in irregular ocean waves, are typically of resonant nature, since a dynamic system with relatively small damping behaves like a narrow-band frequency filter. In such a system, the excitation component is amplified with the same system natural frequency, and all other components are suppressed.

Since damping is a dominant factor in resonant vibrations, inaccuracy in the estimated damping values could result in large errors in the prediction of the vibratory responses. The ship designer must be able to determine the vibration damping value associated with the particular mode of vibration of concern. Unfortunately, at the present time it is unlikely that he will be able to do this with any degree of confidence.

Responding to this specific need, the United States Coast Guard in cooperation with the Interagency Ship Structure Committee awarded a contract to Tracor Hydronautics, Inc. to develop a research program plan for ship vibration damping, including analytical calculations, model testing, and full-scale measurements. In accordance with the principal objectives of the project, the proposed program includes three major elements:

- Collection and analysis of information on ship vibration damping
- Preparation of a plan for model testing and data analysis
- Preparation of a plan for full-scale testing and data analysis

This final report incorporates all the research findings and presents a preliminary plan for ship vibration damping measurements and assessment.

The ship vibration damping research program has been of primary concern to the Ship Structure Committee and is consistent with the long range goals of the SSC. This report was preceded by an extensive series of model tests, computer analyses, and full-scale data collection projects related primarily to the effects of ship configuration and materials on hull flexibility, bending and vibratory stresses. For example, it is generally recognized that the SL-7 research program was the most comprehensive coordinated surface ship seaway response research program ever undertaken. The program was a multi-element research project which included analytical predictions, model testing, and full-scale measurements of seaway loads and responses. Although the analytical and experimental work was performed for the SL-7 containership, the techniques used were generally applicable to other ship types.

A similar program on ship vibration damping is envisioned by the SSC. The overall project objective is to create a fundamental and reliable data base on ship vibration damping by integrating calculation procedures, model tests, and full-scale verification measurements in a consolidated and coordinated program.

This report includes a description of the proposed principal program elements and planned correlation of the results. Implementation of this program should provide the maritime community with much needed data on ship vibration damping and will also result in better understanding of the damping phenomenon and the development of engineering recommendations and guidelines for ship designers.

The subject of vibration damping is too extensive to be reviewed in depth in this report. Accordingly, the discussions of the specific techniques and procedures recommended are presented in summary form and appropriate references are cited where appropriate. The recommendations made in this report represent the present state-of-the-art on the subject. It is possible that the proposed detailed experimental and analytical studies in the future will point in directions which cannot be foreseen today.

2.0 ASSESSMENT OF THE PROBLEM

2.1 Background

The current status of ship vibration analysis is characterized by an uncoordinated development of the major elements of the subject. Although significant efforts have been made recently, particularly in the evaluation of the frequencies and modes of hull vibration as reported in References 4 through 8, there is still no authoritative literature on those aspects of the phenomenon which are directly associated with the prediction of vibration amplitudes and dynamic stresses. The principal reasons for this situation are:

a) Much of the work done in the past has been fragmentary. Several papers on theoretical analyses and some on measured values for ships have been published, e.g. References 9 and 10. Most of the latter are of limited use outside of the context of the particular measurements reported, and the validity of the former has yet to be proved.

b) There are a large number of variables associated with the damping of vibration modes of a ship underway. In the past neither theoretical nor experimental work has been initiated to explore some of the more significant factors.

c) Until approximately five years ago the measurement of damping values was extremely difficult and time consuming. The measurement techniques have not been developed to a degree which would provide a standard method for the rapid collection of these data.

Each of the above obstacles could absorb considerable research effort and further research must be carefully planned if a useful understanding of the subject is to be achieved.

The fact that vibrational damping prediction is still a major impediment to practical application is due to a great extent to the following difficulties:

(a) Ship vibrational damping is not readily considered by theoretical analysis and modeling.

(b) A reliable quantitative assessment of ship vibrational damping is possible only by means of costly full-scale testing, as indicated in References 11 and 12.

(c) Ship vibrational damping consists of several components of different physical natures. Present experimental methods are not capable of separating and considering these components as functions of ship geometry, loading condition, frequency and mode of oscillation, as stated in References 8 and 11.

(d) Vibration damping measurement are usually not included in the routine vibration measurements during ship trials, and therefore, special full-scale testing must be conducted in order to accumulate and evaluate damping data.

(e) There are significant discrepancies in the existing experimental data, even for tests involving similar vessels. Results of the statistical analysis of these data are frequently disappointing and often meaningless.

At this time, despite significant progress on the subject, practical methodologies which overcome most of these difficulties have not been identified.

To maximize the usefulness of the proposed total program by integrating research results and test data, the following questions also should be addressed:

a. What damping information is required by the vibration specialist to facilitate prediction of the resonant vibration amplitudes of a ship in service?

b. What depth of understanding is necessary to ensure that this information will be used with confidence for a wide range of ships and environmental conditions?

c. How should this information be presented with respect to format and engineering codes and procedures?

2.2 Definition of Ship Vibration Damping

The subject of ship damping cannot be fully understood until it can be described mathematically. In order to reach this point the results of theoretical studies must be assessed by correlation with data obtained by measuring the dynamics of a corresponding physical model. Ideally, the physical model should be a complete ship structure, but the range and number of variables to be investigated is so wide that the cost and effort required to obtain meaningful results would be prohibitive, and, for some tests, impossible. Accurate modeling requires consideration of ship vibration theory, hydrodynamics, structural mechanics, and rules of similitude. Therefore, it is necessary to use a scale model for most of the experimental

work and to carry out only the final correlation assessment at full scale.

Another problem complication is that, theoretically and physically, damping coefficients cannot be determined directly from the experiments. Only the responses of the ship to certain excitation can be measured. Based on assumed theoretical models and results of measured responses, the values of damping coefficients can then be established. The quantitative identification of damping requires the application of the proper mathematical formulation to the specifically designed and analyzed test measurements.

Perhaps the simplest approach to the definition of damping will be through the measurements of the dissipated energy of the system. In the absence of damping, once a system is excited and set into motion theoretically the motions will continue indefinitely. As a consequence of damping, some energy is dissipated, and a continuous source of energy is required to maintain these motions. In the steady state, the energy generated by the excitation is equal to the energy dissipated. There are several difficulties in this approach, however:

(a) There are inevitable additional energy losses by the exciting devices, their supports and foundations, including local structure.

(b) In non-linear coupled responses identification of the particular model damping component is an extremely difficult theoretical and numerical problem.

(c) Mechanisms of energy dissipation of the basic vibration damping components (structural, cargo, and hydrodynamic) differ greatly and are not well understood, as discussed in References 13 through 17. These contributions are different depending on structure, cargo and frequency range. In addition, damping changes from point to point along the hull because the energy is not dissipated uniformly in the ship structure. See Reference 12 and Figure 1 taken from Reference 12.

Although no engineering methodology to determine damping from energy dissipation has yet evolved many of the developed techniques are indirectly based on energy dissipation concept. In regard to the energy dissipation, the ship vibration damping is customarily separated into the following main types:

2.2.1 Components of Ship Vibration Damping

a) Hysteretic Damping - Hysteretic damping includes material damping due to the energy losses caused by irreversible internal processes. These losses typically accompany the cyclic deformation of a solid material and convert strain energy to heat. This phenomenon is due to the local microplastic strains in the nonhomogeneous material of ship structures. This component is thought to be small but might increase significantly from stress concentration.

Hysteretic damping also includes structural damping due primarily to the energy losses in the structural joints during bending and shear of the hull girder. Structural damping also increases in the areas of stress concentration. Recently it has been established that the damping that occurs in a joint subjected to relative interfacial slip is due to a complex

process of elastic and plastic deformation, microslip and macro-slip, as discussed in Reference 18. Hysteresis of the structural joints is much higher than that of the ship hull material. The main sources of joint damping are working, slipping and fraying of overlapping connected elements. This component is believed to be a dominant factor in vibration damping. An exhaustive review of hull damping of internal origin may be found in a paper by Betts et al, Reference 14. A survey of recent studies on damping in structural joints was presented by C. F. Beards in Reference 19.

b) Cargo Damping - The term "cargo" is defined here to include all the ship's contents other than fixed structures and equipment. The four major categories of interest are: (1) solid cargo, (2) loose dry cargo, (3) liquids, and (4) spring masses. Some researchers question whether spring masses should be included under the term "damping". Furthermore, cargo damping may be treated as hysteretic in the case of solid cargo and is of a hydrodynamic type for liquid cargoes. Very little is known about cargo damping. Some experimental data exists but the information is scanty and perhaps of limited and questionable reliability and applicability.

c) Energy Losses Due to Resonance - These losses are typically associated with the resonant vibrations of various local structures and equipment, including superstructure, machinery, fittings, etc. The losses become larger at higher modes, possibly due to the fact that more local structure becomes involved.

d) External (Hydrodynamic) Damping - This form of damping includes:

- Viscous damping due to skin friction and eddies,
- Pressure wave generation due to propeller operation,
- Surface wave generation due to ship motion, and
- Wavemaking due to ship forward speed.

Hydrodynamic damping can be studied somewhat differently than other components of vibration damping. Unlike structural damping it can be estimated using a variety of available analytical and numerical hydrodynamic methods. A theoretical approach can be formulated on the basis of well established concepts of fluid dynamics. Currently there are several advanced computer programs to predict external fluid forces on a ship hull resulting from almost any disturbances. Although hydrodynamic damping accounts for only a small fraction of the total energy losses, there is very limited information on the magnitude of this component.

2.2.2 Mathematical Definition of Damping - A general definition of damping from the theoretical point of view can be symbolically outlined as follows:

Let L be a mathematical operator (assumed functional relation) representing the specific method, P_i , $i = 1, \dots, n$ to ship parameters such as dimensions, stiffeners, loading, etc., X be the response vectors, including, deflection, bending moments, etc., C the damping coefficients, and F be the force or excitation vector. Then the equations of motion

$$L(P_i, C) X = F \quad [1]$$

can be resolved to yield the response vectors

$$X = L^{-1} (P_i, C) F \quad [2]$$

Inverse matrix L^{-1} symbolically can be expressed as the sum of the following components:

$$L^{-1}(P_i, C) = G_i(P_i) + Q_1(C_s) + Q_2(C_h) + Q_3(C_o)$$

$$i = 1, \dots, n \quad [3]$$

Then

$$X = [G_i(P_i) + Q_1(C_s) + Q_2(C_h) + Q_3(C_o)]F \quad [4]$$

where G_i , Q_1 , Q_2 , Q_3 are functions of different damping coefficients and C_s , C_h , and C_o are the structural, hydrodynamic, and cargo damping coefficients, respectively defining a non-linear response, X , due to the excitation, F .

Equation [4] containing damping in the implicit form could be a starting point for damping identification and its further determination as a function of ship parameters, ship responses and frequencies. As stated in Reference 20 this approach might provide, for a given excitation, "useful values of the modal damping coefficients which could be stored after they have been sorted according to ship type and mode characteristics, therefore constituting some sort of a catalog of damping coefficients which could be used in future calculations of similar ship types".

The solution of Equation [4] in regard to the damping coefficients is a difficult task. Application of the System Identification Procedure is recommended. This procedure involves identifying the known or measured parameters with their expected formulations and estimating the unknown terms. In this case, these terms are the damping coefficients. The

least square or other appropriate method can be used to minimize errors. This procedure is relatively new but has been successfully applied, together with the extended Kalman filter technique, for identification of the parameters in the complicated non-linear dynamic system, primarily in electrical and hydromechanics problems. See References 21 and 22. For general engineering applications, System Identification consists of determining and identifying the proper dynamic equations of the system, with respect to form and magnitude of the coefficients, by comparing and analysing the output of the system caused by a given input to the system. This is a somewhat inexact process since a given measured numerical value of the integrand is inherently limited to the "assumed" set of dynamic equations, and the results are shown to be quite sensitive to availability of accurate, high-resolution measured data, as well as to the methods of regression analysis controlled by error and truncation criteria. A somewhat simplified version of this procedure for ship vibration analysis is described in Reference 23. A 3-D finite element model of the hull and superstructures was correlated with the response measured in the excitation test. The calculated responses at the main resonant frequencies were modified to obtain the best possible selection of damping values. It should be cautioned, however, that the damping estimated by this procedure is not actually "true" but rather an "equivalent" damping and to a significant degree is a function of the analytical model and, possibly, of the condensation technique used.

It should also be noted that the analytical model, no matter how detailed, represents the total behavior only to a limited extent. Nevertheless, the derived values in Reference 21 were in good agreement with normally accepted damping values for hull and superstructure.

The general methodology described by Equations [1] through [4] could be used to isolate the effects of different damping components. Suppose, for example, the cargo is removed from the vessel, and the hydrodynamic damping can be estimated with reasonable accuracy. Then the structural damping coefficient becomes:

$$C_s = Q_1^{-1} [X F^T - G_i(P_i) - Q_2(C_h)] \quad [5]$$

where F^T is the transfer of F .

Q^{-1} is the inversion of Q_i .

There is an obvious strong correlation between theory and experiment. Regardless of the accuracy of the measured responses, X , it is recognized that correct values of the structural damping can only be determined by means of a reliable theoretical model.

If a ship is considered to be a single-degree-of-freedom system, operator L in Equation [1] reduces to

$$L = M \frac{\partial^2}{\partial t^2} + C \frac{\partial}{\partial t} + K \quad [6]$$

where $M = M + M_s$, where M_s and M are total mass and added mass, respectively. The equation of motion of the complete structure may be written in matrix form as

$$[M]\ddot{q} + [C]\dot{q} + [K]q = F(t) \quad [7]$$

where $[M]$ is the mass matrix,

$[C]$ is the damping matrix,

$[K]$ is the stiffness matrix,

q is the vector of (unknown) nodal displacements, and

$F(t)$ is the vector of (known) applied nodal forces.

Unless the damping is everywhere proportional to mass, the terms associated with damping are coupled for various modes. However, the system defined by [7] can be solved numerically in explicit form with all coupled terms taken into consideration. See Reference 11. If damping is assumed to be proportional to mass, an assumption which results in decoupling the set of equations of motion [1], the so-called normal coordinates, r , can be introduced. System [7] may then be rewritten in the form of n independent equations, n being the total number of degrees of freedom of the structure, i.e.,

$$\ddot{r}_i + 2\zeta_i \omega_i \dot{r}_i + \omega_i^2 r_i = R_i(t) \quad (i = 1, 2, \dots, n) \quad [8]$$

where ζ_i is the damping coefficient for the i -th mode. It can be shown that this assumption is valid if the damping matrix is a linear combination of the stiffness and mass matrix. For a constant damping ratio for all frequencies, Rayleigh damping can be assumed and damping matrix [C] can be expressed as

$$[C] = \alpha[M] + \beta[K] \quad [9]$$

where α = mass damping coefficient and
 β = stiffness damping coefficient.

For a single degree of freedom system, the ratio of actual critical damping, ζ , can be expressed as

$$\zeta = \frac{\alpha}{2\omega} + \frac{1}{2} \beta \omega \quad [10]$$

where ω = frequency of mode under consideration.

Damping coefficients are often identified differently by the various types of measurements and data analysis techniques. The most commonly used descriptions for damping are presented below. The basis for some of these methods will be briefly discussed in succeeding sections of this report.

1. Equivalent viscous damping coefficient, $(C/\mu\omega)$
2. Logarithmic decrement, (δ)
3. Magnification factor, (Q)
4. Amplification factor, (A)
5. Damping ratio, $\zeta = C/\text{critical damping} = C/C_c$
6. Dissipation factor, (η)

The following cross relationships and conversions exist among these quantities:

$$C/\mu\omega = \delta/\pi = 2\zeta = 2C/C_c = 1/Q = 1/A = \eta \quad [11]$$

It should be emphasized again that these relationships are based on linear single-degree-of-freedom systems.

2.3 Analysis of Existing Methodologies for Ship Damping Evaluation

In an exhaustive review of ship vibration damping conducted two decades by W. E. Woolam, References 24 and 25, he concluded that existing information is inadequate for ship response predictions at resonant conditions. A more recent survey conducted by P. Y. Chang and T. P. Carroll in 1981, Reference 11, showed that this situation has changed very little. In 1985, the 9th International Ship Structure Congress concluded that "little reliable data concerning damping is available worldwide because of the complexity of this parameter and the uncertainties associated with its identification."

For this report, an analysis of over 200 sources related to ship vibration damping has confirmed that despite the apparent abundance of information in recent publications, vibration specialists are still unable to reliably predict damping for a particular ship hull, even for the simplest (and usually the most important) case of a two-mode vertical vibration.

In the following paragraphs, some analysis procedures for the damping identification are presented, together with the numerical estimates of the effectiveness and problems with some procedures. In addition to consideration of the appropriate test procedure, the damping identification analysis should also include consideration of the test methodology, acquisition and treatment of the signal, all of which have a substantial effect on the quality of the final results.

2.3.1 Excitation methods - The following types of excitation are typically applied to the ship (or model):

- steady state
- impulsive
- random or pseudo-random

(a) Steady-State (Step-Wise and Swept-Sine) Excitations

This is the most widely used method because it provides at once the transfer function of a linear system as a rate of the input-output Fourier transform. However, it requires the frequency variation of the input signal to be slow in order to avoid the transient period, and to achieve a steady state. Theoretically, transient or non-harmonic vibration responses can be analyzed in the time domain using the known explicit

solutions for some simple cases. See, for example, results shown in Reference 11.

This type of excitation is commonly used with harmonic exciters, References 11, 20, and 26, and considered to have the best signal-to-noise ratio at the measurement frequency of all excitation techniques. Disadvantages of the steady-state excitation are:

- Requires excessive time to obtain a transfer function for all practical frequency ranges.
- Provide a very poor linear approximation of a strongly nonlinear system.

The last characteristic is common for most of the known excitation methods. However, in the case of steady-state excitation a possibility of more complicated vibration damping coefficient variation based on the premise that the energy input due to the excitation should be equal to the energy dissipated might be considered. An example is quadratic damping which, in ship motions analysis, particularly in roll, can be a main source of damping. The damping coefficient associated with the product of the velocity and its absolute value is also considered to be of viscous type, and originates from the so-called "cross-flow-drag" phenomena.

(b) Impulsive Excitation

Frequency response of the structure is obtained with an impact load, since an impact can be considered as an approximation of an impulse function which contains energy in the wide frequency band.

Impact tests in ship vibration are generally performed using two common types of actuators: wave impact (slamming and sweeping, References 12 and 14), and hammers, Reference 27. There have been recommendations for dropping an anchor for vibration tests, but only Reference 28 has been found regarding relevant applications of this actuator to the identification of the modal parameters of the ship hull.

In order to obtain satisfactory results by this type of excitation, the following requirement should be met:

- Impact forces should be large enough to produce measurable response amplitudes. For large vessels this could be a major problem.

- This method requires sophisticated instrumentation with high sensitivity detectors possessing low signal-to-noise ratio and proper analysis technique.

- For systems with low damping, when the response slowly decays within the duration of sampling, truncation of the record and leakage error problems should be minimized. However, if there is too much damping, noise becomes a problem due to the fast decrease of the measuring signal. In addition, since an impact has a high ratio of peak to rms energy content, it tends to excite all the nonlinearities in a system, and, for a strongly nonlinear system, identification of damping in a linear sense might become questionable.

(c) Pseudo-Random Excitation - This type of testing has become a practical method of frequency response measurement and damping identification, although it is somewhat of a novelty in ship vibration analysis, as indicated in Reference 29. The

excitation signal is created in the frequency domain as a random sum of simple harmonic components of variable amplitudes in which energy content is described by the particular energy spectrum. Using the Fourier transformation, it is easily transformed to the time domain to become a "pseudo-random" input. The following are the advantages in this procedure:

- Both the amplitude and frequency content of the excitation signal can be precisely controlled.
- By the selection of the appropriate energy spectrum (amplitude variation) and random number generator (frequency variation), practically any time-domain vibration problem can be reproduced with a limited number of components and in the practical range of model frequencies.
- It is fast and efficient since the development of the specialized digital analyzers and the current easy availability of the efficient FFT program on most computer systems.
- It has a low ratio of peak to rms energy.
- Leakage errors are minimized by using a random periodic input within a specified frequency range.
- Noncoherent noise can be easily identified and conveniently averaged using available filtering techniques with minimal disturbance of the energy content of the record.

The following are inherent difficulties in this method:

- The energy input at any frequency is relatively small compared to swept-sine. However, the situation can be corrected however by choosing a special shaped spectra.

- Relatively high sensitivity to rattle which appears as regular spikes on the frequency response results. The spikes can be mistakenly identified as model parameters and can cause difficulties in curve-fitting of the test data.

2.3.2 Vibration Analysis Methods - The ship response depends both on the magnitude of the exciting forces and on the dynamic properties of the system at the excitation frequency, which, in linear systems, is associated with the transfer function concept.

The frequency response identifiable as a dynamic response of the system to a given unit excitation typically has peaks corresponding to the natural frequencies. Their amplitudes depend on the energy associated with the point at the actual mode as well as on damping. Therefore, identifying the ship vibratory response implies knowing its modal parameters, i.e., natural frequencies, modes, and damping. The most commonly used or promising analysis procedures for the identification of the modal parameters, and specifically the vibration damping, are described below with appropriate references. In the order of their complexity these methods are:

- Response Curve Method (RCM);
- Phase Variation method (PVM);
- Logarithmic Decrement Method (LDM);
- Phase Separation Method (PSM);
- Exponential Method (EM);
- Phase Resonance Method (PRM);
- Maximum Entropy Method (MEM);
- Circle Fitting Parameter Estimation Method (CFPE);
- Analytical Identification Procedure (AIP).

Discussion of some of these methods is given in References 8, 11, 24, and 25.

Most of these methods were initially developed for a steady-state excitation (single frequency), and later extended to the frequency domain (PSM, PRM, and RCM). However, even time-domain methods, such as the exponential method, EM, can be applied to the analysis of exciter test response using inverse Fourier transforms.

(a) The Response Curve Method - This method derives directly from the characteristic equation of single degree of freedom systems, References 5 and 12. The absolute value of the transfer function can be written:

$$|H(\omega)| = \frac{1}{\sqrt{\left(1 - \frac{\omega^2}{\omega_n^2}\right)^2 + 4\zeta \frac{\omega^2}{\omega_n^2}}} \quad [12]$$

which at resonance, $\omega = \omega_n$, yields

$$|H_{\max}| = |H(\omega_n)| = \frac{1}{2\zeta}$$

For slight variations around the resonance, we can assume that $\omega = \omega_n + \Delta\omega$. Substituting in [12] and dropping higher-order terms, one obtains:

$$|H| = 1/2 \sqrt{\Delta\omega^2/\omega_n^2 + \zeta^2} \quad [13]$$

The amplitude near the resonance can be expressed as a fraction of the maximum, i.e.:

$$H = \left| \frac{H_{\max}}{n} \right| = \frac{1}{2\zeta_n}, \quad (n > 1) \quad [14]$$

Combining the above expressions, the following expression for the damping coefficient can be derived

$$\zeta = \frac{\Delta\omega}{\omega_n \sqrt{n^2 - 1}} \quad [15]$$

(b) The Phase Variation Method - This method is based on the well known fact that damping is proportional to the phase angle between the excitation and response near a resonance. See Reference 20. The damping coefficient, ζ , is estimated by the following formula

$$\zeta = \frac{\omega_0^2 - \omega^2}{2\omega_0 \cdot \omega} \operatorname{tg} \psi \quad [16]$$

where: ω_0 is the resonance circular frequency;
 ω is a circular frequency close to ω_0 ;
 $\operatorname{tg} \psi$ is the tangent of the phase angle between
excitation and response at ω .

The main problem in using this method is that the phase angle curve exhibits a sharp drop as it approaches the resonance frequency.

(c) The Logarithmic Decrement Method - The method is based on the measurement of the decay of the free vibrations of the ship or its model, and widely used in model and full-scale vibration testing because of its simplicity and consistency of the results, References 24, 25, 30, and 31. The logarithmic decrement is evaluated by the following relationship:

$$\delta = \frac{1}{K} \frac{\ln a_n}{\ln a_{n+K}}, \quad \zeta = \delta/2\pi \quad [17]$$

where a_n is the first amplitude observed
 K is the number of observed periods.

Therefore, the method easily identifies the damping coefficient from test data, but it becomes less reliable at higher frequencies. There are difficulties in this method such as:

- For large vessels, the excitation should be large to generate measurable response.
- The coupling of the modes, due to damping, makes it difficult to separate the contributions of the significant modes of vibration (this is especially true in cases where the frequencies are close together).
- The measured responses include components from many modes and it is difficult to separate the effects of local structural response and the effects of the excitation device from the hull girder response.

(d) The Phase Separation Method - The method belongs to the "normal mode testing," and based on the modal transformation of the linearized transfer function in the complex domain, Reference 12.

The advantage of this approach lies in the fact that, in addition to mass and stiffness (known values), the damping matrices (unknown variables) are involved in the modal transformation. The damping matrix is assumed to be the imaginary part of a complex stiffness matrix, and is determined using a polynomial matrix approach.

(e) The Exponential Method - This method used at CETENA has evolved from the optimization of an exponential algorithm to analyze short and non-periodic decayed signals in time-domain, Reference 8. Therefore, it might be applied to the the impulsive response obtained by inverse Fourier transformation of the frequency response operator resulting from the steady state vibration tests.

Numerical values in time domain, $X(n, \Delta t)$ are expressed by the sum of the M exponential functions of the Laplace variables:

$$X(n, \Delta t) = \sum_{j=1}^M A_j \exp(S_j n \Delta t) \quad (n = 0, 1, \dots, 2N - 1) \quad [19]$$

Then the numerical problem is reduced to a system of Van der Moude linear equations in complex domain which is solved on the basis of the optimization criteria of the auto-regressive series. As a result of this test fitting optimization procedure complex amplitudes, frequency and damping coefficients can be numerically deduced.

(f) The Phase Resonance Method - The method is based on the assumption that damping matrix is proportional to the mass and stiffness matrix (proportional damping), see Equation [9]. The mode shapes are identified through a finite-difference approach on adjacent spectral lines of the response operator, Reference 12. A linearized transfer function in complex domain is presented by the next equation:

$$H(s) = \sum_1^m k \frac{r_k}{2j(s-p_k)} + \frac{r_k^*}{2j(s-p_k^*)} \quad [20]$$

where s = Laplace variable = $-\sigma + j\omega$

p_k = pole of transfer function = $-\sigma_k + j\omega_k$

p_k^* = complex conjugate of pole p_k

r_k = complex residue of mode (mode shape).

The iterative algorithm uses a least-square estimation method, based on the minimization of the following error terms:

$$\epsilon = \sum_{i=1}^N (H_i - H(\omega_i))^2 \quad [21]$$

where H_i = measured data at frequency i ;

$H(\omega_i)$ = analytical model data at frequency i ;

N = number of spectral lines of the response operator.

For each iteration of the algorithm, the modal parameters (damping, frequencies and mode shapes) are again estimated, thus gradually minimizing the error between the measured data and the analytical model.

g) The Maximum Entropy Method - This method appears to be a promising time domain modeling technique for ship vibration application, as discussed in Reference 32. It is based on an extension of the auto-correlation function model which provides the required frequency resolution and it belongs to the currently popular Auto Regressive Moving Average (ARMA) models, References 33 and 34. The success of this approach lies in the fact that if the dynamic equations are written in state space form, it becomes possible to apply many standard signal processing techniques to the field of structural dynamics. In this way, natural frequencies, damping ratios, and mode shapes are explicitly estimated. Applications of this technique to time domain test records benefit from the robustness of the

ARMA model identification in relation to nonstationarity, and its ability to discriminate close eigen-frequencies. Because of these advantages over spectral analysis based on FFT techniques, the method proved particularly useful for analyzing real sea experiments and ship dynamic responses where the natural excitation is not controlled.

h) Circle-Fitting Parameter Estimation - This method was developed at BSRA as a robust vibration analysis method for quick identification of the major modal parameters, Reference 35, and works as follows:

- Firstly, modes and natural frequencies are established by the inspection of the response curves.
- Secondly, using a least square method, a circle is fitted through points in the vicinity of the natural frequency. Under ideal conditions the polar plot of a vibration response will describe a circle.
- The damping ratio and the modal displacement are defined in amplitude and phase by position and dimension of the circle. A modified version of this method is currently adopted by the British Maritime Industry (BMT) for routine shipboard vibration tests. Figure 2 shows typical results of this procedure for a cargo vessel. The method appears to be robust and efficient.

i) Analytical Identification Procedure - The System Identification procedure was described earlier, and its application for determining damping coefficients through the correlation of the computed and measured response is given in Reference 23.

j) Results of Damping Identification - Woolam, References 24 and 25, and Chang and Carroll, Reference 11, reviewed the vibration damping results and presented a summary of available damping data as a function of ship characteristics, mode number and method of excitation. This chapter briefly summarized some more recent data on vibration damping with special emphasis on the identification procedure used whenever possible.

The current (unsatisfactory) status of damping identification is reflected in Table 1 and Figure 3. The System Identification Procedure applied for damping identification of the LNG vessel and cruise liner in Figure 3 provides realistic results, but attempts to describe damping coefficients by simple formulations appears unsuccessful.

Table 1

Damping Coefficients, C/C_{cr} ,
Estimated From the Tests in Reference 36

Ship Type	Frequency Range	Fraction of Critical Damping %	Notes
Tanker	3.8-13.3	0.9-1.9	
"	3.8-13.3*	1.1-2.5*	
"	5.0-11.5	0.7-1.3*	Full load
"	6.3-12.8	0.8-2.9*	Ballast
"	0.47-13.3	0.9-2.48*	Ball. Shall. Wat.
"	7.0-12.3*	1.0-1.9*	
LNG	4.5-6.7	1.46-1.7	
Container	2.5-15.7	1.85-3.7	

Note: Damping coefficients are primarily determined by the logarithmic decrement method. Values marked with asterisk are obtained using the response curve method.

The damping values increase slightly with the frequency. One possible reason is coupling, and therefore, energy losses are larger at higher frequencies. Extensive study of the different analysis methods (PSM, EM, PRM, and RCM) applied to four vessels is reported in Reference 12. Figures 4 and 5 taken from Reference 12 show some of the results in regard to damping coefficients. Several conclusions can be drawn from these results:

- Natural frequencies and mode shapes are identified satisfactorily by all methods. However, there is large scatter between methods in regard to damping coefficients.
- Damping increases with the frequency.
- Coupling between hull and subsystems leads to higher damping values. In Figure 5, the damping coefficient shows two peaks which correspond to coupled hull-double bottom modes.

2.3.3 Evaluation of Methods - The methods described in the preceding sections are evaluated in the following summary discussion:

(a) Available model and full-scale damping data are limited. Much of the data are proprietary and/or questionable with respect to reliability and accuracy of the tests and analysis.

(b) Despite the apparent significant improvements in test and data analysis techniques, it is not clear which of the methods discussed provides the best overall results with regard to model and vibration damping identification. This is partly due to the fact that most vibration tests and analyses are

performed for commercial clients, and, therefore, the results and methodology are proprietary.

(c) Diversity and shortcomings of the conventional model estimation techniques are well known to vibration specialists. There is a definite tendency in the industry to rely on simple and reliable procedures which provide a consistent data base for purposes of comparison of structural changes in design or modification process. Several investigators in the United States and abroad have introduced specialized vibration analysis packages with the data acquisition systems and computer support for data reduction and modal model estimation. In some cases, effects of structural changes can be evaluated by interrogating a transfer function directly through adding mass, stiffness and damping changes to the original modal model. A typical example of such a system is the Structural Dynamics Research Corporation (SDRC) comprehensive vibration test package MODAL-PLUS which has a Multi-Point Random (MPR) data acquisition capability and several Frequency Response Function (FRF) estimators suited for minimizing the measurement noise encountered in the specific test environment. The FRFs are used to estimate resonance frequencies, damping modal masses and shape of each mode of the system using several conventional estimations techniques, such as circular curve fitting and complex exponential. The system provides a data analysis consistency and multiple choice for customers. In addition, this package includes different curve fitting procedures and error analysis models as well as visual and animated displays to refine and enhance test results. After completing the test analysis, the data can be transferred to a variety of software for more extensive structural dynamic studies.

With regard to ship design needs, a computer-aided diagnostic system for ship structural vibration problems has been developed in Japan, as described in Reference 35a. It consists of three subsystems: on-board data acquisition and processing, data bank, and vibration analysis, all functionally related to each other. The interrelation links allow for the completion of the data bank with selected on-board measurements and analysis results, and for use of these data as the reference base in identification, modification, and diagnostic procedures for other ship hulls and ship structural systems.

(d) There is a lack of more scientific and physics-oriented systematic analysis of vibration damping phenomena, specifically in such areas as:

- Differentiation of damping components.
- Amplitude-frequency and mode dependence as well as forward speed effects on damping.
- Distribution of damping along the ship and effect of local structure.
- Solutions of non-linear vibration problems for highly transient and large amplitude ship responses.
- Analysis of the errors and effects sensitivity of the test data and data reduction techniques on the value of damping.

To date, no results or studies comprehensively solving these problems have been found. However, several sources which address some aspects of these problem areas are reviewed here briefly. No progress in damping identification will likely be achieved without understanding the mechanisms by which the energy can be dissipated in the complicated ship structural

system subjected to the external and internal loads. Significant theoretical and numerical progress has been achieved in describing such losses as hydrodynamic and cargo. However, there are few reliable test data verifying the analytical predictions. This is due to the difficulties in conducting and interpreting the vibration measurements, and, to a certain degree, due to the inherent limitations of the model and full-scale testing. Table 2 below shows that a full-scale test provides only the total damping, and cargo damping. By model experiments, the material, cargo, and hydrodynamic components of the ship damping can potentially be estimated separately under conditions that satisfy all scaling considerations.

Table 2

Analysis of Components of Ship Vibration Damping

Damping Components	Type of Approach		
	Theoretical	Model	Full-Scale
Structural	Few		
Material	+	+	
Cargo	+	+	+
Local Vibration	Few		
Hydrodynamic	+	+	
Total			+

Note: The symbol + indicates cases in which ship damping can be estimated by theoretical methods, model tests, or full scale trials, as indicated.

The following is a synopsis of the major studies on ship damping components by both experiments and theory.

(a) Full Scale Tests - The previous discussion and results shown in Table 1 and Figure 3 are primarily related to the total values of damping measured on ship trials. See References 8, 11, 24, and 36 for more detailed discussion. The method of measuring and evaluating shipboard vibration has evolved over many years and is reflected in the SNAME "Code for Shipboard Vibration Measurements," and accompanying SNAME document "Local Shipboard Structures and Machinery Vibration Measurements," Reference 38. The procedures and methods of measurement and evaluation presented in these documents have been universally accepted and have been used for the International ISO Standard "Code for the Measurement and Reporting of Shipboard Vibration Data." State of the art in shipboard vibration control is reviewed by Noonan and Feldman in Reference 2. Currently full-scale vibration testing is increasingly becoming a major factor in developing and improving the design procedure.

Full-scale data on cargo damping are reviewed in References 11 and 14. Summarized results of several representative studies, are presented in Table 3 taken from Reference 11 which gives a short description of ship type and cargo, value of the measured damping coefficients and reference source. Most of the measurements have been performed for the 2-node vertical bending modes, and only a few are for the 3-node and 4-node modes. It is not possible to make reliable conclusions on the basis of these results.

Shortcomings of past full-scale damping experiments include:

- Lack of systematic tests for various ship types, loadings, frequencies, modes, speeds, restrictions of waterway.

- Few reliable and systematic data in regard to cargo damping. Damping effects of common types of cargo have not been established.

(b) Model Tests - In regard to the hydrodynamic damping, model testing as well as theoretical and numerical predictions are the most comprehensive and complete of all ship damping studies. Recent research activities in modeling and calculations for vibration applications are dominated by efforts to reduce the propeller-induced forces and to examine the influence of the free surface and cavitation on the hull pressure fluctuations, as discussed in Reference 8. Data on effects of variation of ship type models and tested frequency band, specifically for higher frequencies typical for vibration analysis interests, are quite limited.

Model test data on cargo damping are reviewed in Reference 11. Volcy, Reference 36, studied effects of variable cargo, on damping in a series of model tests of a 10 ft tanker model. Results indicate the importance of cargo damping, particularly of coulomb friction damping. For instance, when the model was filled with sand, damping increases as high as a factor of 20 were recorded. Results also point to the importance of the proper scaling of the cargo damping. This is also emphasized in Reference 11.

No data or references have been found to date on model testing for internal damping. Other shortcomings of the past model damping experiments include:

- Limited number of ship model types and frequencies tested.

- Almost no reliable data on cargo damping effects. Inconsistency in proper model scaling.

- No references on model test studies of material damping.

(c) Theoretical Predictions

- Hydrodynamic Damping Components - A large amount of information is available, although there is a need for systematization and sorting. Viscous contribution to the hydrodynamic damping, although considered to be small compared with the fluid pressure forces, has been studied primarily for simple flows and body configurations.

- Cargo Damping - Dynamics of the liquid cargo in closed compartments is thoroughly investigated in connection with missile dynamics, nuclear reactor safety, sloshing problems, refueling operations, dynamics of fluid in oil reservoirs, etc. Advanced numerical techniques have been employed, as in References 39 to 44, to solve the hydrodynamic problem in the most comprehensive manner, i.e., non-linear solution of viscous fluid behavior with exact boundary conditions on the free surface and arbitrarily shaped fluid container. There are a number of available numerical codes, such as IMP, Reference 42, MAC or SMAC, SOLA-VOF and commercially developed HYDRY-3D computer packages which can operate on VAX computers. These numerical algorithms solve viscous flow equations by the finite difference technique for arbitrary flow/body boundaries and commonly require excessive computer time. Numerical results obtained in References 40 and 41 are in very good agreement with experiments, as illustrated on Figure 6 taken from a paper by Van den Bosch and Vugts, Reference 40. With respect to

sloshing, reference should be made to Bass, et al, "Liquid Dynamic Loads in LNG Cargo Tanks," SNAME Transactions, 1980. In combined applications with the FEM, a detailed loading analysis of fluid-filled structures, such as an oil tanker's compartments, can also be examined, as in Reference 45. There are known analytical and numerical models to describe structural behavior using concept of the Coulomb type and "dry friction" models, as in References 46 and 47. Dynamic behavior of bulk cargo such as ore and coal can be modeled mathematically only in a very approximative manner and this subject requires more investigations and specially designed test verifications.

- Internal Vibration Damping - Types of analytical models and results of the experiments on internal damping have been discussed by Betts, Bishop, and Price, Reference 14. W. Voigth (Am. Phys., 1892, Bd. 47, S. 671) suggested the following formula for the normal stress in a vibrating body:

$$\sigma = E \varepsilon + 2 \zeta \dot{\varepsilon} \quad [22]$$

where ε and $\dot{\varepsilon}$ are strain and its time derivative, respectively; E is the Young's modulus, and ζ is the coefficient of "viscous" damping. Equation [22] indicates that the damping force is proportional to the strain velocity, or to the frequency of vibration. Specially conducted tests for single degree of freedom systems confirmed that the Voigth hypothesis results in good agreement between the calculated and measured data, on the condition that the coefficient or proportionality between the damping force and the velocity of vibrations is measured for the system's natural frequency. The hypothesis is commonly used in the standard linear vibration analysis. However, for a multidegree motion system the coefficient of damping appears to be almost constant over a wide range of frequencies.

To account for this phenomenon the following modification to Equation [22] has been suggested,

$$\sigma = E \epsilon + \frac{\zeta}{\omega} E \dot{\epsilon} \quad [23]$$

For harmonic oscillations with the frequency ω , $\dot{\epsilon} = i \omega \epsilon$ and relationship [23] becomes:

$$\sigma = E \epsilon (1 + i \zeta) \quad [24]$$

The frequency independent coefficient of internal damping varies for different materials and also appears to be somewhat of a function of structure geometry and its loading. The table below presents typical values of this coefficient for steel, aluminum, and wood.

Steel	$\zeta = 0.0016 - 0.0050$
Aluminum	$\zeta = 0.0050 - 0.0070$
Wood	$\zeta = 0.011 - 0.017$

Results indicate that compared with the structural damping of the ship hull and its local structures, the internal damping is not a critical factor for structure analysis, and available results allow estimation of its value for typical ship structures. Typical values for local structures are:

Ship bottom structure	$\zeta = 0.064 - 0.095$
Ship masts	$\zeta = 0.032 - 0.072$

Structural and Local Vibrations Damping - When the structure is deformed by excitation, a significant part of the energy is dissipated through the joints and structural members, whether rigidly or non-rigidly connected. The physical

phenomenon of energy dissipation is not well understood, and it is not surprising that until recently there have been no attempts to solve this problem analytically. Recent studies, reviewed in Reference 19, indicate that joint damping is the major source of inherent damping, and several sophisticated models of damping and force transfer functions have been developed. A simple model of joints based on the equivalent linearization of some nonlinear features and empirical data has been proposed in Reference 48. A linearized approach, suitable for the macro-slip regime, is not sufficiently accurate for a system with many joints. The joint damping modeling for such multijoint system should include elastic and plastic deformation, and both micro-slip and macro-slip.

2.4 Ship Vibration Prediction Methods and Effects of Damping

Judgement of the adequacy of vibration characteristics of a design is typically based on the evaluation of the vibratory characteristics of the ship against specifications or established criteria. The adequacy of the prediction procedure is based on the ability to reliably measure the observed vibratory characteristics. Traditionally, ship vibration analysis is subdivided into various groups depending on the mode, on the problem encountered or on the frequency. Very often these groups are interchanged, because only coupled vibration can occur. However, for engineering purposes the total ship system is commonly subdivided into the following groups:

- Vibration of Hull Girder
- Vibration of Major Substructures
- Vibration of Propulsion Systems
- Local Vibrations

Special vibration analysis techniques have been developed for each of the above sub-problems. In developing a vibration damping program for wide application, the successive stages of the ship design process should be recognized. At the initial concept or preliminary design stages, only the approximate characteristics of the hull and propulsion system have been identified and the first level of analytical vibration prediction methods are employed. During succeeding design stages reflecting the iterative nature of the design process, the influence of variations in hull geometry, propulsion and control systems is examined, with the objective of optimizing the overall design. More advanced numerical and analytical vibration analysis methods are appropriate as the design progresses to the more detailed later stages.

Vibration predictions should be performed at all levels of design, and, therefore, correct identification of the damping characteristics is a critical factor in any vibration estimate.

2.4.1 Early Stage Design - The vibration of the hull and main propulsion system should be examined during the preliminary design level. This phase generally includes estimates of the principal vertical and torsional modes of hull and propulsion system vibrations. Since many of the calculations performed in the preliminary design phase may be based on assumptions and estimates, detailed design studies will be required in the later design stages. When the structural details are established, the vibration assessment of major substructures and local structural elements can be carried out. A typical vibration prediction procedure consists of the following steps:

- Selection or development of suitable equations of the math model of the mass-elastic system under consideration.

- Input or forcing functions determined theoretically or on the basis of systematic analysis of representative test data.
- Determination of appropriate damping coefficients.
- Assumption of appropriate procedures to simplify the analyses or to compensate for weakness of some aspects of the theory.

Damping plays an important role in ship vibration prediction since the resonant amplitudes of ship structural systems depend on the magnitude and location of the exciting forces as well as the magnitude of the damping representing the ship and surrounding water. The International Ship Structures Congress, Reference 8, had concluded that "general experience is that the accuracy in calculating resonant frequencies is high but the accuracy of the calculated force response is considerably less; the main cause is to be sought in modeling, insufficient knowledge of the amount of damping and the coupling at the boundaries".

2.4.2 Available Mathematical Models - The mathematical models used in the prediction of hull response are generally based on the availability of the technical data required, the status of the design and cost, and time available. Recent advances in computer technology in handling large and complex structures, together with use of interactive pre- and post-processors, have resulted in wide usage of the finite element techniques for the prediction of ship hull response. However, these methods require structural details which are not normally available in the preliminary design phase. However, the significant time and cost requirements do not justify the

application of finite element methods for the preliminary design stages.

In practical engineering design and vibration predictions, modeling a ship as a nonuniform elastic beam appears to be adequate for preliminary design requirements. Variations of this concept, such as rigid hull, simple beam, and Timoshenko beam, have been described in the SSC Report 302, Reference 48, and in Reference 49. A typical approach, such as used by the U.S. Navy for many years, is based on Timoshenko's differential equation for the full lateral vibration of prismatic bars, and the differential equation for torsion. The ship is represented by a non-uniform, continuous beam with 20 stations, having the same mechanical and elastic properties as the ship. The ship's structural weight, machinery, cargo, and added mass representing entrained water are lumped at the half stations. These masses are connected by beam segments which possess the same elastic properties as the corresponding ship sections.

For beam-mode ship vibration analysis, the equations of motions can be expressed by one of the following systems:

1. One fourth order equation.
2. Two second order equations.
3. Four first order equations.

A detailed analysis of these formulations is given in Reference 11.

In view of the future planned damping experiments, a general matrix form perhaps is probably most suitable, Reference 11:

$$S' = KD + \bar{M}\ddot{S} + D\dot{S} + Q \quad [25]$$

where $S = w, \theta, M, V$ is the state variable vectors and define deflection, slope, bending moment, and shear responses of the hull, respectively

$$\dot{S} = \frac{\partial S}{\partial t}, \quad S' = \frac{\partial S}{\partial x}, \quad \ddot{S} = \frac{\partial^2 S}{\partial t^2}$$

K, M, D are the stiffness, mass, and damping matrices, respectively

Q is the excitation vector: $Q = \{0 \ 0 \ b(x,t) \ f(x,t)\}$

$b(x,t)$ is the moment load

$f(x,t)$ is the force load.

For problems in the frequency domain:

$$b(x,t) = b_C(x) \cos \Omega t + b_S(x) \sin \Omega t$$

$$f(x,t) = f_C(x) \cos \Omega t + f_S(x) \sin \Omega t$$

Ω is the excitation frequency.

The solution of the linear equation (25) is given in Reference 11.

From Reference 50, the following equation, based on a nonuniform free-free beam, can be used as a theoretical basis for the planned damping studies:

$$\begin{aligned}
 (1 + r_s \frac{\partial}{\partial t}) (EI \frac{\partial^2 w}{\partial t^2}) + m(x) \frac{\partial^2 w}{\partial t^2} + \frac{d}{dt} [(\mu - \frac{i}{\omega} \lambda) \frac{dw}{dt}] = \\
 = F(x) e^{i(\omega t + \theta)} \quad [26]
 \end{aligned}$$

Here $EI = EI(x)$ is the hull rigidity, $m(x)$ is the ship mass (including cargo) per unit length, $\mu(x)$ and $\lambda(x)$ are the hydrodynamic coefficients for added mass and damping per unit ship length, ω is the frequency of the exciting force, $F(X)$ is the complex amplitude of the exciting force, the operator d/dt is

$$\frac{d}{dt} = \frac{\partial}{\partial t} - u \frac{\partial}{\partial x} \quad [27]$$

and u is the ship speed. Equation [26] takes into consideration hydrodynamic damping due to the waves generated during ship vibration. Only the most essential factors should be considered in the equation of motion [26].

Analysis of the predictions based on a beam model with test data indicates that for the lowest vertical and horizontal-torsional vibration modes of the hull, single non-prismatic beam models of various complexities have been shown to be accurate enough for the preliminary design level, as shown in References 48 and 49. The accuracy for simple models depends on the ship type and deteriorates, as shear and warping distortions become significant.

At the early design stages simple empirical formulas particularly related to damping for the lowest hull modes may be very useful:

Damping factor, C/C_0 is the reciprocal of the resonant magnification factor, Q , i.e.

$$Q = \frac{1}{2} C_c / C \quad [28]$$

The L. Taylor empirical formula for magnification factor, derived primarily for riveted vessels:

$$Q = 10000/N \quad [29]$$

where N = frequency of vibration in RPM, has been modified to include welded vessels:

$$Q = 56200/N^{1.45} \quad [30]$$

The above expression can be used for vertical, horizontal, and torsional vibrations.

For two-node vertical vibrations Kumai proposed

$$Q_2 = (0.75 + 1.0)L \quad [31]$$

and for higher modes ($n > 2$)

$$Q_n = Q_2 (N_2/N_n)^{0.75} \quad [31a]$$

More complete damping relationships for each mode, taking into account a variation of ship type and geometry, may be developed. For instance, a two-mode frequency formula based on analysis of 252 ships has been suggested in Reference 54. Results of the study in Ref. 55, shown on Figure 7, are well described by the expression:

$$\omega_1 = 218,000 I^{1/2} \left\{ \Delta L^3 \left(1 + \frac{B}{2T} \right) \left[1 + 21.5032 \left(\frac{B}{D} - 0.275 \right) \left(\frac{D}{L} \right)^2 \right] \right\}^{-1/2} \quad [32]$$

where I = moment of inertia of the ship in ft^4

Δ = displacement, long tons

L = LBP, feet

B = breadth, feet

D = depth, feet

T = draft, feet

ω_1 = two-node frequency

It may be appropriate to explore development of similar general formulations for damping coefficients.

2.4.3 Structural Analysis Software for Ship Vibration Predictions - Although the simple beam theory is a useful guide in the preliminary design stages, the detail structural design of most large ships is now based on finite element methods (FEM). Since its introduction for ship structural problems around 1965/66, FEM has been established as a universal tool, particularly in linear strength analysis. Most investigations are either totally based on finite element calculations or use FEM for comparing experimental data or other analytical calculations. The major advantages of FEM applications are:

- Comprehensive overall strength or specific vibration analysis of the entire hull or its major structural components. A typical example of the FEM model for the ship structure analysis is shown on Figure 8, taken from Reference 8.

- Better use of materials and design strategy and effective solution of specific problems such as coupling of the main structure and main propulsion shafting system; local vibration of the major bulkheads, deck platings and openings; support structure for the major machiner, etc.

- Accurate hull structure response predictions in time/frequency domain under a variety of loads (waves, propeller pressure, random loads).

With widespread use of pre- and post-processors, Reference 56 and 57, and other new computer hardware, it is now possible to make elaborate overall analysis of the ship strength and its vibrational characteristics in a fraction of the time required a few years ago. Reference 8 contains a detailed survey of linear and nonlinear FEM software available worldwide. Today linear elastic FEM analysis appears to be almost a standard engineering procedure. With regard to the proposed damping evaluation program, it is imperative to conduct correlation between analytical and experimental results on the basis of the standard FEM numerical methods. The SSC Report 302, Reference 48, contains extensive information on many general-purpose and specialized FEM analysis programs. Update of the FEM capabilities and analysis of adaptability of pre- and post-processing software to a wide range of computer hardware is included in Reference 8.

Although the FEM is most often used in vibration analysis, the boundary element method (BEM) seems to be promising. The essential difference is that this method defines a reduction technique based on integral equations that are satisfied on boundaries. This method has been effectively used for calculation of the added masses. In structural analysis the method is still not commonly used but it is sufficiently promising to deserve further attention, see Reference 8.

Regardless of the numerical technique (FEM or BEM) used, the dynamic vibration analysis of the hull or any elastic linear ship structure generally consists of two steps:

(a) Prediction of vibration modes on the basis of stiffness and mass characteristics information, because damping typically has a small effect on mode predictions.

(b) Prediction of the response of the system to a given excitation using mode superposition procedures and requiring a knowledge of the exciting forces as well as of the damping characteristics of the system.

After completing these steps, the values of maximum displacement and/or accelerations at the desirable point of the structure under the loads, or assumed service condition, are established. Thus, no matter how accurate the FEM method is, the precision of knowing the excitation behavior of ship systems in the service environment or during the excitation tests is determined in large degree by the damping characteristics of the system. On the other hand, FEM provides a basis for the modal damping identification by the System Identification Method, i.e., for a given excitation and measured system response a modal damping is determined by one of the optimization procedures for a "best fit" of measured data to the assumed analytical and numerical model.

There are serious criticisms of the above procedure: Although the subject of damping cannot be identified until it is described mathematically, a value defined by the above procedure is not the true damping but the average of "apparent" damping which is the overall effect of several factors:

- Assumptions of the linear theory
- Limitations of the response measurements
- Limitations to consider additional effects not accounted for by analytical or test procedures.

For example, only recently, due to the improvement in test analysis techniques for full-scale vibration measurements, it has been established that vibration amplitude at resonance is related not only to the damping but is also dependent on the rate and magnitude of engine speed variation. The effect is quite significant for ships having inherently low damping and it has been speculated that some design data produced in the past may have been misleading.

In the discussion in Reference 8, it is noted that the manner in which the excitation and energy is carried by wave motion, slamming or green seas (so-called ambient excitation), may differ considerably from the test excitations.

In the framework of the proposed program, it will be impractical and may be unnecessary to extend model experiments or theoretical work to investigate these effects in detail. Without knowledge of their existence and some quantitative appreciation of their significance, any attempt to relate the theoretical and model experiments to the behavior of full scale ships may be frustrated, and estimated damping results might be of little practical value.

2.4.4 Non-Linear Structural Analysis - Non-linear finite-element methods have recently been introduced to the ship design process and to recent designs of offshore platforms. The major differences between linear and non-linear structural behavior is that in the non-linear case the principle of superposition does not apply and the response of the structure frequently depends on the total loading history, i.e., "memory effect". Convenient conceptions of the added mass and damping coefficients can no longer be applied, as damping becomes not only a function of the response amplitude but of time as well.

Nonlinearity with regard to geometry and amplitude of motions and time dependency introduce additional elements of uncertainty and difficulty in identification of damping from test results.

There are a large number of nonlinear structural analysis program including many general-purpose nonlinear FEM programs. There are also several hundred specialized and research-oriented programs in existence, see Reference 8. Several companies have developed proprietary nonlinear FEM programs, such as the program FACTS (SSD, Inc., California), USAS (American Bureau of Shipping) and EPSA (Weidlinger Associates, New York). Reference 56 provides an extensive survey and table comparing the formulations and various available options of many nonlinear FEM programs. Regarding the analytical simulation of the dynamic behavior of the structure under impact loads, several special-purpose computer program, e.g., DYNA3D (Lawrence Livermore National Laboratory), PISCES, IMPACT-1, STEALTH, and HONDO are known. However, this type of analysis requires appropriate time-stepping strategies and involves geometric and material non-linearities. Verification tests of the numerical behavior predicted by these programs are necessary to insure their accuracy.

In numerical treatment by the non-linear FEM programs, loading has to be applied in small load increments, with equilibrium equations imposed at each step. Because the stiffness of the structure now depends on deflection, a simple inversion of the stiffness matrix does not automatically lead to satisfaction of the equations of equilibrium and an iterative process must be applied. Clearly, these factors compound to increase the computational effort required in nonlinear analysis, which usually exceeds that of the linear

case by several orders of magnitude. Considering these and other difficulties in nonlinear FEM, such as solution errors and convergence examination, the non-linear FEM numerical analysis may not be appropriate for purpose of correlation of theoretical and experimental results. However, serious attention to possible non-linear and non-stationary effects should be given and, possibly, identified. This approach could provide enormous help in further reanalysis of these data, perhaps on the basis of a more accurate and complete theoretical model.

2.4.5 Fluid-Structure Interaction and Hydrodynamic Damping - The hydrodynamic component of vibration damping is associated with energy losses at the fluid-structure boundaries. These losses are of a viscous and pressure field nature, if the assumption of their weak interaction is valid. In fluid dynamics problems, viscous and pressure forces are independent for most engineering problems. Viscous forces occur in the friction stresses along the hull, and vorticity formation primarily at the ship stern, and propeller viscous wake behind the ship. While important for ship resistance and ship performance problems, these forces presumably contribute very little to damping associated with ship vibration phenomenon, particularly to the first eigen modes. This situation differs for high frequency vibrations because the viscous component is the only remaining non-zero hydrodynamic component left. The theoretical basis describing turbulent viscous flow exist in a set of Navier-Stokes equations for "average" and "turbulent" flows. However, the numerical attempts to solve these equations even for simple problems are beyond the capability of the most powerful computer systems in existence. An excellent state-of-the-art review of this subject is given in Reference 58.

For engineering purposes, however, there are several formulations which will allow approximate estimation of ship frictional damping, assuming the ship surface to be equivalent to the flat plate of the same area as the ship wetted surface. This is a generally accepted assumption in ship resistance analysis.

2.4.6 Propeller Induced Hydrodynamic Forces - Propeller-induced hull vibrations and related hydrodynamic phenomena have been the subject of intensive theoretical and experimental studies during the past 20 years and a survey of the progress in this field is beyond the scope of this report. References 59 and 8 include a comprehensive review of this information including both, theoretical and experimental studies.

Several aspects of this problem with respect to vibration damping measurements and further correlation of the test data with the predicted results are considered here. Two categories of propeller induced forces result from propeller rotation in the viscous wake behind the hull. The first includes the shaft forces due to the propeller operation in a non-homogeneous wake field. Shaft forces are generally predictable by theoretical and semi-empirical methods. Results of comparisons with ship-board measurements are given in Reference 8.

The second category of propeller exciting forces is due to the pressure induced by the propeller on the hull surface. There are many methods available for estimating these pressures and resulting forces for non-cavitating propellers. For commercial vessels, it has been established however, that the main source of vibration excitation results from the cavities on the propeller blades. Cavities on the blade can release substantial amounts of energy producing almost instantaneous

pressure pulses on the hull (often called a free space pressure). Much effort is being directed to the determination of the fluctuating pressure field induced by the propeller and cavities. Typically, this is achieved by theoretical or partly experimental means using test measurement in a cavitation tunnel.

Once a pressure component of K_{th} mode, p_K , is established the "generalized excitation force," F_K , can be estimated by the integral over the ship wetted surface, Ω , Reference 59:

$$F_K = \int_{\Omega} P_K S_K f_K d\Omega \quad [32]$$

where f_K is a weighting function identifying "generalized" forces for various vibration modes of the hull, and S_K is the so-called solid boundary factor, i.e., the factor converting the pressure, calculated for the free field, to the pressure at the stern of the ship. Values of this factor and methods of determining it are discussed in Reference 8. From Figure 9 taken from Reference 59, it is evident that values of this factor can only be a fraction of the commonly used theoretical value of 2 for points distant from the propeller and/or close to the free surface. The value 2 strictly applies only to a flat plate of infinite breadth and width in an infinite fluid. Comparisons with earlier investigations indicate that the main cause for the low values shown in Figure 9 is the presence of a free surface rather than the curvature of the hull surface.

This conclusion is important for estimating hydrodynamic components of vibration damping, because wave energy from the propeller dissipated on the free surface should be accounted for in the overall balance together with wave-making damping by

the ship hull. If an analytical and numerical solution of the hull/propeller wave problem is obtained, by such means as distributing the singularities (sources, sinks, and dipoles) along the rigid boundaries, the solution will give the "added mass" inertia forces as in-phase components, and damping forces as out-of-phase force terms. Damping forces due to the propeller could be measured in a special design test by a phase variation method by measuring, or estimating the value of propeller excitation and the phase angle between excitation and response.

It should be emphasized that no source has been found in the literature dealing with damping evaluation of the viscous and propeller operation losses in regard to ship vibration analysis. In the discussion of the propeller excitation subject at the 9th ISSC, Reference 8, it was concluded that "... the painstaking accuracy and large efforts devoted to the problem of dealing with influence of cavitation seem somewhat opposed to the ease which potential flow is assumed and the influence of viscosity is neglected. It is recommended that a shear flow theory is developed in order to reach a more balanced and adequate distribution of attention to the different aspects of the problem." The majority of existing engineering vibration codes today assume that the effects due to structural damping, cargo damping, water friction and pressure waves due to the propeller can be lumped together under the name of "internal" damping, as discussed in Reference 60. The term "hydrodynamic" damping is related to the wave effects due to the vibration and forward movement of the vessel. Reference 61 includes a graphical presentation of the "internal" damping with frequency based on experimental data for all-welded ships. Figure 10 taken from Reference 8 shows the relationship between the resonant frequency and different

sources of vibration. Within the frequency range of interest for ship vibrations, the "internal" damping increases with frequency in a logarithmic relation. Hydrodynamic damping, however, after a sharp increase from zero to a maximum value at low frequency, gradually decreases and becomes very small at non-dimensional frequencies, $\omega_n = \omega \sqrt{L/g'} > 10$. See representative results in Figures 12 and 14. Thus, at propeller blade frequencies, and higher, the hydrodynamic damping is very small compared to the internal damping and can be neglected. Around the frequencies of the hull girder lower modes, the hydrodynamic damping is quite significant.

2.4.7 Hydrodynamic Damping Due to Oscillation and Forward Motion - Hydrodynamic damping is the most investigated component of fluid induced damping by both theoretical and experimental methods. The main source of energy loss in this case is a surface wave formation which is almost independent of viscous properties of the fluid. Well-established potential theory methods, e.g., singularities distribution, Green's functions, etc., combined with effective numerical procedures to calculate fluid-induced pressures and forces as functions of frequency and forward speed, are applicable. The pioneering 1946 Haskind study on ship behavior in waves was largely unknown in the West until rediscovered by Newman and further developed in the early 1960's. The earlier formulation of the strip theory based on the assumption of slow variation of the hydrodynamic loads along a conventional ship hull was originally formulated by Korvin-Kroukovsky, and later modified by Gerritsma, Tasai, Faltinen, Salvesen, Tuck, and Ogilvie. Numerous comparisons of predictions with experiments confirmed the basic validity of strip theory formulations. Figures 11 through 14, taken from Reference 62 show typical results for added masses and damping coefficients representing the first

and second mode shapes, e.g. for heave and pitch motions respectively. The next, third mode to a two-node deflected shape is called the "springing" mode representing the fundamental or lowest mode deflection of a free-free beam. In ship vibration, however, this third mode is sometimes referred to as the first or fundamental mode of vertical vibration. This mode is of particular interest for wave-induced "springing" studies.

The results are shown for Todd's Series 60 ships with block coefficient, $C_B = 0.70$ and various length/beam ratios. "Old" theory, on this figure refers to Korvin-Kroukouvsky's theory, and the "new" theory is in accordance with Reference 63 which defines the sectional hydrodynamic forces, $F'(x,t)$ by the following expression in complex variables:

$$F'(x,t) = - \frac{D}{Dt} \left[(m_a' - \frac{i}{w} N_a') \frac{D}{Dt} (z') \right] \quad [33]$$

Where

$$\frac{D}{Dt} = \frac{\partial}{\partial t} - u \frac{\partial}{\partial x} \quad , \quad i = \sqrt{-1} \quad ,$$

and

m_a' is the sectional added mass

N_a' is the sectional damping coefficient

u is the forward speed, w is the oscillation (vibration) frequency,

z' is $z_g - x\theta$, is the sectional vertical speed determined as a difference of ship heave, z_g , and vertical distance of a section due to the pitch, $x\theta$.

Integrating [33] along the hull and taking only the real part, the inertia and damping forces are defined.

It is obvious that added masses are predicted by the strip theory with good accuracy for a wide range of frequencies. For very low frequencies which are not particularly important for vibrations both added mass and damping are poorly described by this theory. The damping coefficient values are in satisfactory agreement with measurements for moderate frequencies. At higher frequencies ($\omega\sqrt{L/g} > 10$) wave damping becomes very small and viscous damping plays an increasing role. In regard to flexible vessels, Suhir, Reference 64, has proposed the following formula for damping coefficients:

$$\zeta = \frac{1}{2M} \left[\int_L N'(x) X^2(x) dx + \frac{u^2}{w^2} \int_L N'(x) \left[\frac{dX}{dx} \right]^2 dx \right] \quad [34]$$

where $X(x)$ is a mode vibration, M is a sum of ship mass and added mass, and integration is performed over the ship length, L . Somewhat similar to the Equations [33] and [34] formulations have been proposed in References 65 and 66. In Reference 66 it was demonstrated that the use of a two-dimensional added mass distribution, multiplied by a J -factor derived for a vibrating ellipsoid, provides a remarkably good agreement with a complete three-dimensional solution. It appears that the inertia forces along the ship hull in Timoshenko beam equations can be effectively estimated using J -factors for ellipsoids or Lewis forms. Effects of forward speed on the stripwise predictions are still under consideration. For instance, an alternative to Equation [33], without complex variables:

$$F'(x,t) = - \frac{D}{Dt} m_a' \left[\frac{D}{Dt} (z') \right] - \frac{D}{Dt} [(N'z')] \quad [33a]$$

gives different force distribution and overall results than Equation [33]. Equation [33a] appears to be more accurate from the physical point of view. But Equation [33] in fact, is

actually more accurate from the mathematical point of view. Recently, another alternative form of the stripwise equations of motions was introduced in References 67 and 68, which describe the hydrodynamic loads and forces in a coordinate system rigidly attached to the vessel, i.e., as in "stability" axes, typically used in submarine studies. Convenience and justification of the last coordinate system lies in the fact that the ship geometry, and in fact, hydrodynamic pressures, can be described correctly only by this system. The equations of motion become very simple. In regard to structural analysis, this approach might have definite advantages, particularly in comparing the predicted and experimental data. Measurements on the vessel, such as stresses can be related only to the stability axes. For instance, in this coordinate system the questionable second term in Equation [34], which gives infinite results for small and zero frequencies, will disappear. Lastly, ship flexibility can be introduced in terms of the stripwise approach suggested in Reference 55. The additional terms are connected with the forward speed value and contribute to the ship damping and stiffness effects.

The so-called "unified theory", originated in 1982 by N. Newman, was an attempt to overcome difficulties of the strip theory in the low small frequency range. However, recently it has been recognized that this theory has no specific advantages over the strip theory, and, in fact, introduces its own problems. This suggests that procedures commonly called "strip" methods are still of considerable practical importance. Among the methods that may still be classified as "strip theories", but for which some particular advantage is claimed, Reference 65 is cited where ratios of 3-D damping to 2-D strip theory damping for heave and pitch are derived and used as correction factors.

The alternative to the traditional "strip" or slender body theories is the fully 3-D motion formulation which was initiated by M. Chang, Reference 70, and further elaborated by Inglis and Price in Reference 71. Figure 15, taken from Reference 70, shows a comparison of the different prediction methods with the experimental data. Zero-speed 3-D predictions are in excellent agreement with the experiments, but for a ship with forward speed, viscosity becomes important. Corrections of 3-D nonviscous predictions on viscous effects by methods described in Reference 68, improve the agreement of 3-D method predictions with experiments for a vibrating and constant speed ship.

Promising results on solution to similar problems have been reported by Beck and Lapis of the University of Michigan at the Numerical Hydrodynamic Symposium held in Washington, D.C. in 1985. Their formulations and solutions of the linear wave-induced problem are first obtained in the time domain and then converted to the frequency domain by the FFT numerical code. Summarizing the 3-D approach the following conclusions can be drawn:

(a) If the linear inter-dependence of ship motions and disturbances is valid, these methods are applicable for describing hull/fluid dynamics for practically any ship hull configuration. Some FEM methods are actually capable of solving both, structural and hydrodynamic problems, as shown in Table 4.

(b) Most available 3-D solutions are valid for the zero forward speed case only. The axial velocity makes the potential solutions more difficult and adds another complication associated with the viscous effects, which become

significant in the high frequency range. There is no simple methodology to account for 3-D viscous effects. The high frequency range also presents particular numerical difficulties for potential solutions.

(c) Despite their apparent generality, the linear 3-D approaches do not properly satisfy governing boundary conditions at the intersection of the ship hull and free surface, particularly for flexible ship hulls. Unless a straightforward nonlinear time-dependent numerical approach is applied, some linearization of the boundary condition is required. Hydroelastic behavior of the marine structures including the influence of forward speed, free surface, and the flexibility of the structure is discussed by W. G. Price and Y. Wu in Reference 75.

(d) In principle, 3-D methods can provide a distribution of the hydrodynamic forces along the ship hull, but no numerical results have been found in the literature. This may be because dynamic damping distribution is required in order to know structural damping along the hull.

It can be concluded that for each level of vibrational and structural analysis, the appropriate level of the hydrodynamic formulations and solutions can be found, starting with beamlike approaches to the comprehensive 3-D solutions compatible with an elaborate structural description. However, the available numerical results are limited, and hydrodynamic damping is still poorly understood in regard to frequency and speed dependence.

Designers require guidance on specific advantages and restrictions of the stripwise methods versus more comprehensive

but costly 3-D approaches. At resonance conditions, another difficulty may arise. Resonance may amplify the effects of certain forces which would otherwise be unimportant, requiring that they be included in the vibration analysis if a true representation of the loads and responses is to be obtained.

2.4.8 Non-Linear Fluid Dynamic Formulations - In recent years, there have been attempts to consider some non-linear factors in the hope that such partial non-linear solutions make predictions closer to experiments. An engineering approach based on the modifications of the standard strip theory, by assuming that all hydrodynamic forces vary as a function of instantaneous draft, is developed in Reference 70. Jensen and Pedersen evaluated the sectional hydrodynamic force, $F'(x,t)$ (see Equation [33]) by a perturbational method, taking into account linear and quadratic terms in the relative displacement, $z(x,t) = w(x,t) - \zeta_w(x,t)$, and thereby in the local displacement of the hull girder, w , and local wave surface elevation, ζ_w . They used the following approximations for the added mass and damping coefficient:

$$m_a(x,z) = m_a(x,0) + z \left(\frac{\partial m_a}{\partial z} \right) + O(z^2)$$

$$N(x,z) = N(x,0) + z \left(\frac{\partial N}{\partial z} \right) + O(z^2) \quad [35]$$

and found better agreement with the experimental results than by using the ordinary strip theory formulations. The subject of the non-linearity in the model and full-scale experiments for vibration damping should be evaluated very carefully, and the tested methodology and analytical procedures generally based on a strictly linear approach should be extended to examine the important non-linear damping factors. In

non-linear systems, the standard definition of damping may not apply because additional quadratic terms originating from the inertia properties of the fluid will actually act as damping forces connected with the square of hull girder displacements. For instance, assuming that the local added masses and damping in [33] also vary in the vertical direction, [33] yields:

$$F'(m,t) = -m_a' \ddot{z}' - N' \dot{z}' - \frac{\partial m_a'}{\partial z} \dot{z}'^2 + \frac{\partial N'}{\partial z} z' \dot{z}' + u \frac{\partial}{\partial x} [(m_a' - \frac{i}{w} N') \frac{D}{Dt} (z')] \quad [36]$$

The additional non-linear terms in the brackets are due to the variation of the sectional forces in the vertical direction and should be added to the damping components. The first term, $\partial m_a' / \partial z \dot{z}'^2$, is very much the same as the term describing non-linear forces associated with large motions and slammings. P. Y. Chang in his effort to incorporate additional non-linear effects in the NSRDC developed program ROSAS, Reference 71, suggested adding the following group of terms:

$$\Delta F'(x,t) = [u \frac{\partial m}{\partial x} \dot{z}' - z u m_a \frac{\partial \dot{z}'}{\partial x}] + [\mu w \frac{\partial^2 w}{\partial x^2}] \quad [37]$$

where w is the hull deflection. These terms account for variation of damping in the longitudinal direction. An integrated approach, in which non-linear "impact-type" force terms have been introduced into strip theory, is described in Reference 72. The authors show that whipping results are very sensitive to the structural damping assumption. It should be noted, however, that all of these models are actually extensions of the stripwise approach adopted to model some non-linear local responses.

Truly non-linear fluid/structure interactions can be only described by so-called "physical model" numerical codes. See References 41 to 45. There are a number of available numerical codes, such as MAS or SMAC, SOLA-VOF, the commercially developed by Hirt HYDR-3D computer package which can operate on VAX Computers. These numerical algorithms that solve viscous flow equations by the finite difference technique generally require a great deal of computer time. Despite these limitations, they do provide a valuable insight into flow/structure phenomena and have the following general features:

1. Generalized boundary and body shapes. Fluid boundaries and ship shapes are completely general.
2. Solution is fully non-linear. There are no linearizing assumptions which restrict either the free-surface motion or the ship motion to small amplitudes.
3. Solution is performed in the time domain.

Tracor Hydronautics has installed and verified the Inertial Marker Potential (IMP) method described in Reference 42 on a VAX 11/750 computer system. The IMP numerical code is based on the non-viscous time-dependent Euler's equation of the fluid with generalized fluid/hull boundary conditions. Modification of this code to include some viscous and rudder/propeller effects are under development under an ongoing study sponsored by the Maritime Administration.

Viscous-inviscid interaction can be incorporated in several alternative ways, and there is comprehensive information on this subject, especially from the studies in the aeronautical field. See, for instance, Reference 43.

During the last few years several alternative viscous models have been developed which possess the important elements of simulating viscous phenomena and do not suffer from low numerical efficiency. For instance, Figure 16 taken from Reference 44, shows the results of hydrodynamic studies for a large crude carrier sailing through a channel. The numerical model is based on a two-dimensional viscous flow field. The resulting pressure distribution is used to calculate all forces and squat of the vessel. The comparison between the calculated and experimental results is generally good.

In Reference 74, a new approach called "partitioned analysis procedure" for the analysis of coupled-field dynamic problems has been introduced. In this approach, field state vectors of the coupled equations are processed by separate program modules called field analyzers. The solution of the coupled system results from the execution of a set of analyzers synchronized to operate in sequential or parallel fashion. The analysis of a fluid-structure interaction problem, for example, may be obtained by a procedure which allows execution of separate fluid and structural analysis programs in strictly sequential fashion, and exchange of interface-state data, such as pressures and velocities, at each time step. The key advantages of this procedure appear to be significant computational efficiency and modular implementation.

Undoubtedly further developments in computer technology will bring these new flow/body numerical codes into design practice.

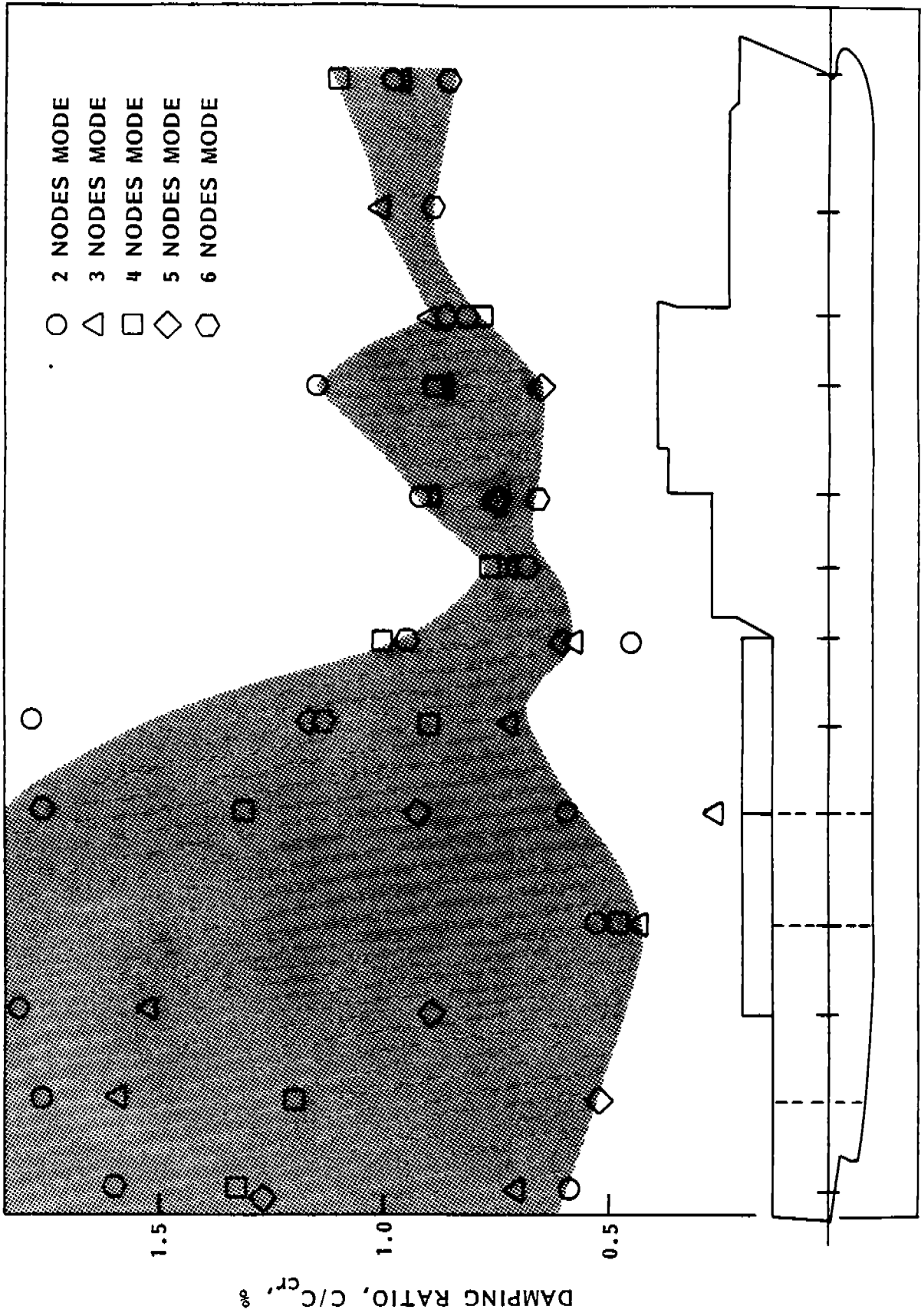
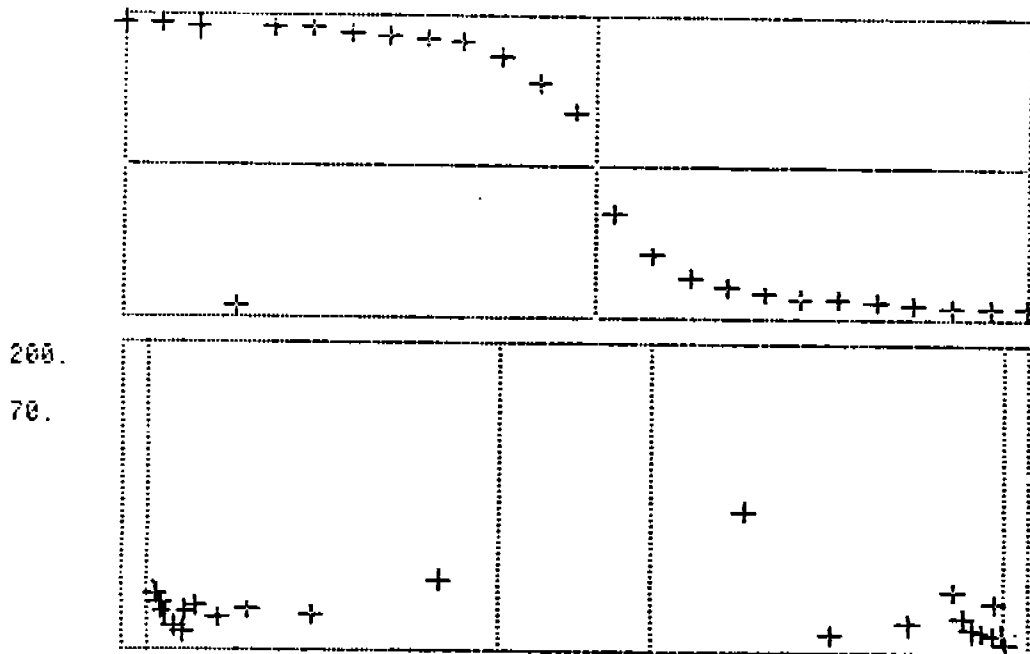
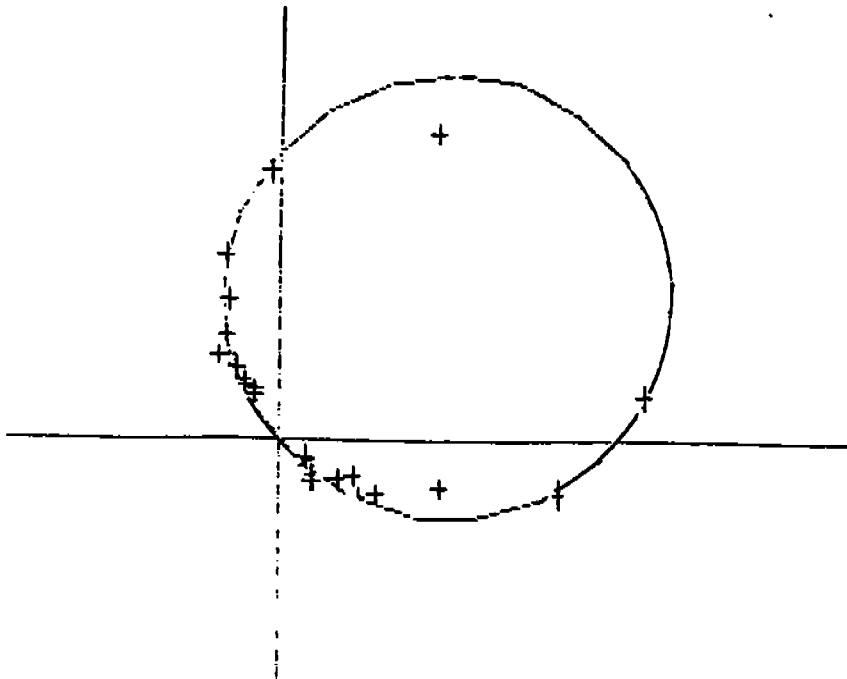

FIGURE 1 - VARIATION OF DAMPING COEFFICIENT ALONG THE SHIP FOR DIFFERENT VIBRATION MODES (REF. 12)

POLAR PLOT AND TEST DATA ARE SHOWN FOR A GENERAL CARGO SHIP



The natural frequency is 1.503

Mean Q within tolerance bands is 86.8

FIGURE 2 - TYPICAL VIBRATION TEST DATA ANALYSIS USING CIRCLE - FITTING PARAMETER METHOD

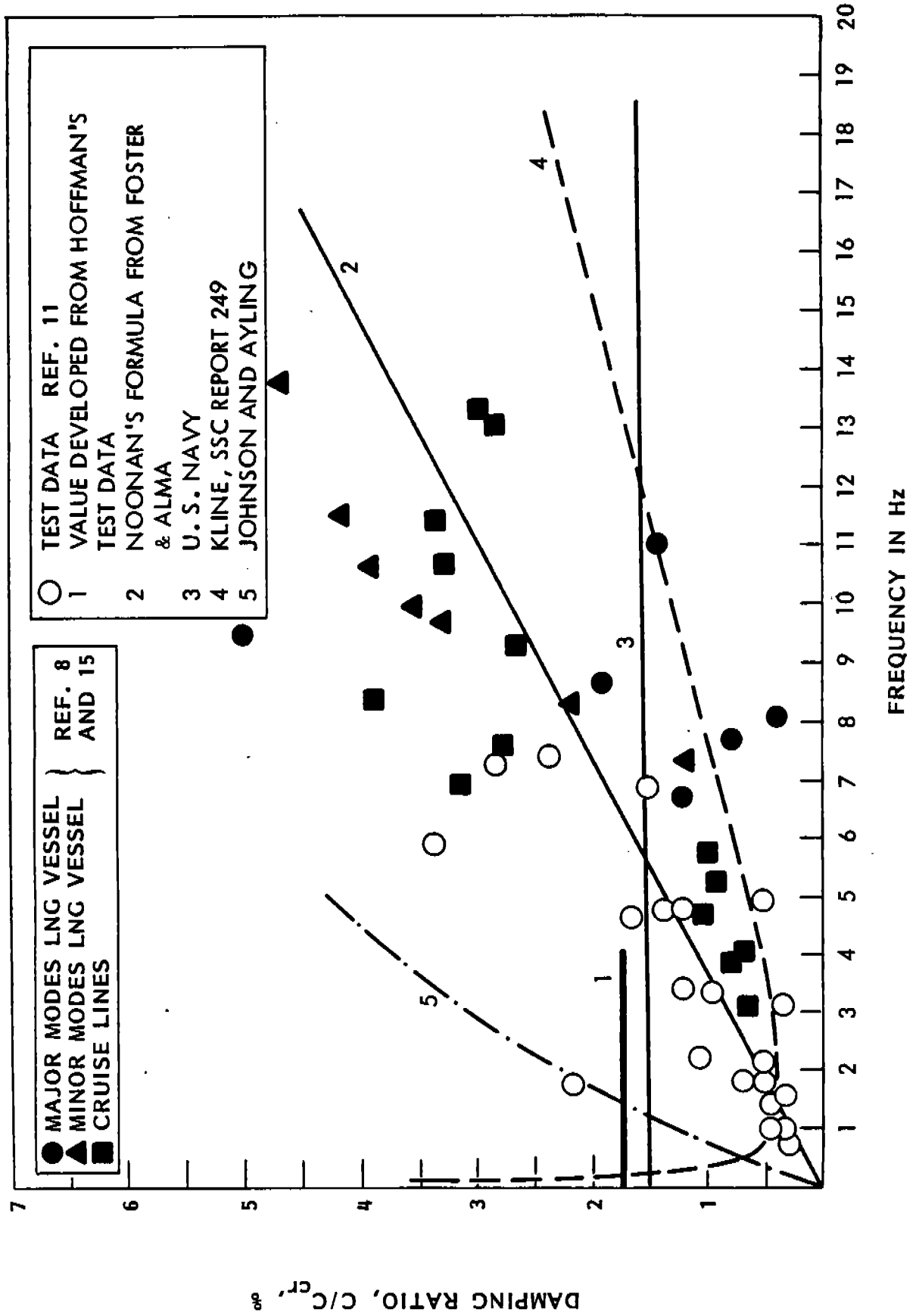

FIGURE 3 - DAMPING COEFFICIENTS DETERMINED BY VARIOUS INVESTIGATORS

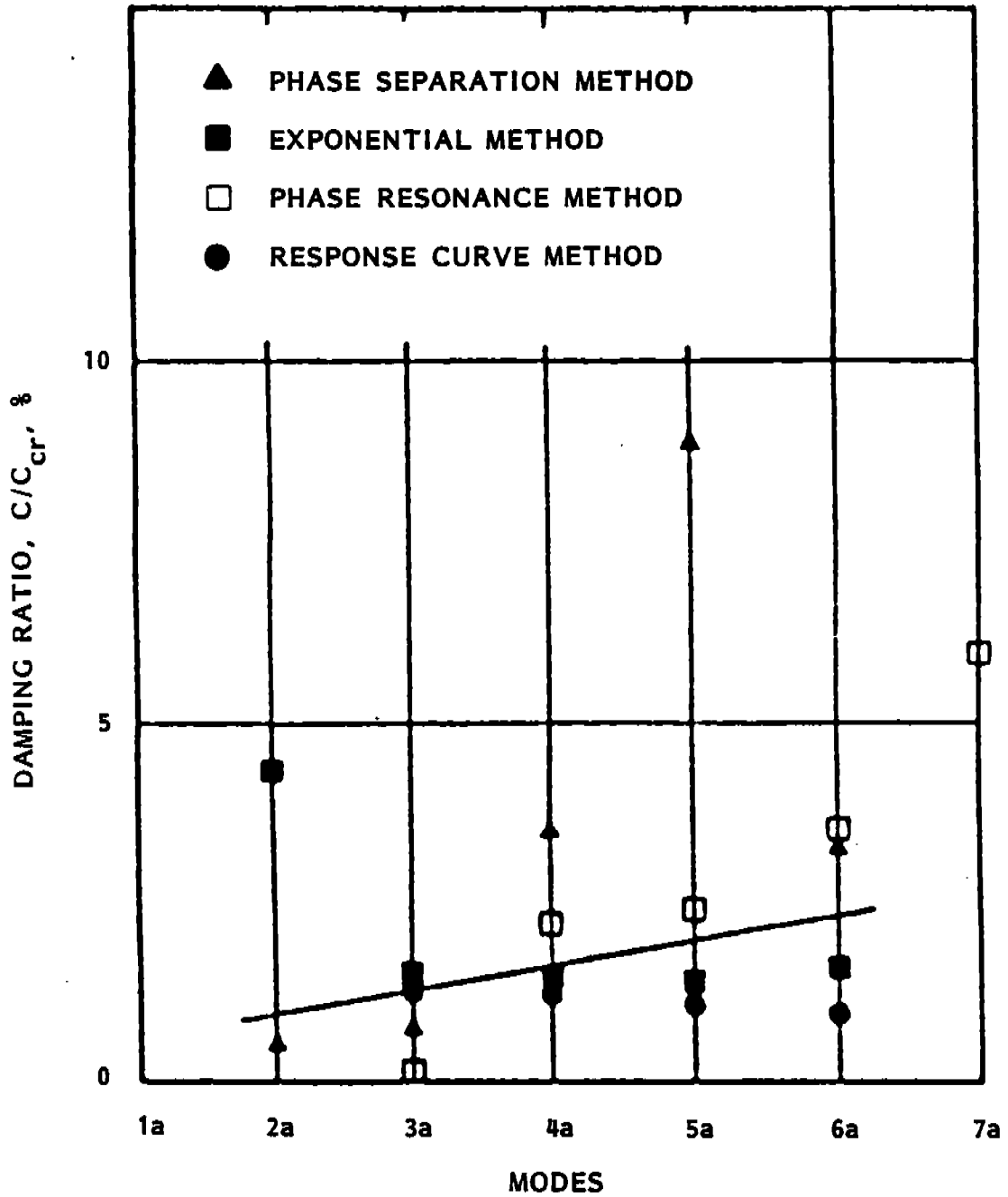

FIGURE 4 - DAMPING COEFFICIENT IDENTIFIED BY DIFFERENT ANALYSIS METHODS FOR A CAR FERRY (REF. 12)

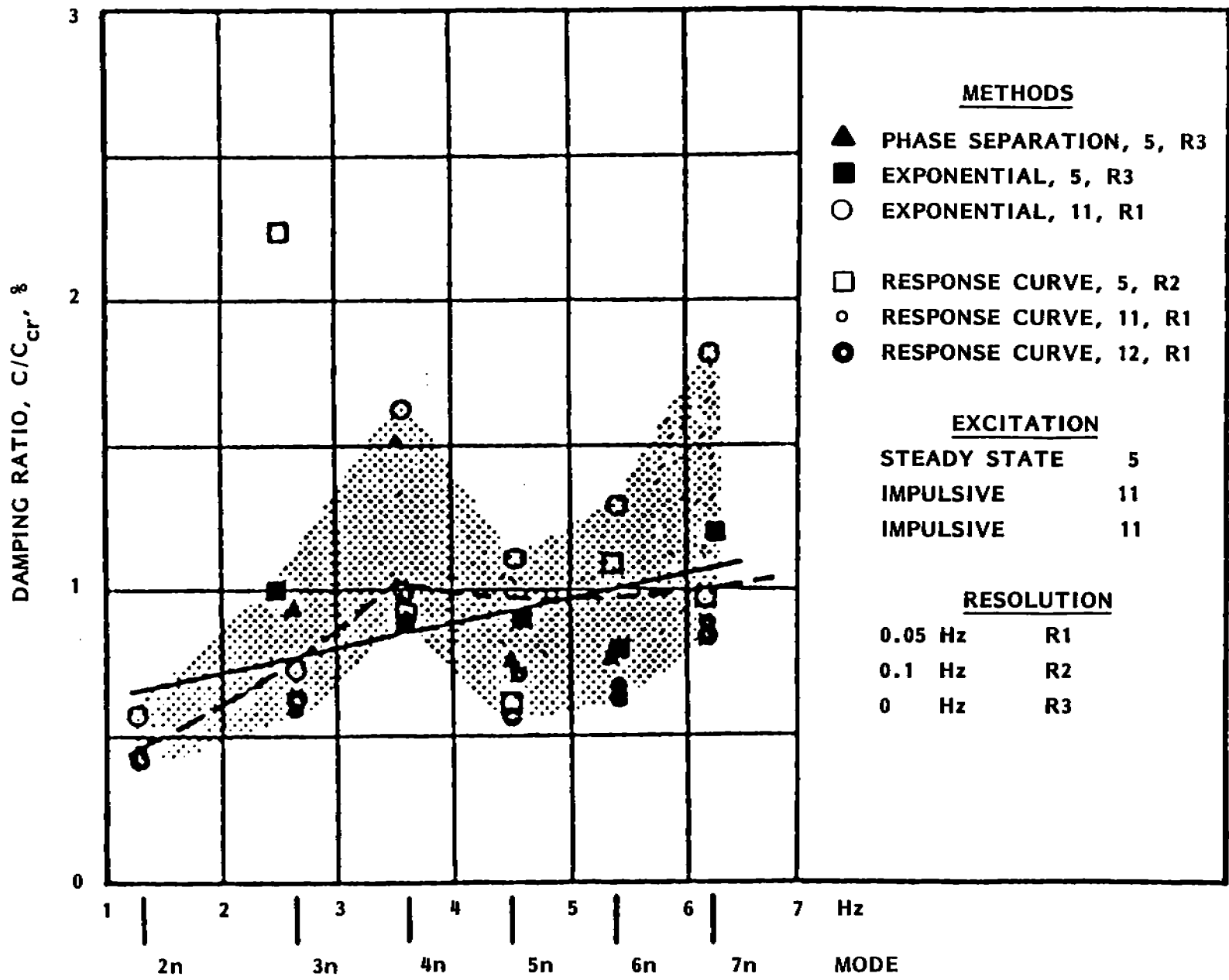

FIGURE 5 - COMPARISON OF DAMPING COEFFICIENTS DETERMINED BY STEADY STATE AND TRANSIENT (IMPULSIVE) EXCITATION (REF. 12)

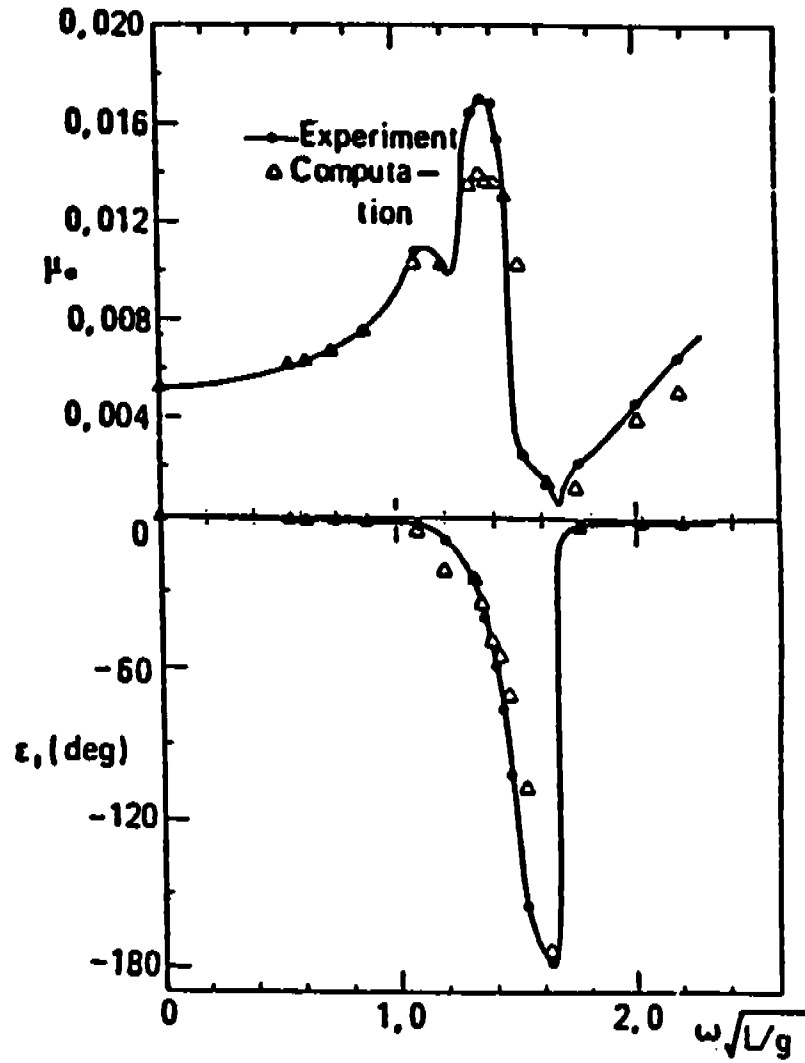

FIGURE 6 - EXPERIMENTAL AND COMPUTED DIMENSIONLESS AMPLITUDE AND PHASE ANGLE OF SLOSHING MOMENT, FROM REF. 40

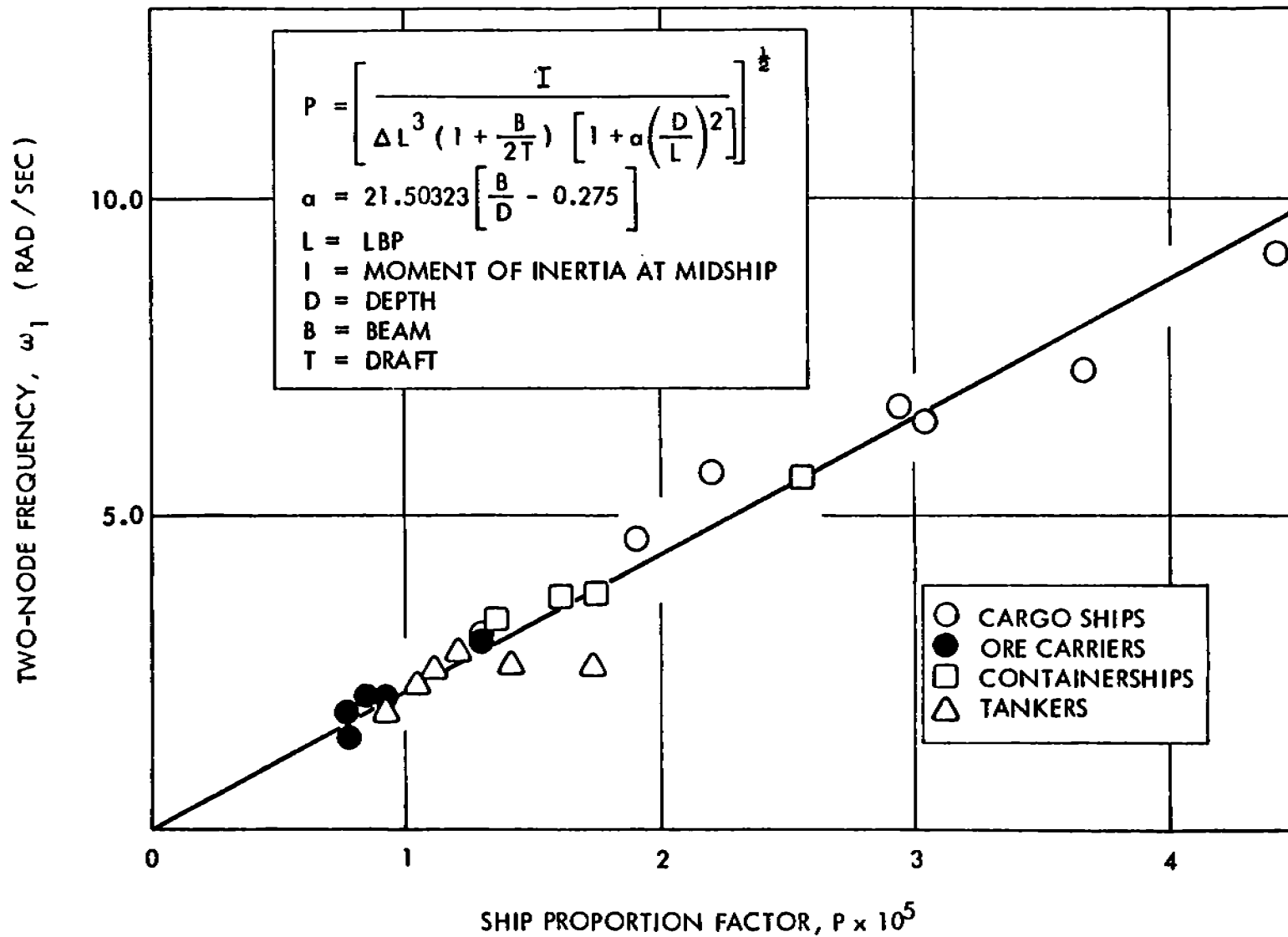
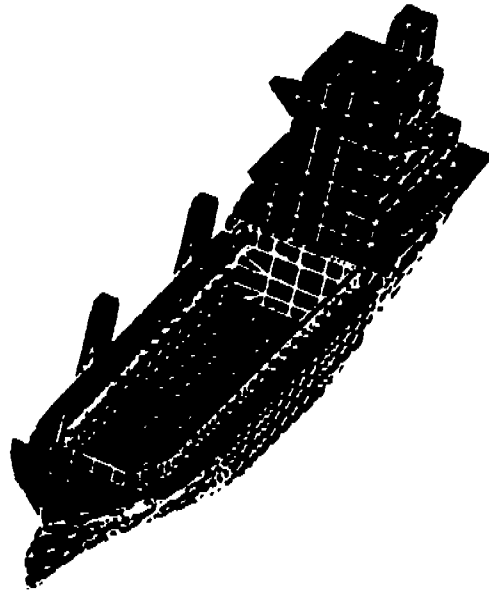
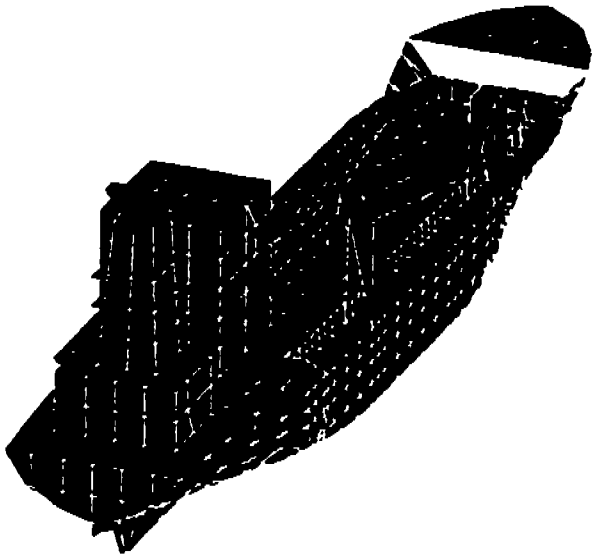

FIGURE 7 - EFFECT OF SHIP PROPORTIONS ON THE HULL FLEXIBILITY
 (REPRESENTED BY THE TWO-NODE FREQUENCY), FROM
 REF. 55

2-67



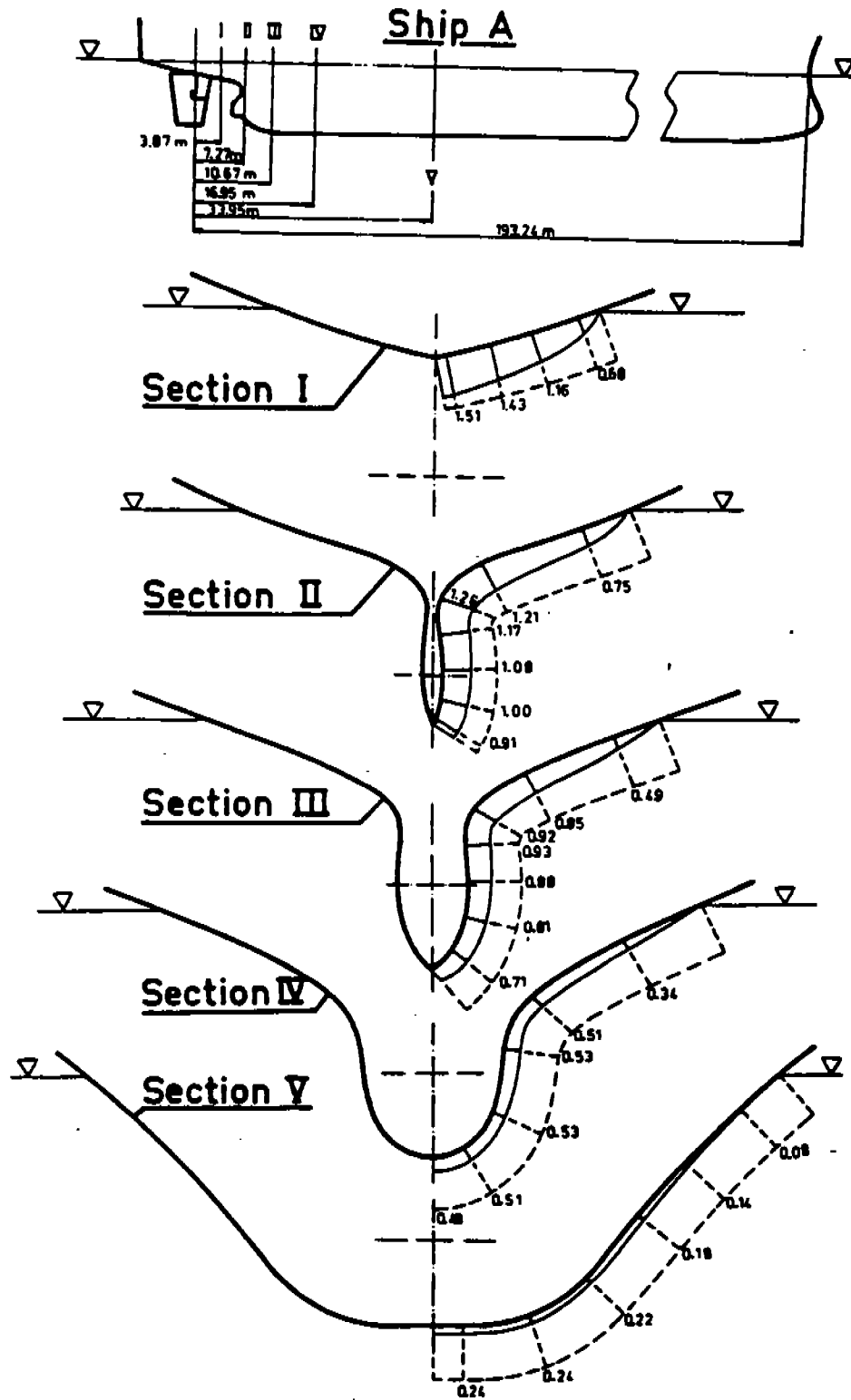

FIGURE 9 - EXAMPLE OF VARIATION OF SOLID BOUNDARY FACTORS, INCLUDING INFLUENCE FROM FREE SURFACE EFFECTS, REF. 59. DOTTED LINES REPRESENT THE VALUE $S = 2.0$

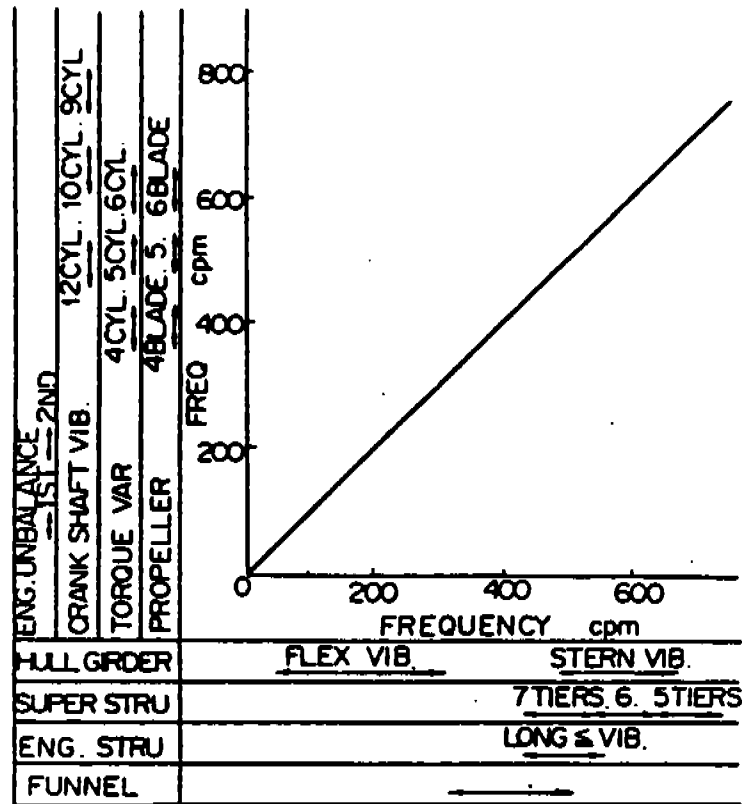

FIGURE 10 - RESONANT FREQUENCIES OF HULL STRUCTURE RELATED TO VIBRATION MODE AND EXCITATION

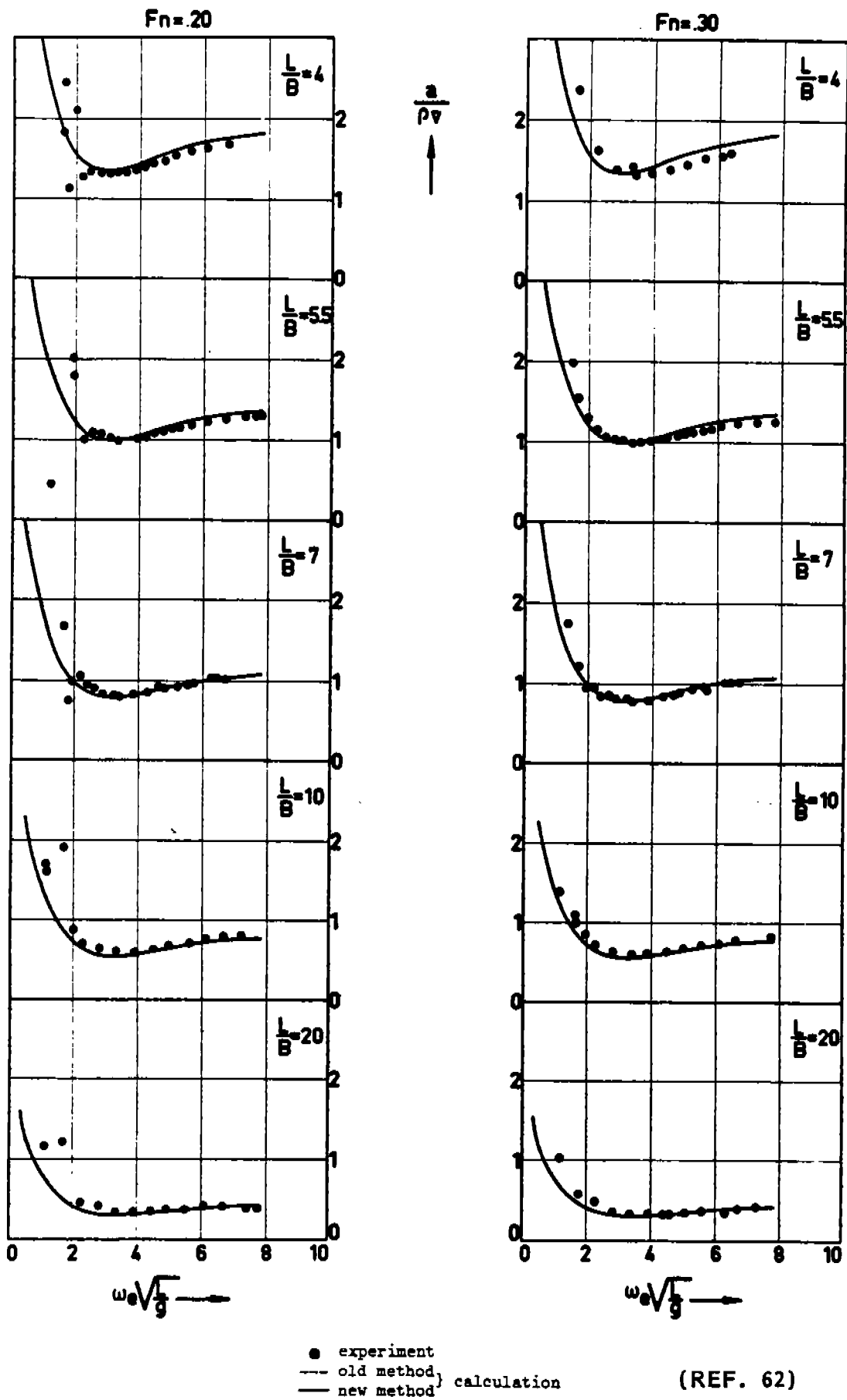

FIGURE 11 - ADDED MASS COEFFICIENT FOR HEAVE

(REF. 62)

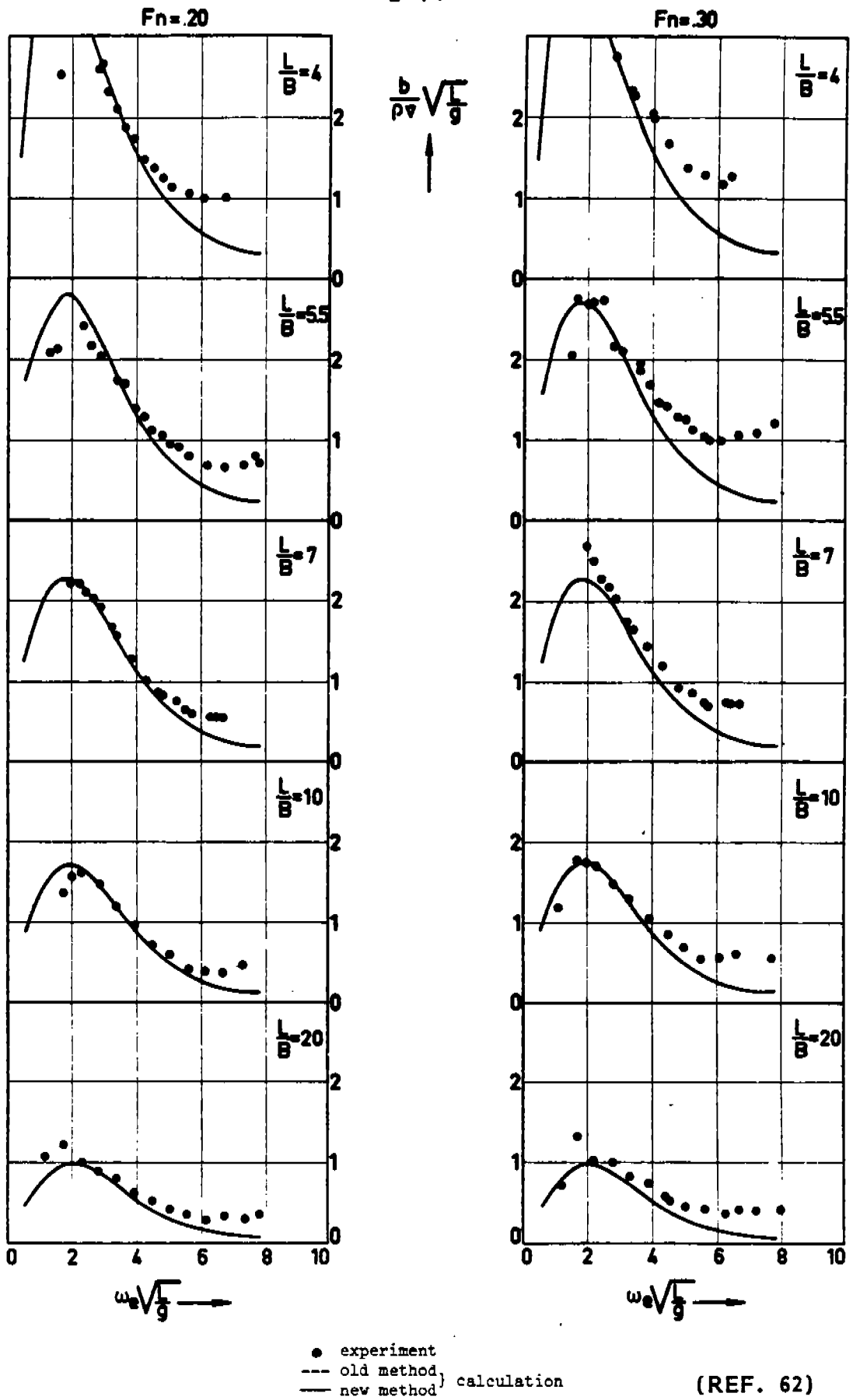

FIGURE 12 - HEAVE DAMPING COEFFICIENT

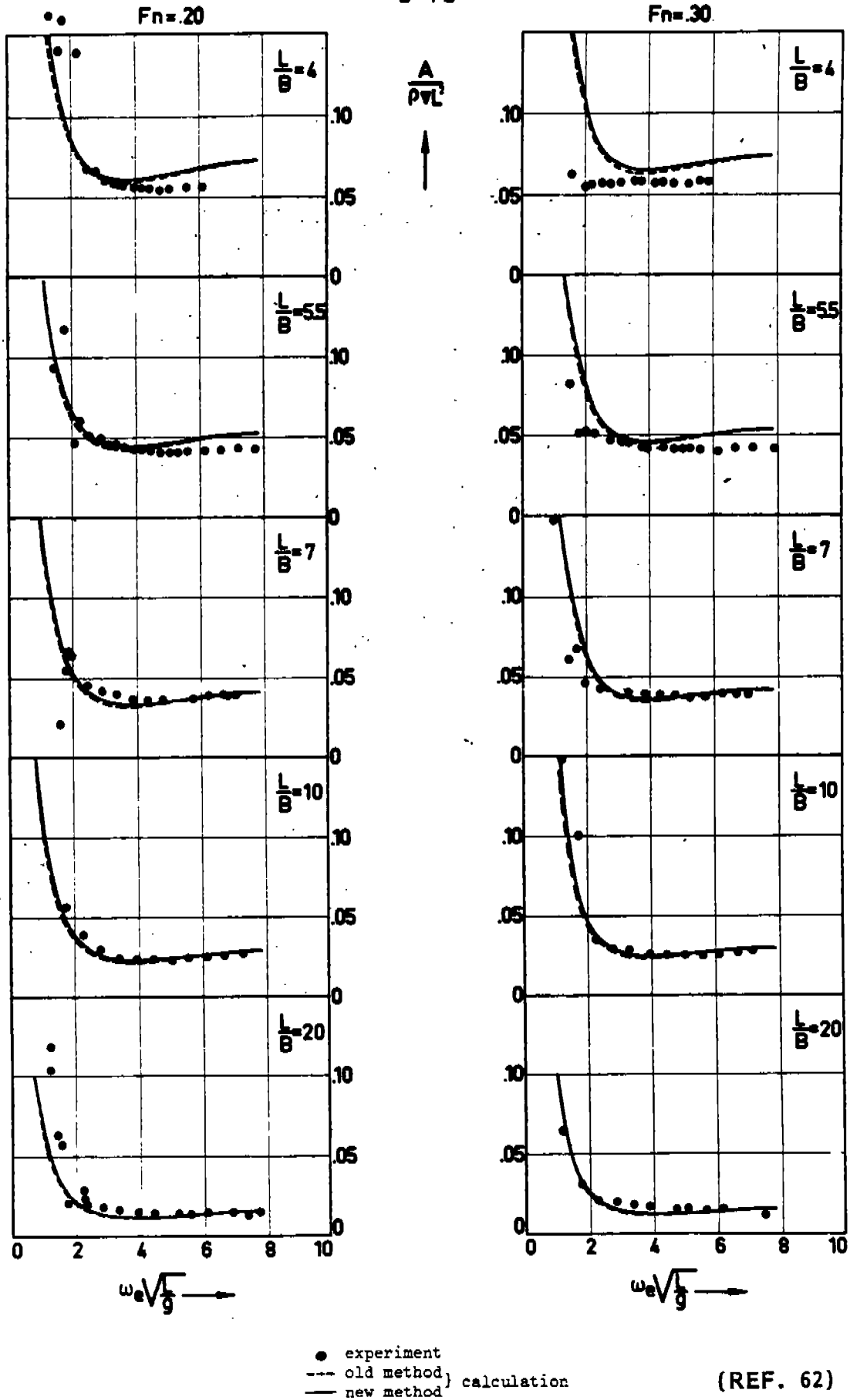

FIGURE 13 - COEFFICIENT OF ADDED MASS MOMENT OF INERTIA FOR PITCH

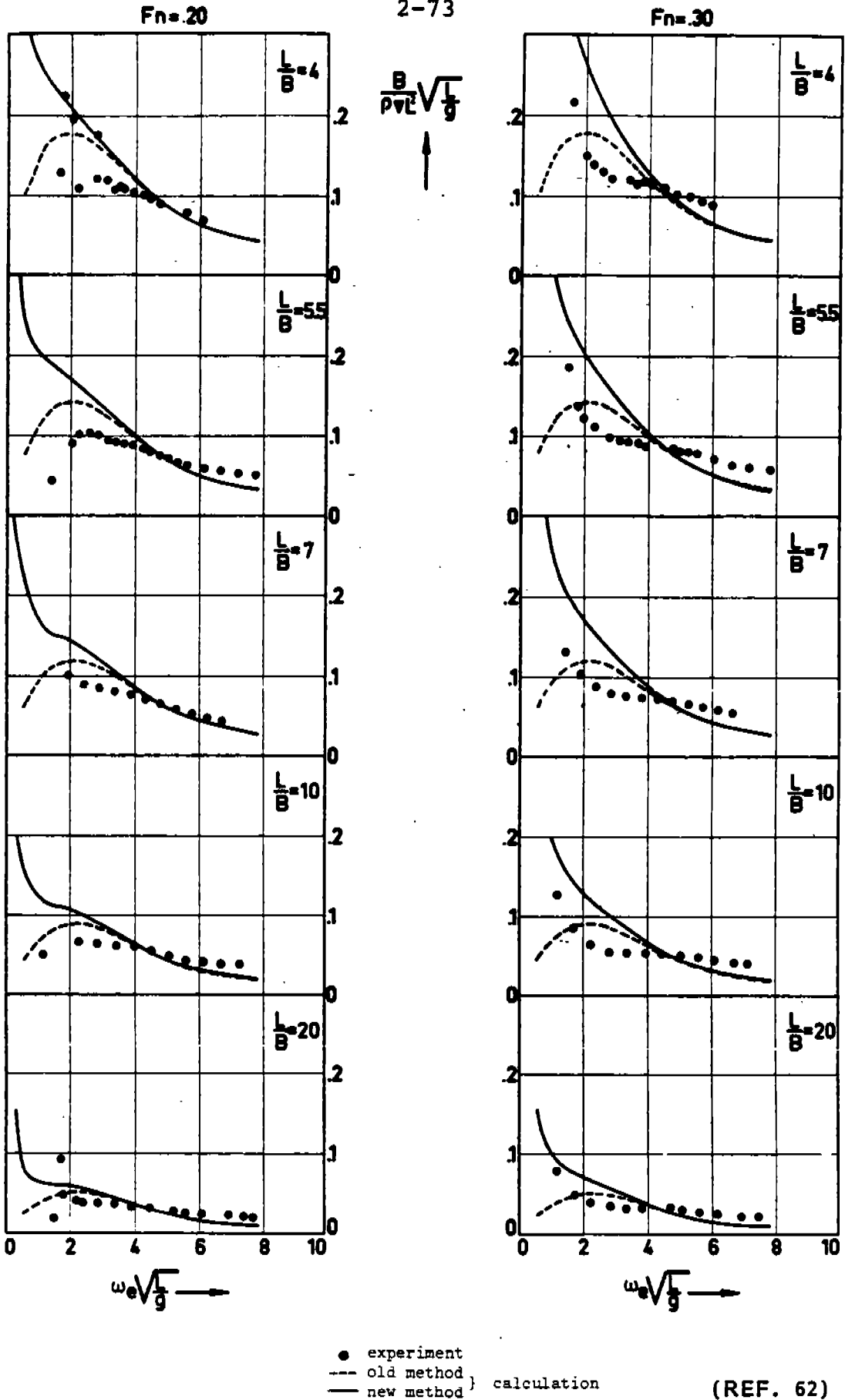

FIGURE 14 - PITCH DAMPING COEFFICIENT

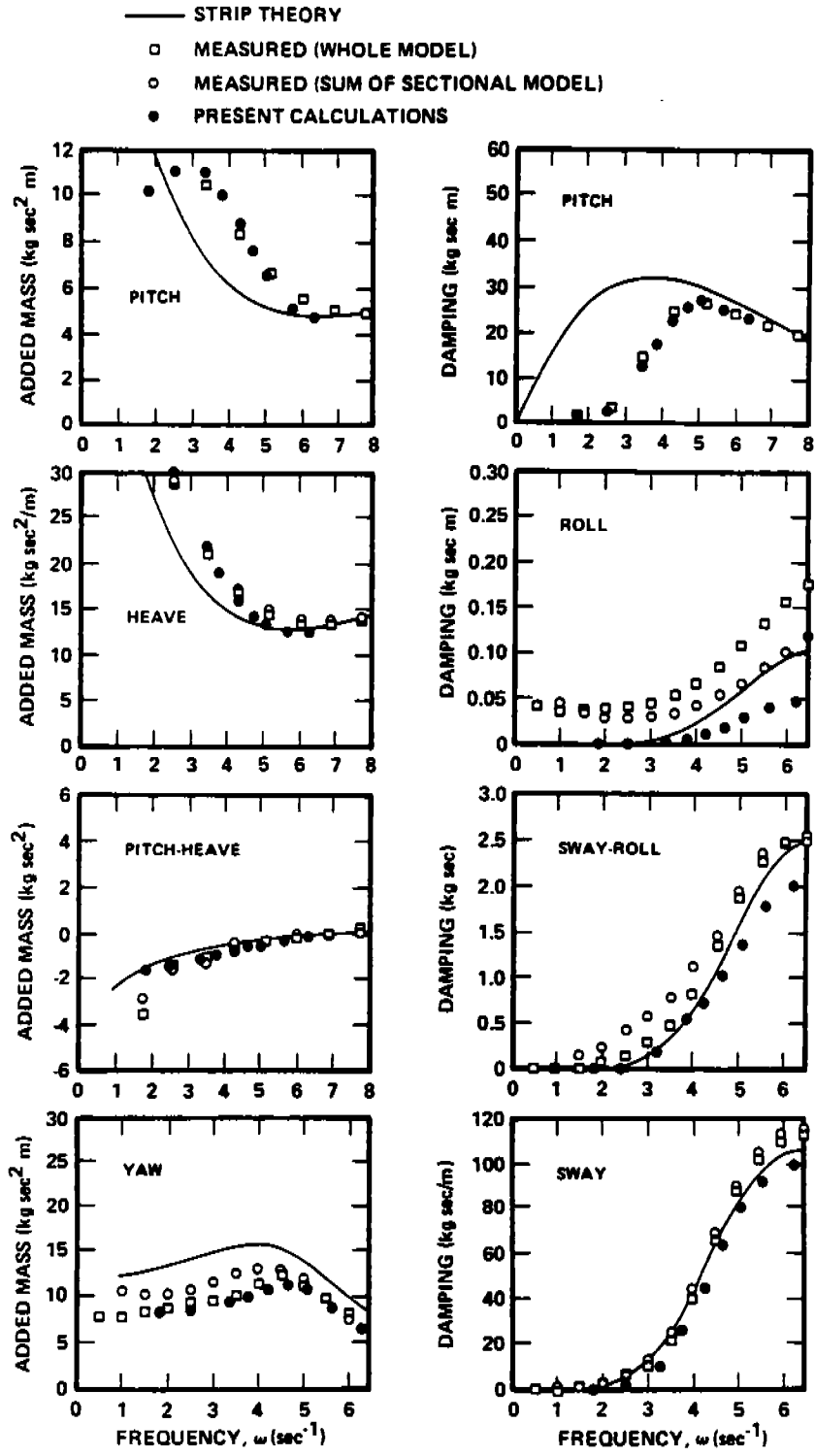

FIGURE 15 - ZERO-SPEED MOTION COEFFICIENTS FOR SERIES 60, $C_B = 0.70$ HULL MODEL, FROM REF. 70

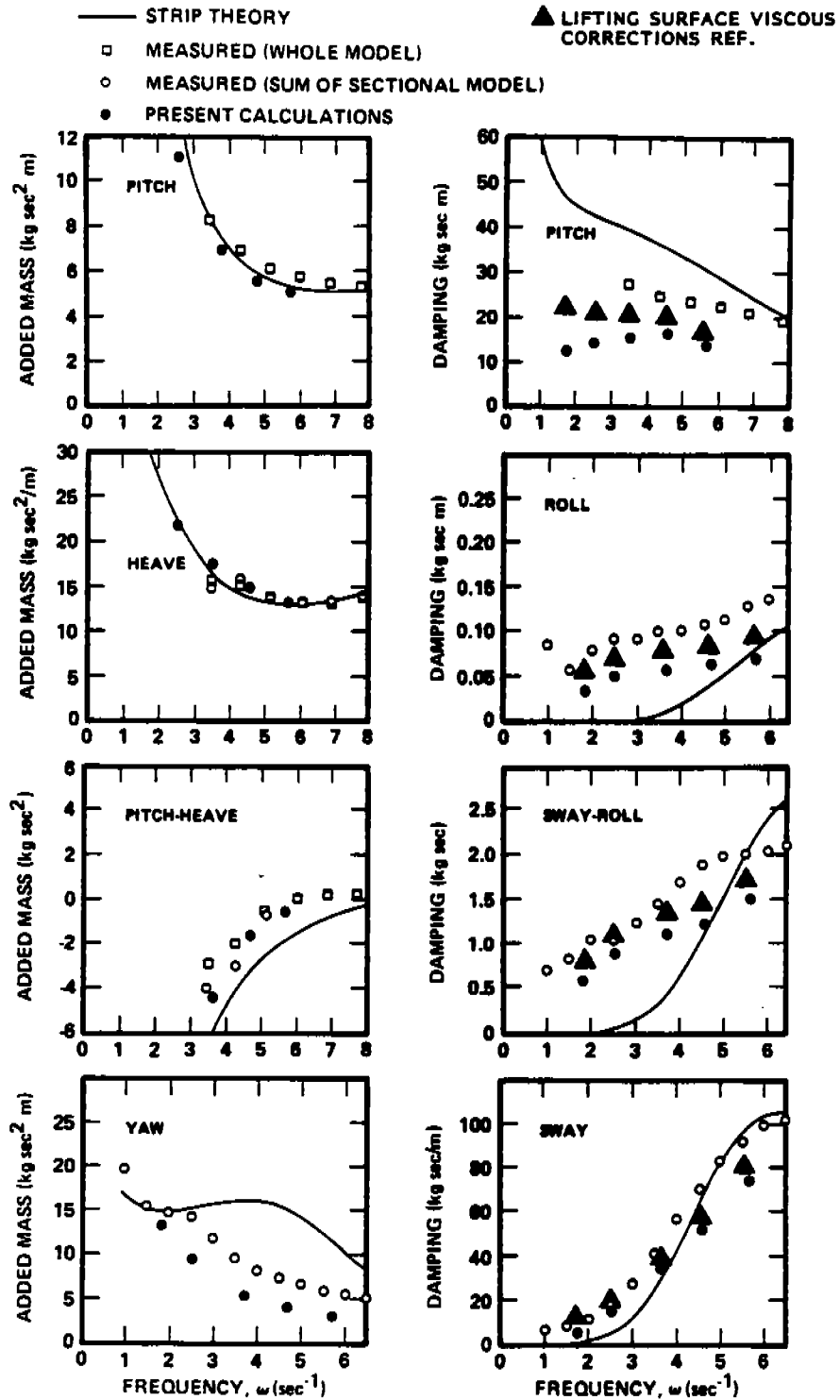
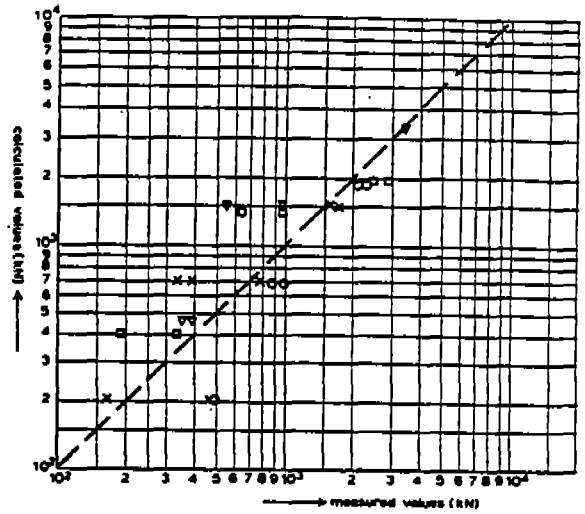
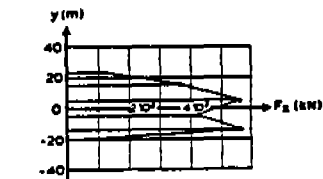
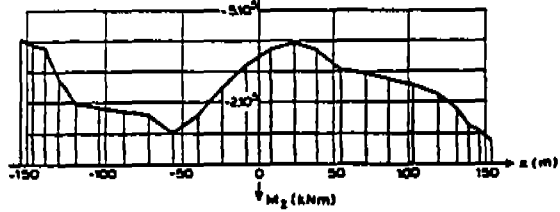
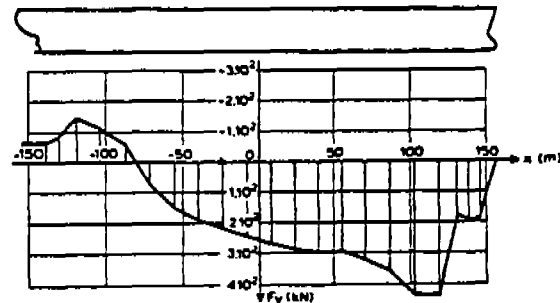
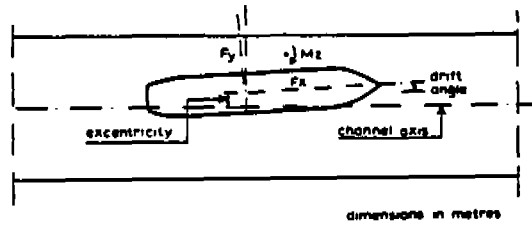
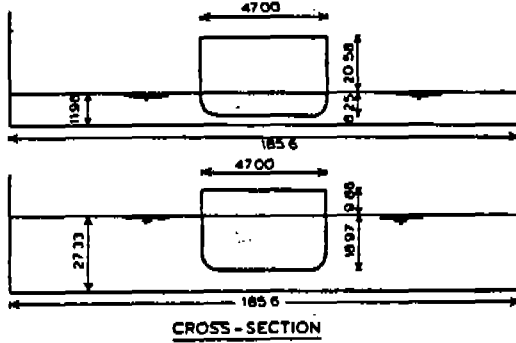
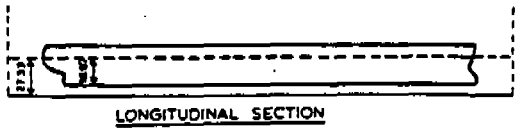
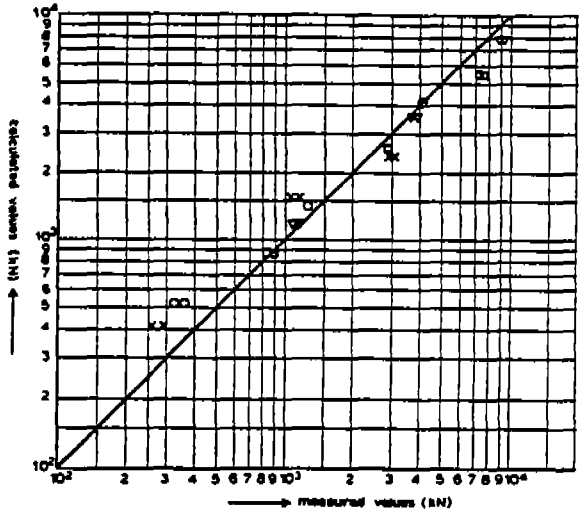

FIGURE 15 - MOTION COEFFICIENTS FOR SERIES 60,
 $C_B = 0.70$ AT $Fr = 0.20$, FROM REF. 71
 (CONCLUDED)

exc. draught
 00,025 - X
 1980,825 - O
 00,1897 - a
 1980,1897 - v



CALCULATED AND EXPERIMENTAL DATA FOR F_x



CALCULATED AND EXPERIMENTAL DATA OF F_y

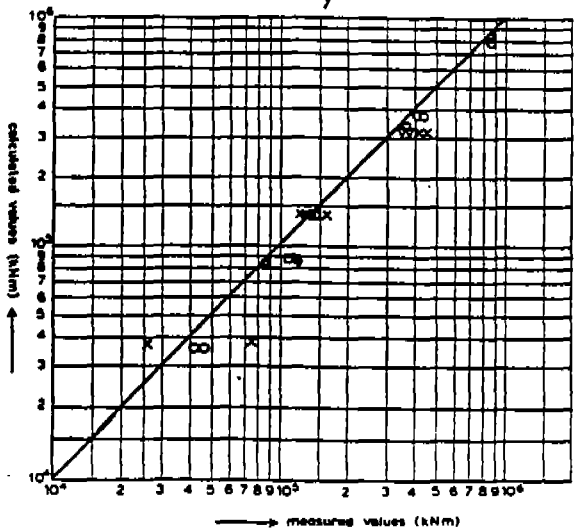

CALCULATED AND EXPERIMENTAL DATA FOR M_z

FIGURE 16 - NUMERICAL PREDICTIONS OF SHIP HYDRODYNAMIC FORCES FROM REFERENCE 44

TABLE 3 - EFFECT OF CARGO ON DAMPING, FROM REF. 11

Reference	Ship (Cargo)	Condition (dwt)	$c/\mu\omega$	Increase due to Cargo*	Comments
Taylor 1-22	Cargo Ship (general)	Part load (6550)	.006		Very crude res
		Full load (12700)	.006	None	
Aertssen and de Lembre 1-23	218 m ore carrier (ore)	Ballast	.0117 (mean)		Within experim scatter
		Loaded	.0124 (mean)	+ 5%	
Aertssen and de Lembre 1-24	146 m cargo liner (general)	Part load	.0204 (mean)		No change if high reading in load condition
		Full load	.0226 (mean)	+ 11%	
Aertssen and de Lembre 1-24	128 m container ship	Normal (8 m draught)	.0140 (mean)		Comparability of question by re differing weath operating condi
		Deep (9 m draught)	.0207 (mean)	+ 48%	
Johnson 1-8	127 m riveted dry cargo ship (water ballast)	Light (7000)	.0146 (.0095)		Forced vibration (Free vibration)
		Deep (13270)	.0162 (.0130)	+ 11% (+ 38%)	

*Assuming none due to hydrodynamics.

TABLE 3 - CONCLUDED

Reference	Ship (Cargo)	Condition (dwt)	c/ $\mu\omega$	Increase due to Cargo*	Comments	
Johnson 1-8	127 m welded dry cargo ship (water ballast)	Light (7500)	.0076		Within experimental scatter	2-Node Mode (cont'd)
		Deep (13500)	.0083	+ 8%		
McGoldrick and Russo 1-25	161 m dry cargo ship (general, including cars)	13750	.0140			3-Node Mode
		16840	.0366	+160%		
		13750	.0168			4-Node Mode
		16840	.0414	+145%		

2-78

Ref. 1-22 Taylor, J. Lockwood, "Vibration of Ships," Trans. INA, Vol. 72, pp. 162-196, 1930.

Ref. 1-23 Aertssen, G. and R. de Lembre, "Calculation and Measurement of the Vertical and Horizontal Vibration Frequencies of a Large Ore Carrier," Trans. NECIES, Vol. 86, pp. 9-12, 1970.

Ref. 1-24 Aertssen, G. and R. de Lembre, "Hull Flexural Vibrations of the Container Ship DART EUROPE," Trans. NECIES, Vol. 90, pp. 19-26, 1974.

Ref. 1-25 McGoldrick, R. T. and V. L. Russo, "Hull Vibration Investigation on SS GOPHER MARINER," DTMB Report 1060, July 1956.

Ref. 1-8: Johnson, A. J., "Vibration Tests of an all-welded and all-riveted 10,000 ton Dry Cargo Ship," Trans. NECIES, Vol. 67, 1951, pp. 205-276.

GENERAL-PURPOSE STRUCTURAL ANALYSIS CODESSUMMARY OF FEATURES AND CAPABILITIES

	<u>NASTRAN</u>	<u>ANSYS</u>	<u>CE/MARC</u>	<u>SAP4</u>	<u>STRU DL</u>	<u>STARDYNE</u>
STATIC						
IMPOSED DISPLACEMENTS	X	X	X			X
THERMAL STRESSES	X	X	X	X	X	X
DYNAMIC RESPONSE						
MODAL TRANSIENT	X		X			X
DIRECT TRANSIENT	X	X	X	X	X	X
STEADY STATE FREQUENCY	X	X				X
RANDOM (ACOUSTIC)	X					X
RANDOM (FORCE)	X	X				X
RANDOM (BASE)						X
SHOCK RESPONSE SPECTRUM		X		X	X	X
NONLINEAR						
MATERIAL	X	X	X			
LARGE DEFLECTION	X	X	X		X	
FRACTURE		X	X			
CREEP	X	X	X			
BUCKLING/COLLAPSE	X	X	X			
GAP/BOTTOM OUT/LIFT OFF	X	X	X			X
DATA CONVERSION						
SHOCK SPECTRUM TO TIME HISTORY						X
TIME HISTORY TO SHOCK SPECTRUM		X				X
PSD TO TIME HISTORY						X
TIME HISTORY TO PSD						X
FREQUENCY TO TIME HISTORY						X
TIME HISTORY TO STEADY STATE FREQUENCY						X
FLUID FLOWS						
FLUID - STRUCTURE INTERACTION	X	X				
HEAT TRANSFER	X	X	X			
ELECTROMAGNETIC	X	X				
COMPOSITE MATERIALS	X	X				
INITIAL STRAIN		X	X			

TABLE 4 - SUMMARY OF CAPABILITIES OF SOME STRUCTURAL
NUMERICAL CODES

3.0 PHASE II - MODEL TEST PLAN AND CALCULATION PROCEDURES

3.1 Objectives

The primary objective of Phase II is the establishment of a reliable basis for separation and identification of the different components of vibration damping. Combined with results of full-scale measurements, the proposed model test program should increase understanding of the physical vibration damping phenomena and provide guidance for development of a methodology for predicting damping as a function of ship parameters and service conditions. The ultimatum is to secure sufficient confidence in vibration prediction procedures, particularly for resonance conditions.

The following are specific objectives of the combined calculation and model testing efforts of Phase II:

(a) Establishment of suitable analytical and numerical procedures to estimate the components of vibration damping shown in Table 2.

(b) Determination of the magnitude and possible distribution of the components of hull damping for representative ship parameters and service conditions.

(c) Isolation and determination of the magnitude and distribution of the damping components by conducting specific model tests and measurements for specified excitations.

(d) Isolation and determination of effects of the excitation frequency and natural frequencies on the damping coefficients.

(e) Isolation and determination of effects of the forward speed, water depth, hull flexibility, and possible hydroelastic effects.

(f) Isolation and determination of effects of cargo variation.

(g) Correlation of the measurement of results with the various existing ship vibration theories, assessment of the validity of calculation theories and techniques, as well as determination of limitations of the experimental technique used.

(h) Provide information relevant to full-scale vibration measurements.

3.2 Scope of Model Test Program

The subject of vibration damping is too broad and too complicated to realistically expect to cover all possible research avenues in one program.

It was noted in Section 2.0 that both the analytical and experimental technique, to estimate damping coefficients currently used in design and vibration analysis are inadequate for realistic predictions of ship hull responses. The principal difficulties are due to the lack of understanding of the mechanism of energy dissipation in the structural, cargo, and hydrodynamic damping components (structural, cargo, and hydrodynamic) and uncertainties in separating and measuring these components directly from experiments.

The research plan outlined here is a reasonable compromise among the following major considerations:

(a) The specific requirements of the maritime community in regard to the scope and quality of damping data. It is clear that these data should be in the form and domain of interest to the users and be in the range of variables likely to be encountered in ship design.

(b) Selection of available analytical models, numerical procedures, testing, and data analysis methodology together with the required material and instrumentation.

(c) Cost and time duration restraints.

The underlying philosophy in the design of the plan is to obtain the highest possible quality of the study, and to provide reliable damping data at reasonable cost within a reasonable time period. In many ways, it is an exploratory study intended to provide some clues to understanding of the mechanism of energy dissipation based on the current level technology. Accordingly it is proposed to minimize the number of ship types to be studied and to conduct complete and comprehensive tests and calculations for those ships. Selection of a modern unitized cargo vessel and a mid-size product tanker are suggested for detailed study in Phases II and III of the program. The major results and findings of this work can be generalized for other types of vessels. More discussion of ship selection is presented in the following chapter with regard to full-scale experiments.

3.3 Model Test Theoretical and Numerical Procedures

With regard to the specific work items to be performed in Phase II of the project, the following key elements should be noted:

(a) Physics of vibration phenomena, particularly in regard to generally non-linear energy loss processes, is not well understood. Available theoretical and numerical techniques specifically developed for hydrodynamic applications have not been systematically applied to vibration analysis. No quantitative conclusions can be made in regard to their suitability for vibration damping and response estimates. There is little information on the distribution of damping along the hull, and effects of frequency and mode shape damping cannot be measured directly from experiments. The measurements provide only the total response due to certain controlled excitation, and damping coefficients are defined by the predetermined vibration model. These coefficients are associated with the chosen model, and, because of inevitable test errors, the coefficients also inherit all the limitations and shortcomings of the model and analysis method.

(b) A scale model cannot accurately represent a ship at sea. Hydrodynamic damping requires similarity of Froude and Reynolds numbers and scaling of inertia, and viscous forces. Structural damping must be related to the principal ship dimension, modulus of elasticity and stiffness parameters. Some of the important scaling relationships for full scale and model are shown in Table 5. However, since the model experiments cannot be conducted to simulate the responses of the full-scale vessel, scale effects can be minimized by

choosing a model of sufficient size to avoid viscous scale effects.

(c) Measuring and computing techniques typically employed are based on single-degree-of-freedom systems. Recently, several new measuring and data analysis techniques have been introduced and their use is recommended for damping identification in the present project.

3.4 Analytical Methods and Calculation Procedures

The plan for developing analytical methods and calculation procedures will have the following objectives:

(a) Identification of a suitable theoretical model and numerical procedures required to develop practical methods for estimation of parameters associated with damping of beam mode vibration.

(b) Provide numerical results and guidance on standard procedures used in ship design and vibration analysis, ranging from the semi-empirical and beam-type assessments to the comprehensive three-dimensional finite element techniques.

3.5 Recommended Problem Solution

3.5.1 Overall Damping Identification - Ship vibration damping is primarily the product of the dynamic interaction of two media: flexible solid structure and fresh or saltwater fluid. The structural damping, C_s , principally structural joint damping, seems to be a major source of inherent ship damping and, therefore, should be dependent on the ship

principal dimension, cross section area, A_S , torsional constant, J , and the modulus of elasticity, E , i.e.,

$$C_S = C_S (L, B, D, A_S, J, E) \quad [38]$$

Using theoretical formulations of structural mechanics and dimensionless pi-theorem, a more complete functional dependance of the structural damping coefficients from the leading ship structure parameters, can be developed.

The hydrodynamic components of damping, C_h , in addition to ship dimensions, will also be governed by the properties and velocities of the fluid. The principal dimensionless combinations in fluid dynamics physically representing the ratio of major force categories are:

$$\text{Froude number, } F_n = \frac{u}{\sqrt{gL}} = \frac{\text{inertia forces}}{\text{free-surface (gravitational forces)}}$$

where u is the ship speed,

g is the acceleration due to gravity, and

L is the characteristic length dimension.

$$\text{Reynolds number, } R_e = \frac{uL}{\nu} = \frac{\text{inertia forces}}{\text{viscous forces}}$$

where ν is the viscosity coefficient

$$\text{Strouhal number, } Sh = \frac{u}{nL} = \frac{\text{inertia forces}}{\text{unsteady (transient) forces}}$$

where n is the rotational speed.

Then

$$C_h = C_h (L, B, D, F_n, Re, Sh) \quad [39]$$

Using the general Equations [38] and [39], together with Equations [3] and [5], a general theoretical basis for vibration damping analytical or experimental investigations, and analysis of the existing test data can be established. From this basis, the following tasks can be undertaken:

(a) Development of simple theoretical models based on available knowledge. Presumably, the analysis of the hydrodynamic damping components will not cause serious problems because examination of fluid induced forces (damping and part of the added mass) from the frequency, forward speed and viscous parameters and major body parameters is a well developed area related to the treatment of ship motion. The structural damping is primarily due to the friction and plastic deformations between structural joints. There are several hypothesis on the origin and modeling of this component. Traditionally the structural damping is considered to have two components: viscous structural damping and Kelvin-Voight structural damping. Discussion of these components is given in Reference 77. Local structure vibrations can be based on models simulating the coupled damped vibrations of the beams carrying several rotating masses with an extrapolation on more complicated ship structure. The purpose of this modeling is to find leading parameters and develop relationships as in Taylor's and Kumai formulations, Equations [12] to [15], for more accurate ship vibration damping identification. An expansion of the practical relationships such as Taylor's for different ship types and dimensions may be useful.

(b) Re-examination of available data from past damping tests. It should be noted that a significant amount of vibration data is proprietary, and aid in obtaining such data should be requested from the SSC, ISSC or other appropriate agencies.

(c) Establishment of magnitudes of the unknown functional parameters in Equations [3], [4], and [5]. This task will involve applying some of the optimization or curve-fitting procedures to the available test data. Standard probabilistic techniques available on many current computer systems may be also used. A System Identification Technique may also be appropriate.

• The developed theoretical models and formulations will also be used for model test design and will be verified by the test results obtained in the project.

3.5.2 Hydrodynamic Damping - Hydrodynamic damping as a function of hull geometry, frequency of excitation, forward speed, and waterway restrictions, will be investigated. Longitudinal distribution of the hydrodynamic damping, accounting for effects of hull flexibility and ship motions characteristics, will also be investigated. It is proposed to study this component in significant depth because many important items in fluid/structure phenomena are unresolved, including the following:

(a) Importance of the hydrodynamic contribution to the overall vibration damping is a controversial and largely unresolved issue in vibration analysis. There are strong indications that the key factor is the different frequency

dependence of these components. In the low frequency range, the hydrodynamic damping is relatively large and might be important because the total, mostly structural, damping is low. In the high frequency range the opposite situation applies. A significant reduction of the hydrodynamic damping is accompanied by similar significant increase of the structural and, therefore, total damping. The accurate definition of the boundaries between these two regions is uncertain and it is dependant on the characteristics of the ship hull and its structural system.

(b) Hydrodynamic phenomenon of fluid structure interaction is very complicated and is difficult to manage numerically because pressure/wave and viscous components are coupled, non-linear, functions of frequency, ship motions amplitudes, and forward speed. For flexible vessels, the problem becomes more complicated by hydroelastic phenomena that involve a mutual interaction of hydrodynamic and elastic forces. Available engineering methods to evaluate hydrodynamic phenomena are based on many simplified assumptions. Validity of these assumptions should be examined by comparisons with the model test data, and the best overall procedures should be recommended for engineering practice.

The hydrodynamic damping study program should include the following items:

(1) Two-dimensional (2-D) hydrodynamic analysis and numerical calculations based on strip and/or slender body theories. See References 61 to 68. There are significant differences between different approaches, particularly in regard to the forward speed effects and magnitude of the

frequency for moving ship, i.e., frequency of "encounter" of the hull with the water versus "true" or natural frequency of wave dissipation. These differences should be identified and numerically estimated for comparisons with test data and further analysis. These methods typically give the total value and distribution of hydrodynamic damping along the hull, and several 2-D numerical codes have a capability to account variation of water depth.

(2) It is generally recognized that stripwise methods and the associated 2-D hydrodynamic coefficients are inaccurate for regions near the bow and stern. So-called "3-D corrections" have been used with limited success. Corrections factors proposed in Reference 65 and J-factors in Reference 66 should be assessed. Based on recent experience, the following additional three factors in this context, which have been omitted in all previous investigations, should also be considered:

(a) Variation of the longitudinal speed component along the hull. Even for very fine ship forms without abrupt changes in hull shape, the longitudinal velocity value which enters many important hydrodynamic terms is not equal to the ship forward velocity, as typically assumed in most strip techniques. Recent estimates showed that in some cases longitudinal speed corrections are more important than three-dimensional geometrical effect on the sectional hydrodynamic forces. Variations of the longitudinal velocity along the ship can be approximated from the calculations for the 3-D ellipsoids, having the values of L, B, and T of ship-like bodies.

(b) It has been recognized from the analysis of calculations and experiments that in the pitching mode the predicted values of the hydrodynamic coefficients obtained by strip methods are typically in worse agreement with the tested value than in heave. Non-linear amplitude factor changing along the hull, from zero in the middle to the maximum values in both ends, can potentially contribute to this discrepancy.

(c) Viscous factors, both linear lifting type at low frequencies and non-linear "quadratic" factors at high frequencies, should be estimated. One possible approach is proposed in Reference 68.

(3) There are literally hundreds of the 3-D software packages suitable for predicting damping and inertia coefficients. However, most are based on linear theory and do not consider the forward speed effect. The majority of these packages are proprietary or in research use, and calculations are fairly expensive. Linearized 3-D methods including the forward speed effects are described in Reference 70 and 71, and are under development at the University of Michigan. Numerical codes MAC, SMAC, and SOLA-VOF, solving viscous flow equations by the finite difference methods, are available from the National Energy Software Center. The most advanced algorithm in these numerical codes, "HYDR-3D", is commercially available from Flow Science Inc., Los Alamos.

During the selection of the appropriate 3-D numerical code for the project a careful balance between the quality and magnitude of the calculations versus cost should be considered. The following additional items also should be considered:

(a) Linearized non-viscous 3-D methods such as described in References 70 and 71 explicitly identify the linear damping coefficients of a rigid body as a function of frequency, forward speed and water depth. This damping is exclusively of wave-making nature, so that at very high frequencies the magnitude of the wave damping is zero. Viscosity of the flow and hull flexibility are not accounted for by these codes. Despite these limitations, damping and added mass calculations are expected to be very useful for this project, particularly if a hull generation mesh can be used for both hydrodynamic and structural calculations. It will be highly desirable to obtain a distribution of damping along the hull for some representative cases for further comparisons with stripwise calculations and model test data.

(b) Advanced non-linear codes, such as SOLA or HYDR-3D, are free from limitations imposed by linearity requirements and negligence of viscosity, but include approximations to describe the average turbulent flow tensions. Besides being significantly more time-consuming than linear codes, they provide only the pressure distribution and total force in time domain. It is difficult if not impossible to define damping term in conventional manner. However, these codes can work together with some advanced FEM structural programs by providing the local hydrodynamic force as an external input for each time increment. For realistic overall ship response predictions these codes are clearly superior compared with any beamlike or more sophisticated linear models.

3.5.3 Estimation of Other Damping Components - Following determination of hydrodynamic damping, the following procedure for obtaining other damping components is proposed:

(a) Select representative ships for comprehensive damping evaluation. Vessels for which reliable full-scale measurements are available are preferred, and numerical analysis should include a full-scale equivalent of a tested model.

(b) Estimate material damping on the basis of the existing formulations. See References 42, 43, 75, and 79. Establish relative contribution of material damping to the overall damping coefficient.

(c) Investigate the effects of hull flexibility and ship motions parameters on the magnitude of hydrodynamic damping, considering the hull to be an elastic beam and using strip theory methods. Numerical calculations should also cover model test conditions for further comparison with test data.

(d) Estimate cargo damping using available theoretical and numerical techniques, including development of practical methods to estimate damping component due to solid, dry bulk, and liquid cargoes.

Values of the cargo damping for representative cases should be calculated and the contribution to the overall damping coefficient determined.

The cargo damping component for model testing conditions should be estimated for further comparisons with the test data.

Estimate the total value of damping on the base formulations developed earlier, and compare predictions and measurements.

3.6 Plan for Model Testing and Damping Components Analysis

3.6.1 Objectives:

(a) To obtain adequate and reliable data for the prediction of damping coefficient components.

(b) To isolate and measure the magnitude and distribution of the hydrodynamic damping as a function of frequency, forward speed, depth, hull stiffness. To a lesser degree, to examine hydroelastic effects and effects of amplitudes of motion.

- To determine the material and cargo damping components.
- To verify the corresponding analytical models previously developed.
- To provide information for correlation with the predicted results and for full-scale measurements.

3.6.2 Model Design and Construction

(a) Model Scale - The selected model characteristics should correspond to the characteristics of full-scale vessel selected for damping measurements. The model should be sufficiently large to avoid possibility of scale effects in the damping model tests and to provide a sufficient space for cargo instrumentation measuring equipment. Major structural components of the selected vessel should be in scale. Even though the data from the model experiments are not to be used for the simulation of the full-scale vessel (except for the coefficients of hydrodynamic and possible cargo damping), they

are still useful data for the verification of ship vibration theory. A realistically scaled model is, therefore, important in order to assure the confidence of the designers in application of the theory. The scale of the model should also meet limitations and requirements of a model testing facility. The principal model parameters must correspond to the scaling laws given in Table 5.

(b) Model Design and Construction

The models will be segmented to represent a ship hull in a discrete manner similar to the analytical lumped-mass approximation used in beam-like vibration analysis. A minimum of ten equally spaced segments will be required to obtain adequate results. The segments should be very rigid and joined by flexible connecting devices on the continuous beam, simulating the elastic line of a flexible ship. The deformation of the model will occur primarily in the connections between the segments where the appropriate measuring devices will be placed.

The shell and deck of the model can be made of rigid vinyl or glass reinforce plastic. There are several advantages of vinyl over other materials, including:

Low elastic modulus of about 500,000 psi allows adjustment of model hull flexibility to obtain good measurements with small excitations.

- Vinyl models are more economical and easier to work with than wood or metal. Manufacturing of vinyl models is an established practice.

Stiffness variation capability is required. Removable stiffeners with different stiffness characteristics could be used. Variation of the modulus of elasticity can be achieved by adding metal plates or stiffeners to the hull. Flexible segment connections should be designed to obtain the limiting case of a practically rigid model.

The model can be mounted on specially designed supports. Spring stiffeners in these supports can be adjustable or readily replaced with different springs so that the effects of different natural frequencies can be simulated. The mount supporting the model should be so designed that it can be easily attached to the towing tank facilities so that the effects of forward speed can be measured.

Instrumentation will be installed on at least five stations along the hull for the measurements of displacement, accelerations, and bending moments.

Rotating mass vibration generators can be used for excitation. The vibration measurements resulting from excitation will be measured for different frequencies in air and in water.

Since the model in most of the tests will not be as free as the full-scale ship, the forces imposed by the supports must also be measured and/or calculated, based on measurements of the displacement and acceleration of the hull.

3.6.3 Excitation Devices; Measuring, and Recording Instrumentation - Design of vibration generators for model testing is based on the same principles as in full-scale tests,

consisting of rotating mass vibration generators, hammers, etc., as described in Chapter 4. Some model testing facilities have harmonic oscillators which may be used, depending on size of the model and magnitude of the exciting force. For example, for large amplitude and low frequencies, the Large Amplitude Horizontal Planar Motion Mechanism System (LAHPMM), used in the Hydronautics Ship Model basin, is capable of oscillating and measuring forces on large models up to 30 feet long and weighing several tons. For the high frequency range extending to the hydroacoustic and noise levels, small oscillators are typically used.

The specifications of the measuring and recording techniques for model testing are well established and are well described elsewhere. Typically, the test results are recorded on magnetic tape for further analysis by computers. During the tests, however, it is recommended that a partial analysis be performed, e.g. by using FFT real-time analyzer, and estimate damping for some representative cases. This procedure ensures consistency of measurements and will also help to identify possible test errors during the experiments. Some of the equipment used in the vibration testing practice is described in Appendix A.

3.7 Excitation and Damping Coefficient Identification

Solutions for free and steady state harmonic vibrations are discussed in the following paragraphs:

3.7.1 Free Vibrations - Equation [14] for undamped free vibrations reduces to

$$S' = KS + \bar{M} \ddot{S} \quad [40]$$

Solution of this equation for harmonic vibrations provides an infinite set of eigen values and eigen vectors, ω_n and S_n , which satisfy the given boundary conditions and the conditions:

$$S_n' = (K - \bar{M} \omega_n^2) S_n \quad [40a]$$

where ω_n and $S_n(x)$ are the natural frequency and mode shape for the n mode and for the corresponding boundary conditions. Methods for solutions of S_n are well known.

3.7.2 Forced Vibrations - Assuming the form of solution as

$$S(x,t) = \sum A_n S_n(x) \cos(\omega t - \theta_n) \quad [41]$$

Equation [41] reduces to the following system, from Reference 11:

$$\sum A_n [(\omega_n^2 - \omega^2) N_{mn} \cos(\omega t - \theta_n) - \omega D_{mn} \sin(\omega t - \theta_n)] = F_m$$

$$N_{mn} = L \int [(I_o + I_a) \theta_n \theta_m + (m_s + m_a) w_n w_m] dz$$

$$D_{mn} = L \int [C_o \theta_n \theta_m + C w_n w_m] dz$$

$$F_{cm} = F_{cm} \cos \omega t + F_{sm} \sin \omega t$$

$$F_{cm} = L \int (b_c \theta_m + f_c w_m) dz$$

$$F_{sm} = L \int (b_s \theta_m + f_s w_m) dz \quad [42]$$

where m_a and I_a are added mass and added mass moment of inertia. C_0 and C are damping coefficients, including all damping components.

Unless the damping is everywhere proportional to mass, the coefficients A_n for various modes are coupled by the terms associated with the damping. If the damping coefficients are known, this causes no problems. Equation [42] can be solved explicitly for as many A_n values as desired. All coupled terms can be taken into consideration.

For this project, the damping coefficients are unknown and must be determined from the measurements. The coupling of the damping terms becomes a problem. However, the solution is to excite the model or ship in such a manner that the response can be controlled to be primarily in one particular mode. Then, contributions from other modes become negligible and the off-diagonal terms in the matrix D_{mn} can realistically be neglected. This concept is the basis for the entire experimental program. The success or failure of the project rests on the ability to devise an excitation method which closely achieves this "single-mode" response for each of the modes of interest.

For the uncoupled motion, Equation [41] will give the following solution:

$$S(x,t) = \sum \frac{f_{nc}^2 + f_{ns}^2 \cos(\omega t - \theta_n)}{(\omega_n^2 - \omega^2)^2 + \mu_m^2 \omega^2} S_n(x) \quad [43]$$

where

$$f_{nc} = \frac{F_{cn}}{N_{nn}}, \quad f_{ns} = \frac{F_{sn}}{N_{nn}}, \quad \mu_n = \frac{D_{nn}}{N_{nn}}$$

The solutions of non-harmonic vibration are given in Reference 11. In harmonic excitations, the location and magnitude of the excitation can be determined by Equation [42]. Figure 17 shows that three excitation devices would be needed to simulate the first mode, i.e., the 2-node mode, or the third mode, i.e., the 4-node mode. Four excitation devices are required for the fifth 6-node mode. The excitation devices could be located in the antinode loops of the given mode form. A model or ship does not have a uniform distribution of properties along the length so that the location of the nodes is somewhat conceptual. However, the goal is to optimize the location and magnitude of the excitation on the model or full scale ship for each mode of vibration by minimizing the contributions of "off-frequencies" modes, while maximizing the desirable frequency mode effect.

3.7.3 Analysis Methods - It has been shown in the previous chapter that currently there are many methods to determine the damping coefficients. Although the model testing will be primarily based on steady state excitation, it is highly desirable that both the steady state and transient motions methods will be utilized, and both results will be compared for consistency and correlation with the predicted and full-scale results.

(a) Steady-State Excitation Analysis

If the excitation force is measured and contributions of different modes can be separated, the damping from Equation [44] can be calculated as follows:

Let $W_n(x)$ be a measured peak of a steady state vibration associated with the n -th mode, so that

$$W_n(x) = \frac{(f_{nc}^2 + f_{ns}^2)^{1/2} w_n(x)}{((\omega_n^2 - \omega^2)^2 + \mu_n^2 \omega^2)^{1/2}} \quad [44]$$

than damping, μ_n , becomes

$$\mu_n = \left[\frac{f_{nc}^2 + f_{ns}^2}{\omega^2} \left(\frac{w_n(x)}{W_n(x)} \right)^2 - \frac{(\omega_n^2 - \omega^2)^2}{\omega^2} \right]^{1/2} \quad [44a]$$

This formulation is called the magnification method, and is somewhat similar to the response curve method, also recommended. Analysis of the experimental data to determine damping can also be made on the basis of the following formula, recommended by Johnson and Ayling:

$$Q = \frac{1}{2\zeta} = \frac{N_{res}}{\Delta N} \sqrt{\left(\frac{a_{res}}{a_1} \right)^2 - 1} \quad [45]$$

where N_{res} and A_{res} are the frequency and the amplitude of the given mode of resonant vibrations, respectively. Other notations are evident from the sketch in Figure 18. This formula takes into account the shape of the response in the resonance region, and, therefore, provides a rather comprehensive description of the damping coefficient.

This valuable feature is also present in the circle-fitting parameter estimation of Reference 35 which is based on circle fitting through points in the vicinity of resonance. The damping ratio and the modal displacement are defined as an amplitude and phase by the position and dimension of the

circle. See Figure 2. Therefore, departure from the circle shape could be an indication of other factors, such as nonlinearity or noise. The method is well recommended for both model and full-scale testing damping analysis.

(b) The Distribution of the Damping Coefficients

Theoretically, the distribution of the damping along the ship model can be obtained on the basis of Equation [44] by determining discrete damping value and applying Equation [44] for each measured section. Integral value should be the same as for the whole model. Details of the analysis are given in Reference 11. Distribution of damping along the model hull can be obtained by both the steady state excitation and transient methods.

(c) Bending Moment Method

By measuring the bending and shear stresses, acceleration and velocity at each section location along the hull, the distribution and magnitude of the damping coefficients can also be obtained, following the procedure described in Reference 11. The intent of this method is to measure all parameters in the bending moment $[M(x_s, t)]$ expression at any cross section, x_s except damping, C .

$$M(x_s, t) = \int_0^{x_s} n [V(x, t) + I_0 \theta + C_0 \dot{\theta}] dx \quad [46]$$

where V and θ are slope and shear, respectively.

For these reasons, it is recommended that displacements, the basis for all previously discussed methods, as well as bending moments, accelerations and velocities be measured. The bending moments can be measured by dynamometers at the joints for segmented models. The measured strain may also include the components due to local deformation. However part of this local effect can be excluded by putting strain gauges on both sides of the plates.

3.8 Model Test Procedures

3.8.1 General Considerations - Measurement of relatively small forces and responses in model vibration experiments is a delicate and complicated task. In order to assure the completeness and usefulness of the experimental data from model testing the following items should be considered:

(a) Excitation force must be large enough so that the displacements and other parameters can be reliably measured. Large forces and responses, however, may cause certain non-linear effects unaccounted for by the test analysis methods and theories. Therefore, it is essential that a complete record of model test conditions, model ballasting, and time histories of measured responses be maintained.

(b) The dynamic characteristics of the exciters, supports and supporting structure must be accurately described, analyzed, and presented with the data.

(c) Calibration conditions, methods, and results, for both pre- and post-measurements, must be described and recorded in detail.

It is not appropriate in this report to present a detailed test run schedule and description of the specific tests. However, the following practical considerations should be noted:

- Frequency range of interest should be estimated in the very early stage of model test design. The range depends on the type of vessel and the highest mode of vibration chosen for the test. Quality and cost of model test results will be significantly determined by the number of test points required to cover the required frequency band and sufficiently define the resonance conditions. It is estimated that the minimal number of test runs over the frequency range will not be less than 20.

- Theoretically, the vibrating responses and estimated damping coefficients should depend linearly on the amplitudes of excitation. The test matrix should primarily cover this linear range with the corresponding compromise between response values and capabilities of the testing and data reduction equipment to record and analyze these data. Large motion tests should be reserved for selected representative cases, but should be in the range of "actual" ship operating conditions.

- Special consideration should be given to the reliability, repeatability and consistency of the test data. Due to the large amount of information recorded at each run, special test examination techniques, computerized preliminary data analysis, and, perhaps, visual display of the test data at the time of testing, should be considered. These procedures will minimize errors, and indicate requirements for modifying or repeating tests.

- Rigid-hull model testing to evaluate hydrodynamic damping should be carried out before the flexible model experiments. The same model can be used for both purposes if appropriate model hull stiffness can be obtained. Rigid model tests will be conducted only in the water, at both zero and forward speeds. The final tests should establish the extent of forward speed effected on damping and define the scope of similar tests on the flexible model.

- Flexible model experiments will require an estimated 85 percent of all model testing. The models would be excited both in air and in water to isolate the effects of hull flexibility. Structural damping will be constant for both cases so that the effect of hydrodynamic damping can be isolated. If forward speed effects are shown to be significant, the flexible model tests would also be conducted at forward speed in water.

3.8.2 Specific Test Procedures - The proposed model test program is summarized in the following listing of specific tasks:

1. Construct three beams to model the hull flexibility, making use of appropriate material for proper scaling.
2. Compute the frequencies and the vibration modes for the above beams.
3. Apply excitation to the beam in a manner to obtain only one mode at a time.
4. Measure the frequencies and the vibration modes for the above beams.

5. Measure or calculate the accelerations, displacements, and curvature. Accelerations should be measured at enough points so that a continuous curve of acceleration can be plotted. From this curve, the deflection and velocity curve can be constructed.

6. Estimate material damping using existing theories of internal damping.

7. Determine the dynamic magnification factor and damping ratio for the first five modes of vibration and compare the measured and calculated values of these parameters.

8. Conduct excitation tests in the range of frequencies to obtain a response curve around resonance in the first mode of vibration. Estimate the damping coefficient using formulas [44], [45] and response curve and circle lifting parameter methods, and compare with the results in item 7, based on single-point measurements. It is expected that magnitudes of the damping coefficients, which account for the real shape of the transfer function response in the resonance region, and therefore reflect important dynamic properties of the system, are more accurate than those determined from "single point" measurements.

9. Construct model of the representative vessel.

10. Conduct ship motion tests in still water and in regular waves using a rigid model and to obtain response functions.

11. Attach the beams to the model.

12. Repeat steps 3 through 8 for these flexible beam supports for different simulated dry and liquid cargoes with different cargo distributions, and measure frequencies and damping.

13. Isolate and determine material and cargo damping components as a function of variable hull flexibility, modes of vibration and longitudinal distribution of the cargo along the length.

14. Repeat the vibration tests, step 12, in still water and at service speed, at full load, light and ballast conditions, for different cargo distributions and different water depths. Determine the value of the damping coefficients for all tested conditions.

15. Isolate and determine hydrodynamic damping component by subtracting the material and cargo damping from the total value of damping determined above in Step 14.

16. Assess effects of frequency, forward speed, waterway restrictions on the hydrodynamic damping and its distribution from the results of model tests.

17. Assess hydroelastic effects due to the forward speed on natural frequencies, damping, and inertia force.

18. Assess the contribution of material, cargo, and hydrodynamic damping on the basis of model tests.

19. Assess effects of model hull flexibility, ship motion response and finite amplitude and viscosity influence on different components of vibration damping determined from model testing.

3.9 Correlation of Calculated and Experimental Results

Correlation of analytical and experimental results generally infers the comparison between calculated and measured responses. For the damping experiments, however, the correlations involve such comparison, as well as examination of damping coefficient formulations and, indirectly, the validation of the ship vibration theories. Accordingly, a meaningful correlation of damping results should include a discussion of the inevitable experimental shortcomings as well as the limitations of the existing theoretical bases to identify damping qualities of the multimode degree of freedom ship/flow system.

It should be noted that although the goal of the whole experimental program is to correlate the measured responses with the various existing ship vibration theories, the correlation study based on model tests is intended to cover primarily the components of the damping coefficients and effects of variation of hull parameters, excitations and environmental conditions. Correlation of the predicted and measured vibration responses can be accomplished only by measuring the structural damping component in full-scale testing.

The following effects should be considered in the damping correlation study:

3.9.1 Effect of Excitation - The weight, motions and response of the exciter should be properly accounted for in model test analysis and damping coefficients evaluation.

3.9.2 Effect of the Material Properties - The material properties of the rigid vinyl and the steel strips should be properly accounted for. The responses of the model under the proposed excitation loads should not exceed the yield point of the material.

3.9.3 Effects of Water Restrictions and Depth of Water - Influence of water depth on the hydrodynamic components has been investigated in many prior studies. Theory and experiments are in generally good agreement. It is suggested that water depth effects be examined only for limited and representative cases. Effects of the water depth becomes almost negligible for water depths exceeding 3 to 4 times the draft and is little influenced by the ship speed. Wall restrictions in the model basin, particularly for large models at zero speed, might affect the vibration tests. It is recommended that zero-speed vibration tests be conducted in the middle of the model basin with the model oriented perpendicular to the tank axis. Channel wall effects in the longitudinal direction are considered to be small with negligible effects on the vertical and lateral vibrations.

3.9.4 Effects of the Local Deformations - The beam theory of ship vibration is based on the assumption that plane sections of the hull remain plain after deformation. In general, however, particularly for large loads, the plane sections may be warped and local deformation can change the shape of the cross-sections. It should be noted that the

measured data represent the total response at the measured location, including the beam girder and local responses. The load effects in model testing can be minimized by applying the excitation to major structural components. The contributions of the local response for both calculations and experiments can be isolated and identified because the natural frequencies of the local structure are generally, much higher than the hull girder frequencies.

3.9.5 Non-linear Effects of Viscosity and Final Amplitudes of Motions - Viscosity effects will always be present in hydrodynamic damping values determined by model tests. For very low frequencies they can be approximately estimated by lifting lines from aerodynamic solutions. However, at high frequencies, where most vibration resonances occur, the quadratic damping, probably becomes dominant. Approximate estimation of viscosity at high frequencies can be performed semi-empirically using the representative measurements employed in aerodynamic computations.

Final amplitude effects also will be present in the experimental data. While amplitudes must be sufficiently large for accurate measurement, they should not be excessive. Theoretical means to account for this effect were discussed in Section 2.

3.9.6 Other Required Correlations and Analysis - The following additional correlation analyses will be required:

(a) Comparison between the damping coefficients determined by the steady state and transient methods.

(b) Comprehensive comparison of the distribution of the hydrodynamic damping along the hull obtained from the test and by different hydrodynamic theories.

(c) Assessment of the limitations of the available beam-like methods to estimate damping along the hull. This assessment should account for results of the 3-D calculations and correlations factors discussed above.

(d) Recommendation of an engineering approach to calculate damping and added masses and, distribution of pressures along the hull as a function of ship hull parameters and environmental conditions.

3.10 Estimated Schedule and Level of Effort

The proposed tasks to be conducted in Phase II have been combined into the following larger tasks for budget and scheduling purposes.

Task I: Assessment of suitable calculation and test methods.

Task II: Analytical prediction of damping components.

Task III: Model testing and analysis.

Task IV: Correlation and damping assessment analysis.

The projected work plan and schedule for each task of the Phase II are shown in Figure 22. The figure indicates the duration of each task and schedule of deliverables. Duration of the Phase II effort is projected to be 14 months.

Estimated manpower and towing tank requirements for each of the four task groups are given in the following tabulation. These estimates are specific to the current manpower skill levels at Tracor Hydronautics and conduct of the model tests in the Hydronautics Ship Model Basin.

<u>Task</u>	<u>Man-Hours</u>	<u>Model Basin 8-Hour Shifts</u>
I	200	-
II	1000	-
III	1100	30
IV	<u>500</u>	<u>-</u>
TOTAL	2800	30

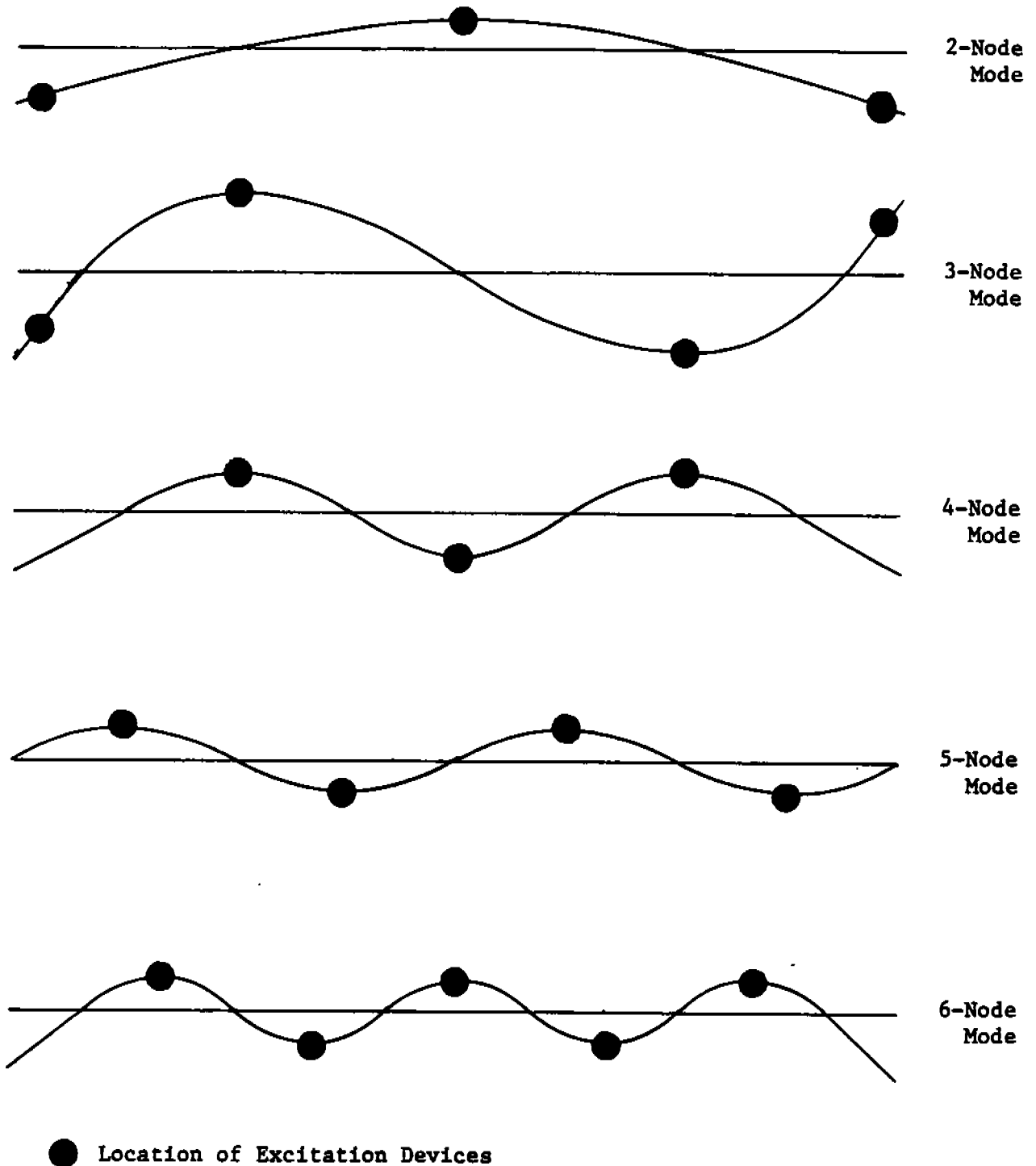

FIGURE 17 - APPROXIMATE LOCATION OF EXCITATION DEVICES

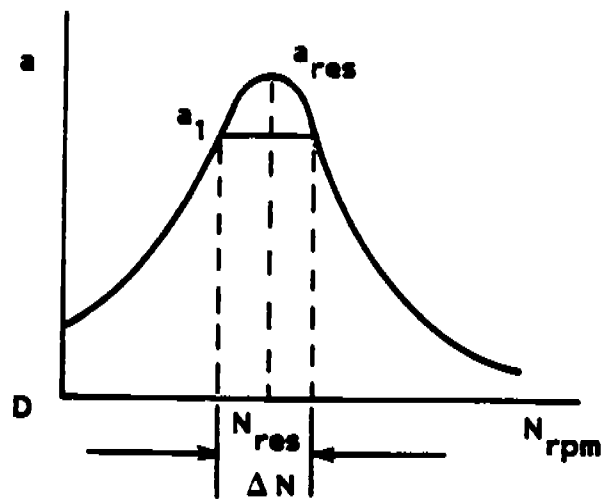

FIGURE 18 - DEFINITION OF TERMS IN EQUATION [45]

TABLE 5 - SCALING RELATIONSHIPS FOR PROTOTYPE AND MODEL

Measured Quantity	Prototype	Model
Length	L_p	$L_m = \lambda L_p$
Strain	ϵ_p	$\epsilon_m = \epsilon_p$
Stress	σ_p	$\sigma_m = e\sigma_p$
Force	F_p	$F_m = e\lambda^2 F_p$
Moment	M_p	$M_m = e\lambda^3 M_p$
Moment of Inertia	I_p	$I_m = \lambda^4 I_p$
Section Modulus	S_p	$S_m = \lambda^3 S_p$
Polar Moment of Inertia	J_p	$J_m = \lambda^4 J_p$
Torque	T_p	$T_m = e\lambda^3 T_p$
Shear	τ_p	$\tau_m = e\tau_p$
Unit Angle of Twist	θ_p	$\theta_m = \frac{e}{g} \theta_p$
Total Angle of Twist	ϕ_p	$\phi_m = \frac{e}{g} \phi_p$
Axial Deformation	δ_p	$\delta_p = \lambda \delta_p$
Mass/Length	ρ_p	$\rho_m = \lambda^2 \rho_p$
Natural Frequency	ω_p	$\omega_m^2 = \frac{\omega_p^2}{\lambda^2}$
<p>Note: In the relationships given above,</p> $\lambda = L_m/L_p$ $e = E_m/E_p$ $g = G_m/G_p$ $G = E/[2(1 + \nu)]$		

(from Reference 11)

4.0 PLAN FOR FULL-SCALE DAMPING EXPERIMENTS, PHASE III

4.1 Objectives:

4.1.1 General Considerations - The primary objective of the full scale tests is to develop data needed for vibration analysis and to correlate these data with the results of the theoretical and model work. The following basic investigations should be carried out regardless of ship type selected:

(a) Evaluation of Alternative Test Procedures and Methods of Excitation - Among the modal parameters, the damping is the most difficult to evaluate and the most sensitive to the types of excitation, test procedure, accuracy of measurements and effectiveness of the analysis method. It was shown earlier types of excitation that can be applied to a test ship are steady state, impulsive or impact, or random or pseudo-random. No method of excitation is superior in all applications. The most widely used steady state excitation provides a poor linear approximation of a nonlinear system. Impact tends to excite all non-linearities in a system, and, therefore, might not work well in a nonlinear system such as a ship hull. It will be highly desirable to determine the correlation among different types of excitation and methods of analysis and to present accurate and unbiased results for further selection or improvement.

(b) Selection of Ship Operation Conditions - The vibration tests should be conducted as ship speed is increased from zero to maximum speed, with relatively small rate of shaft rpm increase. This procedure will provide damping values for the ship underway.

(c) Selection of Cargo Loading Conditions - In order to obtain reliable damping data on cargo component, systematic experiments with different cargoes and cargo loadings, together with a variety of ship speeds and frequency conditions, should be conducted.

4.1.2 Specific Objectives - The following are specific objectives of the full-scale tests.

(a) Isolation and determination of damping components which cannot be simulated by model tests. Since the hydrodynamic damping coefficients will be determined from the model experiments, cargo and structural damping coefficients can be isolated from the total damping determined from the full-scale tests.

(b) Assessment of the accuracy and sensitivity of various techniques in order to evolve an improved method for rapid collection of reliable damping data.

(c) Assessment of the validity of calculation procedures when extrapolated from model scale.

(d) Correlation of measured responses with various existing ship vibration theories.

(e) Formulation of engineering recommendations for ship designers.

4.2 Ship Selection

4.2.1 General Considerations - The following general considerations apply to the selection of any ship and indicate compromises that may be necessary:

(a) The ship configuration must permit the carrying out of tests both at rest and underway.

(b) Some of the major hull modes (as many as possible) must be excited by the main engine and/or the propeller within the running speed range. For example, excitation by primary and secondary unbalance forces associated with a slow speed diesel engine would provide a major feature to be sought.

(c) The test schedule should provide for at least one day with the ship at rest and two or three days underway in deep water.

(d) The geographical location should provide for a reasonable certainty of good weather and convenient availability for the test crew.

(e) Operating schedule should permit conducting tests under several loading conditions.

4.2.2 Tentative Recommendations - The general decline in shipping and the stringent economic restrictions placed on ship operation are expected to greatly reduce the near term opportunities for carrying out experimental research in ships at sea. It is likely that the choice of ship will be influenced more by availability than by the suitability of purpose. Taking these factors into account, selection of a U.S. flag tank vessel is recommended for the following reasons:

(a) U.S. registered tank vessels in both commercial and U.S. government service are primarily in continental U.S. coastwise and intercoastal trade, insuring reasonable availability and access for test personnel.

(b) The nature of the tank vessel geometry and cargo handling systems are such that load and ballast conditions are readily changed and easily defined.

(c) Individual cargo tank loadings are readily changed to permit systematic investigation of cargo damping.

At the present time, economic conditions in the U.S. merchant fleet are such that tanker availability for controlled test purposes is expected to be limited. Under such adverse conditions, owners and operators are unlikely to support research programs that involve significant expense and schedule interruptions. Accordingly, at this time the selection of candidate tank vessels in Military Sealift Command service is suggested. The MSC and U.S. Navy are direct participants in the Ship Structures Committee. Relatively new product tankers are in MSC service and it is expected that availability of an appropriate MSC owned or chartered tanker could be more easily arranged than a privately owned and operated tanker.

The selection of one or two candidate classes of tankers in MSC service is suggested. The first, the twelve year old, SEALIFT class, is of conventional arrangement, with single bottom and two longitudinal bulkheads, forming three cargo tanks abreast and seven tanks along the cargo length. Principal characteristics of this class are listed:

Length, BP	560'-4"
Breadth, mld	84'-0"
Depth, mld	45'-6"
Draft, fbd, keel	34'-7"
Deadweight, total	27225 tons
Displacement, total	34000 tons

BHP, maximum continuous	14000
Service speed	15 knots

An alternative recommendation is the new class of T-5 tankers currently under construction by American Shipyards Inc. for delivery to Ocean Product Tankers, Inc., under charter to M.S.C. The design is unconventional in that a double skin bottom and side shell has been adopted, with clean ballast spaces located within the double skin tanks. Port and starboard cargo tanks are divided by a single centerline longitudinal bulkhead. While this arrangement is unconventional relative to most existing tank vessels, it is representative to some degree of characteristics of some special products carriers designed for liquefied gas and chemical cargo transport. Comparison of cargo damping effects in the T-5 and older SEALIFT classes could be particularly useful. Principal characteristics of the new T-5 design are listed:

Length, BP	587'-6"
Breadth, mld	90'
Depth, mld	53'-8"
Draft, fbd, keel	34'
Deadweight, total	30000 tons
Displacement, total	39000 tons
BHP, maximum continuous	18400
Service speed	16 knots

4.3 Measurement and Data Analysis Techniques

The specification of measurement techniques is fairly straightforward since shipboard measurements of vibration have a long history, as described in Chapter 2 and Reference 11.

Generally the primary concern is in insuring that vibration is measured under controlled conditions and that measurements are obtained under proper conditions, e.g., frequency monitoring of all signals, precise and accurate logging of the test procedures, measurement of the background noise signals, etc.

Methods of analysis of vibration tests ashore and aboard ship differ significantly because of vibrations resulting from environmental conditions. Aboard ship, predominant sources of environmental vibration result from the blade passing frequencies, flow turbulence/cavitation of the propeller, wave action and flow turbulence impinging the hull. To a lesser extent, there can also be environmental vibration induced by transmission between machinery components.

Test equipment should be designed to permit continuous monitoring and simplified analysis during or immediately after test runs to insure the proper recording of all signals throughout all tests. More precise or extensive analysis will be carried out on return to the laboratory. Continuous monitoring will provide evidence that the tests are producing the required information. It is unlikely that the tests can be repeated once the trials team has left the ship.

4.4 Excitation Devices

Rotating mass and electrohydraulic vibration generators used in vibration studies were examined in detail by Chang and Carroll in Reference 11. In recent years, two other types, impact by anchor or hammer, excitation from the engine and propeller, have been successfully used. The general capabilities of each type with regard to applicability to the

present project are briefly reviewed in the following discussion.

4.4.1 Rotating Mass Vibration Generators - This class of exciter is most widely used and produces its dynamic force from the centrifugal force of rotating unbalanced masses. Unidirectional forces and moments are obtained by unbalancing and phasing more than one rotating mass, see Figures 19 and 20. Most of the devices studied use two or three rotating masses but some, such as the Littleton Research devices, use four, eight, or twelve weights to produce a wide range of harmonic forces. Figure 20, provided by Littleton Research, shows a variation of the harmonic force as a function of the generator RPM and number of rotating weights.

Large research organizations dealing with the vibration tests usually have several harmonic exciters covering the wide range of the forces and frequencies. The British Maritime Technology (BMT) has three mechanical exciters which together cover a frequency range from 30 c/min to 1000 c/min. In the United States, the NSRDC has a wide range of these exciters, as shown in Table 6 below compiled from the information in Reference 11.

Table 6

Principal Characteristics of Some Rotating Mass Exciters

Numbers (Appeared on Figure 21) Owner	1 US NAVY	2 US NAVY	3 US NAVY	4 US NAVY	5 US NAVY	6 US NAVY
Overall Dimensions:						
Length (in.)	108	63	51	27-1/2	18-1/4	14-1/4
Width (in.)	60	12	32	7	6	5
Height (in.)	44	16	23-1/2	9-3/4	7-5/8	5-5/8
Weight (Exciter) (lbs)	12,000	2,000	729	140	77	35
Maximum Force Output (Continuous) (lbs)	40,000	5,000	10,000	8,000	4,000	2,000
Frequency Range (Hz)	0.66-20	0.42-33	0.6-50	100	100	100

Regardless of the specific mechanisms of force generation, one common feature of all devices is that the maximum force output is linearly proportional to mass (see Figure 20) and proportional to the square of the angular speed of the rotation. Figure 21, taken from Reference 11, is a plot of the maximum single amplitude force versus frequency for the devices covered by Table 6.

The advantages of these exciters are:

- (a) Mechanically robust and easily attached to the ship
- (b) Speed control allows precise examination of resonant conditions and provides force and response data amenable to mathematical analysis.

(c) Provide for experimental assessment of the damping most closely related to the theoretical analysis and model work.

(d) Damping values obtained are primarily related to the structural properties and non-structural mass of the ship at rest. The modifying factors introduced by forward speed, ship motions are absent.

The few disadvantages of these exciters are:

(a) Limited force and speed range, depending on their physical size.

(b) At low frequencies, especially as low as 1 Hz, the maximum force shown in Figure 21 is low for all devices, and as indicated in Reference 11, none are capable of producing the 20,000 lbs at 1/3 Hz required to excite the 2-node mode on such vessels as the Great Lakes ore carrier STEWART J. CORT. This limitation should be checked very carefully in regard to the selected vessel for the proposed program.

4.4.2 Hydraulic Exciters - Hydraulic exciters are an alternative source of excitation and have the advantage that the force is not a function of frequency, and, therefore, capable of producing large forces at low frequencies. This type of equipment is commercially available. Typically, these devices are rather bulky and it would be difficult to operate several units if higher modes of vibration are to be evaluated.

4.4.3 Impact Devices - Early references to methods of imparting an impact to a ship to excite its natural frequencies suggested this might be accomplished by dropping the anchor.

This may be effective but it cannot provide an accurate examination of the input force amplitude and frequency nor does it allow a convenient succession of tests. The use of hammers with a force transducer has developed from the 1/4 lb laboratory size to a 12 lb size suitable for using on shipboard. A recent paper, Reference 80, describes an impact device for ships' hulls and the effect of different hammer head materials on the force characteristics. These characteristics must be fully understood if the desired modes are to be excited adequately.

It is important that impact tests be carried out in order that the measured values can be compared with other types of excitation. If significant differences occur, the reasons should be investigated since the relationship between decay time and maximum vibration amplitude produced by a constant frequency sinusoidal force might provide useful information on the mathematical formulation of damping. It is also relevant to damping values associated with vibration induced by slamming. Slamming and the consequent vibration are not of concern in the present program but it is an important design consideration.

4.4.5 Excitation from the Propeller and/or Engine - It is important to determine the damping values pertaining to resonances excited by the engine and propeller when the ship is underway. The values can be obtained by slowly increasing the main shaft speed from zero to maximum speed. It is necessary, of course, to ensure that resonances of consequence to the overall study will be excited within this running range. Primary and secondary unbalance of particular diesel engines usually provide adequate excitation of major hull modes. It is important to note that comparison of damping values for a

particular mode obtained from excitation associated with both primary and secondary unbalance forces may reveal differences due either to forward speed or a dependence of the damping value on the amplitude of vibration. This could be resolved by conducting mechanical exciter tests with two different force magnitudes.

4.5 Location and Magnitude of the Excitation

As previously discussed in reference to the model tests, the location and magnitude of the excitation device is determined by the system characteristics. See Equation [44]. The basic concept is to select excitation by maximizing the main frequency and minimizing the contributions of "off-frequencies." Figure 17 shows the approximate locations of the excitation devices to achieve the conditions imposed by Equations [44]. At higher modes as many as five excitation devices could be needed. A full-scale vessel is not uniform along the length, so the location of the nodes are only approximate. On ship trials, location and magnitude of the excitation should be estimated accurately. Excitation devices should be mounted on special foundations and should be attached to major structural elements.

Sinusoidal excitation tests can be carried out in about 1-1/2 to 2 hours. Consequently several tests can be completed within a day, thus providing some measure of repeatability and correction of experimental error. It is possible to carry out tests while the ship is underway. At slow speeds in still water it may be possible to detect the effect of forward speed. It is suggested, however, that this could be a difficult test to undertake and might yield results of little value unless theory and model experiments indicate that damping is very sensitive to forward speed.

4.6 Measuring and Recording Instrumentation

There is a wide range of commercially available measuring and recording instrumentation appropriate to shipboard vibration measurements. Most research organizations with sufficient experience to carry out the tests will possess equipment which will be adequate for the purpose of measuring ship vibration e.g., accelerometers, amplifiers, wave analysers and magnetic tape recorders. However, there are several features peculiar to the measurement of vibration for the purpose of determining damping value which need consideration, including the following:

4.6.1 As suggested earlier, it is important to be able to conduct some analysis of the measurements as the test progresses. Since the tests involve impact methods and, thus, transient signals, it is necessary to have on board an FFT realtime analyser, preferably a multi-channel Micromodal Analyser, which can carry out modal analysis and provide damping values from each of several impacts. Apart from this ability, such analysers will be able to provide the experimenter with an immediate indication of the validity of the measurement and that correct and complete data has been acquired.

4.6.2 The range of vibration amplitudes to be measured accurately during both impact excitation and sinusoidal excitation will extend over perhaps three orders of magnitude. In order to retain comparable accuracy at both ends of the amplitude scale the recording system must have a wide dynamic range. There are now commercially available digital tape recorders which have a wide effective dynamic range.

4.6.3 The instrumentation should include analog magnetic tape recorders. Firstly, they can provide a useful back-up facility. Secondly, recordings made of the tests involving engine and propeller excitation can be easily dubbed, and analysed on an analogue system, such as the General Dynamics Spectral Analyser. While digital analysis is generally more rapid and provides more precise data, the analogue analysis process can be conditioned to reveal the nature of the conditions prevailing throughout the test duration, e.g. rapid changes in shaft speed, effect of ship pitching or rolling, signal faults, etc.

4.6.4 As suggested earlier, all full-scale tests should employ a fairly large array of pick-ups in order to define mode shapes and to indicate the degree of coupling or the degree of 3 dimensionality. The variation in damping along the hull can be determined by selectively obtaining values from any or all of these pick-ups.

4.6.5 Factors such as robustness in transit, reliability, ease of repair and convenience in use should not be ignored. Special requirements, such as the use of intrinsically safe equipment in tankers, must be recognized.

4.7 Analysis of Test Data

The analysis of test data requires careful study. In general the results of impact tests are probably best treated by parameter identification using curve fitting techniques, either already programmed in the FFT analyser or enhanced techniques specially developed for the purpose.

The sinusoidal force excitation and excitation by main engine or propeller are probably best treated by using techniques discussed in model test analysis. Damping identification methods available today were discussed in Chapter 2. In preparation of the full-scale vibration tests, they should be reviewed thoroughly and the most promising and appropriate techniques should be selected. In pursuing this program it should be noted that the main characteristics of ship vibration are:

a) Frequencies are generally less than 15 Hz.

b) Although lower main hull modes are assumed to be two dimensional, i.e. they are considered as vertical, horizontal or torsional modes, this assumption is valid only for very low modes. The frequency at which this assumption becomes invalid depends generally on the geometry of the ship.

c) Vibration data obtained during the test is "noisy". Apart, from instrumentation noise which can be assessed, noise is generated from many sources. The effect of small variations in engine speed is one factor. The random force input from the sea, in all but still water, calm, conditions, is another since this force is not considered in the calculation of transfer functions. In these circumstances, any techniques which are directed to the reduction of noise should be given attention. This is particularly important as "noise" reduces the sensitivity of the analysis and may obscure actual measurements. For instance, slight distortion of a polar diagram of the sort shown in Figure 2 could indicate non-linearity in the damping or the presence of coupled modes. Tracor Hydronautics has developed several efficient filtering techniques with minimal disturbance of the energy content of

the record. Figure 1 in Appendix A shows the unfiltering recording of acceleration (excitation test) and Figures 2 and 3, respectively, show the result of the application of the so-called "moving average filter" (MA) and combined results applying MA and conventional RC, low-pass filters together.

(d) Response and Bending Moments Measurements

The measurements and damping coefficient estimates based on bending moment measurements are similar to the model test measurements and consist of the following main steps:

- Determine the first ten natural frequencies of the ship.
- Excite the hull with enough force for reliable measurements of displacements and/or bending moments,
- For steady state or transient excitations measure accelerations along the hull and obtain deflection and velocity curves by numerical integration,
- Measure the bending and shear stress along the hull,
- Filter the measured displacement (or moment) into curves associated with different modes,
- Estimate ship damping.

4.8 Full-Scale Test Parameters

4.8.1 Load and Ballast Distribution Variation - The variation in damping values for variation in loading conditions

is one of the primary investigations required. Full-scale test conditions can be obtained most readily by varying liquid cargo and water ballast loading conditions of a tank vessel. The test must be well defined since some earlier vibration studies indicate that non-uniform distribution of ballast distorts hull modes and damping values for particular modes. Because loading will alter the natural frequencies, it is unlikely that all the modes of interest will be excited by the engine or propeller in all loading conditions and the overall comparison will probably be made on the basis of mechanical exciter tests. Results of prior mode tests should be used to determine the best selection of full-scale test conditions to minimize costs.

As suggested above, the mass distribution relative to the mode shape appears to have a significant effect and should be examined. Initial controlled experiments are best carried out on models, with full-scale supporting evidence obtained as opportunity arises.

4.8.2 Cargo Characteristics and Distribution - The effect of cargo characteristics might be examined by carrying out tests on a ship which under, regular operations, carries widely different cargoes. For example an O-B-O may transport dry bulk cargoes and liquid bulk cargoes at different times during the life cycle of the ship. Similarly, a "con-bulker" may transport dry bulk cargoes outboard and containers on the backhaul voyage. Model tests can provide a useful guidance. It is acknowledged, however, that full-scale tests may well be difficult to arrange for the alternative cargo cases.

4.8.3 Ship Speed and Water Depth Variation - These are both fundamental variables and must be covered. As with several of the other tests they can be restricted to the

minimum required to relate to model tests, e.g. water depth variation requires only one test in deep water and one test in shallow water.

4.8.4 Effects of Operating History - The comparison of damping values determined for sister ships should be considered. If the ships are in the same condition i.e. draught, depth of water, age then they should have the same damping values. If the damping is significantly different and the reason cannot be determined the validity of the project as a whole becomes questionable. Obviously great care must be taken to insure that both the subject ships and the measurement techniques are very similar. Tests will have to be conducted with the ship stationary in still water because other modifying factors, e.g. sea state, motions, engine speed control cannot be exactly reproduced for both ships.

There is some evidence that damping might be effected by the ship operating history. Changes might occur because damping changes over a short period follow major changes of stress in the structure, e.g. after loading or discharging cargo. These effects should be considered during the conduct of model experiments.

4.9 Summary of Full Scale Test Program

In order to achieve the objectives of Phase III program the following experimental program is recommended. Variation of forward speed will be defined following the analytical and model test investigation in Phase II.

1. Select the representative ship and sites for the full-scale trials.

2. Specify ship operational condition, structural system, cargo loading conditions and anticipated environmental conditions for the selected vessel.

3. Specify testing methodology, type of measurement and analysis on board and ashore.

4. Select the suitable test equipment, instrumentation, and data recording equipment.

5. Specify required excitation devices, location on the ship and analysis techniques to determine damping coefficients.

6. Conduct vibration tests for zero and forward speed, with and without cargo. Vary the cargo type, if appropriate, and distribution along the hull. Determine modal parameters, e.g. frequencies and damping coefficients.

7. Conduct vibration tests for in ballast condition at zero and forward speed. Determine resonance frequencies and damping coefficients.

8. Conduct vibration tests at intermediate draft for representative speed cases and cargo loadings. Determine resonance frequencies and damping.

9. Based on the results obtained in Tasks (6), (7), and (8) determine cargo damping for different loading conditions at full load and ballast conditions.

10. Conduct vibration tests of the vessel at operating draft for different environmental conditions, e.g., in waves, in shallow water, and with different types of excitation and

damping identification methods. Determine damping and measure the main hull responses.

11. Conduct selected vibration tests of a sister ship at operating draft, if available.

12. Using the magnitude of the hydrodynamic damping determined in Phase II and value of cargo damping as estimated in step 9, determine the structural damping from the total vibration damping. Assess the structural damping as a function of the following parameters:

- Vibration modes variation
- Load distribution variation
- Local structural effects and variation of damping along the hull
- Effect of different types of excitation and analysis techniques
- Non-linear effects and variation of damping of amplitudes of vibration response.

13. Conduct comparisons between calculated and measured ship responses, bending moments, accelerations, etc. for representative conditions in time/frequency domain using standard engineering methods and advances finite element methods.

14. Develop ship design recommendations.

The essential information required by the designer, and a primary objective of the program, include the following:

(a) The significance of damping values in the prediction of vibration amplitudes of the ship to be designed. If natural frequencies will not be excited by the sources of excitation, within the operating range of the ship, precise damping values are of little concern.

(b) Graphical presentation, or simple calculation methods which will provide damping values appropriate to the ship.

(c) Some indication of the accuracy and reliability of the values obtained from (2).

(d) Qualifications on the values e.g. modifying effects of cargo types, sea state, depth of water, etc., which might be crucial to his design decisions.

4.10 Work Scope

The 14 program events listed above are combined in the following four tasks. Estimated professional manpower level of effort is given for each task. These estimates apply only to the test and experimental staff and do not include ship's crew and shore support requirements for normal ship operations.

Task 1: Assessment of full-scale testing techniques.
Selection of ship, instrumentation and analysis procedures.

- 1.1 Assess suitability of existing techniques for the project objectives and select the best approach.
- 1.2 Define conditions for conducting full scale testing. Select vessels, exciters, and corresponding instrumentation.

Task 2: Full-scale testing

- 2.1 Test and calibrate instrumentation.
- 2.2 Specify test procedures and schedule.
- 2.3 Conduct full scale tests for selected conditions.
- 2.4 Prepare preliminary assessment of the data with respect to suitability for the damping analysis.

Task 3: Analyses of measured data

- 3.1 Prepare raw data analysis, including filtering and noise reduction.
- 3.2 Prepare frequency response analysis of the data for the specified conditions.
- 3.3 Isolate and determine damping components as a function of modes of vibration, ship hull flexibility, and load distribution.

Task 4: Verification of the calculated and tested results.

Engineering recommendations for ship designers

- 4.1 Determine and assess the different components of vibration damping.
- 4.2 Assess effects on damping of excitation, material properties, water depth, and ship speed.

- 4.3 Assess effects of local deformation, viscosity and other non-linear effects on correlation of computations and tests.
- 4.4 Assess effects of limitations of existing theoretical and computational methods for estimating vibration damping.
- 4.5 Analyze damping data for engineering applications in ship design.
- 4.6 Prepare final technical report.

The projected work plan and schedule for each task of Phase III effort, combined with the preceding Phase II, are shown in Figure 22. Duration of the Phase III is planned to be 14 months.

Estimated manpower requirements for each of the four tasks are given in the following tabulation. The estimates apply only to contract engineers and technicians and exclude assistance of shipboard personnel.

<u>Task</u>	<u>Man-Hours</u>
1.0	
1.1	60
1.2	100
2.0	
2.1	200
2.2	150
2.3	400
2.4	250

3.0	
3.1	200
3.2	200
3.3	600
4.0	
4.1	200
4.2	100
4.3	100
4.4	100
4.5	100
4.6	140
Total	2900

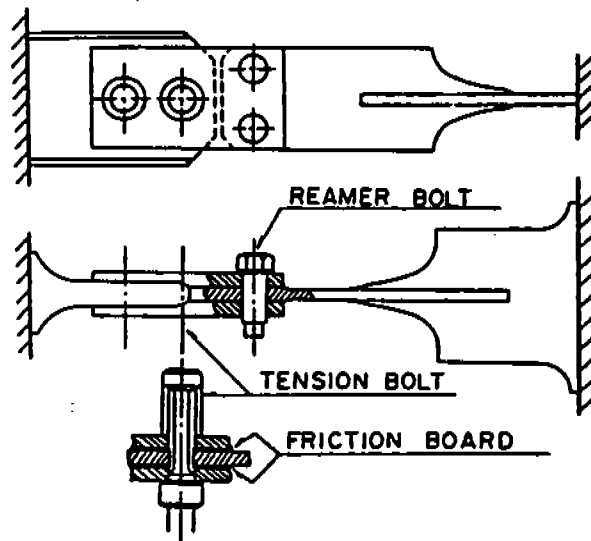
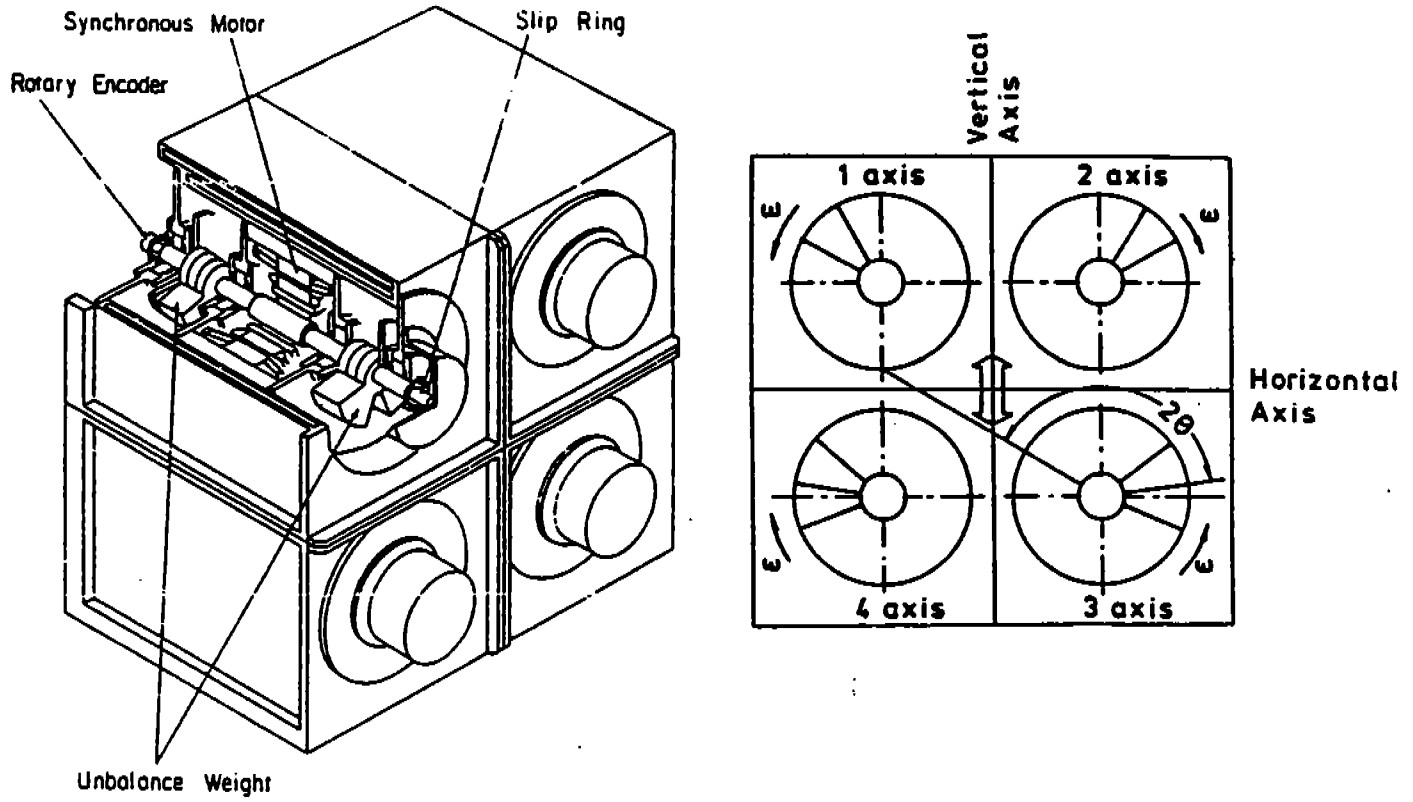

FIGURE 19 - NEW TYPE OF EXCITER (REF. 8)

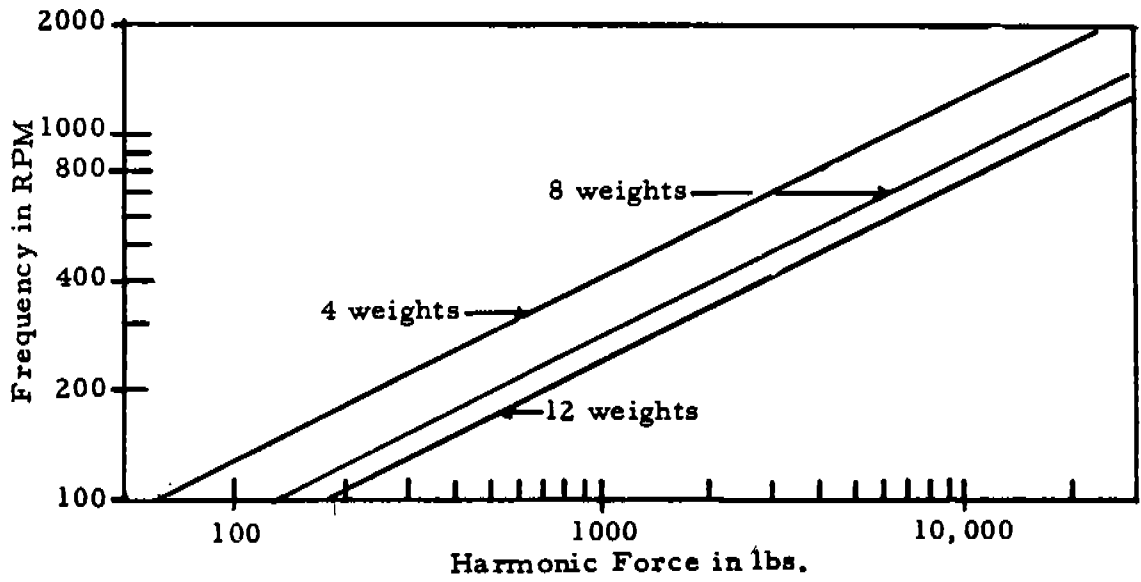

FIGURE 20 - VARIATION OF THE HARMONIC FORCE VERSUS RPM FOR LITTLETON RESEARCH GENERATOR

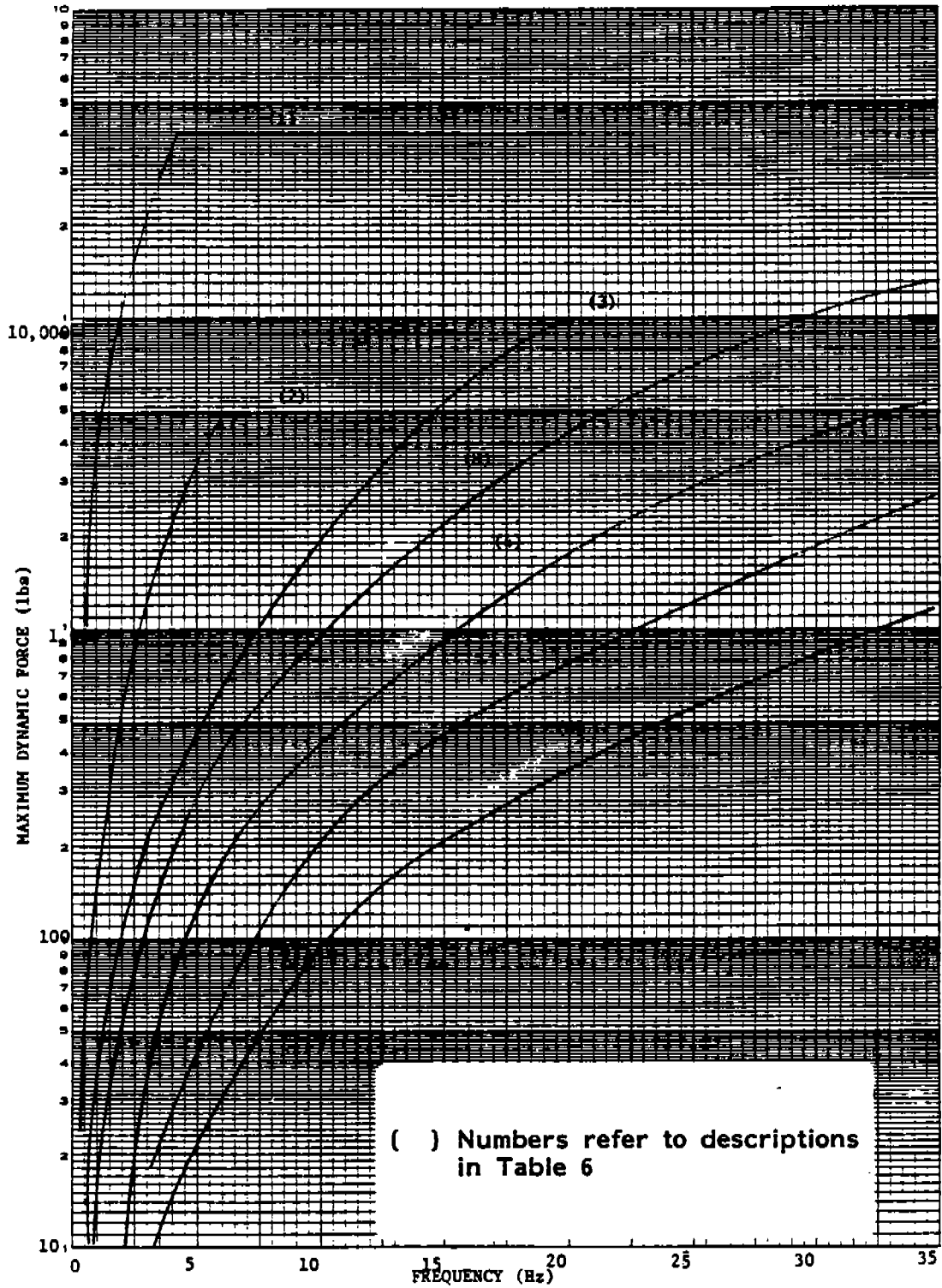
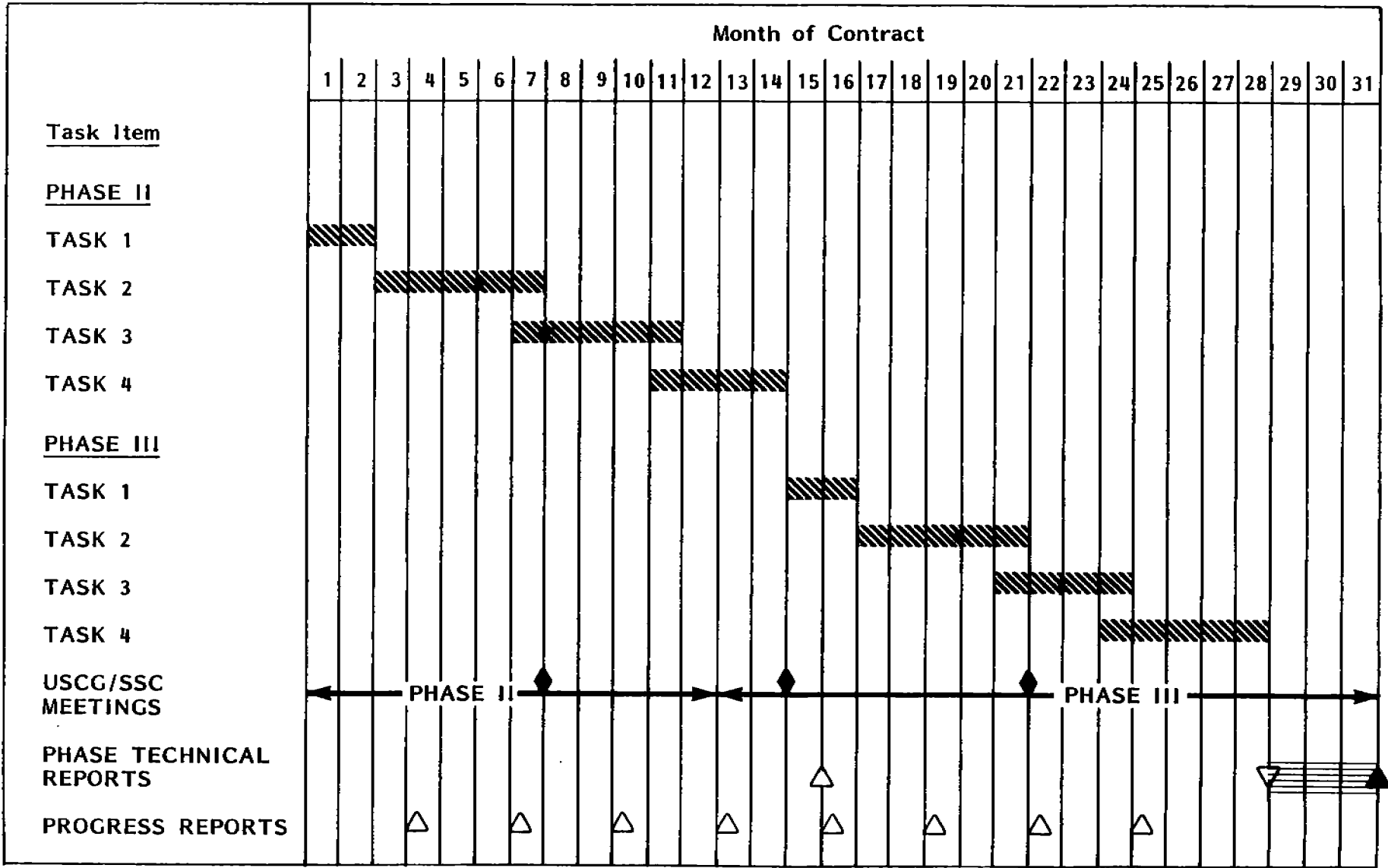

FIGURE 21 - ROTATING MASS VIBRATION GENERATORS MAXIMUM PEAK DYNAMIC FORCE OUTPUT VS. FREQUENCY



▽ SUBMITTAL OF DRAFT REPORT
▲ FINAL SUBMITTAL OF REPORT
≡≡≡≡ U.S.C.G. REVIEW OF REPORT

FIGURE 22 - PROJECTED WORK PLAN AND SCHEDULE

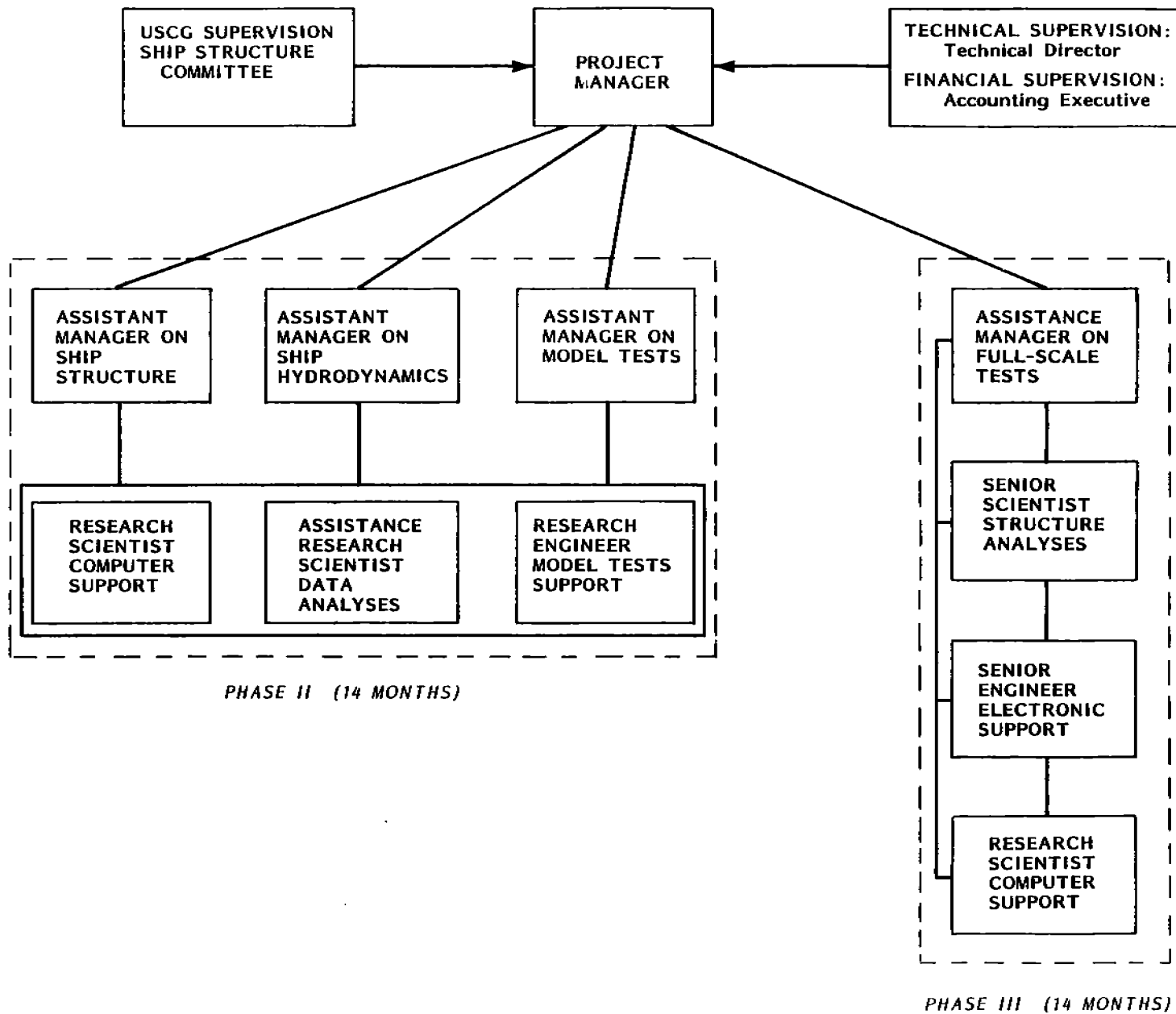

FIGURE 23 - PROPOSED PROJECT ORGANIZATION

REFERENCES

1. "Report on Ship Vibration Symposium 78", Ship Structure Committee Report, 292, 1979.
2. Noonan, E.F. and Feldman, S., "State of the Art for Shipboard Vibration and Noise Control", Proceedings of Ship Vibration Symposium, Arlington, VA, October 1978.
3. Chang, P.Y., "Fatigue Life and Causes of Failure of Sonar Dome Rubber Window Cover," Hydronautics, Inc. Report No. 8210.191, March 1983.
4. Jensen, T.T., and Madsen, N.F., "A Review of Ship Hull Vibration," The Shock and Vibration Digest, April, May, June, July, 1977.
5. Volcy, G.C., Baudin, M., "Integrated Treatment of Static and Vibratory Behavior of Twin-Screw 553,000 DWT Tankers", Transactions, RINA, 1978.
6. Proceedings of the 8th International Ship Structure Congress, 1982.
7. Proceedings of the Ship Structural Symposium 84, Washington, D.C., October 15-16, 1984.
8. Proceedings of the 9th International Ship Structure Congress, Genova, 1985.
9. D. Catley, and C. Norris, "Theoretical Prediction of the Vertical Dynamic Response of Ship Structures Using Finite Elements and Correlation with Ship Mobility Measurements," BSRA Technical Memorandum No. 492, 1976.
10. Kaube, K., et al; "Zulassige Schwingungen on Board Von Schiffen", BMFT, Forschungsvorhaben MTK 0058 KGermanischer Lloyd's Report STB-465, 1977-79.

12. Camisetti, C., Maltese R., Scavia F., "Identification Procedures of the Model Parameters from Full Scale Measurements; Some Aspects of the Application to Ship Vibration", Paper No. 19, International, Symposium on Ship Vibrations, Genoa, May 1984.
13. Betts, C.V., "On the Damping of Ship Hulls", M. Phil, Thesis, London University, 1985.
14. Betts, C.V., Bishop, R.E.D., and Price, W.G., "A Survey of Internal Hull Damping, Transactions, RINA, 1976.
15. Armand, T.L., Orsero, P., "Analytical Identification of Damping in Ship Vibrations from Full-Scale Measurements", Paper No. 14, RINA Symposium on Propeller Induced Ship Vibration, London, December 1979.
16. Pisarenko, G.T., "Energy Dissipation During Mechanical Vibrations:", Kiev, Academy of Sciences of the Ukrainian Republic, 1962 (in Russian).
17. Akulaev, V.S., Karasik, L.F., Lentiakov, U.G., and Shavrov, Yu. N., "On the Physical Nature of Dissipative Forces Arising During Vibration of Ships," Energy Dissipation During Vibrations of Elastic Systems, Collected Articles, Kiev, Academy of Sciences of the Ukrainian SSR, 1963 (in Russian).
18. Beards, C.F., "Damping in Structures", Noise Vibration Control, 15, (6), 1984.
19. Beards, C.F. "Damping in Structural Joints", the Shock and Vibration Digest, Volume 17, No. 11, November 1985.
20. Armand, T.L., Orsero P., Robert, O., " Dynamic Analysis of the Atterbody of a Ship - Towards a Successful Correlation Between Analytical and Experimental Results", Proceedings, Ship Vibration Symposium 1978.
21. Hayes, M.N., "Parameters Identification of Non-Linear Stochastic System Applied to Ocean Vehicle Dynamics", MIT Ph.d Thesis, Department of Ocean Engineering, 1976.
22. Hwang, W.V., "Application of System Identification to Ship Maneuvering, " MIT, Ph.D. Thesis, Dept. of Ocean Engineering, 1980.

23. Armand, T.L, Orsero P., "Analytical Identification of Damping in Ship Vibrations from Full-Scale Measurements," Paper No. 14, RINA Symposium on Propeller Induced Ship Vibration", London, December 1979.
24. Woolam, W.E., "A Review of the State-of-the-Art of Vibration Damping Associated with Ship Hull Structure", Technical Report No. 1, DTMB, February 1965.
25. Woolam, W.E., "Analysis of Methods for Computing and Measuring Vibration Damping Characteristics of Ship Hull Structures", Technical Report, No. 2, June 1965.
26. "Description and Instruction Manual of the Littleton Research Harmonic Force Generator", Private Communication with F. Everett Reed of the Littleton Research and Engineering Corporation.
27. Hara, T., Obtaka K., Kagawa, K., "On the Application of Impulse Test Method to Ship Vibration", 3rd International Congress on Marine Technology, Session 8, Athens, 1985.
28. Foster, W.P. and Alwa H.F., "Damping Values of Naval Ships Obtained from Impulse Loadings", Search and Vibration Bulletin NO. 40, December 1969.
29. Brown, D., Carbon, G., Ramsey K.", Survey of Excitation Techniques Applicable to the Testing of Automotive Structures", Int. Automotive Engineering Congress, Detroit, 1977.
30. Buchanan, E., and R.G., Ruckerman, "Model Basin Procedure for the Analysis and Presentation of Vibration Data," Shock, Vibration and Associated Environments. Bulletin No. 33, February 1964.
31. Beals, V.L. and Hurley, S.R., "The Application of Impulsive Excitation to In-Flight Vibration Testing," Aerospace Engineering 20, No. 1, January 1961.
32. Campbell, R.B., Vandiver, J.K.: "The Determination of Model Damping Ratios from Maximum Entropy Spectral Estimates", ASME Winter Annual Meeting, Paper No. 80, WA/DSC-29, Chicago, Ill., November 1980.

33. Briggs, M.J. and Vandiver J.K.: "Multichannel Maximum Entropy Method of Spectral Analysis Applied to Offshore Platforms", OTC Paper 4268, Houston, 1982.
34. Prevosto, M., Barnouin B. and Hoen C.: "Frequency Versus Time Domain Identification of Complex Structures Modal Shapes Under Natural Excitation", IFIP Congress, Copenhagen, 1983.
35. Ward, G., Willshare G.T., "Propeller Excited Vibration with Particular Reference to Full-Scale Measurements," Transactions, RINA, Vol. 18, 1976.
36. Volcy, G.C., Baudin M., Morel P.: "L'Amortissement dan les Vibrations des Navires", Nouveautes Techniques Maritimes, 1978.
37. Fujii, K., Tamida K.", "Measurements of Ship Vibration and Anti-vibration Design", Proceedings, ICCAS 1982, pp. 13-23.
38. Code for Shipboard Vibration Measurement, C-1, SNAME, 1976. Code for Shipboard Local Structure and Machinery Vibration Measurements, C-4, SNAME, 1976.
39. Arai, M., "Experimental and Numerical Studies of Sloshing Pressure in Liquid Cargo Tanks", Journal SNAJ, No. 155, 1984.
40. Van den Bosch, J.J., and J.H. Vugts, "Roll Damping by Free Surface Tanks", Netherlands Ship Research Centre, Shipbuilding Dept., Report 835, 1966.
41. Mikelis, N.E., J.K. Miller and K.V. Taylor, "Sloshing in Partially Filled Liquid Tanks and its Effect on Ship Motions: Numerical Simulation and Experimental Verification", Paper No. 7, RINA Spring Meeting, 1984.
42. Bourianoff, G., and Penumalli, B., "Computational Prediction of Ship Motion in Confined Waters Using inertial Marker Particles, Phase 1", Vol. I and II, 1977-1978, NTIS No. PB84-159797.
43. Hunt, B., "Numerical Methods in Applied Fluid Dynamics," Academic Press, London, 1982.

44. Officer, M.J., Verugdenhil, C.B., and Wind, H.G., "Applications in Hydraulics of Numerical Solutions of the Navier-Stokes Equation", Recent Advances in Numerical Fluid Dynamics, Vol. V; 1985, Editor C. Taylor.
45. Brebbia, C.A. (Editor), "Finite Element Systems", Publisher Springer Verlag, 1982.
46. Dowell, E.R., "The Behaviour of a Linear, Damped Modal System with a Non Linear Spring-Mass-Dry Friction Damper Attached", T. Sound, Vibration, 89 (1), pp. 65-84, 1985.
47. Shah, V.N. and Gilmore, C.B., "Dynamic Analysis of a Structure with Coulomb Friction", ASME Conference, Orlando, FL., Paper 82-PVP-18, 1982.
48. Mansour, A.E., Thayambolli, A., "Computer-Aided Preliminary Ship Structural Design," SSC Report-302, 1981.
49. Hughes, Owen, "Ship Structural Design, A Rationally-Based, Computer-Aided Optimization Approach, A Wiley-Interscience Publication, 1983.
50. Suhir, E. "Shock-Excited Vibrations with Applications to the Slamming Response of a Flexible Ship to a Regular Wave Pocket", Journal of Ship Research, Vol. 26, No. 4, 1982.
51. Jensen, T.T., "Beam Models for Ship Hull Vibration Analysis", The Shock and Vibration Digest, Vol. 15, No. 2, 1983.
52. Jensen, T.T., and Pedersen, P.T., "Recent Advances in Beam Models Used for Ship Hull Vibration Analysis", International Symposium on Ship Vibrations, Organized by CETENA, Genoa, Italy, May 1984.
53. Kumai, T. "Damping Factors in Higher Modes of Ship Vibrations," European Shipbuilding, Vol. 111, 1, 1958.
54. Achtazides, T. and Hseues, E. "New Formulae Predicting the Two-Mode Vertical Vibration Frequency of Ships," 3rd International Congress on Marine Technology, Athens, May, 1984.

55. Chang, P.Y., "The Effects of Varying Hull Proportions and Hull Materials on Hull Flexibility, Bending and Vibrating Stresses", SSC Report No. 288, 1979.
56. Noor, A.K., "Survey of Computer Programs for Solution of Nonlinear Structural and Solid Mechanics Problems," Computers and Structures, Vol. 13, pp. 425-465, 1981.
57. Mackerle, T., "Review of Pre and Post Processor Programs Included in the Major Commercial General Purpose Finite Element Package", Advances in Engineering Software, Vol. 5, N1, 1983.
58. Rogallo, and Parvismain, "Numerical Simulation of Turbulent Flow", Annual Review of Fluid Mechanics, Vol. 16, 1984.
59. Huse, E., Guogiang, W., "Cavitation - Induced Excitation Forces on the Hull", Transactions, SNAME, Vol. 90, 1982.
60. Strangen, J.G., "Propeller and Wave-Induced Hull Structure Vibrations", Ship Vibration Symposium Proceedings, 1978.
61. Goodman, R.A., "Wave-Excited Main Hull Vibration in Large Tankers and Bulk Carriers", Transactions, RINA, 1977.
62. Gerristma, T. Beukelman, W., Glansdorp, C.C., "The Effects of Beam on the Hydrodynamic Characteristics of Ship Hulls", 14th Symposium on Naval Hydrodynamics, Boston, 1974.
63. Salvesen, N., Tuck, E.O., and Faltinsen, O., "Ship Motions and Sea Loads", Transactions, SNAME, Vol. 78, 1970.
64. Suhir, E.L., "Response Functions for Heave, Pitch and Wave Induced Bending Moments for Flexible Ships," Transactions of Soviet Register of Shipping, Leningrad, 1978.
65. Kim, C.H., Chen, F.S., and Tien, D., "Motions and Hydrodynamic Loads of a Ship Advancing in Oblique Waves," Transactions of SNAME, Vol. 88, 1980.
66. Vorus, W.S. and Hyllarides, S., "Hydrodynamic Added-Mass Matrix of Vibrating Ship Based on a Distribution of Hull Surface Sources," Transactions of SNAME, Vol. 89, 1981.

67. Schmitke, R., "Ship Sway, Roll and Yaw Motion in Oblique Seas, SNAME, Vol. 86, 1978.
68. Ankudinov, V., "Simulations Analysis of Ship Motions in Waves", International Workshop on Ship and Platform Motions, Berkeley, October, 1983.
69. Kaplan, P. Tiang, C.W. and Bentson, T., "Hydrodynamic Analysis of Barge-Platform Systems in Waves", Naval Architect, July, 1983.
70. Chang, M.S., "Computations of Three-Dimensional Ship Motions with Forward Speed," 25th International Symposium on Numerical Hydrodynamics, 1977.
71. Inglis, R.B., and Price, W.G.", "A Three Dimensional Ship Motion Theory: Calculations of Wave Loading and Responses with Forward Speed", RINA Supplementary Papers, Vol. 124, July, 1982.
72. Proceedings of 16th International Congress of Theoretical and Applied Mechanics, Lyngby, Denmark, Aug. 19-25, 1984.
73. Jensen, J. and Tendrup-Pedersen, P., "Wave-Induced Bending Moments in Ships - A Quadratic Theory," Transactions, RINA, Vol. 120, 1978, pp. 151-165.
74. Chang, S.L., Schroeder, E.A., Wybramiec, "Structural Seaworthiness Digital Computer Program ROSAS", NSRDC Report 77-0001, 1977.
75. Belik, O., Bishop, R.E.D., and Price, W.G., "On the Slamming REsponse of Ships to Regular Head Waves", Transactions, RINA, Vol. 122, 1980, pp. 325-337.
76. Numerical Hydrodynamic Symposium, National Academy of Sciences, Washington, D.C., 1985 (Preprints).
77. Belytscko, T., and Hughes, T.D.R., "Computational Methods for Transient Analysis", Elsevier Science Publishers B.V., 1983.
78. Transactions of the Scientific and Technical Conference on the Damping of Vibrations, Defense Documentation Center, Foreign Technology Division, March 1966.

79. Nashif, A., Jones, D., Henderson, T., "Vibration Damping",
John Wiley & Sons, Inc., New York, 1985.
80. Hara, T. Obtaka, R., Kagawa, K., "International Maritime
Association Congress on Marine Technology,"
Proceedings, Athens, 1984.

APPENDIX A

EXAMPLES OF SOME TEST ANALYSIS TECHNIQUES
AND MEASURING EQUIPMENT

Test 5017, F=1.88 Hz, T=1000 lbs.
Sample Freq=100 Hz

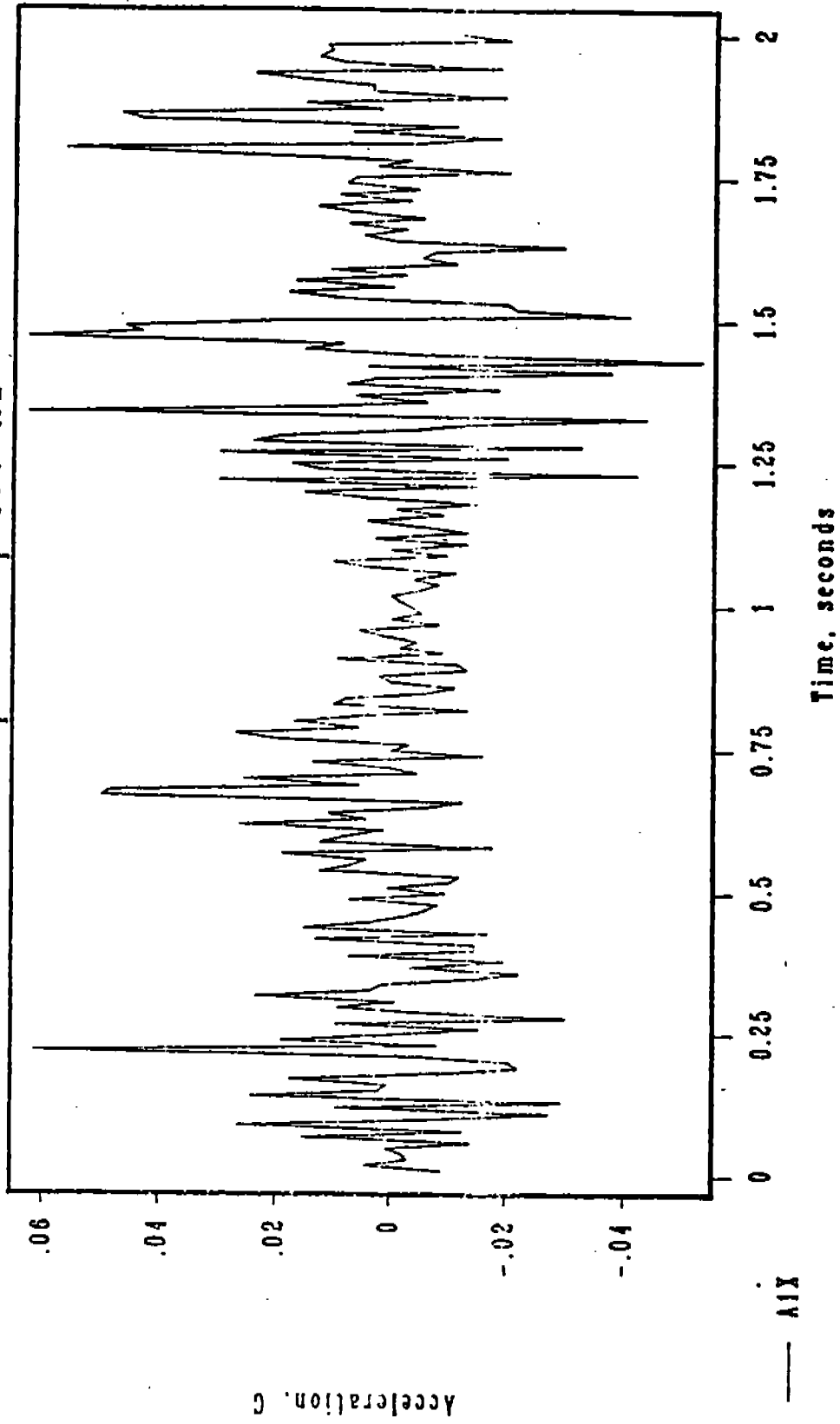

FIGURE 1 - UNFILTERED EXPERIMENTAL DATA

Test 5017, F=1.88 Hz, T=1000 lbs.
Sample Freq=100 Hz Moving average filter

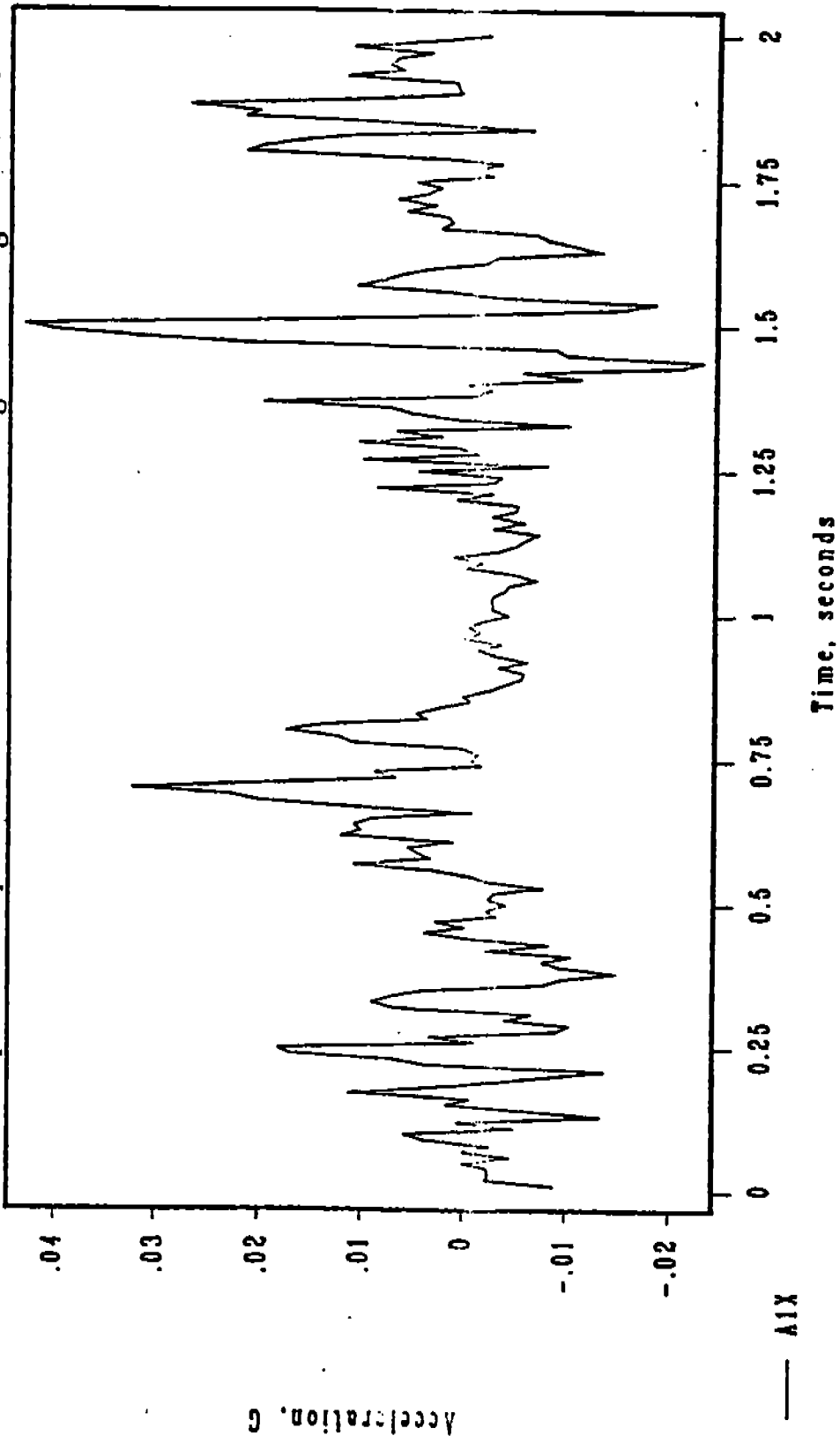

FIGURE 2 - FILTERED RESULTS WITH MOVING AVERAGE FILTER (MA)

Test 5017, F=1.88 Hz, T=1000 lbs.
Sample Freq=100 Hz MA then RC filter

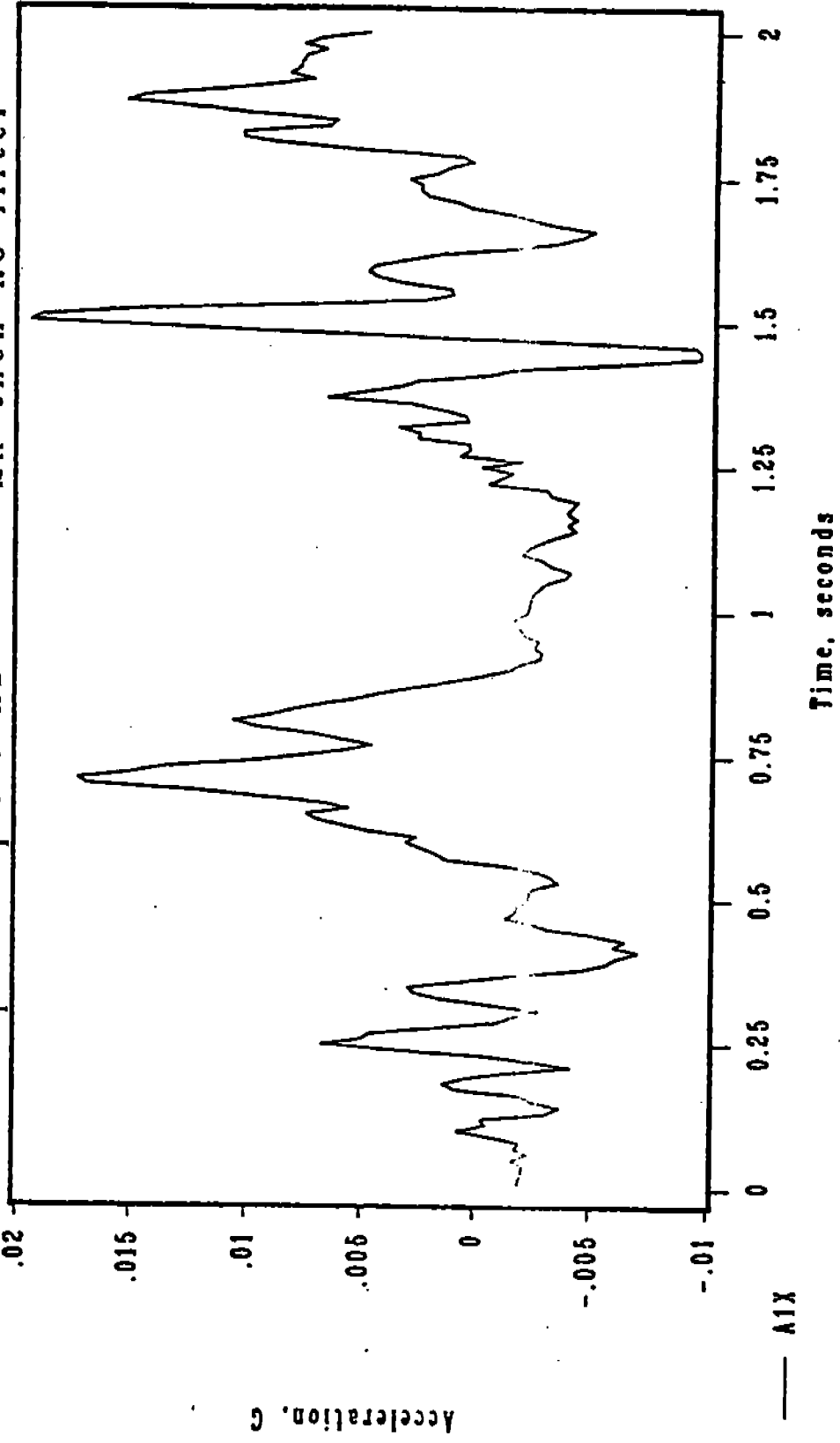
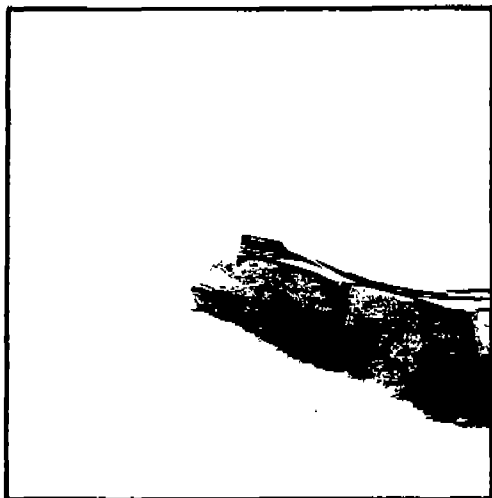

FIGURE 3 - FILTERED RESULTS WITH MOVING AVERAGE FILTER AND RC LOWPASS FILTER



EGA-125 Series Miniature Accelerometers

- 5g TO 5000g RANGES
- TO 250 mV FULL SCALE
- VARIETY OF MOUNTINGS – SMALL SIZE & WEIGHT
- STEADY STATE AND DYNAMIC RESPONSE

Entran's EGA-125 Series accelerometers are a state of the art achievement in miniature accelerometer design. Developed with the user in mind, the EGA offers an optimum combination of characteristics which permit acceleration, vibration and shock measurements where small size and mass are of prime importance.

The EGA's rugged construction eliminates the fragility normally associated with miniature accelerometers. Entran's EGA is offered in a variety of mounting styles to allow ease of handling and mounting. This mounting versatility is well suited to meet most requirements from aerospace to industrial usage and is available at no extra charge. 0.7cr damping is also available as an option.

The EGA-125 is a piezoresistive accelerometer which com-

bines a fully active semiconductor Wheatstone bridge with the technology of sensor design. Its high output enables the EGA to drive most recorders and data monitoring systems directly, without amplification or costly signal conditioning. The semiconductor circuitry is fully compensated for temperature changes in the environment and possesses excellent thermal characteristics.

The EGA-125 is functional from steady state to high dynamic responses and is ranged for "g" loads which are commonly experienced in research, testing, and control. Available in "g" ranges from 5g to 5000g. Entran's EGA miniature accelerometer is well suited for a myriad of applications from aerospace to consumer industries. Typical applications vary in scope from flutter testing to wind tunnel models to vibratory and shock disturbances in industrial testing.

GRAM RANGE FORCE TRANSDUCERS

AC OR DC-OPERATED
LINEAR VARIABLE DIFFERENTIAL TRANSFORMER TYPE

RANGES

Ten models available from ± 10 grams to ± 100 Kg (tension or compression)

EXCEPTIONAL PERFORMANCE

Reduced sensitivity to side loading, appreciable overload capacity, and high accuracy force measurement even in low gram ranges

OVERLOAD CAPACITY

Mechanical stops are available to prevent damage or calibration shifts from large overloads in both directions for the 10 gram to 1Kg ranges

TARE OR ZERO ADJUST

Mechanical zero adjust tares out relatively large pre-loads. Cell can be re-zeroed for operation with any pre-load position on the cell within its linear range.

ENVIRONMENTAL RESISTANCE

Can be designed to withstand exposure to temperature extremes, high humidity and high nuclear radiation levels. Consult factory for critical applications.

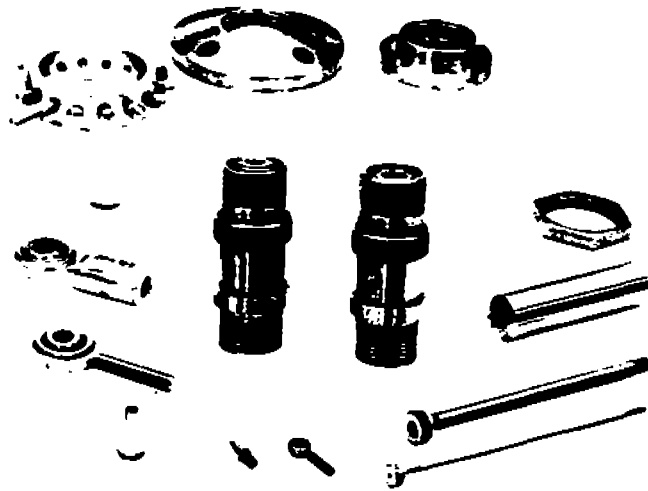

Series G Force Transducers shown with various end adaptors and load fittings.

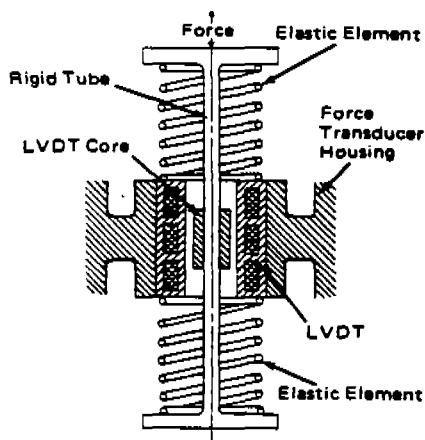

SCHMATIC DIAGRAM
GRAM RANGE FORCE TRANSDUCER

The Schaevitz G Series Force Transducer is a rugged device, yet capable of accurately measuring forces as low as ± 10 grams full range. It contains an LVDT whose core is directly coupled to two conservatively stressed elastic elements. When these elastic elements are loaded, a small linear deflection of the LVDT core results, and the LVDT produces a signal directly proportional to axial load. Performance is greatly improved over other types of force transducers - high sensitivity and excellent repeatability result from a highly compliant and low-stressed elastic element. A rigid tube joins the outer ends of the elastic elements; thus the separation of the two springs produces a mechanical couple that resists the overturning torque due to side loads, with minimal disturbance to the measurement of forces along the sensitive axis. Combining the features of the load cell design with the infinite resolution, high sensitivity and frictionless operation of the LVDT allows accurate measurements of extremely low forces. These measurements are generally not possible with other types of force transducers. Connecting the force transducer to a readout gives a complete instrumentation system for the measurement of load, weight, tensile or compressive forces and other similar parameters.

COMMITTEE ON MARINE STRUCTURES

Commission on Engineering and Technical Systems

National Academy of Sciences - National Research Council

The COMMITTEE ON MARINE STRUCTURES has technical cognizance over the interagency Ship Structure Committee's research program.

Stanley G. Stiansen (Chairman), Riverhead, NY
Mark Y. Berman, Amoco Production Company, Tulsa, OK
Peter A. Gale, Webb Institute of Naval Architecture, Glen Cove, NY
Rolf D. Glasfeld, General Dynamics Corporation, Groton, CT
William H. Hartt, Florida Atlantic University, Boca Raton, FL
Paul H. Wirsching, University of Arizona, Tucson, AZ
Alexander B. Stavovy, National Research Council, Washington, DC
Michael K. Parmelee, Ship Structure Committee, Washington, DC

LOADS WORK GROUP

Paul H. Wirsching (Chairman), University of Arizona, Tucson, AZ
Subrata K. Chakrabarti, Chicago Bridge and Iron Company, Plainfield, IL
Keith D. Hjelmstad, University of Illinois, Urbana, IL
Hsien Yun Jan, Martech Incorporated, Neshanic Station, NJ
Jack Y. K. Lou, Texas A & M University, College Station, TX
Naresh Maniar, M. Rosenblatt & Son, Incorporated, New York, NY
Solomon C. S. Yim, Oregon State University, Corvallis, OR

MATERIALS WORK GROUP

William H. Hartt (Chairman), Florida Atlantic University, Boca Raton, FL
Fereshteh Ebrahimi, University of Florida, Gainesville, FL
Santiago Ibarra, Jr., Amoco Corporation, Naperville, IL
Paul A. Lagace, Massachusetts Institute of Technology, Cambridge, MA
John Landes, University of Tennessee, Knoxville, TN
Mamdouh M. Salama, Conoco Incorporated, Ponca City, OK
James M. Sawhill, Jr., Newport News Shipbuilding, Newport News, VA

SHIP STRUCTURE COMMITTEE PUBLICATIONS

- SSC-343 Global Ice Forces and Ship Response to Ice - A Second Season by P. Minnick and J. W. St. John 1990
- SSC-344 Development of an Onboard Strain Recorder by Eric Greene and William A. Wood 1987
- SSC-345 Elastic-Plastic Fracture Mechanics by T. L. Anderson 1990
- SSC-346 Fatigue Characterization of Fabricated Ship Details - Phase 2 by K. K. Park and F. V. Lawrence, Jr. 1988
- SSC-347 Strategies for Nonlinear Analysis of Marine Structures by Subrata K. Chakrabarti 1988
- SSC-348 Corrosion Experience Data Requirements by Karl A. Stambaugh and John C. Knecht 1988
- SSC-349 Development of a Generalized Onboard Response Monitoring System (Phase I) by F. W. DeBord, Jr. and B. Hennessy 1987
- SSC-350 Ship Vibration Design Guide by Edward F. Noonan 1989
- SSC-351 An Introduction to Structural Reliability Theory by Alaa E. Mansour 1990
- SSC-352 Marine Structural Steel Toughness Data Bank by J. G. Kaufman and M. Prager 1990
- SSC-353 Analysis of Wave Characteristics in Extreme Seas by William H. Buckley 1989
- SSC-354 Structural Redundancy for Discrete and Continuous Systems by P. K. Das and J. F. Garside 1990
- SSC-355 Relation of Inspection Findings to Fatigue Reliability by M. Shinozuka 1989
- SSC-356 Fatigue Performance Under Multiaxial Load by Karl A. Stambaugh, Paul R. Van Mater, Jr., and William H. Munse 1990
- SSC-357 Carbon Equivalence and Weldability of Microalloyed Steels by C. D. Lundin, T. P. S. Gill, C. Y. P. Qiao, Y. Wang, and K. K. Khan 1991
- SSC-358 Structural Behavior After Fatigue by Brian N. Leis 1987
- None Ship Structure Committee Publications - A Special Bibliography 1983