

SSC-386

SHIP MAINTENANCE PROJECT

Volume 2

Corrosion Damage Evaluation

This document has been approved
for public release and sale; its
distribution is unlimited

SHIP STRUCTURE COMMITTEE

1995

50%

SSC-386 SHIP MAINTENANCE PROJECT Volume 2

Ship Structure Committee 1995

II spine

copy for [unclear]

SHIP STRUCTURE COMMITTEE

The SHIP STRUCTURE COMMITTEE is constituted to prosecute a research program to improve the hull structures of ships and other marine structures by an extension of knowledge pertaining to design, materials, and methods of construction.

RADM J. C. Card, USCG (Chairman)
Chief, Office of Marine Safety, Security
and Environmental Protection
U. S. Coast Guard

Mr. Thomas H. Peirce
Marine Research and Development
Coordinator
Transportation Development Center
Transport Canada

Mr. Edwin B. Schimler
Associate Administrator for Ship-
building and Technology Development
Maritime Administration

Dr. Donald Liu
Senior Vice President
American Bureau of Shipping

Mr. Robert McCarthy
Director, Survivability and Structural
Integrity Group (SEA O3P)
Naval Sea Systems Command

Mr. Thomas Connors
Acting Director of Engineering (N7)
Military Sealift Command

Dr. Ross Graham
Head, Hydronautics Section
Defence Research Establishment-Atlantic

EXECUTIVE DIRECTOR

CDR Stephen E. Sharpe, USCG
U. S. Coast Guard

CONTRACTING OFFICER TECHNICAL REPRESENTATIVE

Mr. William J. Siekierka
Naval Sea Systems Command

SHIP STRUCTURE SUBCOMMITTEE

The SHIP STRUCTURE SUBCOMMITTEE acts for the Ship Structure Committee on technical matters by providing technical coordination for determining the goals and objectives of the program and by evaluating and interpreting the results in terms of structural design, construction, and operation.

MILITARY SEALIFT COMMAND

Mr. Robert E. Van Jones (Chairman)
Mr. Rickard A. Anderson
Mr. Michael W. Touma
Mr. Jeffrey E. Beach

MARITIME ADMINISTRATION

Mr. Frederick Seibold
Mr. Richard P. Voelker
Mr. Chao H. Lin
Dr. Walter M. Maclean

U. S. COAST GUARD

CAPT George Wright
Mr. Walter Lincoln
Mr. Ruben Sheinberg

AMERICAN BUREAU OF SHIPPING

Mr. Glenn Ashe
Mr. John F. Conlon
Mr. Phillip G. Rynn
Mr. William Hanzelek

NAVAL SEA SYSTEMS COMMAND

Mr. W. Thomas Packard
Mr. Charles L. Null
Mr. Edward Kadala
Mr. Allen H. Engle

TRANSPORT CANADA

Mr. John Grinstead
Mr. Ian Bayly
Mr. David L. Stocks
Mr. Peter Timonin

DEFENCE RESEARCH ESTABLISHMENT ATLANTIC

Dr. Neil Pegg
LCDR Stephen Gibson
Dr. Roger Hollingshead
Mr. John Porter

SHIP STRUCTURE SUBCOMMITTEE LIAISON MEMBERS

SOCIETY OF NAVAL ARCHITECTS AND
MARINE ENGINEERS

Dr. William Sandberg

NATIONAL ACADEMY OF SCIENCES -
MARINE BOARD

Dr. Robert Sielski

CANADA CENTRE FOR MINERALS AND
ENERGY TECHNOLOGIES

Dr. William R. Tyson

NATIONAL ACADEMY OF SCIENCES -
COMMITTEE ON MARINE STRUCTURES

Dr. John Landes

U. S. NAVAL ACADEMY

Dr. Ramswar Bhattacharyya

WELDING RESEARCH COUNCIL

Dr. Martin Prager

U. S. MERCHANT MARINE ACADEMY

Dr. C. B. Kim

AMERICAN IRON AND STEEL INSTITUTE

Mr. Alexander D. Wilson

U. S. COAST GUARD ACADEMY

LCDR Bruce R. Mustain

OFFICE OF NAVAL RESEARCH

Dr. Yapa D. S. Rajapaske

U. S. TECHNICAL ADVISORY GROUP TO THE
INTERNATIONAL STANDARDS ORGANIZATION

CAPT Charles Piersall

MASSACHUSETTS INSTITUTE OF TECHNOLOGY

CAPT Alan J. Brown

STUDENT MEMBER

Mr. Jason Miller
Massachusetts Institute of Technology

COMMITTEE ON MARINE STRUCTURES

Commission on Engineering and Technical Systems

National Academy of Sciences – National Research Council

The COMMITTEE ON MARINE STRUCTURES has technical cognizance over the interagency Ship Structure Committee's research program.

John Landes, University of Tennessee, Knoxville, TN

Howard M. Bunch, University of Michigan, Ann Arbor, MI

Bruce G. Collipp, Marine Engineering Consultant, Houston, TX

Dale G. Karr, University of Michigan, Ann Arbor, MI

Andrew Kendrick, NKF Services, Montreal, Quebec

John Niedzwecki, Texas A & M University, College Station, TX

Barbara A. Shaw, Chairman, Pennsylvania State University, University Park, PA

Robert Sielski, National Research Council, Washington, DC

Stephen E. Sharpe, Ship Structure Committee, Washington, DC

DESIGN WORK GROUP

John Niedzwecki, Chairman, Texas A&M University, College Station, TX

Bilal Ayyub, University of Maryland, College Park, MD

Ovide J. Davis, Pascagoula, MS

Maria Celia Ximenes, Chevron Shipping Co., San Francisco, CA

MATERIALS WORK GROUP

Barbara A. Shaw, Chairman, Pennsylvania State University, University Park, PA

David P. Edmonds, Edison Welding Institute, Columbus, OH

John F. McIntyre, Advanced Polymer Sciences, Avon, OH

Harold S. Reemsnyder, Bethlehem Steel Corp., Bethlehem, PA

Bruce R. Somers, Lehigh University, Bethlehem, PA

RECENT SHIP STRUCTURE COMMITTEE PUBLICATIONS

Ship Structure Committee Publications – A Special Bibliography

- SSC-384 Post-Yield Strength of Icebreaking Ship Structural Members C. DesRochers, J. Crocker, R. Kumar, D. Brennan, B. Dick, S. Lantos 1995
- SSC-383 Optimum Weld-Metal Strength for High Strength Steel Structures R. Dexter and M. Ferrell 1995
- SSC-382 Reexamination of Design Criteria for Stiffened Plate Panels by D. Ghose and N. Nappi 1995
- SSC-381 Residual Strength of Damaged Marine Structures by C. Wiernicki, D. Ghose, N. Nappi 1995
- SSC-380 Ship Structural Integrity Information System by R. Schulte-Strathaus, B. Bea 1995
- SSC-379 Improved Ship Hull Structural Details Relative to Fatigue by K. Stambaugh, F. Lawrence and S. Dimitriakis 1994
- SSC-378 The Role of Human Error in Design, Construction and Reliability of Marine Structures by R. Bea 1994
- SSC-377 Hull Structural Concepts For Improved Producibility by J. Daidola, J. Parente, and W. Robinson 1994
- SSC-376 Ice Load Impact Study on the NSF R/V Nathaniel B. Palmer by J. St. John and P. Minnick 1995
- SSC-375 Uncertainty in Strength Models for Marine Structures by O. Hughes, E. Nikolaidis, B. Ayyub, G. White, P. Hess 1994
- SSC-374 Effect of High Strength Steels on Strength Considerations of Design and Construction Details of Ships by R. Heyburn and D. Riker 1994
- SSC-373 Loads and Load Combinations by A. Mansour and A. Thayamballi 1994
- SSC-372 Maintenance of Marine Structures: A State of the Art Summary by S. Hutchinson and R. Bea 1993
- SSC-371 Establishment of a Uniform Format for Data Reporting of Structural Material Properties for Reliability Analysis by N. Pussegoda, L. Malik, and A. Dinovitzer 1993
- SSC-370 Underwater Repair Procedures for Ship Hulls (Fatigue and Ductility of Underwater Wet Welds) by K. Grubbs and C. Zanis 1993
- SSC-369 Reduction of S-N Curves for Ship Structural Details by K. Stambaugh, D. Lesson, F. Lawrence, C-Y. Hou, and G. Banas 1993
- SSC-368 Probability Based Ship Design Procedures: A Demonstration by A. Mansour, M. Lin, L. Hovem, A. Thayamballi 1993
- SSC-367 Fatigue Technology Assessment and Strategies for Fatigue Avoidance in Marine Structures by C. C. Capanoglu 1993

Member Agencies:

American Bureau of Shipping
Defence Research Establishment Atlantic
Maritime Administration
Military Sealift Command
Naval Sea Systems Command
Transport Canada
United States Coast Guard



Ship
Structure
Committee

An Interagency Advisory Committee

27 October, 1995

Address Correspondence to:

Executive Director
Ship Structure Committee
U.S. Coast Guard (G-MMS/SSC)
2100 Second Street, S.W.
Washington, D.C. 20593-0001
Ph:(202) 267-0003
Fax:(202) 267-4816

SSC-386

SR-1340

SHIP MAINTENANCE PROJECT

This report summarizes the results of a joint industry-government sponsored cooperative research project that focused on the development of engineering technology that could lead to improvements in structural maintenance for new and existing tankers. The project was a milestone in that it was conducted on behalf of 22 sponsoring and participating organizations representing government regulatory bodies, classification societies, new-build and repair yards, and ship owners and operators. In these times of fiscal austerity, future joint industry projects will continue to be essential for leveraging our industry wide research needs.

The report has been divided into four volumes; Fatigue Damage Evaluation, Corrosion Damage Evaluation, Repairs and Maintenance, and Durability Considerations. These studies developed and verified engineering guidelines for the evaluation of fatigue damage and corrosion to critical structural components of existing ships. A Repair Management System is developed to aid in the diagnosis of ship structural failures and the evaluation of repair alternatives. Finally, engineering and maintenance measures to improve the durability of critical structural details in tankers are proposed. A glossary of terms used is provided and recommendations are presented for future research.

J. C. CARD
Rear Admiral, U.S. Coast Guard
Chairman, Ship Structure Committee

1,2x

Technical Report Documentation Page

1. Report No. SSC-386		2. Government Accession No. PB96-113691		3. Recipient's Catalog No.	
4. Title and Subtitle Structural Maintenance Project Volume 2 Corrosion Damage Evaluation				5. Report Date December, 1993	
				6. Performing Organization Code SMP II-1	
7. Author(s) Bea, R.G., Mayoss, R.				8. Performing Organization Report No. SR1340	
9. Performing Agency Name and Address University of California at Berkeley Department of Naval Architecture Berkeley, CA 94720				10. Work Unit No. (TRAIS)	
				11. Contract or Grant No. 59275-SSC	
12. Sponsoring Agency Name and Address Ship Structure Committee U.S. Coast Guard (G-MMS/SSC) 2100 Second St. S.W. Washington D.C. 20593-0001				13. Type of Report and Period Covered Final Report	
				14. Sponsoring Agency Code G-M	
15. Supplementary Notes Sponsored by the Ship Structure Committee. Jointly funded by other organizations as a joint industry project. See inside the report for further details.					
16. Abstract This report is one in a series of reports conducted as part of a two year Joint Industry Research Project "Structural Maintenance for New and Existing Ships" initiated in June 1990 by the Department of Naval Architecture and Offshore Engineering of the University of California at Berkeley to both develop practical tools and procedures for the analysis of proposed ship structural repairs and to prepare guidelines for the cost effective design and construction of lower-maintenance ship structures. This project was organized into six studies. This report is based on the results of Study 2 -- Corrosion Damage Evaluations whose objective is to develop and verify engineering guidelines for the evaluation of corrosion damage to critical structural components of existing ships. This report develops a rational approach to defining corrosion limits in tankers. The objective of this project was to make advances in the area of setting allowable limits for the wastage of tanker structures based on a procedure involving rational analytical techniques as an adjunct to the traditional, experienced based approaches.					
17. Key Words Corrosion Data Bases Details			18. Distribution Statement Distribution unlimited, available from: National Technical Information Service, Springfield, VA 22161 (703) 487-4650		
19. Security Classif. (of this report) Unclassified		20. SECURITY CLASSIF. (of this page) Unclassified		21. No. of Pages 114	22. Price \$27.00



METRIC CONVERSION CARD

Approximate Conversions to Metric Measures

Symbol	When You Know	Multiply by	To Find	Symbol
LENGTH				
in	inches	2.5	centimeters	cm
ft	feet	30	centimeters	cm
yd	yards	0.9	meters	m
mi	miles	1.6	kilometers	km
AREA				
in ²	square inches	6.5	square centimeters	cm ²
ft ²	square feet	0.09	square meters	m ²
yd ²	square yards	0.8	square meters	m ²
mi ²	square miles	2.6	square kilometers	km ²
	acres	0.4	hectares	ha
MASS (weight)				
oz	ounces	28	grams	g
lb	pounds	0.45	kilograms	kg
	short tons (2000 lb)	0.9	metric ton	t
VOLUME				
tsp	teaspoons	5	milliliters	mL
Tbsp	tablespoons	15	milliliters	mL
in ³	cubic inches	16	milliliters	mL
fl oz	fluid ounces	30	milliliters	mL
c	cups	0.24	liters	L
pt	pints	0.47	liters	L
qt	quarts	0.95	liters	L
gal	gallons	3.8	liters	L
ft ³	cubic feet	0.03	cubic meters	m ³
yd ³	cubic yards	0.76	cubic meters	m ³
TEMPERATURE (exact)				
°F	degrees Fahrenheit	subtract 32, multiply by 5/9	degrees Celsius	°C

Approximate Conversions from Metric Measures

Symbol	When You Know	Multiply by	To Find	Symbol
LENGTH				
mm	millimeters	0.04	inches	in
cm	centimeters	0.4	inches	in
m	meters	3.3	feet	ft
m	meters	1.1	yards	yd
km	kilometers	0.6	miles	mi
AREA				
cm ²	square centimeters	0.16	square inches	in ²
m ²	square meters	1.2	square yards	yd ²
km ²	square kilometers	0.4	square miles	mi ²
ha	hectares (10,000 m ²)	2.5	acres	
MASS (weight)				
g	grams	0.035	ounces	oz
kg	kilograms	2.2	pounds	lb
t	metric ton (1,000 kg)	1.1	short tons	
VOLUME				
mL	milliliters	0.03	fluid ounces	fl oz
mL	milliliters	0.06	cubic inches	in ³
L	liters	2.1	pints	pt
L	liters	1.06	quarts	qt
L	liters	0.26	gallons	gal
m ³	cubic meters	35	cubic feet	ft ³
m ³	cubic meters	1.3	cubic yards	yd ³
TEMPERATURE (exact)				
°C	degrees Celsius	multiply by 9/5, add 32	degrees Fahrenheit	°F

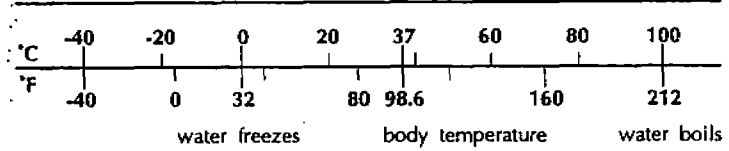
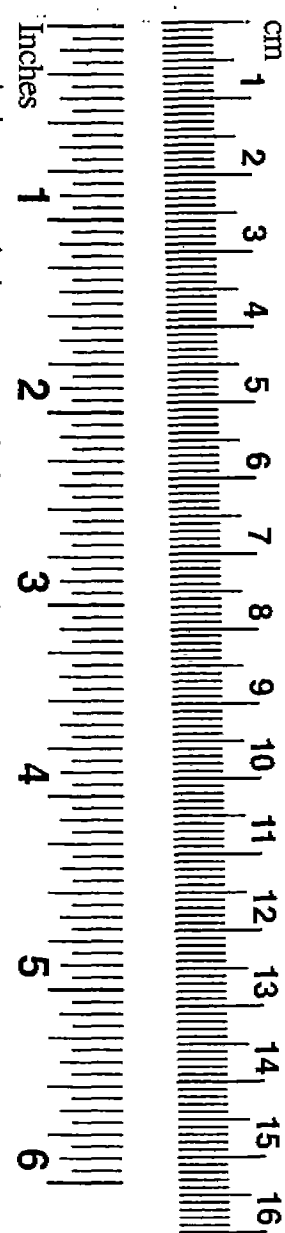

4
 (4)

Structural Maintenance Project

Volume 2 : Corrosion Damage Evaluations

CONTENTS

Cross Reference List

Corrosion Damage Evaluations :
Theory Documentation and Example
Application

Roger Mayoss

Cross Reference List for Reports under the Ship Maintenance Project

University of California, Berkeley Number	Title	SSC Report #	NTIS Accession #
	-SSC Published Reports		
SMP 1-3	Fatigue Reliability of Welded Joints in Tanker Structures	SSC-386-Vol 1	PB96-113683
SMP 1-5	Fatigue Damage Evaluation Software : Theory Documentation	SSC-386-Vol 1	PB96-113683
SMP 1-8	Fatigue Damage Evaluation Software : Verification Analysis	SSC-386-Vol 1	PB96-113683
SMP II-1	The Development of a Rational Basis for Defining Corrosion Limits in Tankers	SSC-386-Vol 2	PB96-113691
SMP 4-1	RMS - Repair Management System	SSC-386-Vol 3	PB96-113709
SMP 5-1	Durability Considerations for New and Existing Ships	SSC-386-Vol 4	PB96-113717
SMP 5-2	Advancements in Tankship Internal Structural Inspection Techniques	SSC-386-Vol 4	PB96-113717
	-The below reports are available from NTIS but were not published by the SSC		
SMP 1-6	Fatigue Damage Evaluations: User Manual	SSC-386-1-6	PB95-261608
SMP 1-7	Fatigue Damage Evaluations: Program Documentation	SSC-386-1-7	PB95-261780
SMP 1-9	Fatigue Damage Evaluations: Structural Maintenance Project Tanker Database	SSC-386-1-9	PB95-261772
SMP 1-10	Fatigue Damage Evaluations: PROSHIP- User Manual	SSC-386-1-10	PB95-261590
SMP 1-11	Fatigue Damage Evaluations: PROSHIP- Program Documentation	SSC-386-1-11	PB95-261582
SMP 2-1	Evaluation of Corrosion Damage in Crude and Product Carriers	SSC-386-2-1	PB95-261798
SMP 2-2	Corrosion Margins for Oil Tankers	SSC-386-2-2	PB95-261806
SMP 2-3	Ship Maintenance Information System	SSC-386-2-3	PB95-264016
SMP 2-4	Corrosion Damage Evaluations	SSC-386-2-4	PB95-264024
SMP 3-1	Structural Analysis and Loadings: Modeling & Analysis Strategy Development	SSC-386-3-1	PB95-264057
SMP 3-1A	Structural Analysis and Loadings: Loadings Strategy Development	SSC-386-3-1A	PB95-264065
SMP 3-2	Study of Critical Structural Details	SSC-386-3-2	PB95-264032

7,8x
G

STRUCTURAL MAINTENANCE FOR NEW AND EXISTING SHIPS

**The Development of a Rational Basis for Defining Corrosion
Limits in Tankers**

**Theory Documentation
and
Example Application**

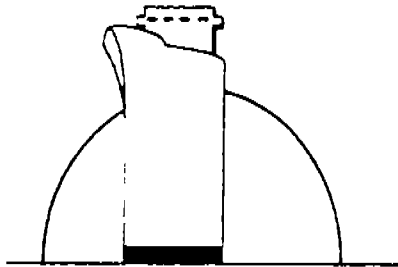

by
Roger Mayoss

and
Professor Robert G. Bea

**Report No. SMP II-1
December 1993**

Department of Naval Architecture & Offshore Engineering
University of California, Berkeley

TABLE OF CONTENTS

Table of Contents	2
1. Introduction.....	3
1.1. Overview	3
1.2. Review of Current Practice.....	3
1.3. Problem Definition	5
1.4. Solution Algorithm.....	6
1.4.1. Life Assessment	6
1.4.2. Time Variability and Corrosion Rates.....	7
1.4.3. Reliability.....	7
1.5. Ship Maintenance Information System (SMIS)	7
1.5.1. Overview	7
1.5.2. Primary Programming Considerations	8
1.5.3. Design Limitations	9
1.5.4. Context Diagram	9
2. Life Assessment.....	11
2.1. Availability	11
2.2. Support Database.....	13
2.3. Un-Availability	16
2.3.1. UPL: Planned Outages.....	17
2.3.2. UOT: Human Error and Other Causes	17
2.3.3. USF : Unavailability due to Structural Failure	17
2.4. Failure Modes	18
3. Structural Failure, Usf.....	21
3.1. Overview	21
3.2. General Procedure.....	21
3.3. Vessel Description Module.....	24
The Physical Vessel	24
3.3.1. Description of Vessel for Load Calculation	25
3.3.2. Description of Vessel for Capacity Calculation.....	29
3.3.3. Mission Profile.....	32
3.4. Demand Module.....	34
3.4.1. Overview	34
3.4.2. Environment	35
3.4.3. Environmental Effects (Load)	38
3.4.4. Stillwater Bending Moment.....	40
3.4.5. Extreme Total Vertical Bending Moment Distribution.....	41

3.4.6. Local Loads	44
3.5. Capacity Module	45
3.5.1. Overview	45
3.5.2. Element Load/End-Shortening Curves	47
3.5.3. Ultimate Capacity	53
3.6. Corrosion Module (Time Variability of Capacity)	56
3.6.1. Corrosion Data Collection and Modelling	56
3.7. Reliability Module (Probability of Failure)	58
3.8. Availability	59
4. Synthesis of the Model Application	61
4.1. Overview	61
4.2. Database Management	62
4.3. The Analytical Session	64
4.3.1. Setting up an Analytical (Life Assessment) Session	64
4.3.2. Analysis	65
5. Example Application	69
5.1. Example Vessel	69
5.2. Load Condition	73
6. Results and Conclusions	74
6.1. Results of the Example Application	74
6.2. Reliability of Sample Vessel and Corrosion Limits	77
6.3. Corrosion Limits	78
6.4. Recommendations for Future Work	79
6.4.1. Naval Architecture Topics	79
6.4.2. Computer Systems Topics	80
References	81
Appendix A: Source Code for the SMIS	
Appendix B: Section Idealization Table for the <i>Energy Concentration</i>	
Computer Disk Included in the Back Cover	

1. INTRODUCTION

1.1. OVERVIEW

In the absence of a general analytical design tool for the purpose of judging the allowable extent of corrosion wastage in oil tankers, this particular area of ship structural analysis has been given to experience-based guidelines as the only feasible treatment. In the rule books of today's classification societies, the subject of "allowable wastage" is generally absorbed into simple equations that provide some indication of a minimum strength standard for newbuild designs and renewals. While safe ships have been built and are continuing to be built under the guidelines of these rule requirements, the provisions involve a startlingly simple set of variables when one considers the complexity and diversity of the structures, the environments, and the operation philosophies involved in today's tanker trade.

This report summarizes the work done under the sponsorship of Ishikawajima-Harima Heavy Industries (IHI) and Mitsubishi Heavy Industries (MHI) to develop a rational approach to defining corrosion limits in tankers. The objective of this project was to make advances in the area of setting allowable limits for the wastage of tanker structures based on a procedure involving rational analytical techniques as an adjunct to the traditional, experienced based approaches.

1.2. REVIEW OF CURRENT PRACTICE

The prediction of the actual loss in the structural capacity of the ship structure due to corrosion can only be dealt with on a case-by-case basis. The prediction must be based on the full facts of each specific design. The

methods by which these predictions are made are, by nature, unique to each design and no attempt will be made to review them. What is reviewed here are the criteria set out by the classification societies which define minimum requirements for hull strength and how appropriate forms of corrosion control can result in allowances for scantlings below the minimum values.

A unified hull girder longitudinal strength standard has been established by the International Association of Classification Societies (IACS) which all ships, new and existing, must satisfy. This standard, which comes in the form of a simple formula for the minimum midship section modulus, embodies the vast experience that has been accumulated by the members of the classification societies and has provided adequate safety for the world's fleet of ocean-going vessels. The standard was most recently revised in 1989 and is as follows:

S7 Minimum Longitudinal Strength Standards

S7.1 The minimum midship section modulus at deck and keel for ships $90\text{ m} \leq L \leq 500\text{ m}$ and made of hull structural steel is:

$$W_{\min} = cL^2B(C_b + 0.7)k \quad (\text{cm}^3)$$

where L = rule length (m)

B = rule breadth (m)

C_b = rule block coefficient (≥ 0.60)

$c = c_n$ for new ships

$c = c_s$ for ships in service = $0.9c_n$

$$\begin{aligned} c_n &= 10.75 - \left(\frac{300 - L}{100} \right)^{3/2} \quad \text{for } 90\text{m} \leq L \leq 300\text{m} \\ &= 10.75 \quad \text{for } 300\text{m} \leq L \leq 350\text{m} \\ &= 10.75 - \left(\frac{L - 300}{100} \right)^{3/2} \quad \text{for } 350\text{m} \leq L \leq 500\text{m} \end{aligned}$$

k = material factor

= 1.0 for ordinary hull steel

< 1.0 for higher tensile steel

S7.2 Scantlings of all continuous longitudinal members of hull girder based on the section modulus requirement in S7.1 are to be maintained within 0.4L amidships.

However, in special cases, based on consideration of type of ship, hull form and loading conditions, the scantlings may be gradually reduced towards the end of the 0.4L part, bearing in mind the desire not to inhibit the vessel's loading flexibility.

S7.3 In ships where part of the longitudinal strength material in the deck or bottom area are forming boundaries of tanks for oil cargoes or ballast water and such tanks are provided with an effective corrosion protection system, certain reductions in the scantlings of these boundaries are allowed. These reductions, however, should in no case reduce the minimum hull girder section modulus for a new ship by more than 5%.

By establishing this strength standard based on the acquired experience of successful designs, a safety margin to account for the inevitable wastage of hull steel structures has been built in to the formula. The individual classification societies then go on to provide exceptions to the rule to account for unusual design concepts and the use of corrosion protection systems [1]

1.3. PROBLEM DEFINITION

It is clear that much still needs to be done to study the *problem* that corrosion presents to tanker structures even before *solutions* can be obtained. There are many sources of uncertainties that are involved in this particular aspect of the aging of a vessel, and their effects, when combined, lead to a very complicated problem. The challenge, therefore, is two-fold. First, an overall approach must be developed to coordinate the vast amount of information, data, and general theoretical concepts involved. Secondly, each component, each module of the procedure must be generated using the most efficient and accurate analytical tools and theories available given the limitations of computational resources.

There is a vast difference between the structural analysis of a particular vessel under specific conditions and the general treatment of an entire tanker fleet. Highly sophisticated proven techniques are available to accurately predict the strength of ships' structures. For example, non-linear finite element analyses exist to compute the capacity of steel structures to resist failure in a variety of failure modes, and numerical techniques are

available to accurately describe the loading environment and load effects, but these techniques are only applicable to highly detailed case-specific studies, and they come at great cost in computer time and resources.

In contrast, as mentioned previously, the foundations of the classification society corrosion wastage criteria and structural guidelines consist of very broad general methods that can only be used as guidance. While these guidelines provide a quick evaluation of a newbuild's performance or an existing ship's condition, they have no rational analytical basis, and, as quantified by Shama [2] a large undue cost can be potentially developed as a consequence of an irrationally designed structure.

What follows is a description of the attempt made during this one-year project to bridge the gap between the specific and general methods of determining corrosion wastage limits. This implies the development of a rational analytical tool that is not too expensive to use, can be used interactively (as in the early stages of design or during a routine inspection), and can be applied to the general tanker fleet. It is with this goal in mind that the project was undertaken.

1.4. SOLUTION ALGORITHM

1.4.1. Life Assessment

The task of defining corrosion limits for a complicated structural system such as an oil tanker is, in fact, just one aspect of what can be generally termed the Life Assessment paradigm. A particular vessel can age in many ways over its lifetime, and the purpose of a life assessment is to develop some global index that describes the condition of the aging vessel in terms of safety or reliability or serviceability, etc. It follows naturally that the development of a life assessment procedure will provide a convenient framework from which to begin defining these corrosion limits.

The main result of a life assessment is a description of how the defined SI (inverse measure of the probability of "failure") behaves as the vessel ages, i.e. it determines $\beta(t)$, where β is the safety index and is a function of time. Once β falls theoretically below a predetermined minimum level, β_{\min} , the

time at which this occurs can be noted, and limits can be prescribed based on how β was defined and what caused it to drop below the allowable level. It is important to note that the initial limit (β_{\min}) is determined from considerations such as economic, political, and social issues. It is then the variables that constitute the definition of β in which the engineer is interested and to which limits will be assigned.

1.4.2. Time Variability and Corrosion Rates

The time dimension in this particular application of life assessment methods is constructed by the inverse of corrosion rates multiplied by steel thicknesses. For this reason, accurate corrosion rates are an essential part of this project. In the first year of the *Structural Maintenance for New and Existing Ships Project*, Pollard focused on the determination of corrosion rates in tanker internal structures. A large amount of wastage data was gathered from a wide range of gauging reports. Statistical analyses were performed to determine corrosion rate trends based on the type of tank, the type of structural detail, and the relative location of the detail within a tank. It is this type of information that facilitates a more realistic, rational view at monitoring the decline of a vessel's structure over the course of its design lifetime.

1.4.3. Reliability

Gauging corrosion rates and their effect on ships' structures is a very uncertain proposition, therefore, it is practically useless to approach this problem from a purely deterministic point of view. Any overall safety index that can be applied to this problem is itself a random variable in the extreme, and the uncertainties grow significantly the further into the future that β is projected. Much of the uncertainty is simply inherent in this very complex problem and can not be reduced. However, a large portion of the uncertainty will come from modeling errors which reflect the limitations of the available theories.

1.5. SHIP MAINTENANCE INFORMATION SYSTEM (SMIS)

1.5.1. Overview

The ever increasing availability of computer resources and the growing refinement of analytical techniques make it possible to take a more analytical angle at the problem of predicting that point in a vessel's life when the degree of corrosion wastage renders the structure *unreliable*. Naturally, the design of a computer application is an integral part of any attempt to develop a solution to a problem of such complexity as this one. Therefore, along with the engineering considerations involved in this project, the preliminary design of an information system, the Ship Maintenance Information System, is interwoven with the theory.

The goal implicit in the development of such a system is to develop a PC application based on the developed approach which has the following qualities:

- Efficiency - Intelligent use of available resources.
- Flexibility - Built in capability for customizing the system.
- Reliability - Robust system with error checking and input validation procedures.
- Maintainability - Clear and complete system documentation both of the system design and implementation.
- Usability - Can be applied by a wide range of users.
- Accuracy - Yields reasonable and useful results.

As a supplement to the theoretical effort aimed at achieving the stated objectives, the development of a model program was proposed to illustrate the point. This report, therefore, also documents the development of the Ship Maintenance Information System (SMIS), a PC based system that was modeled after the theoretical approach developed during this one year project. The SMIS is intended to be an illustration of how such an approach could be implemented.

1.5.2. Primary Programming Considerations

The lifetime structural characteristics of a vessel fleet constitutes an extremely complex physical situation which, to model, represents a formidable and sometimes overwhelming task. The amount of data required to represent even one year of a vessel's life could fill volumes. In order to treat the many aspects of this subject, it is necessary to break this large amount of data up into small pieces that can be handled one step at a time in

manageable portions. A relational database immediately suggests itself as a means by which to achieve this organization.

FOXPRO for WINDOWS is a Microsoft relational database management system. In addition to providing the tools by which to manage large amounts of related data, FOXPRO also provides a programming language which allows the development of a sophisticated user interface and the precise control of information flow. With these powerful capabilities provided, the entire application could be developed from within the FOXPRO environment.

However, while the underlying data structure is easily constructed and the management of the data can be framed in a "user friendly" interface, there are a number of aspects of the procedure that involve a significant amount of "number crunching," or the repeated manipulation of large data sets. These procedures are not suited to the data management environment, but rather to the speed and simplicity of FORTRAN programming.

1.5.3. Design Limitations

In an attempt to design this application, it is important to realize the limitations that are implicit in the scope of this one year project. Only the first of the two main challenges stated in the overview was addressed, i.e. only the general *approach* was modeled. The scope of the rigorous technical aspects was reduced to ensure that the design itself was completed. In view of this, the following general simplifications were made:

- It was not possible to address all of the failure modes that are the result of corrosion in hull structures. The strength (capacity) analyses were focused on failure due to buckling instability of the ships' structural components. Failure due to corrosion fatigue and cracking were not dealt with directly.
- The treatment of corrosion rates was limited to general *uniform* wastage. Pitting and grooving types of corrosion were not treated
- Simplified Reliability Methods were used to limit the complexity of the System Reliability problem to a manageable level.

1.5.4. Context Diagram

Shown in Figure 1.1 is the context layer diagram for the theoretical SMIS application. A context layer data flow diagram represents the general interface between the application and the external sources and sinks of information. This particular diagram shows that a combination of vessel specific data and fleet wide data are input into the system where they are used to describe the availability (a general description of reliability) of the vessel projected over time. The system then generates a report of corrosion limits based on the results of the life assessment. The components of this system will be developed over the next three chapters.

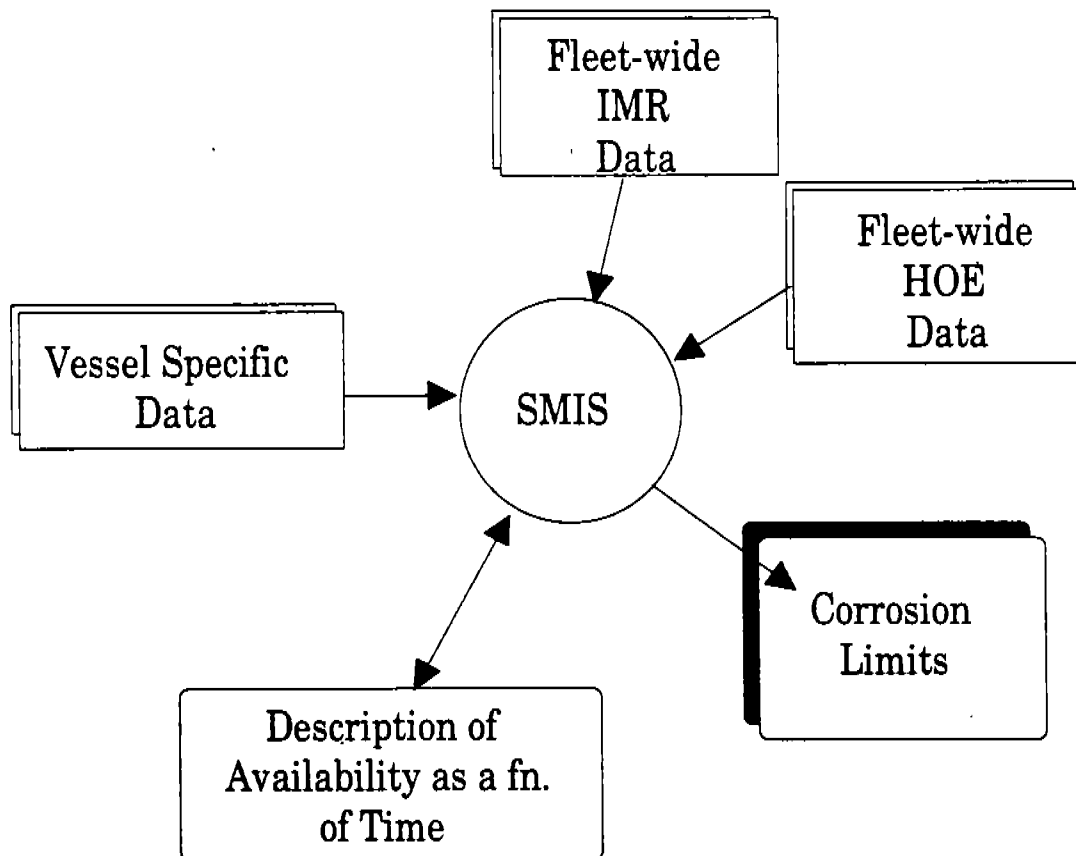

Figure 1.1: SMIS context layer diagram

2. LIFE ASSESSMENT

2.1. AVAILABILITY

A life assessment procedure provides a convenient framework from which to prescribe limiting conditions on any one of the many factors that affect the reliability of a vessel. Nippon Kaiji-Kyokai developed a model of a life assessment procedure for ships and offshore structures that could theoretically provide a comprehensive indication of the condition of a particular vessel at any one time during its operational lifetime. In this life assessment approach, the reliability is defined in terms of the **availability** of the vessel, a requirement set by the owners/operators that describes the percentage of time that the vessel *must* be in service.

During a ship's lifetime, it spends a certain amount of time being inspected or repaired. These "outages" can be attributed to three major categories of events:

1. Planned Inspection and Maintenance Routines (IMR) either required by law or set by the owners themselves (whichever is the more conservative practice).
2. The repair of structural failures that are due to a weakness in the ship's structure. These outages become more frequent as the ship ages.
3. The repair of structural failures following accidents that are caused by unforeseen extreme loading conditions and/or human and organizational error (HOE).

A numerical quantity called the *unavailability* can be defined as that fraction of time that the vessel is out of service (years-per-year) due to each of the above three categories. Respectively, these components of the total

unavailability, U , can be designated as U_{PL} , U_{SF} , U_{OT} . The availability, A_v , is expressed as:

$$A_v = 1 - U = 1 - (U_{PL} + U_{SF} + U_{OT})$$

If a design A_v is given, and provided that the components of unavailability can be accurately calculated or predicted over the life of the vessel, judgments can be made concerning the acceptable or allowable deterioration of the vessel's structural strength. The figure below schematically shows this process in terms of the above quantities.

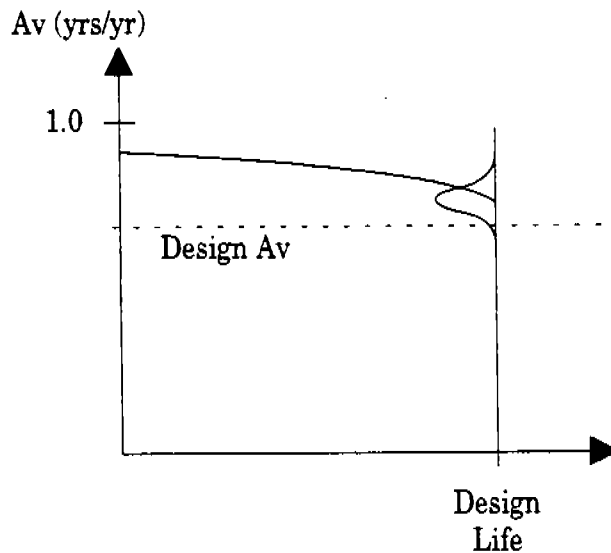

Figure 2.1 Availability as a Function of Time

In order to chart the values of unavailability over time, a combination of detailed structural analysis, experience, and a wealth of data are needed.

2.2. SUPPORT DATABASE

A database structure is needed to support the types of analyses involved in the assessment. The following three major database components serve as a starting point for the design of the required database structure:

- A preliminary survey database that would contain, among other things, information concerning the vessels particulars, its cargo, its route, its corrosion protection system, its inspection and maintenance routine, its intended service life, and its prescribed availability. (Av , U_{PL})
- A database of records and statistics of unforeseen accidents, instances of human error resulting in accidents, etc. (U_{OT})
- A database containing referential data such as gauging reports, crack inspections, the location and nature of structural failures, the time it took to repair them, etc. (U_{SF})

The nature of the analytical tool being proposed requires that a database management system be designed to maintain the data and control the flow of information. Without such a system, the tool would be difficult to employ, and then only by a small range users. Shown in fig. 2.2 is a data flow diagram (DFD) depicting the role of the database management system within the context of this project.

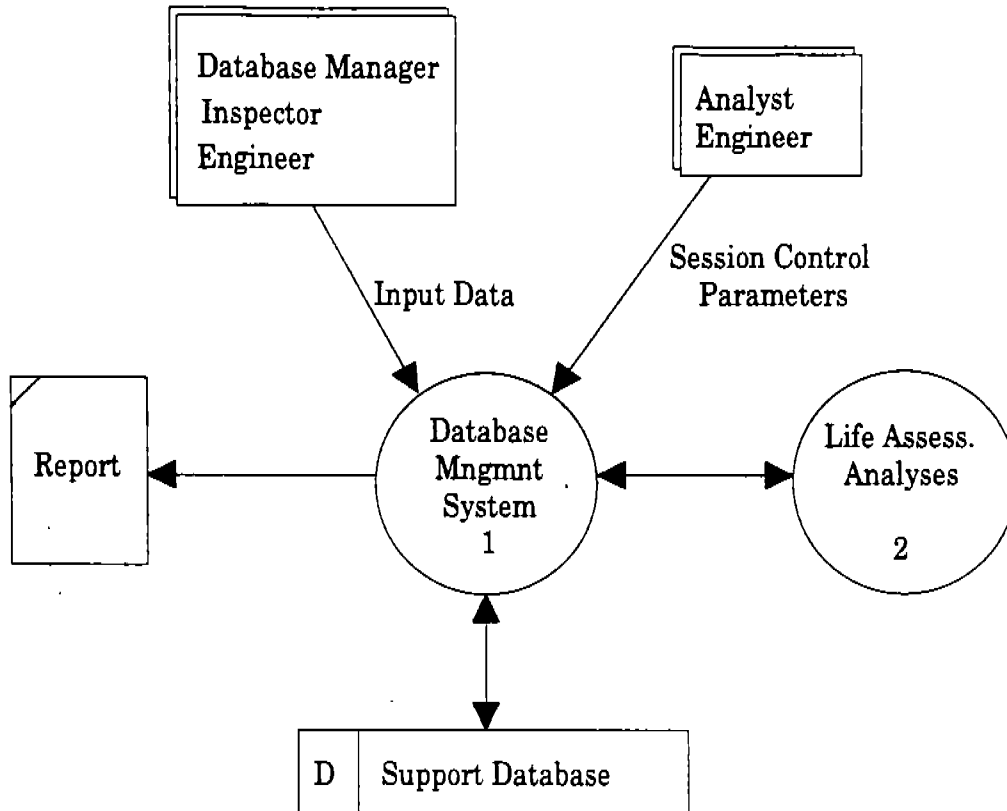

Figure 2.2: First layer DFD

As indicated in fig. 2.2, the SMIS database management system must be designed to accept input from a range of users, allow an engineer to control an analytical session, maintain and manage the data, act as a driver for the analytical routines, and produce reports to ease the interpretation of the results.

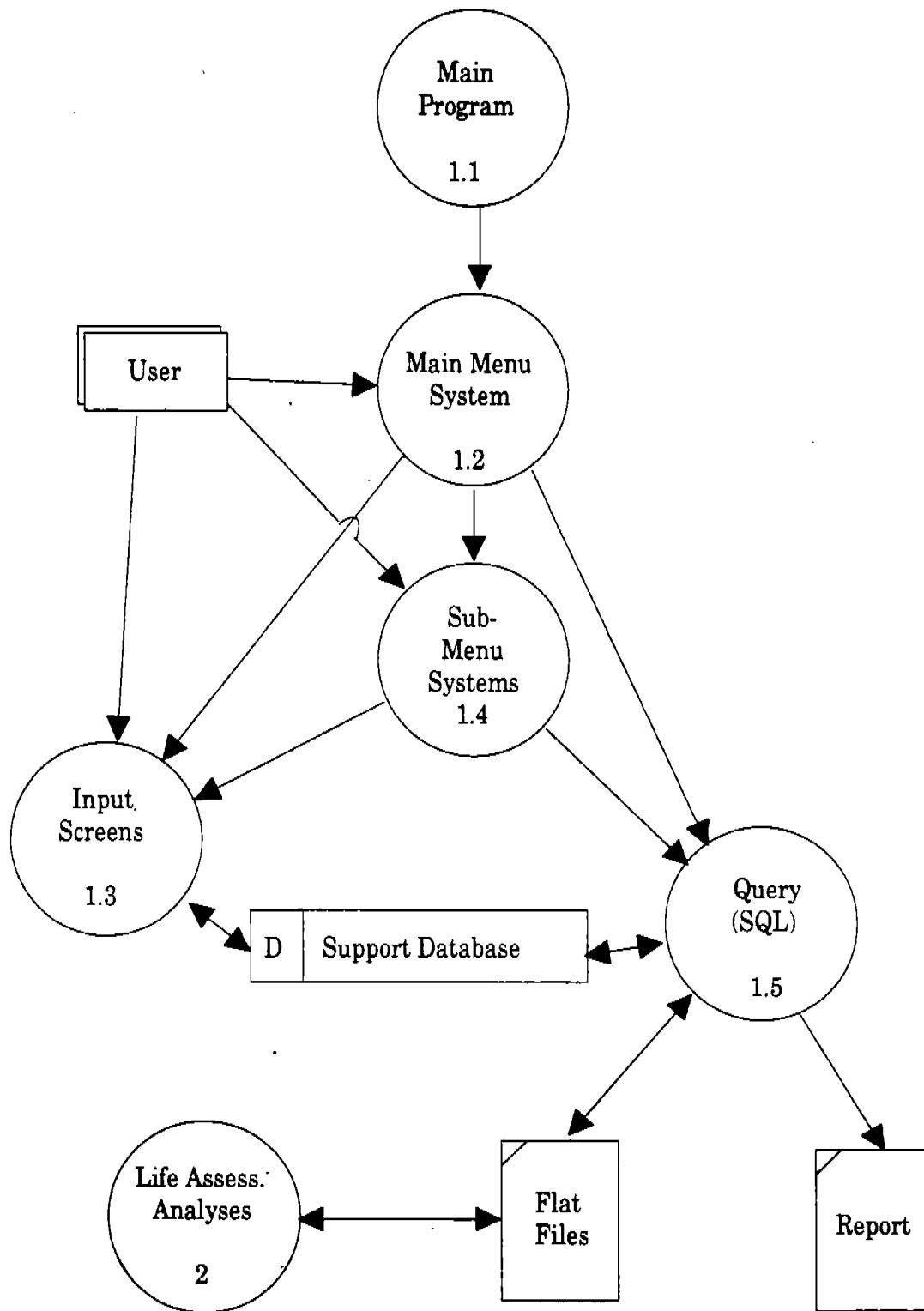

Figure 2.3: Second layer DFD - The Database Management System

Shown in fig. 2.3 is a more detailed view of the components of the database management system that are required to achieve its purpose. The exact structure of the support database, including the format of the data and how it will be used in the analysis will be discussed in the following chapters.

2.3. UN-AVAILABILITY

Figure 2.4 shows the relationship between the support database, the general analysis modules, and the three components of unavailability.

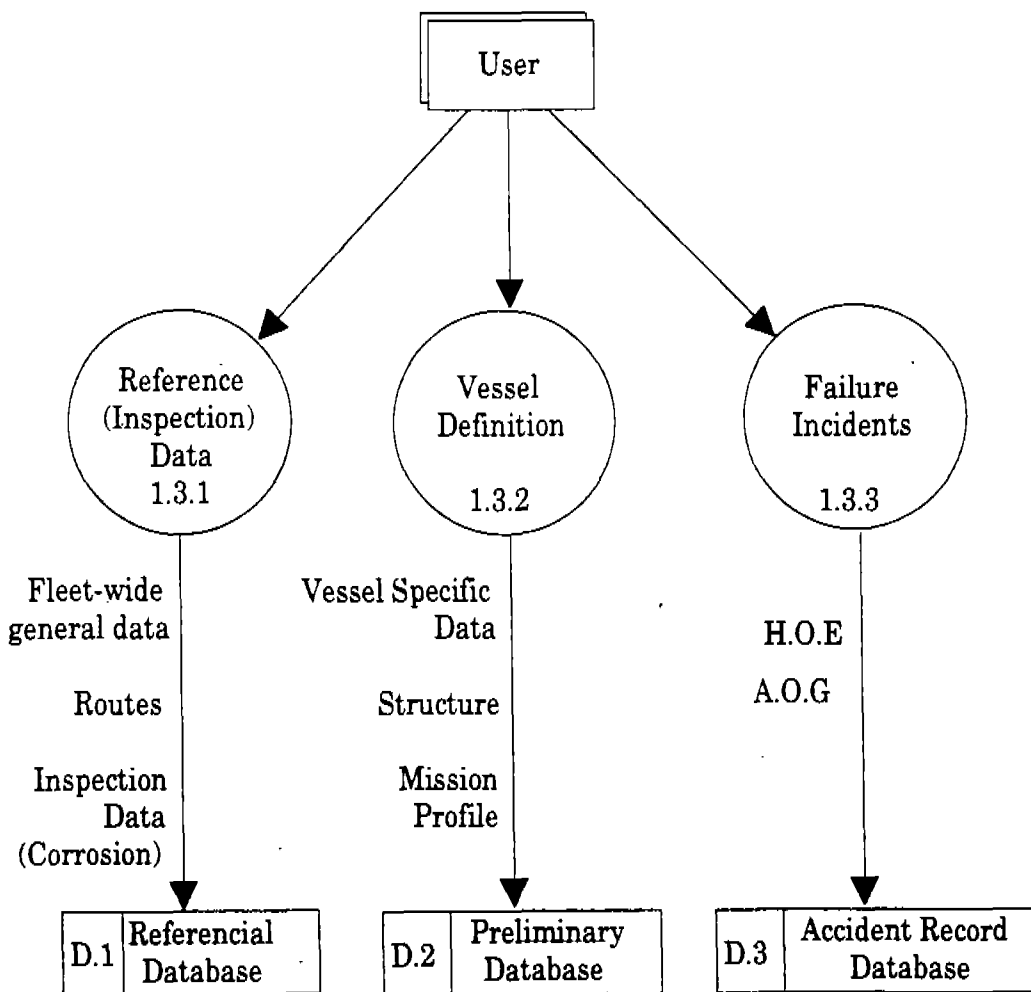

Figure 2.4: Second layer DFD - Life Assessment Analyses

25

2.3.1. **U_{PL}: Planned Outages**

The unavailability due to planned outages and the vessel's IMR can be derived from the information that is contained in the Preliminary Survey database. This quantity which may vary with time (the owner might think it necessary to decrease the amount of time between inspections as the ship gets older) must be supplied to the database.

2.3.2. **U_{OT}: Human Error and Other Causes**

The unavailability due to accidents and human error can be evaluated based on past experience. This is the reason for the database containing records and statistics of such events.

2.3.3. **U_{SF} : Unavailability due to Structural Failure**

The majority of the analytical effort undertaken in this project surrounded the calculation of the unavailability due to structural failure. This effort involves: collecting and categorizing the incidents of failure, providing a statistical interpretation of the corrosion wastage data, developing a statistical model of the prescribed loading condition, developing a best estimate of the structural capacity, and finally, through reliability methods, obtaining the annual probability of failure for each mode of failure and for each year of the service life.

U_{SF} , as defined by NK, is as follows:

$$U_{SF}(t) = \sum_{n=1}^I \frac{MTTR_n}{MTTR_n + MTBF_n(t)}$$

where there are I failure modes, and MTTR and MTBF are defined by the following:

MTTR_{*i*}: Mean time to repair failure *i*. (obtained from the structural failure incident database)

MTBF_{*i*}: Mean time between failures in the *i*th mode.

The mean time between failure for a particular mode (in years) is simply the inverse of the annual probability of failure for that mode. The calculation of the probability of failure in a particular mode is a subject of reliability analysis that is well known throughout the industry. For a given loading condition (Demand) and a predicted structural strength (Capacity) there are several levels of complexity that may be employed to obtain the probability of failure. There is a great deal of analysis, judgment, and experience that is required before meaningful results can be realized.

2.4. FAILURE MODES

For the purpose of estimating USF, it is necessary to collect structural failure incidences into general categories from which information can be drawn that will be applicable to any vessel in the fleet. In reality, no two structural failure incidences are exactly alike. However, these incidences can be classed, and it is these classes or modes of failure upon which the analytical tool will operate. According to Daidola et. al. [3] in terms of the longitudinal strength of a hull girder, there are five general categories of failure:

- Yield failure due to bending of the ship considered as a beam
- Compression instability buckling
- Brittle fracture
- Fatigue fracture
- Ultimate plastic collapse

These five general modes can be further separated into categories based primarily on the type of structural sub-elements that are affected. Only compression instability buckling and ultimate collapse are treated in this study; although, given the appropriate support data and analytical techniques, the overall procedure could be extended to treat the other three general categories of failure.

It is necessary to calculate the Mean Time Between Failure (MTBF) and the Mean Time To Repair (MTTR) for each failure mode that can be identified as being a likely to occur during the design lifetime of the vessel. The development of MTBF for a particular mode is an analytical matter that will be discussed in the next chapter. MTTR, on the other hand, must be obtained from fleet-wide data and experience in a manner similar to that for obtaining corrosion rate information. Therefore, under the heading of Referential Data, the support database must contain information in a form that will yield appropriately categorized repair information

This categorization process requires a great deal of shipyard experience and data and could potentially be carried out to a high level of detail. Unfortunately, this type of data is generally held as confidential and was not available during this study. However, some additional general categorization can be made which can serve as an illustration and a starting point for further work on this topic.

In the case of compressive instability buckling, repair information can be separated into the following five general categories:

Class I - failure leading to the replacement of longitudinal stiffeners (tripping, stiffener induced buckling, plate induced buckling)

Class II - failure leading to the replacement of internal plating between stiffeners (buckling of plating between stiffeners)

Class III - failure leading to the replacement of shell (external) plating between stiffeners (buckling of plating between stiffeners)

Class IV - failure leading to the replacement of an internal stiffened panel (overall grillage buckling)

Class V - failure leading to the replacement of an external stiffened panel (overall grillage buckling)

While these five classes cover nearly all of the types of compressive instability buckling failures, some additional information must be supplied in order to get accurate information regarding how much time a particular

vessel will be out of service because of them. For example, there is a high degree of correlation between failure modes and in the case of an entire stiffened panel being replaced, including the time it takes to repair each stiffener on the buckled panel would result in an overestimation of the repair time. These difficulties can be dealt with but only if the required information is provided.

3. STRUCTURAL FAILURE, U_{SF}

3.1. OVERVIEW

The determination of the unavailability due to year-to-year type structural failures, U_{SF} , comprises the major analytical effort of this Life Assessment routine. A large amount of data analysis as well as theoretical concepts are required to model a particular vessel's service lifetime.

As mentioned in the previous chapter, U_{SF} has been defined by NK as a function of the mean time between failure incidences and the mean time that the vessel is unavailable while the failure is being repaired.

Since specific types of failure tend to occur more often as a vessel ages, U_{SF} is a function of time and the particular failure modes that are associated with the vessel. $MTTR_n$ (Mean Time To Repair failure mode 'n') is a quantity that is obtained for each failure mode through the analysis of Inspection and Maintenance Routine (IMR) data collected and stored in the support database and will be assumed to be constant over the life of the vessel being examined. $MTBF_n$ (Mean Time Between Failure mode 'n') is cast in terms of years, and is defined as the inverse of the annual probability of failure for the n^{th} failure mode. These probabilities will increase in time due to wastage of the internal structure. Since the above summation is over all possible failure modes, there will be a marked increase in U_{SF} over the lifetime of the ship.

3.2. GENERAL PROCEDURE

The task of developing an estimate of the annual probability of failure for any given failure mode can be divided into a number of modules or

subroutines each of which constitute a major component of the calculation. These modules are listed below:

- Vessel Definition Module
- Failure Definition Module
- Capacity Module
- Demand Module
- Reliability Module
- Corrosion Module

The general procedure involves defining a section of a particular vessel's hull and the failure modes associated with it. For example, many incidences of buckling occur around the midship section where the primary bending moment is generally at its peak. These incidences might range from very localized buckling of plating between stiffeners to overall collapse of the primary structure.

Next, the loading effects are determined based on a particular vessel's geometry and loading environment. The capacity of the structure and its elements are then calculated and compared with the demands of the seaway loads. This involves the use of reliability methods that treat both individual structural elements and systems of elements. Combining knowledge of the resulting probability of failure and knowledge of the consequences (repair time) of failure for each mode results in a calculation of USF for one given time step.

Using the corrosion data contained in the referential database, corrosion rates can be calculated and applied to each element of the defined section. The designated time step defines the extent of the wastage of these elements and their capacities are then recalculated. Applying the same loads as before, the procedure for determining USF is repeated. The next time step is made, the section is corroded further, and the entire process is repeated until USF is defined over the entire Design Life of the vessel.

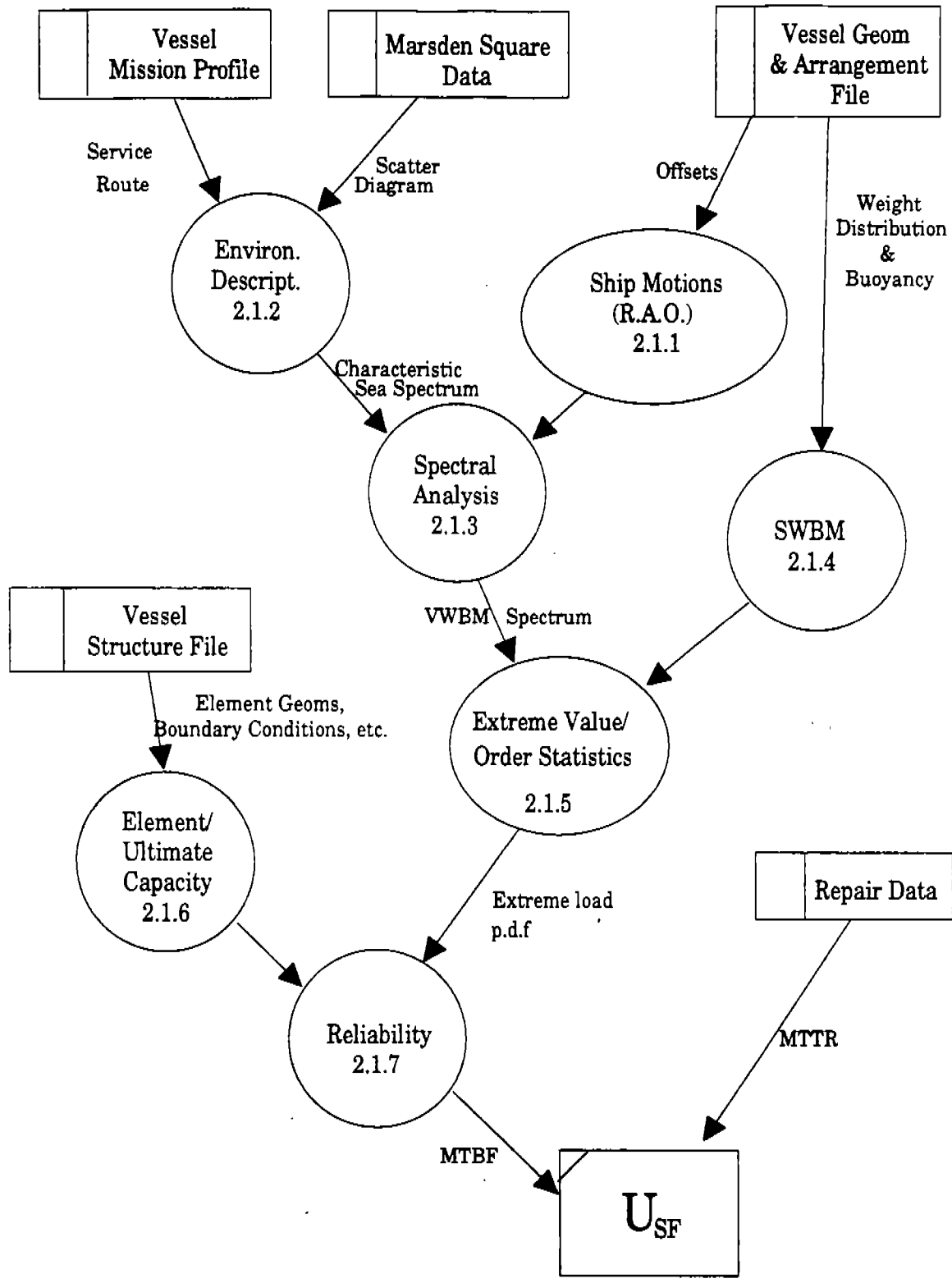

Figure 3.1: Overview of the USF Calculation

Figure 3.1 contains a data flow diagram for the calculation of U_{SF} . Components of each module in the procedure and their relationship of the support database components are depicted.

With the general procedure outlined above, what follows is a description of each module and how it fits in to the calculation of $U_{SF}(t)$.

3.3. VESSEL DESCRIPTION MODULE

Purpose: To provide all of the vessel specific information that will be needed as input to the analyses that follow in subsequent modules.

In order to complete the analyses outlined in the preceding section for a specific vessel, the preparation of a large amount of preliminary data is required. Specifically, extensive information must be provided on the physical structure of the vessel as well as its intended operational performance or *mission profile*.

The Physical Vessel

There are two main aspects involved in the physical description of a vessel. One aspect involves the description of the hull geometry and weight distribution for the purpose of calculating stillwater and vertical wave bending moments, and the other involves a description of the internal longitudinal structural components for the purpose of calculating the capacity of the hull to resist these moments.

With the obvious exception of the outside hull form, an oil tanker is generally made up of rectangular cells. It is divided internally by decks, transverse bulkheads, and longitudinal bulkheads, which constitute planar divisions parallel to the base plane, section plane, and centerline plane, respectively. Therefore, a logical point to begin the vessel description is with the designation of these major internal divisions. The configuration of the cell spaces is naturally a complicated one, and therefore, simply stating the number of each type of division will generally not lead to an accurate description of the internal spaces. In order to make this description possible, it is necessary to assume that a hierarchy exists, i.e., one type of structure represents the primary division, another type constitutes the secondary, etc.

Shown in Fig. 3.2 is one possible model for this hierarchy depicted as "one-to-many" relationships. In words it states that for every vessel there are many sections separated by transverse bulkheads, and for every section there are a number of deck levels separated by decks and inner bottoms, and, finally, for every deck level there are a number of transverse compartments separated by longitudinal bulkheads. There will naturally be configurations that can not be described by this model, however, it is simple enough to facilitate a quick and fairly realistic description of the internal arrangement of a vessel.

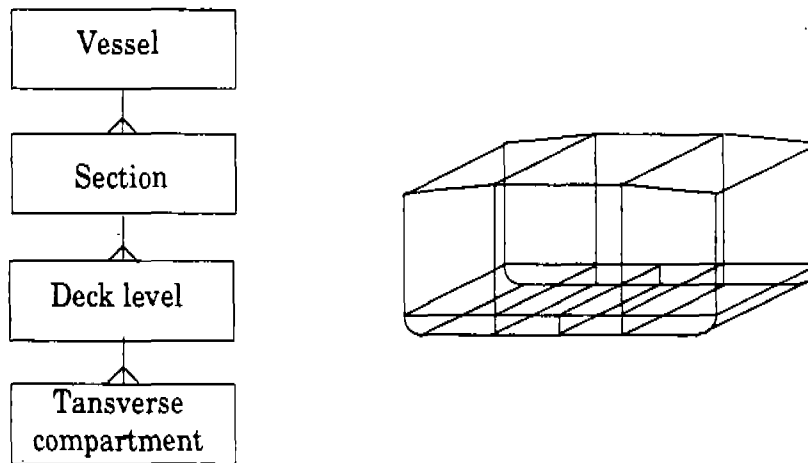

Figure 3.2: Description of the Internal Arrangement

3.3.1. Description of Vessel for Load Calculation

The loading conditions that will be experienced by a vessel during its lifetime are based on the superposition of the stillwater loads and the loads that are a result of the vessel's response to its wave environment. For the wave loads in this study, only the vertical wave bending moment will be examined as this is the primary component of the axial stresses that cause buckling in a vessel's longitudinal members. Other loads such as transverse moments and slamming will not be treated, although there is room for such analysis within the overall procedure.

As mentioned, the hull is subdivided longitudinally into stations. Typically, there are around 20 stations defined between perpendiculars and the result is a longitudinally "discretized" vessel as shown in fig. 3.3:

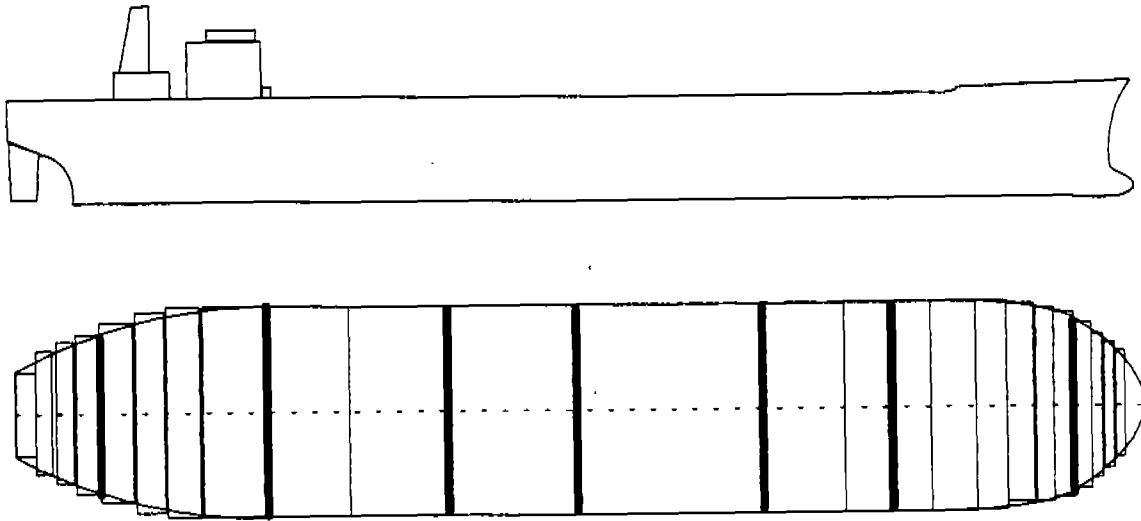

Figure 3.3: Division of a vessel into transverse sections

For the calculation of both the stillwater and vertical wave bending moment, the weight and hull form are needed at each station.

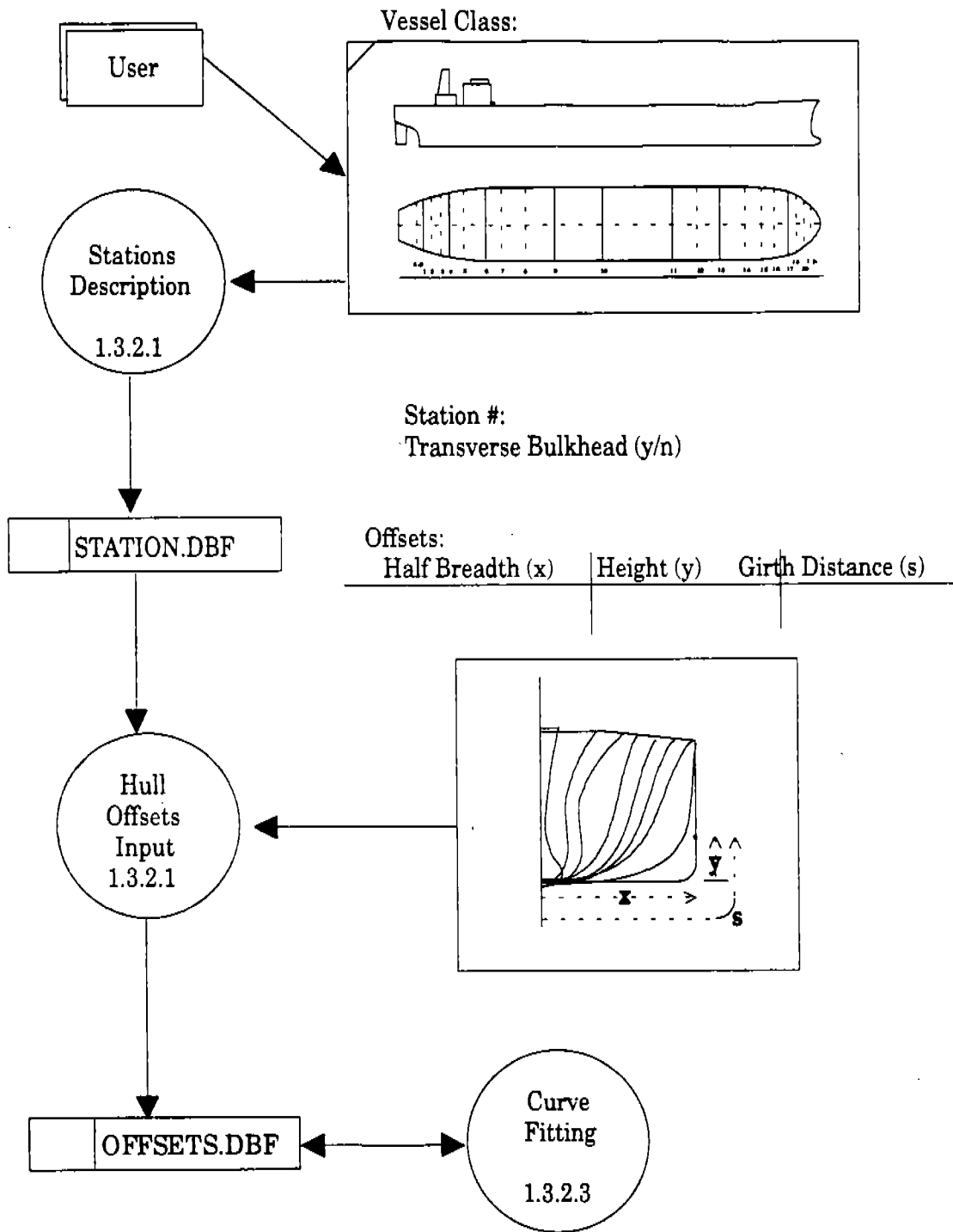

Figure 3.4: Station description for the purpose of load calculations

The computation of the stillwater loads is simply an element of the basic hydrostatic calculations that are performed in every design process. It requires a knowledge of the longitudinal weight distribution in a variety of operating conditions (most importantly: full load and ballast conditions) and also the outside form of the "wetted" hull in each operating condition for the purpose of calculating the bouyancy distribution.

3.3.2. Description of Vessel for Capacity Calculation

A mathematical idealization of a ship's structure can be acheived in many ways and to many degrees of complexity. For the purpose of this study, analyses are performed on a single transverse cross-section of the vessel hull at a time. This two-dimensional structural model is extended to three dimensions by assuming a parallel prismatic form between a specified transverse web-frame spacing.

An idealized transverse section can be subdivided into elements and groups of elements whose structural response can be estimated using established theories and structural analysis techniques. Combining system reliability methods with these element response analyses will lead to a fairly comprehensive treatment of a parallel section of the hull from individual panel buckling up to the collapse of the primary structure. What follows is a description of a method that can be implemented in such an application.

Section Idealization

Keeping in mind the assumptions and limitations of the structural analysis techniques to be used, subdiving one of a vessel's transverse sections requires some judgement in order to ensure that the the structural response (buckling) of the resulting elements are accurately described by the theories. The basic building blocks of a longitudinally framed parallel section of a vessel consist of a panel of shell plating along with an attached longitudinal stiffening structure. The term "element" used in the context of this study applies to these building blocks and examples are shown in the figures below. Fig. 3.5 & 3.6 shows a cut out panel section that could, for example, have been taken from the side shell. The shaded portion constitutes an "element" as described above and, in this particular figure, is representative of an

element that has an 'L' shaped longitudinal. Figure 3.6 shows the four cross-sectional configurations that will be considered in this study.

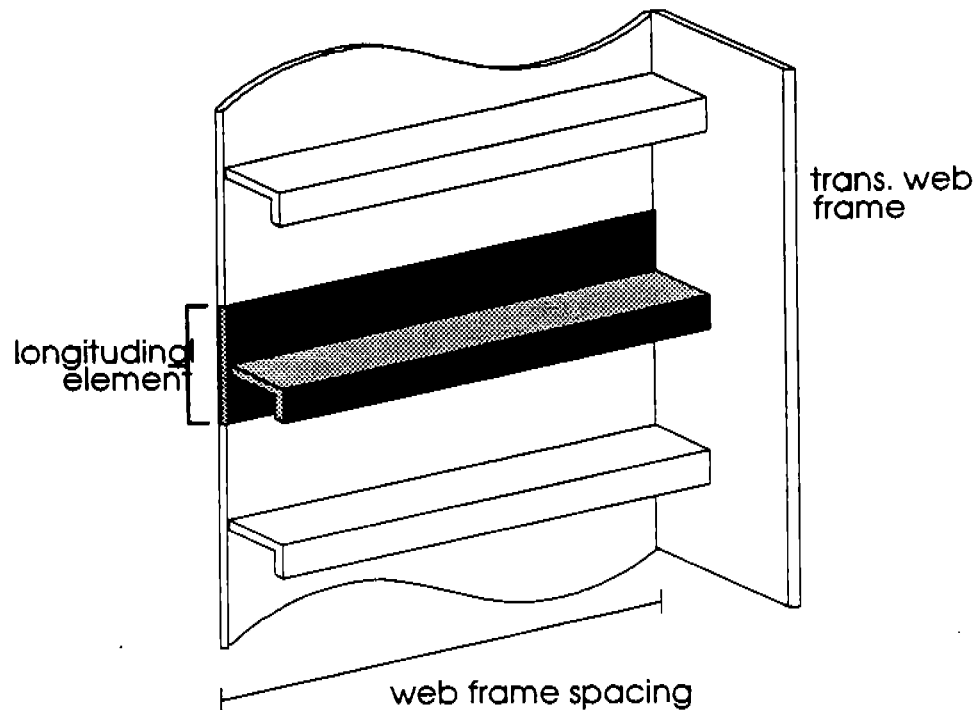

Figure 3.5: Schematic representation of an example "element"

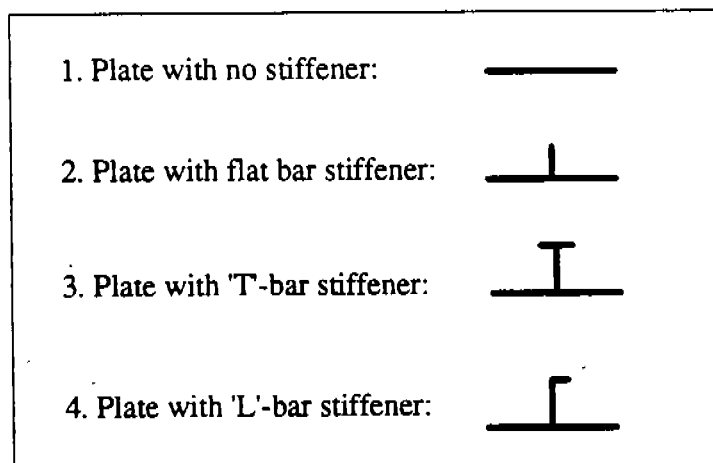

Figure 3.6: Possible configurations for element cross section.

The structural analysis routines that will be described require a fair amount of information about each element. An individual element's dimensions, location, orientation, and boundary conditions are all necessary ingredients and must be accurately described.

Dimensions: An element's dimensions consist of the cross sectional shape and plate thicknesses, and the (longitudinal) web frame spacing. Shown below is an example of the conventions used in this study:

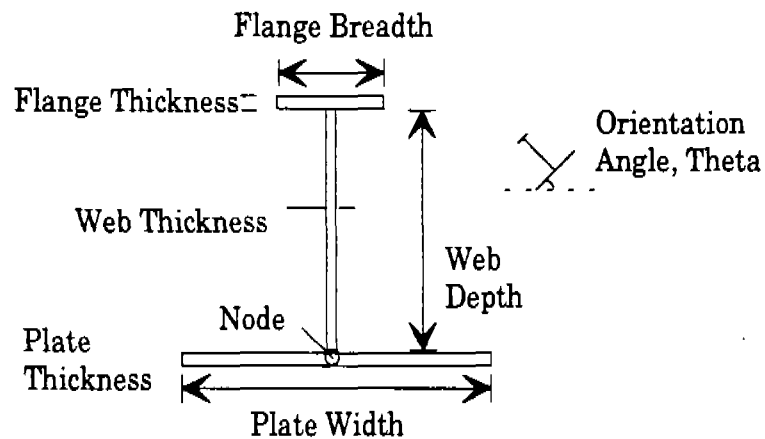

Figure 3.7: Element dimension conventions

Location: An element's location is defined as the location of the element node with respect to a coordinate system whose origin is defined as the intersection of the centerline and baseline of the section. An element's node is taken as the center of the element's plate component (see figure above).

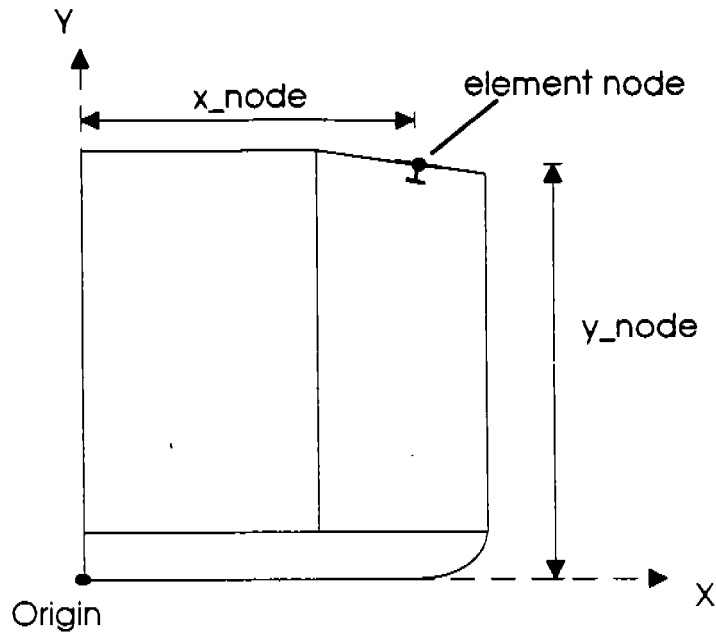

Figure 3.8: Element location.

Boundary Conditions: An element's structural response is strongly influenced by the conditions that exist at its boundaries. Through careful definition of these element boundary conditions, it is possible to model element-to-element interactions as well as the presence of lateral loads arising from hydrostatic and internal cargo pressure.

3.3.3. Mission Profile

The mission profile of a vessel outlines various information regarding the vessel's operation requirements, limitations, and expectations. For the purpose of this study, the following information is required:

- Design Lifetime (years)
- % of time in Ballast voyages
% of time in Full Load voyages
- Ballast Route (Marsden Squares and associated time factor)
Full Load Route (Marsden Squares and associated time factor)

- Operating Policy: Speed vs. Significant Wave Height for both Ballast and Full Load Conditions
- Inspection and Maintenance Routine

Shown below is a schematic example of how the *planned* unavailability can be prescribed. It reflects the possibility that planned inspection and maintenance might step up over time.

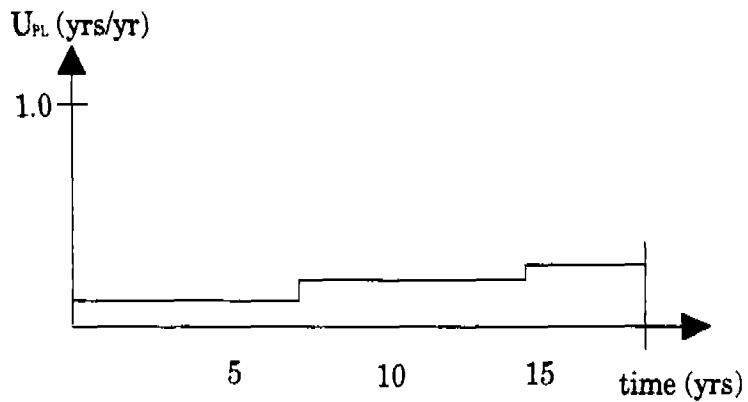

Figure 3.9: Planned unavailability

3.4. DEMAND MODULE

Purpose: To develop a probabilistic model of the extreme vertical bending moment for a specific vessel.

3.4.1. Overview

The "demand" that is imposed on a tanker vessel is made up of many different loading effects. Slamming loads, stillwater bending moments, wave loads, and inertial forces all contribute to the typical global loading conditions experienced by a vessel. In view of longitudinal strength, which is the focus of this study, only vertical bending moment will be considered since it constitutes nearly all of the demand that is placed on the longitudinal structural components.

The two principal components of this vertical bending moment are the StillWater Bending Moment (SWBM) and the Vertical Wave Bending Moment (VWBM). In deterministic terms, the Total Vertical Bending Moment (TVBM) can be expressed as:

$$TVBM = SWBM \pm VWMB$$

The Convention used here is that a negative value indicates a "sagging" moment, while a positive value indicates a "hogging" moment. In addition, a particular vessel is assumed to experience the VWBM symmetrically in the hogging and sagging mode (hence, the \pm in the equation).

In reality, there is a great deal of uncertainty associated with the above equation. Among the many factors contributing to this uncertainty, those associated with the inherent randomness of the ocean environment are dominant along with the modeling errors that are introduced as a result of the assumption that a ship responds linearly to its environment. In any case, the only rational approach to modelling the total vertical bending moment is to represent all of the factors contributing to TVBM in a probabilistic sense rather than an exact mathematic (deterministic) sense.

More specifically, both SWBM and VWBM are random variables and therefore, so is TVBM. The purpose of this module therefore is to develop an

expression for the probability distribution of TVBM for a specific vessel, given its route and response characteristics. This probabilistic representation of TVBM (demand) will then be compared to a similar representation of the Capacity of the structure to determine the failure probability.

Due to conservative design philosophies, instability of tanker structures in the buckling mode is generally brought about only by extreme environmental (wave) conditions. While the stillwater loads can be controlled and minimized to a certain extent, the extreme sea conditions make the vertical wave bending moment the dominant load effect and therefore drives the analysis of the longitudinal structure. Much work has been done to develop probabilistic models of extreme sea conditions and their effect on a vessel, and the approach taken in this study is based on that developed by Mansour [4]

3.4.2. Environment

The first step in this process involves determining what sea conditions a tanker is likely to face based on available sea data. A vessel's trade route can be separated into areas over which the sea conditions, typically characterized by significant wave height, are relatively constant. There have been a number of attempts to gather comprehensive ocean data, but there has yet to be produced an adequate set of consistent, complete measurements from which directional wave energy spectra can be derived. The most comprehensive collection of measurements to date is that compiled by Hogben and Lumb during a period of seven years from 1953 to 1961. Data involving wave height and periods were collected for areas that were grouped into Marsden square zones (shown below). An example of their data is presented below for the case of the Norwegian Sea area (Marsden square #1). In effect, the table represents a scatter diagram (observed percentage frequency of occurrence) of a combination of wave height and period.

Table 1.: Scatter Diagram for Northern North Atlantic Trade Zone (Marsden Squares 1,2,6,7, & 8)

Wave Period (seconds)

Wave Ht.	2.5	6.5	8.5	10.5	12.5	14.5	16.5	18.5	20.5	21+	Total
0-1m	13.7	3.5									
1-2	11.5	15.5									
2-3	1.6	7.9									
3-4	0.3	2.2									
4-5	0.1	0.8									
5-6	0.03	0.15									
6-7	0.03	0.15									
7-8	0.008	0.07									
8-9	0.004	0.03									
9-10	0.003	0.02									
10-11		.0005									
11+		.0005									

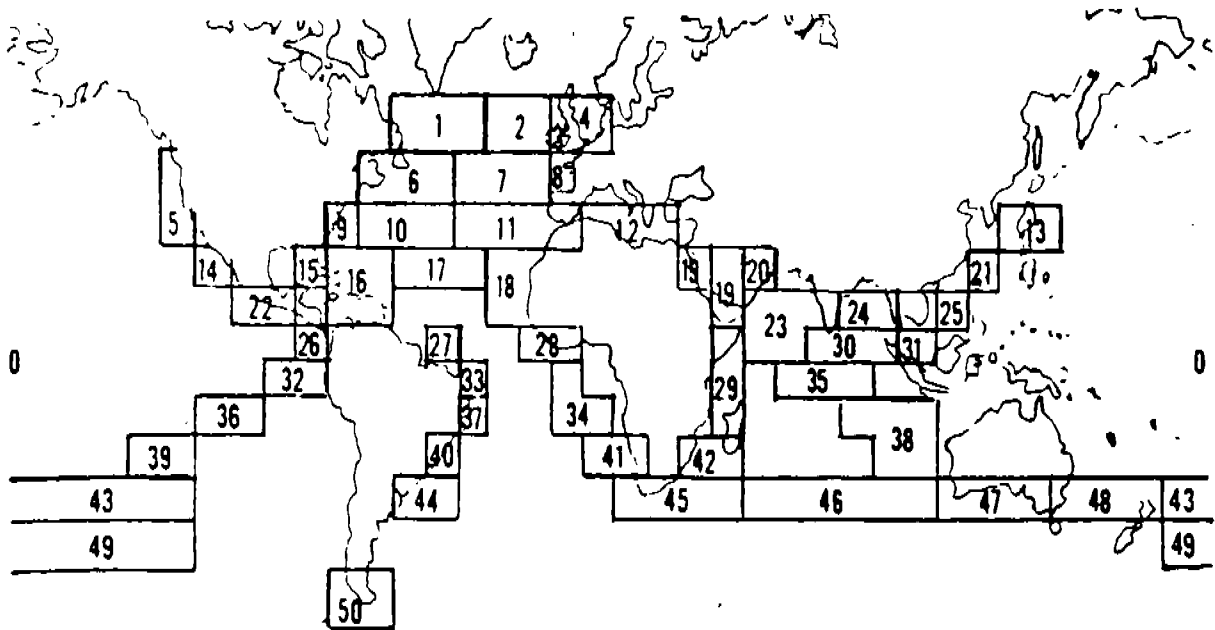

Figure 3.10: Marsden Square Zones

With a vessel's mission profile outlined in the Vessel Description Module, it is then possible to calculate the total relative frequency of occurrence for each combination of significant wave height and zero up-crossing period based on the designated Marsden Squares and the relative time spent in each one in either the ballast and full load conditions. That is:

$$p(H_s, T_z) = \sum_i p_i(H_s, T_z) \cdot f(i)$$

45

where: p_i = observed frequency of occurrence of the combination of H_s and T_z in Marsden Square, i .

$f(i)$ = the time factor (percentage of time) that the vessel spends in Square i

The summation is taken over all Marsden Squares along the vessel's route

A separate $p(H_s, T_z)$ matrix is formed for each of the two load conditions.

In order to calculate the response of a particular vessel, each sea state on the vessel's trade route must first be described in terms of a characteristic wave energy spectrum. While the set of wave records presented by Hogben and Lumb does not provide enough information to develop fully directional sea spectra for each Marsden square, there are other idealized point spectra that can be calculated from the data and that can provide valuable input to the ship response "black box" that will be discussed in the next section.

Of the various point spectra that are well known to the field, the Bretschneider Spectrum is chosen for use in this study since its two parameters (wave height and period) allow a more accurate description of a seaway than a one parameter spectrum (Pierson-Moskowitz) while the sea data available is insufficient for the development of, say, the Ochi 6-parameter spectrum.

The Bretschneider Spectrum has the form :

$$S_{\zeta}(\omega) = \frac{A}{\omega^5} \exp\left[\frac{-B}{\omega^4}\right]$$

where the parameters A and B are in fact dependent on the parameters of wave height and period. A and B have several forms depending on what characteristic values for height and period are used. For example, if Hogben and Lumb's data is presented in terms of Significant wave height (H_s) and Zero Up-crossing period (T_z), then it is convenient to express A and B in terms of H_s and T_z as follows:

$$A = 243 \frac{H_z^2}{T_z^4}; \quad \text{and} \quad B = \frac{965}{T_z^4}$$

The implication of using an idealized *point spectrum* is that the wave field in the open ocean consists of two dimensional long crested waves. This is obviously a misrepresentation of the real situation especially in storm (extreme) conditions and use of this model could potentially lead to a significant overestimation of the environment to which a vessel is subjected. The sea is generally "softened" by its directionality, and this effect may be partially accounted for by the use of a *spreading function* in conjunction with a point spectrum. At the 15th International Towing Tank Conference (ITTC 1978), it was proposed that the Bretschneider spectrum be combined with a spreading function of the form: $\frac{2}{\pi} \cos^2 \mu$ (where $-\pi/2 \leq \mu \leq \pi/2$) to model average conditions. The final form of the characteristic wave energy spectrum for a particular Marsden Square is:

$$S_{\zeta}(\omega, \mu) = \frac{2}{\pi} S_{\zeta}(\omega) \cos^2 \mu$$

where $S(\omega)$ is as defined previously.

3.4.3. Environmental Effects (Load)

With a spectral representation of any given seaway established according to the preceding section, it is possible to calculate a variety of ship response spectra for a specific vessel provided that a Transfer Function or Response Amplitude Operator (R.A.O.) can be developed for the responses of the particular vessel. For this study of course, it is the vertical wave bending moment at a transverse section that is of interest.

The calculation of the vertical wave bending moment response of a vessel at a particular section involves (first) the solution of the equations of motion for a ship in regular seas, (second) the evaluation of incremental vertical forces (excluding stillwater buoyant forces) based on these motions, and (third) the integration of these forces over the length of the vessel.

The vertical wave bending moment at a particular section is equal to the difference between the inertial force and the sum of the external forces: exciting force (E), restoring force, (R) and body motion force (D) [7].

$$VWBM(x) = I_s - (E_s + R_s + D_s)$$

Employing linear ship motion theory (along with strip theory) leads to the computation of the response amplitude operator as a function of relative wave incident angle, frequency, and ship speed. Then, under the assumption that the theory of linear superposition over the frequency domain holds true, this function can then be used as the "black box" by which the output spectrum is obtained from the input (wave energy) spectrum.

$$S_{VWBM}(\omega_e) = |RAO_{VWBM}(\omega_e, \mu_0, U_0)|^2 \cdot S_\zeta(\omega_e, \mu_0, U_0);$$

where: μ = the relative angle between the ship's forward motion and the dominant incident wave direction;

U_0 = the vessel's forward speed;

$$\omega_e = \text{the wave encounter frequency} = \left| \omega - \left(\frac{\omega^2 U_0}{g} \right) \cdot \cos \mu_0 \right|;$$

$$S_\zeta(\omega_e; \mu_0, U_0) = \frac{S_\zeta(\omega)}{|1 - (2\omega U_0/g) \cdot \cos \mu_0|}$$

In this study, information on relative heading angle is not available; therefore, it will be assumed that the "worst case" relative heading in view of vertical wave bending moment corresponds to either direct head or following seas ($\mu_0 = 0^\circ, 180^\circ$).

The calculation of extreme values of VWBM which will be discussed in section 3.5.5 requires that the value of the average (or expected) vertical wave bending moment for a specific sea condition be known. From spectral analysis, the area under $S_{VWBM}(\omega)$ or the zeroth moment of $S_{VWBM}(\omega)$, m_0 is equal to the mean square value of the response (E_{VWBM}):

$$E_{vWBM} = m_{0,vWBM} = \int_0^{\infty} S_{vWBM}(\omega) d\omega$$

And the average value, \overline{vWBM} , is related to the mean square value by the expression:

$$\overline{vWBM}(H_s, T_z) = 0.866 \sqrt{E_{vWBM}}$$

Thus, for a particular vessel, a table similar table can be developed, detailing the average vertical wave bending moment response to a given combination of H_s and T_z . This table would represent, for a specific vessel, a complete set of input data for the purpose of calculating the extreme values of vertical wave bending moments that the vessel might encounter during its lifetime.

3.4.4. Stillwater Bending Moment

It should be remembered that a tanker typically divides a significant amount of its "at sea" time between at least two different loading conditions. In this study, both full load and ballast conditions will be treated for each vessel. This distinction affects not only the stillwater moment, but also the response of the vessel to wave action due to perhaps a different draft line or more significantly, different inertia effects resulting from a redistribution of weight from one loading condition to the other.

The calculation of SWBM is a simple matter of hydrostatics and involves the difference between the Weight and Buoyancy distributions along the length of the vessel. Although the stillwater bending moment can be controlled to a certain extent and calculated fairly accurately, there still remains a significant element of uncertainty in its representation for analytical purposes. Nikolaidis and Kaplan [5] analyzed data presented by Guedes Soares and Moan (1988) and predicted that the standard deviation of stillwater bending moments for a particular tanker is about 0.21 multiplied by the rule based value. Treating the ballast and full load conditions separately would do much to reduce this estimation of uncertainty.

Due to the fact that the tanker operators have a fair amount of control and information about the stillwater bending moment, the description for SWBM for both loading conditions will be left up to the user to supply at the beginning of the life assessment rather than derived from fleetwide data as done by Nikolaidis and Kaplan. It will be assumed that SWBM follows a normal (Gaussian) probability law given by:

$$\phi_S(s) = \frac{1}{\sigma_S \sqrt{2\pi}} e^{-\frac{1}{2} \left(\frac{s-m}{\sigma_S} \right)^2}$$

where S is a random variable representing SWBM, m is equal to the mean value, $\overline{\text{SWBM}}$, and σ_S is the standard deviation. Thus, the two values, m and σ_S , need only be supplied in order to describe SWBM for a particular vessel.

3.4.5. Extreme Total Vertical Bending Moment Distribution

With a description of a vessel's environment, response to the environment in terms of vertical moment, and stillwater bending moment characteristics established as in the preceding, the extreme value distribution of the Total Vertical Bending Moment can be developed for both full load and ballast loading conditions.

The basic time increment involved in this study is a one-year period. This constitutes a "long-term" situation in view of ocean statistics. While this fact does not affect the stillwater component of the total vertical bending moment, it carries strong implications for the interpretation of the wave statics and vessel response. "Long-term" implies that the vertical wave bending response of a vessel during this time period can not be described by a stationary statistical model. However, empirical studies have shown that the amplitude of the vertical wave bending response over the long term follows (approximately) an exponential probability law with the average (expected) value of the wave bending moment as a parameter:

$$f_x(x) = \left(\frac{1}{\lambda}\right) \cdot e^{-\left(\frac{x}{\lambda}\right)} \quad x \geq 0$$

$$F_x(x) = 1 - e^{-\left(\frac{x}{\lambda}\right)} \quad x \geq 0$$

where \mathbf{X} is a random variable representing **VWBM**, and $\lambda = \overline{\text{VWBM}} =$ average value of VWBM.

Defining the random variable, \mathbf{Y}_n as the extreme value of wave bending moment, \mathbf{X} , in n records of \mathbf{X} , the use of *order statistics* permits the probability law which governs \mathbf{Y}_n to be expressed as follows [Mansour, JSR '72]:

$$\phi_{Y_n}(y) = \frac{n}{\lambda} \cdot e^{-\left(\frac{y}{\lambda}\right)} \cdot \left[1 - e^{-\left(\frac{y}{\lambda}\right)}\right]^{n-1} \quad y \geq 0$$

$$\Phi_{Y_n}(y) = \left[1 - e^{-\left(\frac{y}{\lambda}\right)}\right]^n \quad y \geq 0$$

As stated before, Hogben and Lumb's data were collected over a period of about seven years and therefore constitutes a *seven year record*. The parameter n in the above equation can be estimated for a particular vessel as the nearest integer to the value of the vessel's design life (in years) divided by seven. For example, most vessels have a design life of approximately twenty years and consequently, they span roughly three record periods of Hogben and Lumb's sea data; i.e. $n \approx 3$.

Therefore, in order to completely know the distribution of the extreme value of vertical wave bending moment, the value of the average wave bending moment over the seven year record period is the only remaining item to be calculated. Given that the average response to each sea state has been calculated along with the probability that the vessel will experience that sea state, the total average wave bending moment is then simply:

$$\lambda_j = \sum_{H_s} \sum_{T_s} \lambda_j(H_s, T_s) \cdot p_j(H_s, T_s)$$

where j corresponds to either Ballast (1) or Full Load (2) conditions

Letting T be a random variable representing the *total vertical bending moment*, the equation for TVBM can now be expressed as:

$$T_n = S \pm Y_n$$

Combining the two probability laws governing S and Y_n , leads to the following expression for T (see Mansour, 1972 for derivation):

$$\Phi_{T_n}(t) = \frac{n}{\lambda} \cdot \frac{1}{\sigma_s \sqrt{2\pi}} \int_0^{\infty} e^{-\left(\frac{t-y}{\lambda}\right) - 0.5 \left(\frac{t-y-m}{\sigma_s}\right)^2} \cdot \left[1 - e^{-\left(\frac{y}{\lambda}\right)}\right]^{n-1} dt$$

$$\Phi_{T_n}(t) = \frac{n}{\lambda} \cdot \frac{1}{\sigma_s \sqrt{2\pi}} \int_0^{\infty} e^{-\left(\frac{y}{\lambda}\right)} \cdot \left[1 - e^{-\left(\frac{y}{\lambda}\right)}\right]^{n-1} \cdot \int_{-\infty}^{\infty} e^{-0.5 \left(\frac{t-y-m}{\sigma_s}\right)^2} dt dy$$

Theoretically, this process would be repeated for each section of the vessel in both loading conditions which, for the case of a vessel with twenty designated stations, would result in forty repetitions of a process that is already computationally demanding. In order to reduce this demand, it is possible to develop the above expression for just the midship section in each of the loading conditions and then make assumptions as to how **TVBM** varies along the length of the vessel. For example, both the mean of **TVBM** and the variance could be assumed to vary along a vessels length according to a distribution factor illustrated in Fig. 3.12:

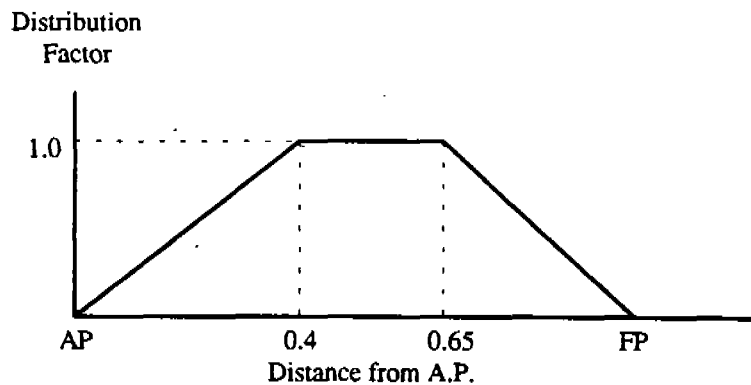

Figure 3.12: Distribution factor of TVBM along the vessel length

While this may be a bold assumption, it reduces the necessary repetitions from forty to two (one for each load case).

3.4.6. Local Loads

The calculation of local loads (i.e. axial stresses on each element as defined for a section's structure) can be achieved by employing beam theory. The axial stress σ_e , on an element at station x , and at a distance y_{na} from the instantaneous neutral axis is given by:

$$\sigma_e(x, y_e) = \frac{TVBM(x) \cdot y_{na}}{I(x)}$$

where $I(x)$ is equal to the area moment of inertia of the section about the neutral axis.

3.5. CAPACITY MODULE

Purpose: To produce, for a specified vessel, probability distribution functions of the capacity of the vessel's structure to resist the failure modes defined in the Failure Definition Module.

3.5.1. Overview

As the second aspect to the reliability problem, the Capacity module generates a probabilistic description of a vessel's structure to resist the seaway loading in both the hogging and sagging modes. The capacity of the structures defined in the Vessel Description module can be generally described in terms of their load/displacement curves. This applies to both local and ultimate failure modes.

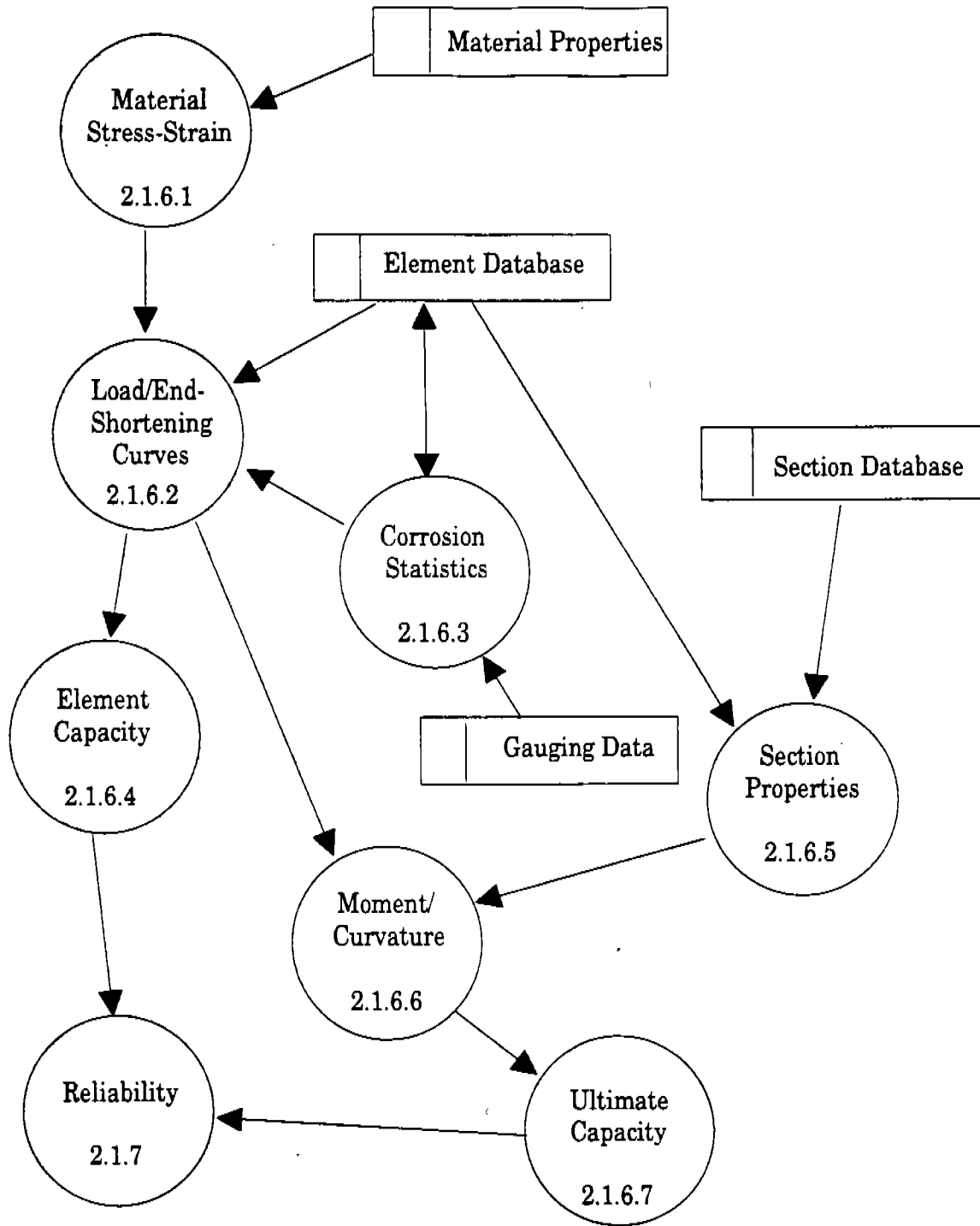

Figure 3.14: Element and Ultimate Capacity.

55

The event of an element surpassing its elastic limit due to extreme loading does not necessarily constitute failure as there is generally some residual strength left in the plastic regime. In order to maintain generality in this study, structural capacity will be defined as that level of load at which the slope of the load/displacement curve reaches zero. This, in effect, defines the ultimate limit state for each element and group of elements. While some elements may need to be replaced or repaired at lower limit states such as the elastic limit or some limiting value on displacement, this information is too detailed for the general treatment presented here.

What follows is the development of these load/displacement curves for the structures defined in the Vessel Description Module.

3.5.2. Element Load/End-Shortening Curves

Specifically, the load/displacement curve for a particular element is cast in terms of axial load vs. the shortening at the ends of the element. In view of buckling, there is a high degree of geometric non-linearity involved in the computation of this relationship. While there are many design equations and theories available to predict these curves and the buckling capacity of stiffened panels, these generally have as their basis a linear formulation with some correction factor to account for non-linearities.

The most rational approach is to deal with the non-linearities directly in a non-linear finite element formulation. With the proper load and boundary information supplied by the Vessel Description module, the structural response of each element can be determined.

Shown below are some possible finite element models that can be used to describe the types of structural arrangements and response behavior.

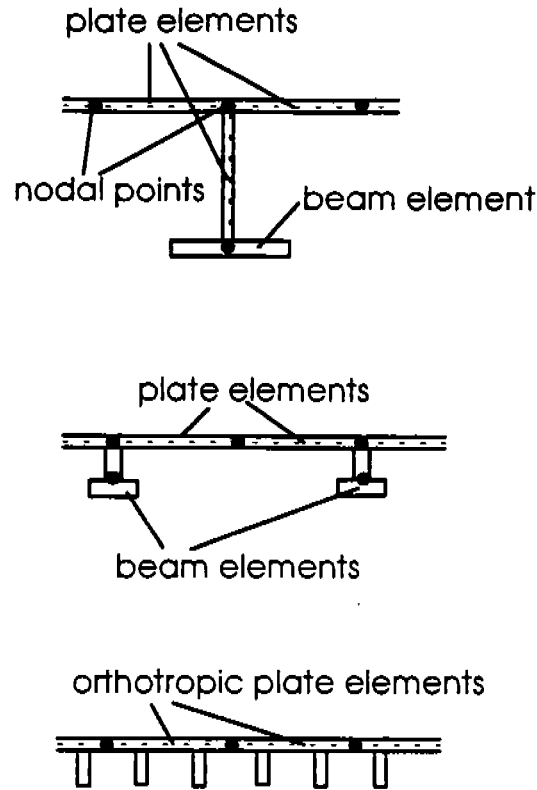

Figure 3.15: Possible Finite Element Models

There are four types of general responses that need to be modeled. They are:

- buckling of plating between stiffeners
- column buckling (stiffener or plate induced)
- stiffener tripping (or torsional buckling)
- overall panel buckling

For a given element geometry, each response mode might require a distinct finite element model in order to accurately reproduce the intended structural behavior. This could potentially result in a large computational effort, especially if the number of different types of elements for the section under consideration is large.

As an alternative, the design equations mentioned previously can be used, combining both analytical theory and empirical data to predict the critical stresses at which a stiffened panel might buckle and, further, to develop approximate load/end-shortening curves for a given element cross section. What follows is an illustrative procedure for determining these curves based on design equations.

It can be assumed that the load/end-shortening curve for a particular element can be based on the stress-strain curve of the material (steel) of which it is made. The element stress-strain curve will follow the material stress-strain curve up until a critical point at which the element becomes unstable in compression and buckles. It is necessary, therefore to first develop material stress-strain curves.

Generalized material stress-strain curves can be developed based on a relatively small number of parameters. More specifically, given (for a particular steel) the elastic section modulus, E , the yield stress, σ_{yp} , the proportional limit stress σ_p , and Poisson's ratio ν , it is possible to estimate the stress vs. strain characteristics of that steel in a complete yet approximate sense.

This is achieved by dividing the stress-strain curves into three regions signifying: (I) the linearly elastic range, (II) the nonlinear elastic range, and (III) the perfectly plastic (yield) range as shown in the figure below.

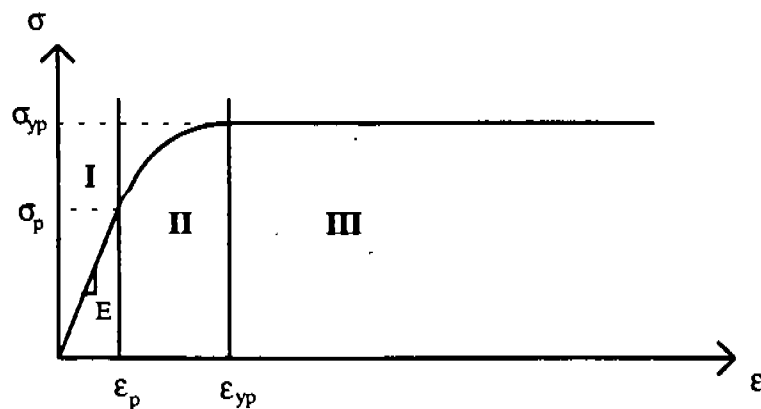

Steel Type	
E	Elastic Modulus
σ_{yp}	Yield stress
σ_p	Proportional limit
ν	Poisson's ratio

Figure 3.16: Material Properties

Region I $\epsilon \leq \epsilon_p$

The stress-strain relationship in this region is simply linear with the Elastic modulus as the constant of proportionality, i.e.

$$\sigma = E\epsilon$$

Region II $\epsilon_p < \epsilon \leq \epsilon_{yp}$

This region generally signifies a nonlinear "softening" of the material which is represented by a gradual change in the slope of the stress-strain curve. An expression for the curve in this region is as follows:

$$\sigma = \frac{\sigma_{yp}^2}{k_2} \frac{e^{(\epsilon - \epsilon_p/k_1)}}{\left[1 + \frac{\sigma_{yp}}{k_2} e^{(\epsilon - \epsilon_p/k_1)} \right]}; \quad k_1 = \frac{(\sigma_{yp} - \sigma_p)\sigma_p}{E\sigma_{yp}}, \quad k_2 = \frac{\sigma_{yp}^2 - \sigma_{yp}\sigma_p}{\sigma_p}$$

Region III $\epsilon_{yp} < \epsilon \leq \epsilon_{fp}$

Perfect plasticity is assumed in this region which is to say that the material can no longer continue to support increasing load and deforms plastically

With the material behavior defined as above, it remains to determine the critical stress at which an element becomes unstable and buckles. This critical stress can be assumed to divide the load end shortening curve into two regions, one region in which the element behaves according to the stable material behavior, and the other in which the element rapidly "sheds" its load indicated by a negative slope in the load/end-shortening curve. In general, different elements will exhibit load shedding characteristics to varying degrees, but this phenomenon is very difficult to formulate mathematically.

Buckling of the plate between stiffeners does not necessarily result in the failure of the stiffened panel. However, the buckling strength of the

stiffener/attached plating combination is strongly affected by the stiffness of the plate between stiffeners, and buckling in this region can lead to a significant reduction in the stability of the column type stiffener/plating combination. This effect can be modeled in terms of the "effective width" concept.

Shown in Fig. 3.17 is a flow chart describing the calculation of the critical buckling stress of an element. This model includes the effect of buckling of the plate between stiffeners by considering that if the critical stress of the plate between stiffeners is less than the that of the stiffener and attached plate as a column, then only an "effective" width of the plate should be considered in the computation of the column strength. The effective width is calculated using the computed critical column stress. The column stress is then recalculated using the new width of the attached plating and an iterative process is begun.

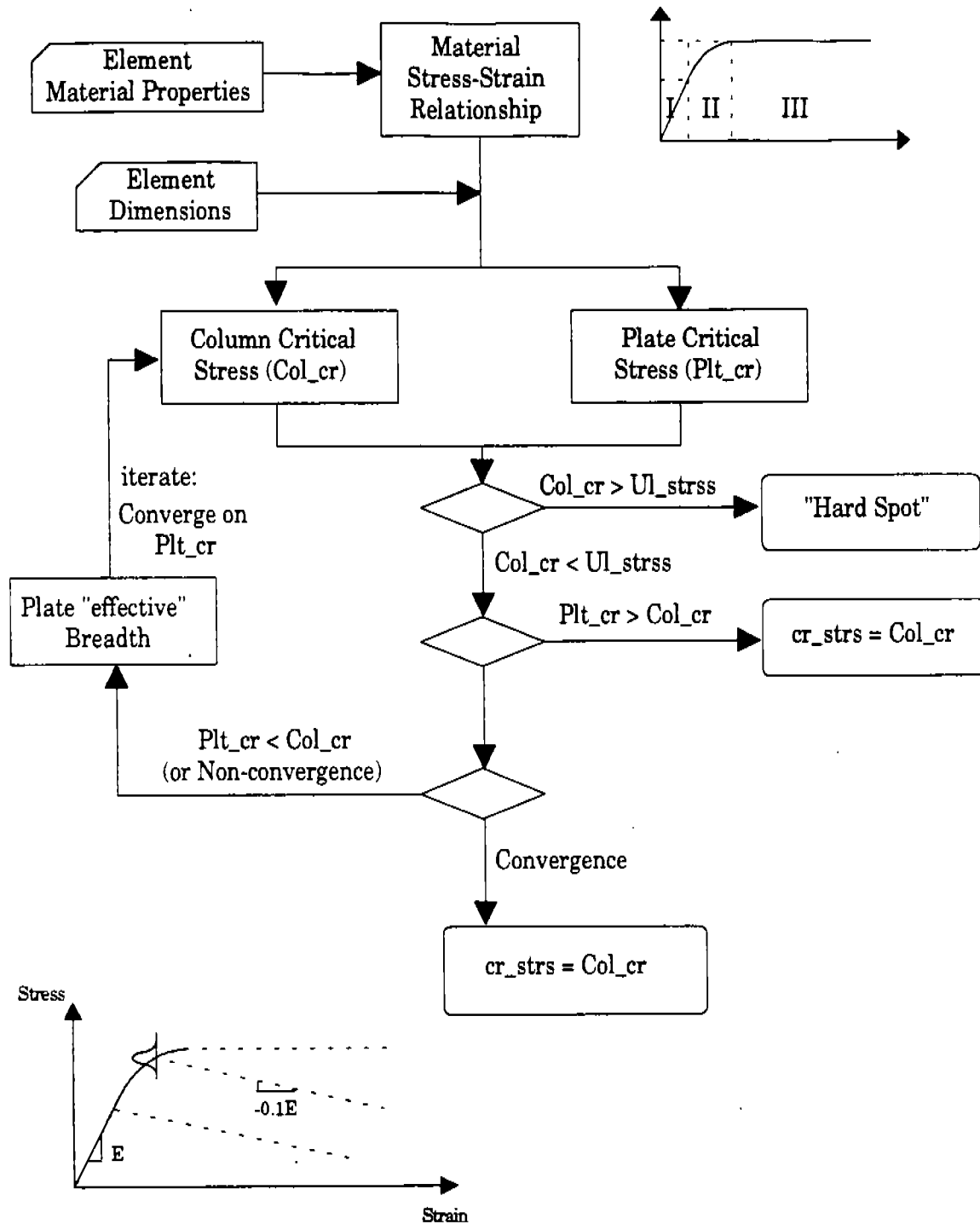

Figure 3.17: Flow Chart for Element Capacity Calculation

Another case might arise in which the critical stress of the element considered as a column is greater than the ultimate stress of the material of which it is composed. The element may then be considered as a "hard spot"

lol

meaning that the behavior of the element in compression follows that of the material.

3.5.3. Ultimate Capacity

While the finite element treatment of individual elements and specific element groups provide accurate predictions of their load/end-shortening curves, it is not feasible to apply these same methods to the entire section's structural system. The computational complexity of such a problem precludes the development of an interactive PC-based computer application.

Instead, the ultimate capacity of a given section can be determined by a method that was outlined by Smith [6]. This general procedure, outlined below, determines a Resisting Moment vs. Curvature relation for a prismatic box girder section based on the individual load/end-shortening curves of its constitutive structural elements.

Step 1: determine the properties of the section (as built or corroded). This includes calculating the second moment of area, I , and the position of the neutral axis.

Step 2: determine the elastic limit of the section, i.e. the moment and corresponding curvature at which the first element in the cross section reaches its elastic limit defined by its individual load/end-shortening curve. Theoretically, the moment curvature relation of the entire section is linear to this point.

Step 3: from the elastic limit point, apply an incremental curvature to the section the magnitude of which can be arbitrarily defined as a small percentage of the elastic limit curvature.

Step 4: with the assumption that plane sections remain plain, the strain on each element can be calculated as:

$$\epsilon_e = y_e \cdot C ; \quad y_e = \text{distance of element above neutral axis}$$
$$C = \text{section curvature}$$

62 (62)

Step 5: from each element's load/end-shortening curve, the element forces can be calculated corresponding to the strain calculated in step 4.

Step 6: Since, at this point, at least one element has passed its linear elastic point, a "softer" more flexible local structure will result in an imbalance in horizontal forces and a shift in the neutral axis is required to ensure that only a pure bending moment is acting on the section. This generally would require an iterative procedure where the neutral axis is shifted away from the plastic region, the strains and forces are recalculated, and the process is repeated until there is a zero net horizontal force. However, if the section curvature increment is small enough, one incremental shift of the neutral axis can be assumed to be accurate enough, and is given by:

$$SHIFT = \frac{\sum (A_e \cdot \sigma_e)}{C \cdot \sum (E_e \cdot A_e)}$$

Step 7: determine the bending moment that corresponds to the current state of curvature. This moment is simply calculated as:

$$M = \sum \sigma_e \cdot A_e \cdot y_e$$

Step 8: apply the next increment in section curvature.

From this point steps 4 through 8 are repeated until the complete moment/curvature relation is obtained. The flow chart in Fig. 3.18 graphically illustrates the procedure.

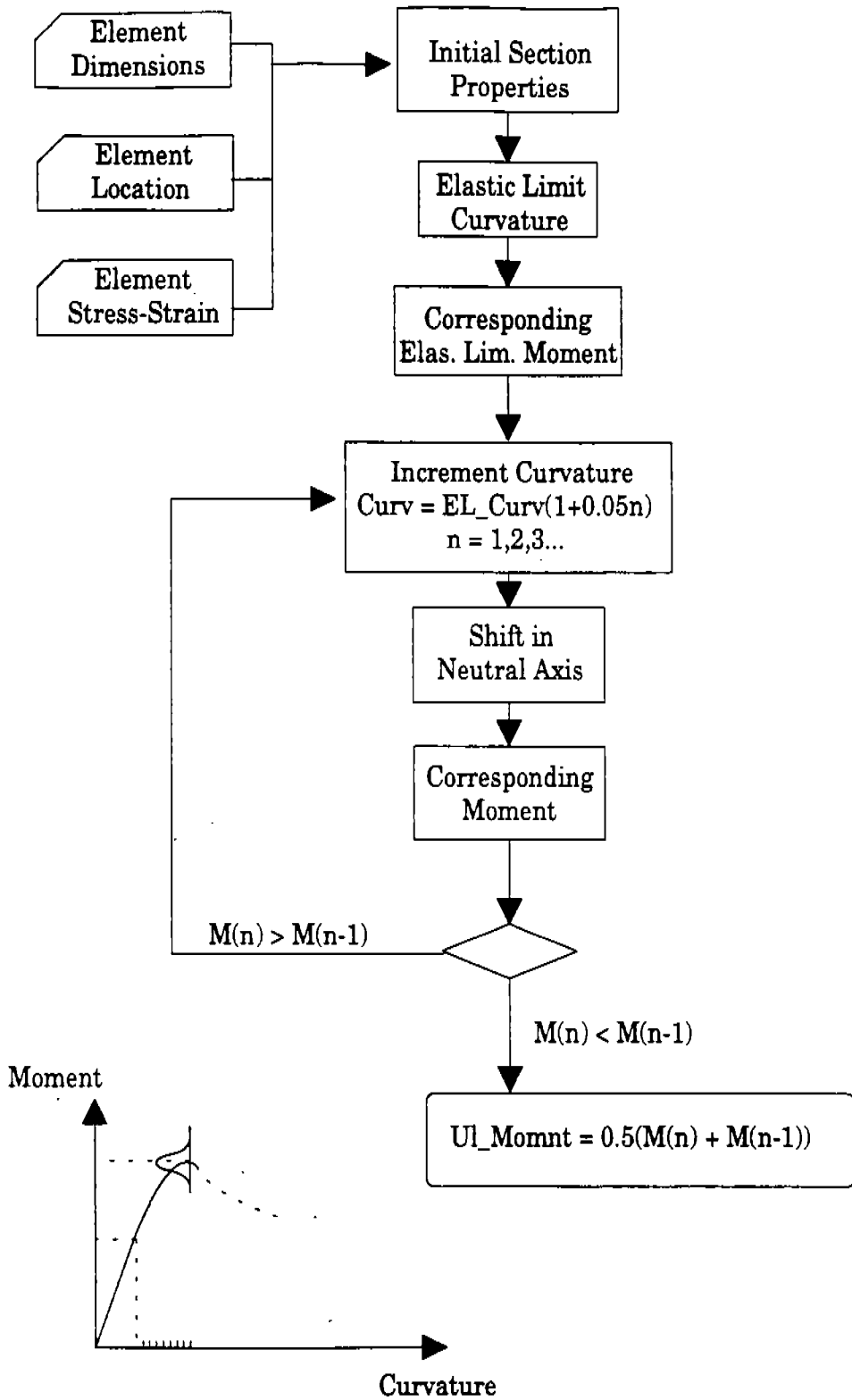

Figure 3.18 : Flow chart for Ultimate Capacity Calculation

3.6. CORROSION MODULE (TIME VARIABILITY OF CAPACITY)

Purpose: To provide a means by which to calculate corrosion rates from general wastage data drawn from the entire fleet, to assign these corrosion rates to the elements and sub-elements of the specific vessel in question, and then to control the time step procedure in the life assessment.

Although the inclusion of corrosion rates and the effect of corrosion in the life assessment procedure is a fairly straightforward matter, it is of extreme importance in that it constitutes the time variability component without which there would be no life assessment. The corrosion module consists of three parts:

- The collection of corrosion data,
- The statistical analysis of corrosion data, and
- The integration of the results into the life assessment procedure.

3.6.1. Corrosion Data Collection and Modelling

There is an abundance of gauging reports from which data can be drawn, collected during regular inspections of the entire tanker fleet over many years. The challenge involved in this part of the Corrosion Module is how to model the data in such a way that trends can be identified that will be useful to the analysis. It is not sufficient or rational to provide just one number as a representation of the corrosion rate situation for an entire vessel. There are many factors that influence the wastage of tanker structures and the values for mean rate can vary substantially throughout the body of a vessel. Pollard [8] compiled the following list of important factors effecting corrosion rates:

Ship size	Tank type	Cargo sulphur content
Delivery date	Time in cargo	Cargo water
Cargo type	Time in ballast	Wax in cargo
Double bottom	Corrosion protection	Heated cargo
Double side	system	Tank washing
Class society	Ballast type	Corrosion type
Trade route	Tank temperature	Corroded detail
Tank location	Tank humidity	Location
	Inert gas	

The corrosion rates to be used in the life assessment procedure are determined through a statistical analysis of the corrosion gauging data stored in the referencial database. During the first year of the Structural Maintenance for New and Existing Ships Project conducted at the University of California at Berkeley, these data were collected and analyzed []. Corrosion rates were categorized by a combination of tank type and detail type and also by a combination of tank type and general location within the tank. The tank types that are considered in the study fall into the following four descriptions:

- 1) Cargo only
- 2) Ballast only
- 3) Cargo/clean ballast
- 4) Cargo/dirty ballast

The second category which involves trends in corrosion wastage as they are affected by general location within the tank (upper third, middle third, lower third, etc.) provides qualitative information only, and therefore can not easily be used as input in the analysis. While location within the tank has a significant influence on the corrosion rate of the structural components, the data is not detailed enough to provide a quantification of these trends.

A further deficiency in this data model arises when one considers that the tank-type/detail-type category only gives information regarding the tank-type on one side of the plating, generally the side on which the longitudinal stiffeners are located. An area of longitudinal bulkhead plating, for example can have heated cargo on one side and cold water ballast in the adjacent wing tank, while another area of longitudinal bulkhead plating of the same cargo tank can have more heated cargo in the wing tank on the other side. This situation could result in a significantly different corrosion rate for what would be considered an identical tank-type/detail-type combination by the database.

In developing this module, efficient use can be made of the way in which the Vessel Definition Module handled the input of each structural element. A "key" identifier can be assigned to a particular sub-element plating at the time that gauging data (thicknesses) are entered into the database. For example, when a vessel undegoes inspection and a measurement is taken of

the thickness of a particular sub-element, knowledge of the element to which the plating belongs in conjunction with the section number corresponding to that element will give access to the following information from the element database:

- type of element (side shell, longitudinal bulkhead, etc.)
- the contents of the tanks to either side of the plate sub-element (cargo only, ballast only, etc.)
- the region within the tank where the element is located (ullage, middle, lower, etc)
- the original thicknesses of the sub-elements.

This information, plus the identification of the sub-element type (plate, web, flange) at the time the measurement is input, can lead to a fairly comprehensive description of the major factors that are involved in the identification of corrosion rate trends.

3.7. RELIABILITY MODULE (PROBABILITY OF FAILURE)

Purpose: To calculate the probability of failure in each failure mode defined in the Failure Definition Module based on the demand and capacity determined for the vessel in question.

Three major sources of uncertainty in the failure probability calculations come from the Capacity, Demand, and Corrosion modules. In this study there are two levels of structural failure to be examined; the element (local) failure level and the ultimate (global) failure level. With the probability density function for load approximated by the normal distribution, and with the corrosion and capacity information similarly described, the entire reliability problem reduces to the fundamental level.

For a particular failure mode i , a "safety margin", M can be defined as:

$$M_i(t) = C_i(t) - D_i$$

The probability, then, that $M < 0$ is equal to the probability that the capacity of the structure to resist failure mode i is less than the demand that is placed on the structure, which in turn is simply the probability of failure in mode i .

M constitutes a random variable, also normally distributed, whose mean value, μ , and standard deviation, σ , can be easily calculated for any time instant and any failure mode. Assuming independence between the capacity and the demand:

$$\begin{aligned}\mu_M &= \mu_C - \mu_D \\ \sigma_M &= \sqrt{\sigma_C^2 + \sigma_D^2}\end{aligned}$$

The probability of failure is therefore:

$$p_{f,t} = p[M < 0] = \Phi\left(\frac{0 - \mu_M}{\sigma_M}\right) = \Phi(-\beta)$$

where $\beta = \frac{\mu_M}{\sigma_M}$ is defined as the "safety index" and can be thought of as the number of standard deviations by which μ_M exceeds zero.

3.8. AVAILABILITY

With the various global variables defined as they have been in the preceding, there are a number of ways in which the reliability of a particular vessel can be formulated within the context of its life span. For example, the reliability can be cast in terms of the mean and standard deviation of the *time* that it takes for the calculated availability to drop below the design value, or, alternatively, the mean and standard deviation of the *availability* can be presented at the end of the vessel's design life. These two alternative formulations are presented in figure 3.20. The subtle difference between the two is that in the first formulation, the uncertainty in the time dimension is treated while the limiting availability is taken as deterministic (design A_v), whereas in the second formulation, the weight of uncertainty rests on the availability dimension while the design life determines the limiting time.

68

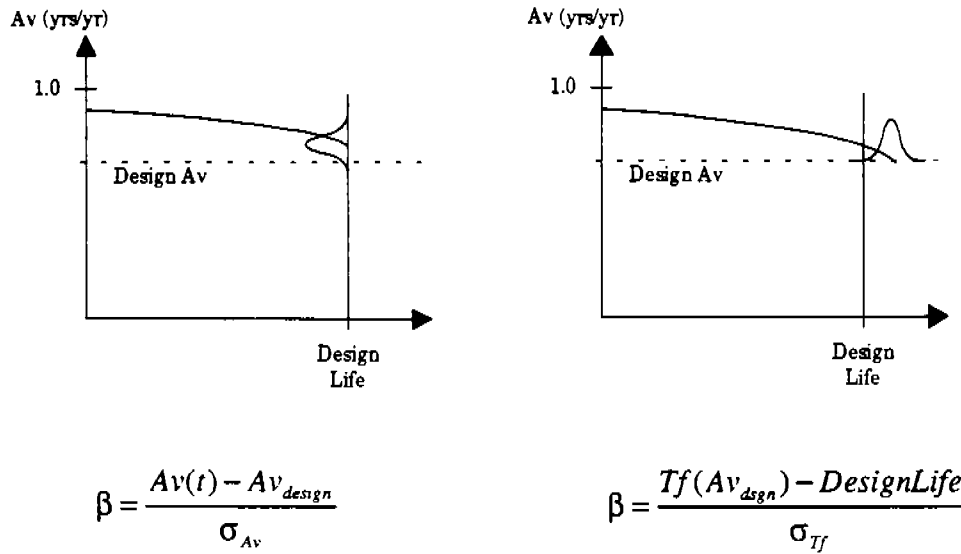

Figure 3.20: Alternative Reliability Formulations

For the purpose of defining corrosion limits, it is more important that the uncertainty in time is treated since the time dimension is directly involved in the determination of corrosion rates.

69

4. SYNTHESIS OF THE MODEL APPLICATION

4.1. OVERVIEW

Presented in this chapter is the initial development of a computer application which is modelled after the approach detailed in the preceding chapters. The following simplifications were made to facilitate the development of the model:

- 1) The load definition module was eliminated, using in its place a rule based definition of the extreme bending moment amidship.
- 2) The 'time until failure' was based solely on the ultimate capacity of a section to withstand the imposed bending moment. While this is only a component of a component of the overall availability of a vessel, it clearly and adequately represents a limiting condition, and further, the additional data and routines needed to complete the entire availability calculation was beyond the scope of this project.
- 3) The database files are accessed directly through FOXPRO, eliminating the need for the development of input screens.
- 4) Corrosion rates were 'hard-wired' or manually input to the system due to the fact that the data did not exist in the designed format. Corrosion rates were based on Pollard's findings.

Shown in Figure 4.1 is the context layer diagram for the model SMIS application. When compared with Figure 1.1 this diagram expresses the above simplifications in graphic form. By employing a rule based definition of the loads and by eliminating the need for all that is required for the calculation of the three components of Unavailability, the external inputs become simply the midship section idealization and the general parameters

used in the calculation of the extreme midship bending moment. The system then bases its definition of wastage limits on the prediction of the time that it takes for the wastage of the scantlings to decrease the ultimate capacity of the section to the point at which it no longer can satisfactorily withstand the rule based load.

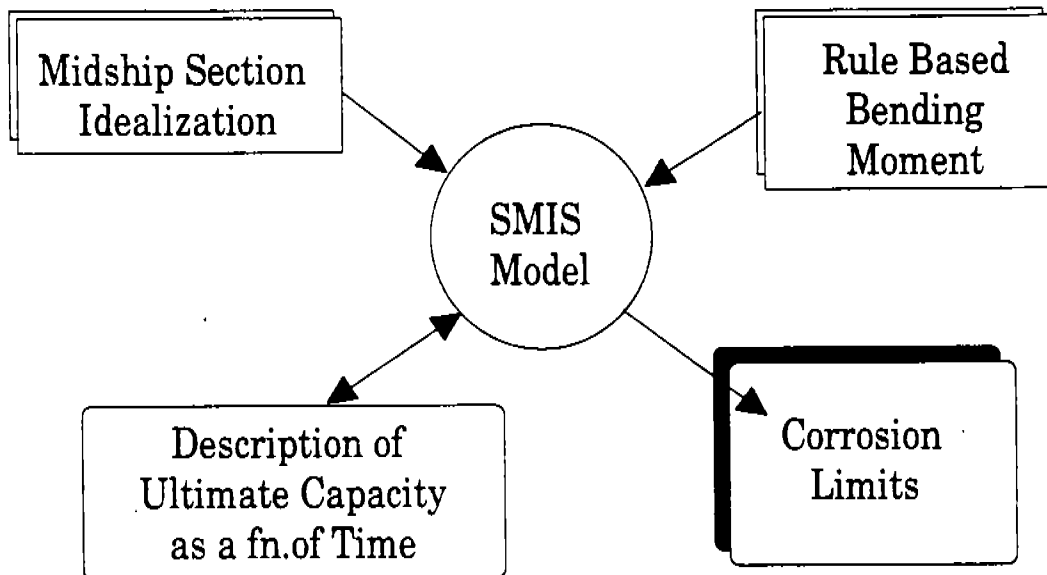

Figure 4.1: Context layer diagram for the model SMIS application

4.2. DATABASE MANAGEMENT

Without the need to support the entire unavailability calculation, the structuring and management of the database becomes considerably simpler. Direct input of data to the database files further reduces the complexity of the database management issue by eliminating the need for input screens. The principal components of the database are simply the CLASS and SECTION idealization databases. Shown in Figure 4.2 is the next layer DFD followed by the structure of the developed database (Fig. 4.3).

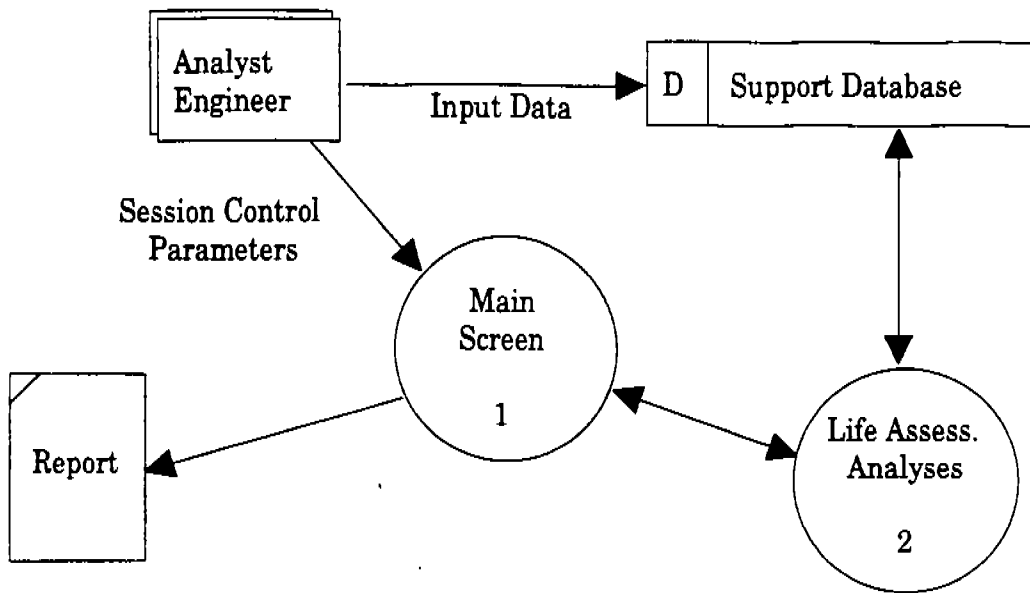

Fig 4.2: Second Layer DFD

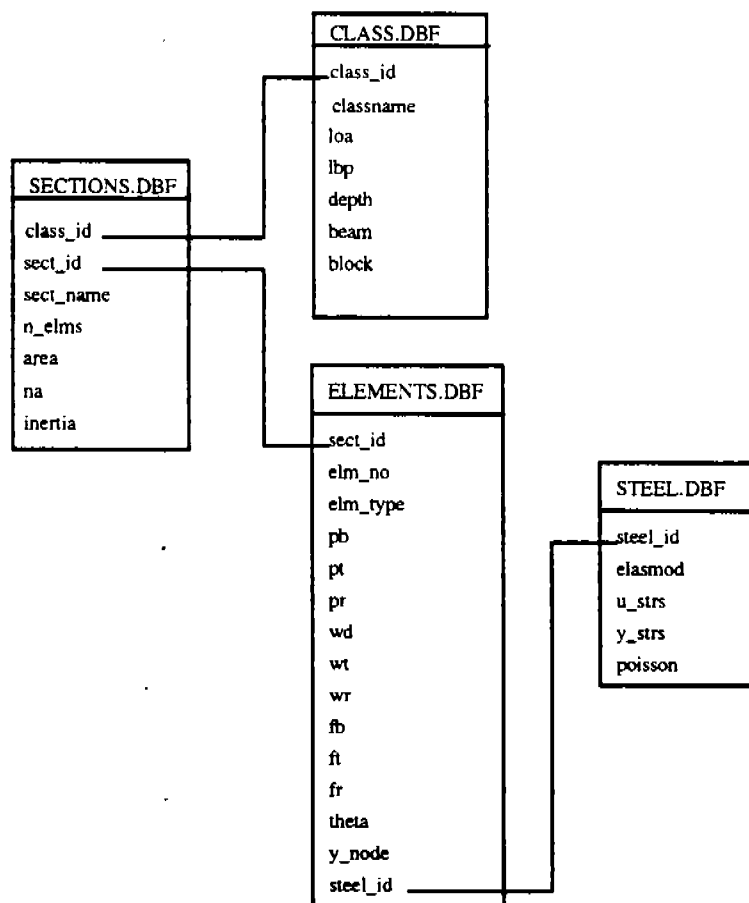

Fig 4.3: Structure of the support database for model SMIS application

72

The definition of a vessel is simply a matter of filling the data structure defined above.

4.3. THE ANALYTICAL SESSION

4.3.1. Setting up an Analytical (Life Assessment) Session

Setting up an analytical session involves little more than identifying which section of which vessel is to be considered and any biases that are applied to customize the loading condition. In addition, the time increment in years needs to be designated along with a minimum value for the safety index, β upon which the "life assessment" is based. A single main screen was developed to accept the input of these session parameters, do some elementary calculations and prompt the user to begin the analysis once the session parameters have been defined. Shown in Fig. 4.4 is this Main Screen as it appears on the monitor.

SECTION IDENTIFICATION		SESSION PARAMETERS	
Vessel Class:	216 DWT VLCC	Minimum Beta level:	0.000
Section:	Midship	Time Step (in years):	

Design LOADS:

	<input type="checkbox"/> Hog		<input type="checkbox"/> Sag	
	SWBM	VWBM	SWBM	VWBM
Mean:	5950823.0	7801106.0	246318256.0	8424342.0
Bias:	0.0	0.0	0.0	0.0
Coef. of Var.:	0.0	0.0	0.0	0.0

Figure 4.4: SMIS Main Screen

Values for the stillwater and vertical wave bending moments in both the hogging and sagging condition are automatically computed once a particular vessel class is chosen from the popup. At the same time, the "sections" popup is filled with section names for the chosen vessel and the input fields for biases and coefficients of variation are enabled and default values are displayed (1.0 for biases, and 0.0 for COV's). A field also exists for a user input "session id code" which is stored in the support database and can be used to distinguish the results of a particular analytical session for later study.

Once all of this information has been input, including the time step (typical values should be around five to seven years for this increment) and minimum β level, a button labeled "Begin" starts the analysis.

4.3.2. Analysis

The main analysis routines lie beneath the setup screen and automatically control the flow of the analysis, the links to the support database, and the generation of results. The program calculates the safety index at a particular time step based on the computation of the designated section's ultimate capacity in both hogging and sagging modes and the combination of the defined stillwater and vertical wave bending moments. If the calculated safety index is greater than the defined minimum, then the "age" of the vessel is increased by one time increment, the section's scantlings are reduced according to the appropriate corrosion rates, and the process is repeated until the safety index drops below the set minimum. In addition to calculating the safety index at each time step, the program builds moment curvature diagrams according to the procedure outlined in chapter three.

The following is a list of the principle modules that comprise the analysis routine and a brief description of each.

Module: MAIN

Purpose: This is the main module that performs the remaining preliminary computations regarding loads, coordinates the subroutines, and generally controls the flow.

Input: Session control parameters from main screen

Output: Global information regarding the section at each time step which is stored in the LIFE.DBF database (i.e. safety index, hog capacity, sag capacity, initial neutral axis, etc)

Called by: Main Screen

Calls: CORRODER, CAPACITY

Module: CORRODER

Purpose: This module develops the important "elms" array which contains the element specific information such as dimensions and material properties and includes the correct plate thicknesses according to current age of the vessel and the appropriate corrosion rates.

Input: "Temp" array which is downloaded from the ELEMENTS.DBF database and contains the element-by element description of the chosen section.

Output: "Elms" array which is similar to the Temp array but has updated the element dimensions to reflect wastage of an aged vessel.

Called by: MAIN

Calls: none

Module: CAPACITY

Purpose: This module follows the procedure for calculating ultimate capacity of a section based on the load/end-shortening curves of its constituent elements. Program is executed for a particular time step.

Input: "Elms" array described above

Output: *caphog* and *capsag* (ultimate capacity in hogging and sagging conditions) both of which are returned to the MAIN. Additionally, the moment curvature relationship is uploaded to MOMCURV.DBF.

Called by: MAIN

Calls: ELMPROPS, STRSSTRN

Module: ELMPROPS

Purpose: This module calculates three element properties which are added to the elms array.

Input: The information contained in one record (row) from the elms array

Output: *cr_strs* (critical buckling stress), *area* (cross sectional area), and *inertia* (moment of inertia about the centroid) particular to an element, and stored in columns 14,15, and 16 of the elms array

Called by: CAPACITY

Calls: none

Module: STRSSTRN

Purpose: This module returns the stress corresponding to an input strain level for a particular element based on its material properties and critical buckling stress.

Input: *cr_strs, elasm, u_strs, y_strs, poisson, strain*

Output: *stress*

Called by: CAPACITY

Shown in Fig. 4.5 is a schematic view of the modules involved in the initial application.

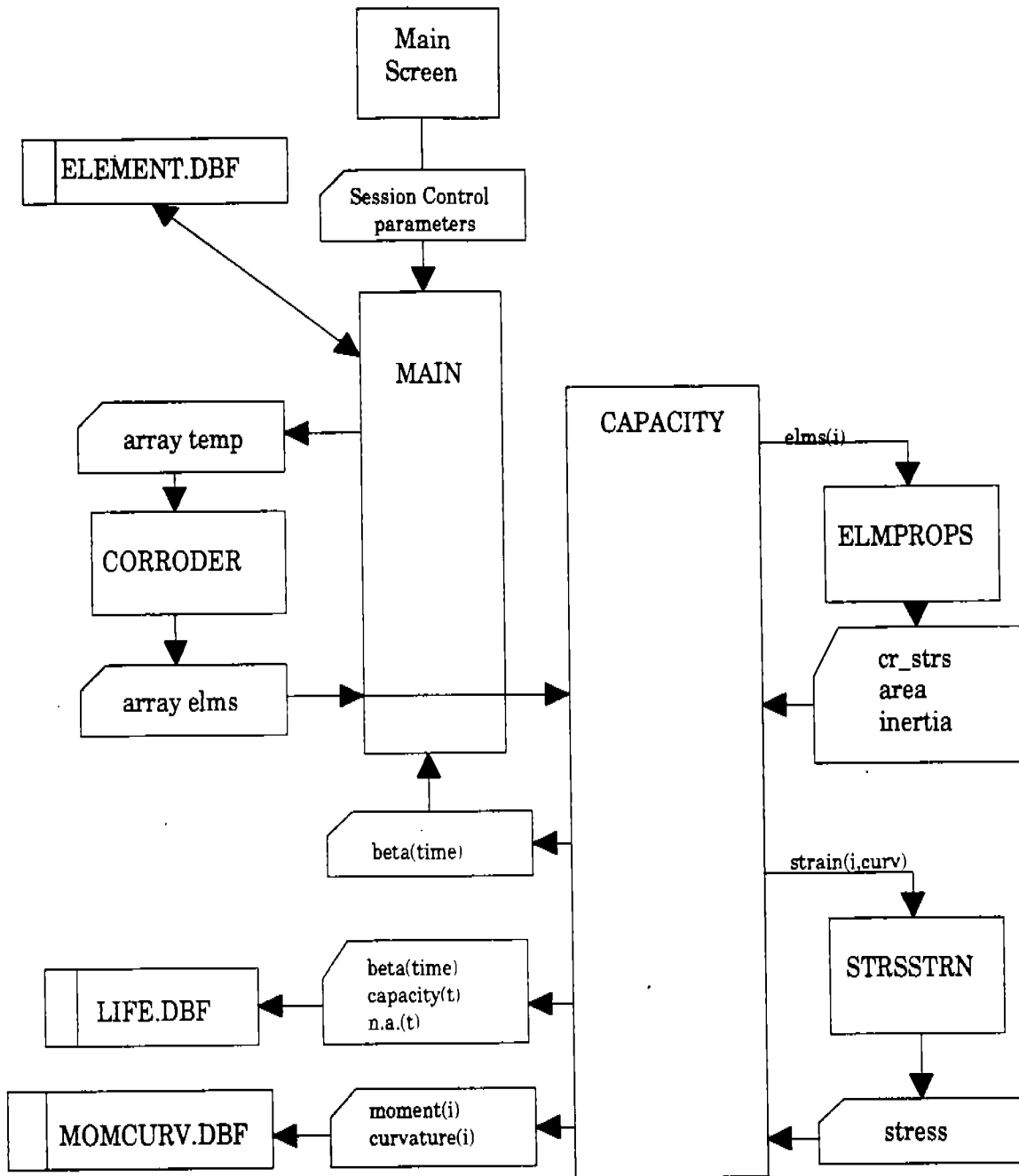

Figure 4.5: General Flow Chart for the Analysis

While the CAPACITY module is fairly robust and genuine in its approach, the ELMPROPS module which calculates the capacity of an element is scarcely more than symbolic and the development of a sophisticated load/endshortening module would add significantly to the value of this program.

5. EXAMPLE APPLICATION

5.1. EXAMPLE VESSEL

The vessel that was chosen for the example application is a 216,000 DWT single bottom VLCC named the *Energy Concentration*. In July of 1980, the *Energy Concentration* suffered a "broken back" while discharging oil at the Mobil Terminal in Rotterdam. While there were many factors that lead up to the ultimate collapse, the fact that the VLCC was ten years old at the time suggests that wastage of the structure, particularly the bottom plating and longitudinals, must have played an important role. In addition to presenting an interesting corrosion study, this event was extensively studied by Rutherford and Caldwell [Ultimate Longitudinal Strength of Ships: a Case Study] the results of which can be used as a comparison.

A brief description of the physical characteristics of the *Energy Concentration* is given in the following tables and figures.

General Particulars

L.O.A.	326.75 m
L.B.P.	313.0 m
Breadth (mld)	48.19 m
Depth (mld)	25.2 m
Gross tonnage	98,894 tons
Deadweight	216,269 tons
Block Coef.	0.809

The overall design and layout of the *Concentration* was typical of VLCC's built around 1970. The cargo section of the hull was divided by two

longitudinal and seven transverse bulkheads, making a total of five center tanks and twelve wing tanks (Fig. 5.1).

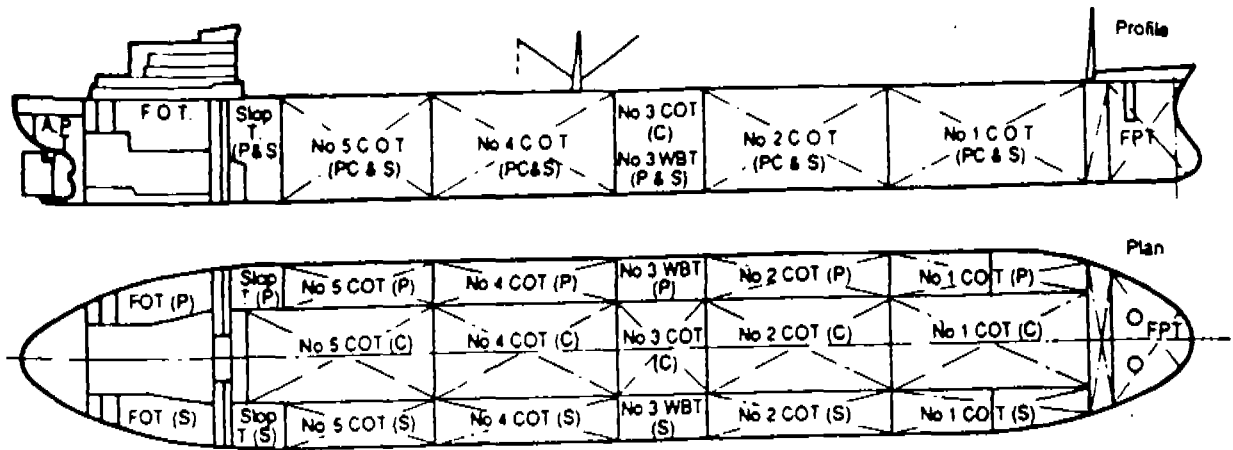

Figure 5.1: General Arrangement (Profile and Plan)

The catastrophic collapse of the *Concentration* occurred around frame 76 where the stillwater bending moment was at its maximum value of roughly 17,940 MNm. Shown in Fig. 5.2 is a section view of the longitudinal structure of this mid body portion of the hull. The bottom, side, deck and longitudinal bulkhead plating are reinforced by closely spaced longitudinal stiffeners. The longitudinal structure is then supported by transverse web frames spaced 5.1 meters apart.

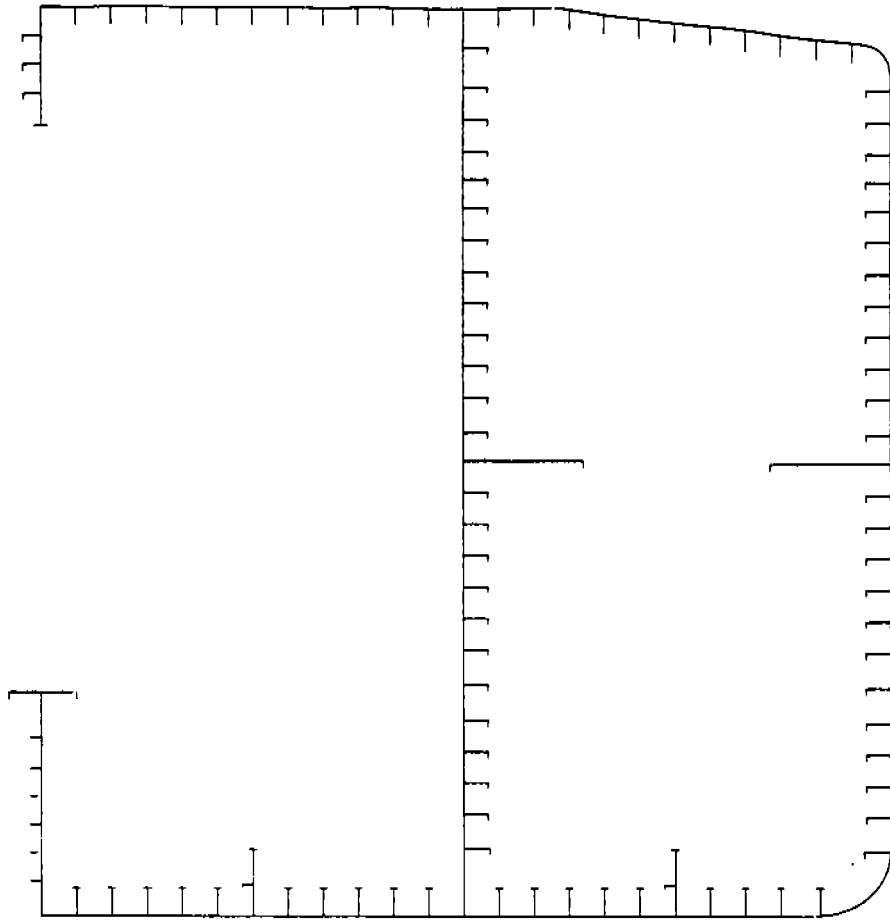

Figure 5.2: Midship Section of the Energy Concentration

For this study, the hull was idealized as a combination of over two hundred plate stiffener element combinations. A full list of the elements that constitute this section is given in the appendix to this report. In the table below are a few examples of the input required to define an element of the cross section.

Element id:	B01S	S17S	D05S
Configuration:			

Plate	plate breadth (mm)	1000	925	1000
	plate thickness (mm)	25	23.5	25.0
	corrosion rate(mm/yr)	0.197	0.051	0.11
Web	web depth (mm)	797	747	480
	web thickness (mm)	15	12.7	32
	corrosion rate(mm/yr)	0.063	0.035	0.063
Flange	flange width (mm)	200	180	-
	flange thickness (mm)	33	25	-
	corrosion rate(mm/yr)	0.053	0.050	-

Material	Type	HTS	MS	HTS
	elastic mod (N/mm ²)	4233	4233	4233
	yield stress (N/mm ²)	350	315	350
	ultimate strs(N/mm ²)	555	525	555

5.2. LOAD CONDITION

The Concentration failed while in port and in the hogging condition. The demand placed on the vessel consisted solely of a hogging still water bending moment. In order to simulate this demand situation for the SMIS calculation, the sagging loads can be left as they were calculated since these represent non-extreme loads, and are unlikely to drive the overall safety index. The hogging vertical wave bending moment can be eliminated by setting its bias factor equal to zero. Finally, the extreme stillwater hog moment of 17,940 MNm can be derived from the "rule based" by assigning an appropriate bias factor. The stillwater hog moment calculated by the SMIS was 5,851 MNm implying a required bias factor of around 3.0.

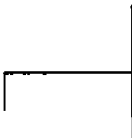
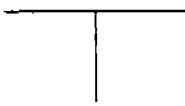
6. RESULTS AND CONCLUSIONS

6.1. RESULTS OF THE EXAMPLE APPLICATION

The ultimate capacity of the Concentration in the hogging mode is shown in Fig. 6.1. The capacity was calculated for each of six time steps ranging from the zero year (as-built) section up until the ten year mark which corresponds to the age of the vessel when it sailed into port for the last time. The horizontal line in each graph represents the extreme stillwater load applied to the reliability calculation.

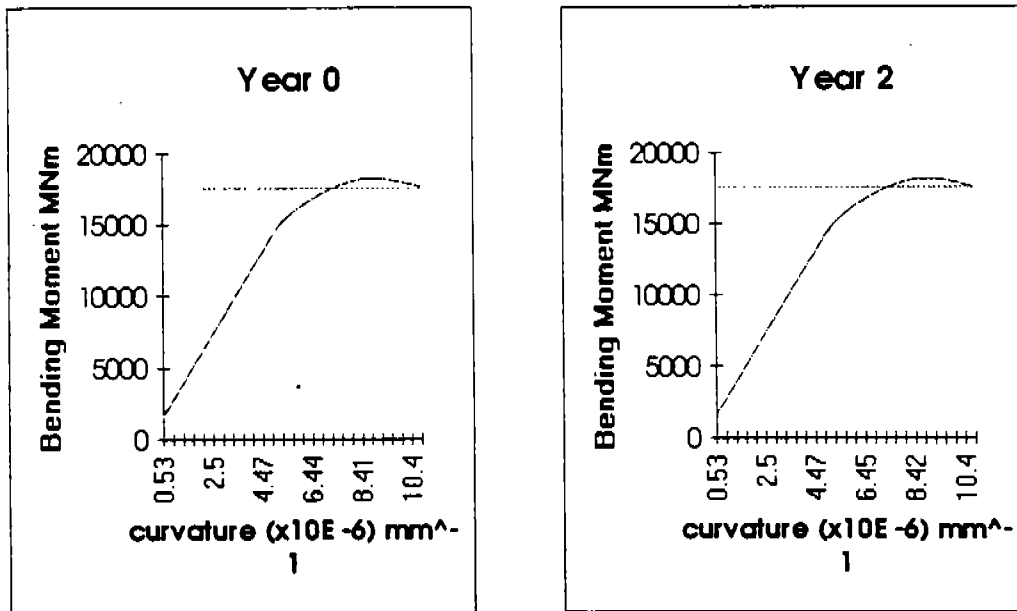

Figure 6.1a: Hogging Moment/Curvature Relations as a Function of Time

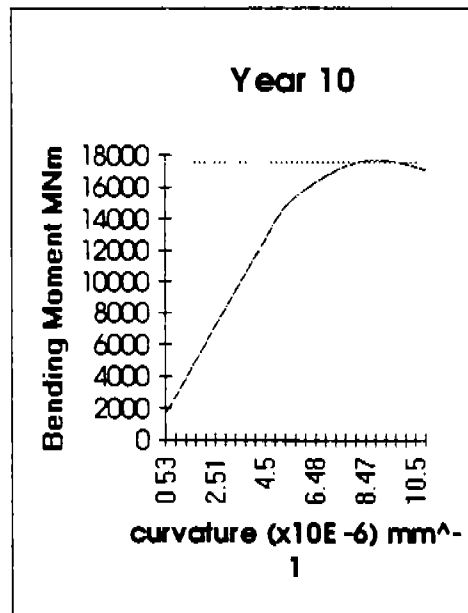
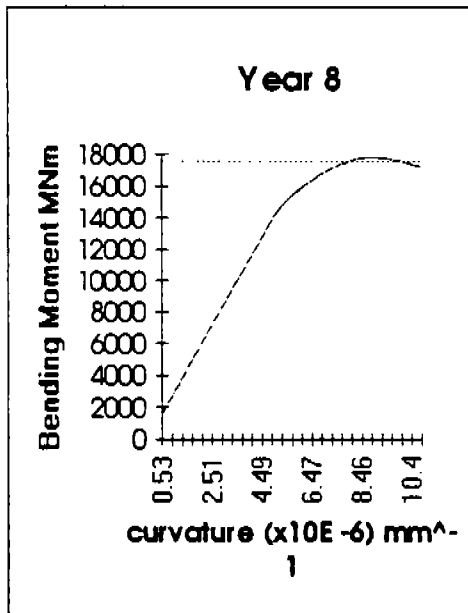
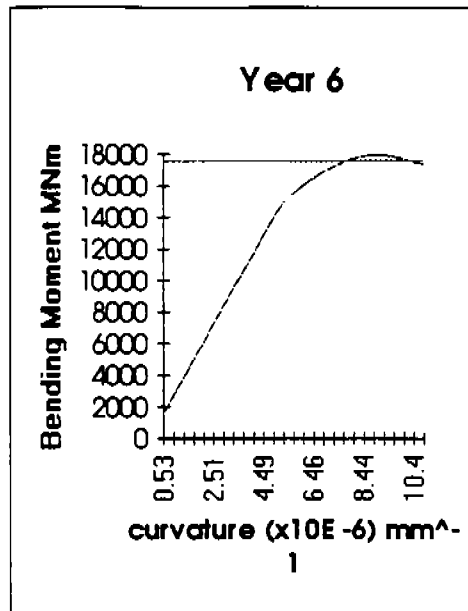
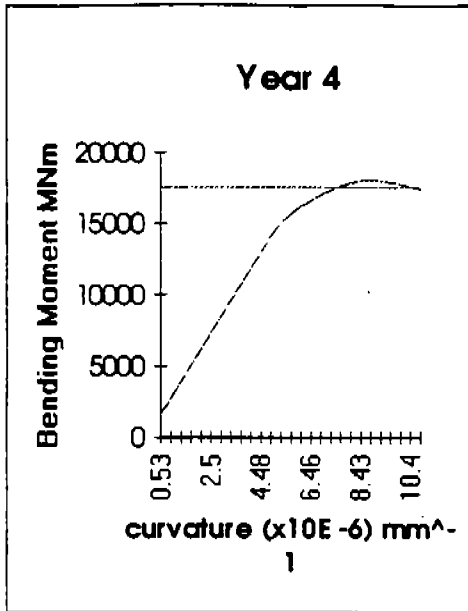

Figure 6.1b: Hogging Moment/Curvature Relations as a Function of Time

84

The capacity of the midship section structure in the hogging mode was found to decline almost linearly with time at a rate of roughly 1,500 MNm/year. This trend is displayed graphically in Fig. 6.2

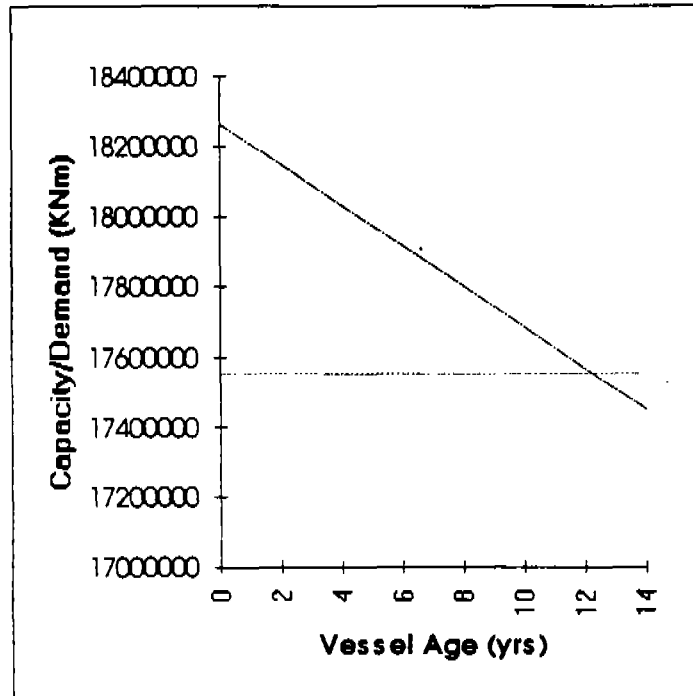

Figure 6.2: The Decline in Ultimate Capacity of the Midship Section

6.2. RELIABILITY OF SAMPLE VESSEL AND CORROSION LIMITS

Presented below is the decline in "beta" over the lifespan of the *Energy Concentration* as calculated by in the example application. The trend that the numbers display illustrates what would be expected. The graph represents a slightly accelerated (i.e. non-linear) decrease in the safety index. This is the result of a higher percentage of elements entering the non-linear regions of their load/end-shortening curves. The non-linearity would be more pronounced if the uncertainty in corrosion rates were included in the model

resulting in a "spreading out" of the probability density function for the ultimate capacity.

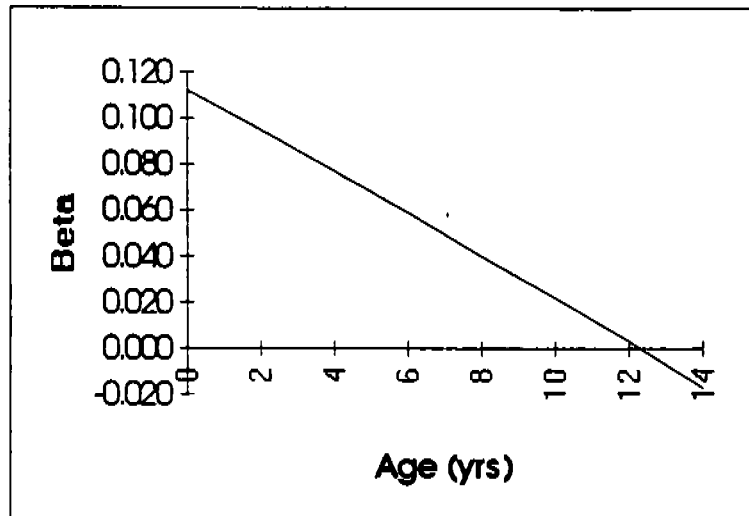

Figure 5.4: Decline in Reliability over Time

6.3. CORROSION LIMITS

While there were many factors involved in the failure of the *Energy Concentration*, clearly the wastage of the internal structure was one of them. The wealth of information surrounding this particular event provided the insight in this case that otherwise would have to come from a very thorough treatment as per the approach outlined in this study. Only a comprehensive treatment of all the major factors involved will lead to accurate predictions of the allowable wastage limits.

In the mean time, with the benefit of hindsight and a historically based estimate of corrosion rates, wastage limits can be assigned to each sub-element of the failed section. Applying a ten year time-until-failure, and assuming that corrosion rates remain constant over the long term, the allowable wastage can be calculated. The results for the bottom shell element presented earlier are as follows:

Subelement	corrosion rate (mm/yr)		time-until failure (yrs)	=	allowable wastage (mm)
Plate	0.197	x	10	=	1.97
Web	0.063	x	10	=	0.63
Flange	0.053	x	10	=	0.53

6.4. RECOMMENDATIONS FOR FUTURE WORK

The goal of this project was to develop a rational approach to the definition of corrosion limits in tankers. The basic framework for an analytical tool that can be used to solve this problem has been laid out in the preceding sections along with an example application to illustrate the procedure. There remains much work to be done in order to implement the ideas presented in this study and create an application that can be used by the industry.

A endeavor such as this one actually involves two disciplines: Naval Architecture and Computer Systems Analysis. In order to develop a working application based on this study, the expertise of both fields are required. Listed below are recommendations for future work in both areas:

6.4.1. Naval Architecture Topics

- **Element Behavior**: Among the many uncertainties involved in the modeling of this problem, the prediction of the individual element behavior plays a very significant role. This uncertainty alone, if not treated properly, could potentially invalidate the results of the reliability calculation. Topics to be considered are: lateral hydrostatic pressure, initial imperfections, and residual stresses.
- **Boundary Conditions and Interaction Between Elements**: The effect that adjacent elements have on each other plays a significant role in the calculation of buckling strength.
- **Loading Module**: A loading module based on ship motion theory needs to be incorporated into the application.

- Uncertainty and Correlation: A comprehensive treatment, module by module, of all the uncertainties involved is crucial to the success and usefulness of the system. This includes modelling correlation between failure modes and correlation between repair times.
- HOE: Some recent work being done in the area of Human and Organizational Errors could be incorporated into the approach.

6.4.2. Computer Systems Topics

- Data Gathering: In order to support all of the aspects of the life assessment procedure, the database must have sufficient and accurate data.
- Data Modeling: This task involves taking the raw data and setting it in a format that can be used by the analytical routines while at the same time providing for the ease of input.
- User Interface: A consistent user interface needs to be designed that will allow a range of users to operate. This includes providing help screens, menu bars, error checking, input (data entry) screens, and output (reporting) screens.

REFERENCES

1. Chen, Y-k; "Corrosion Margins for Oil Tankers." Technical Report SMP-2-2; *Structural Maintenance for New and Existing Ships Project*, 1992
2. Shama, M.A.; "The Cost of Irrationality in Ship Structural Design," PRADS, Tokyo, Oct. 1977
3. Daidola, J.C., Basar, N.S.: "Probabilistic Structural Analysis of Ship Hull Longitudinal Strength"; SSC-301, December 1980
4. Mansour, A.E.; "Methods of Computing the Probability of Failure under Extreme Values of Bending Moment"; *Journal of Ship Research*, Vol. 16, No. 2, June 1972
5. Nikolaidis, E., Kaplan, P.; "Uncertainties in Stress Analysis on Marine Structures" SSC Report SSC-363, April 1991
6. Smith, C. S.; "Influence of Local Compressive Failure on Ultimate Longitudinal Strength of a Ship's Hull," PRADS, Tokyo, Oct. 1977
7. Salvesen, N, Tuck, E.O., Faltinsen, O.; "Ship Motions and Sea Loads";
8. Galambos, T.; Guide to Stability Design Criteria for Metal Structures 4th Edition; John Wiley and Sons, 1976
9. Mansour A.: "A note on the Extreme Wave Load and Associated Probability of Failure"; *Journal of Ship Research*, June 1986
10. Chen, Y-k; "Analysis of Oil Tanker Corrosion Data" Technical Report SMP-2-3; *Structural Maintenance for New and Existing Ships Project*, 1992



11. Schulte-Strathaus, R.; "SMP Tanker Database" Technical Report SMP-1-9; *Structural Maintenance for New and Existing Ships Project*, 1992
12. Dow, R.S., Hugill, R.C., Clark, J.D., Smith, C.S.; "Evaluation of Ultimate Ship Hull Strength"; *Extreme Loads Response Symposium*, Arlington, VA, Oct. 1981
13. Chen, Y-k, Kutt, L.M., Piaszczyk, C.M., Bieniek, M.P.; "Ultimate Strength of Ship Structures," *SNAME Transactions*, Vol.91, 1983, pp 149-168
14. Ostapenko, A.; "Strength of Ship Hull Girders under Moment, Shear, and Torque," *Extreme Loads Response Symposium*, Arlington, VA, Oct. 1981
15. Mansour, A., Yang, J.M., Thayambali, A.; "An Experimental Investigation of Ship Hull Ultimate Strength," *SNAME Annual Meeting Preprints*, San Francisco, CA, Nov. 1990
16. Adamchak, J.C.; "Design Equations for Tripping of Stiffeners under In-plane and Lateral Loads," Report DTNSRDC-79/064, Oct. 1979
17. Bea, R.G., "Marine Structural Integrity Programs - MSIP," Ship Structure Committee Report, Nov. 1991
18. Classification Notes; "Buckling Strength Analysis of Mobile Offshore Units," Det Norske Veritas, June 1984
19. Pollard, R.R., Bea, R.G.; "Evaluation of Corrosion Damage in Crude and Product Carriers," Technical Report SMP-2-1, *Structural Maintenance for New and Existing Ships Project*, 1991
20. Fox Software, Inc.; FoxPro Getting Started. Fox Holdings, Inc.
21. Fox Software, Inc.; FoxPro Developer's Guide. Fox Holdings, Inc.
22. Fox Software, Inc.; FoxPro Commands & Functions. Fox Holdings, Inc.
23. Fox Software, Inc.; FoxPro Interface Guide. Fox Holdings, Inc.

24. Zienkiewicz, O.C.; The Finite Element Method (Third Edition); McGraw-Hill 1977
25. Ogilvie, T.F.; "On the Computation of Wave Induced Bending and Torsional Moments", Journal of Ship Research, Sep. 1971

APPENDIX A: SOURCE CODE FOR SMIS

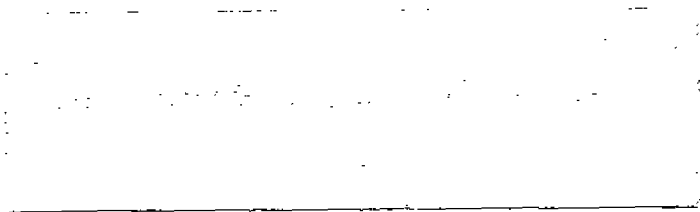

```

* *****
* *
* * 11/30/93      ANALYSIS.SPR      22:35:45
* *
* *****
* *
* * Author's Name
* *
* * Copyright (c) 1993 Company Name
* * Address
* * City, Zip
* *
* * Description:
* * This program was automatically generated by GENSCRN.
* *
* *****

```

```

#REGION 0
REGIONAL m.currarea, m.talkstat, m.compstat

```

```

IF SET("TALK") = "ON"
    SET TALK OFF
    m.talkstat = "ON"

```

```

ELSE
    m.talkstat = "OFF"

```

```

ENDIF
m.compstat = SET("COMPATIBLE")
SET COMPATIBLE FOXPLUS

```

```

m.rborder = SET("READBORDER")
SET READBORDER ON

```

```

m.currarea = SELECT()

```

```

* *****
* *
* * ANALYSIS/Windows Databases, Indexes, Relations
* *
* *****
*

```

```

IF USED("class")
    SELECT class
    SET ORDER TO TAG "class_id"
ELSE
    SELECT 0
    USE (LOCFILE("\smis\dbfs\class.dbf", "DBF", "Where is class?"));
    AGAIN ALIAS class ;
    ORDER TAG "class_id"
ENDIF

```

```

IF USED("section")

```

```

        SELECT section
        SET ORDER TO TAG "sect_id"
ELSE
    SELECT 0
    USE (LOCFILE("\smis\dbfs\section.dbf", "DBF", "Where is section?"));
        AGAIN ALIAS section ;
        ORDER TAG "sect_id"
ENDIF

IF USED("element")
    SELECT element
    SET ORDER TO TAG "elm_id"
ELSE
    SELECT 0
    USE (LOCFILE("\smis\dbfs\element.dbf", "DBF", "Where is element?"));
        AGAIN ALIAS element ;
        ORDER TAG "elm_id"
ENDIF

IF USED("steel")
    SELECT steel
    SET ORDER TO TAG "steel_id"
ELSE
    SELECT 0
    USE (LOCFILE("\smis\dbfs\steel.dbf", "DBF", "Where is steel?"));
        AGAIN ALIAS steel ;
        ORDER TAG "steel_id"
ENDIF

IF USED("life")
    SELECT life
    SET ORDER TO 0
ELSE
    SELECT 0
    USE (LOCFILE("\smis\dbfs\life.dbf", "DBF", "Where is life?"));
        AGAIN ALIAS life ;
        ORDER 0
ENDIF

IF USED("momcurv")
    SELECT momcurv
    SET ORDER TO 0
ELSE
    SELECT 0
    USE (LOCFILE("\smis\dbfs\momcurv.dbf", "DBF", "Where is momcurv?"));
        AGAIN ALIAS momcurv ;
        ORDER 0
ENDIF

SELECT class

```

```

* *****
* *

```



```

* *      Windows Window definitions
* *
* *****
*

```

```

IF NOT WEXIST("smis");
  OR UPPER(WTTITLE("SMIS")) == "SMIS.PJX" ;
  OR UPPER(WTTITLE("SMIS")) == "SMIS.SCX" ;
  OR UPPER(WTTITLE("SMIS")) == "SMIS.MNX" ;
  OR UPPER(WTTITLE("SMIS")) == "SMIS.PRG" ;
  OR UPPER(WTTITLE("SMIS")) == "SMIS.FRX" ;
  OR UPPER(WTTITLE("SMIS")) == "SMIS.QPR"
  DEFINE WINDOW smis ;
    AT 3.083, 8.750 ;
    SIZE 24.538,100.200 ;
    TITLE "Section Analysis" ;
    FONT "MS Sans Serif", 8 ;
    FLOAT ;
    NOCLOSE ;
    MINIMIZE ;
    SYSTEM
ENDIF

```

```

* *****
* *
* *      ANALYSIS/Windows Setup Code - SECTION 2
* *
* *****
*

```

```

#REGION 1
PUBLIC m.class_id, m.sect_id, m.ds_life,m.ntimes,m.ds_load,;
      m.loadbias,m.loadcov
DIMENSION sections(40,2)

SET UDFPARMS TO REFERENCE

STORE '' TO sections

SELECT DISTINCT ALLTRIM(UPPER(class.classname)), class.class_id;
FROM CLASS;
ORDER BY class.classname;
INTO ARRAY classes

m.betamin = 0.0
m.ntimes = 0.0

m.swhog = 0.0
m.b_swhog = 1.0
m.cov_swhog = 0.2
m.vwhog = 0.0
m.b_vwhog = 1.0
m.cov_vwhog = 0.2

```

m.swsag = 0.0
m.b_swsag = 1.0
m.cov_swsag = 0.2
m.vwsag = 0.0
m.b_vwsag = 1.0
m.cov_vwsag = 0.2

m.session = ''

```
* *****  
* *  
* *      ANALYSIS/Windows Screen Layout  
* *  
* *****  
*
```

```
#REGION.1  
IF WVISIBLE("smis")  
    ACTIVATE WINDOW smis SAME  
ELSE  
    ACTIVATE WINDOW smis NOSHOW  
ENDIF  
@ 3.769,57.600 SAY "Minimum Beta level:" + CHR(13) + ;  
    "" + CHR(13) + ;  
    "Time Step (in years):" ;  
    SIZE 3.000,19.800, 0.000 ;  
    FONT "MS Sans Serif", 8 ;  
    STYLE "T"  
@ 1.923,57.600 SAY "SESSION PARAMETERS" ;  
    FONT "MS Sans Serif", 8 ;  
    STYLE "BT"  
@ 3.769,4.200 SAY "Vessel Class:" ;  
    FONT "MS Sans Serif", 8 ;  
    STYLE "T"  
@ 5.615,4.200 SAY "Section:" ;  
    FONT "MS Sans Serif", 8 ;  
    STYLE "T"  
@ 1.923,4.800 SAY "SECTION IDENTIFICATION" ;  
    FONT "MS Sans Serif", 8 ;  
    STYLE "BT"  
@ 13.923,4.800 SAY "Mean:" ;  
    FONT "MS Sans Serif", 8 ;  
    STYLE "T"  
@ 15.769,4.800 SAY "Bias:" + CHR(13) + ;  
    "" + CHR(13) + ;  
    "Coef. of Var.:" ;  
    SIZE 3.000,13.000, 0.000 ;  
    FONT "MS Sans Serif", 8 ;  
    STYLE "T"  
@ 9.308,45.600 SAY "Design LOADS:" ;  
    FONT "MS Sans Serif", 8 ;  
    STYLE "BT"
```

```

@ 8.308,2.600 TO 8.308,98.200 ;
  PEN 1, 8 ;
  STYLE "1"
@ 12.000,55.200 TO 19.462,55.200 ;
  PEN 1, 8
@ 1.000,52.800 TO 8.385,52.800 ;
  PEN 1, 8
@ 19.385,3.000 TO 19.385,98.600 ;
  PEN 1, 8 ;
  STYLE "1"
@ 12.615,23.600 SAY "SWBM"          VWBM" ;
  FONT "MS Sans Serif", 8 ;
  STYLE "T"
@ 12.615,64.800 SAY "SWBM"          VWBM" ;
  FONT "MS Sans Serif", 8 ;
  STYLE "T"
@ 3.692,21.600 GET m.which_class ;
  PICTURE "@^" ;
  FROM classes ;
  SIZE 1.538,22.167 ;
  DEFAULT 1 ;
  FONT "MS Sans Serif", 8 ;
  STYLE "B" ;
  WHEN _qld1cflsi() ;
  VALID _qld1cfmvc()
@ 5.538,21.600 GET m.which_sect ;
  PICTURE "@^" ;
  FROM sections ;
  SIZE 1.538,22.167 ;
  DEFAULT 1 ;
  FONT "MS Sans Serif", 8 ;
  STYLE "B" ;
  WHEN _qld1cfni6() ;
  VALID _qld1cfnmt() ;
  DISABLE
@ 3.769,79.600 GET m.betamin ;
  SIZE 1.000,8.800 ;
  DEFAULT 0 ;
  FONT "MS Sans Serif", 8 ;
  PICTURE "@K 99.999"
@ 5.615,82.000 GET m.timestep ;
  SIZE 1.000,6.400 ;
  DEFAULT 0 ;
  FONT "MS Sans Serif", 8 ;
  PICTURE "@K"
@ 13.923,22.000 GET m.swhog ;
  SIZE 1.000,13.600 ;
  DEFAULT 0 ;
  FONT "MS Sans Serif", 8 ;
  PICTURE "@KZ 999999999.9" ;
  DISABLE
@ 15.769,24.400 GET m.b_swhog ;
  SIZE 1.000,6.400 ;
  DEFAULT " " ;

```



FONT "MS Sans Serif", 8 ;
PICTURE "@K" ;
DISABLE
@ 17.615,24.400 GET m.cov_swhog ;
SIZE 1.000,6.400 ;
DEFAULT " " ;
FONT "MS Sans Serif", 8 ;
PICTURE "@K" ;
DISABLE
@ 13.923,38.800 GET m.vwhog ;
SIZE 1.000,13.600 ;
DEFAULT 0 ;
FONT "MS Sans Serif", 8 ;
PICTURE "@KZ 99999999.9" ;
DISABLE
@ 15.769,41.200 GET m.b_vwhog ;
SIZE 1.000,6.400 ;
DEFAULT " " ;
FONT "MS Sans Serif", 8 ;
PICTURE "@K" ;
DISABLE
@ 17.615,41.200 GET m.cov_vwhog ;
SIZE 1.000,6.400 ;
DEFAULT " " ;
FONT "MS Sans Serif", 8 ;
PICTURE "@K" ;
DISABLE
@ 13.923,62.800 GET m.swsag ;
SIZE 1.000,13.600 ;
DEFAULT 0 ;
FONT "MS Sans Serif", 8 ;
PICTURE "@KZ 999999999.9" ;
DISABLE
@ 15.769,65.200 GET m.b_swsag ;
SIZE 1.000,6.400 ;
DEFAULT " " ;
FONT "MS Sans Serif", 8 ;
PICTURE "@K" ;
DISABLE
@ 17.615,65.200 GET m.cov_swsag ;
SIZE 1.000,6.400 ;
DEFAULT " " ;
FONT "MS Sans Serif", 8 ;
PICTURE "@K" ;
DISABLE
@ 13.923,79.600 GET m.vwsag ;
SIZE 1.000,13.600 ;
DEFAULT 0 ;
FONT "MS Sans Serif", 8 ;
PICTURE "@KZ 999999999.9" ;
DISABLE
@ 15.769,82.000 GET m.b_vwsag ;
SIZE 1.000,6.400 ;
DEFAULT " " ;

```
IF USED("class")
    SELECT class
    USE
ENDIF
```

```
IF USED("section")
    SELECT section
    USE
ENDIF
```

```
IF USED("element")
    SELECT element
    USE
ENDIF
```

```
IF USED("steel")
    SELECT steel
    USE
ENDIF
```

```
IF USED("life")
    SELECT life
    USE
ENDIF
```

```
IF USED("momcurv")
    SELECT momcurv
    USE
ENDIF
```

```
SELECT (m.currarea)
```

```
#REGION 0
```

```
SET READBORDER &rborder
```

```
IF m.talkstat = "ON"
    SET TALK ON
ENDIF
```

```
IF m.compstat = "ON"
    SET COMPATIBLE ON
ENDIF
```

```
*****
*
*      ANALYSIS/Windows Cleanup Code
*
*****
*
```

```
#REGION 1
```

```
        AND Steel.steel_id = Element.steel_id;
        AND Section.sect_id = m.sect_id;
INTO ARRAY temp
```

```
m.count = ALEN(temp)
n_elms = INT(m.count/16)
```

```
m.step = 1
```

```
DO WHILE m.beta > m.Betamin
```

```
    dimension elms(n_elms,16)
```

```
    lastbeta = m.beta
```

```
    m.year = (m.step-1)*m.timestep
```

```
    DO CORRODER
```

```
    DO CAPACITY
```

```
    m.caphog = m.caphog/1000000
    m.capsag = m.capsag/1000000
```

```
    m.betahog = (m.caphog - m.dmdhog);
                /sqrt((cov_caphog*m.caphog)^2 + vdmdhog^2)
```

```
    m.betasag = (m.capsag - m.dmdsag);
                /sqrt((cov_capsag*m.capsag)^2 + vdmdsag^2)
```

```
    m.beta = betahog
```

```
    SELECT life
```

```
    APPEND BLANK
    GATHER MEMVAR
```

```
    m.step = m.step + 1
```

```
ENDDO
```

```
m.step = m.step - 1
```

```
TTF = (m.step-1)*m.timestep + (m.Betamin-lastbeta) *;
      m.timestep/(m.beta-lastbeta)
```

```
? TTF
```

```
WAIT WINDOW 'YOU WON'
```

```
* Set up wastage limit report
```

```
*****
*
```

```
elms(j,10) = temp(i+12)
elms(j,11) = temp(i+13)
elms(j,12) = temp(i+14)
elms(j,13) = temp(i+15)
```

```
i = i + 16
j = j + 1
```

```
IF i > m.count
  done = .T.
ENDIF
```

```
ENDDO
```

```
RETURN
```

```
*
***** END *****
```

```
*****
```

```
*
PROCEDURE CAPACITY
*****
```

```
* Input:
*       elms array - contains the element specific info for the section
*       m.count    - length of elms array
```

```
* Output:
*       Mmt_crv    - Moment vs Curvature array
```

```
* -----
* Called by: ANALYSIS
```

```
* Calls:      ELMPROPS
*             STRSSTRN
```

```
* -----
* DIMENSION el_curv(n_elms), strss(n_elms)
* Initialize...
```

```
m.sect_area = 0.0
y_times_a = 0.0
I_nodes = 0.0
cr_strs = 0.0
I_node = 0.0
area = 0.0
```



- * Find elastic limit curvature, curvature at which first element reaches its elastic limit, stress y_strs

```

elaslim = 10.                && impossibly high
y_strn = 0.000000000000
el_curv = 0.000000000000

```

- * calculate elastic limit curvature in the hogging condition

```

FOR i = 1 TO n_elms

  y_na = elms(i,9) - m.na
  y_strn = elms(i,12)/elms(i,10)
  IF elms(i,14) < elms(i,12)
    IF y_na < 0
      el_curv = elms(i,14)/(elms(i,10)*y_na)
    ELSE
      el_curv = y_strn/y_na
    ENDIF
  ELSE
    el_curv = y_strn/y_na
  ENDIF

  elaslim = MIN(ABS(el_curv),elaslim)
ENDFOR

done = .F.
j=2
curvtr(j) = elaslim
stress = 0.0

postj = 5

DO WHILE .NOT. done

  k = j-1
  forcesum = 0.0                && reset values
  ea_sum = 0.0
  moment(j) = 0.0

  FOR i = 1 TO n_elms
    strain = curvtr(j)*(elms(i,9) - m.na)
    DO strstr WITH elms(i,10),elms(i,11),elms(i,12);
      ,elms(i,14),strain
    strss(i) = stress
    forcesum = forcesum + stress*elms(i,15)
    ea_sum = ea_sum + elms(i,10)*elms(i,15)
  ENDFOR

  IF j > 2
    shift = forcesum/(ea_sum*curvtr(j))
  ELSE
    shift = 0.0

```



```

FOR i = 1 TO n_elms

  y_na = elms(i,9) - m.na
  y_strn = elms(i,12)/elms(i,10)
  IF elms(i,14) < elms(i,12)
    IF y_na > 0
      el_curv = elms(i,14)/(elms(i,10)*y_na)
    ELSE
      el_curv = y_strn/y_na
    ENDIF
  ELSE
    el_curv = y_strn/y_na
  ENDIF

  elaslim = -MIN(ABS(el_curv),ABS(elaslim))

ENDFOR

done = .F.
j=2
curvtr(j) = elaslim
stress = 0.0

forcesum = 0.0
ea_sum = 0.0
postj = 5

DO WHILE .NOT. done

  k = j-1
  forcesum = 0.0
  ea_sum = 0.0
  moment(j) = 0.0
  && reset values

  FOR i = 1 TO n_elms
    strain = curvtr(j)*(elms(i,9) - m.na)
    DO strstr WITH elms(i,10),elms(i,11),elms(i,12);
      ,elms(i,14),strain
    strss(i) = stress
    forcesum = forcesum + stress*elms(i,15)
    ea_sum = ea_sum + elms(i,10)*elms(i,15)
  ENDFOR

  shift = forcesum/(ea_sum*curvtr(j))

  m.na = m.na + shift
  moment(j) = 0.0
  FOR i = 1 TO n_elms
    moment(j) = moment(j) +;
      strss(i)*elms(i,15)*(elms(i,9)-m.na)
  ENDFOR

  m.momnt = moment(j)
  m.curvtr = curvtr(j)

```

```

      m.u_strs,m.y_strs,m.poisson
*
last = 0.0
*
Calculate critical stress for plate between stiffeners

kD = 4*m.elasmod*m.pt^3/(12*(1-m.poisson^2))
plt_cr = kD*PI()^2/(m.pt*m.pb^2)

*
done = .F.
kbeta = (pb/pt)*sqrt(u_strs/elasmod)
pbe = m.pb

area = m.pb*m.pt + m.wd*m.wt + m.fb*m.ft

*
Calculate column (Euler) buckling stress

e_area = m.pb*m.pt + m.wd*m.wt + m.fb*m.ft

centroid = (0.5*m.wd^2*m.wt + m.fb*m.ft*m.wd)/e_area

I_cent = (m.pb*m.pt^3 + m.wt*m.wd^3 + m.fb*m.ft^3)/12 + ;
          m.pb*m.pt*centroid^2 + m.wd*m.wt*(0.5*m.wd - centroid)^2;
          + m.fb*m.ft*(m.wd - centroid)^2

gyradius = SQRT(I_cent/e_area)

col_cr = elasmod*(PI()*gyradius/m.space)^2

*
Calculate I_node

cr_strs = 1.8*col_cr

I_plate = (m.pt*m.pb^3/12)*SIN(m.theta)^2
I_web = m.wt*m.wd^3*COS(m.theta)^2/3
I_flg = (m.ft*m.fb^3/12)*SIN(m.theta)^2

I_node = I_plate + (I_web + m.wd*m.wt*(0.5*m.wd*COS(m.theta))^2);
          + (I_flg + m.ft*m.fb*(m.wd*COS(m.theta))^2)

RETURN

*
***** END *****

*****

*
Procedure STRSSTRN
*
*****

```

```

        CR_STRN = U_STRN
        STRAIN = -STRAIN          && one-sided material stress-strain crv
ELSE
    TENSION = .F.
ENDIF

IF (STRAIN > CR_STRN)
    IF (HARDSPOT)
        STRESS = m.U_STRS
    ELSE
        STRESS = CR_STRS + (CR_STRN - STRAIN)*0.1*m.ELASMOD
    ENDIF
ELSE
    IF (STRAIN <= Y_STRN)
        STRESS = STRAIN*m.ELASMOD.
    ELSE
        IF (STRAIN > Y_STRN .and. STRAIN < U_STRN)
            EXPON1 = EXP((STRAIN - Y_STRN)/K1)
            STRESS = (m.U_STRS/K2)*EXPON1/(1+EXPON1/k2)
        ELSE
            STRESS = m.U_STRS
        ENDIF
    ENDIF
ENDIF

IF TENSION
    STRESS = -STRESS
ENDIF

*
RETURN

```

```

* *****
* *
* * _QLD1CFLSI      m.which_class WHEN
* *
* * Function Origin:
* *
* * From Platform:   Windows
* * From Screen:    ANALYSIS,   Record Number: 22
* * Variable:       m.which_class
* * Called By:      WHEN Clause
* * Snippet Number: 1
* *
* *****

```

```

FUNCTION _qld1cflsi  && m.which_class WHEN
#REGION 1
m.which_class = 1

```

```

* *****
* *
* * _QLD1CFMVC      m.which_class VALID
* *
* * Function Origin:

```

```
WHERE section.class_id = m.class_id;
ORDER BY sect_id;
INTO ARRAY sections
```

```
SHOW GET m.which_sect ENABLE
_CUROBJ = OBJNUM(which_sect)
```

* find the correct class record and point to it

```

* .....
* *
* * _QLD1CFNI6      m.which_sect WHEN
* *
* * Function Origin:
* *
* * From Platform:  Windows
* * From Screen:   ANALYSIS, Record Number: 23
* * Variable:      m.which_sect
* * Called By:     WHEN Clause
* * Snippet Number: 3
* *
* .....

```

```
FUNCTION _qld1cfni6  && m.which_sect WHEN
#REGION 1
m.which_sect = 1
```

```

* .....
* *
* * _QLD1CFNMT      m.which_sect VALID
* *
* * Function Origin:
* *
* * From Platform:  Windows
* * From Screen:   ANALYSIS, Record Number: 23
* * Variable:      m.which_sect
* * Called By:     VALID Clause
* * Snippet Number: 4
* *
* .....

```

```
FUNCTION _qld1cfnmt  && m.which_sect VALID
#REGION 1
m.sect_id = sections(m.which_sect,2)
```

```

* .....
* *
* * _QLD1CFOOM      m.begin VALID
* *
* * Function Origin:
* *

```

APPENDIX B: SECTION IDEALIZATION TABLE

ELM ID	PB	PT	PR	WD	WT	WR	FB	FT	FR	Y NODE	THETA	STEEL ID
B01P	1000.0	25.0	0.197	797.0	15.0	0.063	200.0	33.0	0.053	0.125	0.00	2222
B02P	1000.0	25.0	0.197	797.0	15.0	0.063	200.0	33.0	0.053	0.125	0.00	2222
B03P	1000.0	25.0	0.197	797.0	15.0	0.063	200.0	33.0	0.053	0.125	0.00	2222
B04P	1000.0	25.0	0.197	797.0	15.0	0.063	200.0	33.0	0.053	0.125	0.00	2222
B05P	1000.0	25.0	0.197	797.0	15.0	0.063	200.0	33.0	0.053	0.125	0.00	2222
B05S	1000.0	25.0	0.197	797.0	15.0	0.063	200.0	33.0	0.053	0.125	0.00	2222
B06P	1000.0	25.0	0.197	797.0	15.0	0.063	200.0	33.0	0.053	0.125	0.00	2222
B06S	1000.0	25.0	0.197	797.0	15.0	0.063	200.0	33.0	0.053	0.125	0.00	2222
B07P	1000.0	25.0	0.197	797.0	15.0	0.063	200.0	33.0	0.053	0.125	0.00	2222
B07S	1000.0	25.0	0.197	797.0	15.0	0.063	200.0	33.0	0.053	0.125	0.00	2222
B08P	1000.0	25.0	0.197	797.0	15.0	0.063	200.0	33.0	0.053	0.125	0.00	2222
B08S	1000.0	25.0	0.197	797.0	15.0	0.063	200.0	33.0	0.053	0.125	0.00	2222
B09P	1000.0	25.0	0.197	797.0	15.0	0.063	200.0	33.0	0.053	0.125	0.00	2222
B09S	1000.0	25.0	0.197	797.0	15.0	0.063	200.0	33.0	0.053	0.125	0.00	2222
B10P	1000.0	25.0	0.197	797.0	15.0	0.063	200.0	33.0	0.053	0.125	0.00	2222
B10S	1000.0	25.0	0.197	797.0	15.0	0.063	200.0	33.0	0.053	0.125	0.00	2222
B11P	1000.0	25.0	0.197	797.0	15.0	0.063	200.0	33.0	0.053	0.125	0.00	2222
B11S	1000.0	25.0	0.197	797.0	15.0	0.063	200.0	33.0	0.053	0.125	0.00	2222
B12P	1000.0	25.0	0.197	797.0	15.0	0.063	200.0	33.0	0.053	0.125	0.00	2222
B12S	1000.0	25.0	0.197	797.0	15.0	0.063	200.0	33.0	0.053	0.125	0.00	2222
B13P	1000.0	25.0	0.197	797.0	15.0	0.063	200.0	33.0	0.053	0.125	0.00	2222
B13S	1000.0	25.0	0.197	797.0	15.0	0.063	200.0	33.0	0.053	0.125	0.00	2222
B14P	1000.0	25.0	0.197	797.0	15.0	0.063	200.0	33.0	0.053	0.125	0.00	2222
B14S	1000.0	25.0	0.197	797.0	15.0	0.063	200.0	33.0	0.053	0.125	0.00	2222
B15P	1000.0	25.0	0.197	797.0	15.0	0.063	200.0	33.0	0.053	0.125	0.00	2222
B15S	1000.0	25.0	0.197	797.0	15.0	0.063	200.0	33.0	0.053	0.125	0.00	2222
B16P	1000.0	25.0	0.197	797.0	15.0	0.063	200.0	33.0	0.053	0.125	0.00	2222
B16S	1000.0	25.0	0.197	797.0	15.0	0.063	200.0	33.0	0.053	0.125	0.00	2222
B17P	1000.0	25.0	0.197	797.0	15.0	0.063	200.0	33.0	0.053	0.125	0.00	2222
B17S	1000.0	25.0	0.197	797.0	15.0	0.063	200.0	33.0	0.053	0.125	0.00	2222
B18P	1000.0	25.0	0.197	797.0	15.0	0.063	200.0	33.0	0.053	0.125	0.00	2222
B18S	1000.0	25.0	0.197	797.0	15.0	0.063	200.0	33.0	0.053	0.125	0.00	2222
B19P	950.0	18.0	0.051	297.0	11.5	0.035	100.0	16.0	0.050	950.000	1.07	2222
B19S	950.0	18.0	0.051	297.0	11.5	0.035	100.0	16.0	0.050	950.000	1.07	2222
B20P	425.0	25.0	0.035	475.0	18.0	0.051	0.0	0.0	0.000	1900.000	3.14	2222
B20S	425.0	25.0	0.035	475.0	18.0	0.051	0.0	0.0	0.000	1900.000	3.14	2222
B21P	950.0	18.0	0.051	297.0	11.5	0.035	100.0	16.0	0.050	950.000	1.07	2222
B21S	950.0	18.0	0.051	297.0	11.5	0.035	100.0	16.0	0.050	950.000	1.07	2222
B22P	370.0	16.0	0.035	475.0	18.0	0.051	0.0	0.0	0.000	1900.000	3.14	2222
B22S	370.0	16.0	0.035	475.0	18.0	0.051	0.0	0.0	0.000	1900.000	3.14	2222
D01P	1000.0	25.0	0.110	480.0	32.0	0.063	0.0	0.0	0.000	25800.000	3.14	2222
D01S	1000.0	25.0	0.110	480.0	32.0	0.063	0.0	0.0	0.000	25800.000	3.14	2222
D02P	1000.0	25.0	0.110	480.0	32.0	0.063	0.0	0.0	0.000	25800.000	3.14	2222

108 A11