

**SSC-386**

**SHIP MAINTENANCE PROJECT**

Volume 4

*Durability Considerations*

This document has been approved  
for public release and sale; its  
distribution is unlimited

**SHIP STRUCTURE COMMITTEE**

**1995**

1410

SHIP STRUCTURE COMMITTEE

The SHIP STRUCTURE COMMITTEE is constituted to prosecute a research program to improve the hull structures of ships and other marine structures by an extension of knowledge pertaining to design, materials, and methods of construction.

RADM J. C. Card, USCG (Chairman)  
Chief, Office of Marine Safety, Security  
and Environmental Protection  
U. S. Coast Guard

Mr. Thomas H. Peirce  
Marine Research and Development  
Coordinator  
Transportation Development Center  
Transport Canada

Mr. Edwin B. Schimler  
Associate Administrator for Ship-  
building and Technology Development  
Maritime Administration

Dr. Donald Liu  
Senior Vice President  
American Bureau of Shipping

Mr. Robert McCarthy  
Director, Survivability and Structural  
Integrity Group (SEA O3P)  
Naval Sea Systems Command

Mr. Thomas Connors  
Acting Director of Engineering (N7)  
Military Sealift Command

Dr. Ross Graham  
Head, Hydronautics Section  
Defence Research Establishment-Atlantic

EXECUTIVE DIRECTOR

CDR Stephen E. Sharpe, USCG  
U. S. Coast Guard

CONTRACTING OFFICER TECHNICAL REPRESENTATIVE

Mr. William J. Siekierka  
Naval Sea Systems Command

SHIP STRUCTURE SUBCOMMITTEE

The SHIP STRUCTURE SUBCOMMITTEE acts for the Ship Structure Committee on technical matters by providing technical coordination for determining the goals and objectives of the program and by evaluating and interpreting the results in terms of structural design, construction, and operation.

MILITARY SEALIFT COMMAND

Mr. Robert E. Van Jones (Chairman)  
Mr. Rickard A. Anderson  
Mr. Michael W. Touma  
Mr. Jeffrey E. Beach

MARITIME ADMINISTRATION

Mr. Frederick Seibold  
Mr. Richard P. Voelker  
Mr. Chao H. Lin  
Dr. Walter M. Maclean

U. S. COAST GUARD

CAPT George Wright  
Mr. Walter Lincoln  
Mr. Rubin Sheinberg

AMERICAN BUREAU OF SHIPPING

Mr. Glenn Ashe  
Mr. John F. Conlon  
Mr. Phillip G. Rynn  
Mr. William Hanzelek

NAVAL SEA SYSTEMS COMMAND

Mr. W. Thomas Packard  
Mr. Charles L. Null  
Mr. Edward Kadala  
Mr. Allen H. Engle

TRANSPORT CANADA

Mr. John Grinstead  
Mr. Ian Bayly  
Mr. David L. Stocks  
Mr. Peter Timonin

DEFENCE RESEARCH ESTABLISHMENT ATLANTIC

Dr. Neil Pegg  
LCDR Stephen Gibson  
Dr. Roger Hollingshead  
Mr. John Porter

SHIP STRUCTURE SUBCOMMITTEE LIAISON MEMBERS

SOCIETY OF NAVAL ARCHITECTS AND  
MARINE ENGINEERS  
Dr. William Sandberg

NATIONAL ACADEMY OF SCIENCES -  
MARINE BOARD  
Dr. Robert Sielski

CANADA CENTRE FOR MINERALS AND  
ENERGY TECHNOLOGIES  
Dr. William R. Tyson

NATIONAL ACADEMY OF SCIENCES -  
COMMITTEE ON MARINE STRUCTURES  
Dr. John Landes

U. S. NAVAL ACADEMY  
Dr. Ramswar Bhattacharyya

WELDING RESEARCH COUNCIL  
Dr. Martin Prager

U. S. MERCHANT MARINE ACADEMY  
Dr. C. B. Kim

AMERICAN IRON AND STEEL INSTITUTE  
Mr. Alexander D. Wilson

U. S. COAST GUARD ACADEMY  
LCDR Bruce R. Mustain

OFFICE OF NAVAL RESEARCH  
Dr. Yapa D. S. Rajapaske

U. S. TECHNICAL ADVISORY GROUP TO THE  
INTERNATIONAL STANDARDS ORGANIZATION  
CAPT Charles Piersall

MASSACHUSETTS INSTITUTE OF TECHNOLOGY  
CAPT Alan J. Brown

STUDENT MEMBER  
Mr. Jason Miller  
Massachusetts Institute of Technology

*U.S. Coast Guard*

**COMMITTEE ON MARINE STRUCTURES**

**Commission on Engineering and Technical Systems**

**National Academy of Sciences ~ National Research Council**

**The COMMITTEE ON MARINE STRUCTURES has technical cognizance over the interagency Ship Structure Committee's research program.**

**John Landes, University of Tennessee, Knoxville, TN  
Howard M. Bunch, University of Michigan, Ann Arbor, MI  
Bruce G. Collipp, Marine Engineering Consultant, Houston, TX  
Dale G. Karr, University of Michigan, Ann Arbor, MI  
Andrew Kendrick, NKF Services, Montreal, Quebec  
John Niedzwecki, Texas A & M University, College Station, TX  
Barbara A. Shaw, Chairman, Pennsylvania State University, University Park, PA  
Robert Sielski, National Research Council, Washington, DC  
Stephen E. Sharpe, Ship Structure Committee, Washington, DC**

**DESIGN WORK GROUP**

**John Niedzwecki, Chairman, Texas A&M University, College Station, TX  
Bilal Ayyub, University of Maryland, College Park, MD  
Ovide J. Davis, Pascagoula, MS  
Maria Celia Ximenes, Chevron Shipping Co., San Francisco, CA**

**MATERIALS WORK GROUP**

**Barbara A. Shaw, Chairman, Pennsylvania State University, University Park, PA  
David P. Edmonds, Edison Welding Institute, Columbus, OH  
John F. McIntyre, Advanced Polymer Sciences, Avon, OH  
Harold S. Reemsnyder, Bethlehem Steel Corp., Bethlehem, PA  
Bruce R. Somers, Lehigh University, Bethlehem, PA**

*IV spine*

SSC-386 SHIP MAINTENANCE PROJECT Volume 4

Ship Structure Committee 1995

*W. J. Van Ginder*

## RECENT SHIP STRUCTURE COMMITTEE PUBLICATIONS

### Ship Structure Committee Publications – A Special Bibliography

- SSC-384 Post-Yield Strength of Icebreaking Ship Structural Members C. DesRochers, J. Crocker, R. Kumar, D. Brennan, B. Dick, S. Lantos 1995
- SSC-383 Optimum Weld-Metal Strength for High Strength Steel Structures R. Dexter and M. Ferrell 1995
- SSC-382 Reexamination of Design Criteria for Stiffened Plate Panels by D. Ghose and N. Nappi 1995
- SSC-381 Residual Strength of Damaged Marine Structures by C. Wiernicki, D. Ghose, N. Nappi 1995
- SSC-380 Ship Structural Integrity Information System by R. Schulte-Strathaus, B. Bea 1995
- SSC-379 Improved Ship Hull Structural Details Relative to Fatigue by K. Stambaugh, F. Lawrence and S. Dimitriakis 1994
- SSC-378 The Role of Human Error in Design, Construction and Reliability of Marine Structures by R. Bea 1994
- SSC-377 Hull Structural Concepts For Improved Producibility by J. Daidola, J. Parente, and W. Robinson 1994
- SSC-376 Ice Load Impact Study on the NSF R/V Nathaniel B. Palmer by J. St. John and P. Minnick 1995
- SSC-375 Uncertainty in Strength Models for Marine Structures by O. Hughes, E. Nikolaidis, B. Ayyub, G. White, P. Hess 1994
- SSC-374 Effect of High Strength Steels on Strength Considerations of Design and Construction Details of Ships by R. Heyburn and D. Riker 1994
- SSC-373 Loads and Load Combinations by A. Mansour and A. Thayamballi 1994
- SSC-372 Maintenance of Marine Structures: A State of the Art Summary by S. Hutchinson and R. Bea 1993
- SSC-371 Establishment of a Uniform Format for Data Reporting of Structural Material Properties for Reliability Analysis by N. Pussegoda, L. Malik, and A. Dinovitzer 1993
- SSC-370 Underwater Repair Procedures for Ship Hulls (Fatigue and Ductility of Underwater Wet Welds) by K. Grubbs and C. Zanis 1993
- SSC-369 Reduction of S-N Curves for Ship Structural Details by K. Stambaugh, D. Lesson, F. Lawrence, C-Y. Hou, and G. Banas 1993
- SSC-368 Probability Based Ship Design Procedures: A Demonstration by A. Mansour, M. Lin, L. Hovem, A. Thayamballi 1993
- SSC-367 Fatigue Technology Assessment and Strategies for Fatigue Avoidance in Marine Structures by C. C. Capanoglu 1993

Member Agencies:

*American Bureau of Shipping  
Defence Research Establishment Atlantic  
Maritime Administration  
Military Sealift Command  
Naval Sea Systems Command  
Transport Canada  
United States Coast Guard*



**Ship  
Structure  
Committee**

An Interagency Advisory Committee

27 October, 1995

Address Correspondence to:

Executive Director  
Ship Structure Committee  
U.S. Coast Guard (G-MMS/SSC)  
2100 Second Street, S.W.  
Washington, D.C. 20593-0001  
Ph:(202) 267-0003  
Fax:(202) 267-4816

**SSC-386  
SR-1340**

**SHIP MAINTENANCE PROJECT**

This report summarizes the results of a joint industry-government sponsored cooperative research project that focused on the development of engineering technology that could lead to improvements in structural maintenance for new and existing tankers. The project was a milestone in that it was conducted on behalf of 22 sponsoring and participating organizations representing government regulatory bodies, classification societies, new-build and repair yards, and ship owners and operators. In these times of fiscal austerity, future joint industry projects will continue to be essential for leveraging our industry wide research needs.

The report has been divided into four volumes; Fatigue Damage Evaluation, Corrosion Damage Evaluation, Repairs and Maintenance, and Durability Considerations. These studies developed and verified engineering guidelines for the evaluation of fatigue damage and corrosion to critical structural components of existing ships. A Repair Management System is developed to aid in the diagnosis of ship structural failures and the evaluation of repair alternatives. Finally, engineering and maintenance measures to improve the durability of critical structural details in tankers are proposed. A glossary of terms used is provided and recommendations are presented for future research.

A handwritten signature in black ink, appearing to read 'J. C. Card', written in a cursive style.

**J. C. CARD**  
Rear Admiral, U.S. Coast Guard  
Chairman, Ship Structure Committee

1,2X U 3X

**Technical Report Documentation Page**

1. Report No. SSC-386		2. Government Accession No. PB96-113717		3. Recipient's Catalog No.	
4. Title and Subtitle Structural Maintenance Project Volume 4 Design and Maintenance Procedures & Advancements in Tankship Internal Structural Inspections Techniques				5. Report Date September 1992	
				6. Performing Organization Code SMP Vol. 4 (5-1,2)	
				8. Performing Organization Report No. SR1340	
7. Author(s) Ma, Kai-tung, Holzman, R.S., Demsetz, L.				10. Work Unit No. (TRAVIS)	
9. Performing Agency Name and Address University of California at Berkeley Department of Naval Architecture Berkeley, CA 94720				11. Contract or Grant No. 59275-SSC	
				13. Type of Report and Period Covered Final Report	
12. Sponsoring Agency Name and Address Ship Structure Committee U.S. Coast Guard (G-MMS/SSC) 2100 Second St. S.W. Washington D.C. 20593-0001				14. Sponsoring Agency Code G-M	
				15. Supplementary Notes Sponsored by the Ship Structure Committee. Jointly funded by other organizations as a joint industry project. See inside the report for further details.	
16. Abstract  This report is one in a series of reports conducted as part of a two year Joint Industry Research Project "Structural Maintenance for New and Existing Ships" initiated in June 1990 by the Department of Naval Architecture and Offshore Engineering of the University of California at Berkeley to both develop practical tools and procedures for the analysis of proposed ship structural repairs and to prepare guidelines for the cost effective design and construction of lower-maintenance ship structures. This project was organized into six studies. This report is based on the results of Study 5 -- Durability Considerations for New and Existing Ships. Two reports comprise this study. The first study "Design and Maintenance Procedures to Improve the Durability of Critical Internal Structural Details in Oil Tankers" summarizes what was learned in the other studies regarding engineering and maintenance measures to improve the durability of critical internal structural details in oil tankers. The second study "Advancements in Tankship Internal Structural Inspection Techniques" describes methods currently used to gain access to structural members within the tank and discusses the pros and cons of each method. This report also investigates the way in which an inspector records information while in the tank. It also includes a plan for quantitatively comparing these methods. Finally, technologies that may prove useful in the future are discussed.					
17. Key Words Maintenance and Repair Programs Inspection Technique Probability of Detection			18. Distribution Statement Distribution unlimited, available from: National Technical Information Service, Springfield, VA 22161 (703) 487-4650		
19. Security Classif. (of this report) Unclassified		20. SECURITY CLASSIF. (of this page) Unclassified		21. No. of Pages 314	22. Price \$44.50





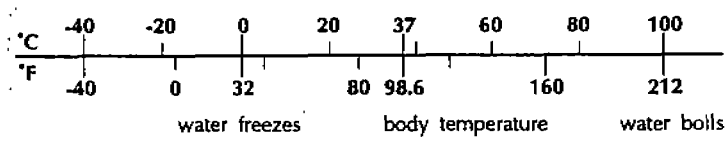
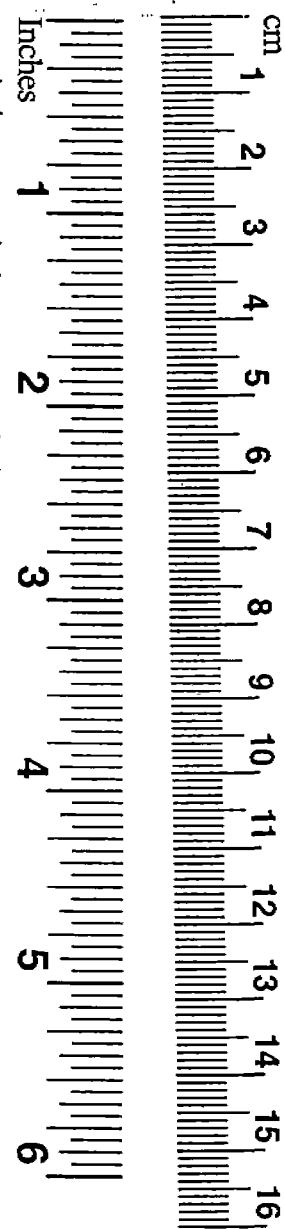
### METRIC CONVERSION CARD

Approximate Conversions to Metric Measures

Symbol	When You Know	Multiply by	To Find	Symbol
<b>LENGTH</b>				
in	inches	2.5	centimeters	cm
ft	feet	30	centimeters	cm
yd	yards	0.9	meters	m
mi	miles	1.6	kilometers	km
<b>AREA</b>				
in <sup>2</sup>	square inches	6.5	square centimeters	cm <sup>2</sup>
ft <sup>2</sup>	square feet	0.09	square meters	m <sup>2</sup>
yd <sup>2</sup>	square yards	0.8	square meters	m <sup>2</sup>
mi <sup>2</sup>	square miles	2.6	square kilometers	km <sup>2</sup>
	acres	0.4	hectares	ha
<b>MASS (weight)</b>				
oz	ounces	28	grams	g
lb	pounds	0.45	kilograms	kg
	short tons (2000 lb)	0.9	metric ton	t
<b>VOLUME</b>				
tsp	teaspoons	5	milliliters	mL
Tbsp	tablespoons	15	milliliters	mL
in <sup>3</sup>	cubic inches	16	milliliters	mL
fl oz	fluid ounces	30	milliliters	mL
c	cups	0.24	liters	L
pt	pints	0.47	liters	L
qt	quarts	0.95	liters	L
gal	gallons	3.8	liters	L
ft <sup>3</sup>	cubic feet	0.03	cubic meters	m <sup>3</sup>
yd <sup>3</sup>	cubic yards	0.76	cubic meters	m <sup>3</sup>
<b>TEMPERATURE (exact)</b>				
°F	degrees Fahrenheit	subtract 32, multiply by 5/9	degrees Celsius	°C

Approximate Conversions from Metric Measures

Symbol	When You Know	Multiply by	To Find	Symbol
<b>LENGTH</b>				
mm	millimeters	0.04	inches	in
cm	centimeters	0.4	inches	in
m	meters	3.3	feet	ft
m	meters	1.1	yards	yd
km	kilometers	0.6	miles	mi
<b>AREA</b>				
cm <sup>2</sup>	square centimeters	0.16	square inches	in <sup>2</sup>
m <sup>2</sup>	square meters	1.2	square yards	yd <sup>2</sup>
km <sup>2</sup>	square kilometers	0.4	square miles	mi <sup>2</sup>
ha	hectares (10,000 m <sup>2</sup> )	2.5	acres	
<b>MASS (weight)</b>				
g	grams	0.035	ounces	oz
kg	kilograms	2.2	pounds	lb
t	metric ton (1,000 kg)	1.1	short tons	
<b>VOLUME</b>				
mL	milliliters	0.03	fluid ounces	fl oz
mL	milliliters	0.06	cubic inches	in <sup>3</sup>
L	liters	2.1	pints	pt
L	liters	1.06	quarts	qt
L	liters	0.26	gallons	gal
m <sup>3</sup>	cubic meters	35	cubic feet	ft <sup>3</sup>
m <sup>3</sup>	cubic meters	1.3	cubic yards	yd <sup>3</sup>
<b>TEMPERATURE (exact)</b>				
°C	degrees Celsius	multiply by 9/5, add 32	degrees Fahrenheit	°F



4  
 13



# Structural Maintenance Project

## Volume 4 : Durability Considerations

### CONTENTS

Cross Reference List

Durability Considerations for New and Existing Ships

Kai-tung Ma  
Robert G. Bea

Advancements in Tankship Internal Structural Inspection Techniques

Robert S. Holzman  
Laura Demsetz

5,6X - E-6X

## Cross Reference List for Reports under the Ship Maintenance Project

University of California, Berkeley Number	Title	SSC Report #	NTIS Accession #
	-SSC Published Reports		
SMP 1-3	Fatigue Reliability of Welded Joints in Tanker Structures	SSC-386-Vol 1	PB96-113683
SMP 1-5	Fatigue Damage Evaluation Software : Theory Documentation	SSC-386-Vol 1	PB96-113683
SMP 1-8	Fatigue Damage Evaluation Software : Verification Analysis	SSC-386-Vol 1	PB96-113683
SMP II-1	The Development of a Rational Basis for Defining Corrosion Limits in Tankers	SSC-386-Vol 2	PB96-113691
SMP 4-1	RMS - Repair Management System	SSC-386-Vol 3	PB96-113709
SMP 5-1	Durability Considerations for New and Existing Ships	SSC-386-Vol 4	PB96-113717
SMP 5-2	Advancements in Tankship Internal Structural Inspection Techniques	SSC-386-Vol 4	PB96-113717
	-The below reports are available from NTIS but were not published by the SSC		
SMP 1-6	Fatigue Damage Evaluations: User Manual	SSC-386-1-6	PB95-261608
SMP 1-7	Fatigue Damage Evaluations: Program Documentation	SSC-386-1-7	PB95-261780
SMP 1-9	Fatigue Damage Evaluations: Structural Maintenance Project Tanker Database	SSC-386-1-9	PB95-261772
SMP 1-10	Fatigue Damage Evaluations: PROSHIP- User Manual	SSC-386-1-10	PB95-261590
SMP 1-11	Fatigue Damage Evaluations: PROSHIP- Program Documentation	SSC-386-1-11	PB95-261582
SMP 2-1	Evaluation of Corrosion Damage in Crude and Product Carriers	SSC-386-2-1	PB95-261798
SMP 2-2	Corrosion Margins for Oil Tankers	SSC-386-2-2	PB95-261806
SMP 2-3	Ship Maintenance Information System	SSC-386-2-3	PB95-264016
SMP 2-4	Corrosion Damage Evaluations	SSC-386-2-4	PB95-264024
SMP 3-1	Structural Analysis and Loadings: Modeling & Analysis Strategy Development	SSC-386-3-1	PB95-264057
SMP 3-1A	Structural Analysis and Loadings: Loadings Strategy Development	SSC-386-3-1A	PB95-264065
SMP 3-2	Study of Critical Structural Details	SSC-386-3-2	PB95-264032

7, 8, 9

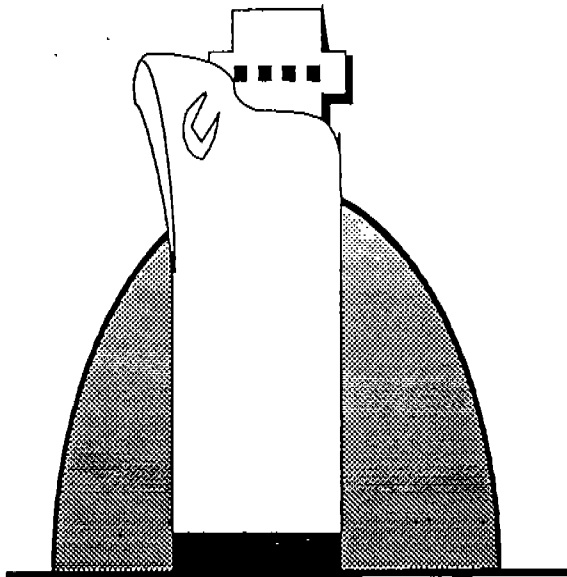
10, 11

# STRUCTURAL MAINTENANCE FOR NEW AND EXISTING SHIPS

---

## Durability Considerations for New & Existing Ships

Design and Maintenance Procedures to  
Improve the Durability of Critical Internal  
Structural Details in Oil Tankers



by  
Kai-tung Ma

Supervised by  
Professor Robert G. Bea

Report No. SMP-5-1  
September, 1992

---

Department of Naval Architecture & Offshore Engineering  
University of California, Berkeley

9,10x (4) 10x

# **Durability Considerations for New & Existing Ships**

**Design and Maintenance Strategies to Improve the Durability of Critical Internal Structural Details in Oil Tankers**

by  
**Kai-tung Ma**

## **Abstract**

With the introduction of very large crude carriers (VLCC) and ultra large crude carriers (ULCC), the tasks of building, maintaining, inspecting and repairing these ships have become increasingly difficult. Many of these ships have experienced varying degrees of internal corrosion and fatigue cracking problems. Number of techniques have been developed to address durability problems in both new and existing crude carriers. However, little work has been done to compile the the techniques and maintenance experience to help designers, ship owners, crew, and naval architects to address these problems. The goal of this report is to provide a comprehensive and practical document on design and maintenance strategies to improve the durability of new and existing ships.

This report includes five topics related to the durability considerations for new and existing ships with emphasis on oil tankers. These topics are: Corrosion Considerations, Fatigue Considerations, Inspections and Monitoring, Maintenance and Information Systems. Corrosion Considerations describes practices that can lead to better corrosion control. Fatigue Considerations introduces the primary aspects of fatigue analysis, materials, fabrication, and design to decrease the incidence of cracking. Inspections and Monitoring summarizes methods currently used to gain access to structural members within the tank and the ways in which an inspector records information while inspecting the tank. Maintenance summarizes the repair methods for corroded steel, fatigue cracks and coating breakdown. Information Systems reviews the development of computer aided systems to help improve maintenance efficiency and effectiveness including corrosion databases, fatigue databases and an inspection and repair data system.

## Table of Contents

	Page
<b>Chapter 1 Introduction.....</b>	<b>1</b>
1.1 Objectives.....	1
1.2 Background.....	1
1.3 Contents of Report.....	2
<b>Chapter 2 Internal Corrosion Considerations.....</b>	<b>5</b>
2.0 Introduction.....	5
2.1 Internal Corrosion in Tankers.....	5
2.1.1 General Corrosion.....	6
2.1.2 Pitting/Grooving Corrosion.....	6
2.2 Structural Configuration for Corrosion Control.....	8
2.2.1 Water Entrapment Prevention.....	8
2.2.2 Shape Considerations for Improving the Adhesion of Coating.....	8
2.2.3 Minimizing the Trend of Structural Flexure.....	10
2.3 Coating System Choices.....	10
2.3.1 The Composition of a Coating System.....	10
2.3.2 Four Paints Widely Used in Tanks.....	11
2.3.3 Recommended Coating System Choices.....	12
2.4 Application Procedures.....	13
2.4.1 Condition of Steel Work Before Gritblasting.....	13
2.4.2 Surface Preparation.....	14
2.4.3 Temperature, Humidity Control, and Ventilation.....	16
2.4.4 Quality Control.....	16
2.5 Sacrificial Anode.....	17
2.5.1 Materials of Sacrificial Anodes.....	17
2.5.2 Calculation of Anode Weights.....	18
2.5.3 Installation of Anodes.....	19
2.5.4 The Drawbacks of Anodes.....	20
<b>Chapter 3 Fatigue Considerations.....</b>	<b>22</b>
3.0 Introduction.....	22
3.1 Fatigue Failures in Ship Structures.....	23
3.1.1 Crack Locations.....	23
3.2. Cyclic Loads.....	28

3.2.1 Four Sources of Cyclic Loads.....	28
3.3 Fatigue Analysis .....	30
3.3.1 Fatigue Analysis Procedures.....	30
3.3.2 Sea States (Wave Spectra).....	33
3.3.3 Ship Motion Analysis.....	34
3.3.4. Stress Range Transfer Function.....	35
3.3.5 Finite Element Analysis .....	36
3.3.6. Short-term & Long-term Probability Density Function.....	37
3.3.7 S-N Curves.....	37
3.3.8 Damage Accumulation .....	40
3.3.9 Damage Acceptability .....	41
3.4 Simplified Fatigue Analysis.....	43
3.4.1 Simplified Fatigue Analysis .....	44
3.4.2 Long-term Distribution of Stress Range .....	44
3.5 Factors Influencing Fatigue Life.....	46
3.5.1 Geometry of Member or Detail (Stress Concentration).....	46
3.5.2 Material.....	49
3.5.3 Construction Flaws.....	50
3.6 Improved CSD Design.....	51
3.6.1 Countermeasures Against Fatigue Failure.....	51
3.6.2 Examples of Improved Detail Design .....	52
<b>Chapter 4 Inspection and Monitoring.....</b>	<b>57</b>
4.0 Introduction .....	57
4.0.1 Objectives of Inspection .....	57
4.0.2 Objectives of Monitoring .....	58
4.1 Construction Inspections.....	58
4.1.1 Structure .....	58
4.1.2 Coatings .....	62
4.2 In-service Inspections .....	63
4.2.1 Planning and Preparation.....	63
4.2.2 Execution of Survey.....	68
4.2.3 Data Analysis .....	78
4.3 Design Considerations for Accessibility & Ventilation .....	81
4.3.1 Accessibility.....	81
4.3.2 Ventilation .....	84
4.4 Structural Monitoring .....	84

4.4.1 Applications .....	85
4.4.2 Systems .....	86
<b>Chapter 5 Maintenance and Repair .....</b>	<b>89</b>
5.0 Introduction .....	89
5.0.1 Objectives of Maintenance and Repairs .....	89
5.0.2 Maintenance and Repair Programs .....	89
5.1 Steel Repairs .....	91
5.1.1 Steel Renewal .....	91
5.1.2 Steel Reinforcement .....	93
5.1.3 Crack Repair .....	93
5.2 Maintenance of Corrosion Control Systems .....	98
5.2.1 General Corrosion .....	98
5.2.2 Pitting and Grooving .....	100
5.2.3 Sacrificial Anodes .....	103
<b>Chapter 6 Information Systems .....</b>	<b>107</b>
6.0 Introduction .....	107
6.1 Objectives of Information Systems .....	107
6.2 Components of Information Systems .....	109
6.3 Current Information System Developments .....	112
6.3.1 Corrosion Databases .....	112
6.3.2 Fatigue Cracking Databases .....	113
6.3.3 Repair Databases .....	117
6.3.4 Critical Area Inspection Plan (CAIP) .....	117
6.3.5 CATSIR System .....	118
6.4 Summary .....	124

## List of Figures

	Page
Figure 2.1: Pitting .....	7
Figure 2.2: Grooving.....	7
Figure 2.3: Water entrapment prevention .....	8
Figure 2.4: Different drainage shapes (The sharp corners in the left are hard to do surface preparation and is easy to hold dirt in.) .....	9
Figure 2.5: Coating thickness influenced by surface tension on sharp edges .....	9
Figure 2.6: Some edges that need grinding.....	9
Figure 2.7: Surface preparation of weld .....	14
Figure 2.8: Common areas of coating missing.....	17
Figure 2.9: An anode installed near the bottom plates of cargo tanks.....	19
Figure 3.1: An typical example of a fatigue crack in a side shell longitudinal.....	23
Figure 3.2: Comparison of stress in side shell with that in bottom .....	24
Figure 3.3: Failure percentage of 12 detail families .....	26
Figure 3.4: Fatigue analysis procedure .....	32
Figure 3.5: Stress range transfer function .....	36
Figure 3.6: A ship structural detail and the corresponding class F fatigue specimen.....	37
Figure 3.7: S-N curves .....	38
Figure 3.8: The relations between CSD and different class S-N curves.....	39
Figure 3.9: S-N curves with different reliability .....	39
Figure 3.10: The Miner summation procedure for one particular stress block.....	41
Figure 3.11: Probability density function of U .....	42
Figure 3.12: $U_D$ as a function of the design reliability for $B=2$ and $\sigma_F=1$ (realistic values).....	43
Figure 3.13: Optimum for fatigue design.....	43
Figure 3.14: Long-term distribution of stress range of large tankers, bulk carriers and dry cargo vessels compared with Weibull.....	45
Figure 3.15: The definitions of SCF [3.13].....	47
Figure 3.16: An example of mill tolerance [3.13].....	50
Figure 3.17: Decreasing discontinuity and using soft toe for a beam bracket.....	52
Figure 3.18: Adding a backing bracket for a tripping bracket .....	53



Figure 3.19: Using soft collar-ring plate and expanding it to reduce discontinuity for a slot .....	53
Figure 3.20: Using soft scallop (middle picture) and adding brackets (right picture) for a flat-bar stiffener.....	54
Figure 4.1: Common areas of coating missing.....	62
Figure 4.2: Climbing without fall safety device [4.2] .....	71
Figure 4.3: Physical climbing with fall safety device [4.2] .....	71
Figure 4.4: Fixed Staging [4.2] .....	73
Figure 4.5: Rafting [4.2] .....	73
Figure 4.6: Portable staging [4.2] .....	75
Figure 4.7: Mechanical arm [4.2] .....	75
Figure 4.8: An example showing the arrangement of access facility in a wing tank [4.10].....	82
Figure 4.9: A spacious double bottom tank will be easy to inspect [4.10].....	83
Figure 4.10: The left picture shows an access opening which is large enough to walk through easily; the right one shows the opening is too small to go through easily [4.10].....	83
Figure 4.11: An example of installation of ship response monitor [4.15].....	87
Figure 5.1: Repair alternatives example [5.2] .....	95
Figure 5.2: Repair example at the connection of longitudinals to transverse webs [5.4].....	96
Figure 5.3: Repair example at the connection of longitudinals to plane transverse bulkheads [5.4] .....	97
Figure 5.4: Assessment scale for breakdown [5.3].....	101
Figure 5.5: Application of pourable filler in pittings.....	102
Figure 5.6: Application of coating in pittings.....	102
Figure 5.7: Spigot plate.....	103
Figure 6.1: Basic parts of information system for inspection, maintenance, & repair .....	108
Figure 6.2: CATSIR drawing showing gauging data [6.5].....	120
Figure 6.3: CATSIR drawing showing steel renewal areas [6.5].....	121
Figure 6.4: Principal components of an advanced information system [6.1] .....	124

18 (15)

## List of Tables

	Page
Table 2.1: The areas where corrosion occurs frequently .....	7
Table 2.2: Recommendation on coating system choices .....	13
Table 2.3: Summary of surface preparation specifications.....	15
Table 2.4: Current densities of anodes for different areas [2.10].....	18
Table 3.1: Summary of failure data for 12 detail families [3.4] .....	25
Table 3.2: Detail classifications [3.3] .....	27
Table 3.3: Wave scatter diagram (based on the Walden wave data).....	33
Table 3.4: The data of S-N relations.....	38
Table 3.5: Examples of SCF in different types of intersection [3.13].....	48
Table 4.1: Summary of non-destructive testing methods [4.1].....	61
Table 4.2: Inspection program [4.3] .....	65
Table 4.3: Minimum requirements of thickness measurements at special hull surveys of oil tankers [4.3].....	66
Table 4.4: Minimum requirements of tank testing at special hull surveys of oil tankers [4.3].....	66
Table 4.5: Summary of access methods [4.2] .....	76
Table 4.6: Criteria of wastage for local strength of structural components [4.3] .....	80
Table 6.1: Summary of vessel tabular and graphical database components [6.1].....	111
Table 6.2: Code for locations of longitudinal members [6.7].....	115
Table 6.3: Code for locations of transverse members [6.7].....	116
Table 6.4: Summary of CATSIR database components .....	122

## PREFACE

The two year Joint Industry Research Project "Structural Maintenance for New and Existing Ships" was initiated in 1990 by the Department of Naval Architecture and Offshore Engineering, University of California at Berkeley. The objective of this project was to develop practical tools and procedures for the analysis of proposed ship structural repairs and to prepare guidelines for the cost-effective design and construction of lower-maintenance ship structures.

This project was made possible by the following sponsoring organizations:

- *American Bureau of Shipping*
- *Amoco Ocean Tanker Company*
- *Arco Marine Incorporated*
- *BP Marine*
- *Bureau Veritas*
- *Chevron Shipping Company*
- *Daewoo Shipbuilding & Heavy Machinery Ltd.*
- *Exxon Company International*
- *Ishikawajima-Harima Heavy Industries Ltd.*
- *Jurong Shipyard Ltd.*
- *Lisnave - Estaleiros Navais De Lisboa, S. A.*
- *Maritime Administration*
- *Military Sealift Command*
- *Mitsubishi Heavy Industries Inc.*
- *Mobil Ship and Transportaion Company*
- *National Defense Headquarters (Canada)*
- *Naval Sea Systems Command*
- *Newport News Shipbuilding & Dry Dock Co.*
- *United States Coast Guard*

In addition, the following organizations contributed to the project as observers:

- *Germanischer Lloyd*
- *Lloyd's Register of Shipping*
- *West State Inc.*

This project was organized into six studies:

- Study 1 -- Fatigue Damage Evaluations**
- Study 2 -- Corrosion Damage Evaluations**
- Study 3 -- Interaction of Details with Adjacent Structure**
- Study 4 -- Fatigue and Corrosion Repair Assessments**
- Study 5 -- Durability Considerations for New & Existing Ships**
- Study 6 -- Development of Software and Applications Examples**

This report is based on the results of Study 5 -- Durability Guidelines for New & Existing Ships. The objective of this study is to summarize what has been learned in the other studies of this project regarding engineering and maintenance measures to improve the durability of critical internal structural details in oil tankers:

# Chapter 1 Introduction

## 1.1 Objectives

With the introduction of very large crude carriers (VLCC) and ultra large crude carriers (ULCC), the tasks of building, maintaining, inspecting and repairing them have become increasingly difficult. Most of these vessels experienced varying degrees of internal corrosion and fatigue cracking problems. These tankers have been in service for many years. Their experience can provide useful information to designers or ship owners. Though a number of techniques have been developed, little work has been done on compiling the information of the techniques to help designers, ship owners, crew or naval architects to control these problems. The goal of this report is to provide a comprehensive and practical document on design and maintenance strategies to improve the durability of new and existing ships.

## 1.2 Background

This report is the final product of one study in the joint industry research project "Structural Maintenance for New and Existing Ships". To assist with this study, a committee was formed. The committee consisted of eleven experienced engineers from the following organizations:

- American Bureau of Shipping (Y. K. Chen, John Colon, and Jack Spencer)
- Amoco Ocean Tanker Company (Tom Hagner, and Frank Tiedemann)
- BP Marine (Dave Witmer)
- Chevron Shipping Company (Rong Huang, and Mark Buetzow)
- Mobil Ship and Transport Company (Jasbir Jaspal)
- Newport News Shipbuilding & Dry Dock Co. (Mark Debbink)
- United States Coast Guard (Mike Parmelee, and Keith Dabney)

Four committee meetings were held at the University of California Berkeley during this study. The committee members supplied important insights and information to the study. Technical data on new and existing tankers and maintenance experiences were provided by committee members.

The author wishes to express his appreciation to those individuals who have made significant contributions to this report. A special thank to Rong Huang of Chevron for his technical advice, many parts of this report were completed under his direction. Also, thanks to my adviser, Professor R. G. Bea, for getting me started and helping me through the project.

### **1.3 Contents of Report**

This report includes five topics related to the durability considerations for new and existing ships with more emphasis on oil tankers. These are:

- Internal Corrosion Considerations
- Fatigue Considerations
- Inspections and Monitoring
- Maintenance and Repair
- Information Systems

Chapter 2, Internal Corrosion Considerations, summarizes strategies for corrosion control. Four strategies are described. They are arranging structural configurations, choosing adequate coating systems, controlling application procedures and applying sacrificial anodes.

Chapter 3, Fatigue Considerations, introduces considerations to reduce fatigue crackings including procedures for fatigue analyses.

Chapter 4, Inspections and Monitoring, summarizes methods currently used to inspect structural members within tanks and the ways in which an inspector records information while inspecting in the tank. Additionally, the basics of a structural monitoring system are introduced.

**Chapter 5, Maintenance and Repair, introduces repair methods for corroded steel, fatigue cracks, and different types of corrosion and coating breakdown.**

**Chapter 6, Information System, reviews the development of computer aided systems to improve the efficiency and effectiveness of maintenance operations including corrosion databases, fatigue databases, and an inspection and repair management system.**

25, 26x  26x

# Chapter 2 Internal Corrosion Considerations

## 2.0 Introduction

Internal corrosion in tankers provides the single largest maintenance problem for crude oil tankers. Though a number of techniques have been developed, little work has been done on compiling the techniques to help design for better corrosion control. This chapter summarizes guidelines for the corrosion control of internal tanks of oil tankers. An introduction of internal corrosion in tankers is done in the next section. After that, four strategies against corrosion are described. There include:

- 1) Arrange structural configuration,
- 2) Choose adequate coating systems,
- 3) Control application procedures, and
- 4) Use sacrificial anodes.

## 2.1 Internal Corrosion in Tankers

Internal corrosion in a crude oil tanker has different forms and different effects depending on the types of tanks. Generally, there are only four types of tanks in the next generation tankers. They are segregated ballast tanks (water ballast tanks), cargo tanks, cargo/heavy ballast tanks (cargo tank carrying water ballast only in heavy weather), slop tanks (tank carrying oil-water mixture). Except these four, cargo/ballast tank is another type of tanks in the past generation tankers. Anyway, cargo/ballast tanks have been prohibited for all tankers over 70,000 DWT, because of environmental considerations.

Of these four, corrosion in water ballast tanks and slop tanks is deemed the worst. For the longitudinal bulkhead details of these tanks, corrosion rates may range from 0.04

to 1.20 mm/yr [Reference 2.8]. Even coated ballast tanks experienced coating breakdowns and pitting/grooving corrosion ranged from 1.0 to 3.0 mm/yr after a certain number of service years [2.2]. These lead to a lot of steel plate replacements. On the other hand, cargo tanks as well as cargo/heavy-ballast tanks have little general corrosion because crude oil works like a coating. However pitting occurs in the bottom plates of cargo tanks. That is caused by a layer of water which stays between cargo oil and bottom plates. The water settles out from cargo or comes from the residual of tank cleaning. The areas where corrosion occurs most frequently and their major causes are listed in Table 2.1.

### 2.1.1 General Corrosion

General corrosion occurs homogeneously over the surface of the internal plating by means of a chemical or electrochemical reaction. It can be easily found in an old uncoated ballast tank. Prevention of this type of corrosion can be achieved by applying a suitable protective coating. Also sacrificial anodes can serve as a backup if the coating breaks down.

### 2.1.2 Pitting/Grooving Corrosion

Pitting (Figure 2.1) is a form of localized attack in which small areas of steel plate surfaces are corroded with penetration into the steel at these areas. For a tanker, it usually occurs in the horizontal surfaces of the cargo tanks. Grooving (Figure 2.2) is another form of localized corrosion in which relatively long and narrow areas of steel are corroded at a higher rate than the surrounding areas, giving the appearance of long grooves in the steel. In coated ballast tanks, grooving can be found especially at the intersections of longitudinal stiffeners with a longitudinal bulkhead or a side shell. Prevention lies in applying a suitable protective coating, applying sacrificial anodes, or a design that prevents stagnation of water.



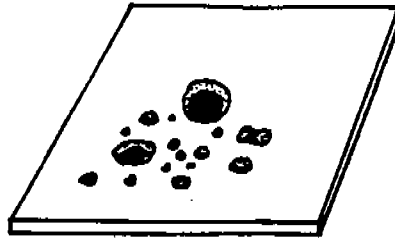


Figure 2.1: Pitting

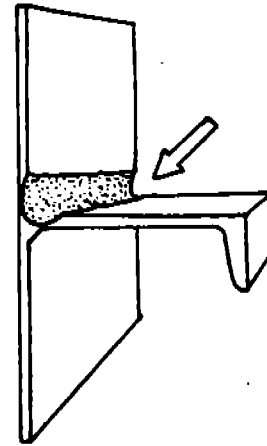


Figure 2.2: Grooving

These corrosions lead to the reduction in the thickness of steel to be less than the allowable limits as defined by a Classification Society or an owner/operator. In this case, steel must be replaced and/or reinforced. Steel replacement and reinforcement are both expensive and time consuming, so all practical efforts to control corrosion should be made. For the rest of this chapter, four strategies of corrosion control during the design and construction stage are presented.

Table 2.1: The areas where corrosion occurs frequently

Areas where corrosion starts	Major Causes
Top areas of ballast tanks	The splash of free surface during partially full ballast condition not only causes abrasion but also provides a better condition for corrosion.
Bottom plates of cargo tanks	The layer of sea water below cargo oil causes corrosion.
Heated zone by heat coil	Temperature difference between heated cargo and cold ballast water accelerates coating breakdown and corrosion.
Horizontal surfaces	Sea water entrapped there causes corrosion.
High stress areas	Deflection of steel surface causes coating breakdown.
Welds	Pinholes, sharp projection on welds may penetrate coating.
Sharp edges	Coating is thinner there because of surface tension (Figure 2.5).

## 2.2 Structural Configuration for Corrosion Control

Structural configuration greatly influences the chance of corrosion. The more complex the geometry of a structure is, the higher the probability of corrosion is. Thus, some paint manufacturers recommend to use a better coating system in those tanks with many complex structural details like ladders and stairs. In this section, three structural configurations that can somewhat reduce the chances of corrosion are introduced.

### 2.2.1 Water Entrapment Prevention

Structural details on tanks which can collect sea water may increase the chances of corrosion. Typical examples are shown in Figure 2.3, where open shapes of a side longitudinal can collect water. Two methods which can be used to prevent water entrapment are water shedding design and drainage arrangement. Nevertheless, experiences show that drainage hole may cause another corrosion problem around its edges. As a result, water shedding design is always considered first.

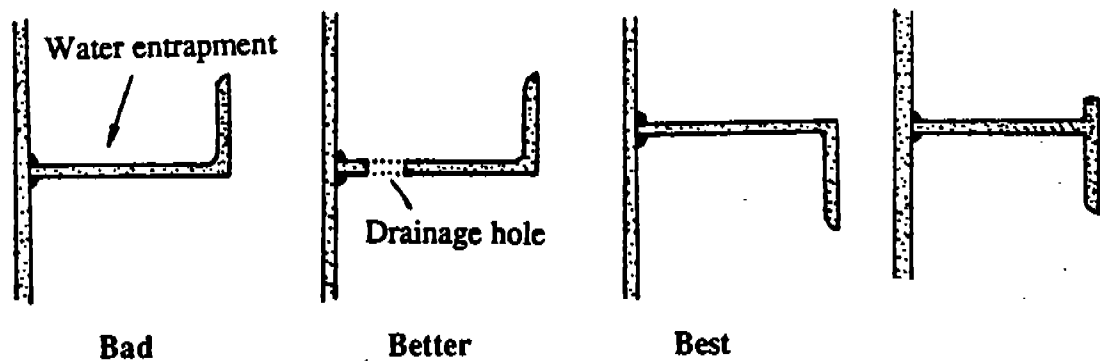


Figure 2.3: Water entrapment prevention

### 2.2.2 Shape Considerations for Improving the Adhesion of Coating

Lack of coverage on sharp edges (Figure 2.4) has been identified as one of the major causes of coating breakdown. Because of the surface tension, a coating that wraps sharp edges is usually thinner than one on flat plates (Figure 2.5). It is hard to apply the coating of a sufficient thickness on those places. Rounded sections are easier to coat and

are less prone to damage than the edges of rectangular sections. Nevertheless, the use of rounded contours is not always practicable. If round shapes are not possible, grinding (Figure 2.6), stripe coating, and high viscosity quick setting coatings can be used to improve the adhesion of coatings on sharp edges.

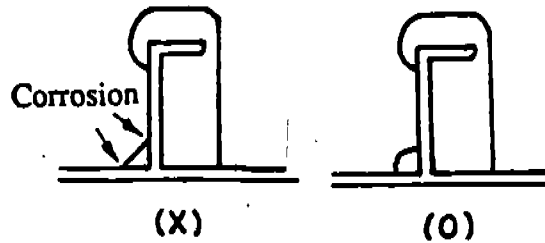


Figure 2.4: Different drainage shapes (The sharp corners in the left are hard to do surface preparation and is easy to hold dirt in.)

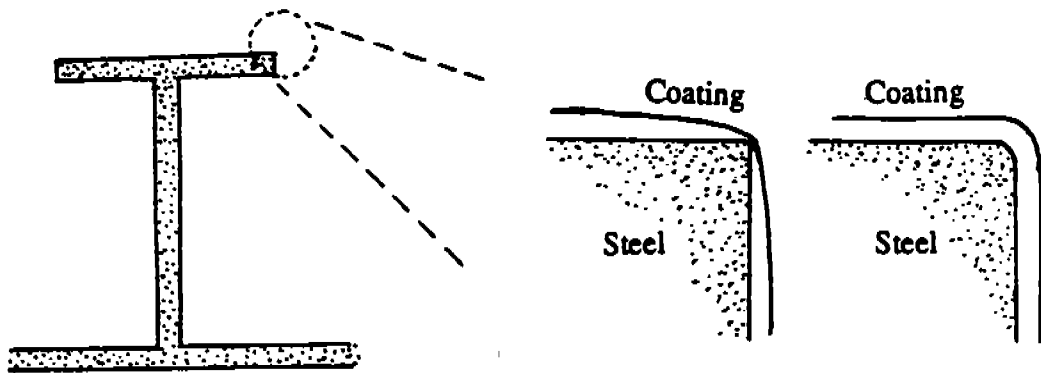


Figure 2.5: Coating thickness influenced by surface tension on sharp edges

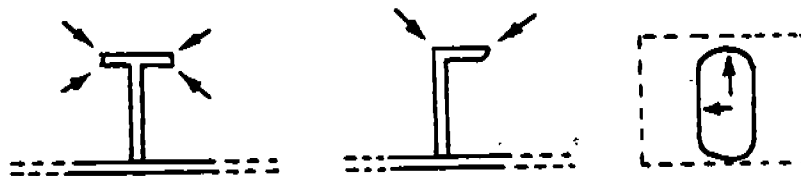


Figure 2.6: Some edges that need grinding

### **2.2.3 Minimizing the Trend of Structural Flexure**

Coating can be broken down by the deflection of steel and also high stress which caused by the deflection can accelerate corrosion on unprotected surfaces. High stress areas experience a relatively high degree of corrosion. Thus, it is better to minimize high flexure structural components.

## **2.3 Coating System Choices**

There are many different coating systems to choose from. For those surfaces subjected to a mild corrosion environment, a simpler coating system may be applied. On the other hand, those surfaces subjected to a severe corrosion environment will require a high quality coating system. In this section, a general introduction about coatings is presented. Also, a recommendation on coating system choices is presented.

For inspection convenience, it is better to use a lighter color on the outside layer of the coatings. It is easier to inspect cracks or coating defects (rust streaks and areas of coating breakdown) on lighter color coatings since most tanks are completely dark. Lighting requirements during tanks in operations are also reduced.

### **2.3.1 The Composition of a Coating System**

The paints used most widely in marine conditions are "two-pack" epoxy coatings. Two-pack means that these paints are prepared by mixing two components just before application. These two components are epoxy resin and a 'hardener' or 'curing agent' containing amino groupings. There are various curing agents which modify the application and drying characteristics of the coatings, so different kinds of coatings are available. These two components are mixed just before use and after application the paint cures to a hard durable coating. Mixing of the components in the correct proportions, which vary with different products, is essential. Paints of this type harden or cure by chemical reaction within the material itself. This has led coatings to provide thick protective films that cure comparatively quickly. As the process of drying is basically a chemical reaction, it is temperature and time dependent. This means that once a coating material is mixed, it must be applied within limited time. Furthermore, at low

temperatures drying times may be prolonged, so they should not be applied below the manufacturer's recommended temperatures.

These paints generally contain solvents and can be applied by airless spray. There are, however, also solvent-free coatings, mainly epoxies, that are used for some application. Generally, solvent-free coatings can be applied to high film thickness, e.g. 300-1000 microns.

Depending on the number of layers and the thickness of each layer, there are one-coat system, two-coat system, three-coat system, and other multi-coat system. It is advisable to apply at least two coats of paint to reduce the influence of any defects such as pinholes in the film and holiday areas. A coating system, say a two-coat system, can consist of primer, first coat, and second coat. It is common practice to use different colors for each layer of coating to distinguish them and to specify the thickness of each coat. Ship yards like to use only a one coat system so called 'Ship Yard Friendly System', since class societies require all tanks of new tankers to be painted.

### 2.3.2 Four Paints Widely Used in Tanks

**1. Epoxy:** Epoxies are durable, hard and have good adhesion properties when applied to clean steel. Because of their hardness, particularly as this increases with aging, adhesion problems may arise when maintenance painting. The important aspects of epoxies are the 'pot-life', i.e., the maximum period between mixing and application and the curing temperature. The curing temperature and the speed of reaction at different temperatures are important. Some epoxies cannot be cured at low temperatures, say below about 5 C, and others may react too quickly at tropical temperatures. Clearly, the paint manufacturer's advice should be sought to ensure that the correct material is used for a specific purpose.

**2. Coal Tar Epoxy:** Coal tar epoxies, epoxies added with coal tar, provide a cheaper product than the epoxies and have better water resistance. Coal tar epoxy coatings are black or sometimes a dark red. Also, they can be bleached. They are particularly suitable for protection of steel immersed in sea water.

**3. Urethane:** Polyurethane has similar properties to epoxies. They provide hard, tough, abrasion-resisting coatings which by changes in formulation can produce a range

of finished surface from high gloss to semi-matt, with a wide choice of colors. A high standard of steel surface preparation is required for urethanes.

**4. Coal Tar Urethane:** Coal tar urethanes are used for the same purposes as coal tar epoxies. They are broadly similar. Coal tar urethanes are reported to have improved flexibility and impact resistance compared with coal tar epoxies.

### 2.3.3 Recommended Coating System Choices

The cost of blasting and coating during the construction of new tankers is approximately 50% to 80% of the cost of blasting and coating for an existing ship. This is because both blasting and coating are more quickly and easily performed on new steel than old. Also, most shipyards perform much of the coating work while the structure is still in the pre-assembly module stage of construction. This results in easier access and better environmental conditions. Thus, it is generally proved to be economical to choose a better coating system during new construction to elongate the life of the first coating.

Cargo tanks have a very low corrosion rate from 0.03 to 0.06 mm/year except some bottom and deck areas. Bottom and deck components often have a corrosion rate more than 0.10 mm/year. A lot of pitting and grooving has occurred in bottom plates in the past. It is economical to use less coating on most areas; and apply better coating in the other areas as follows:

- 1) Deck head and down to deck transverse depth
- 2) Upper surface longitudinal center girders
- 3) Bottom plating and bottom structures
- 4) Upper surface of horizontal girder of transverse and swash bulkhead.

Another choice is that applying no coating at all in cargo tanks. Since the maximum corrosion rate in cargo tanks is 0.10 mm/yr, the wastage of steel will be only about 2 mm after the service period of 20 years. It is about 10% to 20% of the thickness of steel. That is still under the allowable limit regulated by classification societies.

Table 2.2: Recommendation on coating system choices

Tank types	Coating System Choices	Thickness (Microns)	Average Life* (Years)
Ballast tanks & Slop tanks	a). 2 Coat Coal Tar Epoxy	250-450	8-10
	b). 3 Coat Coal Tar Epoxy	300-500	10-14
Cargo tank	a). 2 Coat Epoxy	250-450	8-10
	b). 2 Coat Epoxy (Partially coated)	250-450	--
	c). No Coat	0	--

\*Data of average life from reference [2.7]

## 2.4 Application Procedures

Once the coating system has been chosen, it is imperative that it is applied properly to achieve its best performance. A report indicated that after reviewing the repair histories of many ships, some ships were found to experience coating failures after service, while the others with the same coating configuration remained maintenance free even after ten years. Since the relations between causes and effects do not depend directly on the type of coating and its thickness, this may suggest that some other factors such as surface preparation are important. Listed below are the procedures that will determine the effectiveness of coatings.

### **2.4.1 Condition of Steel Work Before Gritblasting**

In most cases, the first area of a painted tank to show paint breakdown is at the welds or sharp edges. During construction a weld may be sound in strength but may be considered unsatisfactory as a surface to apply paint on. The welds have pinholes, sharp projections, and undercutting which may not only protrude through the paint films but also detach from the surface. Therefore, before welds are painted, all weld spatter should be removed and welds should be ground and then blast-cleaned. (See Figure 2.8) Holes must be filled either by rewelding or with an appropriate epoxy filler. Also it is recommended to add an extra stripe coat of a primer to the weld area. In addition, all sharp edges are recommended to be ground off to approximately 3.0 milli-meters radius as minimum prior to gritblasting (See Figure 2.5 and 2.6). In summary, the following tasks should be done before gritblasting [2.11]:

- All sharp edges and welds to be ground,
- All welding spatter and slag to be removed,
- All plate laminations are to be removed,
- All oil residue is to be removed.

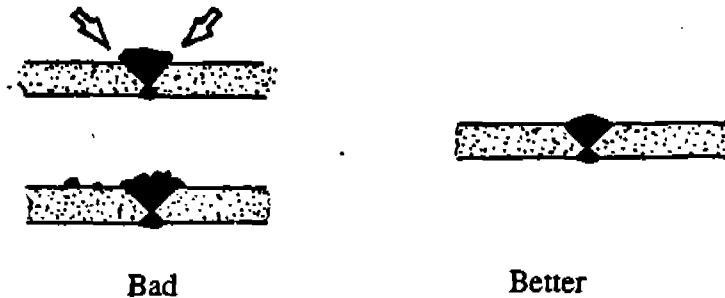


Figure 2.7: Surface preparation of weld

### 2.4.2 Surface Preparation

The first and the most important step in assuring good application is surface preparation. This effort is to improve the adhesion of a coating. If there is oil or grease contamination, this must first be removed by solvent or vapor, for example, chlorinated hydrocarbon, alkali, or emulsion cleaning. The degreased surface can then be grit blasted. Some paint systems definitely require a clean surface, but all paint systems benefit from it. Many paint systems are tolerant of adherent films of various kinds; however, all paint systems require that loose millscale and rust are removed. If adherent, millscale is painted over, this is an invitation to later disaster. Millscale is cathodic to steel and can stimulate rapid corrosion reactions at imperfections as the paint wears off or deteriorates.

Manufacturers of some brands of paints were claimed that they can be applied to rusted steel. In fact, all paints will give best performance on steel if they have been cleaned adequately. Paints with an inhibitive primer, such as the red lead pigmented types, will be somewhat more tolerant of rust than other types of paint. Still, painting on rust is never recommended.



The measurement of surface profile produced by blast-cleaning is important, because the profile influenced the effective thickness of paint that covers and protects the steel. If the profile is too high, paint may be penetrated by some high peak of the profile. On the other hand, if the profile is too low, the blasting will not improve the attachment of paint much. There may be a preferred profile height for different coatings. An easy rule is that the profile should not be more than about one-third of the total thickness of the paint system [2.3]. So for a total film thickness of 210 microns, the maximum profile after blast-cleaning would be about 70 microns.

**Table 2.3: Summary of surface preparation specifications**

SSPC specification	Description
SP1: Solvent cleaning	Removal of oil, grease, dirt, soil, salts, and contaminants by cleaning with solvent, vapor, alkali, emulsion, or steam
SP2: Hand tool cleaning	Removal of loose rust, mill scale, and paint to degree specified by hand chipping, scraping, sanding, and wire brushing
SP3: Power tool cleaning	Removal of loose rust, mill scale, and paint to degree specified, by power tool chipping, descaling, sanding, wire brushing, and grinding
SP5: White metal blast cleaning	Removal of all visible rust, mill scale, paint, and foreign matter by blast cleaning by wheel or nozzle (dry or wet), using sand, grit, or shot (for very corrosive atmospheres where high cost of cleaning is warranted)
SP6: Commercial blast cleaning	Blast cleaning until at least two-thirds of the surface area is free of all visible residues (for rather severe conditions of exposure)
SP7: Brush-off blast cleaning	Blast cleaning of all except tightly adhering residues of mill scale, rust, and coatings, exposing numerous evenly distributed flecks of underlying metal
SP8: Pickling	Complete removal of rust and mill scale by acid pickling, duplex pickling, or electrolytic pickling
SP10: Near white blast cleaning	Blast cleaning nearly to white-metal cleanliness, until at least 95% of the surface area is free of all visible residues (for high-humidity, chemical atmosphere, marine, or other corrosive environments)

Definitions by the Steel Structure Painting Council

### 2.4.3 Temperature, Humidity Control, and Ventilation

Temperature and relative humidity of the air influence solvent evaporation, drying time and viscosity. The relative humidity indicates the amount of moisture in the air. Moisture influences painting operations in a number of ways. It may, at high relative humidity, lead to moisture left on the surface to be painted and it may affect the curing of paints. The relative humidity requirements for particular types of coatings should be given in coating specifications and must be adhered to. The coating done with bad temperature and humidity control still looks nice initially. However, it will break down sooner than expected. Another factor should be kept an eye on is ventilation. Ventilation must be kept on until the solvent is gone. This takes several days. If ventilation is bad or ventilation equipment is removed before the coatings has released all their solvent, the coating will blister and fail earlier.

In summary, the tank must be kept in a condensation free condition. The recommended steel temperature is above 10° C and at least 3° C above the dew point of the air in the tank. At all times the relative humidity must be kept below 80% and adequate ventilation must be supplied for the removal of solvents from the coatings and the tank [2.11]. All ventilation ducting must be arranged to give maximum efficiency. Rain shelters must be erected in way of tank coatings and tank cleaning apertures to prevent ingress of rain, dust and other contaminants.

### 2.4.4 Quality Control

Once the coating has been completed, it is almost impossible for ship owners to examine the quality of the coating. Therefore, quality control during coating procedures is critical. Quality control on corrosion prevention can be done by the supervision of ship owners, paint manufacturers and the workmanship of ship yards. The supervision of ship owners influences dramatically the quality of new ships. Generally some supervisors will be sent by ship owners to the ship yard to supervise the construction of their new ships during the whole period. These supervisors should have been well trained and have sufficient experience to make sure that all the work has been done well step by step. On the other hand, ship yards have the responsibility to assure the quality of their products. The workmanship of different ship yards differs from each other.

The causes of coating failures that construction and repair supervisors and inspectors should pay special attention to are listed below:

- (a) Inadequate surface preparation,
- (b) Inadequate storage after blast-cleaning that causes corrosion again,
- (c) Inadequate working temperature or humidity,
- (d) Incorrect drying periods between applications of successive coatings,
- (e) Coating omission on the corners of structural details(See Figure 2.9),
- (f) Poor application procedures, and
- (g) Insufficient film thickness.

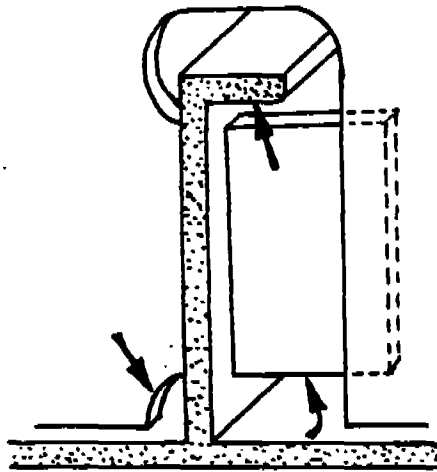


Figure 2.8: Common areas of coating missing

## 2.5 Sacrificial Anode

### 2.5.1 Materials of Sacrificial Anodes

A sacrificial anode is a piece of less noble metal, for example zinc, aluminum, and magnesium, which galvanically corrode and so protect the steel from corrosion. While falling and striking bottom plating, magnesium anodes and aluminum anodes may provide sparks to cause explosion in cargo tanks [2.7]. As a result, the use of magnesium in cargo tanks has been prohibited. Also aluminum anodes that are used in cargo tanks are restricted used under the height which will not make their potential energy exceed 200 ft-lb. However, aluminum does possess two advantageous properties. One is its self-cleaning ability. After being immersed in crude oil for days, aluminum anodes are

quick to stabilize current, an important quality for cargo/ballast tanks. Another advantage is its density. Considerably fewer amounts of aluminum anodes are required to provide the same protective current as the same size zinc anodes. Both in cargo tanks and ballast tanks, zinc is widely used as the material of anodes, because of no restrictions on its use or installation.

### 2.5.2 Calculation of Anode Weights

Anode weights can be calculated as follows:

$$\text{Anode weight (Kgs)} = \frac{\text{Total area (m}^2\text{)} * \text{Current density (mA/m}^2\text{)} * \text{Ballasted period (Hrs/yr)} * \text{Required life (Years)}}{\text{Current capacity (A*h/kg)}}$$

In the formula, the values of current densities for different areas are listed in Table 2.4. Required life is usually designed for 3-5 years, although it can be designed as long as ten years if desired. The most significant factor influencing the life of zinc anodes is the amount of time that the tank is in ballast. Since anodes are only active during ballast cycles. Most ships spend an average of 30% to 50% of their time in a ballast condition. Current capacities are depended on the material of anodes. When the anode has reached about 85% consumption, it should be replaced.

**Table 2.4: Current densities of anodes for different areas [2.10]**

Surface	Current (mA/sq.m)	Density (mA/sq.ft)
Cargo/Clean Ballast Tanks	86	8
Upper Wing Tanks	120	11
Fore & Aft Peak Tanks	108	10
Lower Wing Tanks	86	8
Double Bottom Tank, Ballast Only	86	8
Coated Surfaces	5	0.5

### 2.5.3 Installation of Anodes

According to past investigation [6], the use of zinc anodes acting to supplement coating is often more economical than coatings alone in ballast tanks. They act to extend the useful life of the tank coating. Ballast tanks are required to be painted by class societies. Thus, sacrificial anodes are used as backup there. Cargo tanks always contain a layer of water from one inch to several inches in depth left in the bottom. Anodes (see Figure 2.10) are installed low on the webs of bottom longitudinals to protect bottom plates from pitting corrosion.

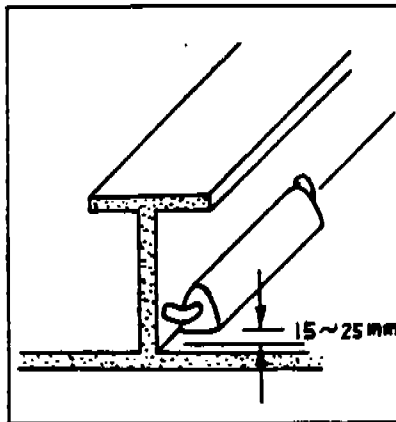


Figure 2.9: An anode installed near the bottom plates of cargo tanks

There are three methods of attaching the anodes to the steel inside a tank that are acceptable to classification societies.

1. Welding directly to the tank structure
2. Clamping directly to the tank structure
3. Bolting to pads welded directly to the tank structure

Welding is the cheapest method to use on new construction. This method provides the most secure attachment with the least chance of a loss of contact. Clamping is the cheapest method of initially attaching anodes on existing ships. Bolted anodes take longer to install initially. However, their replacement is easily accomplished without hot work.

Homogenous distribution of zinc anodes greatly influences the effectiveness of their performance. Therefore the locations of anodes in tanks should be designed properly.

#### 2.5.4 The Drawbacks of Anodes

There are two drawbacks to using sacrificial anodes. First, sacrificial anodes are restricted to environments of suitable conductivity. Only steel immersed in sea water is protected. Second, the effectiveness of anodes is limited if the anodes are covered with debris and sediment.

References:

- [2.1] Robert G. Bea, "Marine Structural Integrity Programs", Ship Structure Committee Report No. SSC-365, 1991
- [2.2] Tanker Structure Cooperative Forum, "Condition Evaluation and Maintenance of Tanker Structures", TSCF Work Group report, 1991
- [2.3] Kenneth A Chandler, "Marine and Offshore Corrosion", 1985
- [2.4] V.R. Pludek, "Design and Corrosion Control", 1977
- [2.5] J. T. N. Atkinson and H. VanDroffelaar, "Corrosion and Its Control. An Introduction to the Subject", 1982
- [2.6] Philip A. Schweitzer, P.E., "Corrosion and Corrosion Protection Handbook", 1988
- [2.7] Herring, Jr., LC, Titcomb, AN, Newport News Shipbuilding, "Investigation of Internal Corrosion and Corrosion-Control Alternatives in Commercial Tankships", Ship Structure Committee Report No. SSC-312, 1981
- [2.8] Rob Roy Pollard, "Evaluation of Corrosion Damage in Crude and Product Carriers", Project Report No. SMP-2-1, Structural Maintenance for New and Existing Ships, Dept. of Naval Arch. & Offshore Eng., Univ. of California, Berkeley 1991
- [2.9] Francis L. Laque, Scripps Institution of Oceanography, "Marine Corrosion. Causes and Prevention", University of California, San Diego.
- [2.10] Chevron Shipping Company, "Chevron Shipping Company Standards for Sacrificial Anodes", 1990
- [2.11] Rodney Towers, Sigma Coatings Marine Division, "Advanced epoxy coating systems for ballast and cargo tanks", Fifth Project Meeting, Structural Maintenance for New and Existing Ships, Univ. of California, Berkeley, January, 1992

# Chapter 3 Fatigue Considerations

## 3.0 Introduction

In the present generation of crude oil carriers, fatigue related cracks in critical structural details (CSD) constitute one of the single largest maintenance problems associated with the structure of these ships. The fundamental roots of this problem are centered in inadequate design of the CSD for cyclic loads.

Fatigue cracking is the result of excessively high cyclic stresses in CSD. There are two basic ways to reduce these stresses: (1) reduce the magnitudes and numbers of high cyclic loads, and (2) reduce the magnitudes of the high cyclic stresses. In general, not too much can be done to significantly reduce the sources of high cyclic loads. Slowing the ship down and choosing headings in severe seas to minimize pounding and slamming, routing to avoid storms, configuration of the hull to minimize the frequency and volume of green water on the deck, and changes in the trade routes of the ship to less severe weather areas are examples of cyclic load management strategies.

The second way to reduce fatigue cracking is to reduce the stress levels. This can be accomplished by a variety of structural strategies such as increasing the scantlings of the steel sections, providing gradual changes in stiffness of intersections, providing balanced stiffness and strength in connections to eliminate "secondary stresses," improving weld profiles (to provide gradual changes in stiffness), and reducing fabrication misalignments (that result in high secondary stresses).

Fatigue analyses are intended to provide the marine engineer with the necessary information to reduce the chances of experiencing unexpected fatigue cracking and provide an acceptable degree of "durability" in the CSD. A fatigue analysis should not be expected to result in a perfectly crack free ship. The uncertainties and variability associated with fatigue analyses and the economics associated with cyclic stress reductions will not allow a perfectly crack free ship to be practically realized. Sufficient durability and the lack of unpleasant surprises in the form of excessively cracked CSD



that will pose unexpected future maintenance problems are the principal objectives of a fatigue analysis.

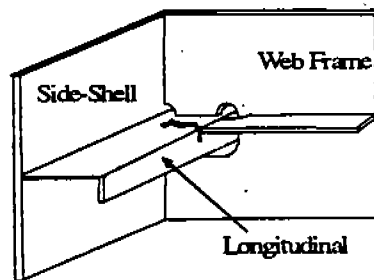
In this chapter, the location and the causes of fatigue cracking of CSD in the present generation of tankers are summarized. The sources and characteristics of cyclic loads that lead to fatigue cracking are summarized. Then, basic concepts of a spectral fatigue analysis and a simplified fatigue analysis are introduced. Finally, the countermeasures to minimize fatigue cracking are discussed and the improved designs of several types of CSD are illustrated.

### **3.1 Fatigue Failures in Ship Structures**

When steel is subjected to cyclic stresses, if the stress ranges (maximum to minimum stress) and the numbers of cycles are large, then the steel can fail by progressive cracking. Present experience indicates about 70% of the total damage in ships over 200 m in length may be classified as fatigue damage [3.8].

#### **3.1.1 Crack Locations**

Based on the database created by Ship Structural Maintenance project (SMP), it was found that 42% of cracks in 10 VLCCs were located in the connection between side shell longitudinals and transverse frames [3.2]. A typical example of crack locations is shown in Fig 3.1.



**Figure 3.1: An typical example of a fatigue crack in a side shell longitudinal**

Many of the fatigue cracks of side longitudinals occur in the region between fully loaded water line and ballast water line. This region corresponds to the area with highest dynamic loads. The magnitude of fluctuating stresses in side shell compared with those

45

in bottom (Fig. 3.2) shows that the cyclic stress range in side shell is significantly higher than that in bottom. In the bottom or deck the fluctuating stresses are mainly axial stresses caused by hull girder bending. In the side shell the dominating fluctuating stresses are caused by local bending of the longitudinals, fluctuating hydrostatic and hydrodynamic pressures (due to roll and heave motion of the vessel and waves). Combined roll and local wave pressures create fluctuating stresses in side shell longitudinals in the region between full load and ballast water lines which are considerably greater than fluctuating stresses in bottom or deck longitudinals.

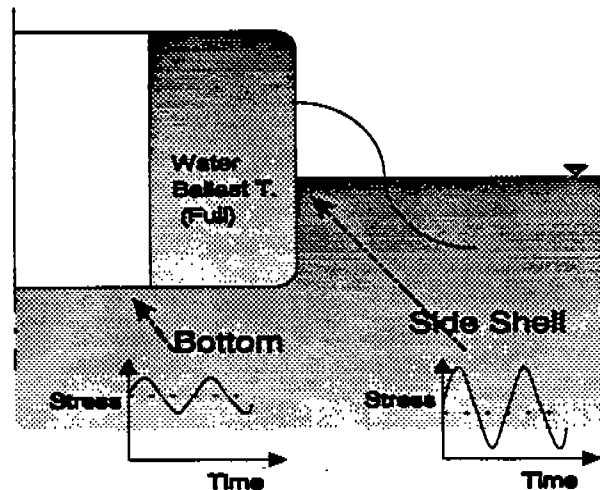


Figure 3.2: Comparison of stress in side shell with that in bottom

The cracks normally start at welded connections between side shell longitudinals and supporting stiffeners or brackets. Cracks most frequently initiate in the weld heat affected zone, however cracks can initiate from defects in fabricated sections (e.g., high stress concentrations caused by hand flame cut longitudinals or stiffeners), poorly welded sections (incomplete weld penetration), and poorly aligned sections. The most frequent damage of side shell longitudinals has been found at their connection to transverse bulkheads where relative transverse deflection between the bulkhead and adjacent web frames generates additional bending stresses.

In general, the majority of these cracks are mostly found in the following types of locations [3.1]:

- Intersections of longitudinals and stiffeners (particularly side shell longitudinals) with transverse bulkheads, or transverse web frames,

- Bracketed end connections of primary and secondary supporting elements,
- Discontinuities in high stressed face plates, stiffeners, and longitudinal members,
- Openings and cut-outs in primary structures, and
- Bad weld profiles and poorly cut plates.

Past studies [3.3] [3.4] have been conducted to provide data on the performance of structural details, and to identify what types of details crack most frequently. In these studies, structural detail failure data were collected and classified into 12 detail families to provide guidance in the selection of structural detail configurations (Table 3.1 & 3.2). The results of the survey show that 2252 of the total 6856 damaged locations, or 32.8%, were found in beam bracket connections. Tripping brackets have the second highest failure percentage, 23.1% (Figure 3.3).

The results of these studies show a good correlation with the results of the survey reported in a Swedish study [3.9]. In the Swedish study 1135 of 2227 cracks, or 51.0%, were located in bracket connections. It also showed that oil tankers contained a disproportional number of the damaged areas, many more than the other three ship types.

**Table 3.1: Summary of failure data for 12 detail families [3.4]**

No.	Detail Family Name	Totals Observed		
		Total No. of Details	Total No. of Failures	% Failures
1	Beam Bracket	68586	2252	3.28
2	Tripping Brackets	34012	1587	4.67
3	Non-Tight Collars	20974	33	0.16
4	Tight Collar	20654	46	0.22
5	Gunwale Connection	172	5	2.91
6	Knife Edge Crossing	0	0	-
7	Miscellaneous Cutouts	296689	853	0.29
8	Clearance Cutouts	57307	843	1.47
9	Structural Deck Cuts	7534	29	0.38
10	Stanchion Ends	7090	122	1.72
11	Stiffener Ends	40729	298	0.73
12	Panel Stiffeners	53837	788	1.46
Totals		607584	6856	1.13

Failure Numbers by Detail Families

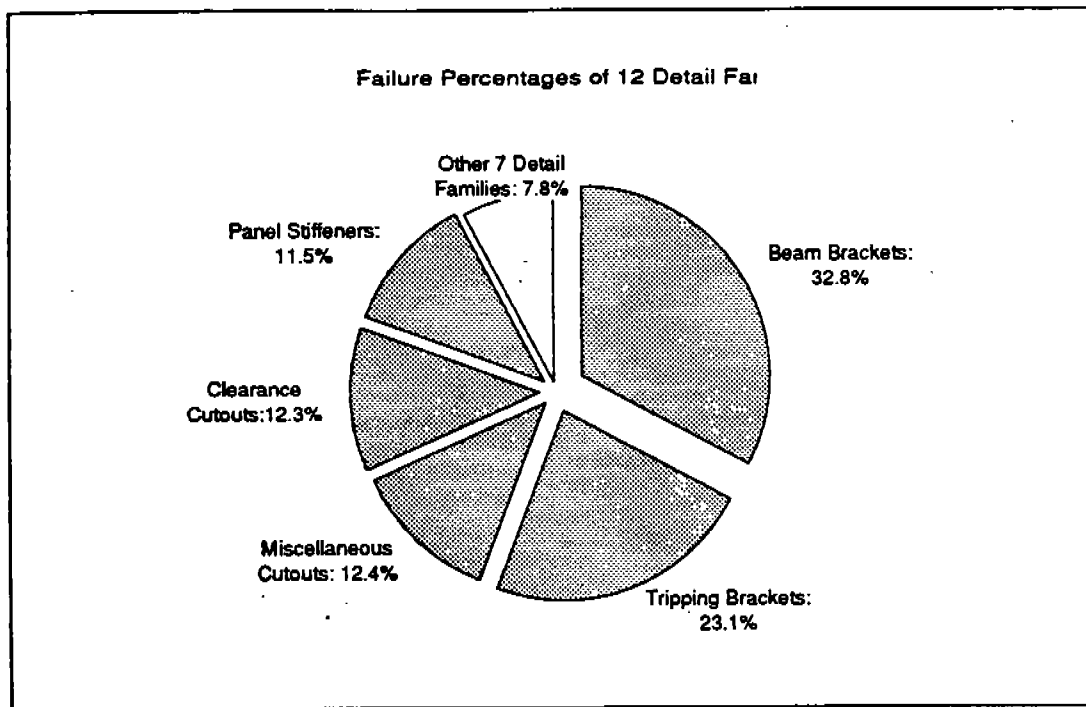
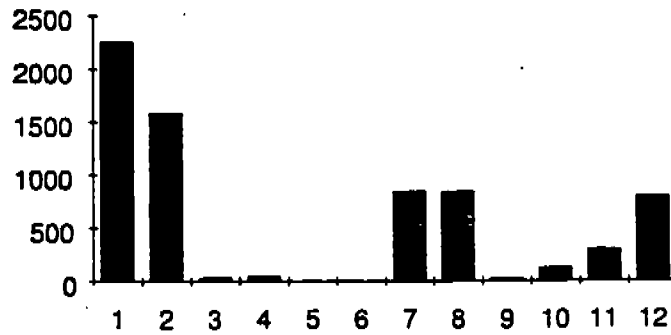
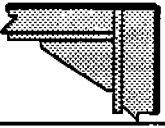
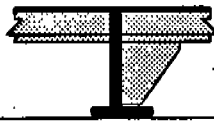
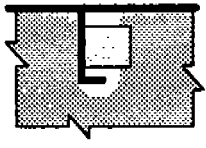
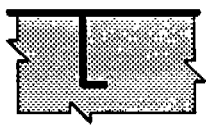

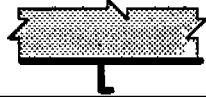
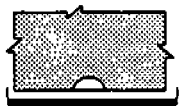
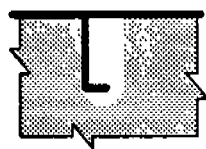


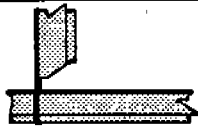



Figure 3.3: Failure percentage of 12 detail families

48

**Table 3.2: Detail classifications [3.3]**

Type #	Name	Functional Provision	Typical Configuration
1	Beam Bracket	Increase strength of framing and stiffening members at their supports.	
2	Tripping Brackets	Laterally support framing and stiffening members.	
3	Non-Tight Collars	Provide a connection from webs of framing and stiffening members to the plating of supports that have cutouts at the members.	
4	Tight Collar	Same as 3 above except also cover the cutouts to prevent passage of fluid or objects through the cutout.	
5	Gunwale Connection	Join the strength deck stringer plate to the sheer strake.	
6	Knife Edge Crossing	Permits complimentary stiffening systems on opposite sides of plate	
7	Miscellaneous Cutouts	Provide a wide variety of holes for access, drainage, ease of fabrication, cable ways, pipes, stress relief, etc.	
8	Clearance Cutouts	Provide a hole in an intersecting member to allow another member to go through.	
9	Structural Deck Cuts	Allow passage through decks for access, tank cleaning, piping, cables, etc.	
10	Stanchion Ends	Transfer loads between stanchions and deck supporting members.	
11	Stiffener Ends	Connect an un-bracketed non-continuing stiffener to a supporting member.	
12	Panel Stiffeners	Stiffen plating and webs of girders. These are non-load carrying members.	

## 3.2. Cyclic Loads

The first step in a fatigue analysis is to identify and characterize the cyclic loading imposed on or induced in the ship structure. The sources and characteristics of cyclic loads are usually the 'big unknown' when it comes to diagnosing causes of fatigue failures or in performing a fatigue analysis for design of a new CSD. Important factors which influence cyclic loads are trade routes, amount and type of heavy weather encountered, number of loaded/ballasted cycles, how the master handles the vessel in heavy weather, docking and lightering history and procedures, and even how often heating coils are used.

### 3.2.1 Four Sources of Cyclic Loads

The types of loading which are of primary concern in fatigue are those which are cyclic. Further, in general the cyclic loads of primary concern are those that occur very frequently and over long periods of time. This is the regime of high-cycle, low stress fatigue. Loads such as those experienced in launching the ship, in ship collisions and grounding are not generally considered in a fatigue analysis; they are of concern in the basic design of the ship for strength and stability.

Low frequency fatigue relates to long-term reversals extending from those stress changes that take place with temperature changes, ship loading and unloading, cargo-ballast movements, and waves. High frequency fatigue relates to those stress reversals that are associated with dynamic loads such as those from bow flare or wave slamming, whipping, and springing. Four main sources of cyclic loads are tabulated below along with the estimated cycles of load reversals in a typical ship's lifetime [3.5].

Loading Category	Cycles
(1) Low frequency, wave-induced (quasi-static)	$10^7 - 10^8$
(2) High frequency (dynamic)	$10^6$
(3) Still water	340
(4) Thermal	7000

**(1) Low Frequency Wave-induced Loading:** Some of the factors known to affect the wave loading are the type of ship, its loading condition, still water bending moment, draft, trim, speed, heading, and sea condition. Among these factors, measurements and analyses indicate that the sea conditions and characteristics have the greatest influence on wave-induced cyclic loading history [3.18].

**(2) High Frequency Loading:** High frequency loads are considered to be caused by two primary sources: (1) slamming and whipping, (2) excitation by machinery or propellers. In many cases, high frequency loads from these sources are of little significance because they cause small stress fluctuations. However, in some cases they can result in high local cyclic stresses such as blow flare or wave slamming loads concentrated in the fore-peak area of ships trading on severe weather routes, or machinery and propeller induced cyclic loads in the stern area of the ship for poorly balanced or isolated machinery and propellers.

**(3) Still Water Loading:** Still water loading represents the mean load during a period of a voyage as fuel is consumed and as ballast is added or shifted. Also, there are large variations in still water loading from voyage to voyage. Oil tankers especially encounter extremely different loading conditions between fully loaded voyages and ballasted voyages.

**(4) Thermal Loading:** Thermal stresses are induced by the presence of an irregular thermal gradient and can be considered as a type of loading. The thermal gradient in a ship depends on the weather, sea-air temperature differential and exposure to the sun. Consequently, the thermal-load variation generally follows the diurnal changes in air temperature. The intermittent use of heating coils is another source of thermal load fluctuations.

The construction of a complete ship loading history requires consideration of stresses due to still water, thermal and dynamic effects in addition to low frequency wave-induced stresses. However, the still water and thermal stresses are very low frequency, and their effect is primarily to shift the mean stress. These stresses will have relatively little effect on the lifetime load history. High frequency loads due slamming and whipping are still not well understood. In the present development of fatigue analyses, the cyclic stress ranges caused by wave-induced loads and ship motions (and sometime loading-unloading) are considered.

### **3.3 Fatigue Analysis**

In the past, tanker CSDs have generally been designed without an explicit fatigue analysis. CSDs have been designed so that they only had sufficient basic strength or capacity. Until recently, this approach had generally proved to develop CSD that had both sufficient strength and durability. Severe cracking or durability problems began to become obvious, since the advent of highly optimized hull structure designs, the use of higher strength steels, and much larger ships.

There are many different types of fatigue analyses, ranging from very complex "spectral fatigue stress analysis" (SFSA) methods that attempt to determine the effects of the entire life time of cyclic stress ranges to much simpler "allowable fatigue stress analysis" (AFSA) methods that limit the maximum local stress range in a given CSD. The cores of these methods are linear transfer function processes. These processes use a simple proportional relationship between a particular input variable (e.g., wave spectrum), and a particular output variable (e.g. stress at given point in a given CSD). Because of linearity, superposition (addition) can be used to define the resultant of different processes. Nonlinear processes can not be easily incorporated into this framework; equivalent linearizations must be employed.

Experience with a wide variety of fatigue sensitive structures (e.g., offshore platforms, airframes) indicates that the simplified "AFSA" method should be a derivative of the more complex "SFSA" methods. At the present stage of development of explicit fatigue analyses for the present generation of tankers, we are still building experience with the SFSA. The state of knowledge and practice is being developed so that AFSA can be implemented into practice. In the remainder of this section, the basic concepts of a SFSA will be discussed. The basic concepts of AFSA will be introduced in the next section.

#### **3.3.1 Fatigue Analysis Procedures**

At the beginning of fatigue analysis, one must define the service profile for the ship which includes loading conditions, routes of vessel operation, speeds and sea headings, and time at sea and port. For a tanker, at least one representative full load and



one representative ballast condition should be considered. For speeds, it is typical to use 75% of the design speed in those conditions. Eight wave headings are in general considered: head seas, bow quartering (port and starboard), beam seas, stern quartering (port and starboard), and following seas, and the various vessel headings are often assumed equi-probable. Credit in any analysis may be taken for time spent in port. For tankers, the sea time can be as much as 80% of the total.

There are thousands of CSD in a ship. It is not feasible to perform fatigue analyses for each of them. Generally, fatigue analysis is performed on representative details from CSD groups with similar configurations and similar loading conditions. Fatigue analyses should be performed on groups of CSD that may have high consequences associated with cracking and high likelihoods of cracking. The consequence rating for the CSD will be dependent on the location and function of the CSD and the associated structural system. The locations of high likelihood of cracking can be determined on the basis of experience (e.g., locations and CSD that have a history of frequent cracking) and stress analysis (indicating locations that may experience large numbers of cycles of high stress ranges).

According to statistical data from ship structural surveys [3.3][3.4], beam brackets and tripping brackets experience highest and second highest numbers of cracks. Thus they should be investigated first. Also, recent studies indicate that side shell longitudinals which bear slamming of sea surface and cyclic loads of sea wave experience most fatigue cracks [3.2][3.13]. Consequently the fatigue analysis should first be focused on the intersection between the side shell longitudinals and transverse bulkhead or web (Figure 3.1). More specifically, welds between bracket toes/heels and side shell longitudinals are most critical.

A fatigue analysis proceeds through five basic steps:

1. Identify and characterize the sources of cyclic stresses for the projected life.
2. Determine the stress ranges and numbers of cycles at the "hot spots" of a CSD.
3. Characterize the S-N relation of the CSD.
4. Determine the anticipated likelihood of cracking for the proposed CSD.
5. Determine if the damage is acceptable or not. If not, revise CSD or hull structure framing to lower stress ranges and repeat #1-#5 until an acceptable damage is achieved.

These steps are organized in Figure 3.4 (the numbers in the lower left corner of each of the boxes are keyed to the sections in this Chapter).

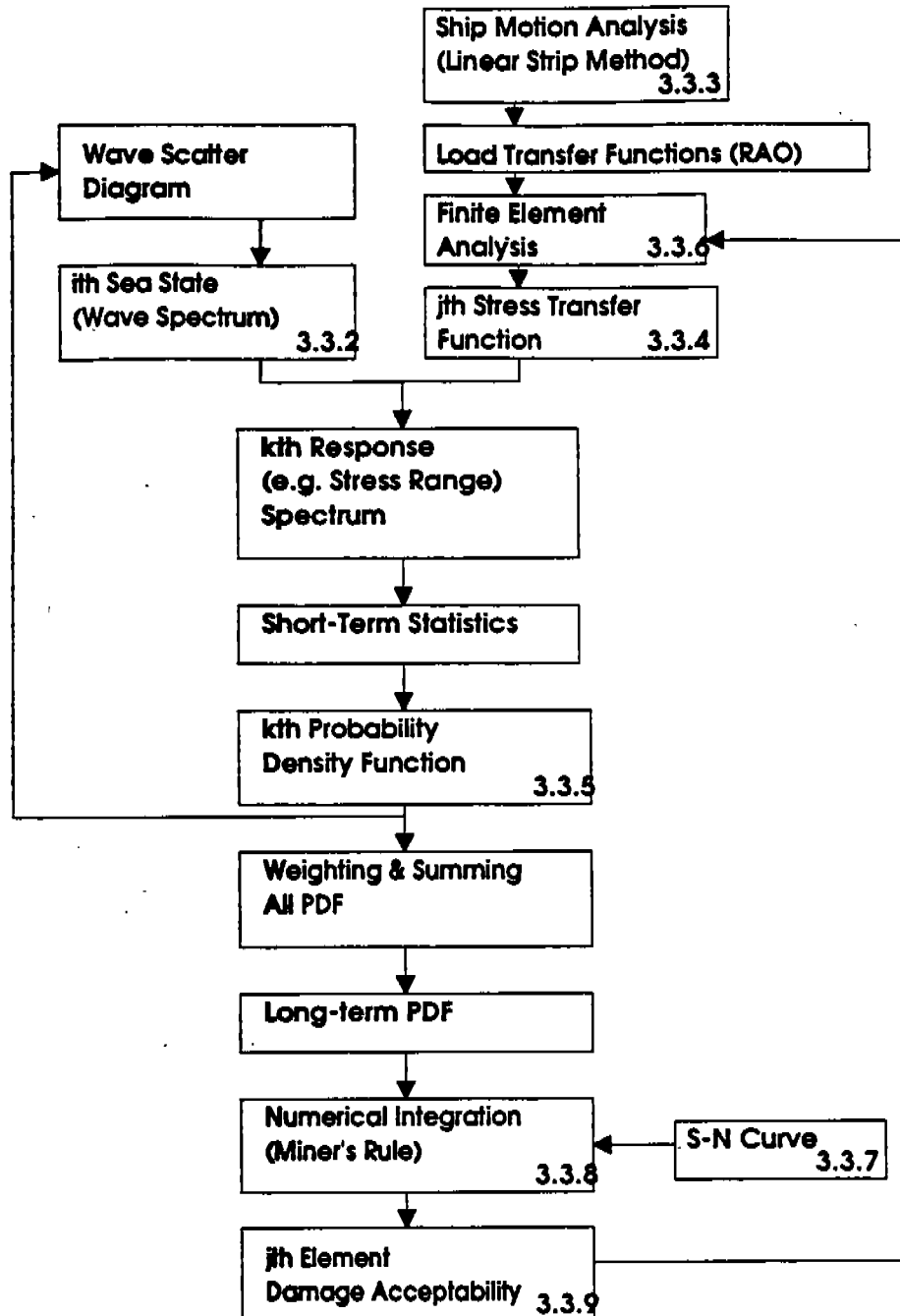


Figure 3.4: Fatigue analysis procedure

### 3.3.2 Sea States (Wave Spectra)

The description of the long term wave environment for any vessel route is made through a wave scatter diagram, which contains information on the wave heights, periods, and associated occurrence times for the sea states. Any cell in the scatter diagram is characterized by two parameters: a significant wave height and a zero crossing period. These heights and periods of any cell in the scatter diagram are used to generate individual wave spectra that provide energy descriptions for the sea state. These spectra define the wave amplitudes and frequencies for the sea state. The superposition of the amplitudes and frequencies define the wave heights and periods that can be encountered in that sea state.

In design stage, use of the Walden data (Table 3.3) is common. Such data derive from visual observations by trained observers. Other sets of data like the British Maritime Technology enhanced observed wave data [3.19], and also measured and hindcast data are also available.

**Table 3.3: Wave scatter diagram (based on the Walden wave data)**

Hs(m)	Zero Crossing Period (secs)									Total
	3	5	7	9	11	13	15	17	19	
1		0.23656	0.06765	0.01950	0.00286	0.00039	0.00011	0.00137		0.32844
2		0.14765	0.11831	0.03024	0.00368	0.00047	0.00009	0.00056		0.30100
3		0.05288	0.09269	0.03299	0.00546	0.00068	0.00012	0.00027		0.18509
4		0.01672	0.04436	0.02228	0.00479	0.00114	0.00008	0.00029		0.08966
5		0.00446	0.01730	0.01289	0.00313	0.00056	0.00013	0.00004		0.03851
6		0.00297	0.00990	0.00886	0.00303	0.00059	0.00008	0.00003		0.02546
7		0.00142	0.00447	0.00522	0.00193	0.00038	0.00004	0.00004		0.01350
8		0.00109	0.00255	0.00392	0.00198	0.00050	0.00003	0.00002		0.01009
9		0.00054	0.00136	0.00226	0.00154	0.00068	0.00020	0.00004		0.00662
10		0.00002	0.00010	0.00011	0.00010	0.00005	0.00002			0.00040
11			0.00003	0.00008	0.00017	0.00006				0.00034
12		0.00005		0.00014	0.00022	0.00006	0.00001			0.00048
13		0.00002		0.00007	0.00009	0.00003		0.00001		0.00022
14				0.00002	0.00006	0.00002		0.00001		0.00011
15		0.00002		0.00001	0.00001	0.00002	0.00001	0.00001		0.00008
16										0
Total	0	0.46440	0.35872	0.13859	0.02905	0.00563	0.00092	0.00269	0	1

### 3.3.3 Ship Motion Analysis

The wave induced loads can be organized as:

- Global forces (bending moments, shears, and torsional moments),
- Local external hydrodynamic forces (pressures), and
- Local internal inertia forces from cargo and ballast.

For fatigue analysis purposes, the load calculation is accomplished using generally accepted linear ship motion theory for regular waves (linear waves of unit height and specified frequency) [3.20]. The ship hull is divided into a number of prismatic strips for which the hydrodynamic properties are calculated under the assumption of two-dimensional flow. The vertical fluid forces on the strips are subdivided into five categories:

1. A wave pressure force component, the Froude-Krylov pressure calculated from wave potential without influence from the ship hull;
2. A wave pressure force component computed from the properties of the diffracted wave system when the ship is maintained as fixed;
3. A hydrostatic restoring force that is proportional to the instantaneous water plane area of the ship from its mean position;
4. An inertia force due to acceleration of the fluid (added mass force).
5. A damping force arising from wave radiation from the ship; and

The first two of the force components define the total wave induced exciting force computed as though the ship moves forward through the waves without oscillatory motions. The last three force components are determined as if the ship were moving forward through calm water. The fourth force component is that due to the ship's body forces, i.e., mass of the ship that is contained in the strip times the acceleration experienced by the strip. Each of the hydrodynamic pressure components varies harmonically with the wave period, but with different phases.

A linear strip theory based ship motion computer program is used to generate the transfer functions for the vessel motion in six degrees of freedom, accelerations, hydrodynamic pressure around the surface of the vessel, and vertical bending, lateral

bending, and torsional moments and shear forces along the vessel length [3.20, 3.21]. Several ship motion computer programs are available. Recently, these programs have begun to more precisely address the complex hydrodynamics of the free-surface region [3.21].

The offsets of the vessel and the weight distributions are the primary input variables. Eight wave headings are in general considered: head seas, bow quartering (port and starboard), beam seas, stern quartering (port and starboard), and following seas. Multiple speeds can also be considered. As results, the motion, acceleration, shear force, bending moment and hydrodynamic pressure transfer functions are obtained as a function of frequency, heading, and speed.

Such a process ignores several potentially important sources of hydrodynamic cyclic loads. Blow flare and bottom slamming are ignored as are green water on the deck effects (bow plunging). Due to the use of small amplitude wave theory, loads developed on surfaces within the wave zone are only treated in an approximate way. Wave skewness (crest amplitude greater than trough amplitude) effects are also be approximated. Special "ad hoc" adjustments must be made to the hydrodynamic pressures computed in the wave zone to develop reasonable linear hydrodynamic pressure transfer function characterizations for the structure elements in this zone [3.22].

#### **3.3.4. Stress Range Transfer Function**

A stress range transfer function represents the cyclic stress response of unit height waves of varying frequencies. The stress range transfer functions are usually obtained by using quasi-static finite element analysis. The use of static analysis assumes that structural dynamics, transient loads, and effects such as springing are insignificant.

One potential difficulty in obtaining the stress range transfer functions is the number of finite element analysis (FEA) cases needed. If two loading conditions (full load and ballast) and eight headings are considered, then 16 transfer functions need to be determined. To get the curve of each one of them, the values of the transfer functions at several frequencies should be calculated. However, experience indicates that particular calculations for at least three well-chosen frequencies and using the transfer function of the predominant load as a guide are typically adequate [3.16]. One of the chosen frequencies should correspond to the peak of the predominant loading. If phase

information is to be preserved, there are two separate calculations for any one frequency, corresponding to the real and imaginary parts of the load transfer function.

After all the transfer functions are assembled they can be multiplied by the sea amplitude spectrum to get the response stress range spectrum.

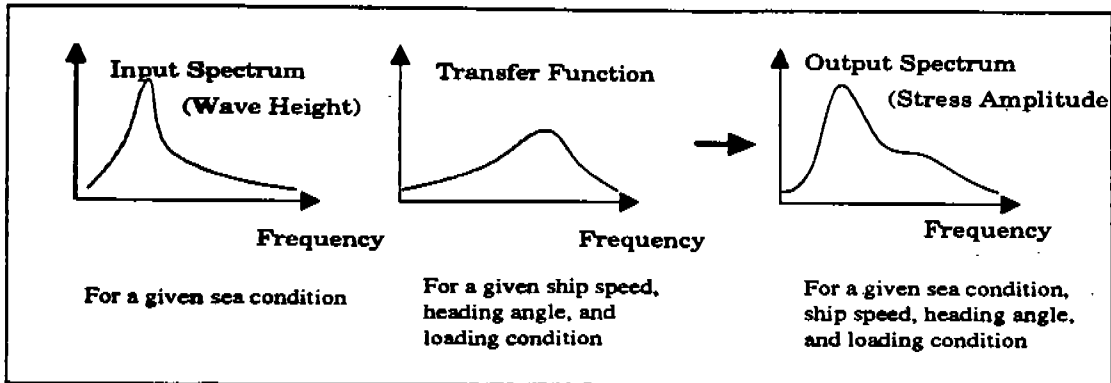


Figure 3.5: Stress range transfer function

### 3.3.5 Finite Element Analysis

To construct the stress range transfer function, one must determine the stress response under a unit amplitude wave at a certain frequency. Thus, the use of a finite element analysis (FEA) or beam theory is needed to calculate the response. Because of the complexity of a ship structure, a finite element analysis is the preferred approach to obtain fatigue stresses. The detail and extent of the finite element model must be determined by the particular category and location of CSD being analyzed.

FEA starts with a global 3-D coarse mesh model of the ship structure. Its forces, moments, and hydrodynamic pressure are obtained from the results of the ship motion analyses. One then constructs a local 3-D or 2-D model. The results (displacements) of the global FEA are used as the boundary conditions. This procedure of "zooming in" to the fatigue sensitive area in two, or perhaps three separate analysis steps can be more efficient than constructing a fine mesh model for the entire structure.

The other mean for obtaining local stresses at the "hot spots" (high stress areas) of the CSD is using an appropriate stress concentration factor (SCF) together with a nominal stress. This stress concentration factor may be estimated based on past analytical studies or experimental data.

### 3.3.6. Short-term & Long-term Probability Density Function

The distribution of fatigue stresses in any given sea state is constructed based on the wave energy spectrum for the sea state and the transfer function for the fatigue stress range at the location of interest. This distribution generally is assumed to be Rayleigh, with its parameter defined on the basis of the mean square value of the stress range process.

After weighting these short-term probability density functions (PDF) according to the likelihoods in wave scatter diagram, they can be summed up to form a long-term PDF. If the linear strip theory computations preserved the real and imaginary parts of the transfer functions (complex frequency response function), then the components can be linearly superimposed, the phases preserved through the complex transfer functions, and the resultant determined.

### 3.3.7 S-N Curves

The S-N (stress range v.s. number of cycles to failure) curve of a laboratory specimen which has the similar geometry and similar loading condition to the CSD will represent the fatigue capacity of the CSD. S-N curves are founded on statistical analyses of a large number of laboratory test data. Different curves, designated by letters B to W, represent different weld details (Fig. 3.7, 3.8). Welded joints relevant to ship structural details may be divided into various classes based on the joint and weld characteristics and also the orientation of the applied loads.

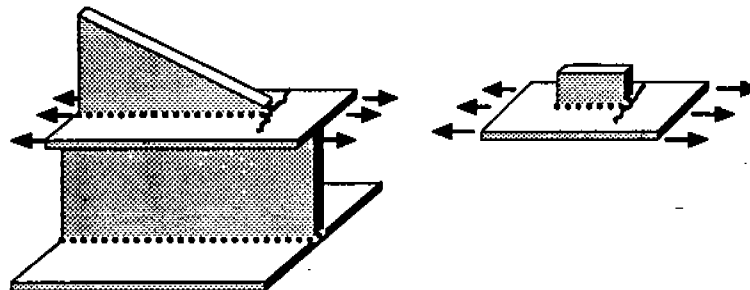


Figure 3.6: A ship structural detail and the corresponding class F fatigue specimen

An indication of the relationship between a ship structure detail and a laboratory fatigue specimen is given in Figure 3.6. The shown fatigue detail (the right picture) is classified into the class F by the U.K. Department of Energy. The eight S-N curves designated by B to W (Figure 3.7) are commonly used in fatigue assessment of hull structures. There are other sets of S-N curves available which are developed by different organizations. We can adopt the S-N curve of laboratory fatigue details for that of ship structural details.

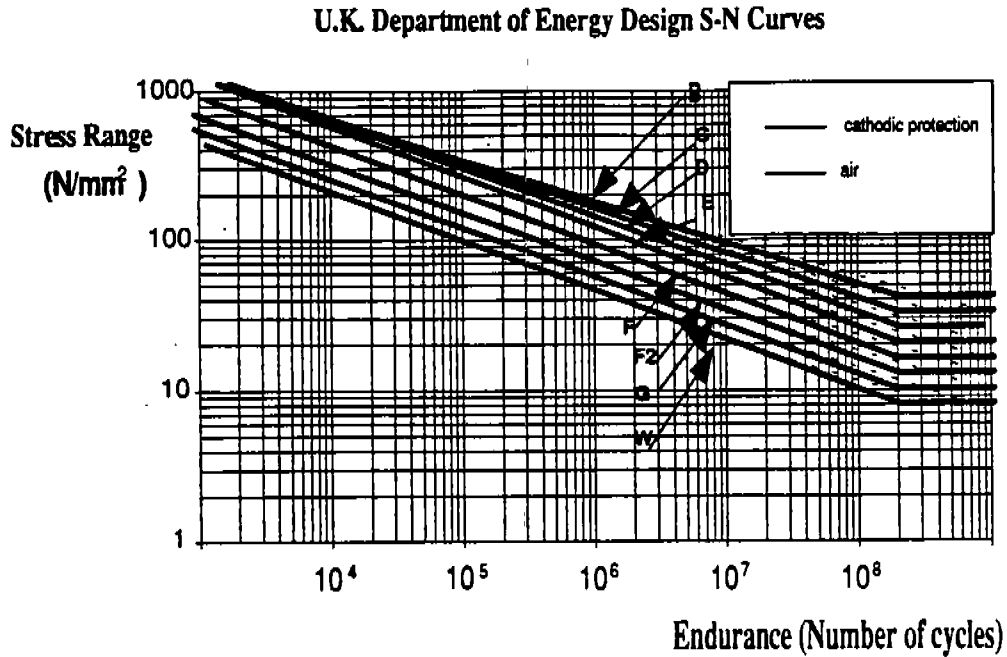


Figure 3.7: S-N curves

Table 3.4: The data of S-N relations

Class	m	C <sub>50</sub>	log s
B	4	2.343*10 <sup>15</sup>	0.1822
C	3.5	1.082*10 <sup>14</sup>	0.2041
D	3	3.988*10 <sup>12</sup>	0.2095
E	3	3.289*10 <sup>12</sup>	0.2509
F	3	1.726*10 <sup>12</sup>	0.2183
F2	3	1.231*10 <sup>12</sup>	0.2279
G	3	0.566*10 <sup>12</sup>	0.1793
W	3	0.368*10 <sup>12</sup>	0.1846

60



The U.K. DEn specifications provide tables relating to selection of S-N curves for any given structural detail situation. There is an amount of judgement involved in the selection of the appropriate S-N curve for any given case. For typical ship cases, guidance on the selection can be provided based on both experience and comparison with component test data for ship structural details.

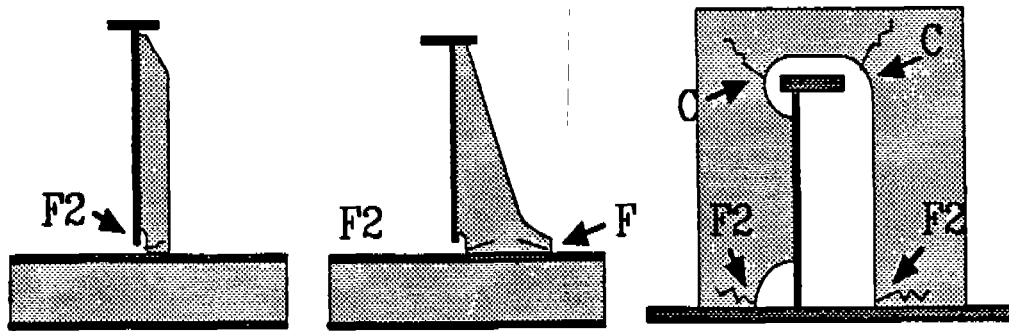


Figure 3.8: The relations between CSD and different class S-N curves

Scatter in fatigue data should be appropriately accounted for. Two standard deviations are normally deducted from mean S-N curve to be on the safe side of test results (Fig. 3.9), that is, 97.5% survival S-N curve is obtained

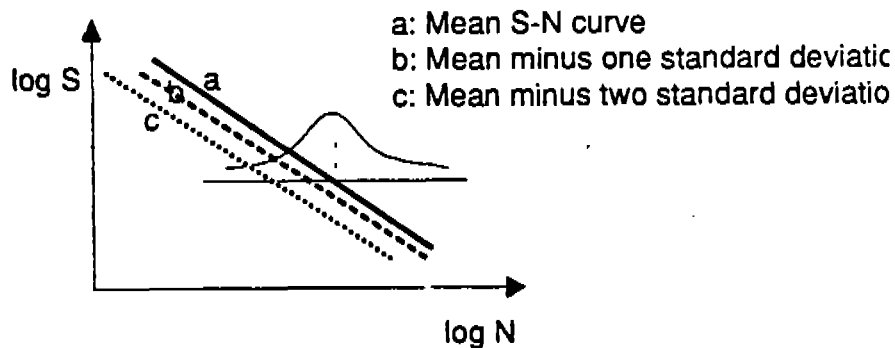


Figure 3.9: S-N curves with different reliability

S-N performance is also affected by the environment. When steel is subjected to cyclic stresses while in contact with a corrosive environment like sea water, the fatigue strength may be reduced as compared with the fatigue strength for the same number of cycles in air. In tankers, the rules now require coating in ballast tanks, so only cargo tanks without coating will potentially suffer this corrosion fatigue.

### 3.3.8 Damage Accumulation

Having selected the S-N curve and with the stress range histogram (or probability distributions) for the CSD, the resulting fatigue damage for the specified ship life can be computed through established techniques. In this process, damage accumulation under variable amplitude loading is treated using the Miner linear cumulative damage hypothesis, and a representative fatigue life can be obtained.

The fatigue strength of a structural detail subject to various cyclic stresses generally quantified by means of a damage factor, which provides a direct measure of how much of the structure's available strength has been used up along the way to possible fatigue failure. The damage factor can be calculated by means of the Miner-Palmgren linear cumulative damage hypothesis, which assumes that each stress cycle contributes a small increase of the damage factor and the total damage factor can be calculated by linear addition of the damage factor increments for the various cyclic stress levels.

Fatigue damage calculation according to Miner's rule may be done by dividing the long term distribution of stresses into blocks, each with assumed constant stress. The damage contribution from each block is calculated as  $n_i/N_i$  where  $n_i$  is number of load cycles in actual structure with stress range  $S_i$ , and  $N_i$  is the number of cycles to failure from appropriate S-N curve at same stress range. Summing up the contribution from each block gives accumulated damage. If the sum exceeds 1, fatigue failure is likely to occur within the estimated total load cycles.

$$U = \sum_{i=1..k} n_i/N_i$$

where  $k$  = Number of stress blocks,

$n_i$  = Number of stress cycles in stress block  $i$ ,

$N_i$  = Number of cycles to failure at constant stress range  $S_i$  within the stress block  $i$ .

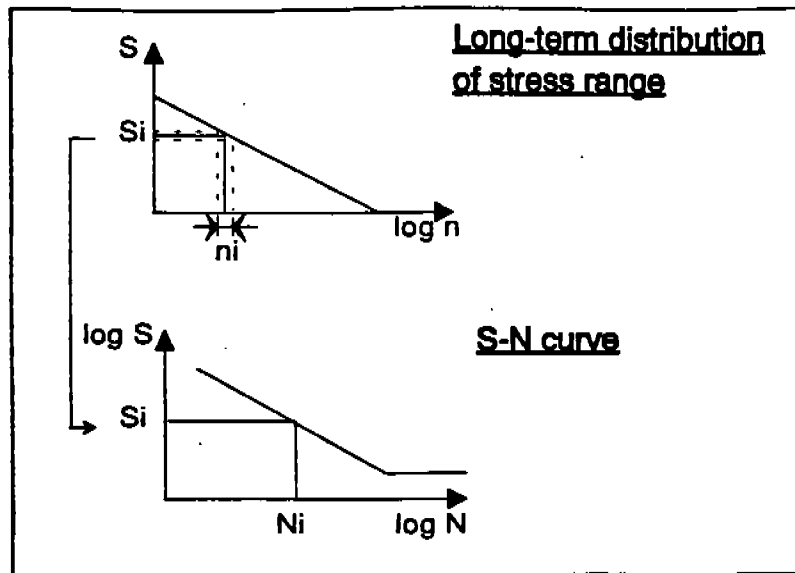


Figure 3.10: The Miner summation procedure for one particular stress block

A damage factor of 1.0 would correspond to fatigue failure for the specific period of time like 20 years of a ship's service life. A safety factor is usually incorporated in designing for fatigue, particularly in corrosive environments, in CSDs of high failure consequence, or in uninspectable situations.

There are many uncertainties involved in a fatigue analysis for CSD. Inherent variabilities come from the lifetime of sea states, headings, and speeds that will be developed and the cyclic stress range characteristics (S-N) performance of welded CSD. There are also model and parametric uncertainties that are associated with the determination of seaway loads (e.g., derived from linear "strip theory") and the determination of damage (linear, history independent damage accumulation law, e.g., Miner's rule). The natural variabilities and the model uncertainties result in highly uncertain results from fatigue analyses. These uncertainties can be managed through the application of liberal "factors of safety" and programmed inspections.

### 3.3.9 Damage Acceptability

Normally, a target fatigue life of 20 years or more is required of a new tanker. Thus, the target Miner sum is less than 1.0 in 20 years.

A fatigue analysis involves a large number of uncertainties and variabilities. When a fatigue analysis indicates a damage factor  $U=1$ , there is a very large uncertainty associated with this index.

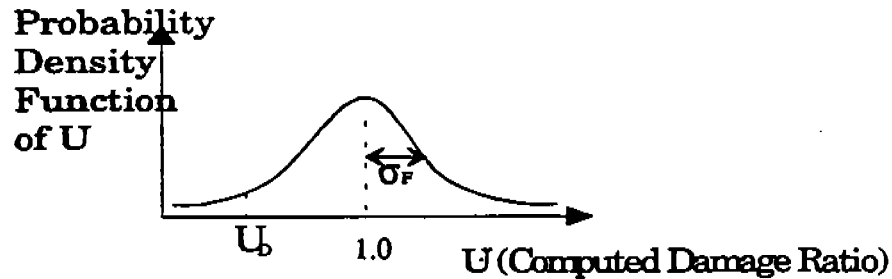


Figure 3.11: Probability density function of U

The choice of the S-N curve survival probability (Figure 3.11) generally makes the design damage factor a conservative indication of the expected damage factor required to cause significant cracking of a CSD. In a simplified format, the design damage factor,  $U_D$ , can be expressed as

$$U_D = U / FS_F$$

Where  $U$  is the expected damage factor at the first significant cracking and  $FS_F$  is the factor of safety for the fatigue design. The fatigue safety factor can be expressed simply as

$$FS_F = B^m \exp(\beta_F \sigma_F)$$

- where  $B$  = resultant bias (true / predicted) in true fatigue analysis,  
 $m$  = negative slope of the S-N curve,  
 $\beta_F$  = reliability required for CSD,  
 $\sigma_F$  = result uncertainty and variation in fatigue analysis.

For example, given a "biased" fatigue analysis procedure ( $B=2$ ), a desired likelihood of cracking of a CSD of 1/1000 ( $\beta_F=3$ ) and an uncertainty  $\sigma_F=1$ ,  $FS_F=2.5$ . This would mean that the design damage ratio should be a maximum value of  $U_D \leq 0.4$ .

64

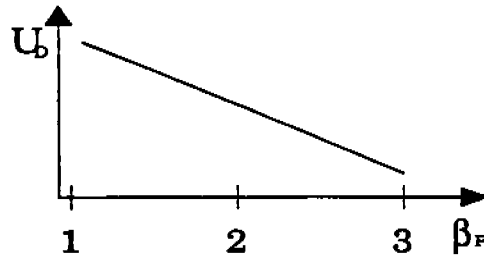


Figure 3.12:  $U_b$  as a function of the design reliability for  $B=2$  and  $\sigma_F=1$  (realistic values)

The design reliability is a function of the degree of durability that is needed to be incorporated into a CSD. The degree of durability is a function of initial and long-term maintenance costs (Figure 3.13).

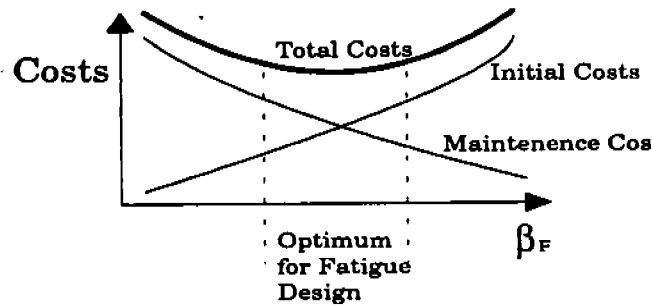


Figure 3.13: Optimum for fatigue design

### 3.4 Simplified Fatigue Analysis

Fatigue assessment may also base on simplified procedures, that is, using allowable fatigue stress analysis (AFSA). The major simplification is that we use a Weibull distribution to represent the long term distribution of stress range instead of going through the whole tedious procedures in a spectrum analysis. The long-term distribution of stress ranges is determined by only three parameters: Weibull shape parameter, the extreme stress range, and the number of cycles in 20 years, e.g. about  $10^8$ . Many other procedures, including the FEA needed, the S-N curves, etc., would essentially remain unchanged. Once the long-term distribution of stress ranges is determined and approximate S-N curve is chosen, the damage factor can be integrated by the Miner's rule. The damage factor, and hence the representative life, is obtained from a relatively simple equation that contains the S-N constants and the Weibull shape parameter.

4.5

### 3.4.1 Simplified Fatigue Analysis

The procedures of AFSA are listed as follows [3.17]:

1. Specify the Weibull shape parameter,
2. Specify design life time (or number of cycles in the life time),
3. Specify extreme stress range in the design life time (or characteristic stress range at some other exceeding level such as  $10^{-4}$ ),
4. Choose an S-N curve appropriate for the CSD, and
5. Calculate the damage factor.

### 3.4.2 Long-term Distribution of Stress Range

The AFSA requires that the complete loading history at the location of interest be presented in a probability distribution function. It is necessary to find a distribution which provides the best fit to the long-term ship loading histories. Full-scale ship stress collection programs have been conducted to determine the long-term distribution of stress range [3.5]. Some distributions obtained are shown in Figure 3.14. The figure shows measured long-term, low frequency, wave-induced ship hull girder stresses. It appears that most loading histories can be fit by Weibull distributions with the shape parameter,  $k$ , in the range of 0.7 to 1.3. The distribution with  $k=1$ , which is an exponential distribution, is a straight line on a semi-log plot. These distributions can be expressed as function  $S(N)$ , see the following equation. In the equation there are three parameters to be determined. They are Weibull shape parameter ' $k$ ', total number of stress cycles ' $N_0$ ' and maximum stress range during the entire ship life ' $S_0$ '.

$$S(N) = S_0 [ 1 - \log N / \log N_0 ]^{1/k}$$

where  $S_0$  = Maximum stress range in  $N$  stress ranges,  
 $N_0$  = Total number of stress cycles,  
 $N$  = Number of stress cycles which exceeds  $S$ ,  
 $k$  = Weibull shape parameter.

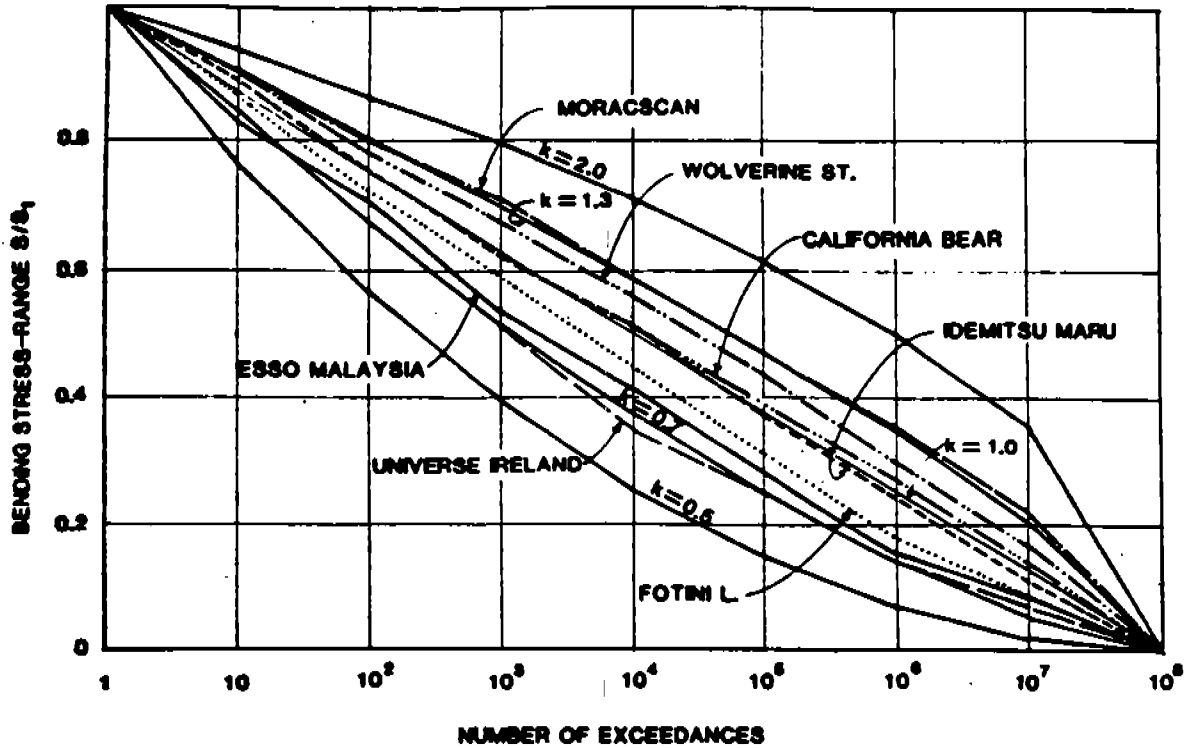


Figure 3.14: Long-term distribution of stress range of large tankers, bulk carriers and dry cargo vessels compared with Weibull

Weibull shape parameter characterizes the severity of the fatigue stresses. It depends on lots of factors, such as the encountered sea states, the detail geometry, the location of CSD in the ship, the strength of the ship,...and so on [3.14]. Among these factors, the strongest factor appears to be the severity of the wave environment. Until now, how to relate the Weibull shape parameter for a specified CSD and all those factors is still under investigation. The determination of the Weibull shape parameter is a critical step in the AFSA, since fatigue lives are extremely sensitive to it. For example, if  $k=1.0$ , fatigue life = 20 years; then if  $k=0.8$ , fatigue life could be as high as 64 years.

Fatigue lives are extremely sensitive to the stress range. Traditionally,  $10^{-8}$  exceedance level (or once in a lifetime) stress ranges have been used, assuming a 20 year life for the ship [3.16]. Unfortunately, for the same area or route of operation, a stress range at such an exceedance level can potentially vary depending on the particulars of the

67

wave data being used. For this reason, one can use a characteristic fatigue stress range at a low exceeding level, e.g.,  $10^{-4}$ . Experience indicates that the stress ranges calculated at such an exceedance level are more "robust". It can also be argued that such a "daily" stress range is more representative of fatigue.

## **3.5 Factors Influencing Fatigue Life**

### **3.5.1 Geometry of Member or Detail (Stress Concentration)**

Because of the way members are joined, discontinuities in geometry result and produce stress concentrations that cause increased local stresses when loads are applied. These stress concentrations can result from the general configuration of the structure, the local weld details, angular distortions or misalignment, and flaws that may occur within welds. For instance, the importance of the local geometry of weldments can be demonstrated by comparing the fatigue resistance of a butt welded splice with that of a basic plate at 2,000,000 cycles. The introduction of the butt weld reduces the fatigue resistance of the former to about 56 percent of that of the later [3.5].

Poor design of details results in hard spots and extreme stress risers which cause fatigue cracks. Reviewing the locations of cracks in ships, one will find that most cracks occurred on the local connection details. Generally, sharp corners, brackets with hard toes and insufficient surface/surface contact can result in failures.

The stress concentration factor (SCF) ( $K_{TOTAL}$ ) at the intersection of side shell longitudinals with transverse bulkhead or web can be defined as the ratio of the extreme stress around weld ( $S_{HOT}$ ) to the maximum nominal stress ( $S_N$ ) in the face plate of the longitudinal which is assumed as a one-spanned simple beam with both ends clamped [3.13].



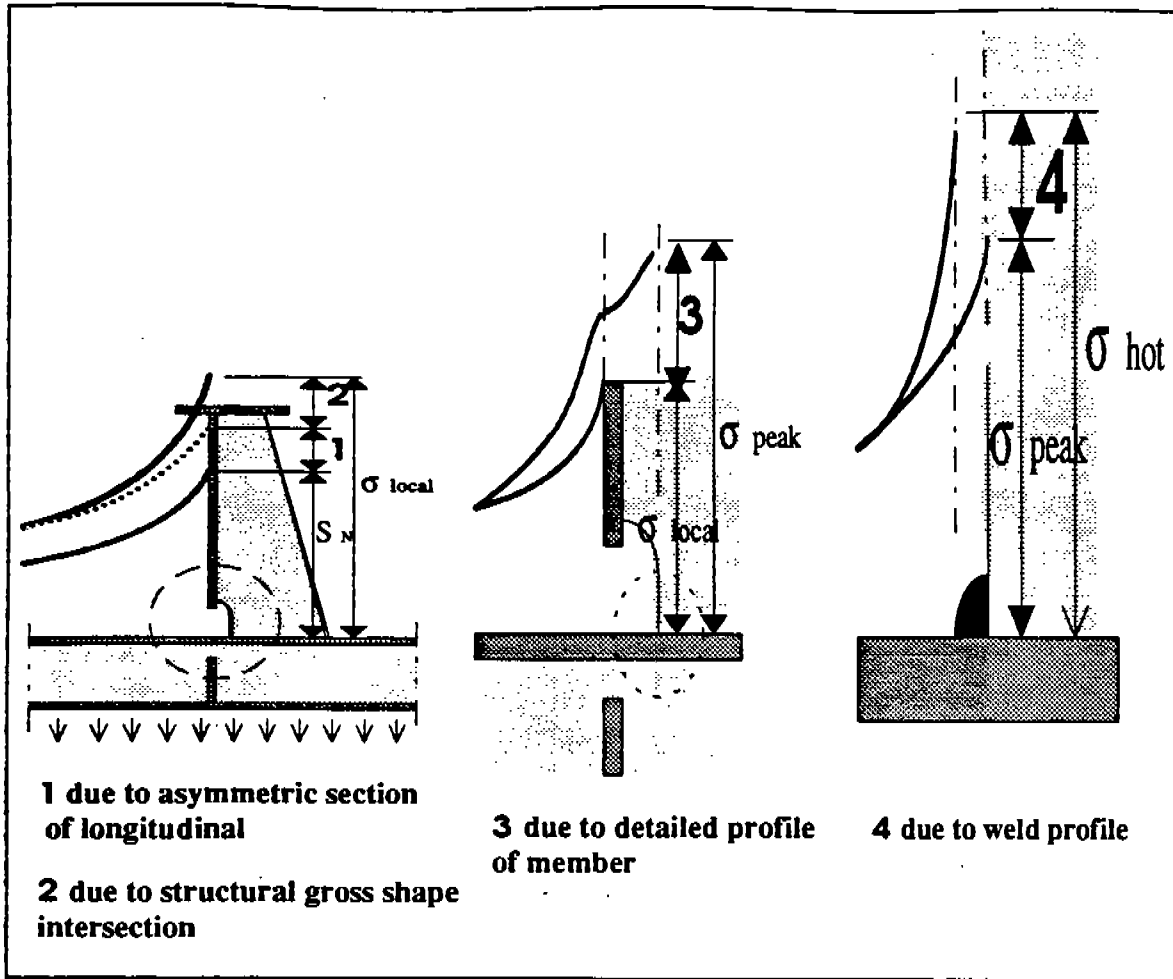


Figure 3.15: The definitions of SCF [3.13]

$$K_{GLOBAL} = \sigma_{LOCAL} / S_N$$

$$K_{LOCAL} = \sigma_{PEAK} / \sigma_{LOCAL}$$

$$K_{STRUCT} = K_{GLOBAL} K_{LOCAL}$$

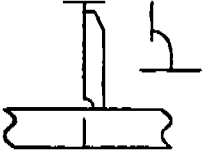
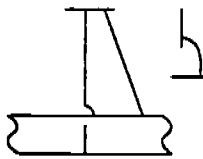
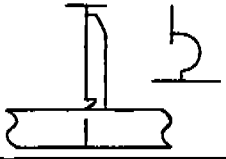
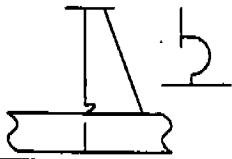
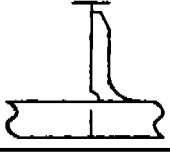
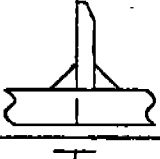
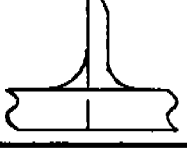
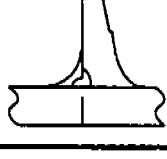
$$K_{WELD} = \sigma_{HOT} / \sigma_{PEAK}$$

$$K_{TOTAL} = (K_{GLOBAL} K_{LOCAL}) K_{WELD}$$

$$= K_{STRUCT} K_{WELD}$$

$K_{GLOBAL}$  and  $K_{LOCAL}$  which are due to structural gross and local shapes respectively at various types of intersection can be obtained from a series of detailed stress analysis by FEM. Figure 3.15 illustrates the definitions of stress concentration factors.

Table 3.5: Examples of SCF in different types of intersection [3.13]

Flat-bar stiffener			Tripping bracket		
Type of intersection	$K_{GLOBAL}$	$K_{STRUCT}$	Type of intersection	$K_{GLOBAL}$	$K_{STRUCT}$
	1.4	2.7		1.4	2.9
	1.4	1.8		1.4	2.0
	1.5	2.8	-	-	-
	0.7	2.3	-	-	-
	0.7	1.1		0.6	0.9

In addition to stress concentrations, the symmetry of section profile of details also has significant influence on fatigue strength. It was reported that some of the 2nd generation VLCC at the ages of only three to four years experienced fatigue cracks in way of side shell longitudinals with asymmetric section profile [3.13]. On the other hand, there is no fatigue crack found in another ship with side shell longitudinals with semi-symmetric section profile. Therefore, the influence of symmetry on the strength of longitudinals was investigated in [3.13]. One of the findings is that the maximum stress in the asymmetric configuration is nearly 70% higher than that in symmetric one. Thus it is clear that the stress relaxation by employing the side shell longitudinals of T or semi-T type section will improve fatigue strength greatly.

### 3.5.2 Material

High tensile steel has been used in ship building for many years. However until the mid 80's, high tensile steel was mainly used in bottom and deck. Of tankers built during the building boom in the 70's, a few tankers were built with high tensile steel also in side shell. Some of these vessels are now experiencing fatigue damages. Today, high tensile steel is normally utilized for all longitudinal material and to a great extent also for transverse structural elements within the cargo area.

However, there was a general consensus among the Trans-Alaska Pipeline Service (TAPS) operators that modern vessels, built within the last 20 years, which contain HTS have more problems than the older vessels constructed solely of mild steel [3.7]. The report indicates that tankers whose cargo block section is constructed of either a combination of mild and HTS or solely of HTS experienced disproportionately higher numbers of structural failures than vessels built only of mild steel.

Applying high tensile steel, scantlings are reduced and stresses increased. There is not a commensurate increase in the fatigue strength. While fatigue tests on smooth specimens in air indicate substantial increase in the fatigue strength with yield strength, fatigue tests on notched specimens and specimens in corrosive environments do not indicate any substantial increases in fatigue strength with increases in yield strength [3.23].

The allowable stress given by classification societies may be increased by a factor, denoted material factor. If for example HT36 steel is used, the allowable stress in longitudinals may generally be increased by 39% compared to stress level in mild steel. (The material factor employed by ABS for local scantlings is 0.72 for HT36 steel.) In structures subject to mainly static loads, this does not cause problems other than a reduced corrosion margin and perhaps increased vibrations and flexibility in some cases. However, in structure subject to dynamic loads such as side shell CSD, the increased stress levels have a significant implication: reduced fatigue life.

### 3.5.3 Construction Flaws

These include missing brackets, construction details in variance with approved plans, etc. Also, poor weld workmanship, including fabrication and fit-up during the construction of the vessel, results in additional stresses in butt and fillet welds.

There have been reports of shipyards using plates at the very low limit of the rolling tolerances (i.e., 19.5 mm plate used where 20 mm plate is specified). According to a survey [3.10], the results of gauging on some new vessels did show that the majority of all readings were down from original thicknesses, up to 0.4 to 0.5 mm with average loss of approximately 0.2 mm. The following table shows the distribution of loss as a percentage of all reading taken on a VLCC. The requirements for dimensional tolerances for major classification societies are basically the same and are as follows:

- Thickness not exceeding 15.0 mm: Tolerance of 0.4 mm
- Thickness not exceeding 45.0 mm: Tolerance of  $(0.02t + 0.1)$  mm
- Over 45 mm: Tolerance 1 mm

Comparing the survey readings to Class requirements, 9% of gauging taken are at tolerance or in excess, that is, 91% could be considered "acceptable".

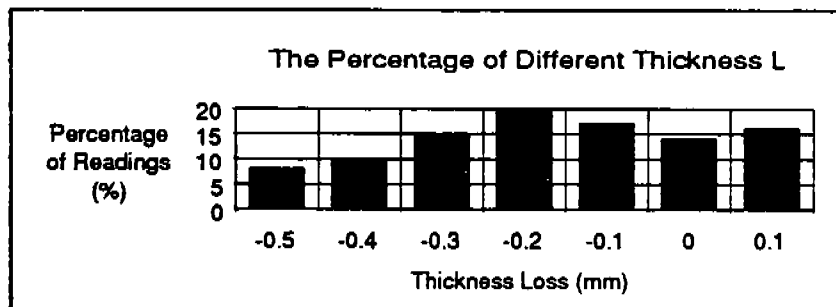


Figure 3.16: An example of mill tolerance [3.13]

There have also been cases of so-called 'rogue' or uncertified plates finding their way into the ship structure. In one such case, a plate intended for fabrication as a bulldozer blade was mixed into a shipment of certified plate and became part of the shell plate of a tanker with naturally unsatisfactory results [3.10].

## **3.6 Improved CSD Design**

Careful design of CSD is the single most important component in developing a durable ship structure. Included are aspects such as relocating welds away from high stress areas and reducing local stress levels through beneficial contours and soft toes. It is good practice to use service proven details. Also, wherever possible, details should be so configured that if local failures should occur, the crack does not readily propagate into the hull envelope. This section will introduce some techniques of detail design and illustrate good detail designs from bad ones in order to reduce fatigue damage.

### **3.6.1 Countermeasures Against Fatigue Failure**

The stresses which cause fatigue problem are mostly cyclic stresses in way of weld connections. Accordingly, fatigue life may basically be improved by reduce nominal stress or by relaxing stress concentrations and hot spots. Accordingly, the counter measures considered is listed below.

- Increase scantlings and thereby reduce the nominal stress.
- The symmetric section (T-type) of longitudinals can prevent additional local stresses due to torsional bending.
- Applying longer transition pieces, tapering the width of the transition pieces, and reducing geometrical discontinuities can relax stress concentrations (see Figure 3.17).
- Adding backing brackets to the opposite side of flat-bar stiffeners or tripping brackets can reduce additional stress due to lateral deformation of transverse webs (see Figure 3.18). The soft-typed scallop can be used to relax local stress concentration. It is usually installed at the heel of flat-bar stiffeners of tripping brackets. The degree of this relaxation also depends on the shape and the size of scallop, and about 35% stress decrease can be achieved as a maximum [3.13]. The peak stress will be indeed reduced, but it has not been proved that the fatigue strength at these more complex cutouts will increase accordingly.
- Using the design of soft toe (figure 3.17) and soft scallop (figure 3.20) can relax the local stress concentration. While a backing bracket is added to the opposite side of a tripping bracket or a flat-bar stiffener, the location of stress concentration will shift to the toe of the backing bracket. In the same time, the

stress level of shifted location of stress concentration will be much lower depending on the size and shape of the backing bracket. In case of using soft bracket, 65% decrease of local stress can be expected in the maximum. The stress relaxation by adding a backing bracket has significant effect. Although using a soft toe or fitting a bracket at the toe side of a flat-bar stiffener can reduce stress level there, it results in the stress increase at its heel side. However a soft toe is very effective in reducing stress levels. In its application, one should be careful not to cause another stress concentration.

- Grind the weld around bracket toes or heels to reduce stress concentration. An increase in fatigue life by a factor 2 is-potentially possible [3.16]. However, this technique is still not widely used because of the large number of CSDs.

### 3.6.2 Examples of Improved Detail Design

#### (1) Beam Brackets

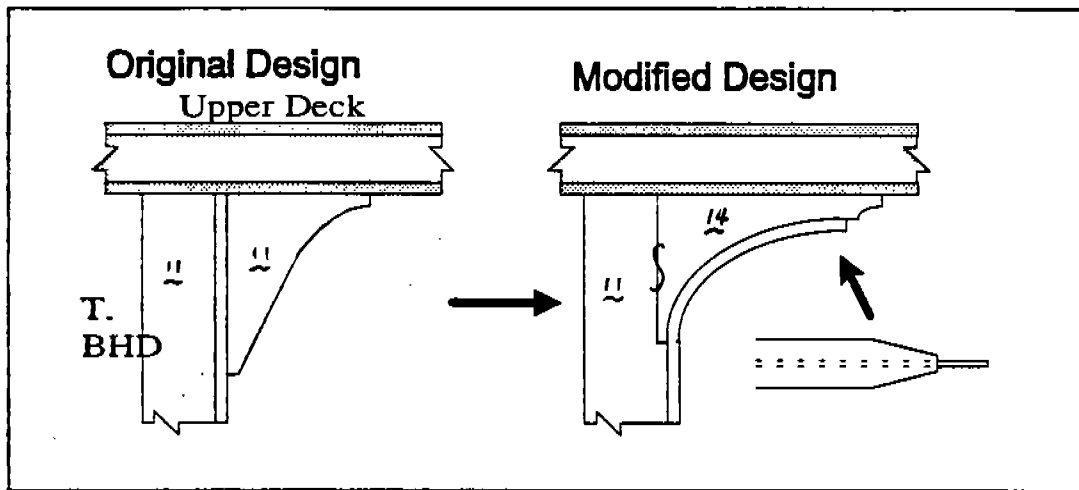


Figure 3.17: Decreasing discontinuity and using soft toe for a beam bracket

74

(2) Tripping Brackets

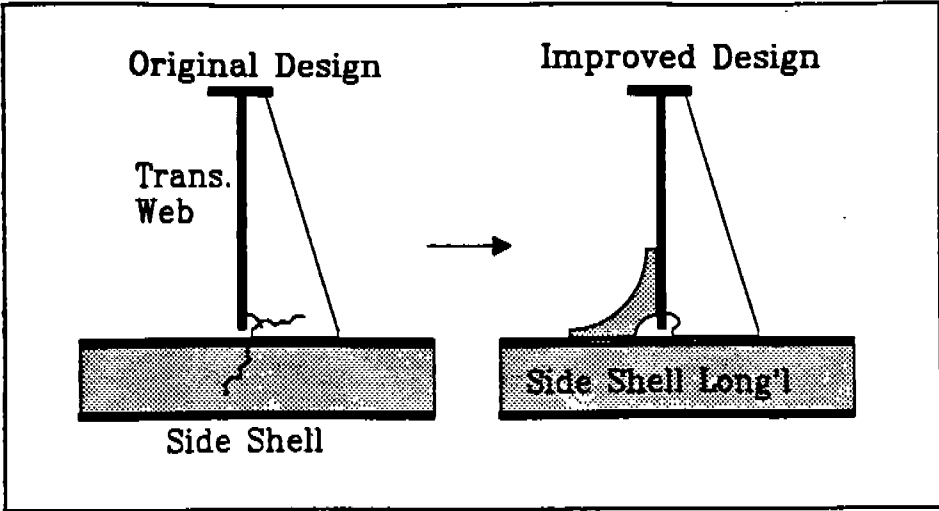


Figure 3.18: Adding a backing bracket for a tripping bracket

(3) Slot

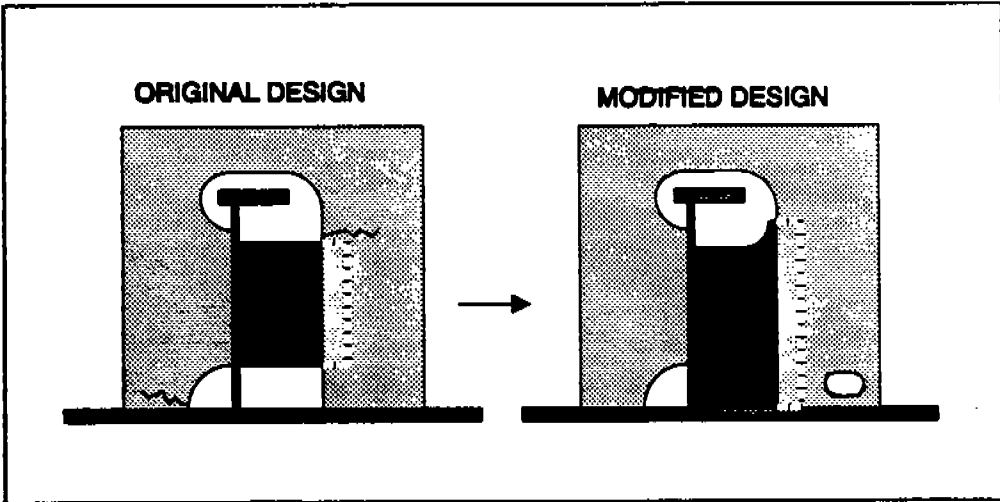


Figure 3.19: Using soft collar-ring plate and expanding it to reduce discontinuity for a slot

75

(4) Flat Bar Stiffeners

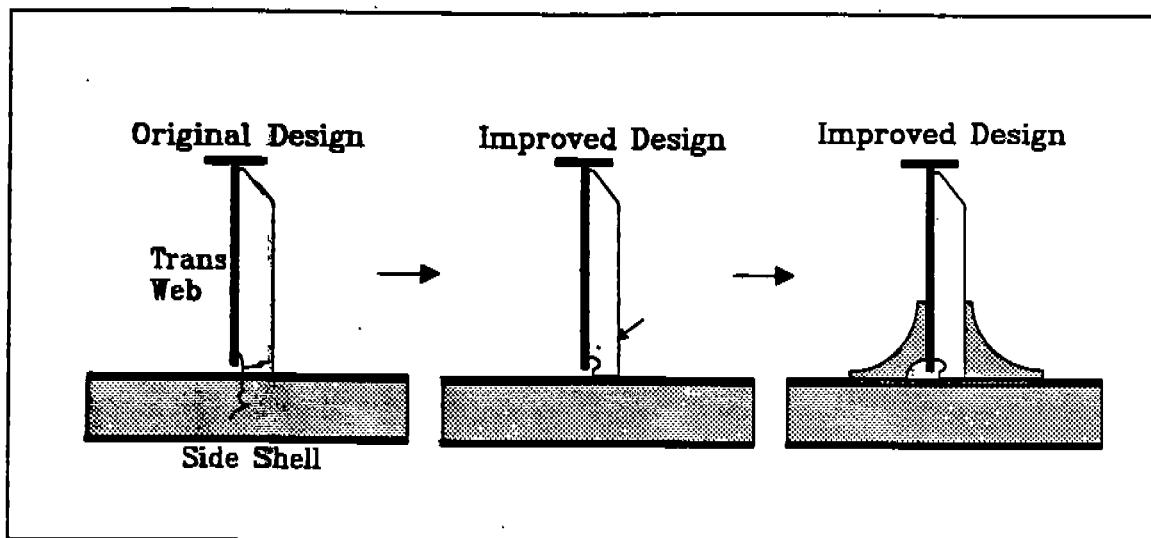


Figure 3.20: Using soft scallop (middle picture) and adding brackets (right picture) for a flat-bar stiffener

76



References:

- [3.1] Robert G. Bea, "Marine Structural Integrity Programs", Ship Structure Committee Report No. SSC-365, 1992.
- [3.2] Rolf Schulte-Strathaus, "Fatigue Database Development and Analysis", Project Report No. SMP-4, Structural Maintenance for New and Existing Ships, Dept. of Naval Architecture & Offshore Engineering, U.C. Berkeley, 1991.
- [3.3] Jordan, CR, Cochran, CS, Newport News Shipbuilding , "In-Service Performance of Structural Details", Ship Structure Committee, Report No. SSC-272, 1978.
- [3.4] Jordan, CR, Knight, LT, Newport News Shipbuilding , "Further Survey of In-Service Performance of Structural Details", Ship Structure Committee, Report No. SSC-294, 1980
- [3.5] Munse, WH, Wilbur, TW, Tellalian, ML, Nicoll, K, Wilson, K, Dept. of Civil Engineering, "Fatigue Characterization of Fabricate Ship Details for Design", Ship Structure Committee, Report No. SSC-318, 1983
- [3.6] J. T. Balczewski, "Fatigue and Corrosion in VLCC's", 1990
- [3.7] J. D. Sipes, et al., "Trans-Alaska Pipeline Service (TAPS) Tanker Structural Failure Study", U. S. Coast Guard, 1990.
- [3.8] Committee III.1 Report, Proceedings of the Seventh International Ship Structures Congress, Paris, 1979
- [3.9] Kjellander, S. L. "Hull Damages on Large Swedish-Built Ships", 1972.
- [3.10] Tanker Structure Co-operative Forum, "Work Shop Report: Mill Tolerance Study", 1991.
- [3.11] Nordenstrom, N. "A Method to Predict Long-term Distributions of Waves and Wave-Induced Motions and Loads on Ships and Other Floating Structures", Det Norske Veritas, Pub. 1. No.81, April 1973
- [3.12] U.K. Department of Energy, "Offshore Installations: Guidance on Design, Construction and Certification", Fourth Ed. HMSO, London, 1990.
- [3.13] Tanker Structure Co-operative Forum, "Work Shop Report: Fatigue Life of High Tensile Steel Structures", 1991.
- [3.14] Rober G. Bea, "Reliability Based Design Criteria for Coastal and Ocean Structures", Institution of Engineers Australia, Barton ACT, 1990.
- [3.15] Taggart, SNAME, "Ship Design and Construction", 1980.
- [3.16] Anil K. Thayamballi, ABS, "Fatigue Analysis of Tankers", RD-89020F, ABS Far East Technical Seminars, 1989

### Chapter 3 Fatigue Considerations

- [3.17] Y. N. Chen, ABS, "Fatigue Analysis and Assessment of Ship Structures", RD-89010, ABS Presentation at the TAPS Meeting, 1989
- [3.18] Little, R. S., and Lewis, E. V., "A Statistical Study of Wave-Induced Bending Moments on Large Oceangoing Tankers and Bulk Carriers," Transactions, SNAME, 1971.
- [3.19] British Maritime Technology, "Global Wave Statistics," 1986.
- [3.20] Oliver, J. C., "Advanced Methods for Ship Motion and Wave Load Prediction," Ship Structure Committee Report No. SSC-333, 1990.
- [3.21] Hachman, D., "Calculation of Pressures on a Ship's Hull in Waves," Ship Technology Research, Vol. 38, 1991.
- [3.22] Huss, M, "Combined Wave Induced Stresses in a Lo/Lo Container Ship," The Royal Institute of Technology, Stockholm, Report TRITA-SKJP 1059, 1987.
- [3.23] DNV, "Note on Fatigue Damages of Ship Structure and Fatigue Control Requirements in DNV Rules," Technical Bulletin, Approval Center for East Asia, Pusan Korea, 1991.
- [3.24] Lewis, SNAME, "Principles of Naval Architecture, Vol. 1", 1988

# Chapter 4 Inspection and Monitoring

## 4.0 Introduction

The objective of this chapter is to summarize important inspection and monitoring considerations as they apply to the internal critical structural details of new builds including how the internal structure of new builds can be designed and configured to enhance inspections. In addition, this chapter will describe onboard monitoring systems that can be used to provide information to improve ship maintenance and design.

### 4.0.1 Objectives of Inspection

The objective of inspection is to acquire information and knowledge concerning the integrity of the ship hull structure. Two inspection phases will be discussed in this Chapter: construction and in-service.

With the introduction of VLCC's, the task of conducting structural inspections has become increasingly difficult. The larger size of vessels has increased the surface area that needs to be inspected to an almost unrealistic level. In a VLCC, there can be 150 to 200 acres of steel, 200 to 300 miles of welds, and 30 to 40 miles of stiffeners to be inspected [4.1]. As a result a result of the difficulties associated with performing inspections, the percentage of structural defects detected decreases and the personnel safety problem associated with inspections increases.

In the first part of this chapter, inspection methods and concepts are introduced. The quality controls of structure and coating during construction inspection are described first. After that, in-service inspection is introduced. The inspection procedure including preparation, execution and data analysis is discussed. Lastly, design considerations for accessibility and ventilation are also introduced.

## 4.0.2 Objectives of Monitoring

Hull structural monitoring systems have become a potentially important part of tanker inspection technology. Such systems can provide intermittent and continuous data on the performance responses of the hull structure. They can provide important information to improve design, construction, and operations of the ships. Onboard monitoring systems are particularly useful in that they allow the Master/watch officer to quantify the results of an action taken to minimize the response of the ship to seaway-induced loading. Such actions can include changing ship's heading, speed, and ballast to a deeper draft. By observing the bridge display monitor, the effect of initiating such an action on, say, main deck stress, can be readily determined. Ship monitoring systems can also provide ship designers with prototype data on loading and ship structure responses to help improve the technologies of seaway loading predictions and prediction of ship structure responses to these loads. Ship inspections and structure maintenance also benefit from the improvements provided by monitoring systems.

## 4.1 Construction Inspections

### 4.1.1 Structure

Construction inspections are intended to assure that specified structural materials, dimensions, positioning, surface and weld preparations, welding sequence, fit-up and alignment have been followed during the construction of the ship. Experience has amply demonstrated that the quality of the construction will be reflected directly in the durability of the ship structure and in its ability to remain serviceable throughout its lifetime, particularly after the first few years of the ship's service. Compromises in the quality of the ship structure during construction are reflected in structural durability problems later in the life of the ship.

All necessary inspection shall be carried out in accordance with the contract, contract specifications and this inspection standard. The inspection shall be carried out by the Builder in accordance with the Builder's working schedule. The owner inspector may attend such inspection as are required to be witnessed by the owner inspector in accordance with the list of inspection and testing of this inspection standard. Those inspections which are scheduled to carry out prior to the arrival of the owner's inspector

at the shipyard shall be carried out by the builder alone. If the owner's inspector finds any non-conformity to the contract or specification, he/she shall inform the shipyard as early as possible so that the builder may rectify such non-conformity without big disturbance to the construction schedule.

The inspection of hull construction consists of several phases. First, the fit-up inspection is carried out before the commencement of welding. When the construction of each block is finished, the hull block inspection then follows. If any fittings are fitted to the hull block, the hull block inspection shall be carried out without dismantling these fittings unless they make the inspection impossible. When all works affecting strength and tightness of the hull construction are completed, the internal inspection of the hull construction work shall be carried out. If outfitting works in these spaces are left unfinished, the final inspection of these works shall be carried out when all outfitting works are completed.

Hydrostatic test or air tight test should be carried out for each tank compartment after finishing the internal inspection before launching. For those tanks which cannot have hydrostatic test before launching, the vacuum test and the air leakage test of fillet welded joints shall be carried out at the assembly stage or the erection stage.

Inspectors should look for any defect that could happen during construction. Generally, inspectors should pay strict attention to the following items:

- **Missing components:** Inspectors should ensure the hull structure is built in accordance with the approved plans. Make sure there are no missing components or incorrect positioning of structural members..
- **Thickness and material of steel plates:** Inspectors should verify that the thickness and grade of steel plate is in accordance with the specifications/plans.
- **Alignment of structure:** One of the problems in assembly work is to ensure proper fit-up and alignment of one assembly with another. This should be checked and verified by inspectors.
- **Welding sequence:** Inspectors must ensure compliance with the welding sequence. The overall welding sequence should be considered primarily from the point of view of minimizing distortion, avoiding stress concentrations and facilitating fabrication. It is also aimed at minimizing the chance of cracking during the welding process in areas of high restraint.

- **Welding quality:** The most common types of defects in a weld include cracks, incomplete fusion, lack of penetration, slag inclusion, porosity, and under cut. If these defects are not caught by inspectors, they may become future maintenance problems. The likelihood of these defects is somewhat dependent on the workmanship. However, the quality of welding is affected by many factors and is not restricted to the work done by the welder alone. Before welding, all of the earlier steps such as layout, plate edge preparation, fitting, and alignment should have been planned with regard to securing good workmanship. The shipyard is responsible for providing a good workmanship. However it is the inspector's responsibility to insure the quality.

The first level of construction inspections are the quality standard and inspection procedures that are specified in new building contract and specifications by the ship owner. The second level are those specified and followed by the ship yard. The third level of construction inspections are those specified and performed by regulatory authorities and ship classification societies. The quality assurance and control procedures that are provided by the ship yards, regulatory authorities and classification societies are used as components of this foundation. Construction inspectors must be well trained and diligent. Positive incentives should be provided to assure that all parties do what is necessary to achieve the ship structure quality goals.

The primary means of construction inspections are visual, to compare the construction drawings and specifications with what is being done by the shipyard on a daily basis. Access to the areas to be inspected, proper lighting and ventilation, and inspector training are critical aspects of these inspections. Color coding different grades and types of steels and different types of welding materials can help assure that the proper materials are being used.

However, fundamentally all steels look alike, it is difficult to detect weld flaws (lack of penetration, porosity) under the weld cap passes, and frequently misalignments can not be detected because of an inability to "see through steel." Thus, non-destructive testing (NDT) methods such as dye penetrant, ultrasonic, magnetic particle, and radiography must be used. Table 4.1 summarizes the advantages and disadvantages and applications of alternative NDT methods.

During the design stage it is also important to have the engineers specify quality standard and acceptable deviations. This includes items such as weld quality and profiles, material thickness, and alignments. The data taking, recording, and verification plans should also be developed during the design stage.

**Table 4.1: Summary of non-destructive testing methods [4.1]**

INSPECTION METHODS	EQUIPMENT	TO DETECT	ADVANTAGE	DISADVANT.	COMMENTS
VISUAL	Magnifying glass Weld-size gauge Pocket rule Straight edge Workmanship standards Pit gauge	Surface Flaws Warpage Under-welding Poor profile Improper fit-up Misalignment	Low cost Apply while work in prog. Indication of incorrect procedures	Surface defects only No permanent record	Primary means of inspection
RADIO-GRAPHIC	Commercial X-ray or gamma units Film processing unit Fluoroscopic viewing equip.	Interior Macroscopic flaws	Permanent Record	Skill needed to achieve good results Safety precautions Not suitable for fillet welds Costly	Required by many codes and specs. Useful in qualifying welders
MAGNETIC-PARTICLE	Commercial MPI units Powers, dry, wet, fluorescent for UV light	Surface discontinuities	Simpler than radiographic Permits controlled sensitivity Relatively low cost	Applicable to ferromagnetic materials Requires skill in interpretations Difficult to use on rough surf.	Elongated defects parallel to magnetic may not give pattern
LIQUID PENETRANT	Commercial kits containing fluorescent or dye penetrants Source of UV light	Surface cracks Excellent for locating leaks in weldments	Applicable to magnetic, non-magnetic materials Easy to use Low Cost	Only surface defects detect Cannot be used on hot assemblies	Irrelevant surface conditions may give misleading indications
ULTRA-SONIC	Special commercial equipment of the pulse-echo or transmission type Standard reference patterns for interpretation of RF or video patterns	Surface and subsurface flaws and laminations	Very sensitive Permits probing of joints	Requires high degree of skill in interpreting pulse echo patterns Permanent record not readily obtained	Pulse-echo equipment is highly developed Transmission-type equipment simplified pattern interpretation

### 4.1.2 Coatings

Once the coating is completed, it is almost impossible for ship owners to examine the quality of the coating work. Therefore, quality control during coating procedures is critical. Quality control on corrosion prevention can be done by the supervision of ship owners, paint manufacturers and the workmanship of ship yards. The inspection provided by ship owners influences dramatically the quality of new ships. Generally some supervisors will be sent by ship owners to the ship yard to inspect the construction of their new ships during the whole period. These inspectors should be well trained and have sufficient experience to make sure that all the work is completed to the satisfaction of the owners. On the other hand, ship yards have the responsibility to assure the quality of their products. The workmanship of different ship yards differs from each other. Controlling the shipyard's workmanship therefore becomes a fundamental responsibility of the inspector/owner's representative. (Refer to Chapter 2 for more information)

The causes of coating failures that construction and repair supervisors and inspectors should pay special attention on are listed below:

- (a) Inadequate surface preparation,
- (b) Inadequate storage after blast-cleaning that causes corrosion again,
- (c) Inadequate working temperature or humidity,
- (d) Incorrect drying periods between applications of successive coatings,
- (e) Coating omission on the corners of structural details (See Figure 4.1),
- (f) Poor application procedures,
- (g) Insufficient film thickness,
- (h) Inadequate or omission of stripe coats,
- (i) Use of improper application equipment,

**Figure 4.1: Common areas of coating missing**



For inspection convenience in tanks, it is better to use a lighter color. It is easier to inspect cracks or coating defects (rust streaks and areas of coating breakdown) on lighter color coatings. If a two-coat system is chosen, it is common practice to use different colors for each layer of coating to distinguish them and to specify the thickness of each coat and ensure complete coverage.

## **4.2 In-service Inspections**

After a new ship is delivered, the ship's hull structure must be monitored by a series of internal and external inspections to assess the integrity of the ship structure. In-service inspections provide means to evaluate the current condition of steel and coatings and to detect unexpected flaws and damages, and permit appropriate maintenance and repair measures to be taken to preserve the integrity of the hull structure. A complete survey can be divided into three phases: planning and preparation, the execution of the actual survey, and data analysis.

### **4.2.1 Planning and Preparation**

Before an inspection, appropriate planning and preparation are important. The purpose of the inspection should be identified as one of the following [4.16]:

- **Flag administration requirements**
- **Classification societies' statutory requirements**
  - Special survey
  - Intermediate survey
  - Annual survey
  - Damage condition survey
- **Owner inspection requirements**
  - Corrosion trends survey
  - Pre-periodic overhaul planning
  - Pre-purchasing condition appraisal
  - Life continuance planning
  - Structural defects/fractures detection
  - Coating Assessment

## Inspection Programs

An inspection program begins when the vessel is delivered and continues throughout the life of the vessel. The purpose of inspections is to assess the capability of the structure to remain safe until the next inspection period and to accomplish any necessary corrective measures to maintain this capability. The effectiveness of inspection is dependent on the method of inspection, accessibility, and the qualification of the inspectors. Training inspectors, improving the inspection method, and improving accessibility will increase the percentage of critical structural details that are inspected.

The scope of internal structural inspections as required by the Classification Societies is listed in the following Table 4.2, 4.3, and 4.4 [4.3]. In this table, it can be seen that the extent of the requirement increases with the age of the ship. An overall survey is a survey intended to report on the overall condition of the tanks' structural integrity and corrosion condition in a relatively short period of time and to determine the extent of additional close-up surveys requirements. A close-up survey is one where the structural components are within the inspection range (within arm's reach) of the surveyor. In practice, the areas that will be inspected first will be those that are most accessible. However, as the age of the ship increases, additional access for close-up inspection will be necessary for most areas of the structure. This close-up survey is particularly necessary for crack detection, corrosion assessment and thickness measurement.

The minimum requirements for thickness measurements can be found in Reference [4.3]. The number of locations and extent of surveys are greater in the permanent ballast tanks and in tanks used primarily for water ballast because these tanks are subjected to a more corrosive environment. In addition to the thickness measurement specified in precise locations, sufficient measurements are required to assess and record corrosion patterns.

Table 4.2: Inspection program [4.3]

Age < 5 years Special Survey No. 1	5 < Age < 10 Special Survey No. 2	10 < Age < 15 Special Survey No. 3	15 < Age < 20 Special Survey No.4
<p>1. Overall Survey of all tanks and spaces</p> <p>2. Close-up Survey:</p> <p>a) One complete transverse web frame ring including adjacent structural members (in one ballast tank if any, or a cargo tank used primarily for water ballast)</p> <p>b) One deck transverse including adjacent deck structural members in one cargo wing tank</p> <p>c) Lower part of the girder system including adjacent structural members on one transverse bulkhead in one ballast tank, one cargo wing tank and one cargo center tank</p>	<p>1. Overall Survey of all tanks and spaces</p> <p>2. Close-up Survey:</p> <p>a) One complete transverse web frame ring including adjacent structural members in one wing (in one ballast tank if any, or a cargo tank used primarily for water ballast)</p> <p>b) One deck transverse including adjacent deck structural members in each of the remaining ballast tank, if any</p> <p>c) One deck transverse including adjacent deck structure in one cargo wing tank and two cargo center tanks</p> <p>d) The complete girder system including adjacent structural members on the transverse bulkheads in one wing tank (in one ballast tank, if any, or a cargo tank used primarily for water ballast)</p> <p>e) Lower part of the girder system including adjacent structural members on one transverse bulkhead in each of the remaining ballast tanks, one cargo wing tank and two cargo center tank</p>	<p>1. Overall Survey of all tanks and spaces</p> <p>2. Close-up Survey:</p> <p>a) All complete transverse web frame rings including adjacent structural members in all ballast tank and in one cargo wing tank</p> <p>b) One complete transverse web frame ring including adjacent structural members in each remaining cargo wing tanks and one bottom and one deck transverse in each cargo center tank</p> <p>c) One complete girder system including adjacent structural members on the transverse bulkheads in all cargo and ballast tanks</p>	<p>1. Overall Survey of all tanks and spaces</p> <p>2. Close-up Survey: as for Special Survey No. 3 with additional transverses as deemed necessary by the Surveyor</p>

**Table 4.3: Minimum requirements of thickness measurements at special hull surveys of oil tankers [4.3]**

Age < 5 years Special Survey No. 1	5 < Age < 10 Special Survey No. 2	10 < Age < 15 Special Survey No. 3	15 < Age < 20 Special Survey No.4
<p>1. One section of deck plating for the full beam of the ship within 0.5 L amidships (in way of a ballast tank, if any, or a cargo tank used primarily for water ballast)</p> <p>2. Sufficient measurements of structural members subject to Close-up Survey for general assessment and recording of corrosion pattern</p> <p>3. Suspect areas</p>	<p>1. Within 0.5 L amidships: a) Each deck plate b) One transverse section</p> <p>2. Sufficient measurements of the different structural members subject to Close-up Survey for general assessment and recording of corrosion pattern</p> <p>3. Suspect areas</p> <p>4. Selected wind and water strakes outside 0.5 L amidships</p>	<p>1. Within 0.5 L amidships: a) Each deck plate b) Two transverse sections</p> <p>2. Sufficient measures of the different structural members subject to Close-up Survey for general assessment and recording of corrosion pattern</p> <p>3. Suspect Areas</p> <p>4. Selected wind and water strakes outside 0.5 L amidships</p>	<p>1. Within 0.5 L amidships: a) Each deck plate b) Three transverse sections c) Each bottom plate</p> <p>2. Sufficient measurements of the different structural members subject to Close-up Survey for general assessment and recording of corrosion pattern</p> <p>3. Suspect areas</p> <p>4. Selected wind and water strakes outside 0.5 L amidships</p>

**Table 4.4: Minimum requirements of tank testing at special hull surveys of oil tankers [4.3]**

Age < 5 years Special Survey No. 1	5 < Age < 10 Special Survey No. 2	10 < Age < 15 Special Survey No. 3	15 < Age < 20 Special Survey No.4
<p>1. Cargo tank boundaries facing ballast tanks, void spaces, pipe tunnels, fuel oil tanks, pump rooms or cofferdams</p>	<p>1. Cargo tank boundaries facing ballast tanks, void spaces, pipe tunnels, fuel oil tanks, pump rooms or cofferdams</p> <p>2. All cargo tank bulkheads which form the boundaries of segregated cargoes</p>	<p>1. Cargo tank boundaries facing ballast tanks, void spaces, pipe tunnels, fuel oil tanks, pump rooms or cofferdams</p> <p>2. All remaining cargo tank bulkheads</p>	<p>Cargo tank boundaries facing ballast tanks, void spaces, pipe tunnels, fuel oil tanks, pump rooms or cofferdams</p> <p>2. All remaining cargo tank bulkheads</p>

### **What to Inspect**

The scope of the inspection is dependent on the inspection program. For each inspection, the extent of areas to be inspected should be specified. Generally, four basic defects will be recorded during all types of inspection. They are cracking, corrosion, coating breakdown and buckling. Additionally the inspector assesses the following conditions:

- Coatings and corrosion rates,
- Pitting and percentage of pitting covering the plate,
- Piping and fittings,
- Handrails, ladders, and walkways,

### **Where to Inspect**

Since a ship structure is large, it is almost impossible to perform a 100% inspection. The inspectors must have a good understanding of the structural layout and crack history of this ship. Information should be obtained prior to the commencing of the survey. This includes structural drawings, previous inspection data, previous repair records, condition and extent of protective coatings, operational history, and so on. Combining this information with the inspectors' experience, they can determine where to inspect more efficiently.

In addition, inspectors need to know the locations of critical structural details with high likelihoods of failure. Discussion with all involved parties, including the ship's staff, classification society, and ship representatives, can give inspectors insight into the locations of critical areas. If an inspection database is available, it will give inspectors further insight into where and when to expect structural damage and defects. Areas that are of concern to the inspector with respect to fracture initiation are listed below [4.3]:

- Ends of principal girders, stringers, transverses and struts with associated brackets. Particular attention should be paid to toes of brackets.
- Bracketed ends to shell, deck and bulkhead stiffeners.

- **Connection of shell, deck and bulkhead longitudinals to transverse web frames and bulkheads.** Particular attention should be paid to the side shell connections between full load and ballast waterlines.
- **Any discontinuity in the form of misalignment or abrupt changes of section.**
- **Plating in way of cutouts and openings.**
- **Areas that show any evidence of damage or buckling.**
- **Erection butts in plating and longitudinal stiffeners.**

For corrosion concern, the bottom is perhaps the most commonly inspected area in a tanker. The extent of wastage should be checked. For coated tanks, wastage will take the form of localized pitting and grooving in way of coating failure. Generally, inspections for localized corrosion can be focused in the following areas:

- **Top and bottom of ballast tanks,**
- **Bottom of cargo tanks where pitting corrosion could occur,**
- **Any horizontal surface which can entrap water, in particular, horizontal stringers on transverse bulkheads,**
- **Welds, sharp edges, and any areas in which coating is difficult to apply,**
- **Local stiffening members which can become the sites of grooving corrosion, and**
- **Zinc Anodes.**

A good way to keep track of the trend of critical areas is to use a computerized database system. A computerized database system is used for typical defect documentation and inspection results. It can simplify the handling of gauging and inspection data. Besides, developing high quality databases on corrosion and cracking histories and containing sufficient volumes of data can assist in defining the areas of the hull structure that should be closely inspected and monitored on a more frequent basis.

#### **4.2.2 Execution of Survey**

After the planning and preparation, the execution of the survey can begin. A sequence of tasks should be completed before inspectors enter tanks. The tanks must be cleaned. Ventilation facilities should then be installed to prevent gas hazard to the inspectors. A fundamental problem that inspectors will meet is satisfactory access to structural details. Thus different access methods will be introduced. While the

inspection is under going, inspectors will need to record the defects they find. Several data recording methods will be introduced in this section.

### **Tank Cleaning**

Before a survey, tanks to be inspected must be cleaned. The effectiveness of the tank cleaning is the most important factor contributing to the success of a structural survey. The water in the ballast tanks must be pumped out. There is typically a layer of mud left on all horizontal surface. It is hard to remove. On the other hand, the surfaces in cargo tanks could have a layer of wax or cargo residue (sludge) left after cargo oil is pumped out. All the mud, wax or standing water will hide structural defects. Insufficiently cleaned tanks will not only prevent a good visual and ultrasonic survey but will also increase the hazards faced by the inspectors from hydrocarbon levels and slippery structure faced by the inspectors. Tank cleaning can be performed with an existing Crude Oil Washing (COW) system. Sediment and sludge may still be a problem in shadow areas and perhaps on the bottom, and in this case crew assistance in sludge removal by using shovels, scrapers and buckets may be necessary.

### **Ventilation and Lighting**

The risks of hazardous vapors, suffocation, fire and explosions are controlled by conventional gas freeing, cleaning and ventilating. Before entering tanks, gas testing should be conducted to ensure that the air in the tanks will not endanger the inspectors. The criteria that have to be met can be found in Reference [4.3]:

To get rid of these dangerous gases, continuous forced ventilation should be supplied to the tank during the inspection. An adequate number of deck fans should be used to supply the fresh air.

General tank lighting is provided by air-driven portable lights suspended through deck openings and/or by natural daylight, since all access and tank cleaning holes are opened. Local lighting is provided by the flashlights or cap lights carried by the team members [4.13].

## Access Methods

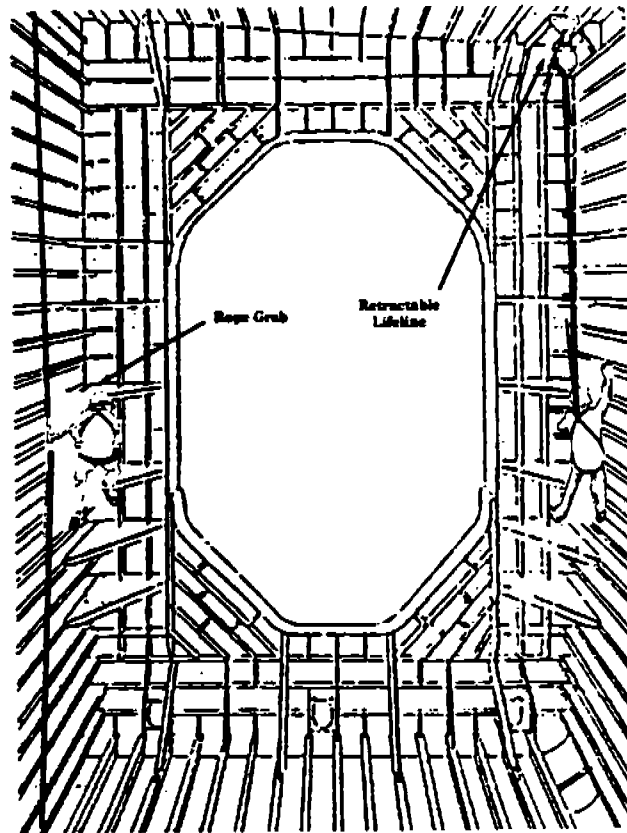
Thirteen inspection access methods are introduced below [4.2]. Each method has its particular advantages and disadvantages. The most popular methods at the present time are "rafting" and "physical climbing", because they are most cost effective. Table 4.5 summarizes the advantages and disadvantages of alternative internal tank structure inspection methods and techniques.

- 1. Improved Tanker design:** Currently most vessels are only fitted with ladders to provide access to the tank bottom. The accessibility to critical structural details like side shell longitudinals is poor. It can be greatly improved by simply adding climbing bars, additional horizontal girders, or catwalks with handrails. Design consideration for accessibility is a future trend. More details are described in the next section "Design Consideration for Accessibility & Ventilation".
- 2. Walking the bottom:** This method is often used as a first step in inspecting the tank. A disadvantage of this method is that the survey is restricted to the lower region of the tank. Despite the disadvantage, it does have the advantage of providing direct access for inspection to the lower flange of the hull girder together with its associated stiffeners.
- 3. Climbing without fall safety device:** The inspectors use the side longitudinals as a ladder to gain access to upper regions of the tank. Most company policies recommend that the climbing height not exceed 3 meters. In fact, a fall at a height of 3 meters or less could cause serious, if not fatal, injury.
- 4. Physical climbing with fall safety device:** The basic concept of this method is to clip a rope to one of the upper side longitudinals and lead it to the bottom of the tank. From the tank bottom the inspector will clip himself onto the rope with a harness attached to his body and a specially designed rope grab clipped to the suspended rope. Should the inspector fall, the rope grab is designed to stop the inspector's descent. This method allows the inspector to inspect the side shell and bulkhead areas, but the under deck area still remains essentially inaccessible. The setup of the fall safety device is difficult also.



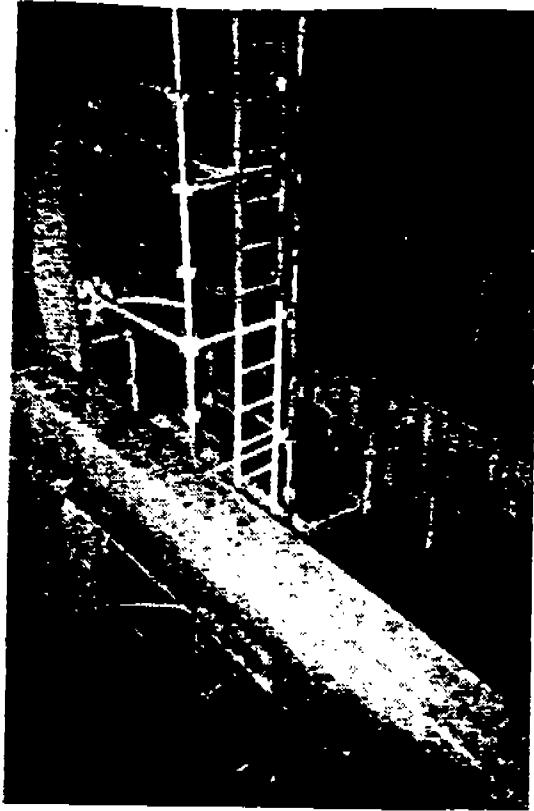


**Figure 4.2: Climbing without fall safety device [4.2]**

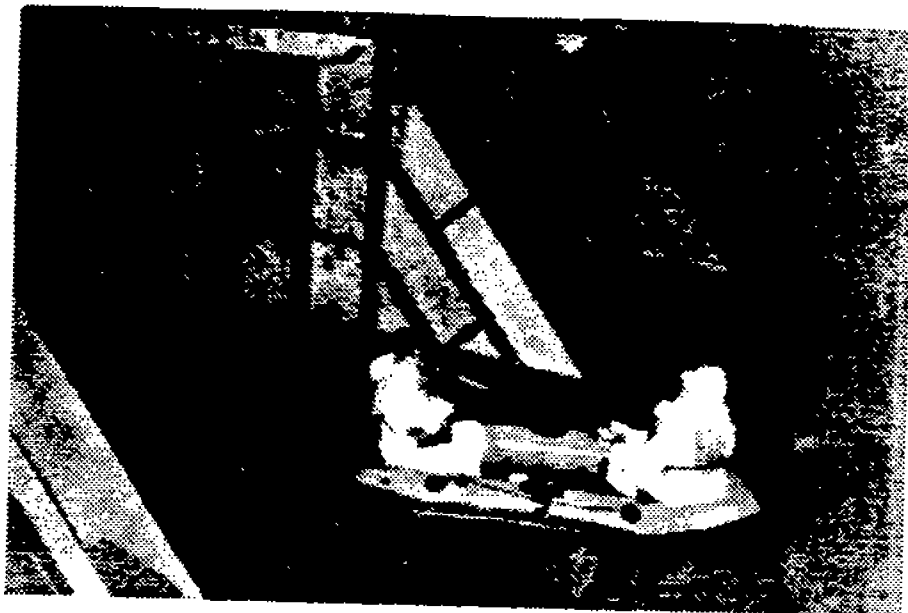


**Figure 4.3: Physical climbing with fall safety device [4.2]**

- 5. Access to side member with ascender:** This is a variation of physical climbing with fall safety devices. The idea is to use an ascender so that the inspector can lower himself down the side of the tank. An ascender is often used in rock climbing when the climber wants to descend down. This method is less physically demanding than climbing with fall safety device and allows the inspector to record information. Some training is required before using this system.
- 6. Fixed Staging:** Fixed staging consists of portable bars and platforms that can be erected inside a tank. Staging allows for the subsequent repairs and the follow-up inspection of the repair work. Fixed staging is one of the preferred methods for the inspectors. With staging, close-up inspection of all parts of the tank by all members of the inspection party is possible. However, the use of staging is limited to the repair yard. Complete staging of all tanks is both cost and time prohibitive.
- 7. Rafting:** Rafting is one of the more common methods used to survey a tank prior to entering the yard. The method consists of usually two inspectors, canvassing the perimeter of a partially ballasted tank in an inflatable rubber raft. An in depth rafting survey can take 15 to 20 days, resulting in considerable out of service costs. If this method will be used, the swash bulkheads and centerline girders of the vessels should have large access openings for raft passage. In addition, access to the deckhead is still limited by the depth of the upper portion of the transverse web frames. Typically, the inspector can find himself a good 15 to 18 feet away from the underdeck structure.
- 8. Binocular with high intensity light:** This method incorporates the use of binoculars or a low powered telescope mounted on a tripod and a high intensity light that is usually powered from a 220V source and is not intrinsically safe. The drawback is that part of the structure is hidden from view.



**Figure 4.4: Fixed Staging [4.2]**



**Figure 4.5: Rafting [4.2]**

- 9. Portable staging:** This method is the state of the art. It uses a portable staging device which works and looks much the same as a window washer device used on tall skyscrapers. The device is easy to disassemble so that access through a manhole is possible. It can usually carry from one to four people. It is air powered. The main difficulty of this method is the initial rigging. If permanent deck plugs are provided in the new construction period, it would greatly improved the rigging efficiency.
- 10. Mechanical arm:** A mechanical arm is a telescoping device that is lowered through a butterworth opening. At the end of the arm is a basket that is capable of carrying an inspector. It is known as the Portable Work Platform or, more commonly, "Ziggy". To assemble Ziggy in the tank, the motor section is first positioned over the opening, through which the vertical sections are then lowered. Vertical movement is controlled from a control panel located at the operator's basket. A back up control station is located on deck. The horizontal beam is shortened or lengthened by means of a hand operated winch. It is designed to be used for repairs, cleaning and inspections.
- 11. Divers:** The use of divers for ship inspections has been successful for underwater hull surveys in lieu of a dry-dock examination. Transferring this method to internal inspections leads to problems due to the turbidity of the water. In addition, this method is unsafe and expensive.
- 12. Remotely operated vehicles (ROV):** ROVs can be used for the inspection of ballasted tanks. The effectiveness of the ROV in the ballasted tank is dependent on water clarity and the cleanliness of the structural surfaces. Utilizing ROVs for tank inspection work is an extremely slow and laborious process. Like rafting, it requires the tank to be ballasted resulting in the owner having to dispose of dirty ballast. In addition, maintaining orientation within the tank can be a challenge. The use of a camera allows close-up inspection by the inspection team on deck. The main advantage of the ROV is that the inspector is out of the tank. Additionally, because the equipment is intrinsically safe, the ROV removes the necessity of the costly tank cleaning and gas freeing procedures.

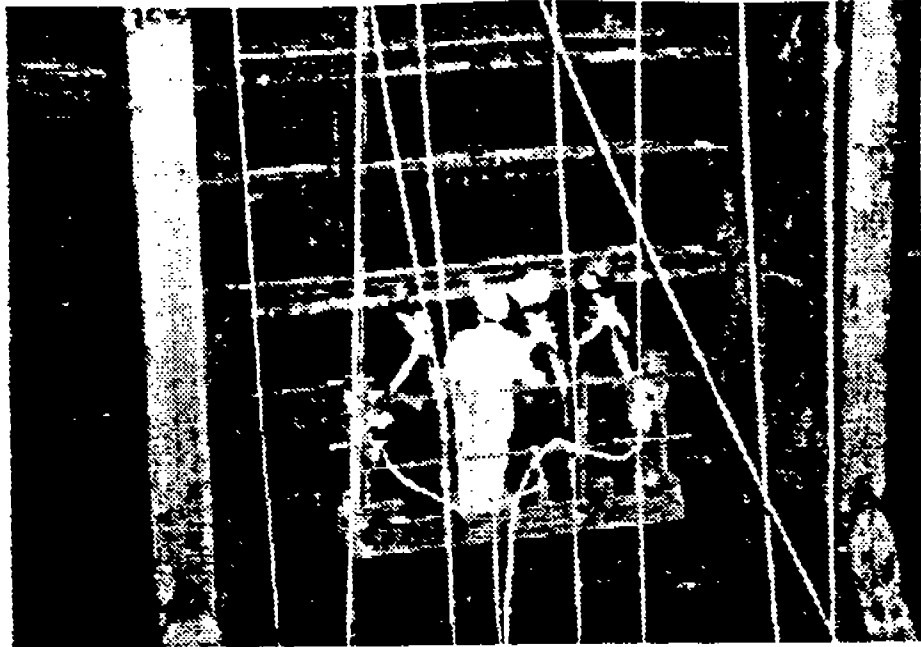


Figure 4.6: Portable staging [4.2]

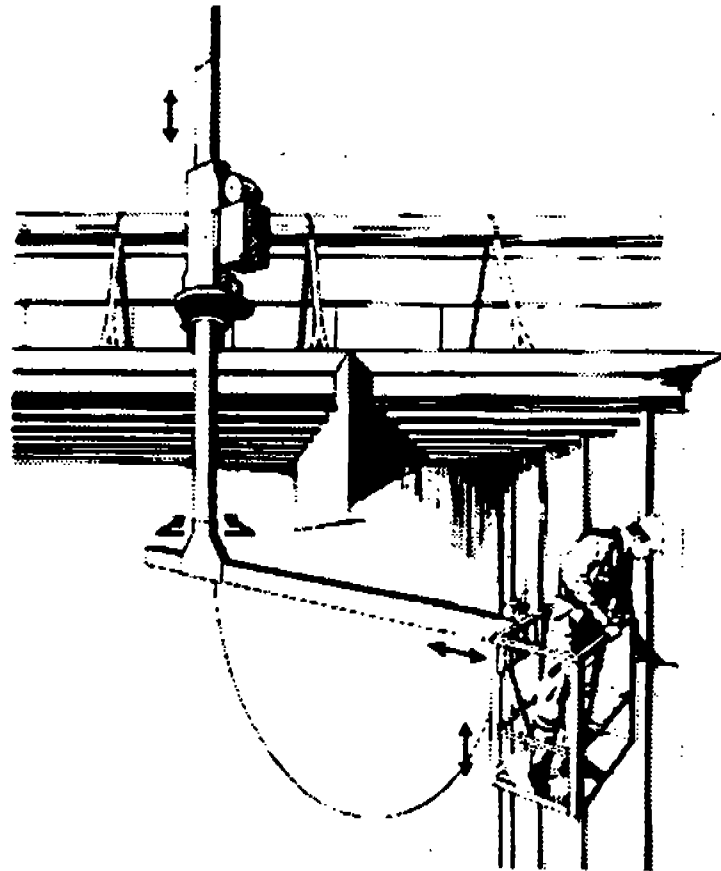


Figure 4.7: Mechanical arm [4.2]

**13. Acoustic emission:** The acoustic emission technique detects the emission of sound from a structural failure. Crack propagation will emit high frequency sound. The placement of several sensors surrounding a source allows the measurement of the sound's arrival time at each sensor, and thereby allows the calculation of the source location. This method is still in the experimental stage.

**Table 4.5: Summary of access methods [4.2]**

Methods	Advantages	Disadvantages
1. Tanker design	Safety, increased accessibility	Cost, weight, maintenance, unwanted structural detail
2. Walking the bottom	Inexpensive	Poor accessibility, only line of sight view
3. Climbing w/o fall safety device	Increased accessibility, inexpensive	Unsafe, impossible to climb central tanks
4. Physical climbing with fall safety device	Increased accessibility, inexpensive	Initial rigging difficult, physically demanding
5. Access to side member with ascender	Increased accessibility, inexpensive	Initial rigging difficult, training required
6. Fixed Staging	Access available to all members in party	Expensive, labor intensive
7. Rafting	Can be accomplished underway, inexpensive	Considered unsafe by some, expensive, time consuming
8. Binocular with high intensity light	Can be accomplished underway	Hands on inspection not possible, only line of sight view
9. Portable staging	Light repairs possible, relatively safe	Expensive, difficult initial rigging
10. Mechanical arm	Increased accessibility	Difficult initial rigging
11. Divers	Can be accomplished underway	Diver inexperienced in ship inspections, time consuming, expensive, unsafe
12. ROV	Can be done underway, gas freeing tank not required if equipment is intrinsically safe	Expensive, easy for operator to become disoriented
13. Acoustic emission	Can be accomplished while vessel is in service provided equipment is intrinsically safe	Only tank top area currently feasible

For the reason of safety, climbing of the side shell longitudinals should be limited to 3 meters above the tank bottom and 6 meters above the water when rafting surveys are conducted [4.2]. Even at 3 meters above the bottom, serious injury could result in the event of a fall. The inspector should never enter a tank alone. Also someone should be standing by on deck with emergency escape equipment during the survey. Heat and humidity can limit in tank inspection time and should be considered prior to the survey.

### **Data Recording Methods**

The inspector's job is to communicate to those outside the tank the condition of the structural members inside the tank. There are at least five ways to do this [4.2].

- (1) Using notepad and pen:** When conducting an internal structural survey, typically the inspector will carry a small pocket size notepad and pen. The defects will be recorded in the notepad and will be reviewed once outside the tank. The inspector records the location, the affected structural member, the type and the size of the defect, and a recommended repair. The inspector will often have to remove one of his/her gloves so that the information can be recorded. The inspector's notepad can be easily stained at this moment. This can make notes difficult to decipher once outside the tank. Rafting poses additional problems; the inspector and all his equipment can become wet. Upon completion of the survey, the inspector is required to transfer the defects list to a smooth form so that repair specifications can be made. However, a lot of people feel a good old fashioned notebook (hard cover) is still the best alternative. A notebook allows the inspector to write and sketch as the situation demands.
- (2) Using small tape recorders:** Using a small tape recorder is easier than writing something on a notepad. The inspector does not need to remove his glove. Besides, he can keep inspecting while recording. However the difficulty lies in transcribing the information. Once the inspector is out of the tank, he still must review the tape and write down the information.
- (3) Having an additional person as the recorder:** This is particularly helpful to the inspector, who can then concentrate on locating defects rather than fumbling with a pen and pad or a tape recorder. The recorder must be familiar with tank

terminology. With the new benzene standards, inspectors are often required to wear a filter half mask in most tanks carrying crude oil or other products containing benzene. This makes communication difficult, so that having an additional recorder may not be a workable alternative.

- (4) **Using a microprocessor-based data collection device:** This method is under experiments and not used broadly yet. The device is similar in size to a hand-held calculator or computer. It will prompt the users as to location, type of defect, and recommended repair. This type of application has been used in other segments of industry. Even some restaurants have used this device for waiters to take customers' orders. The need to transcribe the information when outside the tank would be eliminated. Data recorded in the tank could then be download onto a computer.
- (5) **Using a portable voice data collection device:** This method is under experiments and not used broadly yet. The advantage of this device is similar to the microprocessor-based data collection device. In addition, these speech recognition devices are capable of interpreting the human voice and converting it to machine language. The inspector's hands would be free for other tasks. Once data is collected, it can be downloaded to the computer outside the tanks.

### 4.2.3 Data Analysis

When all the necessary survey data and findings, with respect to overall and local corrosion, fractures, and deformations have been collected, the residual strength of the ship should be evaluated and maintenance needs considered for a further period of operation. If the survey coincides with the Special Periodical Survey for Class, the further period of operation will be considered to be four to five years. The following guidelines about structural integrity also come from Reference [4.3].

**Overall hull girder strength:** The overall hull girder strength should be confirmed on the basis of the actual hull girder section modulus which may be assessed initially using an allowable area at deck and bottom.

**Buckling:** Most buckling found during the survey is important and should be taken as an indication of areas which require stiffening or renewal of material.



Before resorting to adding additional stiffening or cropping and renewing material, it is due, for example, to tug damage (a common occurrence) additional stiffening would not necessarily be in order.

**Fracture:** Any fractures found are normally to be repaired by part renewal of material or by welding. Structural modifications may also be advisable to avoid repetition of fractures.

**General Corrosion:** Once ultrasonic readings are collected and reviewed, the areas of heavy wastage need to be identified. The integrity of corroded local structure may normally be considered by applying a percentage allowance of the thickness supplemented where necessary by the application of buckling criteria (see the following Table). If wastage is in excess of the allowable limit, steel renewal may be needed.

**Local Pitting:** Local corrosion or pitting of the shell can lead to possible hull penetration. Isolated pits are not believed to influence the strength of plates or other structural members. When large areas of structure are affected, however, this will influence the strength and must be considered when assessing the residual mean thickness of material.

The following Table from Reference [4.3] provides guidance to assess wastage data for local strength of structural components. The section modulus for overall strength must also be checked. The criteria in the table are only given for guidance.

**Table 4.6: Criteria of wastage for local strength of structural components**

[4.3]

STRUCTURAL COMPONENT	% CORROSION (1) LOSS INDICATOR		BUCKLING GUIDELINES (LONGITUDINAL FRAMING)	
	A(2)	B(3)	Mild Steel	HTS 36
Deck and bottom plating and longitudinal girders	10	25	s/t = 55 to 60	s/t = 49 to 52
Webs of deck and bottom longitudinals	15	30	h/t = 50 to 65	h/t = 45 to 55
Flat bar longitudinal at deck and bottom (4)	10	25	h/t = 15 to 20	h/t = 15 to 17
Face plates and flanges of longitudinals and longitudinal girders	15	25	b/t = 10	b/t = 10
Side shell	-	20	(5)	
Longitudinal bulkhead plating	15	25	s/t = 70 to 75	s/t = 60 to 79
Webs of side shell and longitudinal bulkhead longitudinals	-	25	(5)	(5)
Transverse bulkhead structure, transverses and side stringers	15	25	(6)	(6)
Remaining secondary structure	-	30	-	-

**Notes**

- (1) Percentages are to be applied to original Rule thicknesses without corrosion allowance reductions for corrosion control notation.
- (2) Column A refers to percent reductions above which further assessment is required.
- (3) Column B refers to percentage reductions where steel renewals may be required.
- (4) The deck and bottom plating and associated longitudinals are to include side and longitudinal bulkhead plating and associated longitudinals within 10% of the depth of ship from the deck and bottom respectively.
- (5) No buckling guidelines are given as the components are not usually limited by this.
- (6) Due to the wide variation in stress levels and stiffening arrangements, no general guidance figure can be given. Individual guidance should be sought from the Classification Society concerned.

**Definitions**

- t = thickness of structure after corrosion.
- s = spacing between longitudinal stiffeners.
- h = web depth of longitudinal stiffeners.
- b = half-breadth of flange for symmetrical sections, and the flange breadth for asymmetrical sections.

102

## **4.3 Design Considerations for Accessibility & Ventilation**

Accessibility and ventilation are two major factors that may increase the safety of the inspectors or repairers. More or less they can be improved through the layout of structure at the design stage.

### **4.3.1 Accessibility**

IACS recommends to provide means to enable the Surveyor to examine the tank structure in a "safe and practical" way, but there are no specific classification rule requirements at present. Therefore, it has become a responsibility for owners who should work with shipbuilders at the time of construction or design stage to develop proper access arrangements for the future inspection and maintenance of tanker structure.

In the past, most new built tankers were designed without carefully considering the accessibility for inspection or maintenance. Some of them were fitted with vertical ladders or other access facilities during the actual construction instead of design process. These tankers, of course, were built with very poor accessibility. Many inspectors or repairers lost their lives or were seriously injured by falling while climbing physically. Until recently, people realized the accessibility should be considered in detail during the design process. Designers could assure proper access when developing the detailed plans by little extra effort. This would help the overall effectiveness of in-service inspection activities.

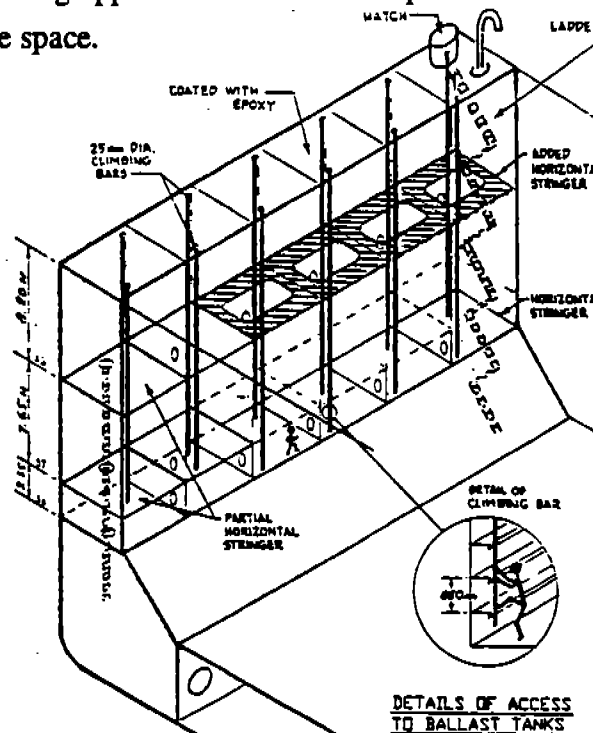
From the view point of cost, the permanent access facilities like vertical ladders only increase the initial cost. They are easy to fit during the new construction and the costs are not high. For the tanker with poor accessibility, staging must be set up for repairs and inspection every time at a significant cost. Over the life of the ship, it could prove to be more economic to have a permanently installed ladder to gain access rather than stage for inspection and repairs.

Improved accessibility should be provided where the probability of structural failure is high. The methods of improving accessibility considered here are listed as follows:

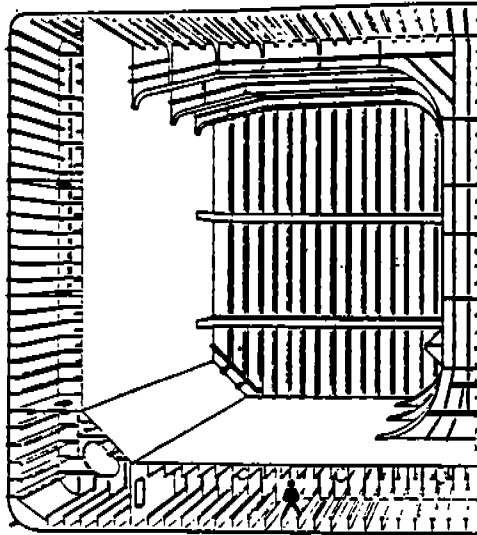
- Install both forward and aft inclined ladders, (i.e. at each end of the tank)
- Fit vertical ladders or climbing bars to the less critical areas,
- Fit permanent walkways,
- Attach permanent clips or lugs on the internal structural members for use of temporary staging or attaching ropes,
- Install extended longitudinals every fourth or fifth longitudinal,
- Provide continuous stringer levels within the side ballast tanks in double hull tankers.

The new tanker is required to be double hull by the Oil Pollution Act of 1990 to reduce the likelihood of spilling oil in the event of grounding. A minimum of 2 meters and maximum of 3 meters is recommended for the height of double bottom and at least width of 2 meters for the vertical wing space.

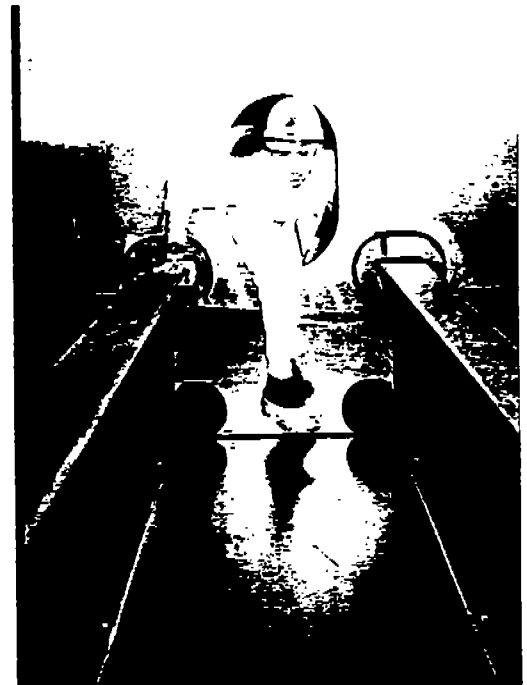
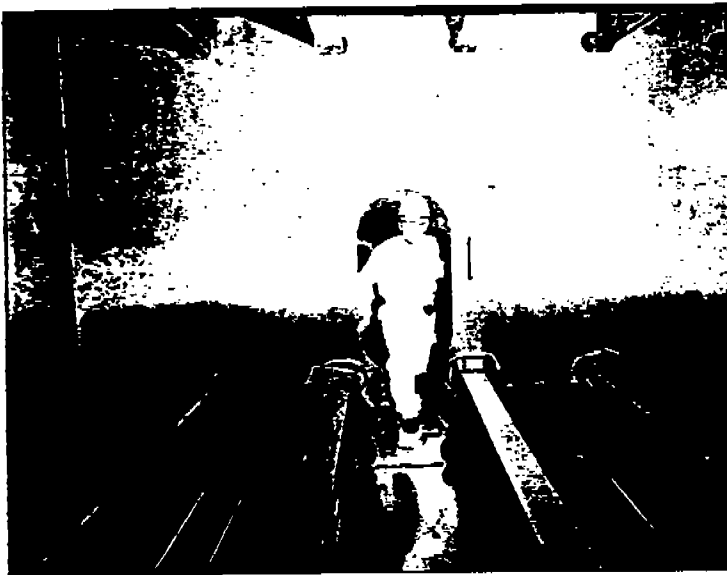
The access openings should be sufficiently large so inspectors can easily pass through (See the following figure). They also must be adequate for people to move through with breathing apparatus on and be adequate to remove an injured person on a stretcher out of the space.



**Figure 4.8: An example showing the arrangement of access facility in a wing tank [4.10]**



**Figure 4.9: A spacious double bottom tank will be easy to inspect [4.10].**



**Figure 4.10: The left picture shows an access opening which is large enough to walk through easily; the right one shows the opening is too small to go through easily [4.10].**

### 4.3.2 Ventilation

The risks of hazardous vapors, suffocation, fire and explosions are controlled by conventional gas freeing, cleaning and ventilating. These operations are more easily and efficiently accomplished if the following factors are addressed at the design stage [4.12].

- The size, number, and location of drain and vent holes in structural elements that, if properly designed, will greatly reduce the amount of deposits.
- The size, number, and location of cleaning guns which can greatly reduce the amount of deposits which cannot be automatically removed.
- The layout of the inert gas piping to ensure that it can be conveniently and easily blanked off.
- The size of all external openings permitting air access to the tank, directly or through ventilation pipes, to provide the maximum fresh air possible for gas purging.

Naval architects that are in charge of layouts and designs of tanker hull structures need to have direct personal experience in the inspections. This experience provides important insights into how hull structure might be configured to improve the quality, safety, and efficiency of inspections.

## 4.4 Structural Monitoring

In the past, assessment of the structural damage potential during a voyage depended primarily on the judgment of the navigating officer. Such judgement was typically based on the individual officer's personal experience which may or may not have been comprehensive enough to allow an objective decision to be made. Therefore, in the past twenty-five years, various government agencies and private organizations have carried out projects where ship responses in heavy weather were monitored and displayed. Although most of these were research projects, over the years the concept of displaying these measurements for use by the navigating officer has been recognized as a mean to improve operations and minimize damage in heavy weather [4.14]. A Ship Response Monitor (SRM) will provide sufficient information to assist ships' officers accessing structural damage potential due to undesirable dynamic wave loads.

### 4.4.1 Applications

SRMs typically provide ship motions or hull stress data on a near real-time basis to permit the navigating officer to assess the severity of the environment and the way the ship is responding to that environment. To date, the idea has not yet widely adapted by industry and the hardware has not been commercialized to the point where standard equipment is available. Only a few vessels have SRM installed on board.

Typical types of structural damage sustained by ships due to wave-induced motions include [4.14]:

- Bottom slamming
- Flare immersion impact (or slamming)
- Damage due to shipping water
- Cargo shifting
- Damage due to fluid sloshing
- Damage due to hull girder bending (infrequent)

In most of the above cases, the motions or accelerations which cause damage can be controlled through changes in speed and/or heading relative to the wave directions. Shipping additional ballast to attain a deeper draft can also help minimize the ship's response to seaway-induced loads. These actions must, however, be traded off against their cost due to increased voyage time and fuel. A SRM should accurately measure some aspect of ship response and display this information in a form that can be easily understood. The navigating officer can then use the information in conjunction with other observations to decide the appropriate course of action.

A representative listing of measurements can include:

- Bow accelerations
- Mid-ship biaxial accelerations
- Aft lateral accelerations
- Pressure gage at bow
- Midship deck stresses
- Longitudinal Bending Moment stresses

- Speed and heading
- Roll and pitch (period and angle)

A SRM system can not only be used to provide guidance for ship handling. But also, the system turns out to be an effective tool for the owner to access the structural analysis through the continuous recording of data. For example, by using the data we can compute the fatigue damage factor and then estimate the fatigue life of the censored structural detail.

#### 4.4.2 Systems

A SRM system consists of a central unit installed on the bridge, an array of sensors located in locations where we want to collect information, and cables for connecting the central unit with the sensors. A typical four-sensor installation is shown in the following Figure.

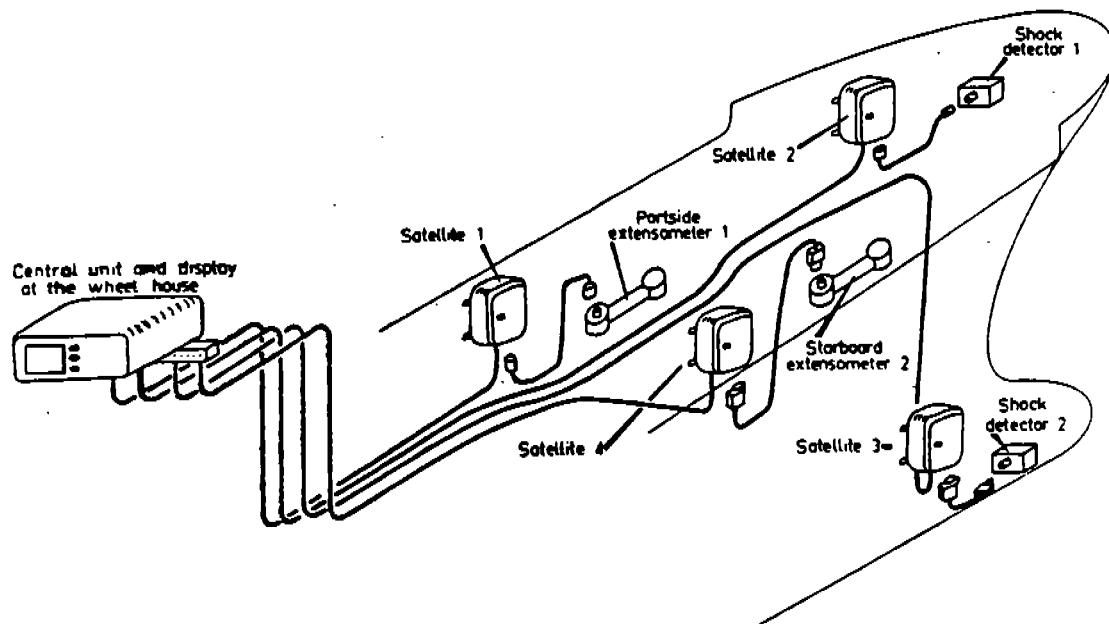
The function of the central unit is to display and store the data collected by the sensors. Specialized data analysis software need to be developed to manage the large volumes of data being received. Trend displays are fitted for on-board guidance of exceedance of design strength criteria. Display of data such as bending moment plotted against time provides on-line guidance of trends of variation against an upper design limit. The design limit is set initially at the rule design still water and wave stress, but will be adjusted following structural analysis and as corrosion data becomes available for the ship. The sensors are used to obtain data which could be acceleration or bending stresses.

In Reference [4.14], a standardized SRM is developed. It recommends that a standardized SRM consist of two standard sensors, several user-selectable sensors, necessary signal conditioning and displays for presenting the information to ship's personnel. The provision of several user-selectable sensors will permit configurations of the system for different ship types and operating company preferences.

The SRM discussed here is simply a response monitor and does not provide any guidance to navigating officers. A further developed SRM would include the capability to provide guidance on the effects of actions intended to reduce wave response. For example, if a course or speed change is contemplated, the navigating officer would be



provided with data on the probable effects, and he could use the information to decide a course of action. An additional future enhancement for SRM could be the capability of giving recommendations on the optimum actions that should be taken. These recommendations would attempt to keep wave response within an acceptable level while at the same time minimizing the loss of speed and fuel consumption.



**Figure 4.11: An example of installation of ship response monitor [4.15]**

The SRM needs to be reliable and easy to maintain. Should the system fail, the incorrect information could lead the navigating officer to a wrong decision. Therefore, even if failures occur, they should not result in the display of erroneous data, and the system should provide an indication of the extent of the failure and validity of remaining displays.

References:

- [4.1] Robert G. Bea, "Marine Structural Integrity Programs", Ship Structure Committee Report No. 365, 1992.
- [4.2] Robert S. Holzman, Lt., USCG, "Advancements In Tankship Internal Structural Inspection Techniques", Dept. of Naval Architecture, Univ. of California, Berkeley, 1992
- [4.3] Tanker Structure Co-operative Forum, "Guidance Manual for the Inspection and Condition Assessment of Tanker Structures", International Chamber of Shipping Oil Companies International Marine Forum, Witherby & Co. Ltd., London, 1986.
- [4.4] Tanker Structure Cooperative Forum, "Guidelines for the Inspection and Maintenance of New Generation Double Hull Structures", 1990.
- [4.5] Knut T. Skaar, Det norske Veritas Classification A/S, Norway, "Future Class Requirements and Support Services for Inspection and Maintenance", 1991
- [4.6] Nedret S. Basar, Victor W. Jovina, "Planning and Conduction Improved Ship Structural Inspections", SNAME report, Spring Meeting/STAR Symposium, 1986
- [4.7] J. D. Sipes, et al., "Trans-Alaska Pipeline Service (TAPS) Tanker Structural Failure Study", U. S. Coast Guard, 1990.
- [4.8] Office of Marine Safety, "Trans-Alaska Pipeline Service (TAPS) Tanker Structural Failure Study - Follow Up Report", U. S. Coast Guard, 1990.
- [4.9] CFTO, "Requirements for Survey and Repair of Steel HMC Ships"
- [4.10] John W. Kimble, Chevron Shipping, "Design of Tankers for the 90's", 1992.
- [4.11] Frederick H. Kristers, and Frank W. Kearney, Evaluation of Civil Works Metal Structures", 1991.
- [4.12] Tanker Structure Cooperative Forum, "Inspection Procedure and their influence on Tanker Design", Presentation by Bureau Veritas/Exxon, TSCF meeting with shipbuilders, 1987.
- [4.13] Peter F. Weber, Institute of Marine Engineers, "Structural Surveys of Oil Tankers", Joint Meeting with the Royal Institution of Naval Architects, 1984
- [4.14] DeBord, Jr., FW, Hennessy, B, Offshore Technology Corporation, "Development of a Generalized Onboard Response Monitoring System - Phase I", Ship Structure Committee, Report No. SSC-349, 1990.
- [4.15] M. Huther and J. C. Le Hire, Bureau Veritas, Research and Development Centre, France, "SAFENAV, a Ship Behaviour Monitoring System".
- [4.16] Tanker Structure Cooperative Forum, "Condition Evaluation and Maintenance of Tanker Structure", 1992.
- [4.17] American Welding Society Inc., "Guide for Steel Hull Welding", 1984

# Chapter 5 Maintenance and Repair

## **5.0 Introduction**

### **5.0.1 Objectives of Maintenance and Repairs**

The basic objective of structural maintenance is to prevent unwarranted degradation in the strength and serviceability of the hull structure. Structural maintenance is directed primarily at preventing excessive corrosion through the maintenance of coatings and cathode protection systems. Preservation of coatings in the coated ballast spaces is the primary line of defense in corrosion protection. Another objective of structural maintenance is to preserve the integrity of the structure through judicious renewals of steel and repairs to damaged elements [5.1].

### **5.0.2 Maintenance and Repair Programs**

To maintain the tanker in a sound structural condition, there are two types of repairs to be considered: mandatory repairs and voluntary repairs. The first is mandatory repairs, in which ship owners carry out steel repair to meet the minimum requirements imposed by the classification societies and the flag administration. From the long-term economic view, the mandatory repairs are often not enough. Ship owners may carry out additional voluntary repairs to minimize the total maintenance cost for the intended remaining "life continuance". The voluntary repairs are focused on the following three activities: maintaining the effectiveness of corrosion control system, maintaining the steel thickness above wastage limit, improving the design of structural details by modification.

In brief, the strategy of maintenance and repair is mainly based on the design life of the vessel or the future plans of company for retention of the ship. The optimum repair and maintenance strategy can be developed by combining various repair methods under the following constraints and considerations [5.3]:

- Maintain the structural soundness and environmental protection within the intended remaining life.
- Maintain the effectiveness of corrosion control system.
- Meet the Flag Administration and Classification Societies' requirements.
- Provide the most cost effective and least out-of-service time for repairs.

Ideally, several months before the vessel is scheduled for the repair yard, an initial visual and gauging survey will be conducted to evaluate the effectiveness of corrosion protection system and quantify the degree and extent of steel wastage. Based on the results of the survey, a repair plan can be developed. Once the ship enters the shipyard, extensive visual and gauging surveys are again conducted to identify and verify the steel condition in details. These secondary surveys usually reveal additional repair items.

For the ships that have less than 5 year life continuance, carrying out all mandatory repairs are sufficient and cost effective. However if the expected life continuances are more than 5 years, the repair and maintenance program should emphasize "preventive" maintenance measures. The following measures are recommended [5.3]:

1. Maintenance of corrosion control systems
  - Develop and implement a just-in-time coating program for the un-coated area before the steel reaching the wastage limit.
  - Develop and implement a just-in-time re-coating program for the coating areas.
  - Develop and implement an effective sacrificial anode installation and replacement program.
2. Implement timely design modification if required.
3. Implement a continuous structural inspection and surveillance program.

The repair of critical internal structural details is a difficult and demanding task for ship owners. There is no reasonable consensus on what, how, and when to repair. The general lack of readily retrievable and analyzable information on repairs and maintenance frustrates repair and maintenance tracking. Many fracture repairs appear to be ineffectual. Veeing and welding cracks that have occurred early in the life of the ship seems to be ineffective; they quickly develop again. If one replaces the cracked plate and

modify design by adding a bracket, a lug, or etc., the repair can usually last longer than veeing and welding. However, this repair may not be cost effective if the ship will be scrapped in the near future.

## **5.1 Steel Repairs**

Repair of cracks vary widely. Repairs of cracks can range from temporary cold patches to stop leaks to complete re-design of the structural detail and replacement of steel nearby the detail. Welding cracks is a popular repair, but it frequently failed again within a short time. Drilling the ends of the cracks is a frequently used temporary repair measure that is used until the ship can be taken into the dry-dock. Repairs of these cracks can range from simple welding to addition of reinforcing elements. Experience indicates that many of these repairs must be repeated in subsequent dry docking. In one case, a series of side shell longitudinal crack has been repaired four times, and each time a different repair procedure has been tried [5.1].

Three types of steel repairs will be introduced in the following paragraphs. They are steel renewal, steel reinforcement, and crack repair.

### **5.1.1 Steel Renewal**

Available repair strategies for steel renewal are:

- **Replacement in kind with the original scantling.**
- **Replacement by less than original scantling plus additional reinforcement to restore structure to the equivalent original strength in bending, shear force, buckling and fatigue.**

In the event of steel renewals being required to compensate for either local wastage or structural integrity, according to the following acceptance criteria in Table 5.1 [5.4], it is important that the extent of this new material is sufficient to maintain structural continuity and avoid any potential discontinuities [5.3].

From the repair point of view, the replacement of complete panels of structure may prove most cost effective and ultimately more reliable, than merely renewing

individual members especially if a longer life span has been projected for the vessel. For instance, in the case of the removal and re-welding of bulkhead stiffening to bulkhead plating, the chances of penetrations of the remaining corroded plating is usually very high and the future watertight integrity of this division remains in-question. Also, the combination of steel renewal and coating could be the most cost effective method for a longer life span.

Table 5.1: Criteria of wastage for local strength of structural components [5.4]

STRUCTURAL COMPONENT	% CORROSION (1) LOSS INDICATOR		BUCKLING GUIDELINES (LONGITUDINAL FRAMING)	
	A(2)	B(3)	Mild Steel	HTS 36
Deck and bottom plating and longitudinal girders	10	25	s/t = 55 to 60	s/t = 49 to 52
Webs of deck and bottom longitudinals	15	30	h/t = 50 to 65	h/t = 45 to 55
Flat bar longitudinal at deck and bottom (4)	10	25	h/t = 15 to 20	h/t = 15 to 17
Face plates and flanges of longitudinals and longitudinal girders	15	25	b/t = 10	b/t = 10
Side shell	-	20	(5)	
Longitudinal bulkhead plating	15	25	s/t = 70 to 75	s/t = 60 to 79
Webs of side shell and longitudinal bulkhead longitudinals	-	25	(5)	(5)
Transverse bulkhead structure, transverses and side stringers	15	25	(6)	(6)
Remaining secondary structure	-	30	-	-

Notes

- (1) Percentages are to be applied to original Rule thicknesses without corrosion allowance reductions for corrosion control notation.
- (2) Column A refers to percent reductions above which further assessment is required.
- (3) Column B refers to percentage reductions where steel renewals may be required.
- (4) The deck and bottom plating and associated longitudinals are to include side and longitudinal bulkhead plating and associated longitudinals within 10% of the depth of ship from the deck and bottom respectively.
- (5) No buckling guidelines are given as the components are not usually limited by this.
- (6) Due to the wide variation in stress levels and stiffening arrangements, no general guidance figure can be given. Individual guidance should be sought from the Classification Society concerned.

Definitions

- t = thickness of structure after corrosion.
- s = spacing between longitudinal stiffeners.
- h = web depth of longitudinal stiffeners.
- b = half-breadth of flange for symmetrical sections, and the flange breadth for asymmetrical sections.

114

### 5.1.2 Steel Reinforcement

Available repair strategies for steel reinforcement are:

- **Installation of doubler plate.**
- **Installation of intermediate stiffeners to restore to the equivalent original strength.**

In some cases generally corroded areas of tank structure are found to be below the minimum section modulus requirements. It may be possible, at the discretion of the relevant Classification Society, to install additional steelworks in conjunction with an effective corrosion protection system (painting), rather than carry out extensive steel renewals. This form of repair should aim at re-establishing the required minimum section modulus of the overall defective areas, while dealing directly with local defects or fractures as found necessary. Regular re-inspection of this alternative reinforcement should be carried out to ensure its continued effectiveness in maintaining the overall structure integrity of the vessel [5.3].

### 5.1.3 Crack Repair

Available strategies for crack repair are:

- **Re-weld the cracks or fractures to the original construction.**
- **Replace the cracking plate.**
- **Modify design by adding bracket, stiffener, lug, or collar plate.**
- **Change configuration by applying soft toe, increasing radius, trimming face plate, enlarging drain holes, etc.**
- **Enhance scantling in size or thickness.**

Cracks are potentially the most serious of defects as they can grow rapidly in size leaving affected structure unable to bear loads. As a result, the surrounding structure must carry a greater loading that can in turn lead to its failure in the future. If this process continues unchecked, hull girder or long large panels of side shell collapse can result.

Cracks in primary structure (the structure which contributes significantly to the main structural strength of the ship such as hull plates, stiffeners, principal decks, main transverses, and so on) may be temporarily repaired by fitting double plates or gouging out the crack and filling in with weld metal. Gouging and re-welding is an easy and common way of repair. However, the strength of re-welding cracks is, almost invariably, worse than the original one. The repaired weld will create new crack potentials and thus fail even earlier. The better way of repair is to modify the local geometry to reduce the stress concentration. Such repairs are sometimes considered in attempting to get the ship to a facility where full repairs can be made. If a longer life continuance is expected for the ship, a more robust repair such as design modification should be considered.

In the other hands, cracks in secondary structure (the structure which neither contributes to the structural strength nor the watertight integrity such as partition bulkheads, platforms and so on) may be arrested temporarily by drilling a hole of diameter equal to the plate thickness at a distance of two plate thicknesses in front of the visible crack tip and on a line with the direction of anticipated crack propagation [5.8].

It is difficult to decide which repair method is most reliable and cost effective for a particular crack. The following Figure shows the variety of repair methods of a particular crack in way of longitudinal cutout. The selection of different repair alternatives is usually depended on the location of the crack and the expected life continuance of the ship.

A catalogue of structural detail crack failures has been created in "Guidance Manual for the Inspection and Condition Assessment of Tanker Structures" by the Tanker Structure Cooperative Forum. Information on the experiences of structural detail failures was supplied by the Forum members. Approximately 210 sketches are gathered. On each type of structural detail failure, the catalogue includes a sketch illustrating the failure, a sketch illustrating the proposed repair, a list of factors contributing to the failure, and other information. Two cases of the catalogue are showed on the following pages. For more cases, refer to Reference [5.4].



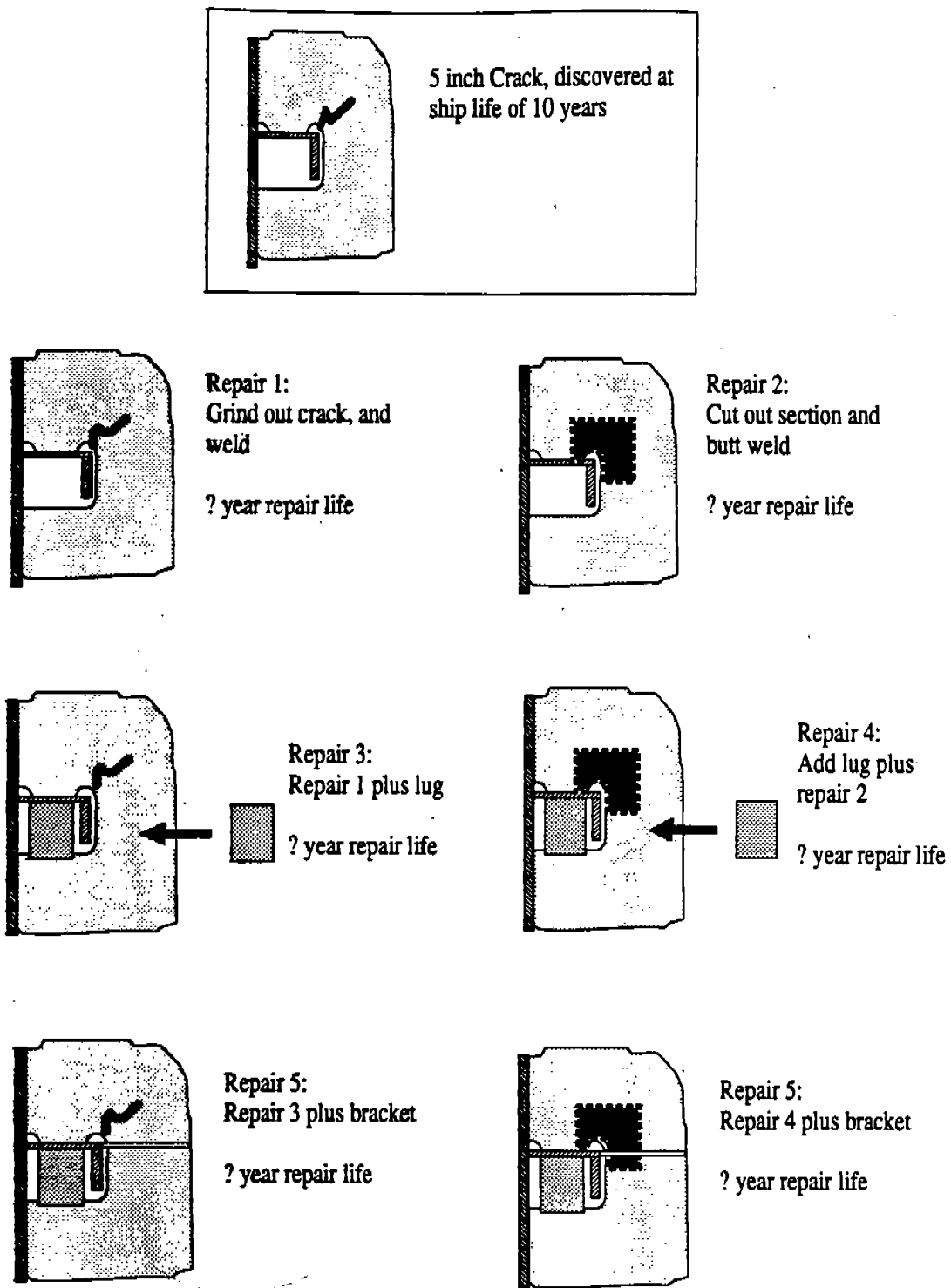


Figure 5.1: Repair alternatives example [5.2]

<p><b>LOCATION:</b> Connection of longitudinals to transverse webs</p> <p><b>EXAMPLE No. 1:</b> Web and flat bar fractures at cut-outs for longitudinal stiffener connections</p>	
<p><b>TYPICAL DAMAGE</b></p>	<p><b>PROPOSED REPAIR</b></p>
<p>SHELL PLATING OR LONGITUDINAL BULKHEAD</p> <p>FLAT BAR STIFFENER</p> <p>FRACTURED WELD WEB</p> <p>FRACTURE</p> <p>VIEW A - A</p> <p>SIDE SHELL OR BULKHEAD LONGITUDINAL WEB PLATING</p> <p>WEB FLAT BAR STIFFENER</p> <p>FRACTURE</p> <p>NOTE - ONE OR MORE FRACTURES MAY OCCUR</p>	<p>FULL COLLAR IF FRACTURES IN WEB PLATE ARE SMALL AND ARE REPAIRED BY WELDING</p> <p>LUG</p> <p>BACKING BRACKET</p> <p>LUG</p> <p>VIEW A - A</p> <p>WEB AND FLAT BAR CROPPED AND PART RENEWED OR ALTERNATIVELY WELDED</p>
<p><b>FACTORS CONTRIBUTING TO DAMAGE</b></p> <ol style="list-style-type: none"> <li>1. Asymmetrical connection of flat bar stiffener resulting in high peak stresses at the heel of the stiffener under fatigue loading.</li> <li>2. Insufficient area of connection of longitudinal to web plate.</li> <li>3. Defective weld at return around the plate thickness.</li> <li>4. High localised corrosion at areas of stress concentration such as flat bar stiffener connections, corners of cut-out for the longitudinal and connection of web to shell at cut-outs.</li> <li>5. High shear stress in the web of the transverse.</li> <li>6. Dynamic sea way loads/ship motions.</li> </ol>	
<p><b>TANKER STRUCTURE CO-OPERATIVE FORUM</b></p> <p><b>SUBJECT: CATALOGUE OF STRUCTURAL DETAILS</b></p>	

Figure 5.2: Repair example at the connection of longitudinals to transverse webs [5.4]

<b>LOCATION:</b> Connection of longitudinals to plane transverse bulkheads		<b>GROUP No. 2</b>
<b>EXAMPLE No. 1:</b> Fractured side shell longitudinal. Bulkhead horizontally stiffened		
<b>TYPICAL DAMAGE</b>		<b>PROPOSED REPAIR</b>
<b>FACTORS CONTRIBUTING TO DAMAGE</b> <ol style="list-style-type: none"> <li>1. Asymmetrical connection of bracket in association with a backing bracket which is too small. This results in high stress at the toe of the smaller bracket under fatigue loading.</li> <li>2. Higher tensile steel longitudinal resulting in greater stresses.</li> <li>3. Fabricated longitudinal having the face plate attached to the underside of the web (where fitted) and with welding onto the exposed edge of the web. This results in poor fatigue strength of the connection of the longitudinal web to the bracket.</li> <li>4. Horizontally stiffened transverse bulkhead causing increased end moments at the side shell longitudinal connection resulting from loading on the transverse bulkhead.</li> <li>5. Deflection of the adjacent side shell transverse under load.</li> <li>6. Defective weld at return around the plate thickness.</li> <li>7. Dynamic sea way loads ship motions.</li> </ol>		
<b>TANKER STRUCTURE CO-OPERATIVE FORUM</b>		
<b>SUBJECT: CATALOGUE OF STRUCTURAL DETAILS</b>		

Figure 5.3: Repair example at the connection of longitudinals to plane transverse bulkheads [5.4]

119

## **5.2 Maintenance of Corrosion Control Systems**

The most critical structural problem found on aging vessels having suffered from lack of long term preventive maintenance is severe corrosion of hull structures, particularly in permanent ballast tanks. Such tanks are normally provided with coating at the new building stage. If not properly maintained, this coating will normally break down and lose its preventive effects after 5 to 10 years. Thereafter an increased rate of corrosion will be experienced. At the time when such vessels come up for their third special periodical survey (12-15 years of age) it will normally be necessary to renew significant amounts of steel mainly in the form of internal structures [5.9]. To prevent expensive steel renewing, coating should be maintained constantly.

The following paragraphs will introduce the coating maintenance of general corrosion and pitting/grooving as well as the maintenance of sacrificial anodes.

### **5.2.1 General Corrosion**

Available maintenance strategies for controlling general corrosion are:

- **Blast and coat/re-coat by hard coating.**
- **Apply soft coating to coating breakdown areas.**
- **Add new anodes for needed protection areas.**

By means of maintaining the coating, the hull structure may last for 25 years and beyond without the need for steel renewals, even in permanent ballast tanks. On the other hand without maintaining the corrosion protection system, the need for significant steel renewals will normally start at around 15 years of age [5.9]. Since steel renewals are expensive, the coating repair is critical for owners. By deferring coating repairs, the owner risks steel renewals at the next overhaul. Roughly speaking, the cost to coat plating is equal to the cost of renewing 10% of the same plate assuming a thickness of 12 mm [5.5]. Besides, steel work in an existing structure introduces new problems such as residual stresses and possible weld defects. Thus, if corrosion has result in critical coating breakdown, such tanks are recommended to be blasted and re-coated timely.

From both visual and gauging information of a survey, decisions can be taken regarding life continuance and to the extent of maintenance necessary to reinstate the corrosion protection system. In the case of long-term (8 to 10 years) operations, re-coating of the breakdown areas (or more usually the entire tank) would be regarded as a cost effective solution instead of any potential steel renewals. For shorter-term (4 to 5 years) operations, temporary protection systems such as soft coatings or sacrificial anodes may be considered. The effective life of soft coatings is usually restricted to about 2 to 4 years only, for this reason this protection system should really be regarded as temporary and should be subjected to more regular and comprehensive thickness gauging and close-up surveys than that considered for hard coatings [5.3].

After choosing the coating system, surface preparation is followed. Several methods can be used for cleaning the ship's hull before re-coating, if hard coatings are chosen. Power disk grinding or wire brushing uses either an electrically or pneumatically driven machine which is hand held. The method is slow but provides a relatively good finish. High pressure water jetting is another method which is being increasingly used for hull cleaning. Water at pressure of 150-500 bar is directed on to the hull by a tubular steel lance. The higher pressure can clean the hull down to the bare metal. The results from this method are excellent and very fast, although time is lost while waiting for the hull to dry. It is, however, a skilled operation requiring competent trained personnel for efficient safe performance. Another method used widely is shot-blasting. It uses a jet of abrasive at 5-7 bar pressure fired from a nozzle on to the ship's hull. This method rapidly produces a clean dry surface ready for painting. The dusty, dirty nature of the work stops any other activities in the area. Hydro blasting is less expensive and less disruptive to other repair work on the vessel. However the expected life of the coating after hydro blasting is less than that after dry blasting. Hydro blasting is a relatively new technique and shipyards are not always equipped for large capacity hydro blasting [5.5].

After surface preparation, paint application begins. The principal methods of paint application are the airless spray, the air-assisted spray, the roller and the brush. Brush and roller application is employed where rough surfaces exist and small often inaccessible areas are to be covered. The method is slow, labor intensive and difficult with certain types of paints. Air-assisted spraying has been largely replaced by the airless spray technique for which most modern paints are formulated. Airless spray is the fastest and cleanest application method. High build materials are suitable for this method of application with dry film thicknesses up to 300  $\mu$ m possible in one application.

For consistent assessments of the degree of effectiveness of an existing surface coating system, a convenient rating is devised by Reference [5.3] as the follows. Figure 5.4 shows an assessment scale for breakdown of coatings.

1. **GOOD** condition with only minor spot rusting.
2. **FAIR** condition with light rusting.
3. **FAIR** condition with local breakdown at edges of stiffeners and weld connections plus light rusting.
4. **POOR** condition with general breakdown between 10%-60% area.
5. **COMPLETE** breakdown over 60% area.

### 5.2.2 Pitting and Grooving

Available maintenance strategies for controlling pitting and grooving are:

- **Welding only.**
- **Welding plus hard coating.**
- **Coating by pit filling compound of hard coating.**
- **Installing zinc anodes.**

Pitting mainly can be found on the internal horizontal surface, particularly in the bottom plate of the cargo or ballast tanks. If widely scattered, they may not affect the general strength of the vessel. However due to their depth and quick deterioration rate, they may quickly lead to a through penetration with subsequent pollution danger. Using the corrosion rate of about 1 to 3 mm per year for pitting/grooving and the period to next overhaul, a defined thickness can be established for the decision of pitting repair. For examples, if the period to next overhaul is 5 years, the pits can grow about 15 mm deeper during these 5 years. To prevent pollution or water tight problems, the defined depth should be set as 15 mm at least in this case. The repairs of different levels of pittings are introduced as follows:

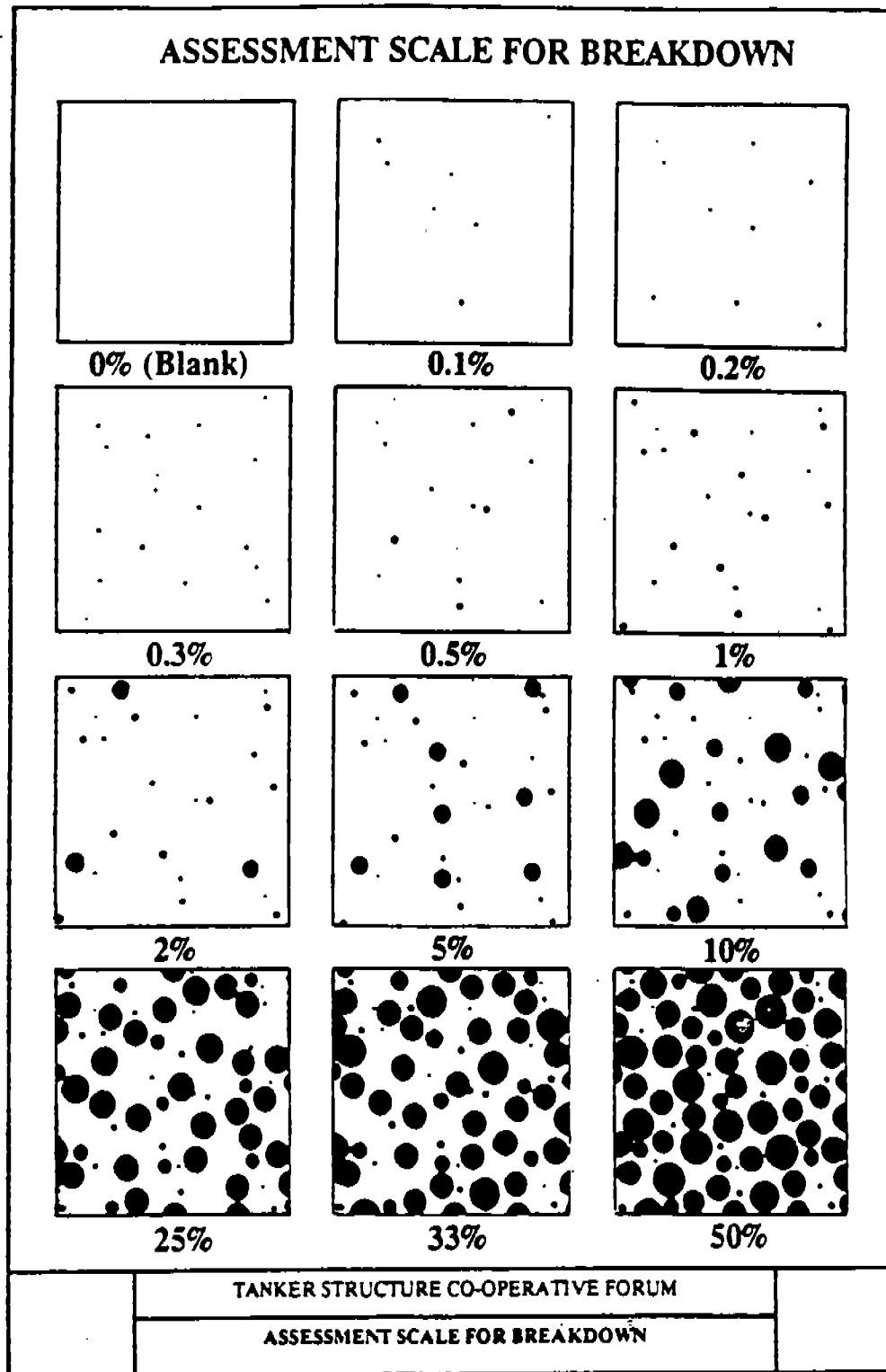


Figure 5.4: Assessment scale for breakdown [5.3]

- (a) **Remaining plate thickness more than the defined thickness:** Pitted area should be cleaned with thinner grit blasted to SA 2.5 and then brush coated with two coats of coal tar epoxy to 250 micron thickness or to be vacuum blasted and filled with pourable pit filler. If brush coating is used, any sharp edges at the top of the pit should be ground away before re-coating. Special care should be taken in the perfect cleaning of the pit with thinner before application of the coating as any oil residue can impair the adhesion of the coating. Cleanness is so important that even blasting is not recommended as the abrasive material gets contaminated with oil after few times of use. The following Figure shows correct and wrong applications.

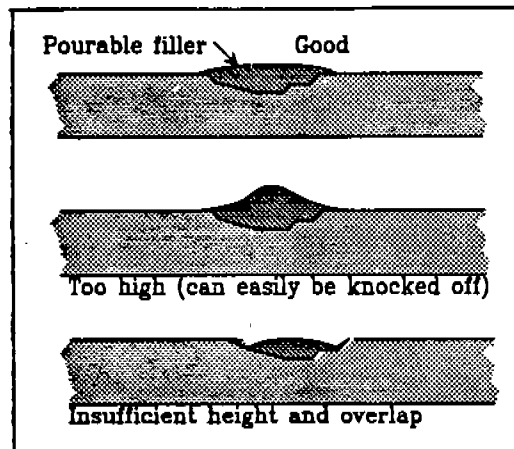


Figure 5.5: Application of pourable filler in pittings.

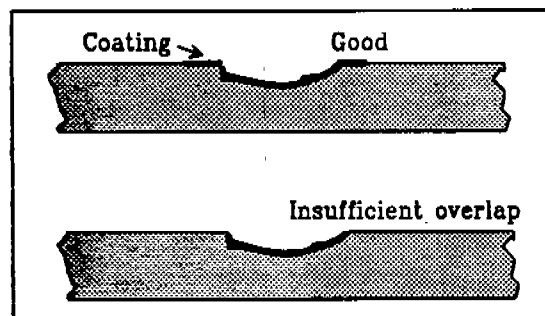


Figure 5.6: Application of coating in pittings.

- (b) **Remaining thickness between the defined thickness and 6 mm:** This type of pitting can be welded up afloat or in dry-dock subject to the following conditions being observed.



1. Maximum diameter of pit 200 mm,
2. Distance between pits not less than one half diameter of the larger pit,
3. Grade of steel E or EH excluded afloat (This is due to the thermal treatment of these Grades which will not be maintained after welding afloat).
4. Sea water temperature not less than 4 degree C.

To prevent burn-through and to reduce risk of post-weld cracking, pits having less than 6 mm remaining plate thickness cannot be clad welded afloat. Repairs to these pits must be deferred until vessel is dry-docked. After repairs, a dye-check examination must be made of the dry-dock side of each deep pit and X-rays taken as determined.

- (c) **Any conditions other than (a) and (b):** For pits with a depth, diameter, distribution or shape which is not in conformity with (a) and (b), above welding cannot be carried out. There are two available repair alternatives. The first is to crop and renew the plating. Another is to use spigot plate with diameter less than 300 mm. Both repairs should be X-rayed after repairs.

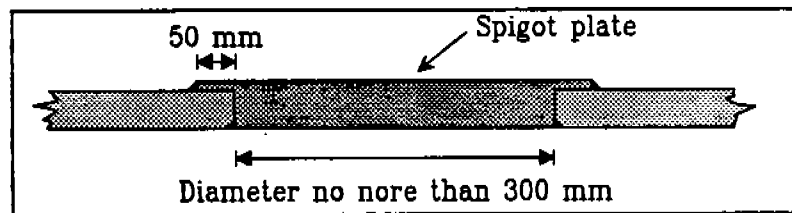


Figure 5.7: Spigot plate

Grooving of structural members is another form of local corrosion which takes place usually next to weld connections and is related to flexing of the stiffened panel or areas of regular erosion. Epoxy coating of the affected areas and additional stiffening of the relevant panels is regarded as the best way of this problem [5.3].

### 5.2.3 Sacrificial Anodes

Available maintenance strategies for sacrificial anodes are:

- Replace the existing anodes.
- Add new anodes for needed protection areas.

125

Normal design basis for anode life is 4 to 5 years, corresponding to replacement every other repair period [5.7]. Anode protection systems require very little maintenance during their lives. Studies have shown anodes to be self cleaning in most instances. However, any anodes showing extreme persistent coatings of oil or sludge should be cleaned. In addition, anodes may be covered with a white, flaky product. This substance is made up of the products of corrosion of the anode and can be taken as a sign that the anodes are working to protect the structure. If the anode alloy conforms to MIL-A-18001H and the corrosion product is not extremely thick, the product does not cause serious reductions in anode effectiveness. Cleaning is not necessary unless the buildup is extreme (has been observed at up to 6 inches thick) or when anode wastage must be determined. Also, cleaning is required if the corrosion product is particularly dense and tightly adhering, especially if it appears that the anode is not being consumed. In this case the corrosion product may be a result of excessive impurities in the anode.

Anode wastage should be monitored when possible. In most cases, anodes should be replaced before they are completely wasted. The system is usually designed with an effective anode radius at 60% consumption [5.7]. As the radius decreases, the anode resistance increases. This means that if most of the anodes are more than 60% radius wasted, the system may not be providing adequate protection for the structure, and anode replacement should be considered. In the other way, the anodes at over 80% consumption of weight are suggested to be replaced by reference [5.4].

References:

- [5.1] Robert G. Bea, "Marine Structural Integrity Programs", Ship Structure Committee Report No. SSC-365, 1992.
- [5.2] Keith A Gallion, "Repair Management System, A System to Aid in the Diagnosis of Ship Structural Failures and the Evaluation of Repair Alternatives", Project Report No. SMP 4-1, Structural Maintenance for New and Existing Ships, Dept. of Naval Arch. & Offshore Eng., Univ. of California, Berkeley, 1992.
- [5.3] Tanker Structure Co-operative Forum, "Condition Evaluation and Maintenance of tanker Structures", 1992.
- [5.4] Tanker Structure Co-operative Forum, "Guidance Manual for the Inspection and Condition Assessment of Tanker Structures", International Chamber of Shipping Oil Companies International Marine Forum, 1986.
- [5.5] Kirsi K. Tikka, Chevron Shipping, "Inspection and Structural Maintenance of Chevron Double Hull Tankers", 1991.
- [5.6] A. C. Antoniou, Production Manager, Arab Shipbuilding & Repair Yard Co., "Extension of Life of Today's Tankers", 1989.
- [5.7] Chevron Shipping Company, "Chevron Shipping Company Standards for Sacrificial Anodes", 1990.
- [5.8] Draft CFTO, "Requirements for Survey and Repair of Steel HMC Ships", Canada.
- [5.9] DnV, "Inspection, Monitoring, Maintenance/Repair", Report of Committee V.2, 11th International Ship & Offshore Structures Congress, China, 1991.

# Chapter 6 Information Systems

## 6.0 Introduction

Through a ship's life, a number of surveys will be carried out. Thousands of pieces of information and data on coatings, fractures, and gaugings will be recorded in each survey. Due to the amount of survey data, the data are difficult and expensive to record, retrieve and analyze. In addition, maintenance and repair information needs to be recorded. The information can consist of rough sketches in a repair superintendent's notebook and shipyard invoices collected in a repair file. Information that resides in the experience of individuals involved in ship maintenance also needs to be archived.

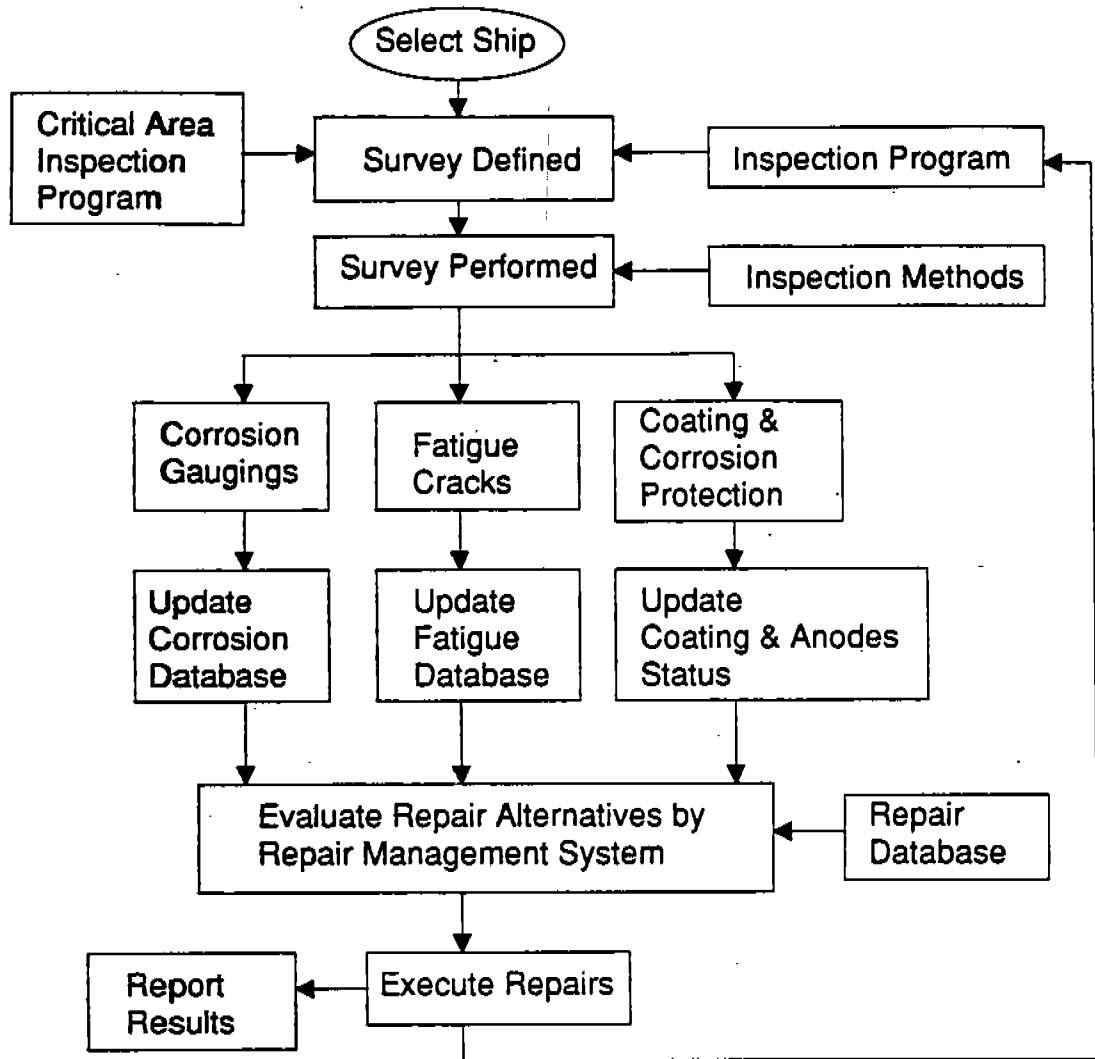
The gathering, storage, retrieval, and analysis of the huge quantity of the information can be facilitated by developing a computer and telecommunication based information system. Information systems can significantly improve the efficiency and effectiveness of ship maintenance. Development of maintenance plans, specifications, and reports can be greatly facilitated with such systems. In general, information systems are not well developed in the crude carrier industry compared with those of other industries. Some organizations have pioneered the development of computer based information systems. At the present time, these systems are still in their early stages of development.

## 6.1 Objectives of Information Systems

The general objectives of an information system development are as follows:

- Collect meaningful data.
- Store the data.
- Provide means for logical data management.
- Provide access to the relevant data easily.
- Allow for the organization of the data in a form suitable for analyses.

- Analyze the data.
- Show trends of the information.
- Communicate and report the data.



**Figure 6.1: Basic parts of information system for inspection, maintenance, & repair**

Figure 6.1 shows the basic parts of information system for inspection, maintenance and repair. Once a ship is ready for service, a series of surveys can be scheduled according the inspection program (see details in 4.2.1). The objective and scope of the internal structural inspections are defined. The access methods and data recording methods are chose, and then the survey is performed. The survey results

including corrosion gaugings, fatigue cracks, status of coating and corrosion protection system, or other structural defects are updated into the corresponding databases. Using the survey data, a Repair Management System (RMS) [6.12] evaluates repair alternatives. Finally the repairs are carried out.

How do we properly manage the computerized inspection and repair data, the existing knowledge of both successful and unsuccessful repairs, the complex analysis tools and additional knowledge to make intelligent and timely repair decisions? The answer proposed is a Repair Management System. The RMS is a computerized framework to help repair engineers make good repair decisions by assisting engineers with structural failure diagnosis and repair alternatives evaluation. The RMS is intended to provide a consistent and structured repair strategy, ensure complete and prompt repair evaluations, increase the level of expertise in the shipyard and office, and promote a sharing of repair information among ship owners, operators and shipyards.

The overall advantage of such a comprehensive Information System is that the data are in electronic format so that the data can be transferred easier and faster by modems or floppy diskettes. The data can be transmitted among ship owners, shipyards, repair yards, design offices via telephone and satellite communication. It also can enhance the efficiency of Inspection, Maintenance, and Repair (IMR). Information System also can improve IMR productivity by eliminating manual writing of the steel repair specification or manual drafting of repair drawings. In addition, it provides the capacity to quickly update corrosion, fatigue, and repair databases.

## **6.2 Components of Information Systems**

The major components of an MSIP information system are [6.1] (see Table 6.1):

- MSIP plans,
- Design information,
- Construction information,
- Operations information,
- Maintenance and repair information, and
- Inspection and monitoring data.

This information is intended to track the hull structure of a particular vessel throughout its life-cycle.

**MSIP Plans** - MSIP plans are the premises for the life-cycle operations of a particular vessel. These include plans for design (configuration, sizing, classification), construction (materials, fabrication, assembly, commissioning), operations, and IMR.

**Design Information** - The design information is intended to summarize the primary aspects that pertain to the configuration and sizing of the hull structure system including such items as design criteria, loading analyses, materials and fabrication procedures and specifications, stress, durability, and damage tolerance analyses, element and component testing programs (to verify design assumptions), the classification program, and most importantly the design documentation including design drawings and analytical models.

**Construction Information** - The construction information is intended to document the MSIP related developments that occur during the construction phase including the materials and fabrication specifications that were used, the quality assurance and control reports, the commissioning inspection reports, design variances, and the as-built drawings.

**Operations Information** - During the long-term operations phases of a ship, there are many important developments that pertain to MSIP including the voyages, cargoes, ballasting and loadings, cleaning, IGS system operations, results from in-service inspections and monitoring (structural instrumentation), and accidents (e.g. collisions, groundings, improper cargo unloading).

**Maintenance and Repair Information** - Maintenance information can consist of results from scheduled and unscheduled, temporary and permanent repairs that are made to the ship hull structure, maintenance performed to preserve corrosion protection (coatings, cathodic protection), and cleaning operations intended to facilitate inspections and maintenance.

**Inspection and Monitoring Information** - Results from in-service and scheduled inspections and surveys including visual, photographic, structural performance records (from shipboard instrumentation systems) and non-destructive testing (NDT) data.

This is a particularly data intensive portion of the system since it must archive many thousands of corrosion, cracking, and structural monitoring data points.

**Table 6.1: Summary of vessel tabular and graphical database components**  
[6.1]

<b>MSIP PLANS</b>	Design Construction Operations Inspections, Monitoring, Maintenance, Repairs
<b>DESIGN INFORMATION</b>	Design Criteria Rules Materials & Fabrication Loading Analyses Stress Analyses Damage Tolerance Analyses Durability Analyses Design Development Test Program Monitoring Program Development Classification Program Design Documentation Design Drawings
<b>CONSTRUCTION INFORMATION</b>	Specifications Builder Quality Assurance & Control Procedures Quality Assurance & Control Reports Inspections Design Variances As-built Drawings
<b>OPERATION INFORMATION</b>	Voyages Cargoes Ballasting Procedures Cargo Loading and Unloading Procedures Cleaning Monitoring Results Accidents
<b>MAINTENANCE INFORMATION</b>	Cleaning Coating Repairs Cracking Repairs Steel Renewals
<b>INSPECTION &amp; MONITORING DATA</b>	Corrosion Survey Reports Cracking Survey Reports Monitoring Program Reports
<b>REPAIR INFORMATION</b>	Coating Repairs and Maintenance Cathodic Protection Repairs and Maintenance Fracture Repairs Steel Renewals



## 6.3 Current Information System Developments

### 6.3.1 Corrosion Databases

A corrosion database was created in Ship Structural Maintenance Project (SMP) at U. C. Berkeley [6.2]. A total number of about 7,200 gauging data has been input into the database manually. The purpose of this database is to calculate the corrosion rates of different tank types, detail types or locations. The database can compute the means and the standard deviations of corrosion rates. The corrosion rates of four tank types, twenty two detail types, and nine locations were calculated.

A database must be configured to facilitate easy data entry and provide flexible data analysis. With no exception, a database management system was developed in the corrosion database, too. The database management system provides a user friendly screen to facilitate data input, analyses, and evaluations of the information.

It is not easy to create a corrosion database. A particularly difficult part of the development of the corrosion databases is the problem associated with the very large volumes of data that must be recorded and input to the computer. Generally, a single gauging survey can result in 8,000 to 10,000 readings. These readings have to be recorded on paper. However, paper based recording procedures are very labor intensive. Upon completion of the survey, the inspector has to transcribe the information to a smooth form for others to take appropriate action. It can result in long lag-times between when the data is gathered and evaluated. This results in substantial inefficiencies during the maintenance and repair operations.

A more automated process for recording the information obtained during the survey could improve the efficiency. Portable computer instrument recording and digital voice translation and recording systems are promising [6.13]. Data recorded in the tank by either of these two devices can be downloaded directly onto a computer. However, the data collection devices need to be further developed to improve their durability.

Another Problem is that there is no standard way to describe the location of a particular survey result. There is no standard coordinate system. The precise spatial location of inspection results within a hull structure is difficult during the conduct of the

inspections. Development of graphical data reporting and recording formats will help gathering, verifying and reporting such information.

### 6.3.2 Fatigue Cracking Databases

A fatigue crack database has been created in Ship Structural Maintenance Project at U. C. Berkeley [6.7]. The fatigue crack data of 10 VLCCs were provided by the SMP participants. A total number of 3584 cracks has been input into the database.

This database serves the following purposes:

- Provide a mean for the intelligent management of fatigue crack data.
- Provide insight about where to look for cracks and thus also enhance the effectiveness of ship inspection.
- Provide the mean for statistic analysis of crack locations and show trends.
- Show relative percentage of fatigue cracks for a certain type of details, and thus identify what types of details crack most frequently.

Again, there is no standard way to describe the location of a particular survey result. There is no standard coordinate system. The precise spatial location of inspection results within a hull structure is difficult during the conduct of the inspections. Development of graphical data reporting forms may help gathering such information.

In this database the location of a crack is determined as follows [6.7]. The longitudinal position is obtained by including the frame number. For the vertical position on the side shell, the longitudinal bulkhead and the transverse bulkheads the ship has been divided into three equally spaced zones, low , middle, and top thirds. This procedure allows one to compare different ships. The division into three zones was considered to be practical and sufficient for the desired degree of accuracy. The same zones have been used in the corrosion database. The horizontal position is defined with regard to port and starboard and again by the zones, which show, whether a crack is on the side shell, the longitudinal bulkhead or the transverse bulk. A further division in the horizontal direction was omitted as in the corrosion database where the omission was made for keeping the amount of input to a minimum.

In addition to the locations of cracks, the description and the geometry of the occurring cracks has to be defined. Since one detail, say, side shell longitudinal connection to web frame is very likely to be different from one shipyard to another. This fact makes it very difficult to describe the geometry of a cracked detail without the use of very detailed drawings. In the CATSIR (see section 6.3.4) database this problem is solved by relating the included information to CAD drawings, which can be seen on the screen and also be used for data input. This approach is considered to be very promising.

The database of SMP did not adopt the idea of graphical database, because the data input and the setup of a new drawing for a new crack can result in higher cost for the owners and operators of the VLCC's [6.7]. Instead, a set of keywords has been established, which allows a description of the cracked detail. These keywords also allow statistical analysis of the input data since they have a fixed format and can be used to sort the data. The information available when using this approach is less detailed, but it has the advantage that less data input is required and the keywords are easily memorized. This code is shown in Table 6.2 for longitudinal members and in Table 6.3 for transverse members.

This procedure has proved to be sufficiently simple and easy to use in analyzing survey reports.

**Table 6.2: Code for locations of longitudinal members [6.7]**

<b>Longitudinal Members</b>		<b>Code</b>
<b>Deck Plating</b>		DP
<b>Bottom Plating</b>		BP
<b>Inner Bottom Plating</b>		IBP
<b>Side Shell Plating</b>		SP
<b>Longitudinal Bhd Plating</b>		LBP
<b>Deck Longitudinals</b>	Web	DLW
	Flange	DLF
	Bracket	DLB
<b>Bottom Longitudinals</b>	Web	BLW
	Flange	BLF
	Bracket	BLB
<b>Inner Bottom Longitudinals</b>	Web	IBLW
	Flange	IBLF
	Bracket	IBLB
<b>Side Longitudinals</b>	Web	SLW
	Flange	SLF
	Bracket	SLB
<b>Longitudinal Bhd Longitudinals</b>	Web	LBLW
	Flange	LBLF
	Bracket	LBLB
<b>Deck (Longl.) Girders</b>	Web	DGW
	Face Plate	DGF
	Bracket	DGB
<b>Bottom (Longl.) Girders</b>	Web	BGW
	Face Plate	BGF
	Bracket	BGB
<b>Side (Longl.) Girders</b>	Web	SGW
	Face Plate	SGF
	Bracket	SGB
<b>Longl. Bhd (Longl.) Girders</b>	Web	LBGW
	Face Plate	LBGF
	Bracket	LBGB
<b>Center (Longl.) Girders</b>	Web	CGW
	Face Plate	CGF
	Bracket	CGB

Table 6.3: Code for locations of transverse members [6.7]

Transverse Members		Code
Transverse Bhd Plating		TBP
Transverse Bhd Stiffener	Web	TBSW
	Face Plate	TBSF
	Bracket	TBSB
(Trans. Bhd) Horizontal Stringers	Web	HSW
	Face Plate	HSF
	Bracket	HSB
(Trans. Bhd) Vertical Girders	Web	VGW
	Face Plate	VGf
	Bracket	VGB
(Trans. Bhd) Vertical Girder Stiffener	Web	VGSW
	Face Plate	VGSF
	Bracket	VGSB
Deck Transverses	Web	DTW
	Face Plate	DTF
	Bracket	DTB
Bottom Transverse (incl Inner Bottom Floor)	Web	BTW
	Face Plate	BTF
	Bracket	BTB
Side Shell Transverses	Web	STW
	Face Plate	STF
	Bracket	STB
Longl. Bhd Transverse	Web	LBTW
	Face Plate	LBTF
	Bracket	LBTB
Transverse Struts	Web	TSW
	Face Plate	TSF
	Bracket	TSB
Swash Bhd Plating		SBP
Transverse Bhd Stiffener	Web	SBSW
	Face Plate	SBSF
Others		OTH

### 6.3.3 Repair Databases

No significant repair databases have been developed. However, a catalogue of structural detail failures and suggested repairs was developed and incorporated in the "Guidance Manual for the Inspection and Condition Assessment of Tanker Structures" [6.4]. The catalogue has 210 sketches that illustrate the failed details and the proposed repairs. Most sketches show only fractures. Some buckling failures are also included. On each sketch, a list of factors contributing to the failure is described. Some sketches also include repair notes to provide more detailed recommendations, alternative repair methods where appropriate, unsuccessful repairs, and implications for new designs.

During this project, the primary problem encountered in the development of a repair database was the difficulty to retrieve set of data and information that could be incorporated into the database [6.9]. While portions of the data exist in some cases, the manpower and time required to retrieve, copy, and integrate the data into a database was prohibitive.

Many ship owners and operators have very informal systems for tracking the details of maintenance of a given ship. Documentation ranges from a coherent history of reasonably detailed shipyard repair reports on crack repairs, steel renewals, and coating maintenance to scattered shipyard invoices that define gross tonnage and areas. The documentation varies widely as a function of the diligence of the owner and operator, and as a function of the ship's life.

### 6.3.4 Critical Area Inspection Plan (CAIP)

Since the report of the Trans-Alaska Pipeline Service (TAPS) Tanker Structural Failure Study found that TAPS tankers experience a disproportionately high number of structural fractures compared to vessels in other trades, these vessels are required to have a Critical Area Inspection Plan (CAIP) by U. S. Coast Guard. CAIP is intended to be the method used by vessel companies to document and track structural failures [6.11]. In this capacity, CAIP will assist surveyors, inspectors and the vessel's crew to ensure the vessel is properly inspected and maintained. Within the CAIP, the surveyors, inspectors, and crews will be able to find detailed information on the vessel's fracture history, corrosion control systems and previous repairs. The CAIP will also contain a record and evaluation of repairs to the vessel's fractures. It is critical, for any vessel, to know what

temporary or permanent repairs have been successful in the past. Repairs completed previously that demonstrate recurring incidences of fractures should not be reused. Furthermore, the evaluation of permanent fixes will be important to the vessel's overall fitness.

The CAIP will, in the future, require management of the vast amount of information being accumulated. Thus, a computerized database system can be used for typical defect documentation and inspection results. From the database, trends and critical areas can be determined as required by the CAIP. However, not all ship owners use computers to manage the information obtained during a survey at the present time.

### 6.3.5 CATSIR System

The procedures for collecting, handling, interpreting and gauging inspection data have remained little changed over the years. An ultrasonic gauging team of two to four men would board the vessel, take gauging in the tanks, record them in a notebook, and then at the end of the day, transpose them to a draft report. It generally takes two to three weeks to complete such a survey. After leaving the ship, the team would return to their office and again transpose the data, combine it with drawings and photographs that had been taken and prepare a final report. An engineer would sort through the data and compare the gauging readings with the original thickness and wastage allowances. The areas of steel to be replaced and the surfaces to be coated are then decided. The periodic overhaul specifications and drawings are prepared manually. The whole process is time consuming and requires a lot of labor.

To improve the efficiency of the inspection and maintenance process, the basis for a comprehensive information system has been developed by Chevron Shipping. The PC-based computer information system is identified as CATSIR (Computer Aided Tanker Structure Inspection and Repair) which combines a data base program and AUTOCAD, a computerized drafting program [6.5][6.6]. It has been under development since 1986.

To use CATSIR, the gauging team personnel enters inspection information and gauging data into the CATSIR database while they are on the ship. The hull structure drawings, together with the steel grade and original thickness for each element of the structure, can be stored in the AUTOCAD program before the survey. The engineer who

interprets the gauging data and decides the required maintenance can display the structural drawing for any part of the ship's tank structure on the computer screen. Annotated comments with the display contain the general inspection information. The gauging data itself is annotated at the appropriate location on the drawing (Figure 6.2).

If it is decided to replace the coating in a certain area, the area can be outlined with a cursor and the program will calculate the number of square meters of coating required. Alternatively if it is decided to renew that part of the structure, the program will calculate the number of pounds of steel required (Figure 6.3). The data base is then updated to include the required repairs.

Chevron Shipping has developed a cooperative program with some repair yards which are aimed at producing high quality repairs [6.5]. Each of the shipyards has the CATSIR program so that information regarding the steel and coating work is submitted via computer disk. The shipyards can use the CATSIR program to produce drawings for the repair shops indicating where steel is to be renewed and coating replaced. This allows the yard to plan the work before the ship arrives so as to minimize interference between crafts.

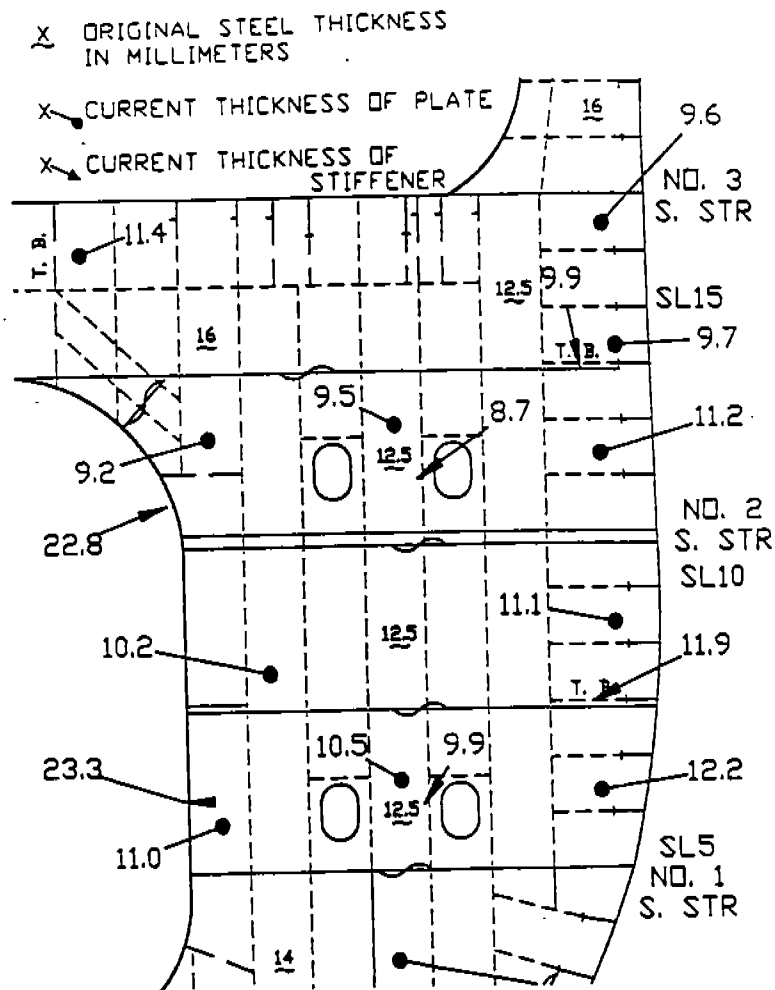
In summary, CATSIR has the following advantages:

1. It improves the productivity of the gauging team by eliminating the draft report and simplifying the final report. The final report consists of a floppy disk containing the gauging information and the comments regarding the vessel inspection.
2. It improves repair planning productivity by eliminating manual writing of the steel repair specification and by automatically calculating steel quantities and coating areas. It also eliminates manual drafting of repair drawings and provides the capability to quickly update repair specifications and drawings in the field.
3. It enhances the efficiency and quality of the inspection and repair. The inspection team and the repair team can both communicate with the home office naval architect, transmitting copies of the information contained on the floppy disks via satellite communications. Naval architects in the home office can then participate in decisions to modify the inspection program or to change the repair specification.



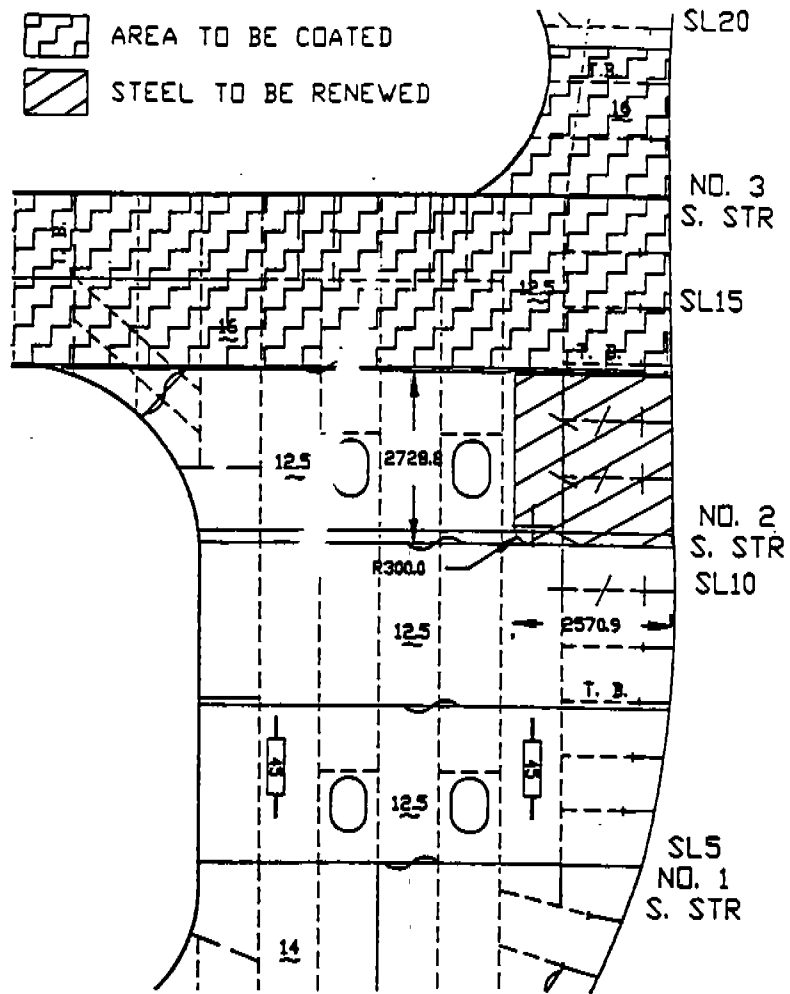
- CATSIR provides a "one-stop" data bank for all of the tanker structural maintenance data. The analyses of trends are facilitated by sorting data in the data base to collect and display gauging data, which has been obtained over a number of years, from the same location.

The primary 16 components or data modules that comprise the CATSIR 3.0 system are summarized in Table 6.4.



CATSIR DRAWING OF FORE PEAK TRANSVERSE - LOWER STARBOARD SIDE

Figure 6.2: CATSIR drawing showing gauging data [6.5]



CATSIR DRAWING OF  
FORE PEAK TRANSVERSE -  
LOWER STARBOARD SIDE

Figure 6.3: CATSIR drawing showing steel renewal areas [6.5]

143 743

**Table 6.4: Summary of CATSIR database components**

<b>MODULE 1 -- VESSEL INFORMATION</b>		
Vessel ID	Major Conversion Date	Heat Coiled
Units	LOA	Double Bottom
Vessel Name	LBP	Double Side
Vessel Class Name	Depth	Propulsion System
Owner	Beam	Screw Description
Previous Owners	Draft	Service Speed (loaded)
Classification Society	Summer LDWT	Service Speed (ballast)
Registry	Clean Product	Bow Thrusters
Delivery Date	Black Oil	Bilge Keels
Builder	SBT	Comments
Official #/Hull #	IGS	
Major Conversion Type	COW system	
<b>MODULE 2 -- DRAWING LIBRARY</b>		
Vessel ID	Drawing Name	Conversions Drawing
Tank ID	As Built Drawing	Comment
<b>MODULE 3 -- TECHNICAL INFORMATION</b>		
General comments	Key Words	Person Entering Information
<b>MODULE 4 -- SURVEY AND OVERHAUL LOG</b>		
Vessel ID	Overhaul Location	UT and NDT equipment
Survey Start and End Dates	Inspection Company	Comments
Event ID	Name of inspectors	
<b>MODULE 5 -- GAUGING INFORMATION</b>		
Vessel ID	Location	Allowable % Wastage
Drawing ID	Reading ID	% Wastage
Event ID	Original Thickness	Photo ID
Member ID	Current Thickness	Comments
Steel Type	Units Lost	
<b>MODULE 6 -- PHOTO LOG</b>		
Vessel ID	Survey/Overhaul Date	Frame No.
Tank ID	Roll No.	Caption
<b>MODULE 7 -- STEEL RENEWAL</b>		
Vessel ID	Revision #/Date	Steel Grade
Drawing Name	Renewal Type	New/Renew
Event ID	Dimensions	Weight
<b>MODULE 8 -- CARGO SPECS LIBRARY</b>		
Cargo Type	Wax Content	Water Content
Specific Gravity	Sulfur Content	Comments
<b>MODULE 9 -- TANK INFORMATION</b>		
Vessel ID	Capacity	Deck Long. Spacing
Tank ID	From-To Frame	Deck Long. Type ID
Usual Service ID	Frame Spacing	COW System
Length	Bottom Long. Spacing	Steam Coils
Beam	Bottom Long. Type ID	IGS
Depth	Side Long. Spacing	

144

(Continued)

<b>MODULE 10 -- TANK VOYAGE HISTORY</b>		
Vessel ID	Cargo Heating	Wash Date
Tank ID	Temperature	Wash Type
Route	Ballast Date	Wash Duration
Load Port	Ballast Origin	Wash Temperature
Discharge Port	% Full Ballast	Wash Pressure
Cargo Type	COW Date	Mucked Dated
Cargo Loading Date	COW Duration	# Buckets Mucked
Cargo Discharging Date	COW Temperature	% Scale
% Full Cargo Level	COW Pressure	Comments
<b>MODULE 11 -- FRACTURES</b>		
Vessel ID	Member Type	Repair Method
Tank ID	Frame No.	Steel Type
Drawing Name	Date	Causes
Category	Length, USCG Class	Photo ID
Member Name	Date Repaired	Comments
<b>MODULE 12 -- PITS</b>		
Vessel ID	Survey Date	Comments
Tank ID	Cell Coordinate	
Drawing Name	# Pits -- Range 1, 2, 3, 4	
<b>MODULE 13 -- PIPING SYSTEMS</b>		
Vessel ID	Date Installed	ID #
Drawing Name	Diameter	Degrees Rotated
Item	Inspections	Date Rotated
Length	Repairs	Schedule/Wall Thickness
Material	System	Comments
<b>MODULE 14 -- ANODES</b>		
Vessel ID	Width	Attachment Method
Tank ID	Thickness	Date installed
Date Checked	Weight	% Wastage
Drawing Name	Manufacturer	Condition
Location	Lot #	Comments
Length	Chemical Specification	
<b>MODULE 15 -- COATING REPAIRS</b>		
Vessel ID	Relative Humidity	DFT of First Coat
Drawing Name	Temperature	Stripe Coat
Event Date	Surface Preparation Method	Date/Time of Second Coat
Revision #/Date	Date/Time of Primer	Total of Coating Area
Coating Manufacturer	Type Primer	Comments
Coating Lot #	Date/Time of First Coat	
<b>MODULE 16 -- ROUTE LIBRARY</b>		
Route Name	Description	Comments

## 6.4 Summary

This project has demonstrated the need for and utility of a comprehensive information system to assist in the efficient and effective engineering and management of ship maintenance. At an early stage in the life cycle of a ship, the information system needs to be established and implemented. A vital part of this information system is a Repair Management System.

An equally important part of the information system is an industry-government-classification society-ship builder/repair yard communication system (Figure 6.4). This communication system is intended to promote the development of and sharing of information on the maintenance of ships [6.1].

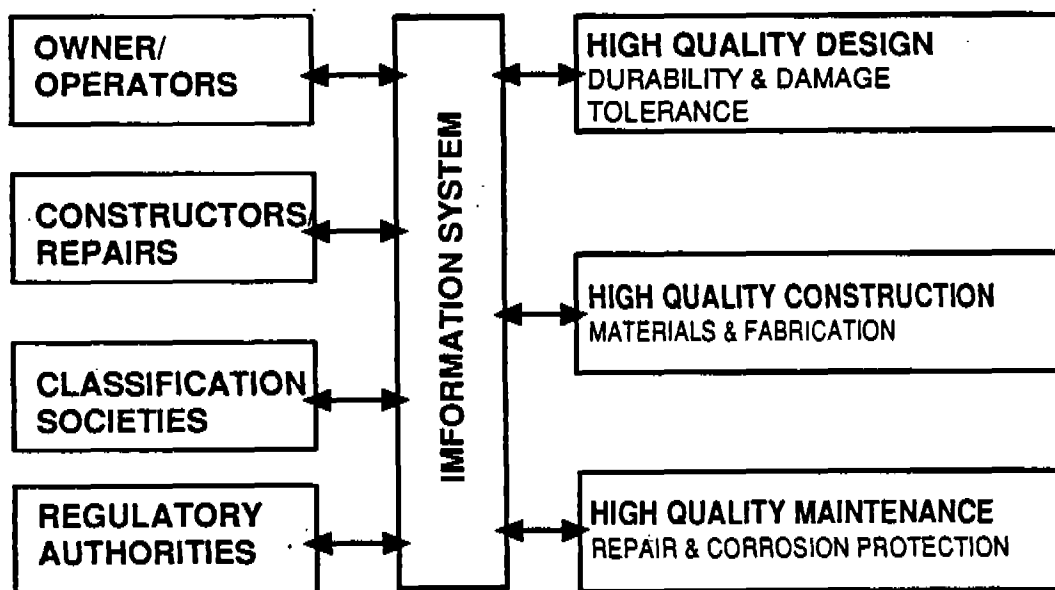


Figure 6.4: Principal components of an advanced information system [6.1]

References:

- [6.1] Robert G. Bea, "Marine Structural Integrity Programs", Ship Structure Committee Report No. SSC-365, 1992.
- [6.2] Rob Pollard, "Evaluation of Corrosion Damage in Crude & Product Carriers." Project Report No. SMP-2-1, Structural Maintenance for New and Existing Ships, Dept. of Naval Architecture & Offshore Engineering, U.C. Berkeley, 1991.
- [6.3] Stambaugh, K. A., and Knecht, J. C., "Corrosion Experience Data Requirements", Ship Structure Committee Report No. SSC-348, 1991.
- [6.4] Tanker Structure Co-operative Forum, "Guidance Manual for the Inspection and Condition Assessment of Tanker Structures", International Chamber of Shipping Oil Companies International Marine Forum, 1986.
- [6.5] R. A. Ternus, "Inspection and Structural Maintenance of Chevron's Tanker Fleet", Proceedings Marine Structural Inspection, Maintenance and Monitoring Symposium, Arlington, Virginia, 1991.
- [6.6] Tikka, K., and Donnelly, J. W., "CATSIR Computer Aided Tanker Structures Inspection and Repair Planning", Proceedings Marine Structural Inspection, Maintenance and Monitoring Symposium, Arlington, Virginia, 1991.
- [6.7] Rolf Schulte-Strathaus, "Fatigue Database Development and Analysis", Project Report No. SMP 4, Structural Maintenance for New and Existing Ships, Dept. of Naval Architecture & Offshore Engineering, U.C. Berkeley, 1991.
- [6.8] Letcher, J., Shook, D., and Sucharski, D. "A Graphical Database for Hull Fracture Repoats", Proceedings Marine Structural Inspection, Maintenance and Monitoring Symposium; Arlington, Verginia, 1991.
- [6.9] R. G. Bea, Rob Pollard, Rolf Schulte\_Strathaus, and Rob Baker, "Proceedings of the Marine Structural Inspection, Maintenance, and Monitoring Symposium", Structural Maintenance of New and Existing Ships, Arlington, Virginia, 1991.
- [6.10] V. M. Buslov, and J. B. Valdivieso, Brown & Root U. S. A., Inc. and R. D. Holdsworth, Taylor Diving, Inc., "Inspection, Maintenance and Repair of Offshore Platforms: A System Approach", Presented at the 19th Annual OTC in Houston, Texas, 1987.
- [6.11] U.S. Coast Guard, "Critical Areas Inspection Plans - CAIPs (Draft)", COMDTPUB P16700.4, NVIC, 1990.
- [6.12] Keith A. Gallion, "Repair Management System - A System to Aid in the Diagnosis of Ship Structural Failures and the Evaluation of Repair Alternatives", Project Report

No. SMP 4-1, Structural Maintenance for New and Existing Ships, Dept. of Naval Architecture & Offshore Engineering, U.C. Berkeley, 1992.

[6.13] Robert S. Holzman, Lt., USCG, "Advancements in Tankship Internal Structural Inspection Techniques", Department of Naval Architecture & Offshore Engineering, University of California, Berkeley, 1992.

DEPARTMENT OF  
**NAVAL ARCHITECTURE &  
OFFSHORE ENGINEERING**

**Advancements In Tankship Internal  
Structural Inspection Techniques**

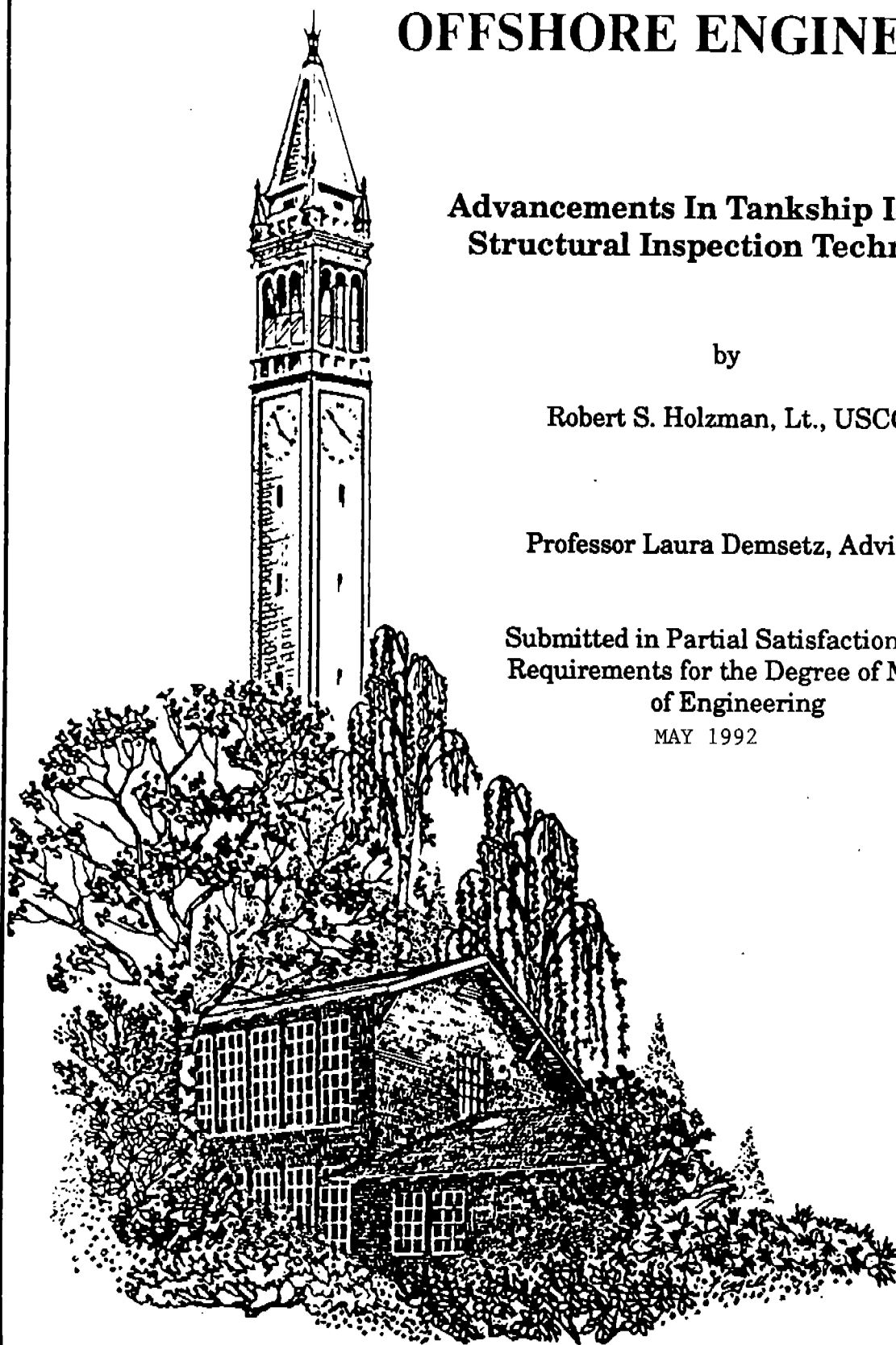
by

Robert S. Holzman, Lt., USCG

Professor Laura Demsetz, Advisor

Submitted in Partial Satisfaction of the  
Requirements for the Degree of Master  
of Engineering

MAY 1992



UNIVERSITY OF CALIFORNIA, BERKELEY, CA 94720

Tel. (510) 642-5464

149,150x

Telefax (510) 642-6128



## **Abstract**

Internal cargo and ballast tank inspections of Very Large Crude Carriers (VLCC's) and Ultra Large Crude Carriers (ULCC's) play a vital role in ensuring the safety of the crew, the vessel, and the environment. Current practice for inspection of oil tankers is difficult, expensive, and hazardous to the inspector.

With today's tanker fleet aging, and an increased awareness of the environment, more thorough inspections will likely be required. Additionally, significant cracking in Trans-Alaska Pipeline Service (TAPS) Tankers has led to an increased emphasis on inspection quality. The Coast Guard Report of the Tanker Safety Study Group dated 06 October 1989 recommends that "the Coast Guard R&D center evaluate means for internal inspection techniques and the development of high technology equipment for use in such tanks".

Inspection of the tank bottom is relatively straightforward, but inspection of other areas is typically conducted by climbing or rafting, placing the inspector in an unsafe situation. However, rafting and climbing are not the only methods of gaining access to structural members within the tank that are available to the inspector. This report describes methods currently used to gain access to structural members within the tank and discusses the pros and cons of each method. This report also investigates the way in which an inspector records information while in the tank. Presently, inspectors record information with a pen and pad. An automated method of recording information and transferring it to a more permanent storage medium is investigated. Finally, a plan for quantitatively comparing these methods is also included. Additionally, technologies that may prove useful in the future are discussed.

151,152X (151) 154X

# Table of Contents

	Page no.
1. Introduction	
1.1 The Effects of Size and Age	1
1.2 Inspection Program	3
1.3 Critical Structural Areas	8
1.4 Access	9
1.5 Inspector Safety	10
1.6 Data Acquisition and Storage	11
1.7 Contents of Report	13
2. Survey Procedures	15
3. Field Observations and Inspector Interviews	19
4. Inspector Equipment	
4.1 Tools	21
4.2 Lighting	23
5. Access	31
5.1 Improved Tanker Design	32
5.2 Access - Inspector in the Tank	41
5.2.1 Walking the Bottom	41
5.2.2 Physical Climbing without Restraint	42
5.2.3 Physical Climbing with Fall Safety Devices	43
5.2.4 Access to Side Members with Ascender	46
5.2.5 Fixed Staging	47
5.2.6 Rafting	49
5.2.7 Binoculars with High Intensity Light	53
5.2.8 Portable Staging ("Spider")	54
5.2.9 Mechanical Arm	63

	Page no.
5.3 Access - Inspector out of the Tank	66
5.3.1 Divers	66
5.3.2 Remotely Operated Vehicles (ROV's)	69
5.3.3 Acoustic Emission	71
5.4. Access - New Technology	73
5.4.1 Infrared Thermography	73
5.4.2 Laser Light Scan System (LLSS)	76
5.5. Access Summary	78
6. Recording the Survey	80
7. Quantitative Assessment of Access Techniques	87
7.1 Variables in Tank Inspection	87
7.2 Description of Proposed Experiment	89
7.3 Analysis of Results	91
7.4 Probability of Detection	95
8. Conclusion	98
I. Bibliography	102
II. Appendixes	
A. Portland Brainstorm	106
B. Hazardous Location Descriptions	110
C. List of Sample Survey Reports	120
D. Typical Tank Nomenclature	127
E. Sample Coding of Structural Members	132
F. Experimental Design Review	137
G. List of Companies Mentioned in Report	150

## List of Figures

	Page no.
1-1 Evolution of Tankers	4
2-1 Longitudinal Showing Excessive Mud	17
4-1 Eveready Intrinsically Safe Flashlights	26
4-2 Pelilite Intrinsically Safe Flashlights	27
4-3 Oreck Police Light	28
4-4 Mine Safety Appliance Cap Lamp Lighting System	30
5-1 Inertia Bar	33
5-2 Ladders along Transverse Web Frames	38
5-3 Extended Longitudinal	39
5-4 Reconfigured Underdeck Longitudinals	40
5-5 Inspector Climbing Side Longitudinals	43
5-6 Fall Safety Devices	44
5-7 Ascender	47
5-8 Fixed Staging	48
5-9 Typical Ballast Levels Sketch for 250 kDWT VLCC	50
5-10 Rafting	51
5-11 Climbing During Rafting	52
5-12 Emergency Escape Equipment/On-Deck Spotter	52
5-13 Spider Portable Staging	56
5-14 Spider Portable Staging in Tank	57
5-15 Access to Underdeck Longitudinals	58
5-16 "U" Hook	59
5-17 "U" Hook Attached to Underdeck Longitudinal	59
5-18 Stageaway Demonstration Onboard M/T	60
5-19 Portable Fixed Staging	61

	Page no.
5-20 Stageaway System in use with the Portable Fixed Staging	62
5-21 Portable Work Platform "Ziggy"	65
5-22 Ultrascan III	68
5-23 Diver entering through Butterworth Opening	68
6-1 Vocollect Talkman	82
7-1 Quantitative Assessment	90
7-2 Schematic Probability of Detection Curves	96



## List of Tables

	Page no.
1-1 Classification Society's Structural Survey Requirements	5
1-2 Inspection Area for a Pre-Marpol 250,000 DWT VLCC	6
1-3 Estimates of Internal Structures Inspected by Coast Guard Inspections	6
4-1 Inspector Equipment	23
5-1 Access Methods Summary	79
6-1 Sample Defect Data Entry	85
7-1 Linear Model for the 4 x 4 Latin Square	92

# 1. Introduction

The United States public has historically had an increasing demand for oil. This demand for petroleum has led to an increase in the total number of oil tankers in the world's fleet and an increase in the overall dimensions of tankers. The potential for catastrophic failure of these large floating structures, resulting in possible crew fatalities, loss of cargo, and an environmental disaster, demands that periodic inspection play an important role in ensuring structural integrity and safety.

With the introduction of Very Large Crude Carriers (VLCC's) and Ultra Large Crude Carriers (ULCC's), the task of conducting periodic inspections has become increasingly difficult, if not impossible. The larger size of vessels has led to difficulty in accessing the internal structural members, an increase in the time the vessel is removed from service, and an increase in inspection costs. Emphasis needs to be placed on improving the inspector's tools, increasing accessibility to the internal structural members, and providing a more efficient process for collecting data for the survey. However, before discussing improvements to the inspection process, it is necessary to understand how the evolution of the tanker has affected the inspection process.

## 1.1 The Effects of Age and Size

The world tanker fleet has aged in recent years. This has resulted in the need for increased and more extensive inspections. The fre-

quency of internal structural inspections as required by the Classification Societies is listed in Table 1-1. As the vessel becomes older, the scope of inspection becomes more extensive. The need for improved tank inspection methods is particularly important for the Trans-Alaska Pipeline Service (TAPS) vessels. These vessels have seen a higher number of structural failures than vessels engaged in other trade routes. TAPS ships comprise only 13% of the tanker fleet but experience 52% of the serious structural failures [2]. Due to this increased number of structural failures, the U.S. Coast Guard has required these vessels to be inspected more frequently. Specifically, yearly cargo block surveys must be conducted on TAPS vessels. The U.S. Coast Guard Office of Marine Safety, Security and Environmental Protection has been reestablished and is expanding the Traveling Inspection Staff (G-MT). This staff now attends all TAPS vessel dry-dockings, cargo block surveys and repair periods.

The size of oil tankers has steadily increased during the 20th century (Figure 1-1). These giants are the largest moving objects made by man; a single cargo tank can hold more than twice as much oil as an entire World War II-era tanker [32]. An indication of the area that must be inspected on a pre-Marpol 250,000 DWT VLCC is detailed in Table 1-2.

The increased size of tanks has increased the demands on the steel surveyor to an almost unrealistic level. As the size of the vessel increases, the percentage of internal structural members inspected

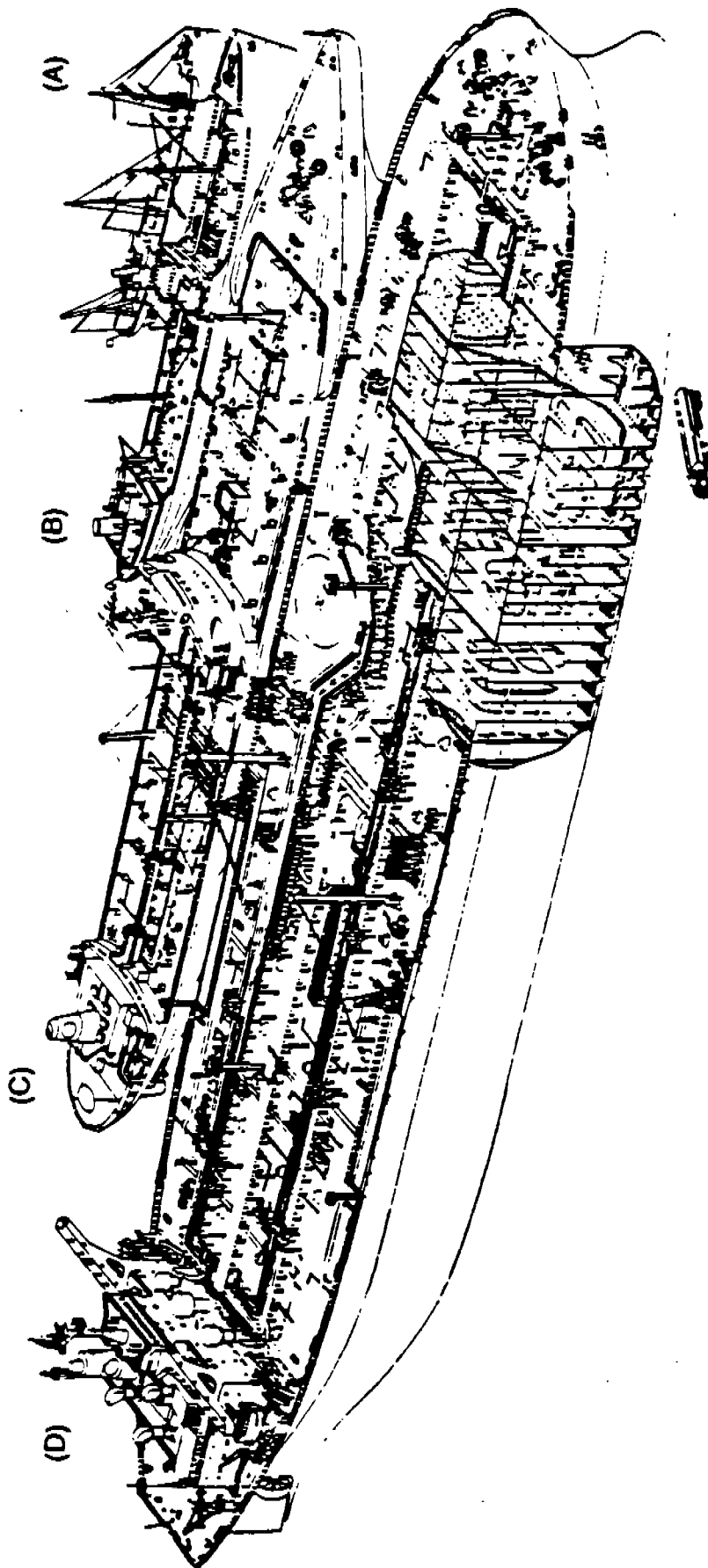


often decreases. A survey of U. S. Coast Guard Inspectors obtained estimates of internal structures inspected by Coast Guard inspections; results are shown in Table 1-3.

## 1.2 Inspection Program

An inspection program begins when the vessel is delivered and continues throughout the life of the vessel. As stated in the *Guide for Ship Structural Inspections* [11], "The purpose of inspections is to assess the capability of the structure to remain safe until the next inspection period and to accomplish any necessary corrective measures to maintain this capability. The extent of structural inspections required will always be greatly affected by cost and time considerations. In actual practice, it will be impractical, if not impossible, to execute 'perfect' inspections. However, even if the 'perfect' level of inspection cannot be obtained, the surveyors/inspectors involved in ship structural inspections must try to conduct just the sufficient amount of inspections without going to unnecessary extremes." This requires that the inspector possess judgement that often comes through experience. Improving the method of inspection and access to structural members within the tank will provide the inspector the ability to increase the percentage of tank that is inspected. With this increased coverage, the need for judgement may be reduced.

The scope of internal structural inspections as required by the Classification Societies is listed in Table 1-1. An overall survey is a survey intended to report on the overall condition of the tanks' struc-



- A - 1886, GLUCKAUF - First prototype tanker, 3,000 DWT.
- B - 1945, T-2, World War II workhorse, 16,500 DWT, 525 built.
- C - 1962, MANHATTAN - 115,000 DWT (after conversion to an ice-breaker in 1969), the largest U.S.-flag ship at time of building.
- D - 1977, KAPATAN GIANNIS - (formerly ESSO ATLANTIC) 509,000 DWT, length: 1,334 ft., third largest tanker in the world.

SOURCE: National Geographic Magazine

Ref: [32] "Tanker Spills: Prevention By Design"

Evolution of Tankers

Figure 1-1

Age < 5 Special Survey No. 1	5< Age < 10 Special Survey No. 2	10 < Age < 15 Special Survey No. 3	15< Age < 20 Special Survey No. 4
1. Overall Survey of all tanks and spaces	1. Overall Survey of all tanks and spaces	1. Overall Survey of all tanks and spaces	1. Overall Survey of all tanks and spaces
2. Close-up Survey:	2. Close-up Survey:	2. Close-up Survey:	2. Close-up Survey as for Special Survey No. 3 with additional transverse as deemed necessary by the Surveyor
a) One complete transverse web frame ring including adjacent structural members (in one ballast tank if any, or a cargo tank used primarily for water ballast)	a) One complete transverse web frame ring including adjacent structural members in one wing tank (in one ballast tank, if any, or a cargo tank used primarily for water ballast)	a) All complete transverse web frame rings including adjacent structural members in all ballast tanks and in one cargo wing tank	
b) One deck transverse including adjacent deck structural members in one cargo wing tank	b) One deck transverse including adjacent deck structural members in each of the remaining ballast tanks, if any	b) One complete transverse web frame ring including adjacent structural members in each remaining cargo wing tanks and one bottom and one deck transverse in each cargo center tank	
c) Lower part of the girder system including adjacent structural members on one transverse bulkhead in one ballast tank, one cargo wing tank and one cargo center tank	c) One deck transverse including adjacent deck structure in one cargo wing tank and two cargo center tanks	c) One complete girder system including adjacent structural members on the transverse bulkheads in all cargo and ballast tanks	
	d) The complete girder system including adjacent structural members on the transverse bulkheads in one wing tank (in one ballast tank, if any, or a cargo tank used primarily for water ballast)		
	e) Lower part of the girder system including adjacent structural members on one transverse bulkhead in each of the remaining ballast tanks, one cargo wing tank and two cargo center tanks		

Source: Guidance Manual For The Inspection and Condition Assessment Of Tanker Structures [1]

Classification Society's Structural Survey Requirements  
Table 1-1

163

Vertical Height to Climb for Survey	10,700 M / 35,000 Ft.
Tank Section Area to Inspect	300,000 M <sup>2</sup> /72 Acres
Total Length of Welding	1,200 KM/750 Miles
Total Hand Welding (included in above)	390 KM/240 Miles
Total Length of Longitudinal Stiffeners	58 KM/36 Miles
Flat Bottom Area	10,700 M <sup>2</sup> /2.6 Acres
1.0 Percent Pitting	85,000 Pits (each 0.40 mm diameter)

Source: "Large Oil Tanker Structural Survey Experience" [8]

Inspection Area For A Pre-Marpol 250,000 DWT VLCC

**Table 1-2**

20 - 40 KDWT approximately 75%
40 - 80 KDWT approximately 50%
80 - 120 KDWT approximately 30%
120 - 200 KDWT approximately 25%
200 and up KDWT less than 20%

Source: "Report of the Tanker Safety Study Group" [3]

Estimates Of Internal Structures Inspected By

Coast Guard Inspections

**Table 1-3**

tural integrity and corrosion condition in a relatively short period of time and to determine the extent of additional close-up surveys required. A close-up survey is one where the details of structural components are within the inspection range (within hand's reach) of the surveyor.

In addition to classification societies and U.S. Coast Guard required inspections, vessel owners establish their own program and schedule for internal inspection intervals. The Coast Guard Report on the Trans Alaska Pipeline Service (TAPS) Tanker Structural Failure Study found wide variation among owner's inspection intervals, ranging from spot checks of ballast tanks after each voyage, to general surveys of all tanks once a year, to complete internal exams every six months. Many operators also conduct internal surveys of ballast tanks and, to a lesser extent, of cargo tanks, 3 to 6 months prior to a vessels' scheduled drydock exam in order to find and document problem areas before the shipyard period. The cost involved in repairing a crack found after a ship is already in dock is invariably higher than listed on a bid specification [2].

A thorough inspection can only be achieved when there is close cooperation between the crew, owners representatives, class surveyors, and Coast Guard inspectors. Each of these individuals has insight as to problem areas on which the inspector may wish to concentrate his/her efforts. The Report of the Tanker Safety Study Group [3] found that tankers are often not prepared for Coast Guard inspections and

that the port engineer and crew are spread too thin to assist in the required inspection. Nonetheless, the need for cooperation is essential to the common goal: to insure the safety of the crew, the environment, and the vessel.

### **1.3 Critical Structural Areas**

The formidable dimensions shown in Table 1-3 require a tradeoff between a complete inspection, which is time consuming and expensive, and partial inspection, which most certainly will miss some defects inside the tanks. The question then becomes "What compromise not only facilitates commerce but is also in the best interest of the safety of the crew, the vessel and the environment?"

Since it is unrealistic to expect 100% of the internal structural members to be inspected, increased importance is placed in targeting critical structural areas. A critical structural area can be defined as an area subject to high stresses or with a history of problems. The inspector generally conducts a survey to determine that the vessel is safe for the route intended and until the next inspection period. In order for the inspector to conduct a thorough inspection, it is necessary for all parties involved with the vessel, from the crew to the naval architect, to inform the inspector as to the location of critical structural areas. This information must be disseminated to the inspector so that everyone involved with the ship including the owner, the crew, and government agencies, is satisfied that a thorough survey has been con-

ducted without the need to inspect 100% of the vessel. The results of the Structural Maintenance for New and Existing Ships Project at the University of California at Berkeley [4] will further help to identify critical structural areas.

#### **1.4 Access**

The increased size of vessels has made accessibility an important issue in the tanker industry. Access to and inspection of the tank bottom is relatively easy. For the upper regions of the tank, most in the industry believe that ballasting the tank and rafting combined with random scaffolding is the best method for conducting an internal structural examination (a detailed discussion of these methods can be found in sections 5.2.5 and 5.2.6). However, numerous alternatives to these methods have been tried with limited success. No method has proven thus far to be more effective than a close up visual inspection by a trained and experienced inspector. Often the inspector is required to push away wax buildup or chip away at rust layers. Most methods that do not allow for a "hands-on" inspection lack this important capability. However, in certain applications, each method has its advantages.

Currently the area most difficult to access, and consequently to inspect, is the deckhead area. Full staging is possible, but costly. To provide a means of escape when rafting, the tank may only be ballasted to within 1 meter of the overhead transverses. Thus, a close-up survey on vessels with deep transverses is not possible by the rafting method. Additionally, rafting has its inherent elements of danger. Alternative

methods to rafting and scaffolding need to be investigated to reduce the direct cost and indirect costs due to the vessel being out of service, to increase the safety of the inspector and, ultimately, to increase the quality of the inspection.

### **1.5 Inspector Safety**

The inspector is frequently required to compromise safety so that an adequate inspection is conducted. As previously stated, a recent survey of Coast Guard inspectors found that unless a tank is staged and lit, only 20% of a tank's internals is adequately inspected during a routine drydock examination on vessels greater than 200 KDWT. As stated in section 1.2, improved access would help to increase this percentage.

The physical nature of the inspector's job currently requires it to be a younger person's profession. Minimizing the need for climbing, in order to gain access would help to reduce fatigue.(see sections on climbing, 5.2.2, 5.2.3). As shown in section 5.2.1, merely inspecting the tank bottoms covers acres of area which in itself can be a tiring experience. While inspection requires the physical capabilities of a younger person, it also requires many years of experience that cannot be found in a younger inspector. Experience gives the fully qualified inspector the ability to detect and evaluate defects. By reducing the need for climbing, the inspector would be able to continue working longer without tiring.

Besides the need for improved access, the cleanliness of a tank



has a direct relation to the quality of the inspection and to safety. Although cleanliness is a subjective term, for a high quality inspection the tank needs at a minimum to be free of standing water, free of sludge and mud, and to the extent possible, free from wax buildup. If a ballast tank is full of mud in the bottom it is impossible to inspect the bottom longitudinals and the welds connecting the bottom longitudinals to the bottom plating. In addition to the lack of ability to inspect, this wet mud is extremely slippery and provides an unsafe environment for the inspector.

### **1.6 Data Acquisition and Storage**

As previously discussed, TAPS vessels are required to conduct increased inspection activities. In addition to this, these vessels are required to have a Critical Area Inspection Plan (CAIP)[2]. The CAIP is a management tool that serves to track the historical performance of a vessel, identify problem areas, and provide greater focus to periodic inspections. The CAIP is required to contain among other things, historical information, active repair areas, and trends. The CAIP should also include areas that have been determined to be critically stressed areas during the structural design analysis including specific inspection requirements. The CAIP is ultimately intended to assist surveyors, inspectors, and the vessel's crew to insure the vessel is properly inspected and maintained.

The CAIP will, in the future, require management of the vast amount of information being accumulated. A computerized database

system can be used for typical defect documentation and inspection results. From the database, trends and critical areas can be determined as required by the CAIP. Not all ship owners use computers to manage the information obtained during a survey. However, some, such as Chevron, have recognized the need.

Chevron has developed a computerized management tool called CATSIR (Computer Aided Tanker Structures Inspection and Repair) [7]. The program was initially developed in order to simplify the handling of gauging and inspection data. The program is able to record and manipulate inspection and repair data for tanker structures. It links a database program with a graphics package that is capable of displaying information in drawing or report format. CATSIR has the capability of providing information required for the CAIP including determining trends and the location of critical structural areas. Although development of a database management system is labor and cost intensive, the ability to update the CAIP and prepare repair specifications could help make up for this initial investment.

A computer database tracking can assist not only the owner, but also class surveyors, structural engineers and Coast Guard inspectors. With this computer database system in place, an automated method to record the defects while conducting an internal structural examination becomes desirable. With an automated recording system, the inspector would be able to download the structural inspection data into the computer database system.

## 1.7 Contents of Report

This report evaluates the inspection process, including accessibility, inspector's equipment, and data acquisition. Chapter 2 discusses survey procedures, the three phases of a survey, confined space entry, and areas of concern to the inspector during an internal structural survey. Chapter 3 explains the field observations and inspector interviews that were used as background for this report. Chapter 4 analyzes the equipment the inspector carries during an inspection, including lighting.

The Guidance Manual for the Inspection and Condition of Tanker Structures published by the Tanker Structure Cooperative Forum [1] discusses in limited detail those methods that are currently available to conduct an internal tank inspection. Chapter 5 presents in greater detail the methods that are the most promising and provides a discussion of both the pros and the cons associated with each method. Further, the report discusses promising alternative methods and currently untried inspection methods that merit further research efforts. Additionally, tanker design for improved accessibility is investigated.

The increased importance of survey information management and determination of trends has caused some shipowners to switch over to computer-based information systems. The ship inspector has historically recorded defects with a pen and pad. Chapter 6 proposes alternative methods for recording the defects found during the inspection of the internal structural members including a computer-based automated

system.

Finally, Chapter 7 provides a plan to experimentally quantify the differences between a select group of commonly used inspection methods used to gain access. The proposed experiment will provide insight into the adequacy and quality of the alternative inspection methods. Currently, most analysis of the alternative methods is based on individuals' opinions. The proposed experiment will attempt to qualitatively rank the alternative methods based on number of defects found within the tank and time required to conduct the inspection. This experiment will also be a first step in understanding the probability of detecting defects inside the cargo tanks.

The Report of the Tanker Safety Group recommends "The Coast Guard R&D center evaluate means for internal inspection techniques in large tanks and the development of high technology equipment for use in such tanks, including high intensity lights, high definition video equipment, or any other device that may be suitable for use by the industry. A joint project with major oil companies may be helpful to obtain the benefits of their experience". This report lays the groundwork for such a project. Chapter 8 summarizes the important findings of this paper and makes specific recommendations including plans for continued research.

## 2. Survey Procedures

There are three phases to a survey: preparation, the actual survey, and reporting the information found. This report does not provide a detailed explanation of how the inspector's job is carried out. However, it is important to understand the nature of the inspector's job before discussing other aspects of inspection.

Before an inspection, appropriate preparation is critical. It is important to know the critical structural areas since physical requirements, cost, and time prohibit a 100% structural survey. Discussion with all involved parties, including the crew, classification society, and ship representatives, gives the inspector insight into the location of critical areas so that a more focused inspection can be conducted. In addition to determining critical structural areas, the inspection team should discuss safety and emergency procedures with the ship's crew. It is also important to review the ship's plans (including the CAIP if provided) to determine the layout of the vessel, numbering of the structural members, and the critical areas.

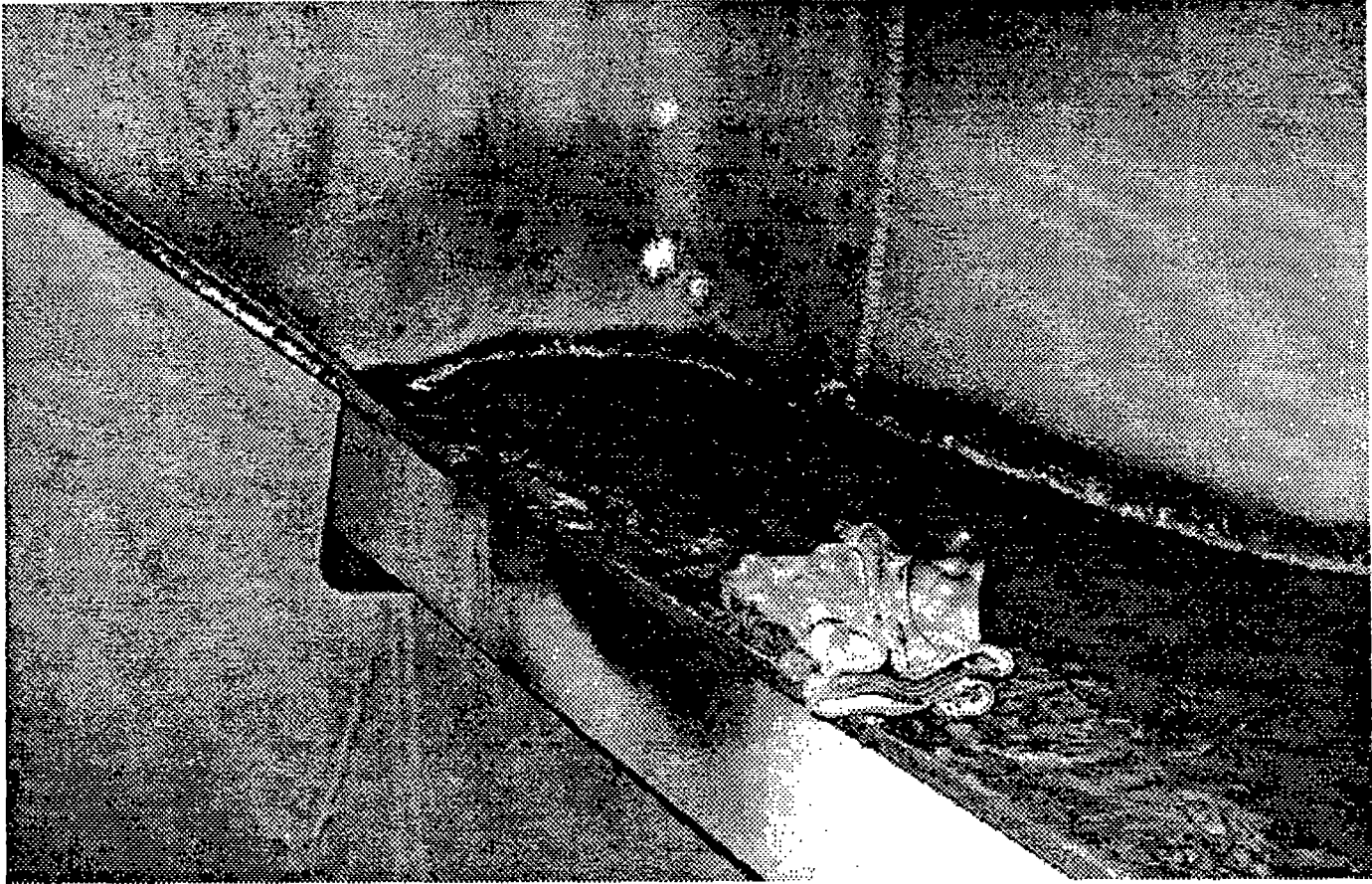
All ship inspectors have some general knowledge of confined space entry procedures. Too many lives have been lost by not following standard marine safety practices. U.S. Coast Guard inspectors require Marine Chemist Certificates to certify the tank safe for entry. Tank entry should not be conducted without a minimum of 19.5% oxygen, less than 1% of the Lower Explosive Limit (LEL) of total hydrocarbons, less than 30 ppm carbon monoxide, less than 10 ppm hydrogen sulfide,

and less than 10 ppm benzene [1]. When there is more than one ppm benzene, a filter mask with organic vapor cartridges must be worn. Benzene standards have recently been lowered by OSHA; consequently, care must be taken when measuring a tank for benzene. Sophisticated equipment such as a spectroanalyzer is recommended, as detector tubes are inaccurate at levels of 1 ppm benzene. Forced ventilation should always be installed prior to and used during the internal structural survey. The marine chemist should always be consulted if there are any questions prior to entry.

Cleanliness of the tank is essential before a survey is conducted. Without a clean tank, many structural members, such as the bottom longitudinals, are hidden and an assessment of their condition is impossible. At a minimum, the tank should be free of standing water, free of mud in the ballast tanks, and free of as much wax buildup as is possible. The side longitudinals in the ballast tank shown in Figure 2-1 have an excessive amount of mud on top and against the side plating. A tank in this condition makes an adequate inspection impossible.

Climbing of the side structural members should be limited to 3 meters above the tank bottom and 6 meters above the water when rafting surveys are conducted. Even at 3 meters above the bottom, serious injury could result in the event of a fall. The inspector should never enter a tank alone, and someone should be standing by on deck with emergency escape equipment at all times during the survey. Heat and humidity can limit in tank inspection time and should be considered prior to the survey.

When an inspector is conducting an internal tank inspection



Longitudinal Showing Excessive Mud  
(gloves in foreground)

**Figure 2-1**

three basic defects will be recorded: cracking, corrosion, and buckling. Additionally the inspector assesses the condition of the coatings, corrosion rates, pitting and percentage of pitting covering the plate, condition of the piping and fittings, and the condition of the handrails, ladders and walkways. Areas that are of concern to the inspector as listed in the "Guidance Manual For The Inspection and Condition Assessment of Tanker Structures" [1] include (For typical tank nomenclature see Appendix C):

- (1) Ends of principal girders, stringers, transverses and

struts with associated brackets. Particular attention should be paid to toes of brackets.

(2) Bracketed ends of shell, deck and bulkhead stiffeners.

(3) Connection of shell, deck and bulkhead longitudinals to transverse web frames. Particular attention should be paid to the side shell connections between full load and ballast waterlines.

(4) Any discontinuities in the form of misalignment or abrupt changes of section.

(5) Plating in way of cutouts and openings.

(6) Areas which show any evidence of damage or buckling.

It is necessary for the inspector to focus on historically suspect areas to optimize the effectiveness of the survey. The importance of good communication between the various involved parties cannot be overstated.

Upon completion of the survey, the inspector is required to transfer the defects list to a smooth form (see chapter 6) so that repair specifications can be made. Repair specifications include the location within the tank, type of defect, and recommended repair.



### 3. Field Observations and Inspector Interviews

Sources of information for this report, besides those listed in the bibliography include oil company representatives, ship repair personnel, ship surveyors, U.S. Coast Guard and American Bureau of Shipping inspectors, and equipment manufacturers. To gain a clear understanding of tank inspections, it was necessary to observe first-hand the inspection procedure. The author had 2 years of previous inspection experience with the U.S. Coast Guard. However, for this report, the author attended several inspections. By accompanying the inspector and acting as an observer, it was possible to stand back and observe the manner in which the inspection was conducted and the difficulties the inspector encountered. This field experience also gave further insight into the techniques, methods and equipment that may help to improve ship inspections.

The ships boarded for field observations include: *M/T Exxon Benicia, Golden Gate, Thompson Pass, Brooks Range, Arco Fairbanks, Kenai* (double hull tanker), and the *Exxon North Slope*. A wide range of techniques were employed to gain access to the internal structural members.

In addition to field expeditions, a brainstorming session with experienced steel inspectors was held in Portland, Oregon on 30 May 1990. The brainstorming session was conducted to determine problems faced by inspectors. This interaction with the inspectors was important to the investigation, so that conclusions would not be based solely upon academic information. Without input from the inspector,

any recommendations concerning ship inspections might ultimately be rejected when implemented. Those attending the brainstorm session included representatives of the U.S. Coast Guard, American Bureau of Shipping (ABS), and Ron Nisbet Associates Inc. inspectors. Unfortunately representatives from the major oil companies were not able to attend. A list of questions raised at the session and participants responses is included in Appendix A.

## **4. Inspector Equipment**

### **4.1 Inspector's Tools**

In order for the inspector to safely and efficiently conduct an inspection, a wide variety of tools are available. The inspector must decide for himself/herself those which are most important. It would be unsafe and physically impossible for the inspector to carry all the tools that would make his/her job more effective.

The bare minimum that an inspector needs when conducting an inspection includes the following: coveralls, hardhat, steel tip shoes, leather or cotton gloves, flashlight, pen and pad, chalk or spray paint (for marking structural members where defects are located) and a chipping hammer to chip away rust, scale, and oily residue buildup. A hardhat with reflective tape are recommended when a spotter is provided for the inspection team. Flashlights should be intrinsically safe and are discussed in more detail following this section. A second mini flashlight should be carried in the event the primary flashlight fails and emergency escape is necessary. Half-mask filter respirators are required when the benzene levels in the tank are not reduced to an acceptable level. Coast Guard policy allows tank entry when benzene vapors are below 1 ppm and with a filter half-mask when below 10 ppm. Tank entry is not permitted when benzene vapors are above 10 ppm. Ear plugs are also recommended as tests have shown that noise levels in tanks equipped with forced ventilation exceeds 85 dB. This equipment is often the maximum that the inspector can carry.

Forced ventilation can make communications between the

inspectors difficult while in the tank. Scott Aviation<sup>1</sup> manufactures a voice amplification system for their self contained breathing apparatus (SCBA). The voice amplification system is not currently available for the filter half mask. However, this type of voice amplification system would work well in improving communication while in the tank.

Inspectors have a difficult job climbing around the structural members and many choose to carry only the minimum necessary gear. Additional safety gear the inspector may wish to carry includes safety glasses, pocket oxygen analyzer, and an Emergency Escape Breathing Apparatus (EEBA). An EEBA is a portable canister that provides approximately three minutes of oxygen, enough to allow the inspector time to escape the tank in an emergency. The device is housed in a small bag approximately one sq. ft. that is slung over the shoulder to be donned quickly in an emergency. Coast Guard policy requires the Coast Guard Inspector to carry an EEBA. Although it is a good piece of safety equipment to have in a confined space such as a tank, the size of the unit makes it impractical for the inspector to carry while conducting his job. The fact that the unit could get hung up while the inspector climbs around the tank shows that there is a safety tradeoff when choosing whether to carry the device or not.

Other equipment the inspector may wish to carry includes a wire brush, a putty knife, and a 35 mm camera for a still image history of the defects found in the tank. A 35 mm camera has proven to be an excellent method to document defects within the tank. However, the

---

<sup>1</sup> Information on all companies mentioned is included in appendix G

flashes on most 35mm cameras are not intrinsically safe. Care must be taken when using 35 mm cameras and their use should be restricted to only when the tank is certified safe for hot work by a certified marine chemist.

Any improvements considered for the inspection process must consider the amount of gear the inspector is required to carry. If an additional item or devise is suggested it should be used as a replacement to a piece of gear already carried by the inspector. Otherwise, any additional gear recommended to the inspector will more than likely be found laying at the tank hatch entranceway. A summary of the equipment carried by the inspector is included in Table 2-1

#### **4.2 Lighting**

The steel inspector generally relies on hand held flashlights for illumination. The background light from the hatch covers in the cargo and ballast tanks is barely adequate to allow safe walking around the tank. Several type of tanks, such as the fore peak tank and after peak tank, and generally vessels with double hulls, have areas that have no background light. When the ship is in the yard and the tank is gas free and certified safe for hot work by a Marine Chemist, a string of lights may be hung in the tank to increase visibility and allow movement about the tank.

There is a wide range of flashlights from which the inspector can choose and the decision is generally based on personal preference. Some inspectors prefer to carry a second mini flashlight which helps to provide a safe exit from the tank if the primary flashlight fails. Many company policies recommend intrinsically safe flashlights when inspecting tanks. Specifically the "Guidance Manual for the Inspection

## Required Equipment for U.S. Coast Guard Inspectors

Equipment	Required	Recommended
Hardhat	X	
Steel Tip Shoes	X	
Coveralls	X	
Gloves		X
Flashlight	X	
Pen and Pad		X
or Chalk		X
or Spray Paint		X
Chipping Hammer		X
and/or Wire Brush		X
and/or Putty Knife		X
Half Mask		
Filter Respirator	X (when benzene exceeds 1 ppm)	
Safety Glasses	X	
Pocket Oxygen Analyzer	X	
EEBA	X	
35 MM Camera		X

### Inspector Equipment

**Table 4-1**

183

and Condition Assessment of Tanker Structures" [1] states that torches and lights should be of intrinsically safe design. Additionally, U.S. Coast Guard Navigation and Inspection Circular (NAVIC) No. 2-89 states that intrinsically safe systems are required in all hazardous locations. Intrinsically safe portable battery powered equipment, such as walkie talkies, combustible gas detectors, and flashlights are evaluated on their internal circuitry. Intrinsically safe portable equipment must be tested and approved for the intended application by a nationally recognized testing laboratory (currently UL, FM, CSA, or MET). Specific hazardous areas are listed in NAVIC 2-89 (Appendix 8) and are included in Appendix B of this report.

Cargo tank areas and open deck areas over the cargo area are considered more hazardous than class I Division I locations. Further regulations requiring the use of intrinsically safe equipment for tankships are contained in 46 CFR 111.105 and are also included in Appendix B. Although the tank may have been gas free prior to entry, there is always the possibility of a lingering gas pocket, especially when the inspector breaks up the sludge in oil carrying tanks.

The manufacturers listed below distribute lights that are typically used by inspectors. This list may not be all inclusive.

Eveready manufactures two models of intrinsically safe UL approved flashlights, a 2 D cell battery flashlight and a 6 volt battery flashlight (Figure 4-1). For tank inspections, the inspector generally prefers a 6-volt flashlight due to the stronger intensity of the beam. When using the larger 6-volt model, the inspector typically attaches a line to the light so that the light can be strung over his shoulder.

Pelican Products Inc. manufactures the MityLite (2 AA batter-

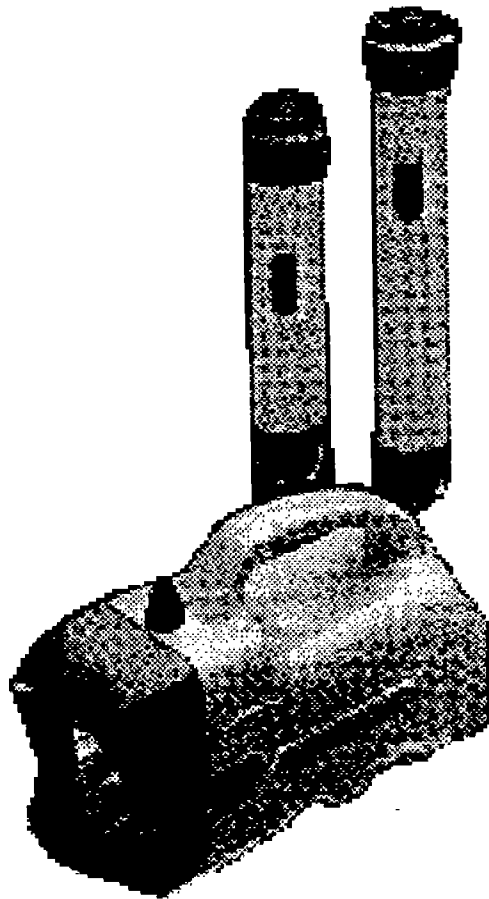
ies), Super Saberlite (3 C cell batteries), Pelican Pro (2 D cell batteries), King Pelican Lite (8 D cell batteries and produces 100,000 candlepower) (Figure 4-2). Pelilite flashlights are currently being tested by the U.S. Coast Guard Marine Safety Office San Francisco for suitability. These lights are approved by FM and CSA as intrinsically safe.

Another flashlight that the U.S. Coast Guard Marine Safety Office Portland uses is the Oreck police type floodlight (Figure 4-3). This flashlight is not intrinsically safe and use is generally restricted to the shipyard where the tanks are certified by a marine chemist to be gas free, safe for men, and safe for hot work. Even under these circumstances the inspector should be careful when scraping oil residue buildup, which can lead to the possibility of escaping combustible gas vapors. The use of intrinsically safe flashlights is the recommended alternative. This Flashlight puts out an extremely bright beam but is far larger than other flashlights that are available to the marine inspector.

Other flashlights are manufactured that carry a Mine Safety and Health Administration (MSHA) approval. For a tank that has been certified gas free this provides an equivalent level of safety. Non-intrinsically safe flashlights should not be left around for general shipboard use when the vessel may be carrying and transferring cargo and containing potentially explosive atmospheres.

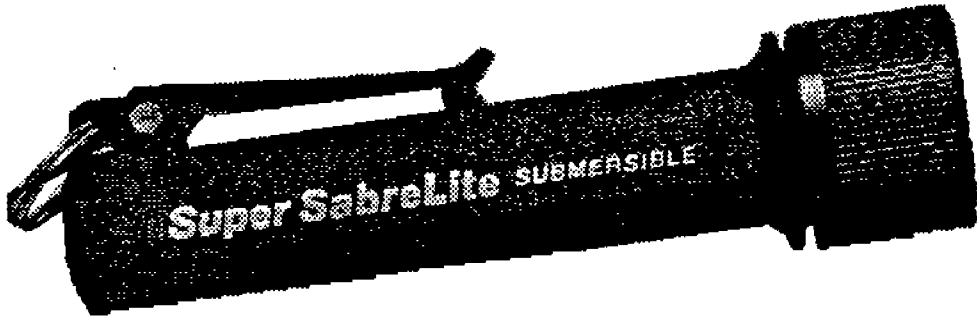
One such light is the Mine Safety Appliance Cap Lamp Lighting System ( Figure 4-4). This system has often been used by marine chemists during tank inspections. The lamp is MSHA approved and is attached to a hardhat. This is especially convenient to the inspector in that it frees his hands to climb, chip away rust, or carry out whatever





Eveready Intrinsically Safe Flashlights

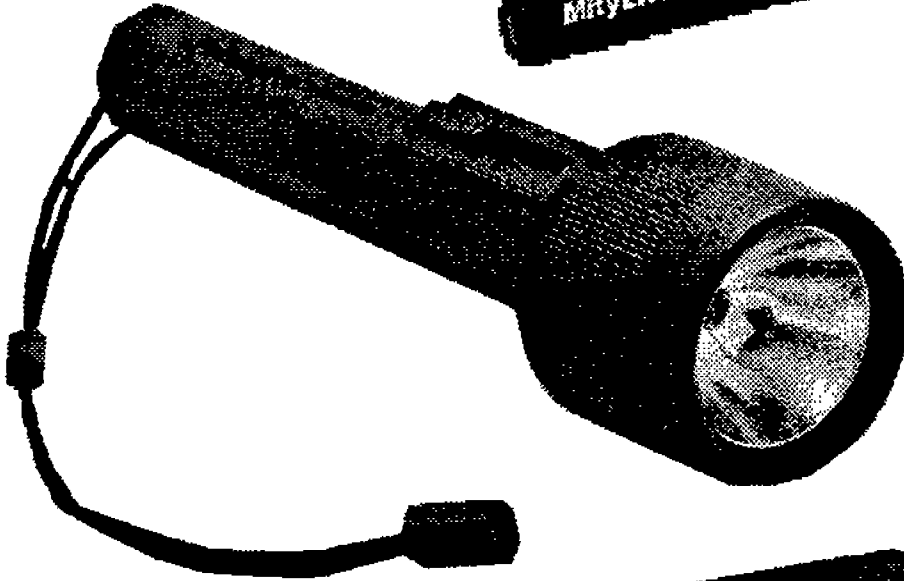
Figure 4-1



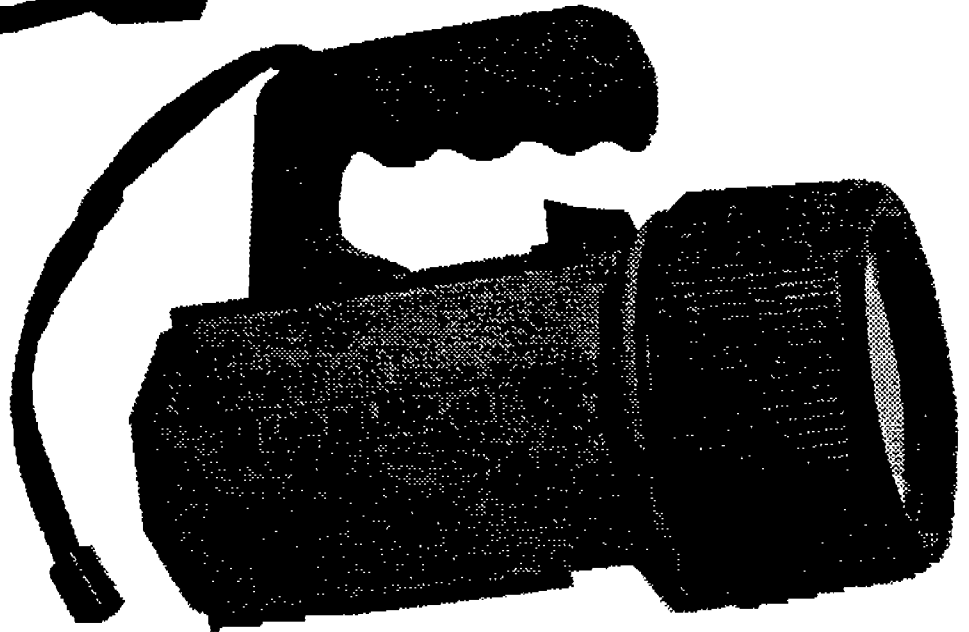
Super SabreLite



MityLite



Pelican Pro



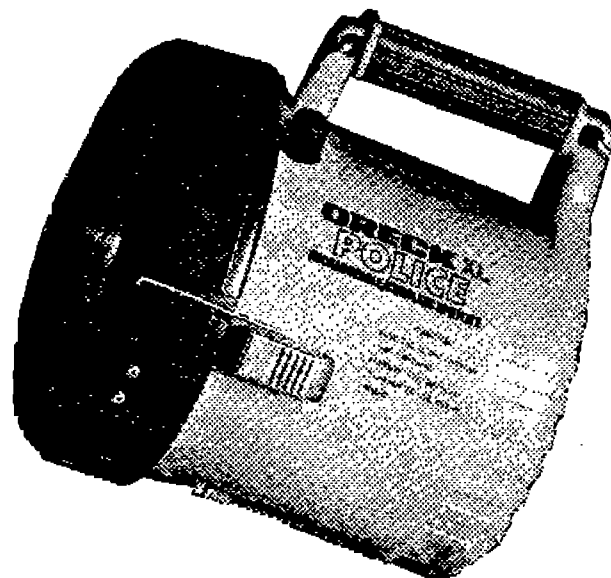
King Pelican

Pelilite Intrinsically Safe Flashlights

Figure 4-2

other task is required. A small battery pack is attached to a belt worn around the inspectors waist. Operating time before recharging is approximately 10 hours. The Krypton filled bulb has two filaments so that if the working filament burns out, the lamp can be switched quickly to the safety filament allowing the inspector to leave the tank and return to a location where a new bulb can be safely inserted.

The MSHA Cap Lamp Lighting System was recently tested by U.S. Coast Guard inspectors at the U.S.C.G. Marine Safety Offices in Portland and San Francisco. The system received mixed reviews. The inspectors generally found the beam to be extremely powerful, enjoyed having their hands free during the inspection, and felt that by using

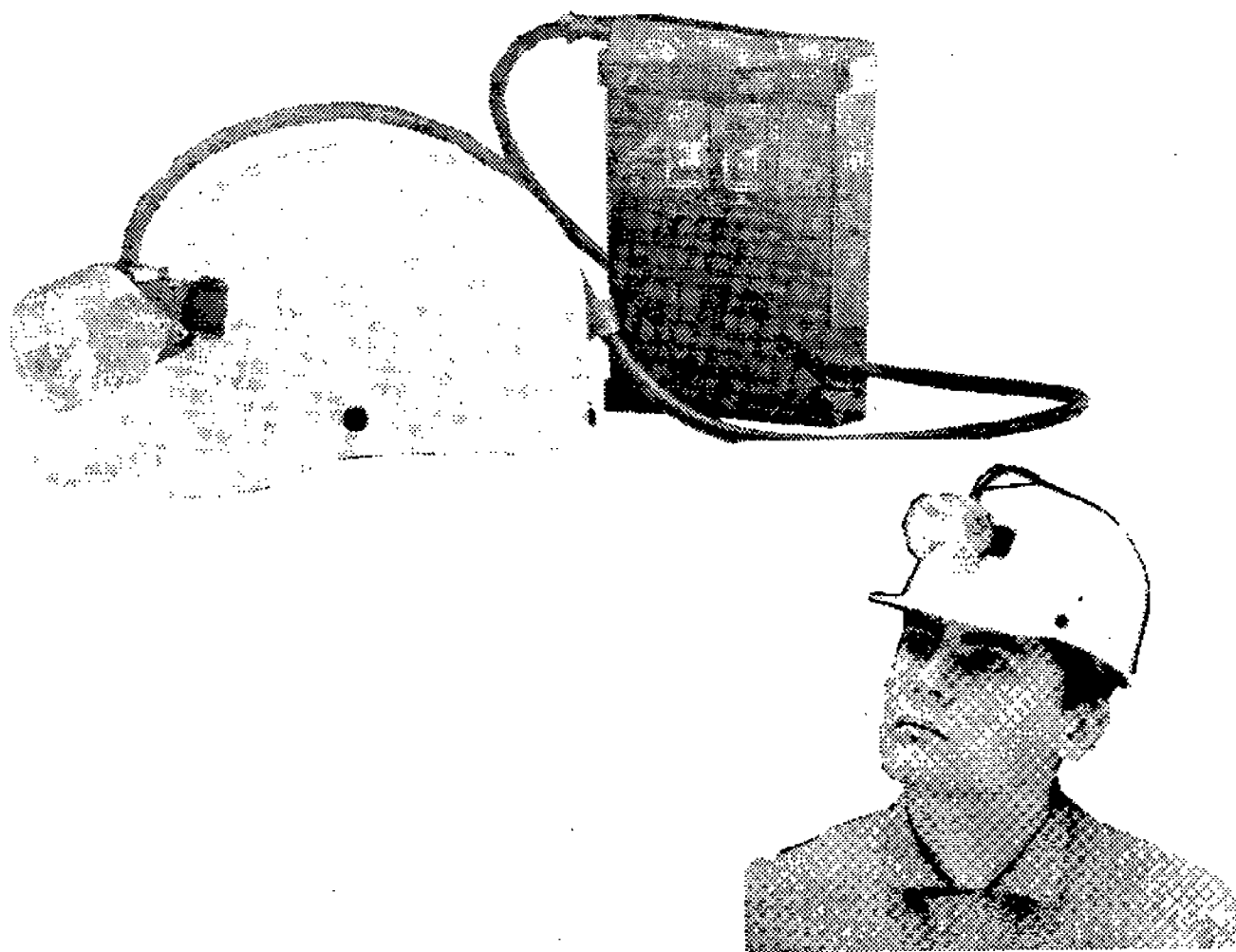


Oreck Police Light

Figure 4-3

the system, tank inspections were safer. However, most of the inspectors who used the system felt the battery pack worn around the waist was heavy and cumbersome. Also, some inspectors stated they had to direct the light with their head. They found it to be uncomfortable to lift their head high to see the upper regions of the tank. Some inspectors also stated that they had to hold onto the cap to keep it from falling off when tilting their heads back. A neck strap for the cap would solve this problem.

This system appears to be better suited to the marine chemist. The marine chemist does not have the same inspection needs as the ship inspector. The ship inspector often has to climb in closely spaced areas and has to move his head from side to side to inspect the structural areas. To improve the suitability of the system for tank structural inspections, the battery pack needs to be smaller. Also the light would need to be directionally adjustable, possibly remotely operated from the waist belt. It would also be helpful to be able to easily remove the lighting unit from the cap for hand held use.



Mine Safety Appliance Cap Lamp Lighting System

**Figure 4-4**

## 5. Access

A close-up survey (Table 1-1) requires that the inspector to be able to access the upper regions of the tank. However, survey requirements do not specify the method used to gain access to these internal structural members. In addition to the close-up survey required by the classification society, a thorough inspection is often conducted by the ship owner prior to entering the shipyard in order to prepare repair specifications. The methods used to gain access for these inspections vary in terms of effectiveness, time, and cost.

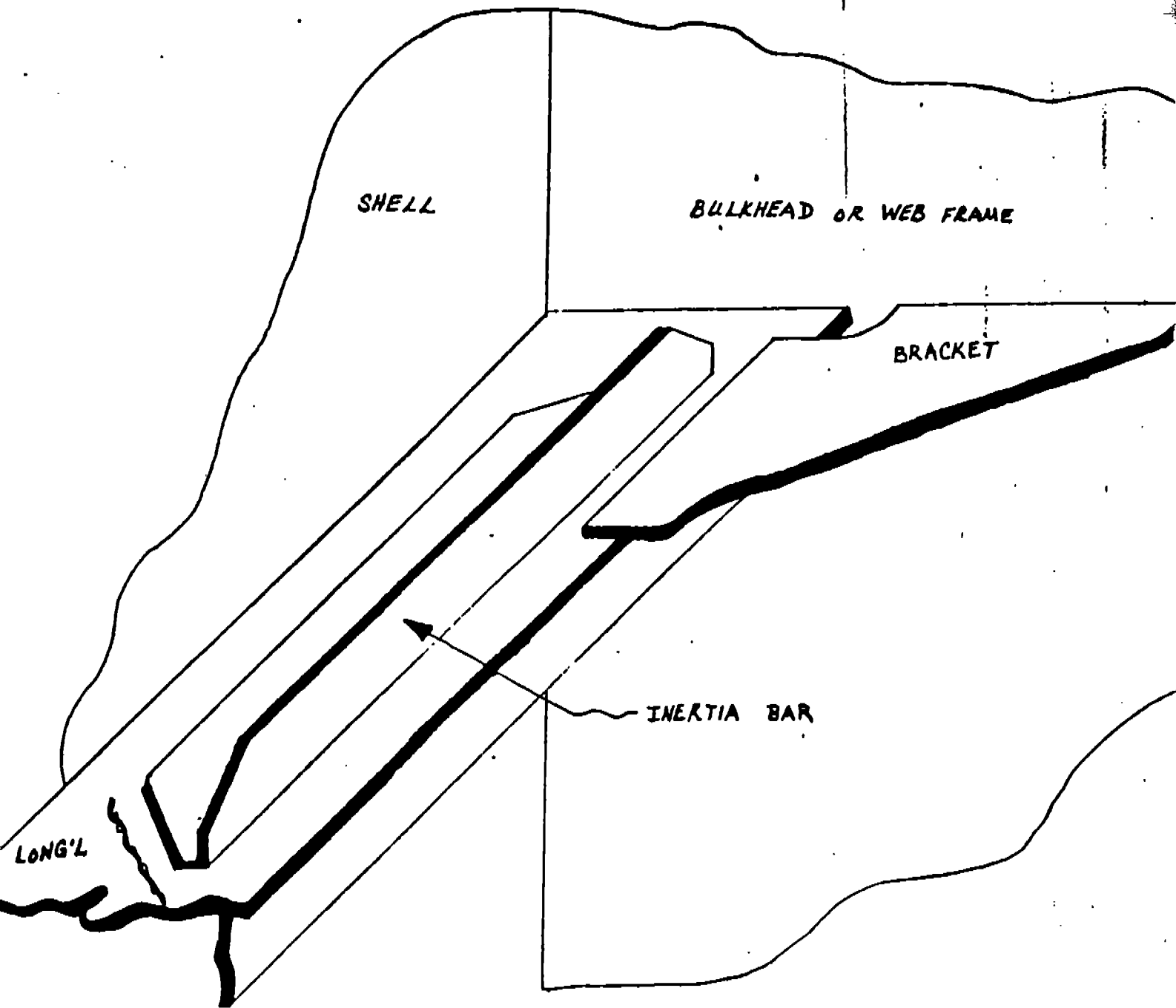
This chapter provides a qualitative analysis of four groups of methods to gain access to a tank. This chapter has been broken down into four sections. **5.1 Improved Tanker Design** discusses design features that, if incorporated, would improve accessibility for the inspector in the tank. **5.2 Access - Inspector in the Tank** deals with those methods that require the inspector to physically enter the tank for the inspection. **5.3 Access - Inspector Out of the Tank** discusses methods that allow the inspection to be conducted with the inspector outside the tank. And finally, **5.4 Access - New Technology** discusses those methods which to date have not been used for actual tank inspection, but merit further research. Table 5-1, immediately following section 5.4, summarizes the methods discussed.

## 5.1 Improved Tanker Design

Future tanker design is an important consideration for improved tanker inspections. Currently most vessels are only fitted with ladders to provide access to the tank bottom; some also have catwalks with handrails near the bottom running across the transverse web frames. It is interesting to note that during a survey conducted by Basar and Jovina [11], "In all of the five shipyards visited, the design departments did not consider the accessibility of the structures on the detailed drawings they prepared. This was left to the production departments to accomplish during actual construction. Yet, individual structural designers could assure proper access when developing the detailed plans by little extra effort. This would beneficially influence the overall effectiveness of inspection activities in that no changes to drawings and/or completed structures will be necessary in order to improve access and inspectability, and therefore result in cost and time savings."

In one design instance, improved access has been achieved accidentally. A tanker was experiencing cracking in the side longitudinals at the lapped flatbar bracket on the web frame. An inertia bar was welded onto the side longitudinal next to the bracket (Figure 5-1). This design change caused the cracking to occur further down the longitudinal near the end of the inertia bar. However, it also provided improved access to the longitudinal bulkhead. Inspectors have commented that these inertia bars makes the side longitudinals easier to climb.

Inspectors should not be required to make do with what is currently provided. A more proactive mode should be undertaken to provide the inspector with improved access through tanker design. Typical arrange-



Inertia Bar  
Figure 5-1



ments today only provide access to a very limited portion of the tank (bottom and stringer platforms). Additional walkways and ladders could be fitted to provide the inspector increased inspection coverage. Some ships have permanently installed ladders only on the forward or aft stringers, making the opposite side of the tank and transverse bulkhead inaccessible. Often, minor cracks are found on these stringer platforms. On the side where ladders are not present, staging is set up for repairs and inspection at a significant cost. Figure 5-8 (Section 5.2.5) shows staging erected alongside the forward stringer platforms on the M/T Golden Gate while the vessel was in drydock during the summer of 1991. This staging was erected to provide access for inspection and light repairs. Had permanent ladders been installed, this staging would have been unnecessary. Over the life of the ship it often would prove to be more cost effective to have a permanently installed ladder to gain access to the stringer platforms rather than stage this area for inspection accessibility and minor repairs.

The main reason owners resist fitting vessels with these additional structures is the added tonnage and the additional maintenance requirements associated with these arrangements. However, this may be a small price to pay as compared to a crack that may go unnoticed. The thoroughness of the inspection is often limited by the means with which tank access is provided onboard the vessel. During the life of the vessel, additional ladders and walkways may prove to be more economical than temporary staging that is erected in order to provide access for repairs and inspections.

Possible methods of improving access can be broken into two categories: those methods that are relatively minor in nature that do not sig-

nificantly affect the structural design and those methods that may significantly affect the structural design.

Those methods that do not significantly affect the structural design include;

1. Fitting permanent walkways and ladders at strategic locations within tank, particularly walkways below the overhead and ladders along the transverse web frames (Figure 5-2).
2. Attaching permanent clips or lugs on the internal structural members for use of temporary staging, or for attaching ropes or retractable lifelines for use during an inspection.
3. Installation of both forward and aft ladders to access stringers (if not already fitted).
4. Investigation of alternative materials for ladders, such as fiberglass, to eliminate corrosion problems and thus eliminate maintenance problems.
5. Additional installation of handholds to provide access to critical structural members. This may avoid the need for costly staging during inspections.
6. Use of lighter coatings in ballast tanks. Lighter coatings provide an easier means to detect cracks which produce rust streaks and discoloration.
7. Provide handholds in the underdeck transverse web frames.

When rafting is conducted the tank is ballasted to within one meter of the underdeck transverse web frame. This can leave the inspector several meters away from the underdeck connections. By providing a means to climb to the overhead from the raft, close up inspection is assured.

Those methods that may significantly affect the structural design include;

1. Installation of extended longitudinals every fourth or fifth longitudinal or at a very minimum in the upper most region of the tank to act as walkways for the inspector (Figure 5-3). These walkways should be fitted with handrails or a similar arrangement to which the inspector can clip into with a safety harness. Safety harnesses should become standard operating equipment for the inspector when the inspection is conducted above the tank bottom. An extended longitudinal in the upper region of the tank would work particularly well with the use of an ascender as discussed in the Section 5.2.3 of this report. The inspector would use the extended longitudinal as a platform from which he/she would be lowered to inspect the side structural members. Extended longitudinals will more than likely impair the tank cleaning process. Additionally, they may also introduce unwanted structural detail when carried through the transverse web frames [9]. With an extended longitudinal in only the uppermost region, these disadvantages would be minimized.
2. Increased spacing of structural members in certain limited space areas to facilitate ease of access. Not all inspectors have small framed bodies.
3. Avoiding blind spots in structural members where visual inspection without the use of mirrors is difficult. This will also facilitate repair work involving welding.
4. Providing permanently installed access plates or holes for entering tightly arranged structures.
5. Reconfigure underdeck longitudinals so that they are on the tank

top (Figure 5-4).

6. Tank hatch openings with limited ladder access should be included in each bay between transverse web frames . This would allow the tanks to be ballasted beyond the one meter below underdeck transverse web frames limit and allow for close up inspection of the underdeck longitudinals.

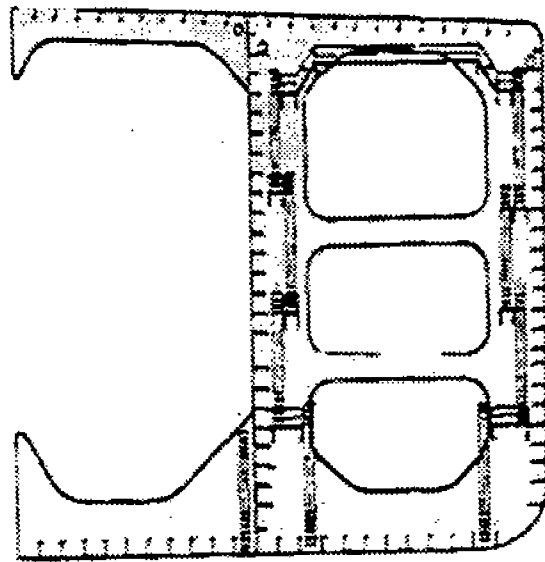
The construction of double hull tankers as require by the Oil Pollution Act of 1990 will, by its very nature, improve access-providing there is adequate clearance in the wing and double bottom tanks. A minimum of 2 meters and maximum of 3 meters is recommended. However, there will still be a need for improved access. One of the longitudinal bulkheads in the centerline tanks will still have longitudinal stiffeners. Some means to gain access such as rafting or portable staging will still be required.

When considering alternative designs for improved access, the ability to adequately clean a tank must be considered. Designs such as extended longitudinals may decrease the ability to adequately clean a tank. It is imperative that a tank be clean in order that an effective inspection be conducted.

Additional research is being conducted to determine critical structural areas that warrant closer and more frequent inspections [4]. These areas should be considered when designing increased access for the inspector.

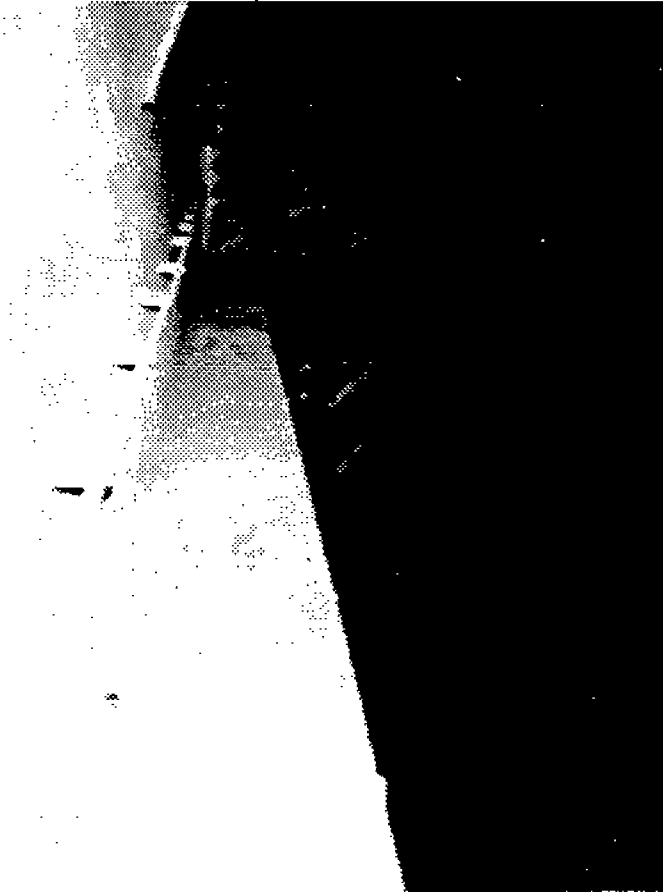
It will be difficult to determine the costs and benefits associated with these measures. Down-time from injuries is costly and ultimately an inspector's life is priceless. Although ship owners resist major modifica-

tions to the tank for the sole purpose of inspectability, minor modifications that can be installed on existing ships as well as new construction will be an improvement over the current arrangements for tank access. Although improved design may involve increased costs, ship weight, and maintenance, the benefits due to increased accessibility and safety may prove to be worthwhile.



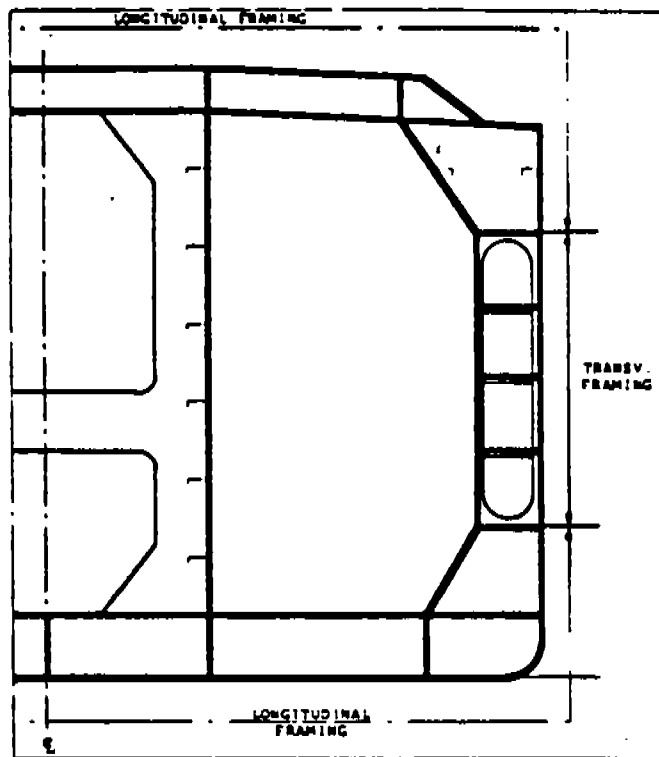
Ladders along Transverse Web Frames

**Figure 5-2**



Extended Longitudinal

**Figure 5-3**



Possible Double Hull Configuration which would Permit Improved Access

Reproduced from: "Some Considerations Regarding Tank Inspection Priorities For Oil Tankers" [14]

Reconfigured Underdeck Longitudinals  
Figure 5-4

## **5.2 Access - Inspector in the Tank**

This section describes those methods that require the inspector to be in the tank in order to conduct the inspection.

### **5.2.1 Close Up Inspection of Accessible Structure Without Climbing ("Walking the Bottom")**

This method consists of walking the bottom of the ballast or cargo tank area. Often this method is used as a first step in inspecting the tank. Walking the bottom allows for close up visual inspection by all members in the inspection party, permits a detailed documentation of the survey, and requires no set up time or equipment prior to the inspection. The inspector also has access to the stringer platforms (horizontal girders) when ladders are present (See Appendix D). Stringer spacing has a direct affect on the ability to conduct a close up survey of the underdeck stiffeners on the stringer platform. The stringer platform spacing can range from approximately 10 to 25 ft. When the spacing of platforms exceeds 10 ft, the use of a portable ladder to inspect the underdeck stiffeners on the stringer platform should be considered.

A disadvantage of "walking the bottom" is that the survey is restricted to the lower region of the tank. Some ships have permanently installed ladders on only the forward or aft stringers, making the opposite side of the tank and transverse bulkhead inaccessible. Another major disadvantage of this method is that the inspector only has line of sight view and usually part of the structure is hidden from view. The lack of hands-on access to structural members may also seriously hinder the quality of the inspection. In cargo tanks, the inspector often needs to scrape away oil residue for an improved view of the welded members. In ballast tanks the inspector will



chip away rust layers to determine the extent of localized corrosion.

Walking the bottom does not allow the inspector this freedom except on the tank bottom.

### **5.2.2 Physical Climbing Without Restraint**

This method consists of climbing the side structural members without the aid of fall safety devices. Often the inspector will use the side longitudinals as a ladder to gain access to upper regions of the tank (Figure 5-5). Most company policies recommend that climbing height not exceed 3 meters. Above this height safety is compromised and climbing should not be allowed. Even at a height of 3 meters, a fall could cause serious, if not fatal, injury. Although from Figure 5-5 it is not evident, this inspector is climbing the side longitudinals at the outer edge of a stringer platform. This inspector was placing himself in a potentially life threatening situation.

The inspector is required to determine the structural integrity of the vessel and certify that the vessel is safe for the route intended. Although an inspector is never forced to work in an unsafe situation, rather than cause the vessel to become involved in unnecessary delays, the inspector may feel pressured to push the envelope of safety. For this very reason, a concerted effort must be made to investigate alternative methods to gain access to the upper structural members within the tank.

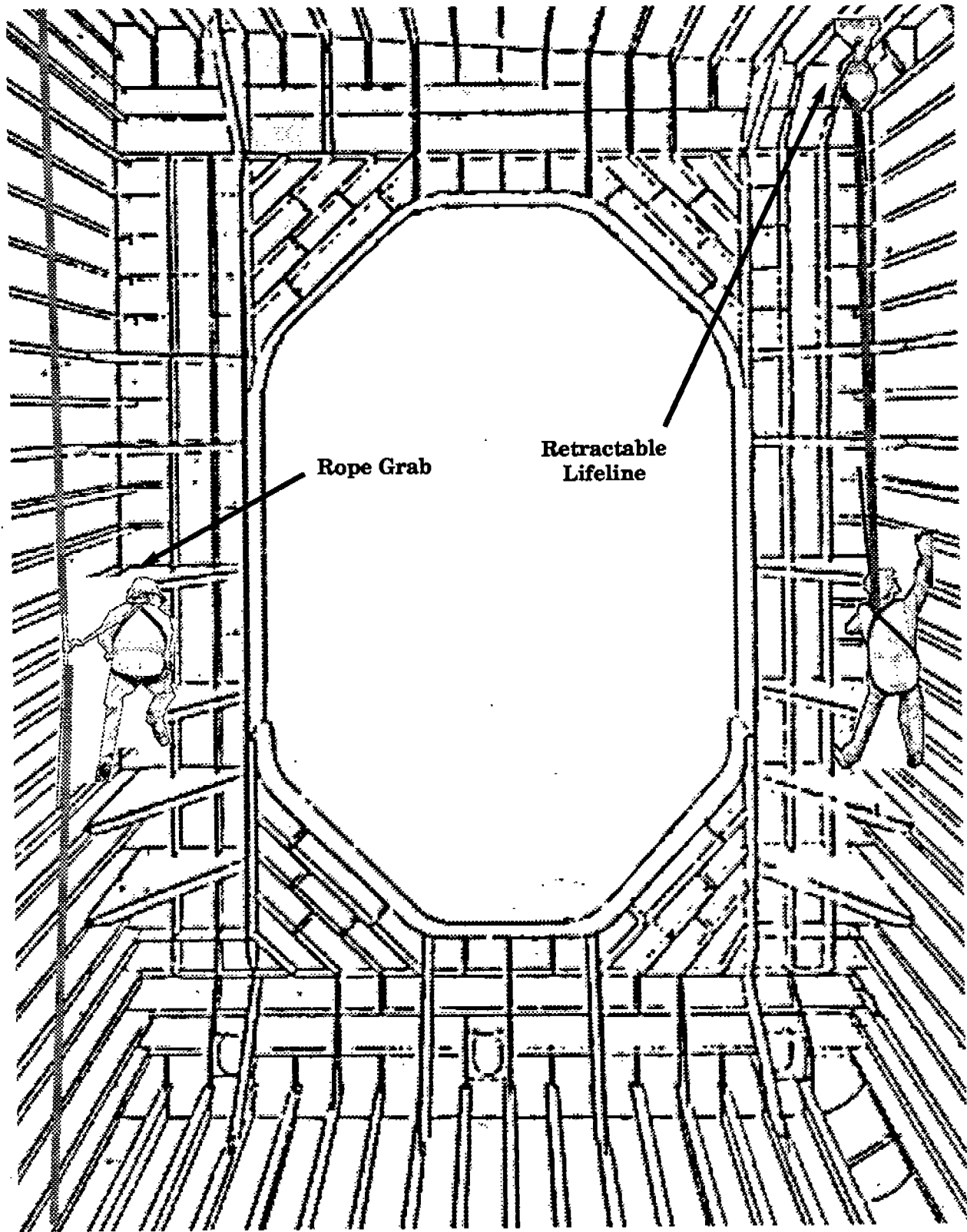


Inspector Climbing Side Longitudinals

**Figure 5-5**

### **5.2.3 Physical Climbing with Fall Safety Devices**

This method consists of physically climbing the side structural members with the use of a fall safety device. The basic concept is to clip a rope to one of the upper side longitudinals. From the bottom of the tank the inspector will clip himself onto the rope with a harness attached to his body and a specially designed rope grab clipped to the suspended rope (Figure 5-6). The inspector is now ready to begin climbing the longitudinals or other



Fall Safety Devices

Figure 5-6

structural members above the rope. Should the inspector fall the rope grab is designed to stop the inspector's descent. Another type of fall safety device is a retractable lifeline (Figure 5-6). The retracting lifeline pays out as an inspector ventures from the device. It has an instant locking feature that will stop an inspector's free fall.

Physical climbing with a fall safety device allows the inspector to safely inspect the sideshell and bulkhead areas when climbing, but the tank top area remains essentially inaccessible. These devices and method of inspection have a proven degree of safety.

The most difficult aspect of physical climbing with a fall safety device is the setup. Access must be provided to the upper side longitudinals so that the ropes may be installed for the inspection. This is easier said than done. Many cargo tanks and ballast tanks of today do not provide access to the top structural area. One method to gain access to the upper longitudinals is discussed in Section 5.1.8 (Portable Staging). Minor structural modifications to present and future tankers could allow easier access, making climbing with a fall safety device more attractive (See Section 5.4 Improved Tanker Design).

When climbing with safety devices the inspector must not venture to either side of the line. If the inspector ventures too far from directly underneath the rope and falls, a pendulum effect takes place with the possibility of the inspector striking a steel member on the opposite side of the pendulum swing.

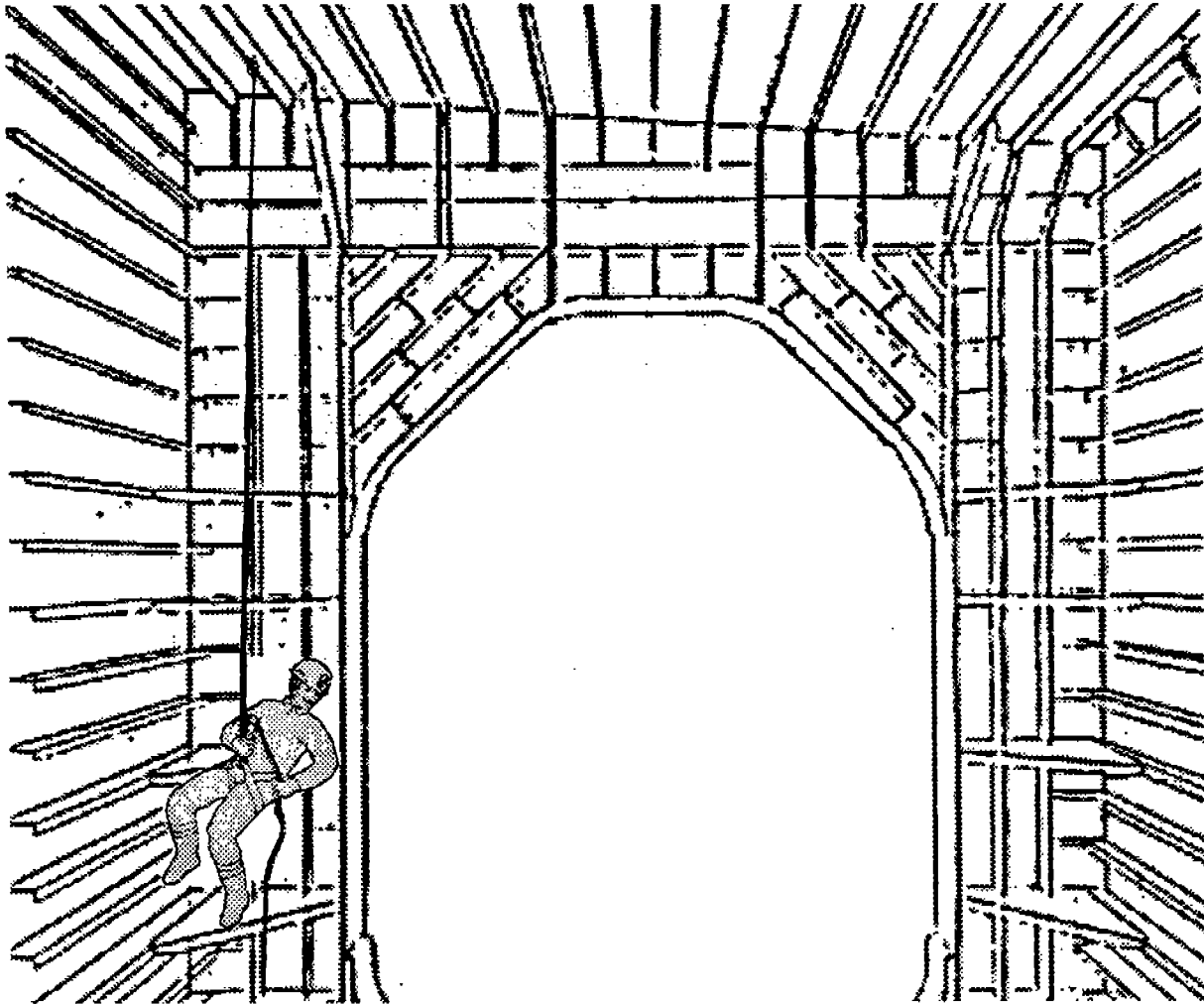
Climbing can be physically demanding. It can be difficult to record the findings while holding onto the side longitudinals. Having a designat-

ed individual below to record the findings can help eliminate this problem. However, voice communications can be difficult, particularly when those in the tank are required to wear filter half masks and hearing protection.

Due to the physically demanding nature of climbing with safety devices, any use of fall safety devices would be most attractive for inspecting specific problem areas. For example, inspection of a particular problem area midway up a deep web frame could be easily accomplished with this method. When only a critical area needs to be inspected, physical climbing with a fall safety device may be better than the rafting method discussed in section 5.4.6.

#### **5.2.4 Access to Side Members With Ascender**

This is a variation of physical climbing with fall safety devices. The idea is to use an ascender so that the inspector can lower himself down the side of the tank (Figure 5-7). An ascender is often used in rock climbing when the climber wishes to descend down the side of a face. This method is less physically demanding than climbing and hands free operation is possible, allowing the inspector to record information. Some training is required for the inspector before using this system. As with the physical climbing with fall safety device method, clipping the rope into the tank top area presents a problem.



Ascender

**Figure 5-7**

### **5.2.5 Fixed Staging**

Fixed staging consists of portable bars and platforms that can be erected inside a tank. Figure 5-8 shows staging erected alongside the forward stringer platforms on the M/T Golden Gate while the vessel was in drydock during the summer of 1991. Staging allows for subsequent repairs and follow up inspection of the repair work. Some companies selectively stage certain tanks if there are known problem areas or when required for



Fixed Staging

Figure 5-8

an ABS close up survey

Fixed staging is one of the preferred methods for the inspector. With staging, close up inspection of all parts of the tank by all members of the inspection party is possible. However, the use of staging is limited to the repair yard. This method would not be available for a survey at sea for preparation of repair specifications. Complete staging of all tanks is both cost and time prohibitive.

### **5.2.6 Rafting**

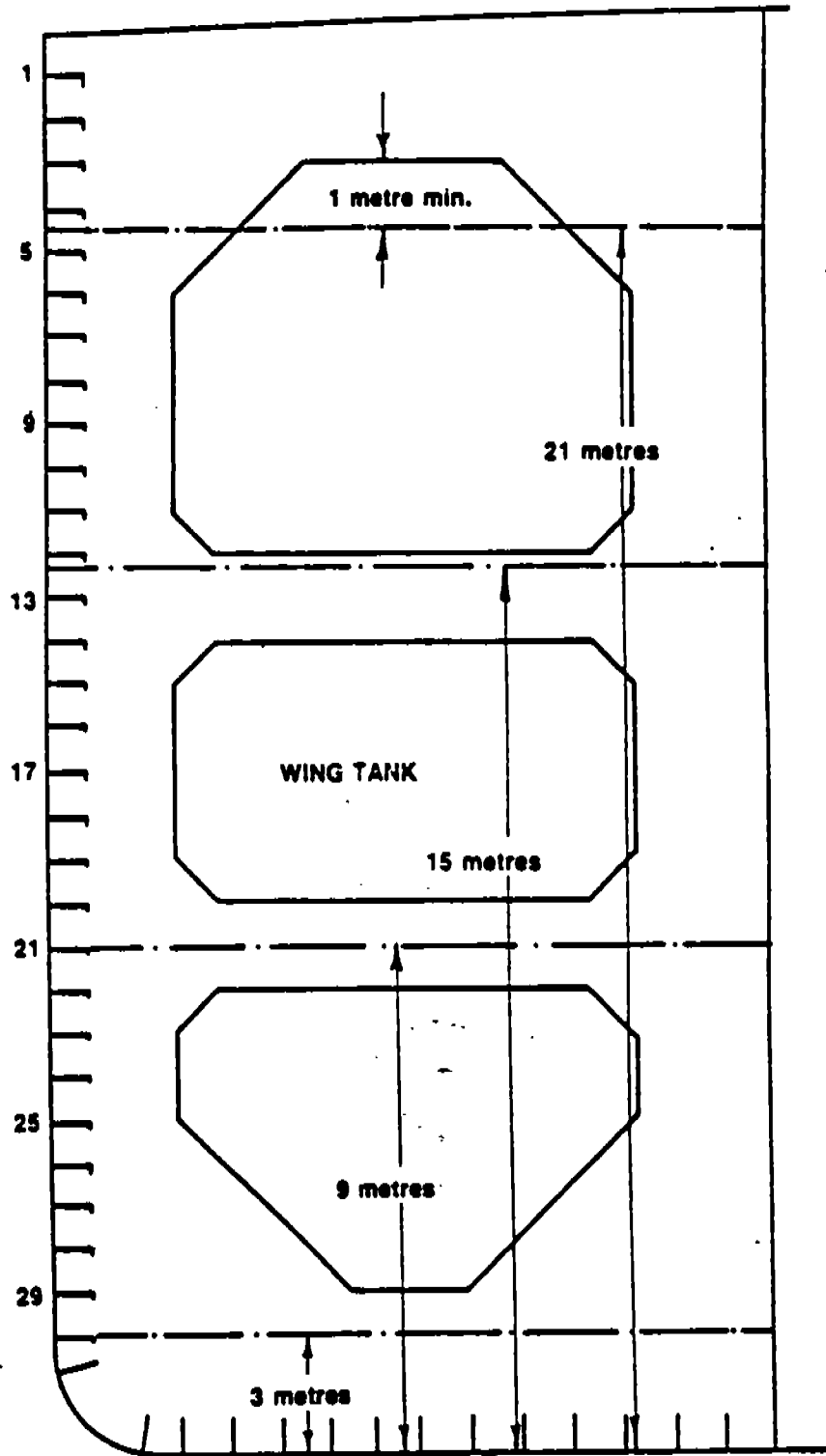
Rafting is one of the more common methods used to survey a tank prior to entering the yard. The rafting method consists of inspectors (usually two), canvassing the perimeter of a partially ballasted tank in an inflatable rubber raft. The tank is filled with ballast water to three or four different levels (Figure 5-9). At each level, the survey team paddles along the perimeter of the tank (Figure 5-10). The tank can be ballasted to the same level as the cross beam to damp the wave motion in the tank. This may be necessary if the vessel is experiencing movement due to sea conditions. However, moving the raft from bay to bay may prove to be difficult and should be considered before ballasting to these levels. Where a swash bulkhead is provided, the two ends of the tank should have their own deck hatch and ladders to allow for escape.

The raft should be of heavy construction with dual chambers with a rope grab along the entire perimeter of the raft. Acceptable vendors include West Marine, Avon, Dunlop, and Zodiac [31]. The individuals in the boat must at all times be wearing a Type III personal flotation device (PFD). The tank should never be filled closer than one meter to the deck transverse so that the survey team is still provided with an escape route. Also, when ballasting the tank, care should be taken so as to not overstress the tanks. Standard operating procedures should apply. If an inert gas system is installed onboard the vessel, the system should be isolated so that no gases are capable of entering the tank.

Rafting allows close up inspection of all members with the exception of the overhead. Limited climbing is possible due to the water cushion, but the inspector should not climb more than 6 meters above the water cushion (Figure 5-11).



# TYPICAL BALLAST LEVELS SKETCH FOR 250 KDWT VLCC



Source: "Inspection  
Procedures and Their  
Influence On Tanker  
Design" [9]

Figure 5-9



Rafting  
**Figure 5-10**

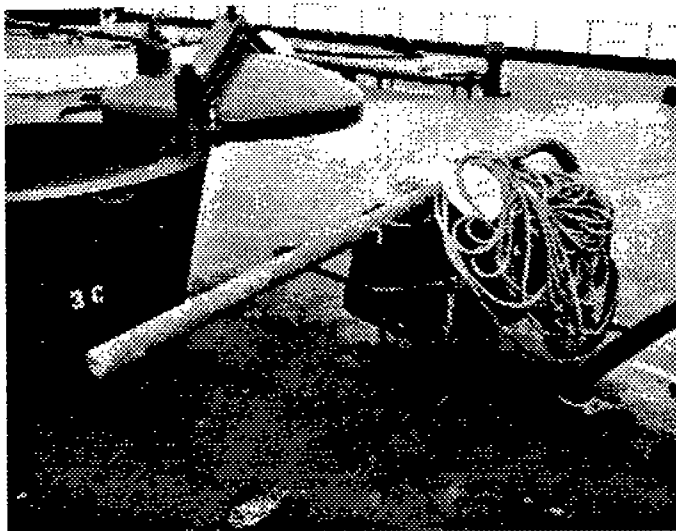
The Chief Mate is typically responsible for insuring the tank is safe for personnel entry. During rough seas, rafting surveys should be suspended for safety considerations. Typically more than a couple of degrees of roll or sloshing of the tank of more than one meter is enough to suspend operations. Hence, weather can delay or preclude the use of this method when the vessel is underway.

Exxon Corporation has published for their fleet a set of safety procedures for rafting [31]. In addition to the above mentioned safety procedures, they require the presence of two additional people, dedicated on-deck and in-tank spotters (Figure 5-12). The in-tank spotter is required to be in constant radio communication with the on-deck spotter. A dedicated emergency equipment cart including Emergency Escape Breathing Apparatus and Stokes litter for emergency escape rescue operations is placed at each tank opening through which rafting operations are conduct-



Climbing During Rafting

**Figure 5-11**



Emergency Escape Equipment



On-Deck Spotter

**Figure 5-12**

ed (Figure 5-12). A record of all personnel entering and leaving each tank is maintained.

An in depth rafting survey can take 15 to 20 days, resulting in considerable out of service costs. Moving ballast takes time and fuel costs associated with transferring the ballast water run anywhere from ten to fifteen thousand dollars per ship inspection. [9]

The rafting inspection is usually conducted outside the shipyard and tank entry is often conducted without a marine chemist certificate. With the new benzene exposure limits required prior to tank entry, many ships do not contain the equipment required to test for benzene exposure limits. This has raised concern by U.S. Coast Guard inspectors when attending these rafting surveys. Although many companies believe that this method is the best way to conduct a survey prior to entering the shipyard, other companies believe it is inherently unsafe and therefore do not use rafts to conduct the survey. This method also hinders the movement of the inspector due to the PFD requirement.

### **5.2.7 Binoculars with High Intensity Light**

This method incorporates the use of binoculars or a low powered telescope mounted on a tripod and a high intensity light that is usually powered from a 220V source and is typically not intrinsically safe. The use of non intrinsically safe equipment should be limited to tanks that have been certified safe for hot work by a certified marine chemist. Very little set up time is required for this method. The inspector conducts the survey from the bottom of the tank and uses his experience to determine which areas to view.

As with the "Walking the Bottom" method, the major disadvantage

with this method is that the inspector only has line of sight view and usually part of the structure is hidden from view. Additionally, the inspector is not able to chip away at rust or scrape away oil residue buildup.

### **5.2.8 Portable Staging ("Spider")**

This method uses a portable staging device such as the mini-spider manufactured by the Spider Staging Corporation. It works and looks much the same as a window washer device used on tall skyscrapers and easily disassembles so that access through a manhole is possible (Figure 5-13). The unit is set up so that tank walls are easily accessible and inspectable (Figure 5-14). The Spider can be configured to carry between one and four people. It is air powered and explosion proof, making application to tank inspection particularly appealing. The unit may be manually lowered should air power fail. Inspectors must be attached to an independent lifeline as a safety precaution.

As with climbing with a fall safety device, the main difficulty associated with portable staging is the initial rigging. Before the unit can be used, cables must be attached to the overhead along the sides. One way to gain access to the underdeck longitudinals to install the cables is a method that is often used to install underdeck suspended staging; an individual walks himself across the underdeck longitudinals as shown in Figure 5-15. The individual wears a safety harness around the waist that is attached to the lines that are hooked into the underdeck longitudinals. Should the individual lose his grip, he is still secure. This technique is not for the faint of heart.

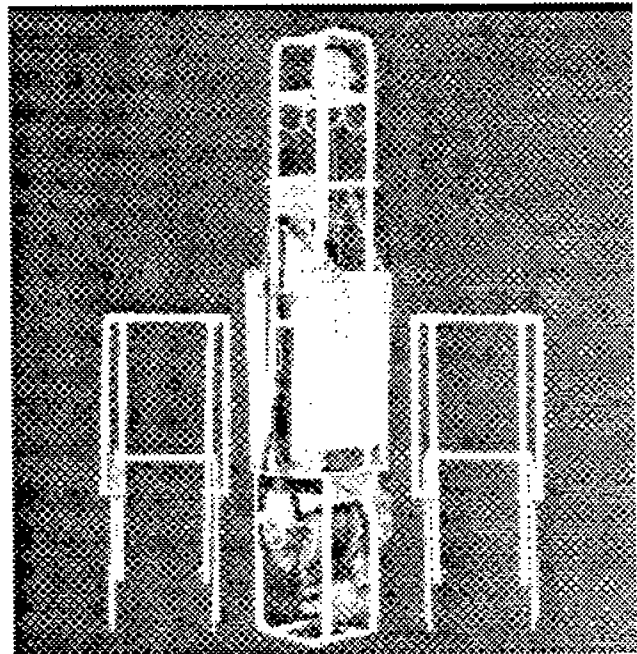
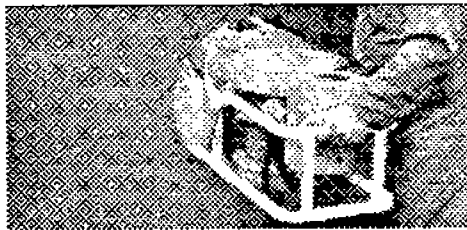
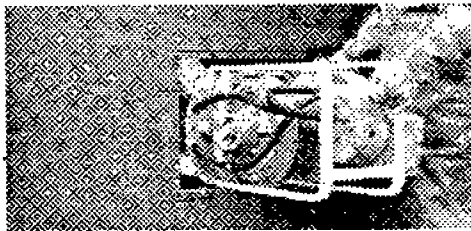
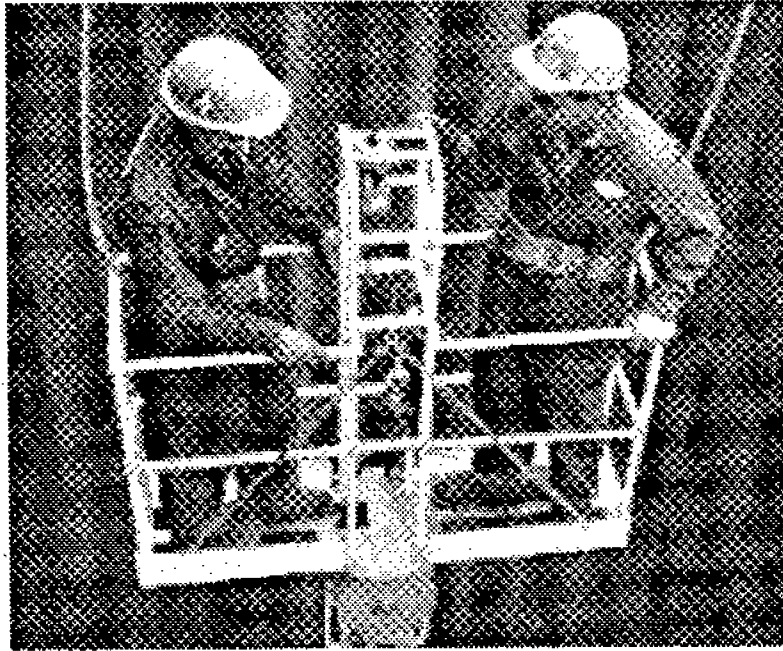
Stageaway Vessel Support Services. is currently marketing a pack-

age that will provide portable staging. Stageaway's package includes the total set up, break down and, in conjunction with Ronald Nisbet Assoc., the necessary or required inspection services. Stageaway employees will do the initial rigging and operation of the scaffolding for the inspection.

Stageaway's motto is "safety first". Unlike conventional underdeck suspended scaffolding that uses an "S" hook to attach to the underdeck longitudinals, Stageaway uses "U" hooks as seen in Figure 5-16. Figure 5-17 shows the "U" hook attached to the underdeck longitudinals. The cables are suspended from this "U" hook which then leads to the spider unit. Unlike "S" hooks, the "U" hooks are not able to become accidentally detached from the underdeck longitudinals.

Stageaway held a demonstration of their services aboard the M/T Thompson Pass on 22 August 1991. Photographs from this demonstration are included in Figures 5-18.

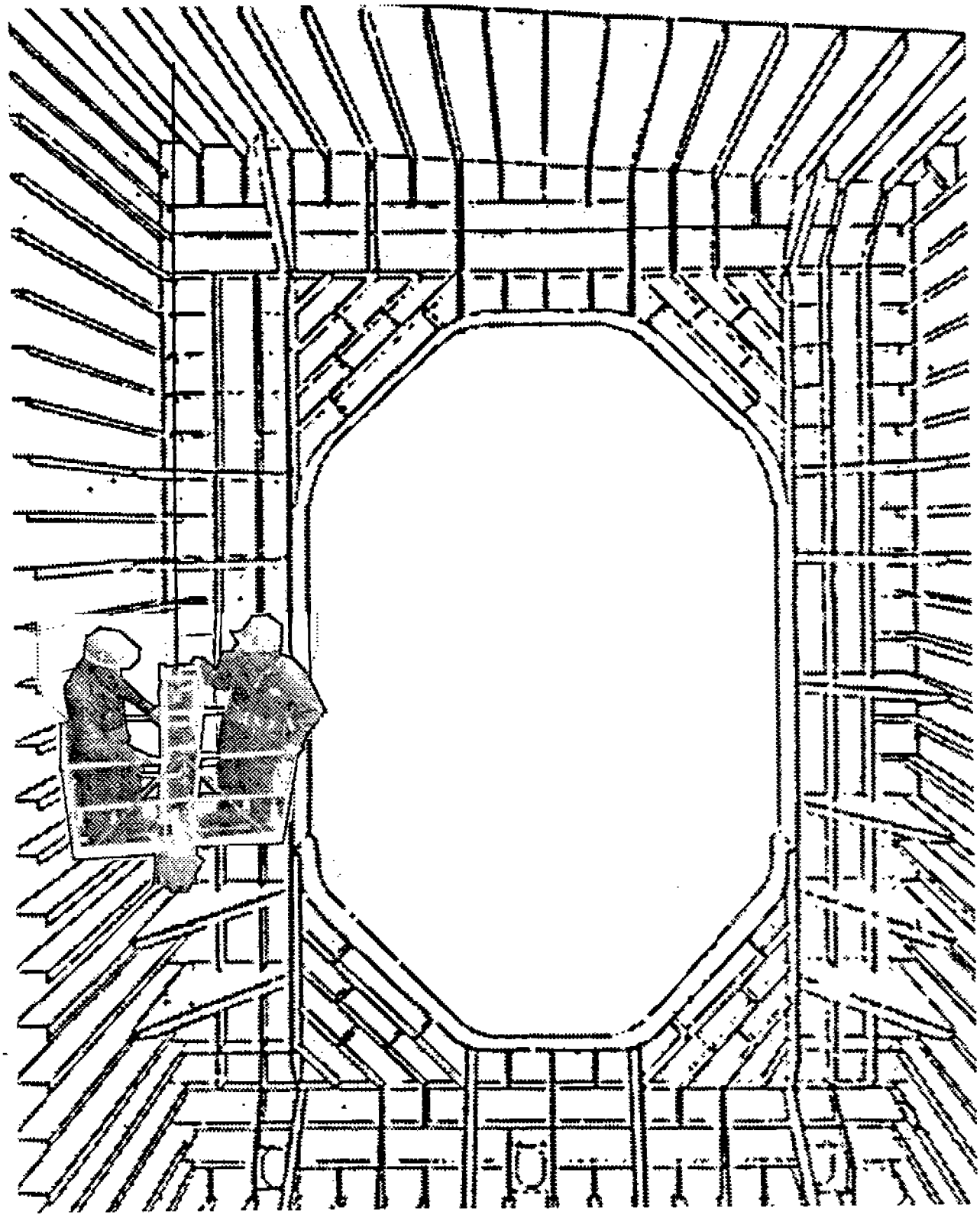
Also included with the Stageaway services is the capability of conducting light repairs. Stageaway has manufactured a portable fixed staging apparatus that can be placed along the side longitudinals where the repair is required (Figure 5-19). The spider is used to hoist the fixed staging to the desired location. From the portable fixed staging, light repairs may be conducted without the need for the Spider to remain in position. The portable fixed staging is particularly useful when only a few minor cracks are found along the side longitudinals. Small inserts are also possible with this setup. Portable fixed staging removes the requirement to construct permanent staging from the tank bottom. The Stageaway system in use with the portable fixed staging can be seen in Figure 5-20.



Source: Spider Staging Corporation  
information brochure.

### Spider Portable Staging

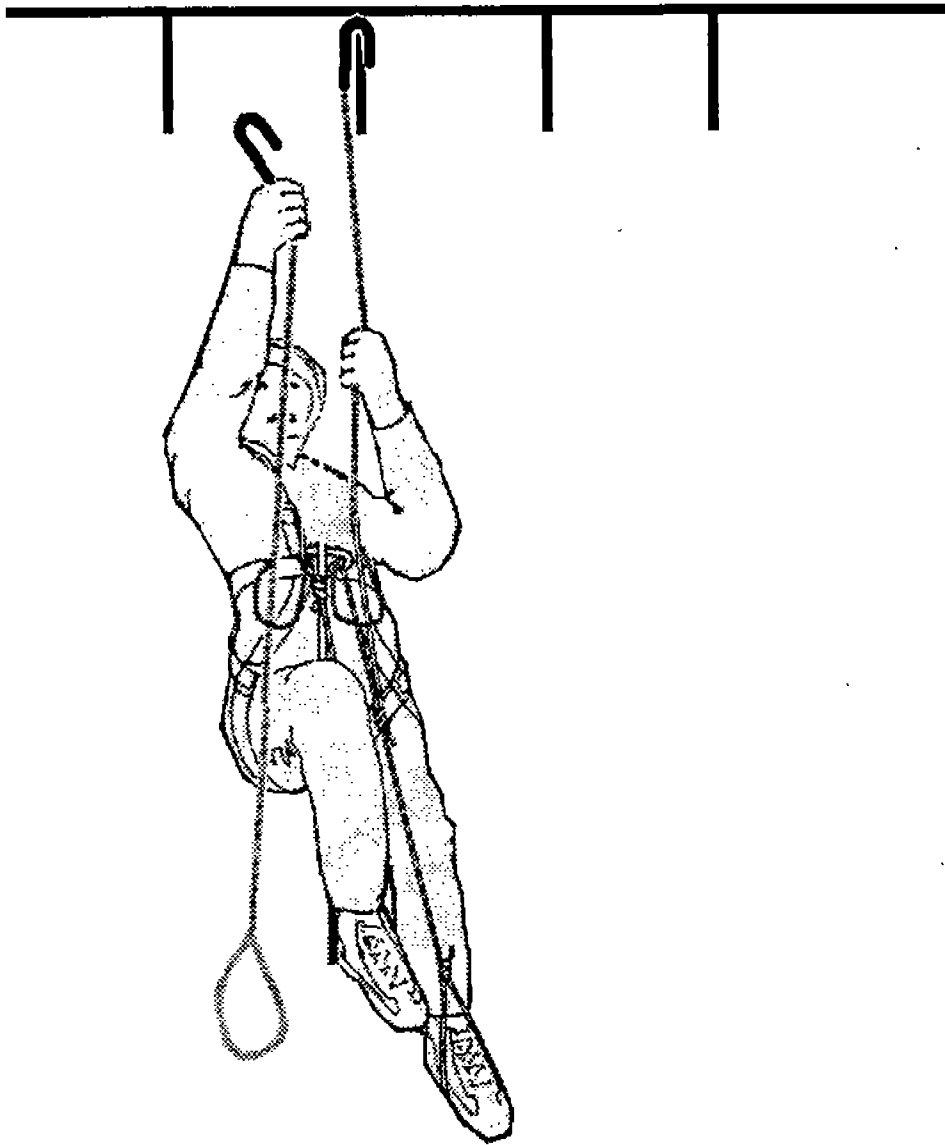
**Figure 5-13**



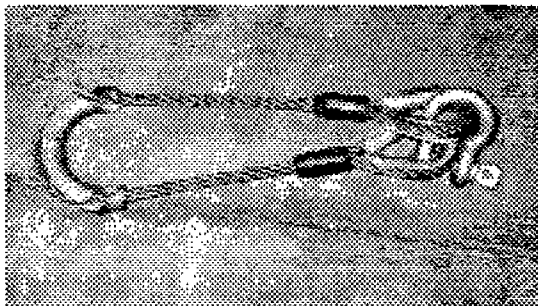
Spider Portable Staging in Tank

Figure 5-14





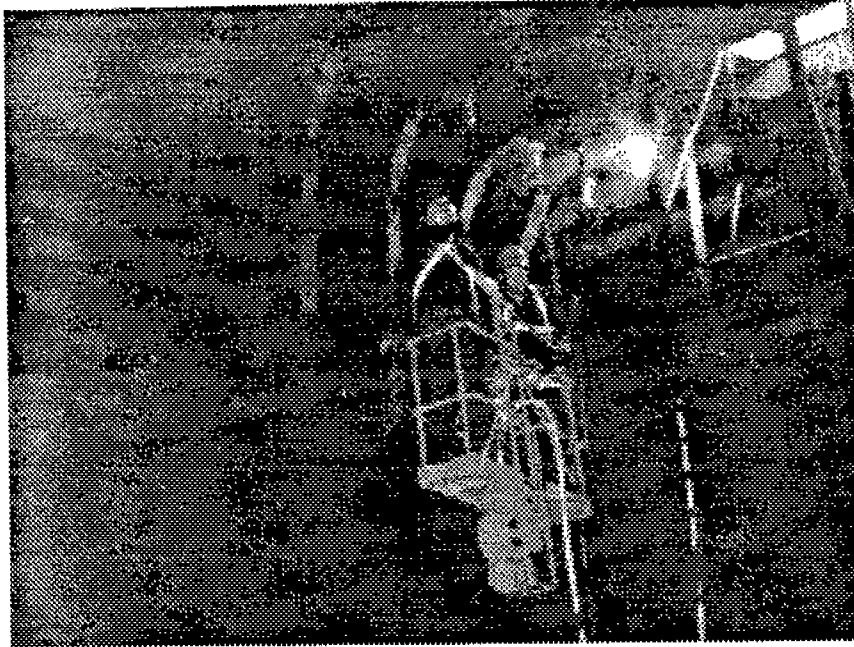
Access to Underdeck Longitudinals  
Figure 5-15



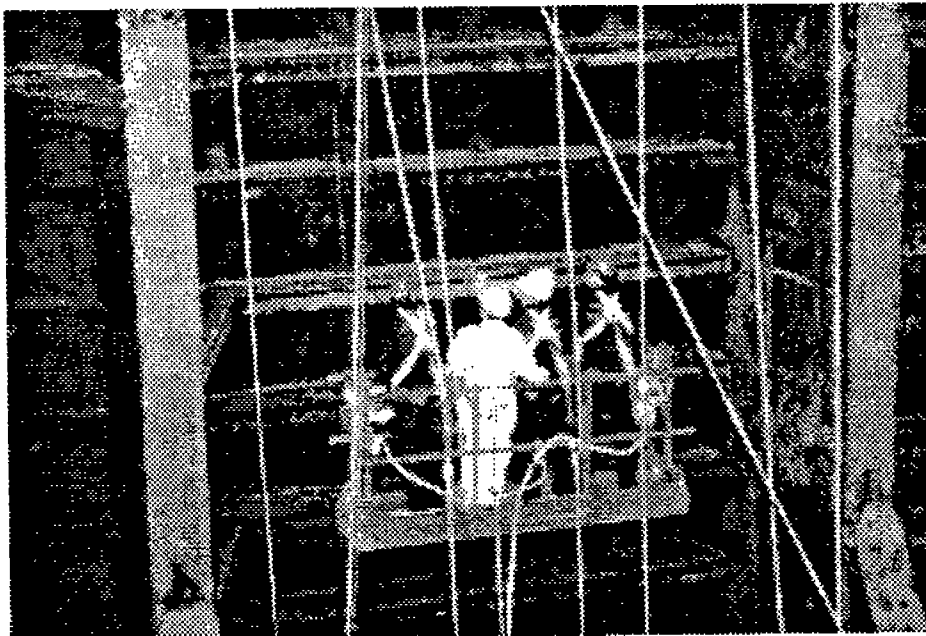
**"U" Hook**  
**Figure 5-16**



**"U" Hook Attached to**  
**Underdeck Longitudinal**  
**Figure 5-17**



**Two-Man Stageaway Inspecting Underdeck Longitudinal**



**Stageaway with four persons aboard**

**Stageaway Demonstration Onboard M/T**

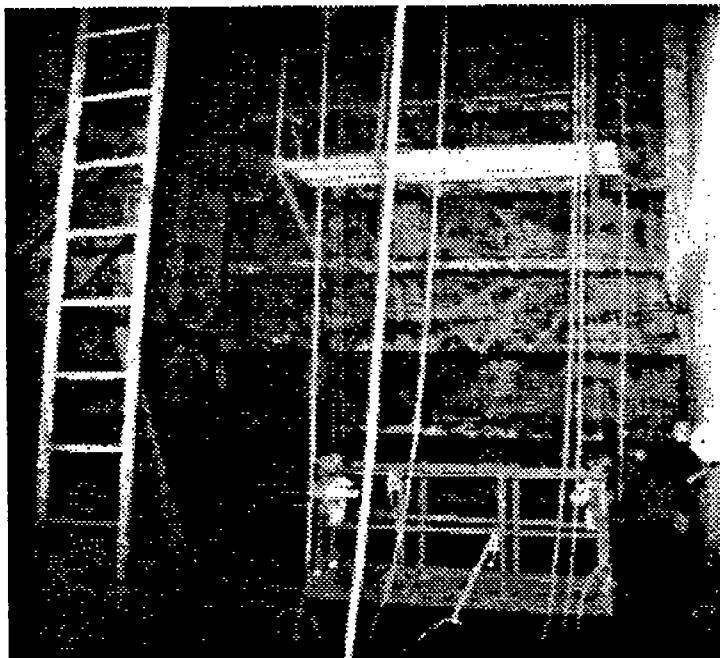
**Thompson Pass 22 August 1991**

**Figure 5-18**

220

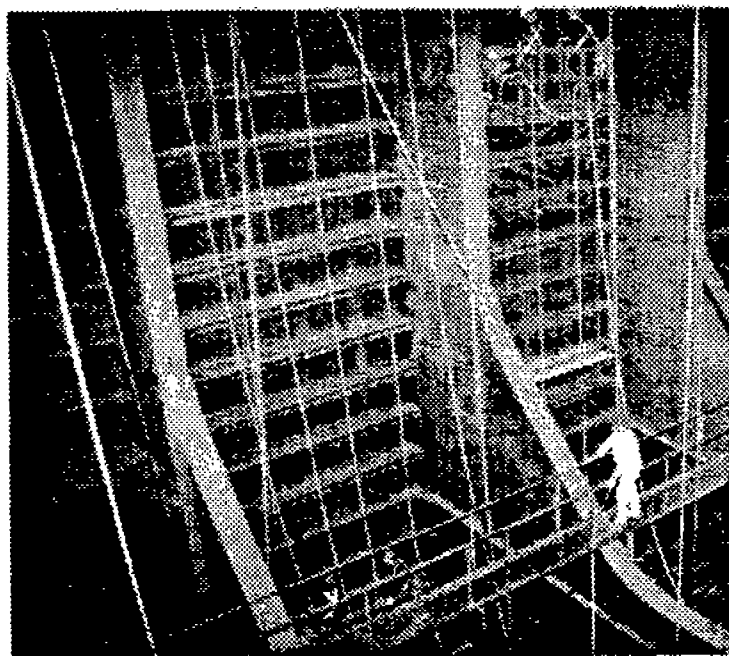


Portable Fixed Staging  
**Figure 5-19**



Stageaway System beneath the portable fixed staging. Stageaway System would be used to transport people up to the portable fixed staging.

Stageaway System to the extreme right - halfway up the bulkhead. Below that is a portable fixed staging and to the left of that is a Stageaway system about to commence an inspection.



Stageaway System In Use With The Portable Fixed Staging

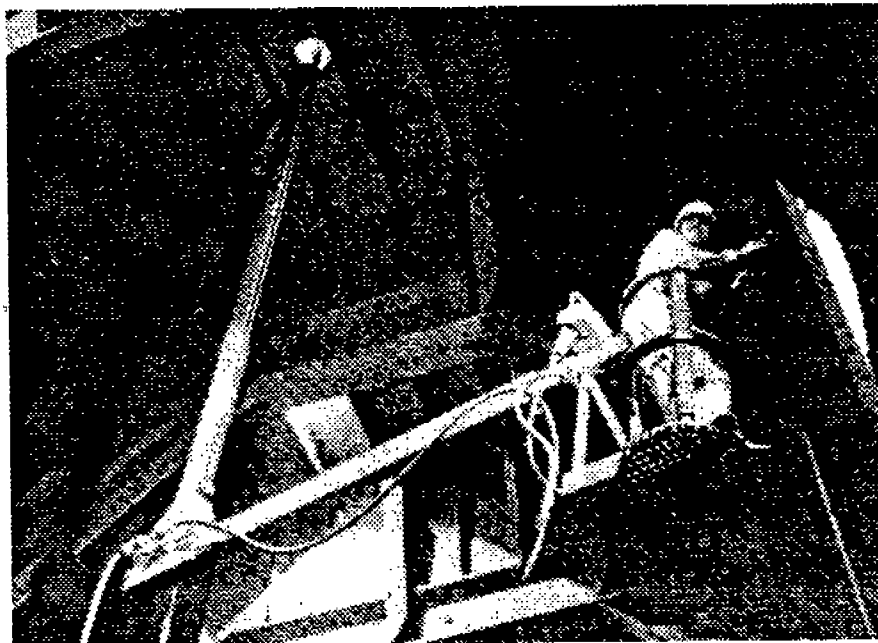
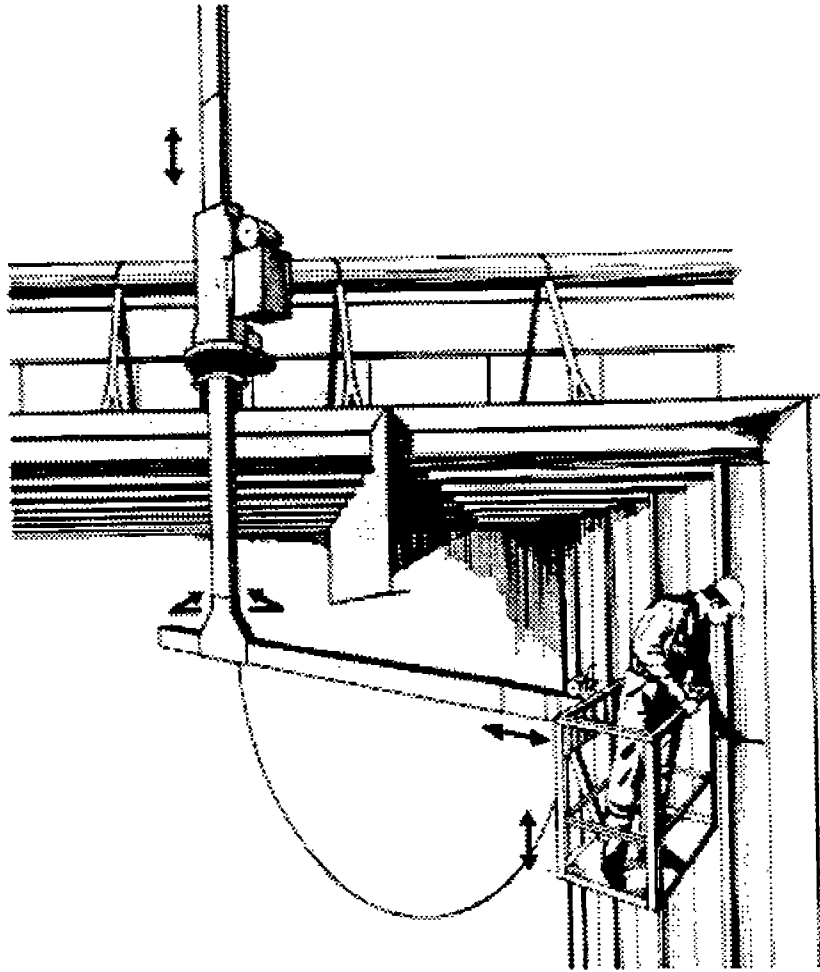
Figure 5-20

### 5.2.9 Mechanical Arm

A mechanical arm is a telescoping device that is lowered through a butterworth opening. At the end of the arm is a basket that is capable of carrying an inspector. From the basket, the inspector can inspect the sides and upper regions of the tank. One such mechanical arm has been developed by Sigval Bergesen in direct cooperation with Shell International Marine Ltd. of London. It is known as the Portable Work Platform or, more commonly, by its nickname in the field-"Ziggy". Ziggy is a pneumatically operated telescoping arm that is capable of fitting through a butterworth opening and is designed to carry one person (Figure 5-21). To assemble Ziggy in the tank, the motor section is first positioned over the opening, through which the vertical sections are then lowered. Each section weighs approximately 80 kg. Ziggy is capable of being used in tanks up to 25 m in height. The horizontal telescoping beam is fixed to the lowest vertical section. The operator's basket, which is affixed to the end, weighs approximately 50 kg. Total horizontal reach is approximately 8.5 m. Vertical movement of the basket is controlled from a control panel located at the operator's basket. The horizontal beam is shortened or lengthened by means of a hand operated winch.

Ziggy has been designed to be used in such applications as repairs, cleaning and inspections. Its pneumatic power and intrinsically safe design makes it particularly appealing to the tank environment. The apparatus is capable of being used at sea, but only during relatively calm weather. It has proven to be a good alternative to requiring the set up of expensive scaffolding. The major disadvantage with this apparatus is the set up time required prior to commencing the inspection. The manufacturer states that the device is capable of moving from one opening to the next

in approximately 4.5 hours. To conduct an entire ship inspection with this device would require an inordinate amount of set up and break down time. However, critical area inspections could be carried out with the Portable Work Platform. This device would seem to be obsolete with the introduction of the portable scaffolding method described in Section 5.2.8.



Portable Work Platform "Ziggy"

Figure 5-21



### **5.3 Access - Inspector Out of the Tank**

This section discusses those methods that allow for the inspection to be conducted with the inspector/surveyor outside the tank.

#### **5.3.1 Divers**

The use of divers for ship inspections has been successful for underwater hull surveys in lieu of a drydock examination. This method has the most success when the clarity of the water is high-such as in the Caribbean. Transferring this method to internal inspections leads to problems due to the turbidity of the water. In addition, the hull survey is a much simpler survey than an internal structural survey. The hull survey basically consists of inspecting flat plating. The internal survey is more involved due to the intricacy of the structural members.

A major difficulty the divers may confront is that the umbilical cord leading ondeck may become entangled in the structural members. In addition, when access to the tank is through the butterworth opening, the diver will have difficulty fitting through the limited size of the opening (Figure 5-23)

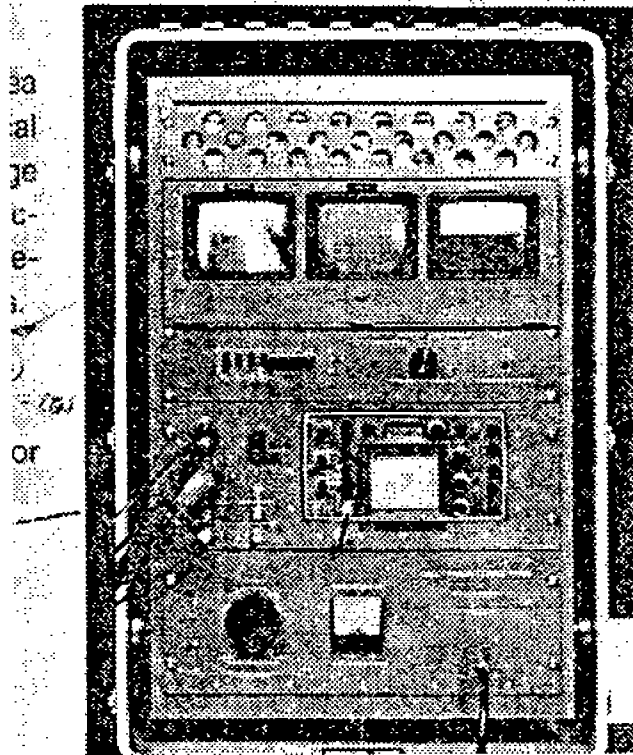
Divers can be used to conduct survey when the ship is in a ballast condition. In order for an internal inspection with the use of divers to be successful the diver needs to have some basic knowledge of tank configuration and ship structure nomenclature. However, typically the diver is inexperienced in conducting ship surveys and is therefore given a videocamera so that inspectors on deck can view the inspection.

Two divers should be used to conduct the survey for safety purposes. Since a diver's time is limited, and a large area must be inspected, one diver is impractical. Two divers are often used, taking turns diving the tank. When not diving, the second diver usually remains on deck for emer-

gency rescue purposes. Due to the fact that dives beyond a depth of 10 meters are required, the duration of the dive is limited (often less than 30 minutes). After one deep water dive, the diver is often prohibited from making additional dives that day. The location of the closest decompression equipment should be considered. Transportable decompression chambers that can be placed onboard the vessel if necessary are also available.

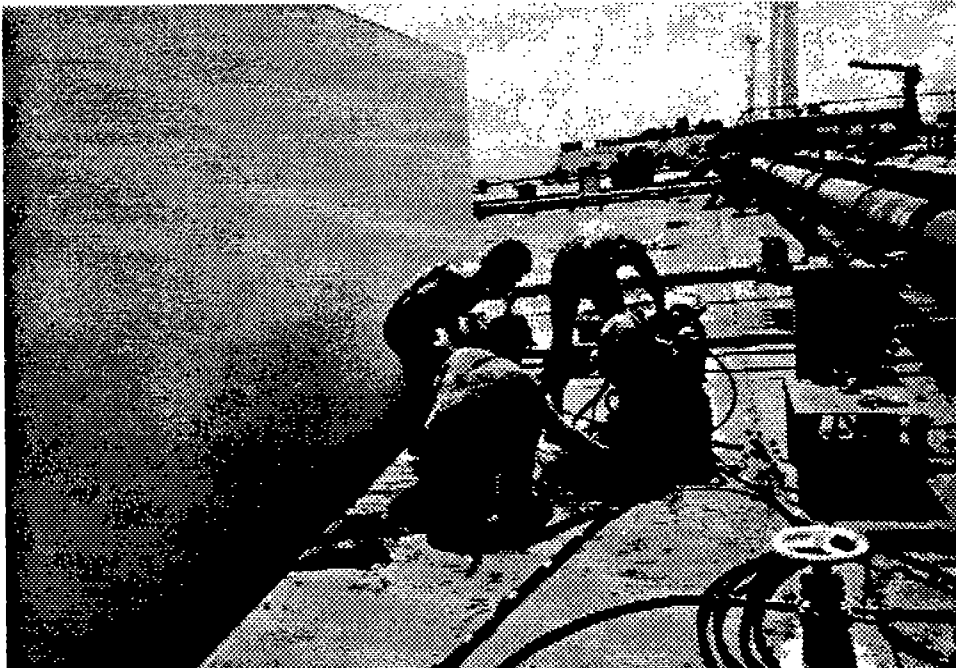
As with rafting, the ship should be ballasted so as to not overstress the hull. The use of divers also requires the Inert Gas System (IGS) to be isolated if onboard the vessel. Use of the video camera allows for good documentation of the survey. However, clarity of the ballast water has a direct affect on the quality of the inspection. The diver is also capable of carrying ultrasonic probes for thickness measurements.

An example of a video system that may be used for underwater internal tank inspection is the Ultrascan III manufactured by S&H Diving Corporation (Figure 5-22). The system consists of a control console, the diver's helmet with a monitor, camera and lights, and an umbilical connecting the diver helmet to the console. The system allows for two way communication between the diver and topside personnel. All controls are topside so that the diver's hands are free to perform his work. The inspector monitors the diver and controls the equipment from the control station outside the tank. Good communication between the diver and topside inspectors is important. A permanent video record can be obtained of the inspection.



Ultrascan III

Figure 5-22



Diver entering through butterworth opening

Figure 5-23

### **5.3.2 Remotely Operated Vehicles (ROVs)**

Remotely Operated Vehicles (ROVs) can be used for the inspection of ballasted tanks. The ROV can be fitted with a color camera, a surface cleaning device, and an ultrasonic measurement system for plate thickness measurements. The ROV and associated equipment must be intrinsically safe unless the tank has been certified safe for hot work. The effectiveness of the ROV in the ballasted tank is dependent on the water clarity and the cleanliness of the structural surfaces. The use of the camera allows close-up inspection by the inspection team on deck. As with the diver, a permanent video record can be obtained of the inspection. The main advantage of the ROV is that the inspector, or other personnel, is out of the tank which eliminates all the hazards associated with confined space entry procedures. Additionally, when the equipment is intrinsically safe, the ROV removes the necessity of the costly tank cleaning and gas freeing procedures.

In 1984, Mobil Shipping sponsored a research project with the goal of developing an ROV system that would cost under \$200,000.00. The system was to be reliable and capable of being operated by personnel having skills equivalent to a typical VLCC crew. The intent was to accomplish an in-service inspection on an at-will basis, so that, in the course of several voyages, a VLCC would be completely inspected. Unfortunately, the cost of the system, with all the accessory items (ie; tracking system, state of the art ultrasonics, etc.) was significantly in excess of the goal, and the technology required to operate the system was beyond the skill level of the average tanker crew complement.

The program goal then became the development of an emergency response capability and the more limited market size drove the system cost

up. At that point, the decision was made not to complete the program. Since the time the project was terminated (1986), state of the art tracking systems, control electronics, ultrasonic sensors, and post processing software have all improved significantly. However, the above mentioned disadvantages still exist and until solutions are found the use of ROV for internal tank inspections remains in the developmental stage.

The ROV used for the Mobil project did have several interesting features. The ROV was powered by water from the firemain which turned a generator through a water turbine. This system allowed the equipment to be intrinsically safe. Fiber optics were also introduced on deck to complete the intrinsically safe system. The inspection tools on the ROV included a color CCD camera with suitable lighting for close inspection, and an ultrasonic measurement system that employed a pulse echo technique with a single transducer. If necessary, the ROV was also fitted with special purpose cleaning tools, to allow for preparation of steel for taking ultrasonic thickness measurements.

Using an ROV for tank inspections has several additional disadvantages. First is the time consuming procedure involved with conducting an entire tank inspection. Second is the tendency of the inspection team to become disoriented and fatigued while watching the video monitor. The third disadvantage, as with the use of divers, is that the ROVs umbilical cord leading to the topside area may become entangled on the internal structural members such as ladders. A way to reduce this problem would be to develop a miniaturized ROV that could fit through each individual butterworth opening. The inspection would be limited to between frames and the ROV would be less likely to become entangled. Disorientation of the ondeck inspection team would also be reduced.

### 5.3.3 Acoustic Emission

The Acoustic Emission (AE) technique uses the emission of sound from a structural failure when the structure is stressed. Loose structural members or crack propagation will emit high frequency sound when sources undergo a load of sufficient magnitude to cause discrete movements. Piezoelectric sensors are used to detect the sound. The placement of several sensors surrounding a source allows the measurement of the sound's arrival time at each sensor, and thereby allows the calculation of the source location. Many sensors placed in strategic locations may allow global surveillance of a large structure like an oil tanker. Shifting seawater between tanks and the motion of the ship at sea can be used to load the structure in the sensor region.

Use of AE for tank inspection is still in the experimental stage. Exxon Corporation recently conducted a feasibility study aboard the M/T Exxon Benicia in conjunction with Hafa International Inc. The most promising application for AE testing were found to be for tanker deck and possibly bulkhead examination. Currently, AE monitoring of bulkheads is impractical. Permanent installation of immersion type sensors, preamplifiers, and cables would be required. However, AE could be used to inspect the deck area where visual inspection from a raft is difficult. Due to the inordinate number of sensors that would be required to monitor the entire deck area, testing only critical segments of the deck would be appropriate.

One of the difficulties associated with AE testing is background noise. Careful identification of noise sources including date, time and place of occurrence is critical during data acquisition. Background noises such as ballast pumping, butterworth blower vibration, check valves, crane masts and even hose dragging can lead to misleading data. Other factors affect-

ing the feasibility include cost, set up time, and safety considerations including the use of non-intrinsically-safe equipment, and, finally, the degree of coverage capable with this system.

## 5.4 Access-New Technology

This section describes those methods that have not to date been tried for tank inspections, but appear to be promising.

### 5.4.1 Infrared Thermography<sup>1</sup>

An untested method for tank inspections is infrared thermography. Infrared thermography inspection system could be used to detect cracks and corrosion within a steel structure. Infrared thermography has previously been used on concrete structures such as multi-story parking garages and bridge decks. The basic principle behind these inspections is to use infrared thermography to locate temperature differences within the concrete. The detection of a temperature difference may indicate an area where internal corrosion has taken place or voids within the concrete are present.

Infrared thermography has also been used for inspections of coatings on a steel surface. These inspections detect air voids, water blisters, and corrosion between the coating and the steel surface. Infrared radiation is used to heat up a surface and then an infrared scanning sensor measures the temperature. Since the material and coating thickness is uniform, a difference in temperature measurements indicates a possible problem area. This inspection system proves to be rather slow.

There are two basic modes of operation which can be used for inspection purposes. The first requires the object being inspected to be heated up with infrared radiation and then scanned with a two dimensional thermal imaging camera to detect the temperature difference across the objects sur-

---

<sup>1</sup> The material in this section was prepared by Martin Cepkauskas.



face. The temperature differences will be caused by the difference in the heat emissivity properties within and on the surface of the material. The induced heat is used to magnify the temperature differences. The second mode does not require any induced heat. An infrared thermography imaging system is used to detect the surface temperature difference of the object being inspected. These temperature differences are caused by the difference in the heat emissivity properties within and on the surface of the material. The basic principle behind using an infrared imaging system to detect cracks and corrosion is that existence of a defect will change the local thermal conductivity of the material. This temperature difference will be recognizable in an infrared system.

The Plessey Research and Technology Limited, UK and Royal Signals and Radar Establishment have developed a hand held thermal imager. This system is very portable and can be used in field applications. The company is planning to improve the sensitivity of the thermal imaging system and incorporate better quality video output.

The infrared thermography inspection method is particularly appealing in that it is an area inspection technique instead of a point testing technique. This will provide greater coverage than the single point ultrasonic thickness measurement technique. Exxon Corporation conducted a research program in 1980 that determined that generalized thickness measurements could not be relied upon to determine precisely the location or amounts of repairs which might be needed [10]. Detailed visual inspection was necessary to identify areas of high corrosion, using ultrasonic thickness gauging to quantify losses. Infrared thermography, with its area testing capabilities, has the potential to overcome this obstacle.

In order to determine the feasibility using infrared thermography

for tank inspections, a test could be conducted on a known tanker flaw. However, before conducting a test on a tanker, a test could first be conducted in a lab setting that would simulate tanker conditions. Questions that need to be answered in the lab setting include:

1. Is the temperature difference between the crack or corrosion within the tank great enough to be detected by the infrared imaging system currently on the market today?
2. How clean does the tank surface have to be in order to get a functional thermal image of the area being inspected?
3. At what distance should the infrared inspection system be from the area being inspected in order to produce usable data?
4. At what temperature ranges is the infrared inspection system most effective in a tank environment.
5. Do any special measures have to be taken in order to prepare the area to be inspected?

Testing should be carried out using mild and high strength steel plating in various thicknesses typically found in a tanker structure. The following list are suggested test specimens for the infrared testing:

1. A clean control plate which has no cracks, corrosion or coatings. This will be used as a comparison for the other test specimens.
2. One plate with no coatings but with various cracks and corrosion. This will show the sensitivity of the infrared system to imaging different types of cracks and corrosion.
3. One coated plate with no cracks or corrosion. This test will show how coatings affects the infrared images.
4. One plate with oil tank sludge in various spots. This will simulate a typical tank environment.

5. One coated plate with both cracks and corrosion. The cracks should be of various degrees. This will simulate a typical ballast tank environment.

6. One plate with cracks, corrosion and sludge. This will simulate a real, uncleaned cargo tank environment.

7. If time permits, these tests should be conducted at various temperatures that the tank environment may encounter.

The infrared system should be set up in a fixed position with a fixed testing area for the specimens. This will control the test environment which will allow for data comparison on an equal basis. These controls and test specimens should allow for sufficient data for the analysis of the feasibility of using an infrared system for tanker inspections. By analyzing and comparing the data to the control specimen, one should be able to answer the pertinent questions listed above. These tests and analysis should give us a good understanding of the sensitivity and capabilities of using an infrared system for tanker inspections. From this information further recommendations can be made for future research, development, and implementation of infrared technology for tank inspection purposes.

#### **5.4.2 Laser Line Scan System**

Spectrum Engineering Inc. from San Diego initiated a program in 1988 to determine if the laser line scan technique could be used to improve the U.S. Navy's underwater imaging capability. The Laser Line Scan System (LLSS) was first tested in a laboratory setting. The system as tested used a 40 milliwatt Argon ion laser as the light source and a 2-inch diameter photo multiplier tube (PMT) as the detector. The LLSS was then

then installed aboard the Navy's research submarine USS Dolphin to evaluate the operational potential of this new underwater imaging technique by creating images of submerged objects off the coast of San Diego. The results showed that the LLSS is capable of producing better images than a conventional low light television camera that had already been installed aboard the submarine. Spectrum Engineering anticipates extension of field testing to cover a wider range of environmental conditions, from very turbid to clear water, and a wider range of platforms, including ROV's. Additional research is also aimed at improving the video image quality. This system also merits further lab testing similar to the specifications as outlined in section 5.4.1.

## 5.5 Access Summary

All methods discussed in Chapter 5 have advantages and disadvantages. Improved tanker design method (5.1) has the potential to be the best method for improved access. However, the improvement to access must be weighed against the additional costs, ship weight, maintenance and unwanted structural detail associated with this method.

Methods that require suspended cables or ropes (5.2.3, 5.2.4, 5.2.8) have difficulties associated with the initial rigging. Methods involving a video camera (5.3.1, 5.3.2) being used in a ballasted tank have difficulties due to the turbidity of the water, and the lack of the cleanliness in the tanks. Those methods that do not allow the inspector to have hands on access to the structural members do not allow removal of rust or oil residue buildup. Those methods involving new technology for improved access (5.4) will require further testing before implementation. A complete summary of all the methods including the advantages and disadvantages are included in table 5-1.

<b>Method</b>	<b>Advantages</b>	<b>Disadvantages</b>
Tanker Design	Safety, increased accessibility	Cost, weight, maintenance, unwanted structural detail
Walking the Bottom	Inexpensive	Poor accessibility, only line of sight view
Climbing w/o Fall Safety Device	Increased accessibility	Unsafe
Physical Climbing w/ Fall Safety Device	Increased accessibility, inexpensive	Initial rigging difficult, physically demanding
Access to Side Member w/ Ascender	Increased accessibility, inexpensive	Initial rigging difficult, training required
Fixed Staging	Access available to all members in party	Expensive, labor intensive
Rafting	Can be accomplished underway, inexpensive	Considered unsafe by some, expensive, time consuming
Binocular with High Intensity Light	Can be accomplished underway	Hands on inspection not possible, only line of sight view
Portable Staging	Light repairs possible, relatively safe	Expensive, difficult initial rigging
Mechanical Arm	Increased accessibility	Difficult initial rigging
Divers	Can be accomplished underway	Diver inexperienced in ship inspections, time consuming
ROV	Can be done underway, gas freeing tank not required if equipment is intrinsically safe	Expensive, easy for operator to become disoriented
Acoustic Emission	Can be accomplished while vessel is in service provided equipment is intrinsically safe	Only tank top area currently feasible
Infrared Thermography	Area inspection technique	Untested method for tank inspections, experimental
LLSS	Improved video imaging	Untested method for tank inspections, experimental

### Access Methods Summary

**Table 5-1**

## 6. Recording the Survey

When conducting an internal structural survey, typically the inspector will carry a small pocket size notepad and pen. The defects will be recorded in the notepad and will be reviewed once outside the tank.

Some inspectors carry a 35 mm camera so that a photo can be used to accompany the narrative. However, when the 35 mm camera is not intrinsically safe and therefore, the tanks should be gas free and safe for hot work. The inspector records the location, the structural member affected, the size of the defect, and a recommended repair. The inspector will usually have on leather gloves and will often have to remove one of the gloves so that the information can be recorded. The tank's grime often finds its way onto the inspector's notepad. This can make notes difficult to decipher once outside the tank. Rafting poses additional problems; the inspector and all his equipment may become wet. Upon completion of the survey, the inspector has to transcribe the information to a smooth form for others to take appropriate action. The final survey report is presented in various forms ranging from handwritten list, typewritten list, straight narrative, graphical representations, or graphical representation with 35mm photograph. A sample of these forms can be found in Appendix C.

Several alternatives to recording the survey in a notepad have been used. Small tape recorders can be used, but the difficulty lies in transcribing the information. Once the inspector is out of the tank, he still must review the tape and record the information in written form. Another option is to have an additional person in the inspection party to act as the recorder. This is particularly helpful to the inspector, who can then concentrate on locating defects rather than fumbling with a pen and pad every time infor-

mation must be recorded. For this strategy to be effective, the recorder must be familiar with tank nomenclature. Voice communications can be difficult while in the tank. With the new benzene standards, most tanks carrying crude oil or other products containing benzene are often not clean enough to enter without some sort of respiratory protection. The marine chemist will usually require a filter half mask with organic vapor cartridges. This half mask makes communication between inspectors in the tank extremely difficult, so that an additional person acting as a recorder may not be a viable alternative.

A more automated process for recording the information obtained during the survey could improve efficiency. In addition, the need to transcribe the information when outside the tank would be eliminated if the original record was computer readable. Data recorded in the tank could then be downloaded onto a computer. Either of two devices could be used to accomplish this task.

The first would be a microprocessor-based data collection device similar in size to a hand-held calculator or computer. The device would prompt the user as to location, type of defect, and recommended repair. Hand held computers have seen widespread application in other segments of industry. This type of device is now being used in restaurants where waiters take customers' orders. The information the waiter inputs include table number and food items from the menu. This same device could be applied for recording structural defects within the tank.

The other device that would be a portable voice data collection device. These speech recognition devices are capable of interpreting the human voice and converting it to machine language. An example is the Talkman, manufactured by Vocollect Inc. (Figure 6-1). The Talkman is



belt mounted and includes an attached headset with microphone. The Talkman case weighs less than 2 lbs. and dimensions are 4.25" X 7.5" X 1". This system is completely portable and would be particularly appealing to the inspector because his hands would be free for other tasks such as climb-



Vocollect Talkman

**Figure 6-1**

ing and chipping. The inspector enters data by verbally responding to a series of questions. Once data is collected from either system, it would be downloaded to the office computer.

The inspector's job is to communicate to those outside the tank the condition of the structural members inside the tank. With an automated system, consistent nomenclature is particularly important. Unfortunately, nomenclature is not standard throughout shipping industry. The key to devising any automated data collection system is to use a standard set of nomenclature to be used by all individuals involved with ship surveying and repairs. Appendix D is a sample standard nomenclature system used by Chevron Corp. that could be used for a typical longitudinally framed ship. However, the input prompts used in the automated system should be tailored to each individual ship.

A procedure for recording defects has to be devised for use with an automated data collection system. Appendix E contains a sample coding scheme for recording defects of structural members within a tank. The coding system is adapted to Chevron Shipping Company's standard structural nomenclature (Appendix D). However, coding systems can be devised similar to Appendix E for nomenclature used in other ships. The first seven prompts locate and name the structural member. When entering the information into the hand held system or Talkman system, the inspector needs no prior information as to the numbering scheme for the tank. The ship inspector would need minimal training to learn the generic numbering scheme for data entry. The computer would then translate from the generic system to that used in the ship's plans. For example, if the inspector wished to enter a defect for bottom longitudinal #18 he could enter this as the third longitudinal from the starboard bulkhead. When the information

is downloaded into the office computer, a program would be able to convert this information to the correct numbering sequence as shown by the ship plans. Once the location and the name of the structural member has been entered, the inspector will then be able to enter the defect type, dimensions of the defect, and repair recommendations. The hand held unit or Talkman would prompt the inspector with the next item to input. For the hand held unit, the input items would be from a menu. The inspector would select the appropriate menu. For example, if the prompt was "Structural Member?", the unit would display all those members applicable to the location of the tank previously input. The inspector would scroll to the appropriate member and hit the enter key. All screen prompts would be handled in a similar fashion.

A typical example might be as follows. If an inspector wished to record a 20 cm crack in the #2 center cargo tank located at the vertical bracket #8 starboard on bottom transverse frame #81 (using Appendix D as a guide), the inspector would enter it as shown in Table 6-1. This information would be downloaded into the office computer as follows; 2C, Bottom, 81 81, Upper, 8, Bracket, Crack, 20, Vee and Weld. This data then could be remanipulated and output in tabular form listing location, defect type, size, and repair recommendation.

Upon completion of the inspection survey, the database of the survey would be ideally suited for input into a data/graphics program such as CATSIR (Computer Aided Tanker Structures Inspection and Repair) developed by Chevron Shipping Company. As discussed in the introduction, CATSIR is a program for recording inspection and repair specifications which allows the information to be displayed in either graphical or report format.

<u>Screen No.</u>	<u>Screen Prompt</u>	<u>Input</u>	(Comments)
1.	Tank No. ?	2C	
2.	Location in Tank ?	Bottom	
3.	Frame # ?	81, 81	Entered twice to indicate defect at frame and not between.
4.	Height ?	Upper	(Location of member on frame.)
5.	Longitudinal # ?	8	
6.	From Port, Stbd, or C/L?	C/L	
7.	Structural Member ?	Bracket	
8.	Defect Type ?	Crack	
9.	Size?	20	
10.	Repair Recommendation ?	Vee and Weld	

Sample Defect Data Entry  
**Table 6-1**

Both the Talkman and hand held data collecting device are available on the market. If these types of systems are to be feasible for survey use, the equipment must be able to withstand the rugged environment that the inspector would subject the equipment. Most equipment brought into a tank with the inspector will become covered with mud and oil. The Vocollect case worn around the waist would need to be housed in some type of protective softbound case. The hand held device would likewise have to be housed in a protective softbound case with a clear plastic area for the keypads and screen. The clear plastic area could be wiped clean with a sol-

245 22

vent at the conclusion of the tank inspection. Ideally the individual key-pads should be large enough so that the inspector does not have to remove his gloves during data entry.

## **7. Quantitative Analysis of Alternative Access Methods**

The various methods used to gain access to the internal structural members have been discussed in this report. If you were to ask those in the inspection business which method is superior, you would obtain a wide variety of answers. If you further asked those same individuals which method would detect more defects and which was the most efficient in terms of time spent, you would likewise obtain a wide variety of answers. These answers are informed opinions based on experience.

All parties involved in the inspection process would like to use a method to gain access that would allow the detection of defects as efficiently as possible. Over the history of ship inspections, each inspector or organization has adapted methods they feel are the best based on experience. When a new method becomes available, such as the portable scaffolding, it takes time to gain the experience necessary to determine which method is preferred. A rational means of quantitatively comparing methods could speed this process. This chapter presents the design of an experiment that could be used to quantitatively compare various tank inspection methods. An experiment could be conducted in order to determine statistically if one method is clearly superior in terms of time and number of defects detected. The latin square design can be used to test the difference between alternative access methods (Figure 7-1). The latin square design is described in experimental design textbooks [28], [29]. A brief synopsis of the experimental design process including the latin square is included in Appendix F.

### **7.1 Variables in Tank Inspection**

Inspectors, tanks, and methods are all variables in the experimental

process. As any inspector knows, it takes a lifetime to become a fully qualified steel inspector and experience is often the best teacher. Each inspector has different insight into where cracks and other defects might be located and thus the inspector becomes a variable that needs to be isolated in the experimental design.

Another variable in the experiment is tanks. There is wide range in the number of defects found depending on which tank is entered. A ballast tank is different from a cargo tank. A vessel might experience more cracking in the port tanks than in the starboard tanks. In addition, the manner in which a ballast tank is inspected is different from the way in which a cargo tank is inspected. For example, cracks are often detected by locating rust bleeds in a ballast tank. The tank thus becomes a variable that needs to be isolated.

Inspection method is the variable we wish to study in this experiment. Although any one of the methods used to gain access discussed in Chapter 5 could be employed in this experiment, it makes sense to start with those methods that are most common. Those methods recommended for the initial experiment include:

- (1) Bottom walking the tank only
- (2) Bottom walking the tank with binoculars
- (3) Rafting
- (4) Portable Scaffolding (Spider)

Although bottom walking the tank is widely believed to be an inferior method, it is important to determine this quantitatively, including the number of defects being overlooked by this method. Innovative methods to be developed and desiring testing could be compared in the future from the method that is found to be superior from the initial experiment.

## 7.2 Description of Proposed Experiment

When variables need to be isolated, a latin square design, as shown in Figure 7-1 can be used. In the experiment described here, the latin square is used to isolate the effect of inspectors and tanks from the effects of inspection methods. It is important to minimize the impact of these variables in the experimental design.

The proposed experiment would use four tanks, four methods and four inspectors. In the first tank, each inspector would use one of the four methods to gain access to the structural members. Each inspector would conduct his survey separately from the other inspectors. It is important to not allow the inspectors to confer with one another so as to not bias the experiment. Each inspector would record the location, the type and the size of defect found. The steel should not be marked as this would show the following inspector the location of defects found from the previous inspector. After the first tank is completed, the inspectors and equipment would move to the second tank and the process repeated. Each inspector would be given a different method to gain access than was used in the first tank. This process would be repeated for all four tanks. To the extent possible, the inspections would be conducted in parallel in order to reduce the overall time to conduct the experiment.

It is recommended to use four inspectors with approximately the same level of experience so that wide fluctuations in this variable is not introduced into the experimental process. It is also recommended to use four tanks that are believed to have a similar number and types of defects. For example, use four cargo tanks on the port side. Another separate experiment could be conducted using four ballast tanks. In this second experiment, the preferred method could be entirely different from the preferred



I  
N  
S  
P  
E  
C  
T  
O  
R

Tank No.

	1	2	3	4
1	A	B	C	D
2	B	C	D	A
3	C	D	A	B
4	D	A	B	C

- METHODS:** A. Bottom Walking Only  
B. Bottom Walking With Rafting  
C. Bottom Walking with Binoculars  
D. Temporary Scaffolding (Spider)

- DATA:** A. Number of Defects Detected  
B. Time Required to Complete Tank Inspection

Quantitative Assessment  
(Latin Square)

Figure 7-1

250

method determined in the first experiment. Initially, it is recommended to concentrate on one particular type of cargo tank conducting only one experiment due to the time and resources that would be required for the experiment.

The most opportune time to conduct this experiment is before the ship goes into the shipyard for repairs. Many ships conduct a preliminary rafting survey prior to entering the yard. This would be an ideal time in which the experiment would produce minimal interference with the ships planned activities.

The 4 X 4 latin square is the optimum size for the tank inspection experiment. The size of the latin square determines the number of degrees of freedom available for estimating the variance ( $\sigma^2$ ). Degrees of freedom can be thought of as bits of information available for estimating the unknown parameters associated with the linear model. This linear model is shown in Table 7-1 and further discussed in section 7.3.  $\sigma^2$  is the variance of the random error  $\epsilon$ . The number of degrees of freedom available for estimating  $\sigma^2$  is equal to the number of observations in the experiment less one degree of freedom for each parameter in the linear model. For the 3 X 3 latin square, the number of degrees of freedom associated with the estimate of  $\sigma^2$  is two, a very small number. The effect of a loss in degrees of freedom is much less for a 4 X 4 latin square or larger. The 4 X 4 latin square would leave 6 degrees of freedom for estimating  $\sigma^2$ . A 5 X 5 latin square would provide additional degrees of freedom for estimating  $\sigma^2$ . However, for the tank experiment, the 5 X 5 latin square would be much more difficult logistically. Therefore, the 4 X 4 latin square is preferred for the tank inspection experiment.

### 7.3 Analysis of Results

The latin square model allows a linear model to be constructed to rep-

For the 4X4 Latin Square as shown in figure 7-1  
the linear model would be as follows:

$$y = \beta_0 + \beta_1x_1 + \beta_2x_2 + \beta_3x_3 + \beta_4x_4 + \beta_5x_5 + \beta_6x_6 + \beta_7x_7 + \beta_8x_8 + \beta_9x_9 + \epsilon$$

- $\beta_0$  - response for treatment A in row 1 column 1
- $\beta_1$  - difference in the response between rows 2 and 1
- $\beta_2$  - difference in the response between rows 3 and 1
- $\beta_3$  - difference in the response between rows 4 and 1
- $\beta_4$  - difference in the response between columns 2 and 1
- $\beta_5$  - difference in the response between columns 3 and 1
- $\beta_6$  - difference in the response between columns 4 and 1
- $\beta_7$  - difference in the response between method 2 and 1
- $\beta_8$  - difference in the response between method 3 and 1
- $\beta_9$  - difference in the response between method 4 and 1

Linear Model For the 4X4 Latin Square

**Table 7-1**

resent the above tank inspection experiment (Table 7-1). From the linear model an ANOVA (analysis of variance) table can be constructed as shown in Appendix F. The final column in the ANOVA table is the computed F statistic. This value is compared to a tabulated F value found in any experimental design textbook. The F tabulated value is based on a specified confidence level. For the 4 X 4 Latin square, F tabulated with a 95% confidence interval gives a value of 4.76. If the F computed from the ANOVA table is greater than the F tabulated, then you can be certain with a 95 % confidence level that a difference exists between either the rows, treatment or columns. In

the tank experiment, rows are the inspectors, columns are the tanks, and treatments are the methods used to inspect the tank. The difference between inspectors and tanks could be determined and might be relevant for training, setting standards, etc.. However, of primary interest in this experiment is to determine if there is a difference between the methods used in terms of time and number of defects detected.

The failure of the F statistic to indicate a difference between treatments could be caused by insufficient replication of the experiment or by the fact that the differences are truly negligible. Should the experiment fail to show a difference, it probably would not be cost effective to replicate the experiment.

The F statistical test is a general test to determine if a difference exists among all the methods. It will not determine if there is a difference between individual methods. Assuming that the F statistic does in fact show that a difference in methods does exist, further statistical analysis needs to be conducted between individual methods. There are two types of statistical analysis that can be conducted to determine the difference between the individual methods: the null hypothesis and determining a confidence interval.

For testing a hypothesis for the linear model shown in Table 7-1, a hypothesis may be generated for the parameters of B7 (difference between methods 2 and 1), B8 (difference between methods 3 and 1) and B9 (difference between methods 4 and 1). In addition to these, hypothesis may be generated for B9-B8 (difference between method 4 and 3), B9-B7 (difference between method 4 and 2), and B8-B7 (difference between methods 3 and 2). The hypothesis to be tested would be:

Null Hypothesis                       $H_0 : B_i = 0$  (no difference exists)

Alternative Hypothesis                 $H_a : B_i \neq 0$  (a difference exists)

Assuming a normal population of defects,  $t$  can be calculated where:

$$t = \frac{\hat{\beta}_i - \beta_i}{s\sqrt{c_{ii}}}$$

The values used to compute  $t$  can be determined from the experimental data. Information concerning computation of the  $t$  statistic can be found in Appendix F. This value is compared with  $t$  tabulated in any experimental textbook. For the 4 X4 Latin square, a 95% confidence interval would give a  $t$ -tabulated value of 2.571. If  $t$ -calculated exceeds  $t$ -tabulated, then the null hypothesis can be rejected and the alternative hypothesis can be accepted. If  $t$ -calculated does not exceed  $t$ -tabulated then the null hypothesis cannot be rejected. In this case additional experiments may need to be collected or a difference truly does not exist. For the tank experiment proposed, additional tests may be cost prohibitive.

The other statistical analysis that may be conducted is determining a confidence interval. A confidence interval may be determined for the  $\beta_i$ 's where the confidence interval is  $\hat{\beta}_i \pm t_{\alpha/2} s\sqrt{c_{ii}}$ . The student  $t$  table is used to determine  $t_{\alpha/2}$ . For example, a 95% confidence interval would yield a value of  $t_{\alpha/2} = 2.571$ . Additionally, a confidence interval may also be determined for each method. Each method would for example have an average number of defects detected plus or minus a confidence interval (95%), where the confidence interval can be calculated for each average response is  $\bar{y} \pm t_{\alpha/2} \frac{s}{\sqrt{n}}$ .

The two tests described above, testing the null hypothesis and determining a confidence interval, should provide information to determine which method is superior in terms of number of defects detected and time required to complete the tank inspection. With this base information, new methods and technologies can be compared in a similar experiment to the one outlined above. The new methods would be compared against the method found to be

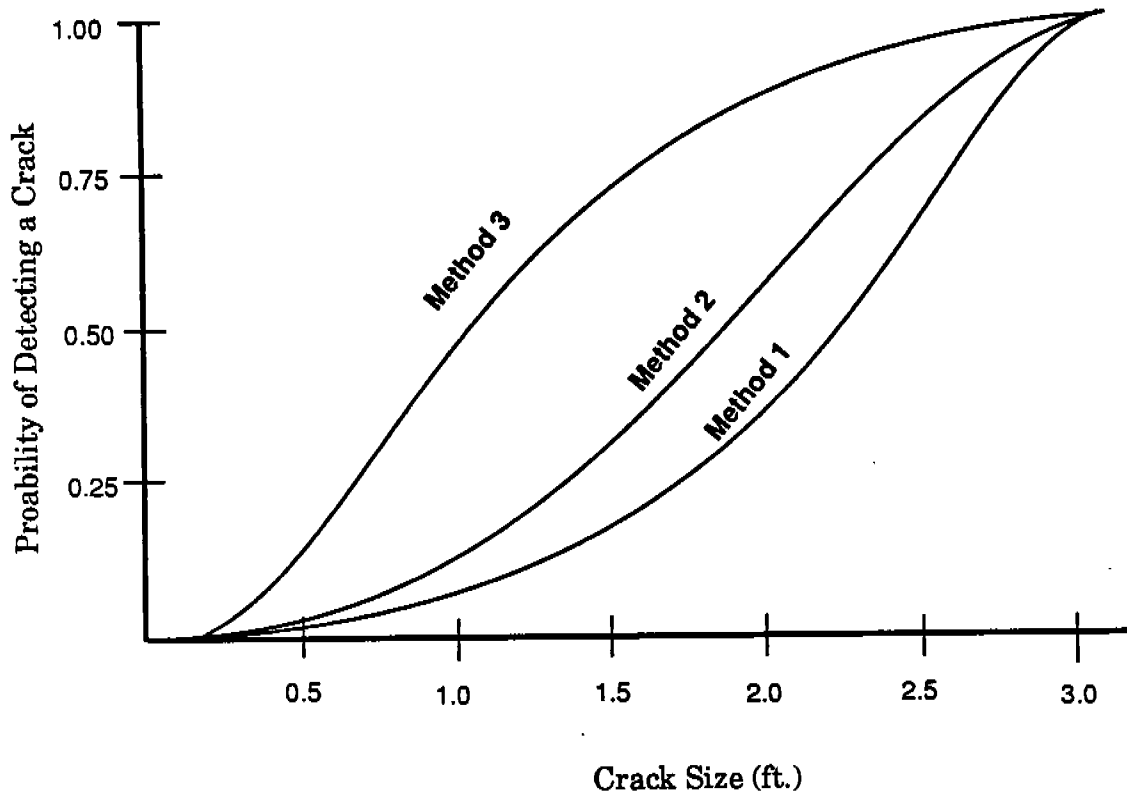
superior from the first experiment. Without the latin square experiment, methods will continue to be compared based on informed opinions.

#### **7.4 Probability of Detection**

In addition to comparing methods, the data obtained in the experiment could be used to generate probability of detection curves. Probability of detection is the probability that a defect will be found during an inspection. This has always been a difficult concept in the tank inspection business. Although defects are found during a tank inspection, one can not be sure how many defects have not been found during the inspection. Typical probability of detection curves might look like figure 7-2.

Curve 1 might represent a curve obtained from bottom walking the tank only. Curve 3 might represent a curve obtained when the tank is inspected by rafting. One would expect a higher probability of detection from the rafting method than that of the bottom walking method due to the increased coverage obtained by the rafting method. The difference between the rafting method and the portable scaffolding method is not so obvious. For example it may be easier to detect a crack when the tank walls are dry with the portable scaffolding method than when the tank walls are wet with the rafting method.

The tank inspection experiment may provide some insight into the probability of detecting a defect. In the proposed experiment, one method will detect a certain number of defects, say cracks. Another method will detect another set of cracks, some of which may not be in the set of the first method. A comparison of the results of all methods will determine the total number of defects found. It is assumed that the total set of defects found in the experiment is the total number of defects in the tank. The results of each individual method will be compared with the total set of defects found.



Schematic Probability of Detection Curves  
for 3 Inspection Methods

**Figure 7-2**

The number of defects found can be broken down into crack sizes. From this breakdown, probability of detection curves can be constructed similar to those shown in figure 7-2.

These curves will give inspectors the first glimpse towards understanding the number of defects that do in fact go undetected. Further analy-

sis can be conducted to determine particular regions in a tank that are more susceptible to cracks being overlooked. Additionally, these probability of detection curves will further help to demonstrate which method is superior.

Probability of detection curves are particularly important for the naval architect. With these curves, a probabilistic approach can be taken towards design. For example, fatigue curves of steel plot number of cycles vs. crack size. By knowing the probability that a given size crack may be detected, the naval architect is able to design a structure that will withstand a particular size crack that may go undetected.

Before conducting the experiment described here, the costs and the time involved should be considered. Although the vessel will already be out of service for the tank inspection, the experiment will incur additional but limited out of service time. With all the manpower and equipment assembled, the experiment could be conducted in two to three days. The majority of the time would be consumed by ballasting the tanks for rafting. Very little out of service time would be consumed by conducting the inspection by the other three methods, when done simultaneously with the rafting method. Costs can be considerable for any tank inspection. However, when conducting the four simultaneous inspections, there are added costs due to the additional manpower and equipment. The experiment will require three additional inspectors and the necessary support crew needed for the individual methods such as the portable scaffolding method. Additional equipment will also be required for the experiment such as binoculars, high intensity light, and the equipment needed for the portable scaffolding method.



## 8. Summary and Conclusions

Tanker inspections could be improved in many ways: improving the inspector's tools, improving access to the internal structural members, and improving the way in which the results of an inspection is recorded. The improvement development process will continually require the input from the experienced inspector. Further brainstorming sessions such as that held in Portland, Oregon should be continued.

The inspector has to carry many tools that aid the inspection process. Improvements in essential tools, such as the flashlight, should receive top priority. The inspector chooses a flashlight that is bright, lightweight, and compact. However, this is a hard combination to find. A tradeoff is usually necessary. The MSA Caplamp Lighting System provides hands free operation, but is not the overall solution. Its battery is heavy and cumbersome, and the inspector is forced to rotate his head to direct the light. With the necessary modifications, this system would be ideal.

Improved access can be accomplished in four ways: improved tanker design, improved access for the inspector in the tank, improved access with the inspector out of the tank, and finally by researching new technology that will improve the inspection process.

In the near future, improved access with the inspector in the tank is the most promising solution. Rafting with climbing has generally been considered to be the preferred method. However, with the recent

introduction of portable staging, the preferred method is not so clear. In fact, all the methods discussed have their advantages. In order to have more definitive information as to which method is superior, a quantitative assessment as outlined in Chapter 7 should be conducted. This will provide the statistical evidence to decide which method is superior in terms of the number of defects detected and the time required to conduct the inspection. The ship owner must then weigh this information against the costs associated with each method, and then decide which method should be implemented. The quantitative assessment will also provide data to generate probability of detection curves. For example, these curves plot the probability that a crack will be detected versus the size of the crack. This will give the naval architect information to pursue a more probabilistic approach towards tanker design.

Improved access with the inspector out of the tank has its advantages. The main advantage is that it removes the inspector from a potentially dangerous environment. Unfortunately, limited success has been obtained from the methods discussed in this report.

Improved access through new technology, namely infrared thermography and the Laser Light Scan System has potential application for the inspection process. Before these methods see application in tank inspections, further testing needs to be conducted to determine their feasibility. A plan for this testing has been outlined in section 5.4.

Improved tanker design is the best method to improve inspector

access. Unfortunately, improved access through design is costly, and adds weight and additional maintenance requirements. Once again, the ship owner must decide whether improved access warrants these expenses. In the past, many ship owners have said that they do not. Today, with increased concern over the environment and vessel safety, improved inspections have become an important issue. Many ship owners are beginning to reassess their positions.

Improvements to the inspection process can also be accomplished by automating the method in which the survey is recorded. With an automated method such as those outlined in Chapter 6, the inspector could easily download survey data to the office computer for further analysis. With the requirement of all TAPS vessel to have CAIP onboard, this concept is particularly appealing. Although TAPS vessels have received the most recent attention, the need to determine defect trends on all tankers is important. Testing an automated method as outlined in Chapter 6 in an actual tanker environment needs to be pursued.

This report has laid the groundwork for improved tanker inspection. The report compiled a comprehensive review of the available technology available for tank inspections. It has also outlined several plans for continued work in this field including a proposed experiment for comparing inspection methods and a coding procedure for automated data collection.

As stated in *Tanker Spills: Prevention By Design*, "The term risk

can be defined as the possibility of suffering harm from a hazard. A hazard is a source of risk and refers to a substance (such as crude oil), an event (e.g., an oil spill) that harms the environment, or a natural hazard (e.g., a hurricane). One way to define risk is to ask the following fundamental question: What can go wrong?, What is the likelihood of that happening?, If it does happen, what are the consequences?" [32]. We pretty well know what can go wrong and we have seen the consequences. Emphasis needs to be placed on reducing the likelihood of such circumstances occurring. With improved tanker inspections, this likelihood will be reduced.

## References

- [1] Tanker Structural Co-operative Forum, "Guidance Manual for the Inspection and Condition Assessment of Tanker Structures", issued by International Chamber of Shipping Oil Companies International Marine Forum, Witherby & Co. Ltd., London, 1986.
- [2] Sipes, J.D., MacDonald, J.M., Bowen, M.R., Cojeen, H.P., Salerno, B.M., Maxham, J.C., Baxter, J., "Report on the Trans-Alaska Pipeline Service Tanker Structural Failure Study", U.S.Coast Guard, June 1990.
- [3] Bell, H.H., Carteret, J.E., Janecek, R.A., Deleonardis, J.P., Salerno, B.M., "Report of the Tanker Safety Study Group", U.S. Coast Guard, October 1989.
- [4] Bea, R.G., Polaard, R., Schulte-Strathaus, R., Baker, R., "Structural Maintenance for New and Existing Ships: Overview, Fatigue Cracking and Repair", Proceedings, Marine Structural Inspection, Maintenance, and Monitoring Symposium, March 1991.
- [5] 11th International Ship & Offshore Structures Congress, "Inspections, Monitoring, Maintenance / Repairs", Report of Committee V.2, 1991.
- [6] Weber, P.F., "Structural Surveys of Oil Tankers" Exxon Paper Presented at Joint Meeting Institute of Marine Engineers and Royal Institution of Naval Architects, Transactions, Institute of Marine Engineers, Vol. 96, 1984.
- [7] Tikka, K., Donnelly, J.W., "Computer Aided Tanker Structures Inspection and Repairs (CATSIR)", Proceedings, Marine Structural Inspection, Maintenance, and Monitoring Symposium, March 1991.
- [8] Exxon Corporation Position Paper, "Large Oil Tanker Structural Survey Experience", June 1982.

- [9] The Tanker Structure Co-operative Forum Joint Meeting with Shipbuilders, "Inspection Procedures and Their Influence on Tanker Design", Presentation Paper, November 1987.
- [10] Exxon Corporation, "Proposed White Paper on Structural Surveys of Oil Tankers", April 1982.
- [11] Basar, N.S., Jovino, V.W., "Guide for Ship Structural Inspections", Final Technical Report on Project SR-1289 under U.S. Coast Guard Contract No. DTCG-23-C-20036, 1985.
- [12] Strait, G.J., "Inspection Methods and Equipment", Proceedings, Marine Structural Inspection, Maintenance, and Monitoring Symposium, March 1991.
- [13] Ternus, R.A., "Inspection and Structural Maintenance of Chevron's Tanker Fleet", Proceedings, Marine Structural Inspection, Maintenance, and Monitoring Symposium, March 1991.
- [14] Ferguson, J.M. "Some Considerations Regarding Tank Inspection Priorities for Oil Tankers", Proceedings, Marine Structural Inspection, Maintenance, and Monitoring Symposium, March 1991.
- [15] Dover, W.D., Dharmavasan, S., Topp, D.A., Lugg, M.C., "Fitness For Purpose' Using ACFM for Crack Detection and Sizing and FACTS / FADS for Analysis", Proceedings, Marine Structural Inspection, Maintenance, and Monitoring Symposium, March 1991.
- [16] Buffkin, M.D., Inspection and Monitoring of Marine Structures, U.C. Berkeley Masters of Engineering Thesis, December 1990.

[17] Giannotti & Associates, Inc., "A Non-Experts Guide for Inspecting and Determining the Cause of Significant Ship Fractures", Ship Fracture Mechanism Investigation SR1290, Project No. 8317.01 for U.S. Coast Guard Contract No. Dtcg 23-85-C-20040, March 1987.

[18] Seng-Kiong, T., Sunder, S.S. "Testing and Monitoring of Offshore Structures: A State of the Art Review", July 1982.

[19] Mansi, M.V., Porter, S.G., Braddick, R.C., "A Hand Held Thermal Imaging Employing a Staring Array of Pyroelectric Detectors", Fourth International Conference on Advanced Infrared Detectors and Systems, June 1990.

[20] Elliot, T., "Infrared Measurement of Surface Temperature Now a 'Hot' Option", Power, March 1990.

[21] McKnight, M.E., Martin, J.W., "Detection and Quantitative Characterization of Blistering and Corrosion of Coatings on Steel Using Infrared Thermography", Journal of Coatings Technology, Vol. 61, No. 775, August 1989.

[22] Hartikainen, J., "Inspection of Plasma-Sprayed Coatings Using Fast Infrared Scanning Technique" Review of Scientific Instruments, Vol. 60(7), July 1989.

[23] Harris-Stewart, C., "Scanning for Corrosion", Engineering News Record, June 1988.

[24] Basar, N.S., Jovina, V.W., "Planning and Conducting Improved Ship Structural Inspections", Presentation Paper No. 12, Spring Meeting / Star Symposium, Portland Oregon May 20-23, 1986.

[25] "Acoustic Emission Feasibility Study Synopsis - Exxon Benicia", Report No. 1038-90S, Hafa International Inc., January 1991.

[26] Trans-Alaska Pipeline Service (TAPS) Tanker Structural Failure Study Follow up Report, Prepared by the United States Coast Guard Office of Marine Safety, Security and Environmental Protection, May 1991.

[27] Pattofatto, G., "The Evolution of Inspection and Repair Procedures for Ship Structures", Proceedings, Marine Structural Inspection, Maintenance, and Monitoring Symposium, March 1991.

[28] Diamond, William. J., Practical Experimental Design for Scientist and Engineers, Wadsworth Publishing Co. Inc., 1981.

[29] Mendenhall, William, Introduction to Linear Models and the Design and Analysis of Experiments, Wadsworth Publishing Co. Inc., 1986.

[30] "Laser Line Scan System (LLSS) Field Evaluation (February 1990 thru February 1991)", Project 4312 Technical Report, prepared by Spectrum Engineering, Inc. May 1991.

[31] Exxon Corporation Circular Letter C-12-04, Supplemental Enclosed Space Entry Procedures: Rafting, July 22, 1991.

[32] "Tanker Spills: Prevention By Design", Committee on Tank Vessel Design, Marine Board Commission on Engineering and Technical Systems, National Research Council, National Academy Press, February 12, 1991.



## Appendix A

### Portland Brainstorm 30 May 1990

#### I. What are your least favorite aspects of tank inspections?

What are some difficulties encountered?

What is unsafe about your job?

*Responses fell under 2 categories:*

#### A - Personal safety hazards and difficulties

1. Lack of cleanliness (mud, excess oil, residue)

A. Safety concerns

2. Physical Hazards (ie. falling)

Job is hazardous, even bottom walking.

You don't have to fall from a significant height to get injured.

2. Toxic Hazards (ie. hazardous vapors)

3. Insecure feelings

4. Fatigue

5. Lack of ventilation (safety, comfort)

6. Weather conditions (heat, ice), (safety, comfort)

7. Blasting dust

8. Too much gear to carry

9. Difficult communication with other inspectors  
and on deck

#### B - Structural design problems

1. Lack of reference points

2. Lack of accessibility

3. Lack of vertical ladders (ie. to get over web frames)
4. Poor lighting
5. Lightening holes too small for human passage
6. Lack of double bottom clearance
7. Rotted framework, ladders

(suggestion: make ladders out of fiberglass)

## **II. What equipment do you use?**

1. 2 flashlights (one for emergency escape)
2. Hammer
3. Wire brush
4. Safety glasses
5. Steel tip boots
6. Leather gloves
7. Putty knife
8. Pen and pad
9. Hardhat
10. Hearing protection
11. Filter respirator (half mask)
12. Chalk or spray paint
13. Coveralls (disposable)
14. Oxygen analyzer
15. Emergency Escape Breathing Apparatus (EEBA)
16. Surveyors may use cameras (Will record picture # with location of defect)

### **III. How do you find, locate and record structural defects?**

1. Location of defect (need to know scheme before entering tank)  
Frame #, Sidelong #, etc.
2. Defect type (size and type)
3. Sketches
4. Use of a third person as a recorder
5. Some defects are not found until after the ship is in the yards and the work has begun

### **IV. What are some techniques used to gain access?**

1. Rafting
2. Free Climbing
3. Climbing with ropes (some found it to be difficult and not worth the trouble)
4. Installed catwalks
5. Divers
6. Binoculars and bright light
7. Ziggy (Hydraulic Arm and Basket through butterworth operated from deck)

### **V. What are your suggestions?**

1. Miners lamp, good when there is climbing involved
2. Bazooka light (120v, not intrinsically safe)
3. Horizontal girders in wing tanks
4. Design tankers for improved accessibility
5. Recording of defects by a 3rd person

6. Additional catwalks would be helpful
7. Tape recorders (need to be capable of withstanding tank environment)
8. Voice Activated Tape Recorder
9. Spider (hydraulically operated window washer type device)  
Each person should have a safety line
10. Would prefer tank clean, well lit, and well vented

Appendix B  
Hazardous Locations Description

RECOMMENDED PLAN REVIEW CHECK-OFF FOR HAZARDOUS LOCATIONS

1. Has sufficient information been provided?

- (a) Hazardous cargoes;
- (b) An arrangement plan identifying hazardous and non-hazardous areas, cargo system or hazards, electrical equipment type and locations;
- (c) A complete and detailed Bill of Materials;
- (d) Elementary and one-line wiring diagrams, showing all wiring;
- (e) Electrical installation details;
- (f) Nationally Recognized Testing Laboratory (NRTL) label or listing for explosionproof (EP) and intrinsically safe (IS) equipment and systems; and
- (g) Maximum temperature ratings of electrical equipment in hazardous areas.

2. Identify hazardous characteristics:

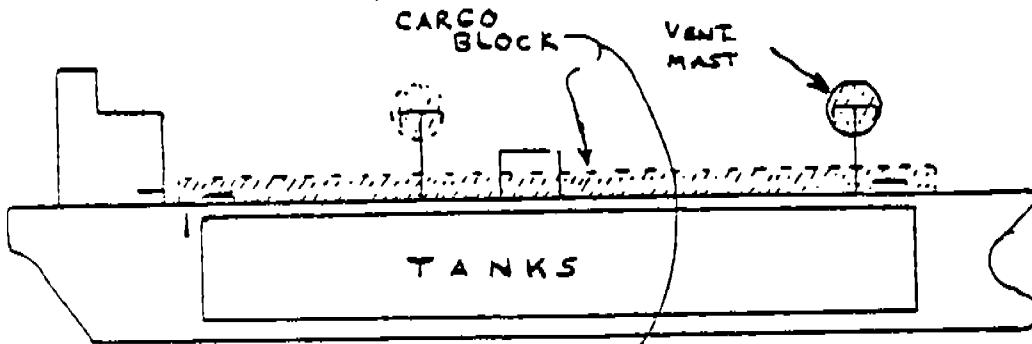
- (a) Class and group;
- (b) Flashpoint and grade;
- (c) Minimum ignition temperatures; and
- (d) Special requirements, including material compatibility.

3. Confirm boundaries of hazardous locations and suitability of equipment installed.

4. Confirm that the installation meets:

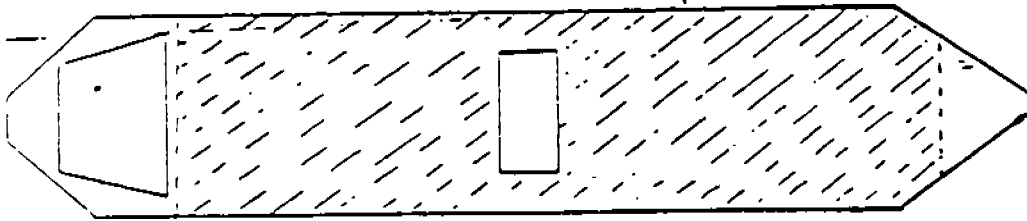
- (a) Subchapter J;
- (b) Intended application by a NRTL (currently UL, FM, CSA, and MET are acceptable to the Coast Guard);
- (c) Specific requirements for the cargo/material; and
- (d) General considerations of this NVIC.

TANKSHIP WEATHERDECK CRITERIA



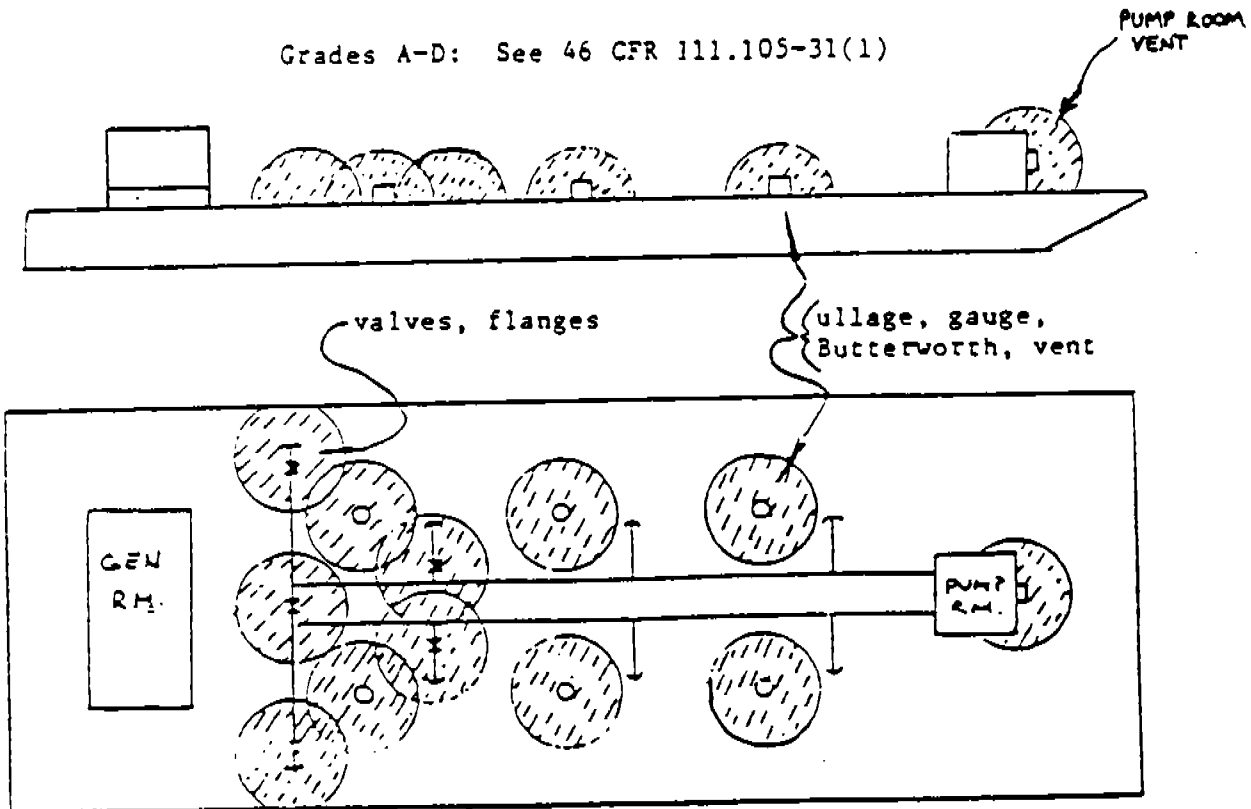
Equipment in cross-hatched areas must be explosionproof, watertight, Class 1, Division 1

See 46 CFR 111.105-31(1)



TANK BARGE WEATHERDECK CRITERIA

Grades A-D: See 46 CFR 111.105-31(1)



3-foot rule: Equipment in cross-hatched areas must be explosionproof, watertight Class 1, Division 1

**SPECIFIED HAZARDOUS LOCATIONS**

LOCATION	CLASS I DIV. 1	CLASS I DIV. 2	CLASS II	CLASS III
CARGO TANKS*	NA	NA	NA	NA
CARGO HANDLING ROOMS*	NA	NA	NA	NA
COFFERDAMS*	NA	NA	NA	NA
BATTERY ROOMS	X	NA	NA	NA
PAINT STORAGE ROOMS	X	NA	NA	NA
PAINT MIXING ROOMS	X	NA	NA	NA
OIL STORAGE ROOMS	X	NA	NA	NA
ANESTHETIC HANDLING AREA	X	NA	NA	NA
TANK VESSEL WEATHERDECK				
10 FT. RULE	X	NA	NA	NA
TANK VESSEL WEATHERDECK				
CARGO BLOCK	X	NA	NA	NA
FLAMMABLE GAS HANDLING				
ROOM*	NA	NA	NA	NA
FLAMMABLE LIQUID				
HANDLING ROOM*	NA	NA	NA	NA
ADJACENT TO CLASS I,				
DIV. 1 W/COMMUNICATION	X	NA	NA	NA
TANK VESSEL ENCLOSED SPACES				
ADJACENT TO CARGO TANK*	NA	NA	NA	NA
GRAIN HANDLING AREA	NA	NA	X	NA
COAL HANDLING AREA	NA	NA	X	NA
COAL PULVERIZING AREA	NA	NA	X	NA
CARPENTER SHOP	NA	NA	NA	X
FIBER HANDLING AREA	NA	NA	NA	X
VENT DUCT		SAME AS SPACE SERVED		
TANK VESSEL CARGO HOSE				
STOWAGE SPACE*	NA	NA	NA	NA
SPACE CONTAINING CARGO PIPING				
ONLY, ON TANK VESSELS*	NA	NA	NA	NA
LFG BARRIER SPACE*	NA	NA	NA	NA
ENCLOSED SPACE OPENING TO				
WEATHER DECK HAZ. AREA	X	NA	NA	NA
TANK VESSELS WITHIN 8' OF				
CARGO CONTAINMENT SYSTEM	X	NA	NA	NA
TANK VESSELS, WITHIN 10' OF				
CARGO HANDLING ROOM DOOR				
OR VENT	X	NA	NA	NA
VESSEL FUEL OIL TANKS,				
10' RULE DOES NOT APPLY	X	NA	NA	NA
TANK VESSEL, A-D CARGOES,				
AREA FROM 3m TO 5m OF				
PV VALVES	NA	(see SOLAS II-2/59.1.7.2) X	NA	NA
TANK VESSEL, A-D CARGOES,				
AREA FROM 3m TO 10m OF				
VENT OUTLETS FOR FREE				
FLOW OF VAPORS AND H.V.				
VENTS FOR LOADING OR				
DISCHARGE	NA	X	NA	NA

\* These areas are considered more hazardous than Class I, Division 1 and therefore carry specific requirements in 46 CFR 111.105-29, 111.105-31, and 111.105-32.

Coast Guard, DOT

air bell at any level up to the maximum allowed under paragraph (a) of this section.

(e) Each motor controller must be above the uppermost continuous deck. There must be a master switch at the controller and a master switch at the motor. The master switch at the motor must be disconnected from the circuit when the motor is started or stopped from the master switch at the controller.

(f) Each motor must be energized from the final emergency power source.

**Subpart 111.103—Remote Stopping Systems**

§ 111.103-1 Power ventilation systems except machinery space ventilation systems.

Each power ventilation system must have:

(a) A control to stop the ventilation that is:

- (1) Outside the space ventilated; and
- (2) Grouped with the controls for every power ventilation system to which this section is applicable; and

(b) In addition to the control required by paragraph (a), a stop control that is:

- (1) As far as practicable from the control required by paragraph (a) and grouped with the controls for every power ventilation system to which this section is applicable; or
- (2) The circuit breakers for ventilation grouped on the main switchboard and marked, "In Case of Fire Trip to Stop Ventilation."

NOTE: The requirements of this section do not apply to closed ventilation systems for motors or generators, diffuser fans for refrigerated spaces, room circulating fans, or exhaust fans for private toilets of an electrical rating comparable to that of a room circulating fan.

§ 111.103-2 Machinery space ventilation.

(a) Each machinery space ventilation system must have two controls to stop the ventilation, one of which may be the supply circuit breaker.

(b) The controls required in paragraph (a) of this section must be grouped so that they are operable

from two positions, one of which must be outside the machinery space.

§ 111.103-7 Ventilation stop stations.

Each ventilation stop station must:

(a) Be protected by an enclosure with a glass-paneled door on the front;

(b) Be marked, "In Case of Fire Break Glass and Operate Switch to Stop Ventilation;"

(c) Have the "stop" position of the switch clearly identified;

(d) Have a nameplate that identifies the system controlled; and

(e) Be arranged so that damage to the switch or cable automatically stops the equipment controlled.

§ 111.103-9 Machinery stop stations.

(a) Each forced draft fan, induced draft fan, blower of an inert gas system, fuel oil transfer pump, fuel oil unit, fuel oil service pump, and any other fuel oil pumps must have a stop control that is outside of the space containing the pump or fan.

(b) Each stop control must meet § 111.103-7.

**Subpart 111.105—Hazardous Locations**

§ 111.105-1 Applicability.

This subpart applies to installations in hazardous locations, as defined in the National Electrical Code.

NOTE: Chemicals and materials in addition to those listed in Table 500-2 of the National Electrical Code are listed in Subchapter Q of this chapter.

§ 111.105-5 National Electrical Code.

Each installation in a hazardous location must meet Articles 500 through 503 of the National Electrical Code, except:

(a) The first sentence of Sections 501-1, 502-1, and 503-1;

(b) Section 501-4, which § 111.105-15 replaces;

(c) Sections 502-14(a)(1) and 503-12 and each final sentence of Sections 502-4(a), 502-4(b), 503-3(a), and 503-3(b), which are replaced by § 111.105-17; and

(d) Section 502-14(a)(2), which § 111.105-35(d) modifies.



§ 111.105-7 Approved equipment.

If the National Electrical Code states that an item of electrical equipment is to be "approved," that item must be:

- (a) One that is listed by Underwriters Laboratories Inc., Factory Mutual Research Corp., or other independent laboratory recognized by the Commandant, for use in the hazardous location in which it is located; or
- (b) Purged and pressurized equipment that meets NFPA No. 496.

§ 111.105-9 Explosion-proof equipment.

Each item of electric equipment that is required under this subpart to be explosion-proof must be listed by Underwriters Laboratories Inc., Factory Mutual Research Corp., or other independent laboratory recognized by the Commandant, for use:

- (a) In a Class I Division 1 location;
- (b) With the Group of the cargo carried; and
- (c) In a Group B atmosphere, if the cargo is an inorganic acid.

[CGD 74-125A, 47 FR 15236, Apr. 8, 1982, as amended by CGD 82-096, 49 FR 4947, Feb. 9, 1984]

§ 111.105-10 Purged and pressurized equipment.

Purged and pressurized equipment must meet the requirements of NFPA No. 496.

§ 111.105-11 Intrinsically safe systems.

(a) If a rule in this subpart states that an electric system is to be intrinsically safe, the system must be listed as intrinsically safe by Underwriters Laboratories Inc., Factory Mutual Research Corp., or other independent laboratory recognized by the Commandant, for use in the hazardous location in which it is located.

- (b) Each electric cable for an intrinsically safe system must:
  - (1) Be 2 inches (50 mm) or more from cable of non-intrinsically safe circuits;
  - (2) Be partitioned by a grounded metal barrier from other non-intrinsically safe electric cables; or
  - (3) Be a shielded cable.
- (c) The manufacturer must submit installation instructions and restric-

tions on the approved system. Typical restrictions that must be specified include:

- (1) Voltage limitations;
- (2) Allowable cable parameters;
- (3) Maximum length of cable permitted; and
- (4) Ability of system to accept passive devices.
- (d) Intrinsically safe systems must not be interconnected unless the systems were approved with the particular arrangement.
- (e) The deck wiring diagram required by Part 110 of this subchapter must specify:
  - (1) System identification as to manufacturer's model number;
  - (2) System use;
  - (3) Cable parameter including length and type of cable;
  - (4) Wiring and equipment locations; and
  - (5) Installation details.

§ 111.105-15 Wiring methods for Class I hazardous locations.

(a) Cable for a Class I, Division 1, hazardous locations, and locations designated in §§ 111.105-31 and 111.105-32, except as provided in paragraphs (b) and (c) of this section must:

- (1) Be armored or MI type cable; and
- (2) Meet Subpart 111.60 of this chapter.
- (b) Cable for use in an intrinsically safe system must meet:
  - (1) Subpart 111.60 and § 111.105-11(b) of this chapter; and
  - (2) The recommendations of ISA RP 12.6 "Installation of Intrinsically Safe Instrument Systems in Class I Hazardous Locations," except Appendix A.1.
- (c) Flexible cords and cables must meet § 111.60-13 of this chapter.
- (d) Each explosion-proof enclosure that is in a Class I location must have an approved explosion-proof seal fitting that is:
  - (1) Treaded directly into the enclosure; or
  - (2) Connected to the enclosure by a piece of approved explosion-proof rigid metal conduit that is 18 inches (460 mm) or less in length.

§ 111.105-17 and Cla

- (a) Cableous locatio
- (1) Be a installed i cation; and
- (2) Meet
- (b) Each equipment hazardous tight term

§ 111.105-19

Each e each swit proof equi each ungre

§ 111.105-21

Each fan ous locati fan.

§ 111.105-23

Each ele ventilates be listed ries, Inc., Corp., or c ry recogniz the same c the ventila

- (a) Outsi
- (b) 10 ft.
- (c) In a n

§ 111.105-25

For the ventilation arduous spa that space.

§ 111.105-27

Each belt tion must h

- (a) A con
- (b) Pull equipment No. 77.

§ 111.105-29

riers. Each vess liquid carg point of 60 or higher n

em. Typical specified in

§ 111.105-17 Wiring methods for Class II and Class III hazardous locations.

(a) Cable for a Class II or III hazardous location must:

(1) Be armored or MI type cable if installed in a Division 1 hazardous location; and

(2) Meet Subpart 111.60 of this part.

(b) Each cable entrance to electric equipment in Class II and Class III hazardous locations must have a dust-tight terminal tube.

§ 111.105-19 Switches.

Each explosion-proof switch and each switch controlling explosion-proof equipment must have a pole for each ungrounded circuit conductor.

§ 111.105-21 Fans.

Each fan for ventilation of a hazardous location must be a nonsparking fan.

§ 111.105-23 Fan motors.

Each electric motor for a fan that ventilates a hazardous location must be listed by Underwriters Laboratories, Inc., Factory Mutual Research Corp., or other independent laboratory recognized by the Commandant, for the same class, division, and group as the ventilated location or be:

- (a) Outside the ventilation duct;
- (b) 10 ft. (3 m) from the ventilation duct termination; and
- (c) In a non-hazardous location.

§ 111.105-25 Ventilation ducts.

For the purpose of this subpart, a ventilation duct that ventilates a hazardous space has the classification of that space.

§ 111.105-27 Belt drives.

Each belt drive in a hazardous location must have:

- (a) A conductive belt; and
- (b) Pulleys, shafts, and driving equipment grounded to meet NFPA No. 77.

§ 111.105-29 Combustible liquid cargo carriers.

Each vessel that carries combustible liquid cargo with a closed-cup flashpoint of 60 degrees C (140 degrees F) or higher must have:

(a) Only intrinsically safe electric systems in cargo tanks; and

(b) No storage battery in any cargo handling room.

§ 111.105-31 Flammable or combustible cargo with a flashpoint below 60 degrees C (140 degrees F), liquid sulfur and inorganic acid carriers.

(a) *Applicability.* Each vessel that carries combustible or flammable cargo with a closed-cup flashpoint lower than 60 degrees C (140 degrees F) or liquid sulphur cargo, or inorganic acid cargo must meet the requirements of this section, except—

(1) A vessel carrying bulk liquefied flammable gases as a cargo, cargo residue, or vapor which must meet the requirements of § 111.105-32; and

(2) A vessel carrying carbon disulfide must have only intrinsically safe electric equipment in the locations listed in paragraphs (e) through (l) of this section.

(b) *Cable location.* Electric cable must be as close as practicable to the centerline and must be away from cargo tank openings.

(c) *Lighting circuits.* An enclosed hazardous space that has explosion-proof lighting fixtures must:

(1) Have at least two lighting branch circuits;

(2) Be arranged so that there is light for relamping any deenergized lighting circuit; and

(3) Not have the switch within the space for those spaces containing explosionproof lighting fixtures under paragraphs (g), (i) and (j) of this section.

(d) *Submerged cargo pump motors.* If a submerged cargo pump motor is in a cargo tank:

(1) Low liquid level, motor current, or pump discharge pressure must automatically shutdown power to the motor if the pump loses suction;

(2) An audible and visual alarm must be actuated by the shutdown of the motor; and

(3) There must be a lockable circuit breaker or lockable switch that disconnects power to the motor.

(e) *Cargo tanks.* A cargo tank must not contain any electric equipment except:

- (1) Intrinsically safe equipment;
- (2) Submerged cargo pumps; and
- (3) Supply cable for submerged cargo pumps.

(f) *Cargo handling rooms.* A cargo handling room must not have any electric cable or other electric equipment, except:

- (1) Intrinsically safe equipment;
- (2) Explosionproof lighting fixtures;
- (3) Cables supplying intrinsically safe equipment in the cargo handling room; and

(4) Armored or MI type cables that supply explosionproof lighting fixtures that are in the cargo handling room.

(g) *Lighting of cargo handling rooms.* Lighting for a cargo handling room except a cargo handling room under paragraph (h) of this section, must be lighted through fixed glass lenses in the bulkhead or overhead. Each fixed glass lens must be wire-inserted glass that is at least .025 inches (6.35 mm) thick and arranged to maintain the watertight and gastight integrity of the structure. The fixed glass lens may form a part of a listing fixture if the following are met:

(1) There is no access to the interior of the fixture from the cargo handling room.

(2) The fixture is vented to the engineroom or a similar nonhazardous area.

(3) The fixture is wired from outside the cargo handling room.

(4) The temperature on the cargo handling room surface of the glass lens, based on an ambient temperature of 40 degrees C, is not higher than 180 degrees C.

(h) A cargo handling room which precludes the lighting arrangement of paragraph (g) of this section, or where the lighting arrangement of paragraph (g) of the section does not give the required light, must have explosionproof lighting fixtures.

(i) *Enclosed spaces.* An enclosed space that is immediately above, below, or next to a cargo tank must not contain any electric equipment except equipment allowed for cargo handling rooms in paragraphs (f) and (g), and:

- (1) Through runs of armored or MI type cable; and

(2) Watertight enclosures with bolted and gasketed covers containing only:

- (i) Depth sounding devices;
- (ii) Log devices; and
- (iii) Impressed-current cathodic protection system electrodes.

(j) *Cargo hose stowage space.* A cargo hose stowage space must not have any electric equipment except explosionproof lighting fixtures and through runs of armored or MI type cable.

(k) *Cargo piping in a space.* A space that has cargo piping must not have any electrical equipment except explosionproof lighting fixtures and through runs of armored or MI type cable.

(l) *Weather locations.* A location in the weather, except on an inorganic acid carrier, must have only explosionproof electrical equipment, purged and pressurized equipment, and through runs of armored or MI type cable if it is—

- (1) Within 10 feet (3 m) of:
  - (i) A cargo tank vent outlet;
  - (ii) A cargo tank ullage opening;
  - (iii) A cargo pipe flange;
  - (iv) A cargo valve;
  - (v) A cargo handling room entrance;
- or
- (vi) A cargo handling room ventilation opening; or

(2) On a tankship and on the open deck over the cargo area and 10 feet (3 m) forward and aft of the cargo area on the open deck and up to 8 feet (2.4 m) above the deck.

(m) *Other spaces.* Except for those spaces listed in paragraphs (e) through (k), a space that has a direct opening to any space listed in paragraphs (e) through (l) must have only the electric installations that are allowed for the space to which it opens.

[CGD 74-125A, 47 FR 15236, Apr. 8, 1982, as amended by CGD 82-096, 49 FR 4947, Feb. 9, 1984]

§ 111.105-32 Bulk liquefied gas and ammonia carriers.

(a) Each vessel that carries bulk liquefied flammable gases or ammonia as a cargo, cargo residue, or vapor must meet the requirements of this section.

(b) As used in this section:

(1) The "dangerous" in § 154.7 of

(2) The not include ammonia c

(c) Each motor inst by the Com

(d) Electr installed in zone, excep

(1) Intrin ment and v

(2) Othe this section

(e) A sub if installed following r

(1) Low or pump di matically pump mot

(2) Ther visual alar tion that a down unde paragraph

(3) Ther breaker or nects the p

(f) Elect installed i tank that i ondry ba chapter, ex

(1) Thro type cable.

(2) Expl

(3) Dept tight enclo

(4) Log sures;

(5) Impi tection sy enclosures

(6) Arm submerged

(g) Elect installed i by a gast hold spac have a sec quirement ter, excep

(1) Thro type cable

(2) Exp

276

Coast Guard, DOT

(1) The terms "gas-safe" and "gas-dangerous" spaces are used as defined in § 154.7 of this chapter.

(2) The term "gas-dangerous" does not include the weather deck of an ammonia carrier.

(c) Each submerged cargo pump motor installation must be approved by the Commandant.

(d) Electrical equipment must not be installed in a gas-dangerous space or zone, except:

(1) Intrinsically safe electrical equipment and wiring, and

(2) Other equipment as allowed in this section.

(e) A submerged cargo pump motor, if installed in a tank, must meet the following requirements:

(1) Low liquid level, motor current, or pump discharge pressure must automatically shut down power to the pump motor if the pump loses suction.

(2) There must be an audible and visual alarm at the cargo-control station that activates if the motor shuts down under the requirements of subparagraph (1) of this paragraph.

(3) There must be a lockable circuit breaker or lockable switch that disconnects the power to the motor.

(f) Electrical equipment must not be installed in a hold space that has a tank that is not required to have a secondary barrier under § 154.459 of this chapter, except:

(1) Through runs of armored or MI type cable;

(2) Explosionproof lighting fixtures;

(3) Depth sounding devices in gastight enclosures;

(4) Log devices in gastight enclosures;

(5) Impressed current cathodic protection system electrodes in gastight enclosures; and

(6) Armored or MI type cable for a submerged cargo pump motor.

(g) Electrical equipment must not be installed in a space that is separated by a gastight steel boundary from a hold space that has a tank that must have a secondary barrier under the requirements of § 154.459 of this chapter, except:

(1) Through runs of armored or MI type cable;

(2) Explosionproof lighting fixtures;

(3) Depth sounding devices in gastight enclosures;

(4) Log devices in gastight enclosures;

(5) Impressed current cathodic protection system electrodes in gastight enclosures;

(6) Explosionproof motors that operate cargo system valves or ballast system valves;

(7) Explosionproof bells for general alarm systems; and

(8) Armored or MI type cable for a submerged cargo pump motor.

(h) A cargo-handling room must not have any installed electrical equipment, except explosionproof lighting fixtures.

(i) A space for cargo hose storage or a space that has cargo piping must not have any installed electrical equipment, except:

(1) Explosionproof lighting fixtures; and

(2) Through runs of armored or MI type cable.

(j) A gas dangerous zone on the open deck must not have any installed electrical equipment, except:

(1) Explosionproof equipment that is necessary for the operation of the vessel; and

(2) Through runs of armored or MI type cable.

(k) A space, except those named in paragraphs (f) through (i) of this section, that has a direct opening to gas-dangerous spaces or zones must have no electrical equipment except as allowed in the gas-dangerous space or zone.

(1) Each gas-dangerous space that has lighting fixtures must have at least two branch circuits for lighting.

(m) Each switch and each overcurrent protective device for any lighting circuit that is in a gas-dangerous space must open all conductors of the circuit simultaneously.

(n) Each switch and each overcurrent protective device for lighting in a gas-dangerous space must be in a gas-safe space.

[CGD 74-125A, 47 FR 15236, Apr. 8, 1982, as amended by CGD 77-069, 52 FR 31626, Aug. 21, 1987]

§ 111.105-33 Mobile offshore drilling units.

(a) *Applicability.* This section applies to each mobile offshore drilling unit.

(b) *Definitions.* As used in this section:

(1) "Enclosed spaces" are locations delineated by floors, bulkheads, or decks which may have doors or windows.

(2) "Semi-enclosed spaces" are locations where natural conditions of ventilation are notably different from those on open deck due to the presence of structures such as roofs, windbreaks, and bulkheads which are so arranged that dispersion of gas may not occur.

(c) The internal space of each pressure vessel, tank, and pipe for drilling mud and for gas venting must have only intrinsically safe electric equipment.

(d) The following are Class I, Division 1 locations:

(1) An enclosed space that contains any part of the mud circulating system that has an opening into the space and is between the well and final degassing discharge.

(2) An enclosed or semi-enclosed location that is below the drill floor and contains a possible source of gas release such as the top of a drilling nipple.

(3) An enclosed space that is on the drill floor and is not separated by a solid, gas-tight floor from the spaces specified in paragraph (d)(2) of this section.

(4) A space that would normally be considered a Division 2 location under paragraph (e) of this section but where combustible or flammable gases might accumulate. This could include pits, ducts, and similar structures downstream of the final degassing discharge.

(5) A location in the weather or a semi-enclosed location, except as provided in paragraph (d)(2) of this section, that is within 5 feet (1.5 m) of the boundary of any:

(i) Equipment or opening specified in paragraph (d)(1) of this section;

(ii) Ventilation outlet, access, or other opening to a Class I, Division 1 space; or

(iii) Gas vent outlet.

(6) Except as provided in paragraph (f) of this section, an enclosed space that has an opening into a Class I, Division 1 location.

(e) The following are Class I, Division 2 locations:

(1) An enclosed space that has any open portion of the mud circulating system from the final degassing discharge to the mud suction connection at the mud pit.

(2) A location in the weather that is:

(i) Within the boundaries of the drilling derrick up to a height of 10 feet (3m) above the drill floor;

(ii) Below the drill floor and within a radius of 10 feet (3m) of a possible source of release, such as the top of a drilling nipple; or

(iii) Within 5 feet (1.5m) of the boundaries of any ventilation outlet, access, or other opening to a Class I, Division 2 space.

(3) A location that is:

(i) Within 5 feet (1.5m) of a semi-enclosed Class I, Division 1 location indicated in paragraph (d)(2) of this section; or

(ii) Within 5 feet (1.5m) of a Class I, Division 1 space indicated in paragraph (d)(5).

(4) A semi-enclosed area that is below and contiguous with the drill floor to the boundaries of the derrick or to the extent of any enclosure which is liable to trap gases.

(5) A semi-enclosed derrick to the extent of its enclosure above the drill floor, or to a height of 10 feet (3m) above the drill floor, whichever is greater.

(6) Except as provided in paragraph (f) of this section, an enclosed space that has an opening into a Class I, Division 2 location.

(f) An enclosed space that has direct access to a Division 1 or Division 2 location is the same division as that location, except:

(1) An enclosed space that has direct access to a Division 1 location is not a hazardous location if:

(i) The access has self-closing gas-tight doors that form an air lock;

(ii) The ventilation causes greater pressure in the space than in the Division 1 location; and

(iii) Loss of is alarmed at

(2) An enclosed access to a D considered as

(i) The access tight door that and that has

(ii) Ventilation with the door into the Division

(iii) Loss of a manned crew

(3) An enclosed access to a D hazardous location

(i) The access tight door that and that has

(ii) Ventilation with the door into the Division

(iii) Loss of alarm at a man

(g) Electric installed in s

ous by the m graph (f) of t ed to essential

§ 111.105-35

(a) The fol sion 1 locatio bituminous c

(1) The int cargo hold.

(2) Each coal transfe dropped or di

(3) Each of m) of a coal is dropped or

(b) Each sp veyer on a v nous coal is space.

(c) Each graphs (a) an sion 1 locatio anthracitic c

(d) A space on a vessel coal must h approved for

ardous locat general alarm

(iii) Loss of ventilation overpressure is alarmed at a manned station;

(2) An enclosed space that has direct access to a Division 1 location can be considered as a Division 2 location if:

(i) The access has a self-closing, gas-tight door that opens into the space and that has no hold-back device;

(ii) Ventilation causes the air to flow with the door open from the space into the Division 1 location; and

(iii) Loss of ventilation is alarmed at a manned control station; and

(3) An enclosed space that has direct access to a Division 2 location is not a hazardous location if:

(i) The access has a self-closing, gas-tight door that opens into the space and that has no hold-back device;

(ii) Ventilation causes the air to flow with the door open from the space into the Division 2 location; and

(iii) Loss of ventilation actuates an alarm at a manned control station.

(g) Electrical equipment and devices installed in spaces made non-hazardous by the methods indicated in paragraph (f) of this section must be limited to essential equipment.

§ 111.105-35 Vessels carrying coal.

(a) The following are Class II, Division 1 locations on a vessel that carries bituminous coal:

(1) The interior of each coal bin and cargo hold.

(2) Each compartment that has a coal transfer point where coal is dropped or dumped.

(3) Each open area within 10 feet (3 m) of a coal transfer point where coal is dropped or dumped.

(b) Each space that has a coal conveyor on a vessel that carries bituminous coal is a Class II, Division 2 space.

(c) Each location listed in paragraphs (a) and (b) is a Class II, Division 1 location on a vessel that carries anthracitic coal.

(d) A space that has a coal conveyor on a vessel that carries bituminous coal must have electrical equipment approved for Class II, Division 2 hazardous locations, except watertight general alarm bells.

§ 111.105-37 Flammable anesthetics.

Each electric installation where a flammable anesthetic is used or stored must meet NFPA No. 56A.

§ 111.105-39 Gasoline or other highly volatile motor fuel carried in vehicles.

(a) *Applicability.* This section applies to spaces that are "specially suitable for vehicles" as defined in §§ 70.10-44 and 90.10-38 of this chapter.

(b) *General requirements.* Electric equipment which is within 18 inches (460 mm) of the deck must meet Article 501 of the National Electrical Code for Class I, Division 2, Group D locations. Electric equipment which is 18 inches (460 mm) or more above the deck must be totally enclosed or be drip-proof, and protected by guards or screens to prevent escape of sparks or metal particles.

(c) *Loss of ventilation alarm.* Loss of ventilation in a space that is "specially suitable for vehicles" must actuate an audible and visual alarm at a manned location.

§ 111.105-41 Battery rooms.

Each electric installation in a battery room must meet Subpart 111.15 of this chapter.

§ 111.105-43 Paint stowage or mixing spaces.

A space for the stowage or mixing of paint must not have any electric equipment, except:

(a) Intrinsically safe electric equipment approved for a Class I, Division 1, Group D location;

(b) Explosionproof electric equipment approved for a Class I, Division 1, Group D location; or

(c) Through runs of armored or MI type cable.

Subpart 111.107—Industrial Systems

§ 111.107-1 Industrial systems.

(a) A system on a mobile offshore drilling unit that is used only for the industrial function of the unit and meets the National Electrical Code must meet only the following requirements in this subchapter:

Appendix C

List of Sample Survey Reports

DATE	NO.	STBD	C.O.	TANK	EXXON	NORTH	SLOPE
22/8/1991	FR. 43,	SL-42	→ RENEW F.P.	80"	-	WEB DRILL STOPPER ON AFT SIDE	
	"	SL-43	- " "	40"	-	" " " " " "	
	FR. 50,	SL-40	- " "	40"	-	" " " ON BOTH SIDE	
	FR. 49,	SL-40	- " "	40"	-	" " " ON AFT SIDE	
	FR. 48,	SL-42	- RENEW F.P & WEB		AS PER EXXON SKETCH 2,		
	FR. 47,	SL-45	- " " "	"	"	" " " "	
	"	SL-43	- RENEW F.P	40"	-	WEB DRILL STOPPER ON BOTH SIDE	
✓ CHECK IN SHELL	"	SL-42	- RENEW F.P & WEB		AS PER EXXON SKETCH 2,		
	"	SL-41	- " " "	"	"	" " " "	
	FR. 46	SL-45	- " " "	"	"	" " " "	
	"	SL-43	- " " "	"	"	" " " "	
	"	SL-42	- " " "	"	"	" " " "	
	"	SL-40	- RENEW F.P	40"	-	WEB DRILL STOPPER ON AFT SIDE	
	FR. 45	SL-40	- " " "	"	-	" " " " " "	
	"	SL-42	- RENEW F.P & WEB		AS PER EXXON SKETCH 2,		
	"	SL-43	- RENEW F.P.	40"	-	WEB DRILL STOPPER ON AFT SIDE	
✗	FR. 50,	SL- <del>39</del>	- WEB DRILL STOPPER			ON AFT SIDE	
	"	SL-49	- <del>WEB DRILL STOPPER</del>			<del>ON AFT SIDE</del>	
	"	SL-39	- RENEW F.P.	40"	-	WEB DRILL STOPPER ON AFT SIDE	
	FR. 49,	SL-37	- WEB DRILL STOPPER			ON AFT SIDE.	
	FR. 48,	SL-39	- RENEW F.P	40"	-	WEB DRILL STOPPER ON AFT SIDE	
	FR. 47,	SL-39	- RENEW F.P.	40"	-	WEB DRILL STOPPER ON AFT SIDE	

SS GOLDEN GATE TANK FRACTURE REPORT (JUNE, 1991)

TANK	FRM	LOCATION	MBR FRACTURED	LENGTH	CLASS	ZONE
1B	91	1ST BHD LONG'L	LONG'L	4"	2	4
LONG'L FRACTURE AT O/T BHD. VEE OUT/REWELD.						
2P	91	LONG'L 29P	LONG'L	4"	2	1
LONG'L FRACTURE AT O/T BHD. VEE OUT / REWELD.						
2P	90	LONG'L 18P	LONG'L	18"	2	3
LONG'L FRACTURE TO HORIZONTAL STRINGER. VEE OUT / REWELD. 6' STAGING.						
2P	85	L/B	WEB FRAME	12"	2	4
LAF PLATE AT WEB FRACTURE. VEE OUT / REWELD.						
2P	90	L/B	LONG'L	10"	2	4
LONG'L FRACTURE TO HORIZONTAL STRINGER. VEE OUT / REWELD. 6' STAGING.						
2P	90-91	L/B	LONG'L	6"	2	4
LONG'L FRACTURE TO HORIZONTAL STRINGER. VEE OUT / REWELD. 6' STAGING.						
2P	90	L/B	LONG'L		2	4
LONG'L FRACTURE TO 2ND HORIZONTAL STRINGER. VEE OUT / REWELD.						
2P	90	LONG'L 15P	LONG'L		2	3
LONG'L FRACTURE TO 2ND HORIZONTAL STRINGER. VEE OUT / REWELD.						
2P	91	LONG'L 13P	LONG'L		2	3
LONG'L PEN THROUGH O/T BHD. VEE OUT / REWELD BOTH SIDES.						
2P	91	LONG'L 12P	LONG'L		2	3
LONG'L PEN THROUGH O/T BHD. VEE OUT / REWELD BOTH SIDES.						
2P	91	LONG'L 10P	LONG'L		2	3
LONG'L PEN THROUGH O/T BHD. VEE OUT / REWELD BOTH SIDES.						
2P	91	BHD LONG'L 10	LONG'L		2	4
BHD LONG'L PEN THROUGH O/T BHD. VEE OUT / REWELD BOTH SIDES.						
2P	91	BHD LONG'L 9	STIFF		3	4
STIFF BETWEEN BHD LONG'L AND VERT STRING FRACTURED AT BHD LONG'L 9. REWELD.						
2P	91	LONG'L 26P	LONG'L	2"	2	4
LONG'L PEN LEAKING AT O/T BHD. VEE OUT / REWELD BOTH SIDES. EXISTING STAGING.						
2P	91	LONG'L 28P	LONG'L	2"	2	4
LONG'L PEN LEAKING AT O/T BHD. VEE OUT / REWELD BOTH SIDES. EXISTING STAGING.						
2P	90	L/B	LONG'L	10"	2	4
LONG'L FRACTURE TO HORIZONTAL STRINGER. VEE OUT / REWELD. 6' STAGING.						



## S.S. KENAI

## Item #32- Tank Internal Inspection

## No.1 Port Center Cargo Tank

1. Gouge & reweld two(2) 3" fractures (each side - 12" total) in 3rd panel stringer below main deck at fwd bkhd #100. Both fractures extend from rathole at innershell located 6'ft aft of fwd bkhd #100.
2. Gouge & reweld two(2) 3" fractures (each side - 6" total) in 4th panel stringer below main deck at fwd bkhd #100. Both fractures extend from rathole at innershell located 6'ft aft of fwd bkhd #100.
3. Gouge & reweld two(2) 2" fractures (each side - 8" total) in bottom panel stringer at fwd bhd #100. Both fractures extend from rathole at innershell located 6'ft aft of fwd bkhd #100
4. At 2nd panel stringer below main deck on swash bkhd #96, gouge & reweld a 6" fracture (each side - 12" total) in weld connecting 1st horz. flatbar stiffener above stringer to vert. swash bkhd stiffener located 6'ft inbd of innershell.

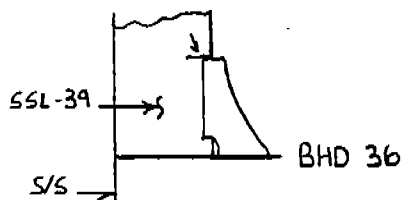
NOTE- 10'ft to 15'ft of staging will be required in way of gaining access to the above fracture repairs.

## Additions

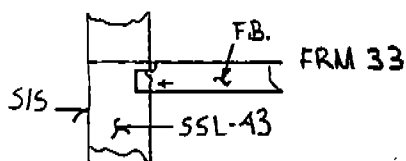
1. Gouge & reweld a 3" fracture (each side - 6" total) in 4th panel stringer below main deck at fwd bkhd #100. Fracture extends from rathole at innershell located at fwd bkhd.
2. Gouge & reweld a 4" fracture (each side - 8" total) in bottom panel stringer at fwd bkhd #100. Fracture extends from rathole at CL long. bkhd & fwd bkhd.
3. Gouge & reweld a 10'ft fracture (each side - 20'ft total) in weld connecting 1st horz. bkhd stiffener above 2nd panel stringer (below main deck) to swash bkhd #96. Fracture is located appx. 12' to 22'ft off CL long. bkhd.

S/S SIDE FRACTURES

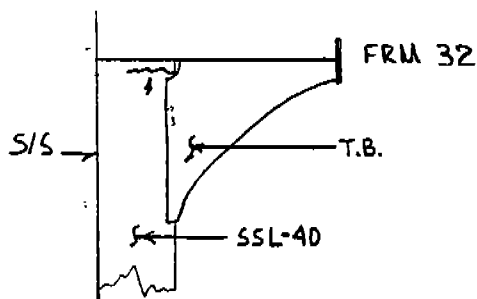
SSL-39 Fractured 3 1/2" Fwd of BHD36  
e BKT attachment.



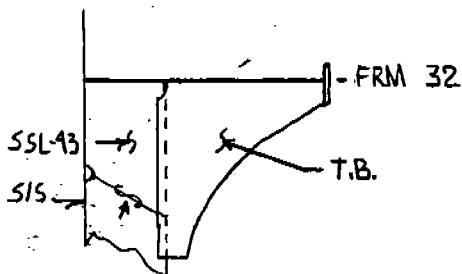
F.B. Fractured 4" @ attachment to SSL-43  
Aft side of Frm. 33.



SSL-40 Fractured Web 7" aft of Frm. 32

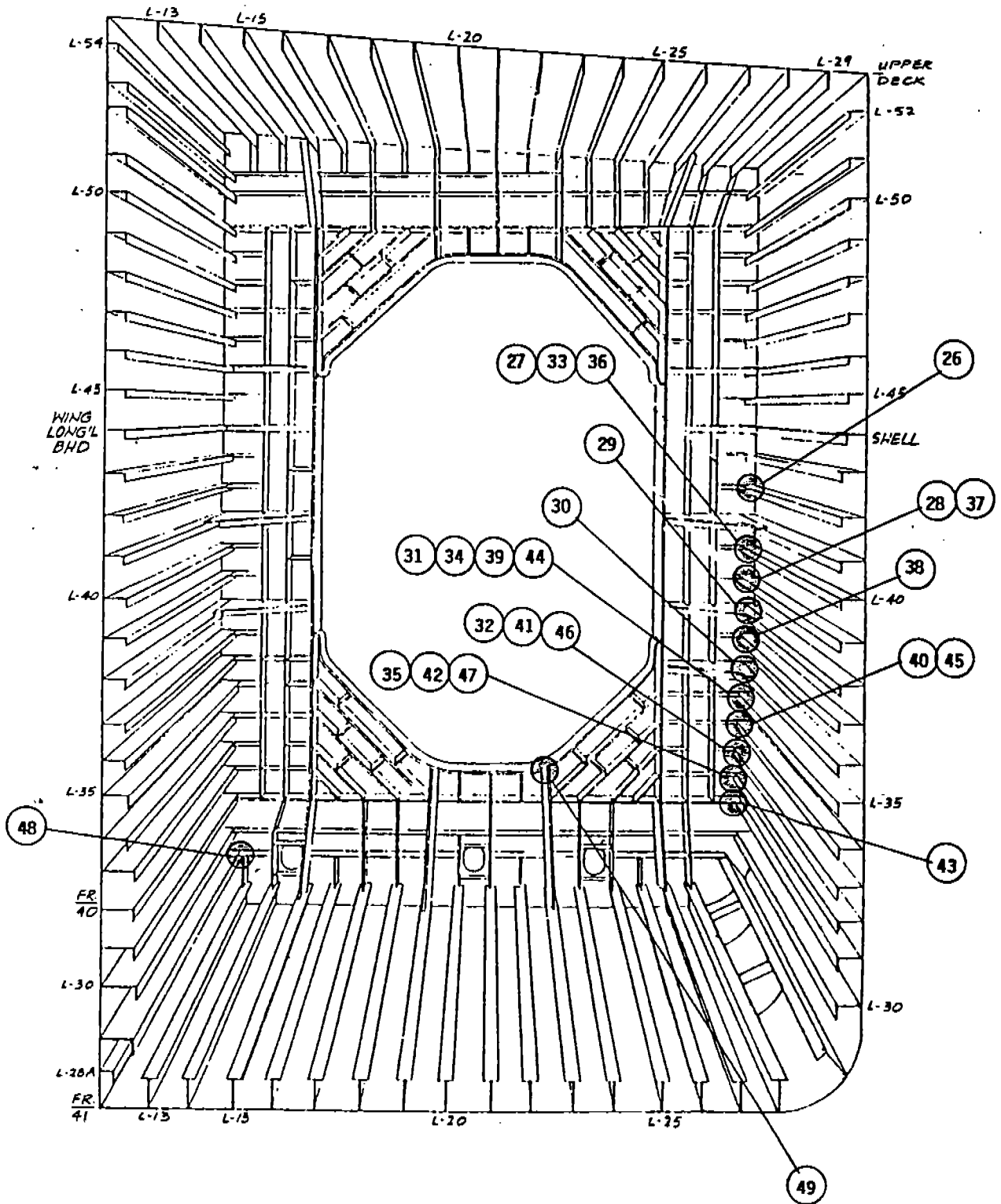


SSL-43 Missing 16" of Weld on Web Aft of Frm 32



VESSEL NAME: THOMPSON PASS		INDICATE ON DRAWING: <input type="checkbox"/> ORIGINAL THICKNESS	
TITLE: Fractures @ S/S No.1 Port Wing TK		<input type="checkbox"/> WELD LOCATIONS <input type="checkbox"/> FRAME NUMBERS <input type="checkbox"/> ORIENTATION	
LOOKING: Plan View	TANK #: IP	DATE: 08-19-91	
DRAWN BY: M. STRAIGHT	WR#: P-776	PAGE 1 OF 5	

S.S. "EXXON NORTH SLOPE"  
 NO. 2 STBD W.B. WING TANK  
 TRANSVERSE WEB FRAME 40



LOOKING FORWARD

284

# ULTRATEST

S.S. "EXXON NORTH SLOPE"

## #2 STBD W.B. WING TANK

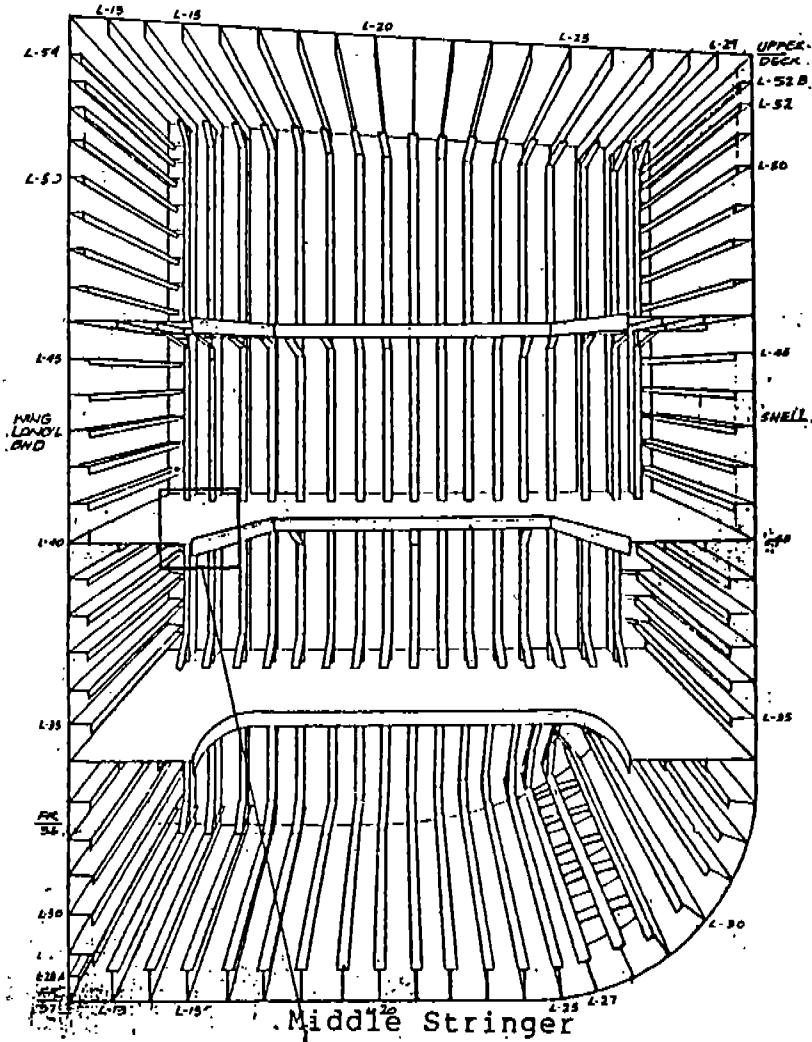
### WEB FRAME 39

20. SL-37, Flatbar weld toe fractured. Aft of frame.
21. SL-36, 2" Web fractured. Aft of frame.
22. SL-35, 1 1/2" Web fractured. Aft of frame.
23. SL-34, 3" Web fractured. Aft of frame.
24. SL-33, 2" Flatbar weld toe fractured. Aft of frame.
25. SL-32, 1 1/2" Flatbar weld toe fractured. Aft of frame.

### WEB FRAME 40

26. SL-42, 1" Flatbar weld toe fractured. Aft of frame.
27. SL-40, 1/2" Web plate and 1/2" Lug edge fractured. At web frame.
28. SL-39, 1 1/2" Web plate and 1/2" Lug edge fractured. At web frame.
29. SL-38, 1 1/2" Web plate and 1/2" Lug edge fractured. At web frame.
30. SL-36, 1" x 1" Web plate and 1/2" Lug edge fractured. At web frame.
31. SL-35, 1 1/2" x 1" Web plate and 1/2" Lug edge fractured. At web frame.
32. SL-33, 1" Web plate fractured. At web frame.
33. SL-40, 2" Bracket fractured. Aft of frame.
34. SL-35, 1 1/2" Weld connection fractured. At web frame.
35. SL-32, 1 1/2" Weld connection fractured. At web frame.
36. SL-40, 3" Web fractured. Aft of frame.
37. SL-39, 3" Web fractured. Aft of frame.
38. SL-37, 2" Flatbar weld toe fractured. Aft of frame.
39. SL-35, 2" Web fractured. Aft of frame.
40. SL-34, 2" Web fractured. Aft of frame.
41. SL-33, 3" Flatbar weld toe fractured. Aft of frame.

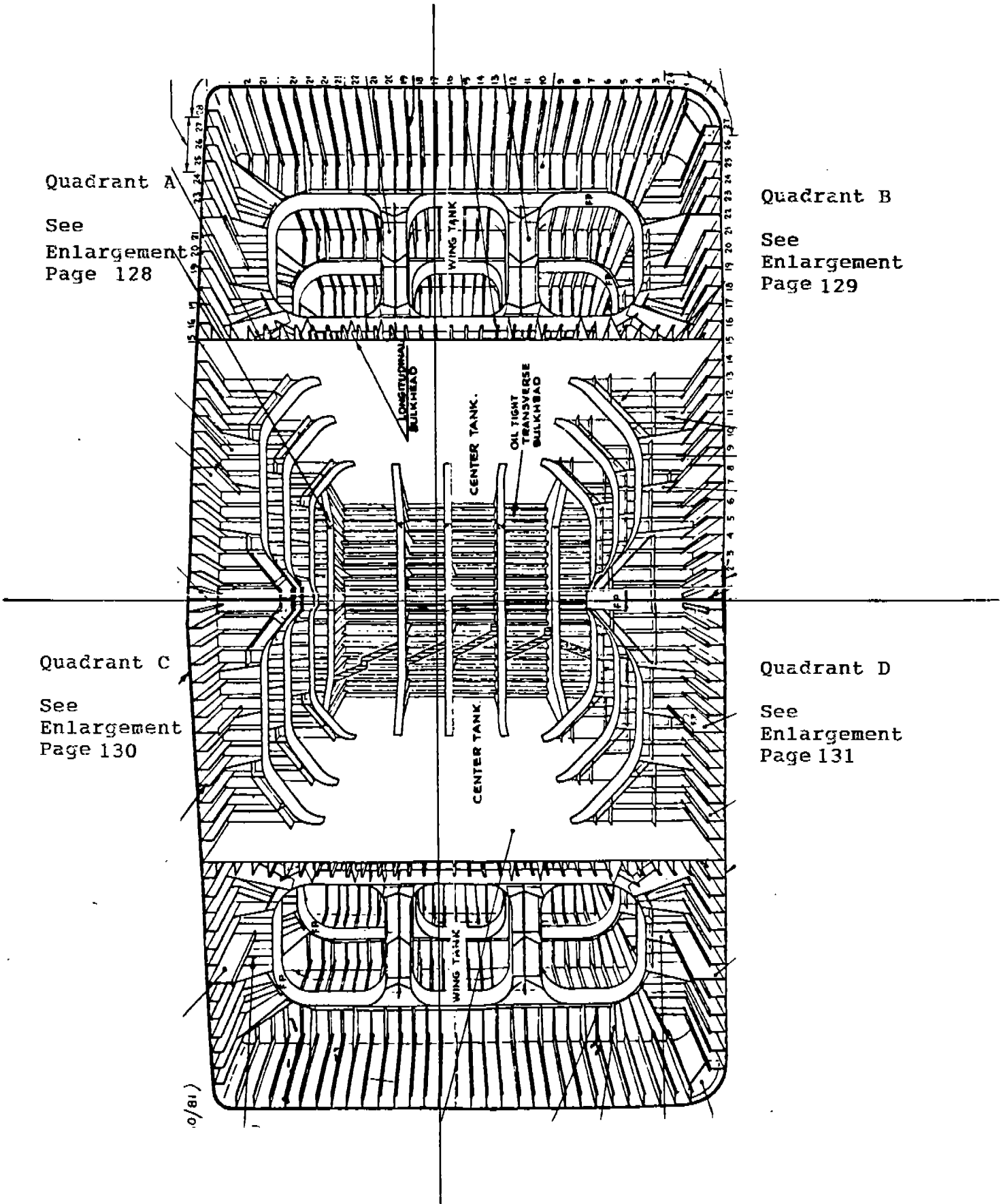
S.S. "EXXON NORTH SLOPE"  
NO. 2 STBD WING W.B. TANK  
TRANSVERSE BHD. 36



General condition on area below the Middle Stringer.

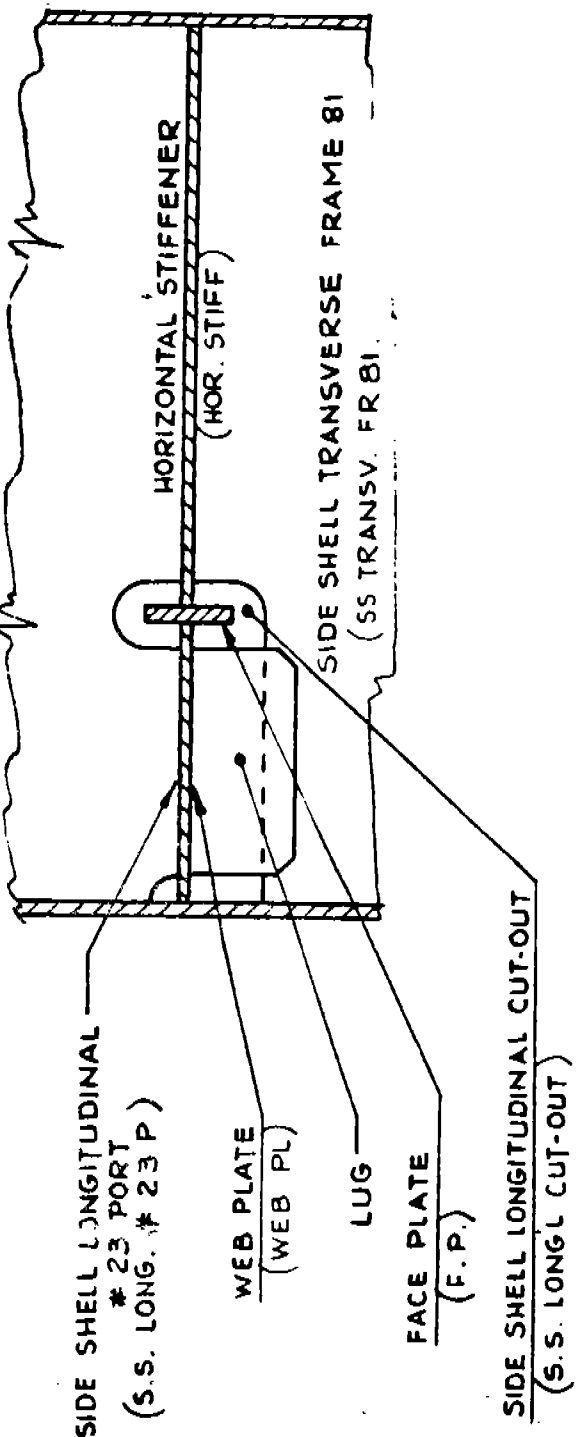
Appendix D

Typical Tank Nomenclature



NOTE: FRAME NUMBERS ARE TYPICAL FOR PURPOSE, DETAILS, LOCATION

Quadrant A



DECK CENTERLINE STRAKE BETWEEN FRAMES 80 & 81  
(DK CL STRK - FRS 80/81)

DECK PLATING BETWEEN FRAMES 80 & 81  
(DK PLTG. - FRS 80/81)

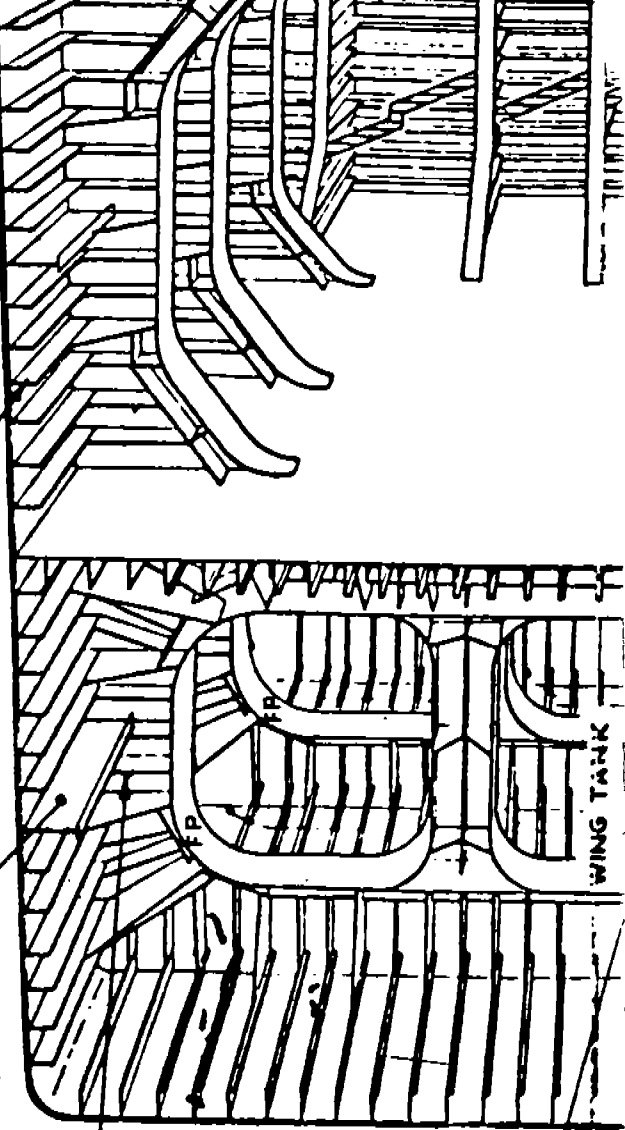
DECK LONGITUDINAL # 11 PORT BETWEEN FRAMES 80 & 81  
(DK LONG # 11 P - FRS 80/81)

DECK GIRDER # 22 PORT BETWEEN FRAMES 80 & 81  
(DK GRDR # 22 P - FRS 80/81)

VERTICAL FLAT BAR STIFFENER # 23 ON DECK TRANSVERSE PORT FRAME 81  
(VERT FB STIFF ON DECK TRANS P-FR 81)

NOTE: F.P. = FACE PLATE.

LONGITUDINAL BULKHEAD PORT BETWEEN FRAMES 80 & 81  
(LONG'L BHD P - FRS 80 & 81)



288

MEMBERS SHOWN ON THIS DRAWING  
AND GIVEN FOR DESCRIPTIVE  
PURPOSES. WHEN REFERRING TO STRUCTURAL  
MEMBERS, USE ACTUAL FRAME NUMBERS FOR  
DESCRIPTION.

DECK CENTERLINE GIRDER BETWEEN FRAMES 80 & 81  
(DK  $\Phi$  GRDR - FRS 80/81)  
DECK GIRDER # 8 STARBOARD BETWEEN FRAMES 80 & 81  
(DK GRDR # 8 S - FRS 80/81)  
DECK TRANSVERSE FRAME 81  
(DK TRANSV. FR 81)

HORIZONTAL STRINGER # 5 ON TRANSVERSE BULKHEAD  
(HOR. STRGR # 5 ON TRANSV. BHD FR. 84.) FRAME 84.

LONGITUDINAL BULKHEAD STARBOARD BETWEEN FRAMES  
(LONG'L BHD S - FRS 80/81) 80 & 81

STRINGER PLATE STARBOARD BETWEEN FRAMES 80 & 81  
(STRGR PLS - FRS 80/81)

ROUNDED GUNWALE PLATE STARBOARD BETWEEN  
FRAMES 80 & 81  
ROUND GNWL PL 5 - FRS 80/81

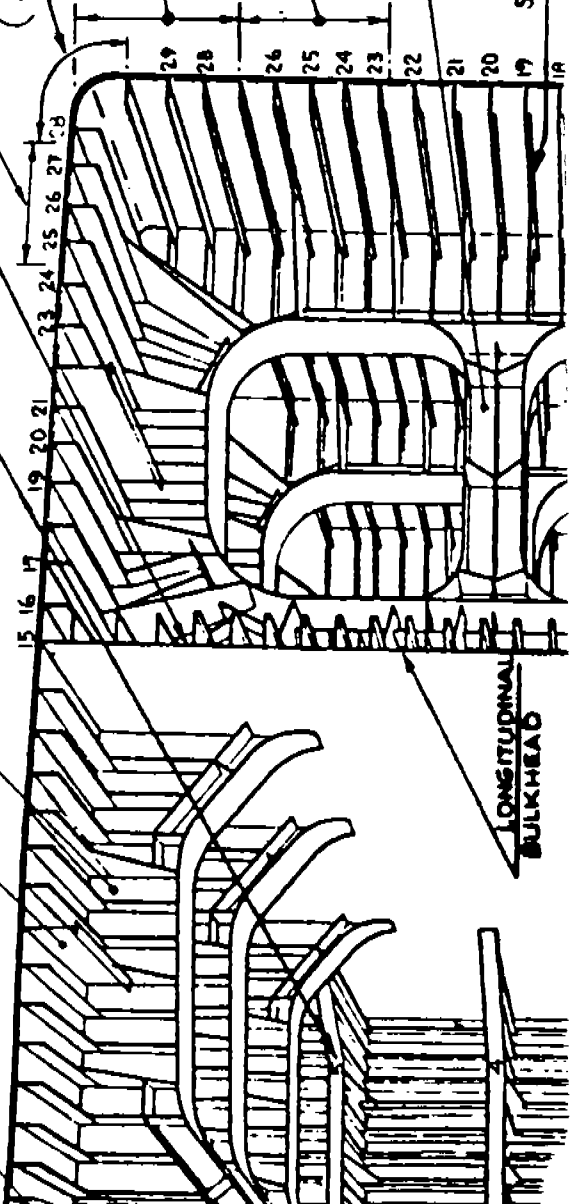
SHEER STRAKE STARBOARD BETWEEN FRAMES 80 & 81  
(SHR STR S - FRS 80/81)

TOPSIDE STRAKE STARBOARD BETWEEN FRAMES 80 & 81  
(TOPSIDE STR. S - FRS 80/81)

UPPER STRUT STARBOARD FRAME 81  
(UPPR STRUT S - FR 81)

SIDE SHELL LONGITUDINAL # 17 STARBOARD BETWEEN ETC.  
(SIDE SHELL LONG'L # 17 S - FRS 80/81)

289



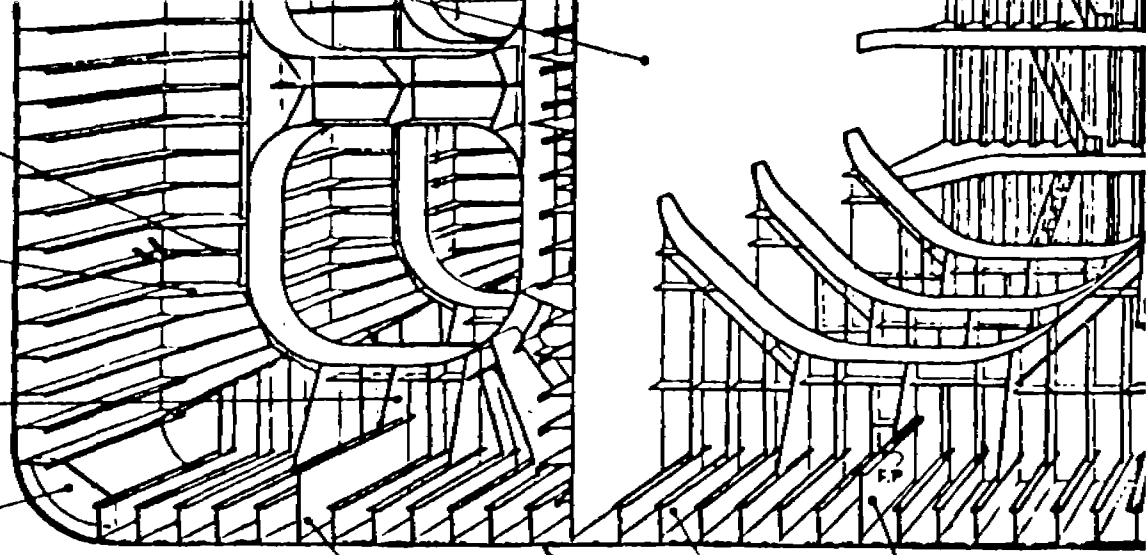


HORIZONTAL FLAT BAR STIFFENER #6 ON  
SIDE SHELL TRANSVERSE PORT FRAME 81  
(HOR. F.B STIFF ON SS TRANSV. P-FR 81)

HORIZONTAL BRACKET #5 ON SIDE SHELL  
TRANSVERSE PORT FRAME 81  
(HOR BKT #5 ON SS TRANSV. P-FR 81)

LONGITUDINAL BRACKET #22 PORT ON  
BOTTOM TRANSVERSE FRAME 81  
(LONG'L BKT #22 P ON BTM TRANSV. FR 81)

BILGE BRACKET BETWEEN PORT FRAMES 80 & 81  
(BLG BKT P - FR 80/81)



BOTTOM GIRDER FACE PLATE

BOTTOM GIRDER WEB PLATE

130

VERTICAL STIFFENER  
FR 83 ON BOTTOM  
GIRDER

LOWER LONGITUDINAL ON  
BOTTOM GIRDER



BOTTOM PLATING

BOTTOM GIRDER DETAIL

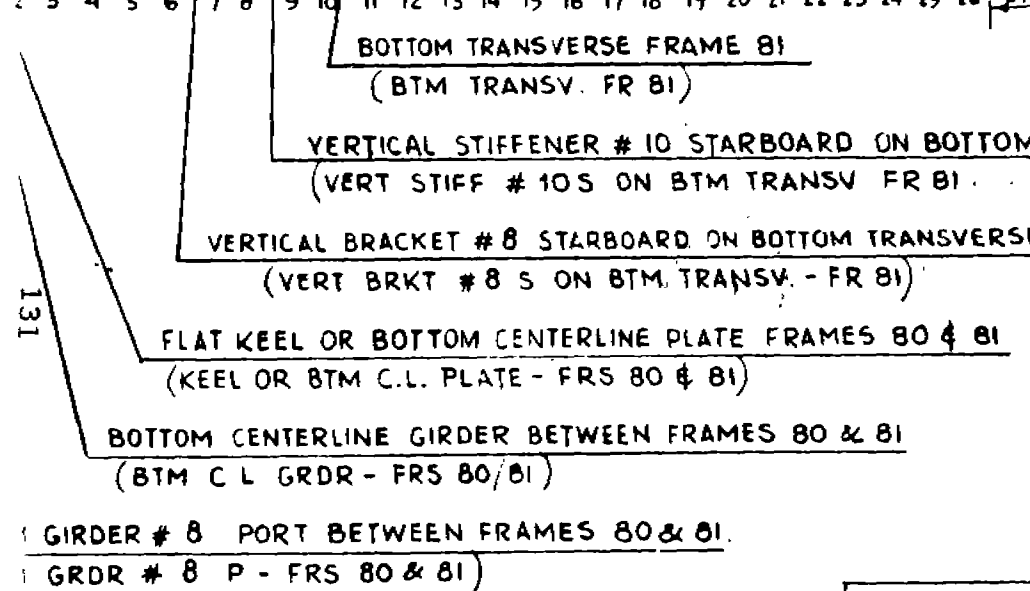
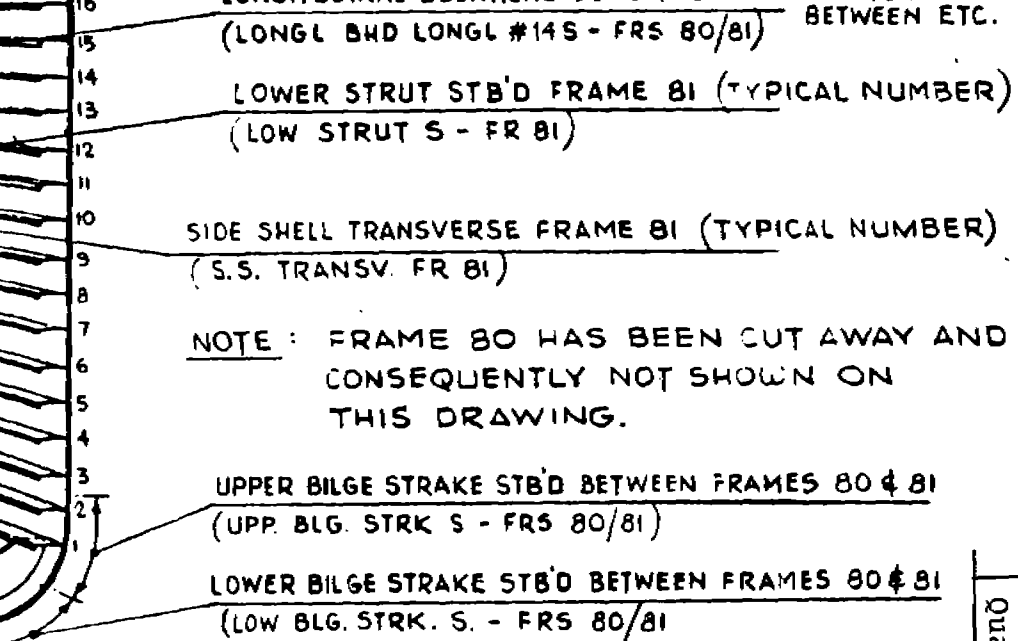
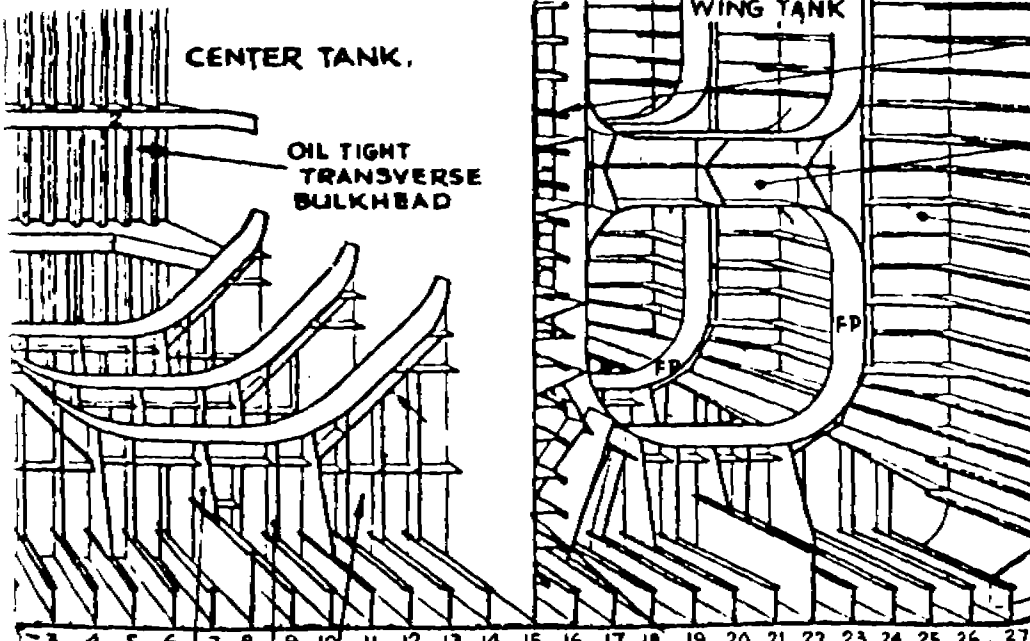
BOTTOM GIRDER #22 PORT BETWEEN FRAMES 80 & 81  
(BTM GRDR #22 P - FRS 80/81)

BOTTOM PLATING PORT BETWEEN FRAMES 80 & 81  
(BTM PLTG P - FRS 80/81)

BOTTOM LONGITUDINAL #13 PORT BETWEEN FRAMES 80 & 81  
(BTM LONG #13 P - FRS 80/81)

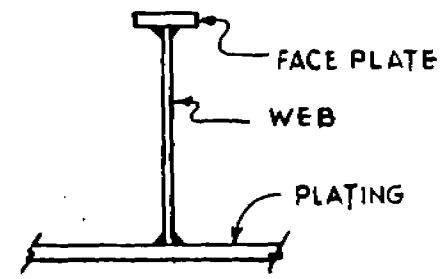
Quadrant C

NOTE: NUMBERING OF LONGITUDINALS VARY  
CLASS OF SHIPS THEREFORE MID-  
DRAWING SHOULD BE USED WITH



Quadrant D

THE TERMINOLOGY FOR THE COMPONENTS IN ANY BUILT-UP STRUCTURAL MEMBER IS:-



5 WITH EACH SECTION DRAWING.

291



**Chevron Shipping Company**

DRAWN: CWA  
DATE: 2-17-79

STANDARD STRUCTURAL NOMENCLATURE

S-50017-00

## Appendix E

### Sample Coding of Structural Members

If Test	Screen No.	Screen Prompt	Input
	1.	Tank No. ?	1P, 2C, 3S etc
	2.	Location in Tank ?	Fwd, Aft, Port, Stbd, Bottom, Overhead
If Fwd, Aft	3.	Stringer No. ?	0, 1, 2, 3, 4, 5 etc.
	4.	Height ?	Upper, Middle, Lower
	5.	Vertical Stiffener No.?	1, 2, 3, 4, 5 etc.
	6.	From Port or Stbd. ?	Port, Stbd
	7.	Structural Member ?	Stringer, Vertical Stiffener, Bracket, Ladder, Plating, Other
	8.	Defect Type ?	Corrosion, Buckling, Crack
If Crack	9.	Size ?	1, 2, 3, 4, etc. (cm)
If Corrosion or Buckling	9.	Size?	1, 2, 3, etc. (sq. meters)
If Corrosion	9A.	Piting?	Yes, No
If Piting	9B.	Size of Pits ?	1, 2, 3 etc (cm. diameter)
	9C.	Depth of Pits ?	1, 2, 3, 4, etc. (mm approx.)
	9D.	Percent Coverage ?	10, 20, 30 etc.
	10.	Repair	Vee & Weld
		Recommendation?	Crop & Renew, other, etc.

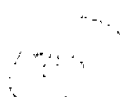
\*\* Return To Main Menu \*\*

<b>If Test</b>	<b>Screen No.</b>	<b>Screen Prompt</b>	<b>Input</b>
If Bottom or Overhead	3.	Frame # ? (From Fwd Bulkhead)	0,0 1,1 2,2 3,3 etc (If defect at frame)
			0,1 1,2 2, 3 (If defect between frames)
If Defect at Frame	4.	Height ?	Upper, Middle, Lower
	5.	Longitudinal # ?	0, 1, 2, 3, 4 etc.
	6.	From Port, Stbd, or C/L?	Port, Stbd, C/L
	7.	Structural Member ?	Face Plate, Web Plate, Vertical Stiffener, Lug, Bracket, Other
	8.	Defect Type ?	Corrosion, Buckling, Crack
	9.	Size ?	1, 2, 3, 4, etc. (cm)
	9.	Size?	1, 2, 3, etc. (sq. meters)
	9A.	Piting?	Yes, No
If Crack	9B.	Size of Pits ?	1, 2, 3 etc (cm. diameter)
	9C.	Depth of Pits ?	1, 2, 3, 4, etc. (mm approx.)
If Corrosion or Buckling	9D.	Percent Coverage ?	10, 20, 30 etc.
	10.	Repair Recommendation?	Vee & Weld Crop & Renew, other, etc.

\*\* Return To Main Menu \*\*

<b>If Test</b>	<b>Screen No.</b>	<b>Screen Prompt</b>	<b>Input</b>
If Between Frame	4.	Region ?	Fwd, Middle, Aft
	5.	Longitudinal # ?	0, 1, 2, 3, 4 etc.
	6.	From Port, Stbd, C/L?	Port, Stbd, C/L
	7.	Structural Member ?	Bottom Plating, Longitudinal Girder, Other
If Girder	8.	Structural Member ?	Web Plate, Face Plate Vertical Stiffener, Other Lower, Middle or Upper Long.
	9.	Defect Type ?	Corrosion, Buckling, Crack
If Crack	10.	Size ?	1, 2, 3, 4, etc. (cm)
If Corrosion or Buckling	10.	Size?	1, 2, 3, etc. (sq. meters)
If Corrosion	10A.	Piting?	Yes, No
If Piting	10B.	Size of Pits ?	1, 2, 3 etc (cm. diameter)
	10C.	Depth of Pits ?	1, 2, 3, 4, etc. (mm approx.)
	11.	Repair Recommendation ?	Vee and Weld Crop and Renew, other, etc

\*\* Return to Main Menu \*\*



<b>If Test</b>	<b>Screen No.</b>	<b>Screen Prompt</b>	<b>Input</b>
If Port Or Stbd.	3.	Frame # ? (From Fwd Bulkhead)	0,0 1,1 2,2 3,3 etc (If defect at frame) 0,1 1,2 2, 3 (If defect between frames)
If Defect at Frame	4.	Height, Long # ?	1, 2, 3, 4, etc.
	5.	Structural Member ?	Face Plate, Web Plate , Bracket Horizontal Stiffener, Lower or Upper Strut, Other
If Strut	6.	Structural Member ?	Face Plate, Web Plate, Bracket, Horizontal Stiffener, Other
	7.	Defect Type ?	Corrosion, Buckling, Crack
If Crack	8.	Size ?	1, 2, 3, 4, etc. (cm)
If Corrosion Buckling	8.	Size?	1, 2, 3, etc. (sq. meters)
If Corrosion	8A.	Piting?	Yes, No
If Piting (ter)	8B.	Size of Pits ?	1, 2, 3 etc (cm. diame-
	8C.	Depth of Pits ?	1, 2, 3, 4, etc. (mm approx.)
	9.	Repair Recommendation?	Vee & Weld Crop & Renew, other, etc.

\*\* Return To Main Menu \*\*

<b>If Test</b>	<b>Screen No.</b>	<b>Screen Prompt</b>	<b>Input</b>
If Defect Between Frame	4.	Height, Long. # ?	1, 2, 3, 4, 5, etc.
	5.	Structural Member ?	Side plating, Web Plate, Face Plate, Other
	6.	Defect Type ?	Corrosion, Buckling, Crack
If Crack	7.	Size ?	1, 2, 3, 4, etc. (cm)
If Corrosion or Buckling	7.	Size?	1, 2, 3, etc. (sq. meters)
	7A.	Piting?	Yes, No
If Piting	7B.	Size of Pits ?	1, 2, 3 etc (cm. diameter)
	7C.	Depth of Pits ?	1, 2, 3, 4, etc. (mm approx.)
	8.	Repair Recommendation ?	Vee and Weld Crop and Renew, other etc.

\*\* Return to Main Menu \*\*

# Appendix F

## Experimental Design Review

### I. Background

$\sigma^2$  - variance of population

$$= \sum_{i=1}^n (y_i - \bar{y})^2 / n$$

$\sigma$  - standard deviation

$\mu$  - population mean

$\bar{y}$  - sample mean

$$= \sum_{i=1}^n y_i / n$$

$s^2$  - unbiased estimator of  $\sigma^2$

$$= \sum_{i=1}^n (y_i - \bar{y})^2 / n - 1$$

$s$  - sample standard deviation

Empirical Rule : (assuming normal distribution)

$\mu \pm \sigma$  contains 68% of the measurements

$\mu \pm 2\sigma$  contains 95% of the measurements

$\mu \pm 3\sigma$  contains 99.7% of the measurements

### II. Student's t Confidence Interval

When sample size is small use Student's t for confidence intervals

$$\bar{y} \pm t_{\alpha/2} \frac{s}{\sqrt{n}}$$

$t_{\alpha/2}$  is the upper tail of the t distribution

area to the right of  $t_{\alpha/2}$  is  $\alpha/2$

$$P[t > t_{\alpha/2}] = \alpha/2$$



### III. Test of Hypothesis

Null Hypothesis :  $H_0 : \mu = (\#)$

Alternative Hypothesis :  $H_0 : \mu \neq (\#)$

Type I Error : reject null hypothesis when it is true (  $\alpha$  )

Type II Error : accept null hypothesis when it is false (  $\beta$  )

$$t = \frac{\bar{y} - \mu_0}{s / \sqrt{n}}$$

Test:

may be used as a test statistic to test the hypothesis :  
 $H_0 : \mu = \mu_0$

$|t| \geq t_{\text{table}}$  reject null hypothesis

### IV. Information in an Experiment

Noise - uncontrolled variables, obscures signal  
represented by  $\sigma^2$

Volume - strength of signal  
represented by n (# of experiments conducted)

Variance of y -  $V(y) = \sigma^2 / n$

Reduce Variance by decreasing  $\sigma^2$  or increasing n

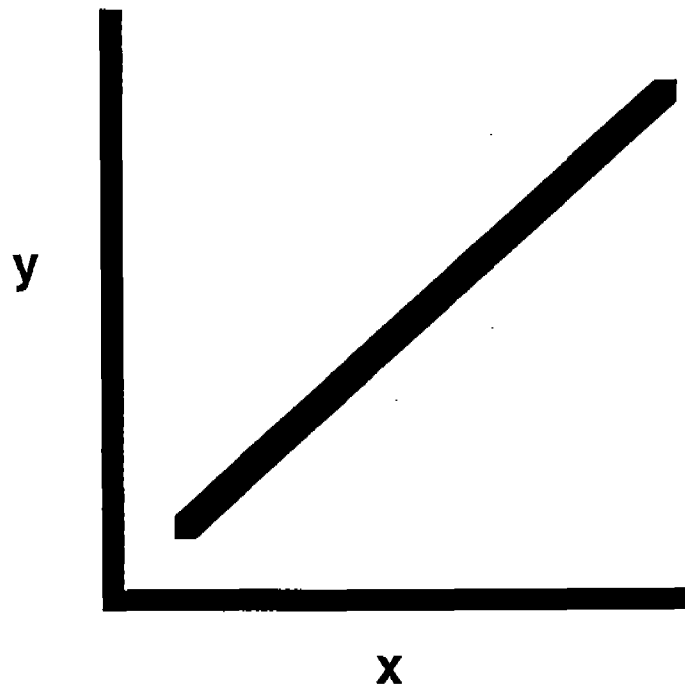
## V. Linear Statistical Models

Linear Model :  $y = \beta_0 + \beta_1 x + \varepsilon$  ( 2 dimensional)

$\varepsilon$  - random error

$$E(\varepsilon) = 0$$

$$V(\varepsilon) = \sigma^2$$



Linear Model (Multi Dimensional)

$$E(y) = \beta_0 + \beta_1 x_1 + \beta_2 x_2 + \beta_3 x_3 + \dots + \beta_k x_k$$

k+1 Dimensions

$x_1, x_2, x_3, \dots, x_k$  independent variables

Example : 2 diets A, B

compare the difference of the average weight gain  
between the two diets

$$y = \mu_A + \beta x + \varepsilon$$

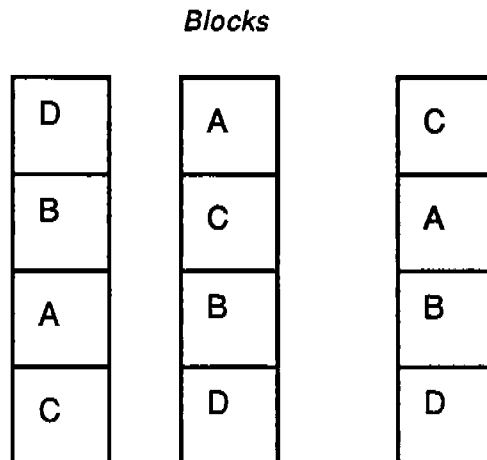
$$\beta = \mu_B - \mu_A$$

$x=1$  if subject fed diet B

$x=0$  if subject fed diet A

## VI. Noise Reducing Experimental Design

Randomized Block Design : Four Treatments A, B, C, D  
Three Blocks



$$E(y) = \beta_0 + \beta_1 x_1 + \beta_2 x_2 + \beta_3 x_3 + \beta_4 x_4 + \beta_5 x_5 + \varepsilon$$

Block  
Differences

Treatment  
Differences

$x_1 = 1$  if measurement made in block 2,  $x_1 = 0$  if not

$x_2 = 1$  if measurement made in block 3,  $x_2 = 0$  if not

$x_3 = 1$  if treatment B is applied,  $x_3 = 0$  if not

$x_4 = 1$  if treatment C is applied,  $x_4 = 0$  if not

$x_5 = 1$  if treatment D is applied,  $x_5 = 0$  if not

$\beta_0$  - average response for treatment A in block 1

$\beta_1$  - difference in the average response between block 2 and 1

$\beta_2$  - difference in the average response between block 3 and 1

$\beta_3$  - difference in the average response between treatment B

and A

$\beta_4$  - difference in the average response between treatment C

and A

$\beta_5$  - difference in the average response between treatment D

and A

This enables the experimenter to model each response, for example treatment B block 3 would be:  $y_{3B} = \beta_0 + \beta_2 + \beta_3 + \epsilon_{3B}$

In the above block design, 12 different equations could be formulated.

How the Randomized Block Design Reduces Noise :

If you subtract the average response between treatment B and treatment A and after some cancelation you are left

with

$\bar{y}_B - \bar{y}_A = \beta_3 + (\epsilon_B - \epsilon_A)$  where  $(\epsilon_B - \epsilon_A)$  is the error of estimation

or noise.

If the experiment had not been blocked you would have:

$\bar{y}_B - \bar{y}_A = \beta_3 + (\text{block effects do not cancel}) + (\epsilon_B - \epsilon_A)$  where  $(\text{block effects do not cancel}) + (\epsilon_B - \epsilon_A)$  is the error of estimation and hence excess noise.

The difference between the average response between treatment C and B is :  $\bar{y}_C - \bar{y}_B = (\beta_4 - \beta_3) + (\epsilon_C - \epsilon_B)$

Likewise if you compared the average response between blocks you would end up with :  $\bar{y}_3 - \bar{y}_1 = \beta_2 + (\epsilon_3 - \epsilon_1)$

## VII. Latin Square

The Latin Square allows you to block in two directions

<b>A</b>	<b>B</b>	<b>C</b>
<b>B</b>	<b>C</b>	<b>A</b>
<b>C</b>	<b>A</b>	<b>B</b>

$$y = \beta_0 + \beta_1 x_1 + \beta_2 x_2 + \beta_3 x_3 + \beta_4 x_4 + \beta_5 x_5 + \beta_6 x_6 + \varepsilon$$

$\beta_0$  - response for treatment A in row 1 column 1

$\beta_1$  - difference in the response between rows 2 and 1

$\beta_2$  - difference in the response between rows 3 and 1

$\beta_3$  - difference in the response between columns 2 and 1

$\beta_4$  - difference in the response between columns 3 and 1

$\beta_5$  - difference in the response between treatment B and A

$\beta_6$  - difference in the response between treatment C and A

$x_1, x_2, x_3, x_4, x_5, x_6$  are once again dummy variables and take values equal to 1 or 0 depending on where the observation was made. For example, the model for the observation in the second row, third column, would imply  $x_1=1, x_2=0, x_3=0, x_4=1, x_5=0,$  and  $x_6=0$ . Similarly a model could be written for all nine observations.

How the Latin square blocks in 2 directions:

$$\bar{y}_B = \frac{\sum_{i=1}^3 \sum_{j=1}^3 y_{ijB}}{3} = \beta_0 + \frac{\beta_1 + \beta_2}{3} + \frac{\beta_3 + \beta_4}{3} + \beta_5 + \bar{\epsilon}_B$$

Similarly for  $\bar{y}_A$ , and then after cancellation

$$\bar{y}_B - \bar{y}_A = \beta_5 + \bar{\epsilon}_B - \bar{\epsilon}_A \text{ where } \bar{\epsilon}_B - \bar{\epsilon}_A \text{ is the error of estimation}$$

If you only blocked in one direction namely rows:

$$\bar{y}_B - \bar{y}_A = \beta_5 + (\text{column effects}) + \bar{\epsilon}_B - \bar{\epsilon}_A$$

Since it is possible for one or more of the columns to contain two or more experimental units receiving the same treatment.

Latin square is also able to tell if there is a difference between rows and columns.

Degrees of freedom available for estimating  $\sigma^2$  for the Latin Square Design:

The number of degrees of freedom for estimating  $\sigma^2$  is equal to  $n$ , the number of observations in the experiment, less one degree of freedom for each parameter in the model or for the Latin square:

$$\text{d.f.} = p^2 - [1 + 3(p-1)] = p^2 - 3p + 2 = (p-1)(p-2)$$

For the 3X3 Latin Square d.f. = (2)(1) = 2 as compared to 4 without the Latin square design. Looking at the t values for these degrees of freedom suggests that a sizable reduction in noise would have to be obtained in order to compensate for the loss in degrees of freedom and still provide an increase in the amount of information in the experiment. For a 4X4 Latin square the increase in tabulated t value is not too serious as one moves from 9 to 6 degrees of freedom for estimating  $\sigma^2$  indicating that the loss of information due to the

increase in the number of parameters in the model is slight. Hence it pays the experimenter to employ the Latin Square design if he suspects a possible trend in two directions.

### VIII. Fitting the General Linear Model

Estimation of unknown  $\beta$ 's by method of least squares.

$y = \beta_0 + \beta_1 x + \varepsilon$  where the expected value of  $y$  is the equation of a straight line  $E(y) = \beta_0 + \beta_1 x$ . The prediction equation will be indicated as  $\hat{y} = \hat{\beta}_0 + \hat{\beta}_1 x$  and

$$SSE = \sum_{i=1}^n (y_i - \hat{y}_i)^2 = \sum_{i=1}^n [y_i - (\hat{\beta}_0 + \hat{\beta}_1 x_i)]^2$$

To minimize you take  $\frac{\partial SSE}{\partial \hat{\beta}_0}$  and  $\frac{\partial SSE}{\partial \hat{\beta}_1}$  and set equal to 0, then solve the two equations simultaneously. You would do the same for multiple parameters and have  $K+1$  simultaneous equations, which can be written in matrix form.

To solve by matrix algebra

$$\begin{bmatrix} A \end{bmatrix} \begin{bmatrix} V \end{bmatrix} = \begin{bmatrix} G \end{bmatrix}$$

OR  $V = A^{-1}G$

So for our model  $K+1$  equations for the model

$y = \beta_0 x_0 + \beta_1 x_1 + \beta_2 x_2 + \dots + \beta_k x_k + \varepsilon$  where  $x_0$  is a dummy variable and always equal to 1.

With n experiments then:

$$Y = \begin{bmatrix} Y_1 \\ Y_2 \\ \vdots \\ Y_n \end{bmatrix} \quad X = \begin{bmatrix} 1 & X_{11} & \dots & X_{k1} \\ \vdots & \vdots & \vdots & \vdots \\ \vdots & \vdots & \vdots & \vdots \\ 1 & X_{1n} & \dots & X_{kn} \end{bmatrix}$$

where the Y's are the experimental results.

$$\hat{\beta} = \begin{bmatrix} \hat{\beta}_0 \\ \hat{\beta}_1 \\ \vdots \\ \hat{\beta}_k \end{bmatrix}$$

then it can be shown that

$$* * * \quad \hat{\beta} = (X'X)^{-1} X'Y \quad * * *$$



**IX. Inference Making ( Confidence Intervals and Testing Hypothesis)**

Assume  $\epsilon_1, \epsilon_2, \dots, \epsilon_n$  are mutually independent, the expected value is 0 and the variance is equal to  $\sigma^2$ , it can be shown that  $v(\hat{\beta}_i) = C_i \sigma^2$  where  $C_i$ ,  $C_i$  is from the  $(X'X)^{-1}$  matrix. Then using the empirical rule  $\pm 2\sigma_{\hat{\beta}_i} = 2\sigma\sqrt{C_i}$  then the probability the error of estimation is less than  $2\sigma\sqrt{C_i}$  will be approximately equal to .95.

Estimating  $\sigma^2$

$s^2 = \frac{SSE}{n - (k + 1)}$  is an unbiased estimator of  $\sigma^2$ . and it can be shown that

$$SSE = Y'Y - \hat{\beta}'X'Y$$

Test of Hypothesis Concerning  $\beta_i$

$H_0: \beta_i = 0$  and  $t = \frac{\hat{\beta}_i - \beta_i}{s\sqrt{C_i}}$  can be shown to possess a Student's t distribution

and the previously mentioned t test can be used. If the hypothesis cannot be rejected then a type II error must be pursued. The confidence interval may be too large, in which case may need to be collected.

↑  
additional data

Confidence Interval for  $\beta_i$



It can be shown that a  $(1 - \alpha)$  confidence interval for  $\beta_i$  is :

$$\hat{\beta}_i \pm t_{\alpha/2} s \sqrt{c_i}$$

### X. Multiparameter Hypothesis : The Analysis of Variance

If you do  $K$  independent  $t$  tests for each parameter each with  $\alpha$ , the probability of falsely rejecting at least one of the  $k$  null hypothesis, assuming all are true, is  $\{1 - (1 - \alpha)^k\}$ . If  $k$  becomes large the probability becomes uncomfortably large.

A number of statistical techniques are available for protecting against making type I errors in repeated  $t$  tests. The analysis of variance is one such technique.

Let Model 1:  $y = \beta_0 + \beta_1 x_1 + \beta_2 x_2 + \dots + \beta_g x_g + \varepsilon$  where  $g < k$  (reduced model)

Model 2:  $y = \beta_0 + \beta_1 x_1 + \dots + \beta_g x_g + \beta_{g+1} x_{g+1} + \dots + \beta_k x_k + \varepsilon$  (complete model)

If any of the terms past  $g$  are important information contributing variables then Model 2 should predict with a smaller error of prediction than Model 1 and hence  $SSE_2 < SSE_1$

The greater the difference ( $SSE_1 - SSE_2$ ) the stronger the evidence to reject the null hypothesis that  $H_0: \beta_{g+1} = \beta_{g+2} = \dots = \beta_k = 0$

How large is large? One can use the  $F$ -statistic test where

$$F = \frac{s_3^2}{s_2^2} \text{ and } s_2^2 = \frac{SSE_2}{n - (k + 1)}, \quad s_3^2 = \frac{(SSE_1 - SSE_2)}{k - g}$$

If F calculated is greater than F tabulated then it falls in the rejection region. If there is rejection then individual comparison can be made as discussed previously.

For the randomized block design you could test there is no difference between blocks or  $H_0: \beta_1 = \beta_2 = 0$  and model 1 or the reduced model you would eliminate  $x_1$  and  $x_2$

### The Analysis of Variance for the Latin Square

$$\text{Sum of Squares for Treatments : } SST = \frac{\sum_{i=1}^p T_i^2}{b} - CM$$

$$\text{Sum of Squares for Rows : } SSR = \frac{\sum_{i=1}^p R_i^2}{p} - CM$$

$$\text{Sum of Squares for Columns : } SSC = \frac{\sum_{i=1}^p C_i^2}{p} - CM$$

$T_i$  - total of the p observations receiving treatment i

$R_i$  - total of the p observations in row i

$C_i$  - total of the p observations in column i

p - number of treatments

CM - correction for the mean

$$= \frac{\left( \sum_{i=1}^n y_i \right)^2}{n} \quad \text{where } n = p^2$$

$$\text{The Sum of Squares for Blocks : } SSB = \frac{\sum_{i=1}^b B_i^2}{p} - CM$$

Mean Squares :  $MST = SST / p-1$



$$\begin{aligned} \text{MSR} &= \text{SSR} / p-1 \\ \text{MSC} &= \text{SSC} / p-1 \end{aligned}$$

Another identity that can be used for Sum of Squares for Error:

$$\text{SSE} = \sum_{i=1}^{p^2} (y_i - \bar{y})^2 - \text{SSR} - \text{SSC} - \text{SST}$$

where Total 
$$\text{SS} = \sum_{i=1}^{p^2} (y_i - \bar{y})^2 = \sum_{i=1}^{p^2} y_i^2 - \text{CM}$$

**XI. ANOVA table for a p x p Latin Square Design**

<u>source</u>	<u>d.f.</u>	<u>SS</u>	<u>MS</u>	<u>F</u>
Rows	p-1	SSR	MSR	MSR / s <sup>2</sup>
Columns	p-1	SSC	MSC	MSC / s <sup>2</sup>
Treatments	p-1	SST	MST	MST / s <sup>2</sup>
Error	p <sup>2</sup> - 3p + 2	SSE	s <sup>2</sup>	

## Appendix G

### List of Companies Mentioned In Report

1. Chevron Shipping Co.  
555 Market St., San Francisco CA 94105
2. American Bureau of Shipping  
45 Eisenhowr Dr., Paramus NJ 07653
3. Eveready Battery Co.  
Checkerboard Sq., St. Louis MO 63164
4. Pelican Products Inc.  
2255 Jefferson St., Torrance CA 90501
5. Oreck Corporation  
100 Plantation Rd., New Orleans LA 70123
6. Exxon Shipping Company  
P.O. Box 2189, Houston TX 77001
7. Spider Staging Corporation  
13536 Beacon Coal Mine Rd., Seattle WA 98178
8. Stageaway Vessel Support Services  
208 S.E. 105th Ave., Vancouver WA 98664
9. Shell International Marine Ltd of London
10. S&H Diving Corporation  
P.O. Boxd 4428, Houston TX 77210
11. Mobil Shipping and Transportation Co.  
3225 Gallows Rd., Fairfax VA 22037
12. Spectrum Engineering Inc.  
5825 Oberlin Dr. Suite 100, San Diego CA 92121

13. Vocollect Inc.  
664 Linden Ave., East Pittsburgh PA 15112
14. Hafa International Inc.  
7545 Central Industrial Blvd., Riviera Beach FL 33404
15. Shell International Marine Ltd. of London  
MRT/4 Centre, London SE1 7NA.
16. Scott Aviation  
225 Erie St., Lancaster NY 14086