

SSC-452

**ALUMINUM STRUCTURE DESIGN
AND FABRICATION GUIDE**



This document has been approved
For public release and sale; its
Distribution is unlimited

SHIP STRUCTURE COMMITTEE
2007

Appendix A

Design Studies

Study 1	Comparative Design of a 61-meter, 50-knot High Speed Craft Page A-2
Study 2	Redesign of an Aluminum High-Speed Ferry in Steel Page A-11
Study 3	Comparative Design of a 42.67 meter High-Speed Craft Page A-23
Study 4	Redesign of the Steel Deckhouse of a Destroyer in Aluminum Page A-39

Design Study 1

Comparative Design of a 61-meter, 50-knot High Speed Craft

References:

- A. Stone, Kevin F., “Comparative Structural Requirements for High Speed Craft”, Ship Structure Committee Report SSC-439, U.S. Coast Guard Ship Structure Committee, Washington D.C., February 2005
- B. Stone, Kevin F. and Derek S. Novak, “Comparative Structural Requirements for High Speed Craft,” Transactions of the Society of Naval Architects and Marine Engineers, 2006.

The following comparative analysis will be an extension of the comparative design study of the Ship Structure Committee report, Reference A. That report had errors, which were corrected by Reference B. The original study dealt with only the aluminum bottom and side structure. Requirements for hull girder section modulus midships, and plate thickness, stiffener and transverse frame section modulus at the LCG, and several other points along the hull were given. In this comparative study, those requirements will be extended to provide the same requirements in steel structure, and structural members will be selected to make a comparison of the weight of bottom and side panels. Because sufficient information was not provided in the original study, deck scantlings will not be determined nor will hull girder section modulus to determine if local requirements or hull girder requirements determine the actual section modulus.

The original study was performed assuming 5083-H116 plating and 6061-T6 extrusions, with welded yield strengths of 165 MPa and 138 MPa, respectively. The same aluminum will be used in this analysis; the steel will be HS-36, with a yield strength of 355 MPa. For a ship of this length, composite construction is possible, but sufficiently unusual that should such a vessel be designed and constructed, there would probably be unusual structural features or special materials used, so a GRP alternative will not be considered in this study. The calculations were performed in accordance with the ABS HSC guide,

Principal Dimensions

$$L_{WL} = 61 \text{ meters}$$

$$V = 50 \text{ knots}$$

$$H_{1/3} = L/12 = 5.08 \text{ m}$$

$$\Delta = 950 \text{ tonnes}$$

$$\beta_{LCG} \text{ (deadrise angle)} = 17^\circ$$

$$B = 12.9 \text{ m}$$

$$B_{WL} = 11.7 \text{ m}$$

$$C_B = 0.451$$

$$\tau \text{ (trim angle at speed)} = 3^\circ$$

The acceleration, η_{CG} , at the LCG is given by the formula:

$$\eta_{CG} = N_2 [(12 h_{1/3} / B_{WL}) + 1.0] \tau (50 - \beta_{CG}) [V^2 (B_{WL})^2 / \Delta]$$

where:

$$N_2 = 0.0078$$

Δ = displacement (in kilograms)

$$\eta_{CG} = 1.73$$

This computation for the acceleration is extremely sensitive to the trim angle, which is a small number. If the trim angle were to increase by one degree, the acceleration would be 33 percent greater. The errors in the original SSC study apparently stemmed from the interpretation of trim angle, which affects the design slam pressures and required hull girder section modulus.

Hull Girder Section Modulus

The required section modulus is given by the equation:

$$SM_R = C_1 C_2 L^2 B(C_B + 0.7) K_3 K_4 C Q \text{ cm}^2 \text{ m}$$

$$C_1 = 0.0451 L + 3.65 = 6.4011 \text{ (} L \geq 61 \text{ meters)}$$

$$C_2 = 0.01 \text{ (SI units)}$$

$$K_3 = 0.70 + 0.30 [(V/\sqrt{L} + 1.2) / 3.64] = 1.326$$

$$K_4 = 1.0 \text{ for unrestricted ocean service}$$

$$C = 1.0 \text{ for steel, } 0.90 \text{ for aluminum, and } 0.80 \text{ for FRP.}$$

$$Q = 0.72 \text{ for HS 36 steel}$$

For aluminum, $Q_{\min} = 635 / (\sigma_y + \sigma_u)$, where σ_y and σ_u are the welded yield and ultimate strength.

$$\text{Or } Q = 0.9 + q_5, \text{ where } q_5 = 115 / \sigma_y$$

$$\text{For 5083-H116 aluminum, } Q = 1.597$$

$$\text{For GRP, } Q = 400 / \sigma_U = 400 / 207 = 1.932.$$

$$S_{MR} \text{ (steel)} = 3,813 \text{ cm}^2 \text{ m}$$

$$S_{MR} \text{ (aluminum)} = 7,613 \text{ cm}^2 \text{ m}$$

For planning and semi-planing craft with speed greater than 25 knots, the following requirements for section modulus apply:

$$SM = \Delta L_W / C_2 (128 Y_F - 178 Y_{CG} - 50) C Q$$

or

$$SM = \Delta L_W / C_2 (78 Y_{CG} - 128 Y_A - 50) C Q$$

where:

Δ = displacement in tones

$$Y_F = 1.2 \quad \eta_{CG} = 1.2 * 1.73 = 2.076$$

$$Y_{CG} = 0.6 \quad \eta_{CG} = 0.6 (1.73) = 1.038$$

$$Y_A = 0.0$$

$$C_2 = 1,320$$

$$C_{\text{(steel)}} = 1.0$$

$$C_{\text{(aluminum)}} = 0.90$$

$$Q_{\text{(HS-36 steel)}} = 0.72$$

$$Q_{\text{(5083 aluminum)}} = 1.597$$

The resulting section modulus requirements are:

$$S_{MR} \text{ (steel)} = 978 \text{ cm}^2 \text{ m}$$

$$979 \text{ cm}^2 \text{ m}$$

$$S_{MR} (\text{aluminum}) = \begin{array}{l} 1,934 \text{ cm}^2 \text{ m} \\ 1,954 \text{ cm}^2 \text{ m} \end{array}$$

The section modulus is also to be determined using a hull girder bending moment calculation for ships with length greater than or equal to 61 meters. The sag and hog wave moments are:

$$M_{WS} = -k_1 C_1 L^2 B (C_B + 0.7) \times 10^{-3} = -43,940 \text{ ton-meters} (k_1 = 110)$$

$$M_{WH} = +k_2 C_1 L^2 B C_B \times 10^{-3} = +32,580 \text{ ton-meters} (k_2 = 190)$$

From the original studies, the still water moment is approximately $-6,000$ ton-meters, so the total moments are:

$$M_{TS} = -50,923 \text{ ton-meters}$$

$$M_{TH} = +28,028 \text{ ton-meters}$$

The required section modulus is given by:

$$SM = M_T K_3 C Q / fp$$

where K_3 , C , and Q are as before, and $fp = 17.5$

$$S_{MR} (\text{steel}) = 2,780 \text{ cm}^2 \text{ m}$$

$$S_{MR} (\text{aluminum}) = 5,550 \text{ cm}^2 \text{ m}$$

Considering all three requirements, the required section moduli are:

$$S_{MR} (\text{steel}) = 3,813 \text{ cm}^2 \text{ m}$$

$$S_{MR} (\text{aluminum}) = 7,613 \text{ cm}^2 \text{ m}$$

Bottom Structure

The design slam pressure varies along the length. For this study, the value of the bottom slam pressure at the longitudinal center of gravity, p_{bCG} , is used at midships.

$$p_{bCG} = (N_1 \Delta / L_W B_W) (1 + \eta_{CG}) F_D$$

Where:

$$N_1 = 0.1$$

F_D is a factor determined from a graph relating the ratio of the design area, A_D , to a reference area, A_R .

$$p_{bCG} = 363.2 F_D$$

s = spacing of longitudinals or stiffeners, cm, = 26 cm

l = length of unsupported span of internals,

$$l_{st} = 80 \text{ cm, stiffeners}$$

$$l_{tr} = 182 \text{ cm, transverses (assume 7s)}$$

$$A_R = \text{reference area, cm}^2 = 6.95 \Delta / d \text{ cm}^2 = 2.0 \times 10^6 \text{ cm}^2$$

The resulting design pressures are:

Plating: 363.2 kn/m^2

Stiffeners: 363.2 kn/m^2

Transverses: 345.0 kn/m^2

Plating

$$t = s \sqrt{(p k / 1000 \sigma_a)}$$

$$\sigma_a = 0.90 \sigma_y = 320 \text{ MPa for steel, } 148 \text{ MPa for aluminum}$$

$$k = \text{aspect ratio factor} = 0.5 \text{ for } l/s \geq 2.0$$

$$t_{(HS-36)} = 6.2 \text{ mm}$$

$$t_{(5083)} = 9.1 \text{ mm}$$

Minimum thickness

$$\text{Steel: } t_s \geq 0.44 \sqrt{(KL)} + 2.0 \text{ mm}$$

where:

$$K = (\eta_y/y)^e$$

$$\eta_y = 235 \text{ MPa}$$

$$y = \sigma_y = 355 \text{ MPa}$$

$$0.7 \sigma_{TS} = 0.7 \times 490 = 343 \text{ MPa}$$

$$e = 0.75 (y > 235)$$

$$t_s \geq 0.44 \sqrt{(0.75 \times 61)} + 2.0 \text{ mm} = 5.0 \text{ mm}$$

Aluminum

$$t_{al} \geq 0.7 \sqrt{L} + 1.0 = 0.7 \sqrt{(61)} + 1.0 = 6.47 \text{ mm}$$

The minimum thicknesses do not govern bottom plating, which remains:

$$t_{(HS-36)} = 6.2 \text{ mm}$$

$$t_{(5083)} = 9.1 \text{ mm}$$

Stiffeners

$$SM_R = 83.3 p s l^2 / \sigma_a$$

where

$$\sigma_a (\text{slam}) = 0.55 \sigma_y = 195 \text{ MPa for steel}$$

$$= 75.9 \text{ MPa for aluminum}$$

$$I_R = 260 p s l^3 / K_4 E$$

where:

$$K_4 = 0.0015 \text{ for steel, } 0.0021 \text{ for aluminum}$$

$$E = 207 \times 10^3 \text{ MPa for steel, } 71 \times 10^3 \text{ MPa for aluminum}$$

$$\text{Effective plate} = l/3 = 80/3 = 26.7 \text{ cm}$$

$$80 t (\text{steel}) = 80 \times 0.62 = 49.6 \text{ cm}$$

$$60 t (\text{aluminum}) = 60 \times 0.91 = 54.6 \text{ cm}$$

$$s = 26 \text{ cm}$$

$$\text{Effective plate (steel and aluminum)} = 26 \text{ cm}$$

	SM_R (cm ³)	I_R = (cm ⁴)	Section selected
HS-36 steel	21.9	31.1	90 x 9.1 mm FB
6061-T6 aluminum	66.3	64.8	120 x 50 x 3.00 kg/m bulb tee

Transverse frames

Assume that both steel and aluminum will be built-up sections, using HS-36 steel and 5083-H116 aluminum.

$$SM_R = 83.3 p s l^2 / \sigma_a$$

$$I_R = 260 p s l^3 / K_4 E$$

Where:

$$\sigma_a \text{ (slam)} = 0.80 \sigma_y = 284 \text{ MPa for steel}$$

$$= 110 \text{ MPa for aluminum}$$

$$K_4 = 0.0015 \text{ for steel, } 0.0021 \text{ for aluminum}$$

$$\text{Effective plate} = l/3 = 1,820 / 3 = 607 \text{ mm}$$

Minimum web d/t

$$\text{(steel) } d/t \geq 70 \sqrt{(235/\sigma_y)} = 70 \sqrt{(235 / 355)} = 60$$

$$\text{(aluminum) } d/t \geq 50 \sqrt{(127.6/\sigma_y)} = 50 \sqrt{(127.6 / 165)} = 39$$

Minimum flange b/t

$$\text{(steel) } b/t \geq 12 \sqrt{(235/\sigma_y)} = 12 \sqrt{(235 / 355)} = 10$$

$$\text{(aluminum) } b/t \geq 9 \sqrt{(127.6/\sigma_y)} = 9 \sqrt{(127.6 / 165)} = 7$$

	SM_R (cm ³)	I_R = (cm ⁴)	Section selected
HS-36 steel	268	1,393	200 x 5 / 100 x 12 T
5083-H116 aluminum	692	2,900	300 x 8 / 100 x 14 T

Side Structure

s = spacing of longitudinals or stiffeners, cm, = 40 cm

l = length of unsupported span of internals,

$$l_{st} = 80 \text{ cm, stiffeners}$$

$$l_{tr} = 242.4 \text{ cm, transverses}$$

At the longitudinal center of gravity, the slope of the side exceeds 70 degrees, so slam pressures do not apply, only hydrostatic pressures.

$$p_s = N_3 (F_s H + d - y) \text{ kN/m}^2$$

where:

$$N_3 = 9.8$$

$$F_s = 1.0 \text{ for unrestricted service, table 3/8.1}$$

$$p_s =$$

$$= 0.05 N_3 L \text{ kN/m}^2 \text{ at or below } L / 15 \text{ above BL or at any height forward of } 0.125L \text{ from the stem}$$

$$\begin{aligned}
&= 29.89 \text{ kN/m}^2 \text{ at or below 4.07 m above BL or at any height forward of} \\
&\quad 0.51 \text{ m from the stem} \\
&= 0.033N_3L \text{ kN/m}^2 \text{ above } L/15 \text{ above BL and aft of } 0.125L \text{ from the stem} \\
&= 19.73 \text{ kN/m}^2 \text{ above 4.07 m above BL and aft of 0.51 m from the stem}
\end{aligned}$$

Accordingly, at the LCG,
 $p_s = 19.73 \text{ kN/m}^2$

This hydrostatic pressure is independent of applied area, and is used for the design of all side structure.

Plating

$$\begin{aligned}
t &= s \sqrt{(p k / 1000 \sigma_a)} \\
\sigma_a &= 0.40 \sigma_y = \\
&\quad = 142 \text{ MPa for steel,} \\
&\quad = 66 \text{ MPa for aluminum} \\
k &= \text{aspect ratio factor} = 0.5 \text{ for } l/s \geq 2.0
\end{aligned}$$

$$\begin{aligned}
t_{(HS-36)} &= 3.3 \text{ mm} \\
t_{(5083)} &= 4.87 \text{ mm}
\end{aligned}$$

Minimum thickness

$$\text{Steel: } t_s \geq 0.40 \sqrt{(KL)} + 2.0 \text{ mm}$$

where:

$$\begin{aligned}
K &= (\eta_y/y)^e \\
\eta_y &= 235 \text{ MPa} \\
y &= \sigma_y = 355 \text{ MPa} \\
&\quad 0.7 \sigma_{TS} = 0.7 \times 490 = 343 \text{ MPa} \\
e &= 0.75 (y > 235)
\end{aligned}$$

$$t_s \geq 0.40 \sqrt{(0.75 \times 61)} + 2.0 \text{ mm} = 4.7 \text{ mm}$$

Aluminum

$$t_{al} \geq 0.62 \sqrt{L} + 1.0 = 0.62 \sqrt{(61)} + 1.0 = 5.84 \text{ mm}$$

The minimum thicknesses now govern side plating, which are:

$$\begin{aligned}
t_{(HS-36)} &= 4.7 \text{ mm} \\
t_{(5083)} &= 5.84 \text{ mm}
\end{aligned}$$

(Note: both (Stone, 2005) and (Stone and Novak ,2006) erroneously applied the minimum bottom plate thickness of 6.47 mm to the aluminum side plating.)

Stiffeners

$$\begin{aligned}
SM_R &= 83.3 p s l^2 / \sigma_a \\
&\text{where}
\end{aligned}$$

$$\begin{aligned}
\sigma_a \text{ (slam)} &= 0.50 \sigma_y = 177 \text{ MPa for steel} \\
&= 69 \text{ MPa for aluminum}
\end{aligned}$$

$$I_R = 260 \text{ psi}^3 / K_4 E$$

where:

$$K_4 = 0.0015 \text{ for steel, } 0.0021 \text{ for aluminum}$$

$$E = 207 \times 10^3 \text{ MPa for steel, } 71 \times 10^3 \text{ MPa for aluminum}$$

$$\text{Effective plate} = \quad 1/3 = 80 / 3 = 26.7 \text{ cm}$$

$$80 \text{ t (steel)} = 80 \times 0.47 = 36.7 \text{ cm}$$

$$60 \text{ t (aluminum)} = 60 \times 0.58 = 34.8 \text{ cm}$$

$$s = 40 \text{ cm}$$

$$\text{Effective plate (steel)} = 26.7 \text{ cm}$$

$$\text{(aluminum)} = 26.7 \text{ cm}$$

	$SM_R \text{ (cm}^3\text{)}$	$I_R \text{ (cm}^4\text{)}$	Section selected
HS-36 steel	2.4	3.4	50 x 5 mm FB
6061-T6 aluminum	6.1	7.0	76.2 x 221 x 1.397 kg/m bulb tee

Transverse frames

Assume that both steel and aluminum will be built-up sections, using HS-36 steel and 5083-H116 aluminum.

$$SM_R = 83.3 \text{ p s } l^2 / \sigma_a$$

$$I_R = 260 \text{ psi}^3 / K_4 E$$

Where:

$$\sigma_a \text{ (hydro)} = 0.50 \sigma_y = 177 \text{ MPa for steel}$$

$$= 82.5 \text{ MPa for aluminum}$$

$$K_4 = 0.0015 \text{ for steel, } 0.0021 \text{ for aluminum}$$

$$\text{Effective plate} = 1/3 = 2,424 / 3 = 808 \text{ mm}$$

Use minimum effective plate = 7450 mm for frames and deep members.

Minimum web d/t

$$\text{(steel)} \quad d/t \geq 70 \sqrt{(235/\sigma_y)} = 70 \sqrt{(235 / 355)} = 60$$

$$\text{(aluminum)} \quad d/t \geq 50 \sqrt{(127.6/\sigma_y)} = 50 \sqrt{(127.6 / 165)} = 39$$

Minimum flange b/t

$$\text{(steel)} \quad b/t \geq 12 \sqrt{(235/\sigma_y)} = 12 \sqrt{(235 / 355)} = 10$$

$$\text{(aluminum)} \quad b/t \geq 9 \sqrt{(127.6/\sigma_y)} = 9 \sqrt{(127.6 / 165)} = 7$$

	$SM_R \text{ (cm}^3\text{)}$	$I_R \text{ (cm}^4\text{)}$	Section selected
HS-36 steel	44	188	80 x 5 / 80 x 6 T
5083-H116 aluminum	94	391	100 x 5 / 100 x 8 T

SUMMARY OF STRUCTURE

Steel

Bottom

Plate: 6.2 mm
 Stiffeners: 90 x 9.1 FB
 Transverses 200 x 5 / 100 x 12 T

Side

Plate: 4.7 mm
 Stiffeners: 50 x 5 FB
 Transverses 80 x 5 / 80 x 6 T

Aluminum

Bottom

Plate: 9.1 mm
 Stiffeners: 120 x 50 x 3.00 kg/m Rounded Tee
 Transverses 300 x 8 / 100 x 15 T

Side

Plate: 5.8 mm
 Stiffeners: 76.2 x 21 x 1.397 kg/m bulb flat
 Transverses 100 x 5 / 100 x 8 T

Weight of Structure

Steel

Bottom

Plate 80 cm x 182 cm x 0.62 cm x $7.842 \times 10^{-3} \text{ kg/cm}^3$	= 70.79 kg
Stiffeners (6) 80 cm x 9 cm x 0.91 cm x $7.842 \times 10^{-3} \text{ kg/cm}^3$	= 30.83
Transverse web 182 cm x 20 cm x 0.5 cm x $7.842 \times 10^{-3} \text{ kg/cm}^3$	= 14.27
flange 182 cm x 10 cm x 1.2 cm x $7.842 \times 10^{-3} \text{ kg/cm}^3$	= <u>17.13</u>

Total bottom panel 133.02 kg

Side

Plate: 242.4 cm x 80 cm x 0.47 cm x $7.842 \times 10^{-3} \text{ kg/cm}^3$	= 71.47 kg
Stiffeners (5) 80 cm x 5.0 cm x 0.5 cm x $7.842 \times 10^{-3} \text{ kg/cm}^3$	= 7.84
Transverse web 242.4 cm = 8 cm x 0.5 cm x $7.842 \times 10^{-3} \text{ kg/cm}^3$	= 7.60
Flange 242.4 cm x 8 cm x 0.6 cm x $7.842 \times 10^{-3} \text{ kg/cm}^3$	= <u>9.12</u>

Total side Panel 96.03 kg

Total steel bottom and side = 133.02 + 96.03 = 229.05 kg

Aluminum

Bottom

Plate: 80 cm x 182 cm x 0.91 cm x 2.66×10^{-3} kg/cm ³	= 35.24 kg
Stiffeners (6) x 8 m x 3.00 kg m	= 14.40
Transverse web 182 cm x 30 cm x 0.8 cm x 2.66×10^{-3} kg/cm ³	= 11.62
Flange 182 cm x 10 cm x 1.4 cm x 2.66×10^{-3} kg/cm ³	= <u>6.78</u>

Total bottom panel 68.04 kg

Side

Plate 242.4 cm x 80 cm x 0.58 cm x 2.66×10^{-3} kg/cm ³	= 29.92 kg
Stiffeners (5) 0.8 m x 1.397 kg/m	= 5.59
Transverse web 242.4 cm x 10 cm x 0.8 cm x 2.66×10^{-3} kg/cm ³	= 3.22
Flange 242.4 cm x 10 cm x 0.8 cm x 2.66×10^{-3} kg/cm ³	= <u>5.16</u>

Total side panel 43.89

Total Aluminum bottom and side = 68.04 + 43.89 = 111.93 kg

Weight of aluminum / weight of steel = 111.93 / 229.05 = 0.489

Design Study 2

Redesign of an Aluminum High-Speed Ferry in Steel

References:

- A. Kramer, Raymond H., C. McKesson, J. McConnell, W. Cowardin, and B. Samuelsen. Structural Optimization For Conversion of Aluminum Car Ferry to Support Military Vehicle Payload, Ship Structure Committee report SSC-438, 2005.
- B. Kramer, Raymond H., US Navy High Speed Craft – Comparison of ABS and DNV Structural Requirements, Transactions of the Society of Naval Architects and Marine Engineers, Vol. 113, 2005.

A 96-meter high-speed catamaran ferry was selected for comparative design study 2 because Kramer et al. had made an analysis of the original design in References A and B. As those documents were reviewed in greater detail, it was discovered that the analysis had been limited to the lower hull areas that are subject to slam pressures and to the cargo deck. Because of that limitation in the analysis of the original design and because further details of the remainder of the original structure were not readily available, only those areas, originally constructed in aluminum, were redesigned in steel. Kramer et al. analyzed the cargo deck using the finite element method. but performing such analysis for the steel variant would significantly increase the scope of this study, and was not done. The transverse structure was not evaluated because it was not done in the Kramer et al. studies. The redesign therefore was limited to plating panels on the bottom shell, side shell, and wet deck midships.

The vessel was constructed for restricted service in accordance with DNV +1A1 HSLC R4 (enclosed waters 20,20). The SSC study, SSC 438, Structural Optimization for Conversion of Aluminum Car Ferry to Support Military Vehicle Payload, redesigned the vessel to carry a military payload and for unrestricted service. As was noted in the 2005 SNAME Paper (Kramer, 2005) this vessel is actually unsuited for unrestricted service because of the low clearance (1.7 m) between the wet deck and the water. The classification implies that the ship will operate on seas with a significant wave height greater than 2.5 meters.

The vessel was redesigned in steel to DNV Class R4, the same DnV classification as the original design. The vessel was built with 5083-H116 plate and 6061-T6 extrusions. The redesign is in VN-36 steel, which has a 355 MPa (51 ksi) yield strength.

PACIFICAT CLASS - VESSEL SPECIFICATION

“PacifiCat Explorer”, “PacifiCat Discovery”, “HSF 003”

122 Meter High-Speed Passenger / Vehicle Ferries (minor differences in outfit occur between ships)

General Specifications

Builder: Catamaran Ferries International Inc.

Year Completed: “Explorer” – June 1999, “Discovery” – December 1999, “Voyager” – completed and mothballed August 2000

Owner: British Columbia Ferry Corporation.

Designer: INCAT Designs Sydney, Australia in collaboration with Robert Allan Ltd. of Vancouver, British Columbia

Length Overall: 122.50 m

Length Waterline: 96.00m

Beam: 25.80m

Beam of Hulls: 6.00m

Draft: 3.76m (approx.) in salt water

$C_B = \Delta / (1.025 L B_{WL} T) = 1,882 / (1.025 \times 96 \times (2 \times 6) \times 3.76) = 0.403$

Certification: Transport Canada Marine Safety, in accordance with 1994 IMO International Code of Safety for High Speed Craft (HSC), July

1993 (MSC 63/23 Addendum 2, HSC) for voyages in Canadian Home Trade III waters

DNV +1A1 HSLCR4 (enclosed waters 20,20) (Can) Car ferry A EO

HSC Category B Craft

International Tonnage Certificate

Propulsion Power: 26,000 kW

Electrical Power: 4 x 190 kW

Passengers & Crew: 1000

Total Vehicles: 250 cars (1.5 tonne each) or 4 buses (22.4 tonnes each) and 200 cars

Gross Tonnage: 9,022 tonnes

Displacement: 1885 tonnes

Dead Weight: 518 tonnes

Fuel Oil: 66 tonnes

Water: 5800 litres

Lube Oil Storage Tanks: 1800 litres

Speed: 34 knots at 518 tonnes dead-weight at 100% MCR

Design: Two slender aluminum hulls connected by a strong bridging structure consisting primarily of major transverse web frames and 2 longitudinal CVK 's and a series of minor girders.

Fabrication: Welded aluminum construction using 5083 H116 and 5383 H116 plates and 6061-T6 sections. Longitudinal stiffeners supported by transverse web frames and bulkheads.

Subdivision: Each hull is divided into 8 vented, watertight compartments divided by transverse bulkheads and decks. The bridging structure between the hulls is fully welded to form a separate compartment. Watertight upper and lower voids are incorporated into the 5 void spaces ahead of the engine room in each hull between frames 20 and 73.

Vehicle Decks: Main vehicle deck and upper vehicle decks are constructed with straight-line camber with the external aft and side decks flat.

Superstructure: Welded or bonded aluminum construction with longitudinal and transverse framing. Passenger accommodations and wheelhouse are supported above the T3 strength deck on anti-vibration mounts.

Axle Loads Main vehicle deck: 7.1 tonnes center 2 lanes, 3.16 tonnes outboard lanes.

Upper vehicle deck 1.375 tonnes.

Vibration: Within DNV guidelines for structural vibration limits for High Speed Light Craft with the vessel fully loaded at service speed.

Hull Girder and Cross-structure Section Modulus Requirements
Acceleration Factor (DNV 3.1.2/B100)

$$a_{CG} = \frac{V}{\sqrt{L}} \frac{3.2}{L^{0.76}} f_g g_0 \text{ (m/s}^2\text{)}$$

where:

$f_G =$ Table B1, car ferry, Service Class R4

$g_0 = 9.8 \text{ m/s}^2$

$$a_{CG} = \frac{32}{\sqrt{96}} \frac{3.2}{96^{0.76}} 1.0 \times 9.8 = 2.8 \text{ m/s}^2$$

for service R4, $a_{CG \text{ min}} = 1.0 g_0 = 9.8 \text{ m/s}^2$

Wave Coefficient (DNV 3.1.2/A200)

$C_W =$ reduction factor $\times 0.08L$ for $L < 100 \text{ m}$

Reduction factor for R4 = $1.0 - 0.4 = 0.60$ (Table A1)

$C_W = 0.60 \times 0.08 \times 96 = 4.608$

Global Loads

Hull Girder Bending Moments

$M_{\text{tot Hog}} = M_{\text{HSW}} + 0.19 C_W L^2 (B_{\text{WL2}} + k_2 B_{\text{tn}}) C_B$

$M_{\text{tot Sag}} = M_{\text{SSW}} + 0.14 C_W L^2 (B_{\text{WL2}} + k_3 B_{\text{tn}}) (C_B + 0.7)$

where: $M_{\text{HSW}} = 0.5 \Delta L = 0.5 \times 1,882 \times 96 = 90,480 \text{ kN-m}$

$M_{\text{SSW}} = 0.0$

$B_{\text{WL2}} =$ sum of waterline breadths = $6.0 + 6.0 = 12.0 \text{ m}$

$B_{\text{tn}} =$ tunnel breadth = $25.8 - 2 \times 6 = 13.8 \text{ m}$

$Z =$ height of wet deck above base line = 6.64 m

$$k_2 = 1 - \frac{z - 0.5 T}{0.5 T + 2 C_W} = 1 - \frac{6.64 - 0.5 \times 3.76}{0.5 \times 3.76 + 2 \times 4.608} = 0.571$$

$$k_3 = 1 - \frac{z - 0.5 T}{0.5 T + 2.5 C_W} = 1 - \frac{6.64 - 0.5 \times 3.76}{0.5 \times 3.76 + 2.5 \times 4.608} = 0.663$$

$M_{\text{tot Hog}} = 90,480 + 0.19 \times 4.608 (96)^2 (12.0 + 0.571 \times 13.8) 0.403 = 154,180 \text{ kN-m}$

$M_{\text{tot Sag}} = 0 + 0.14 \times 4.608 (96)^2 (12.0 + 0.663 \times 13.8) (0.403 + 0.7) = 138,960 \text{ kN-m}$

Note: Kramer et al. list moment as 165,031 kN-m. This value will be used in further computations as they may have had greater insight to vessel particulars..

Required Section Modulus

Aluminum (DNV 3.3.4/B100)

$\sigma = 175 f_1$

$$f_1 = 0.48 \text{ (6061-T6)}$$

$$SM_R \text{ (aluminum)} = 165,031 \times 10^3 / (175 \times 0.48) = 1.965 \times 10^6 \text{ cm}^3$$

Steel (DNV 3.2.4/B11)

$$\sigma = 175 f_1$$

$$f_1 = 1.39 \text{ (NV-36)}$$

$$SM_R \text{ (steel)} = 165,031 \times 10^3 / (175 \times 1.39) = 0.678 \times 10^6 \text{ cm}^3$$

The actual section moduli calculated by Kramer et al. are:

$$SM_D = 3.468 \times 10^6 \text{ cm}^3$$

$$SM_K = 3.257 \times 10^6 \text{ cm}^3$$

Therefore the required section moduli do not control the scantlings. The subsequent calculations will show that plate thickness is significantly greater than that required, but the stiffener section moduli just meet the required values. This increase in plate thickness may be a result of global finite element calculations. The same increase in thickness above reule requirements that exists in the aluminum ship was applied to the steel variant.

Transverse Bending Moments

From Kramer et al. Table 6-3, the transverse bending moment is 76,900 kN-m.

DNV 3.3.4/E202, allowable stress = 160 fl

$$SM_R \text{ (aluminum)} = 76,900 \times 10^3 / (160 \times 0.48) = 1.001 \times 10^6 \text{ cm}^3$$

$$SM_R \text{ (steel)} = 76,900 \times 10^3 / (160 \times 1.39) = 0.346 \times 10^6 \text{ cm}^3$$

For the aluminum existing ship, the actual section moduli of the cross-structure according to the calculations of Kramer et al. are:

$$SM_{\text{Tier 3 Deck}} = 6.068 \times 10^6 \text{ cm}^3$$

$$SM_{\text{Wet Deck}} = 12.527 \times 10^6 \text{ cm}^3$$

Therefore, as with the longitudinal hull girder, the required values do not control the scantlings.

Design of Bottom Structure

Loads

Slam Pressure: DNV HSLC Section 3.1.2/C201

$$p_{sl} = 1.3 k_L (\Delta/nA)^{0.3} T_0^{0.7} [(50-\beta_x)/(50-\beta_{CG})] a_{CG}$$

Where:

k_L = longitudinal factor from Figure 3, $k_L = 1.0$ at midships.

$n = 2$ for catamaran

T_0 = draft at service speed = 3.76 meters

β_x = deadrise angle = 32°

β_{CG} = deadrise angle at the longitudinal center of gravity = 32°

a_{CG} = acceleration at the longitudinal center of gravity = 9.8 m/s^2

A = design area

$$p_{sl} = 1.3 (1.0) (1,882/2 A)^{0.3} (3.76)^{0.7} (1.0) 9.8 = 251 (A)^{-0.3}$$

$$A \geq 0.002 \Delta / T = 0.002 (1,882) / 3.76 = 1.00 \text{ m}^2$$

$$\text{For plating, } A_p = s l = 0.27 \times 1.2 = 0.324 \text{ m}^2$$

$$A_p \geq 2.5 s^2 = 2.5 (0.27)^2 = 0.182 \text{ m}^2$$

Therefore, for plating and stiffeners, $a = 1.0 \text{ m}^2$

$$p_{sl} = 251 (1.0)^{-0.3} = 251 \text{ kN.m}^2$$

Pitch Slam: (3.1.2/B203)

To extend aft of the forward perpendicular for $(0.1 + 0.15 V / \sqrt{L}) = (0.1 + 0.15 \cdot 34 / \sqrt{96})$
= 59.6 m aft FP.

$$p_{psl} = (21 / \tan \beta_x) k_a k_b C_W (1 - 20 T_L / L)$$

where:

$$k_a = 1.0 \text{ for plating}$$

$$= 1.1 - 20 (l_A / L) \text{ for stiffeners}$$

l_A = span of stiffener

$$k_a (\text{stiffeners}) = 1.1 - 20 (1.1 / 96) = 0.85$$

$k_b = 1.0$ for plating and longitudinal stiffeners

T_L = service speed draft at the FP. Assuming trim at speed = 3° ,

$$= 3.76 - (96/2) \sin (3) = 1.25 \text{ m}$$

$$p_{psl} (\text{plating}) = (21 / 0.629) (1.0)(1.0)(4.608 (1 - 20 (1.25) / 96)) = 113.8 \text{ kN/m}^2$$

$$p_{psl} (\text{stiffeners}) = (21 / 0.629) (0.85)(1.0)(4.608 (1 - 20 (1.25) / 96)) = 96.8 \text{ kN/m}^2$$

The bottom slamming pressure is greater than the pitch slamming pressure, so:

$$p_{sl} = 251 (1.0)^{-0.3} = 251 \text{ kN.m}^2$$

Sea Pressure Loads (hydrostatic)

$$p_H = 10 h_0 + k_S - 1.5 (h_0/T) C_W$$

where:

h_0 = distance to waterline at draft T

$k_S = 7.5$ at and after midships

$$C_W = 4.608$$

$$p_H = 10 (3.76) + 7.5 - 1.5 (3.76/3.76) 4.608 = 65.3 \text{ kN/m}^2$$

Aluminum Plating (DNV 3.3.5/B101)

Sea Load

$$t = s \sqrt{(C p / \sigma)}$$

where:

$$\sigma = 180 f_1$$

$$f_1 = 0.60 \text{ for 5083-H116}$$

$$C = 500 \text{ (Table B2, midpoint of longest edge)}$$

$$p = 65.3 \text{ kN/m}^2$$

$$s = 0.27 \text{ m}$$

$$t = 0.27 \sqrt{[500 \times 65.3 / (180 \times 0.60)]} = 4.7 \text{ mm}$$

Slam

$$t = 22.4 k_r \sqrt{(p_{SL} / \sigma f_1)}$$

where:

$$k_r = \text{curvature factor} = 1.0$$

$$p_{SL} = 251 \text{ kN/m}^2$$

$$\sigma = 200 f_1$$

$$t = 22.4 \times 1.0 \sqrt{(251 / 200 \times 0.60)} = 4.2 \text{ mm}$$

Minimum plate thickness

$$t_{\min} = t_0 + k L (s/S_R) / \sqrt{f}$$

where:

$$t_0 = 4.0, k = 0.03 \text{ (Table B1)}$$

$$S_R = 2 (100 + L) / 1000 = 2 (100 + 96) / 1000 = 0.392 \text{ m}$$

$$\sigma_f = \text{unwelded yield strength} = 215 \text{ MPa (5083-H116)}$$

$$f = \sigma_f / 240 = 215 / 240 = 0.896$$

$$t_{\min} = 4.0 + 0.03 \times 96 (-.27 / 0.392_R) / \sqrt{0.896} = 5.1 \text{ mm}$$

Therefore, the required aluminum plate thickness is 5.1 mm.

The existing plate on the ship is 8.0 mm, 3 mm thicker than the required thickness.

Steel Plate (DNV 32.5/B100)

Sea Pressure

$$t = 15.8 s \sqrt{(p / \sigma f_1)}$$

where:

$$\sigma = 120 \text{ (within midships 0.4L)}$$

$$f_1 = 1.39 \text{ (NV-36 steel)}$$

$$t = 15.8 \times 0.27 \sqrt{(65.3 / 120 \times 1.39)} = 1.7 \text{ mm}$$

Slam Loads

$$\sigma = 160$$

$$p_{SL} = 251 \text{ kN/m}^2$$

$$t = 15.8 \times 0.27 \sqrt{(251 / 160 \times 1.39)} = 3.0 \text{ mm}$$

Minimum thickness

$$S_R = 2(240 + L) = 2(240 + 96) = 672 \text{ mm}$$

$$t_{\min} = (5.0 + 0.04 L) (s / S_R) = (5.0 + 0.04 \times 96) (270 / 672) = 2.2 \text{ mm}$$

$$\text{Therefore, } t_{\text{required}} = 3.0 \text{ mm}$$

Because the aluminum plate is 3.0 mm greater than required, the steel plate will also be increased by the same amount.

$$t_{\text{steel}} = 3.0 + 3 = 6.0 \text{ mm}$$

Bottom Stiffeners

Aluminum

Sea pressure

$$SM = m l^2 s p / \sigma$$

$$m = 85 \text{ (bottom longitudinals)}$$

$$\sigma = 160 f_1$$

$$p = 65.3 \text{ kN/m}^2$$

$$f_1 = 0.48 \text{ (6061-T6)}$$

$$SM = 85 \times (1.2)^2 \times 0.27 \times 65.3 / (160 \times 0.48) = 28.1 \text{ cm}^3$$

Slam

$$p_{SL} = 251 \text{ kN/m}^2$$

$$m = 85$$

$$\sigma = 180 f_1$$

$$SM = 85 \times (1.2)^2 \times 0.27 \times 251 / (180 \times 0.48) = 95.9 \text{ cm}^3$$

The existing 6061-T6 stiffeners are 140 x 50 IT, which have $SM = 94.5 \text{ cm}^3$ on 270 mm 8 mm plate. Cross-sectional area = 12.9 cm^2 .

Steel Bottom Stiffeners (DNV 3.2.5/C201)

$$SM = 1000 l^2 s p / (m \sigma f_1)$$

where:

$$\begin{aligned}
m &= 12 \\
f_1 &= 1.39 \text{ (NV-36 steel)} \\
p &= 65.3 \text{ kN/m}^2 \\
\sigma &= 95 \text{ for } (Z_A / Z_R) = 1.0 \text{ (ratio of actual hull girder section modulus to required modulus)} \\
&= 160 \text{ for } (Z_A / Z_R) = 2.0
\end{aligned}$$

For the aluminum ship (see previous)

$$\begin{aligned}
Z_A &= 3.257 \times 10^6 \text{ cm}^3 \\
Z_R &= 1.965 \times 10^6 \text{ cm}^3 \\
(Z_A / Z_R) &= 3.257 / 1.965 = 1.657
\end{aligned}$$

Interpolating on the assumption that the actual section modulus for the steel ship would be the same percentage above rule requirement as on the aluminum ship:

$$\sigma = 137$$

$$SM = 1000 (1.2)^2 \times 0.27 \times 65.3 / (12 \times 137 \times 1.39) = 11.1 \text{ cm}^3$$

Slam

$$\begin{aligned}
\sigma &= 150 \\
p_{SL} &= 251 \text{ kN/m}^2
\end{aligned}$$

$$SM = 1000 (1.2)^2 \times 0.27 \times 251 / (12 \times 150 \times 1.39) = 39.0 \text{ cm}^3$$

On 270 mm 6.0 mm plate,
HP 100 x 8 bulb flat has $SM = 39.5 \text{ cm}^3$
weight = 7.65 kg / m

Side Shell Below Waterline

$$\begin{aligned}
s &= 0.270 \text{ m} \\
l &= 1.20 \text{ m}
\end{aligned}$$

Slam Loads

From Kramer et al. Table 6-2, $p_{Slam} = 50.5 \text{ kN/m}^2$ at 49 m aft the FP, slightly aft of midships.

Plating

Aluminum

$$\begin{aligned}
\sigma &= 200 f_1 \\
f_1 &= 0.6 \text{ (5083-H116)} \\
t &= 22.4 s \sqrt{(p_{SL} / \sigma f_1)} = 22.4 \times 0.27 \sqrt{(50.5 / 200 \times 0.60)} = 3.9 \text{ mm}
\end{aligned}$$

$$t_{min} = (t_0 + k L) / \sqrt{f (s/S_R)}$$

where:

$$t_0 = 4.0$$

$$k = 0.03$$

$$f = \sigma_f / 240 = 215 / 240 = 0.896$$

$$S_R = 0.392 \text{ m}$$

$$t_{\min} = (4.0 + 0.03 \times 96) / \sqrt{0.896 (0.270 / 0.392)} = 5.0 \text{ mm}$$

The existing plate thickness is 6.0 mm, 1 mm thicker than required.

Steel Side Shell Plate

Slam Load

$$\sigma = 160 f_1$$

$$f_1 = 1.39 \text{ (NV-36)}$$

$$t = 15.8 s \sqrt{(p_{SL} / \sigma f_1)} = 15.8 \times 0.27 \sqrt{(50.5 / 160 \times 1.39)} = 2.0 \text{ mm}$$

Minimum thickness

$$t_0 = 5.0$$

$$k = 0.04$$

$$S_R = 0.672 \text{ m}$$

$$t_{\min} = t_0 + k L (s/S_R) = (5.0 + 0.04 \times 96) (0.270 / 0.672) = 3.6 \text{ mm}$$

Because the existing aluminum plate is 1 mm thicker than required,

$$t_{\text{steel}} = 3.6 + 1 = 4.5 \text{ mm}$$

Side Shell Stiffeners

Aluminum

$$\sigma_{SL} = 180 f_1$$

$$f_1 = 0.48 \text{ (6061-T6)}$$

$$m = 85 \text{ (3.3.5/C201)}$$

$$p_{SL} = 50.5 \text{ kN/m}^2$$

$$SM = m l^2 s p_{SL} / \sigma_{SL} = 85 (1.2)^2 \times 0.27 \times 50.5 / (180 \times 0.48) = 19.3 \text{ cm}^3$$

Existing 70 x 40 IT on 270 mm x 6 mm plate has $SM = 23 \text{ cm}^3$

$$A_x = 5.20 \text{ cm}^2$$

Steel (DNV 3.2.5/C201)

$$\sigma_{SL} = 150 f_1$$

$$f_1 = 1.39 \text{ (NV-36)}$$

$$m = 12$$

$$p_{SL} = 50.5 \text{ kN/m}^2$$

$$SM = 1000 l^2 s p_{SL} / (m \sigma_{SL}) = 1000 (1.2)^2 \times 0.27 \times 50.5 / (12 \times 150 \times 1.39) = 6.52 \text{ cm}^3$$

HP 80 x 6 bulb flat
 SM >> 6.5 cm³ on 270 mm x 4.5 mm plate
 Weight = 4.88 kg/m

Wet Deck Structure

Slam Loads (DNV 3.1.2/C400)

$$p_{SL} = 2.6 k_L (\Delta/A)^{0.3} a_{CG} (1 - H_C / H_L)$$

where:

$$k_L = 0.5 \text{ at midships}$$

$$k_c = 0.3$$

A = design area

$$= s l = 0.241 \times 1.2 = 0.289 \text{ m}^2$$

$$= 2.5 s^2 (\text{plate}) = 2.5 (0.241)^2 = 0.145 \text{ m}^2$$

$$= 0.002 \Delta / T = 0.002 \times 1,882 / 3.75 = 1.00 \text{ m}^2$$

$$A = 1.00 \text{ m}^2$$

$$a_{CG} = 9.8 \text{ m/s}^2$$

$$H_C = \text{distance from waterline to wet deck} = 6.63 - 3.76 = 2.88 \text{ m}$$

$$H_L = 0.22 L (k_c - 0.8 L / 1000) = 0.22 \times 96 (0.3 - 0.8 \times 96 / 1000) = 4.714 \text{ m}$$

$$p_{SL} = 2.6 \times 0.5 (1,882/1.0)^{0.3} \times 9.8 (1 - 2.88 / 4.714) = 47.6 \text{ kN/m}^2$$

Wet Deck Plating

Aluminum

$$\sigma = 200 f_1$$

$$f_1 = 0.6 (5083\text{-H116})$$

$$t = 22.4 s \sqrt{(p_{SL} / \sigma f_1)} = 22.4 \times 0.241 \sqrt{(47.6 / 200 \times 0.60)} = 3.4 \text{ mm}$$

Minimum thickness

$$t_{\min} = [(t_0 + k L) / \sqrt{f}] (s/S_R)$$

where:

$$t_0 = 3.0$$

$$k = 0.0$$

$$f = \sigma_f / 240 = 215 / 240 = 0.896$$

$$S_R = 0.392 \text{ m}$$

$$t_{\min} = [(3.0 + 0.0 \times 96) / \sqrt{0.896}] (0.241 / 0.392) = 1.9 \text{ mm}$$

The existing plate is 7.0 mm, which is 3.6 mm thicker than required.

Steel Plating (DNV 3.2.5/B102)

$$\sigma = 160 \text{ (within midships } 0.4 L)$$

$$f_1 = 1.39 \text{ (NV-36)}$$

$$t = 15.8 s \sqrt{(p_{SL} / \sigma f_1)} = 15.8 \times 0.241 \sqrt{(47.6 / 160 \times 1.39)} = 1.8 \text{ mm}$$

Minimum thickness (There are no specific requirement for a steel wet deck, consider it to be a deck below the strength deck.)

$$S_R = 0.672 \text{ m}$$

$t_0 = 4.0$ for accommodation deck or sheathed cargo deck, which is not an apt description of the wet deck.

$$t_{\min} = (t_0 + 0.02L) S/S_R = (4.0 + 0.02 \times 96) (0.241 / 0.672) = 2.1 \text{ mm}$$

Because the aluminum plate is 3.6 mm thicker than required,

$$t_{\text{steel}} = 2.1 + 3.6 = 6.0 \text{ mm}$$

Wet Deck Stiffeners

Aluminum

$$l = 1.2 \text{ m}$$

$$s = 0.241 \text{ m}$$

$$p_{SL} = 47.6 \text{ kN/m}^2$$

$$\sigma_{SL} = 180 f_1$$

$$f_1 = 0.48 \text{ (6061-T6)}$$

$$m = 85$$

$$SM = m l^2 s p_{SL} / \sigma_{SL} = 85 \times (1.2)^2 \times 0.241 \times 47.6 / (180 \times 0.48) = 16.3 \text{ cm}^3$$

Existing 120 x 50 IT have $SM = 67.2 \text{ cm}^3$ on 230 mm 7 mm plate

$$A_x = 10 \text{ cm}^2$$

Steel

$$\sigma_{SL} = 150 f_1$$

$$f_1 = 1.39 \text{ (NV-36)}$$

$$m = 12 \text{ (fixed ends, uniform load)}$$

$$SM = 1000 l^2 s p_{SL} / (m \sigma_{SL} f_1) = 1000 (1.2)^2 \times 0.241 \times 47.6 / (1000 \times 150 \times 1.39) = 6.6 \text{ cm}^3$$

on 241 mm 4.5 mm plate,

100 x 6 bulb flat

$$SM = 25 \text{ cm}^3$$

$$\text{Weight} = 6.07 \text{ kg / m}$$

Comparative Weight of Structure

Consider each plate panel representative of remaining structure

Weight of Stiffened Plate Panel (kg)

Location	Aluminum		Steel	
	Scantlings	Weight (kg)	Scantlings	Weight (kg)
Bottom	8 mm plate 140 x 50 IT	11.01	6 mm plate HP 100 x 8 bulb flat	24.42
Side	6 mm plate 70 x 40 IT	6.83	4.5 mm plate HP 80 x 6 bulb flat	16.02
Wet Deck	7 mm plate 120 x 50 IT	8.57	6 mm plate HP 100 x 6 bulb flat	20.89
Total Weight (kg)		26.41		61.33

Weight of aluminum / weight of steel = $26.41 / 61.33 = 0.43$

Weight of steel / weight of aluminum $61.33 / 26.41 = 2.32$

For this study, the weight of the aluminum structure is a lower fraction of the weight of the equivalent steel structure than in the other studies. One reason may be the increase in plating thickness above minimum rule requirements. Without the original design calculations for the high-speed catamaran, it is difficult to tell why the aluminum plating was thicker than minimum rule thickness. It may have been done as a measure of conservatism in design. It does not appear to be fabrication-related, because there would be one minimum thickness, and some plating that was required to be thicker than this would then be at the rule minimum, and not increased.

The possibility is that plating was increased to meet the requirements of the finite element analysis, although that does not explain increases in areas such as the bottom plating, which is generally not affected by the transverse bending and torsional bending stresses that are important in twin hull structure. It is also possible that model tests or numerical analysis showed the hull bending and cross structure moments are significantly greater than the rule requirements, and the plating thickness was increased to provide the section modulus to meet those loads.

To properly assess the difference in steel and aluminum structure, a more extensive analysis would be required. However, with a high-speed hull form of this nature, the doubling in weight for steel structure would necessitate a significant redesign of the craft, which would have to be larger and have greater power and fuel capacity to be equivalent.

Design Study 3

Comparative Design of a 42.67 meter High-Speed Craft

A comparative design has been made of a 42.67-meter 32-knot crew boat. The design has been made using the ABS Guide for Building and Classing High-Speed Craft. However, the design has not been reviewed by the bureau, and should not be considered to meet all requirements for class. The steel craft was designed using a higher-strength steel, HS-36, which has a yield strength of 355 MPa. The aluminum craft was designed using 5083-H116 plate and 5083-H111 stiffeners, with welded yield strengths of 165 MPa and 145 MPa, respectively. These alloys are both of higher strength than the weakest alloy, but not the highest strength available. For the GRP alternative, the orthotropic properties were assumed of 207 MPa ultimate tensile strength, and 10.3×10^3 MPA elastic modulus. These properties are near the high end for hand lay-up, but easily achieved with lay-up methods such as vacuum-assisted resin transfer that are extensively used in GRP fabrication today.

Fabrication of both the aluminum and steel craft was assumed to be similar. Transverse frames and other girders were assumed to be built-up from cut plate with a balanced tee flange welded to the web. Corners of such members were assumed to have radiused brackets, a practice better suited to numerically controlled cutting of webs. The ABS HSC guide does not provide for this type of construction; straight brackets are assumed, with $\frac{3}{4}$ of the length of the bracket considered to be effective in reducing the span of the member. The same assumption of member length was made with the curved brackets.

For steel stiffeners, standard US AISC tee sections were used, with the equivalent metric nomenclature. For aluminum stiffeners, the rounded tee extrusions referenced in Chapter 2 of the guide were used. Other members, such as girders and transverse frames were web plates cut to shape with a symmetric flat bar flange. The flat bar was considered to be an extruded bar, and thus of 5083-H11, which has a lower yield strength than the 5083-H116 web.

For the GRP alternative, single-skin construction with hat stiffeners was used, with the hat sections also used for deep girders and transverse frames. Lighter construction could be achieved with foam-cored sandwich construction, but single-skin construction is more compatible with the level of technology used with the aluminum and steel alternatives. The typical nomenclature used, such as 125/100x75/11x11 hat, indicates a trapezoidal (hat) shaped foam-filled section that is 125 mm deep, 100 mm wide at the base, 75 mm wide at the top (flange) with side (webs) 11 mm thick, and top (flange) 11 mm thick. Greater efficiency and less weight could be achieved with such methods as unidirectional plies in the flange of higher strength and elastic modulus materials, such as Kevlar or carbon fibers, but such technology would be more advanced than that used for the aluminum or steel alternatives, and would be inconsistent.

The design cycle for many members was not completed. For example, design of a bottom transverse requires knowledge of the depth of the side transverse in order to determine the span. Initial assumptions were made for determining spans of members, and unless those assumptions were very unreasonable, further iterations were not made.

Principal Dimensions

Length on Waterline: $L_{WL} = 42.67$ meters
Length for Rules: $L = 41.39$ meters
Beam at Deck: $B = 7.62$ meters
Beam at waterline: $B_{WL} = 7.27$ meters
Depth midships: $D = 3.73$ meters
Draft midships: $d = 2.057$ meters
Displacement: 416.6 metric tonnes
Block Coefficient on waterline length: $C_B = 0.637$
Speed: $V = 32$ knots
Design sea state: $h_{1/3} = 3.96$ meters
Trim: $\tau = 4$ degrees
Deadrise at LCG: $\beta_{CG} = 19$ degrees
Transverse frame spacing = 1.219 m
Transverse bulkhead spacing = $5 \times 1.219 = 6.095$ m

Section Modulus Required (3/6.1.1)

$$SM_R = C_1 C_2 L^2 B (C_B + 0.7) K_3 K_4 C Q \text{ cm}^2 \text{ m}$$

$$C_1 = 11.35 - 0.11L = 6.797$$

$$C_2 = 0.01 \text{ (SI units)}$$

$$K_3 = 0.70 + 0.30 [(V/\sqrt{L} + 1.2) / 3.64] = 1.209$$

$$K_4 = 1.0 \text{ for unrestricted ocean service}$$

$$C = 1.0 \text{ for steel, } 0.90 \text{ for aluminum, and } 0.80 \text{ for FRP.}$$

$$Q = 0.72 \text{ for HS 36 steel}$$

For aluminum, $Q_{\min} = 635 / (\sigma_y + \sigma_u)$, where σ_y and σ_u are the welded yield and ultimate strength.

$$\text{Or } Q = 0.9 + q_5, \text{ where } q_5 = 115 / \sigma_y$$

$$\text{For 5086-H116 aluminum, } Q = 1.597$$

$$\text{For GRP, } Q = 400 / \sigma_U = 400 / 207 = 1.932.$$

Wave Bending Moments (3/6.1.2)

$$M_{w_{\text{sag}}} = k_1 C_1 L^2 B (C_b + 0.7) \times 10^{-3} \text{ kN-m}$$

$$M_{w_{\text{hog}}} = k_2 C_1 L^2 B C_b \times 10^{-3} \text{ kN-m}$$

$$M_{\text{stillwater}} = 0.5 M_{w_{\text{sag}}}$$

Where:

$$k_1 = 110$$

$$k_2 = 190$$

$$C_1 = 6.797 \text{ (as per 3/6.1.1 Section Modulus Requirement)}$$

$$M_{w_{\text{sag}}} = 110 \times 6.797 \times (41.39)^2 \times 7.62 (0.637 + 0.7) \times 10^{-3} = 13,050 \text{ kN-m}$$

$$M_{w_{\text{hog}}} = 190 \times 6.797 \times (41.39)^2 \times 7.62 \times 0.637 \times 10^{-3} = 10,740 \text{ kN-m}$$

$$M_{\text{stillwater}} = 0.5 M_{w_{\text{sag}}} = 6,525 \text{ kN-m (sag)}$$

**Required Hull Girder Section Modulus Midship
Based on Wave Bending Moments (3/6.1.3)**

$$SM = M_T K_3 C Q / f_p$$

Where:

$$K_3 = 0.70 + 0.3[(V/\sqrt{L} + 1.2) / 3.64] = 1.209$$

$$C = 1.0 \text{ for steel}$$

$$= 0.9 \text{ for aluminum}$$

$$Q = 0.72 \text{ for HS-36 steel}$$

$$= 1.597 \text{ for 5083-H116}$$

$$f_p = 17.5 \text{ kN/cm}^2$$

$$SM_{\text{steel}} = 19,580 \times 1.209 \times 1.0 \times 0.72 / 17.5 = 973 \text{ cm}^2 \text{ m}$$

$$SM_{\text{Al}} = 19,580 \times 0.9 \times 1.597 / 17.5 = 1,944 \text{ cm}^2 \text{ m}$$

The resulting required section moduli are shown in Table 1 below. For craft of length less than 61 meters, the requirements for determining the required section modulus using a calculated midship bending moment do not apply, but were computed for reference and to obtain estimated hull girder bending moments to use in other analyses, including fatigue.

The final designs, as shown in Figure 1 and Figure 2, have the section moduli to deck and keel that are shown in Table 1. The rule minima are slightly exceeded for a steel vessel of this size, and greatly exceeded in the GRP variant with no increase in deck or bottom scantlings above calculated requirements for local lateral loading on the structure. The results of the preliminary fatigue analysis increased the section modulus to deck of the aluminum variant by about 50 percent above the amount needed to meet local structural requirements.

Table 1 Section Moduli

	Section Modulus (cm ² -m)		
	Aluminum Variant	Steel Variant	GRP Variant
ABS Required SM	2,061	1,033	2,217
Actual SM (Deck)	3,513	1,659	4,796
Actual SM (Keel)	3,610	1,848	6,217

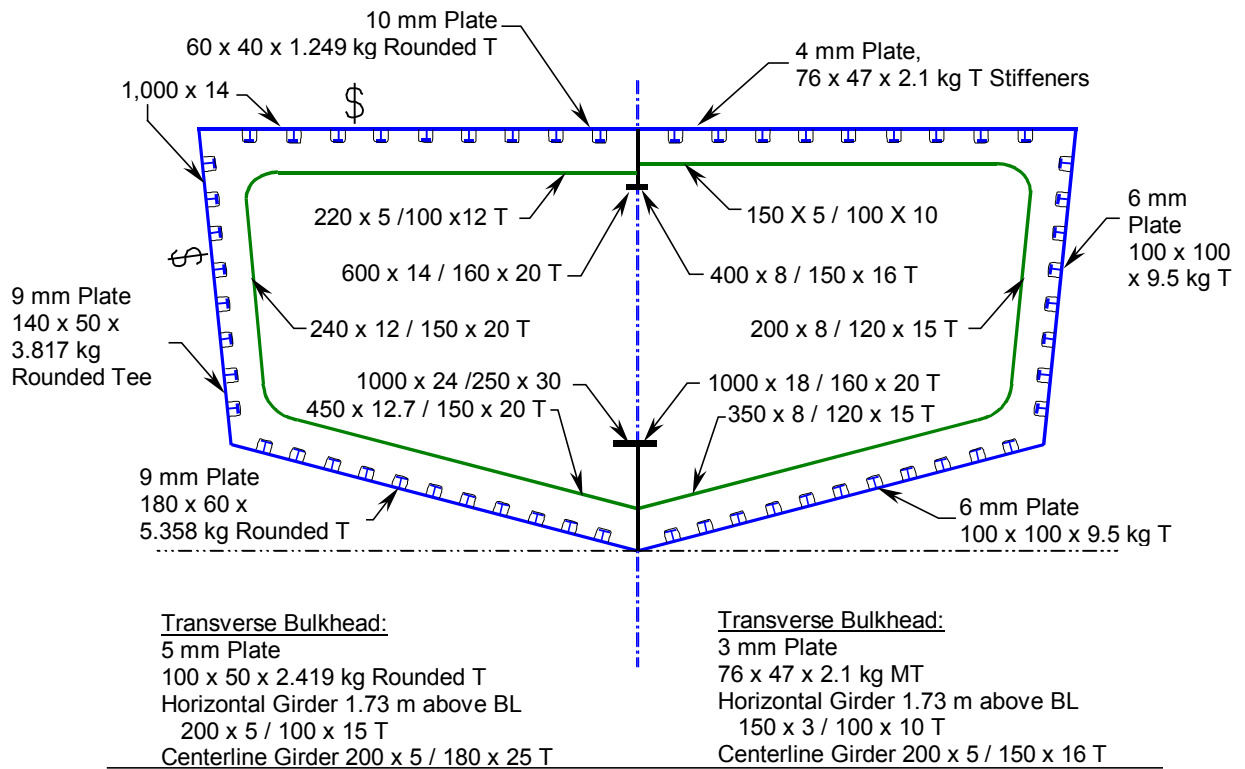

Figure 1 Midship section of aluminum and steel designs

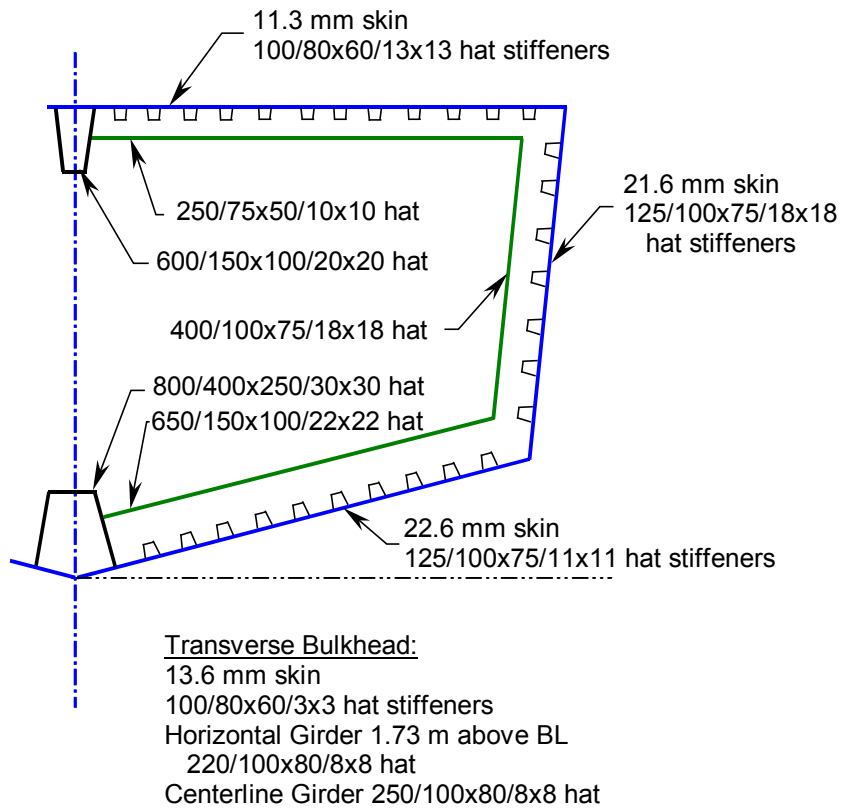

Figure 2 GRP variant midship section.

Bottom Structure

Design pressures and allowable stress levels are for hydrostatic loading and for slam loading. In all cases, the slam loading dominated the requirements; so only those calculations will be described.

Bottom pressure at the longitudinal center of gravity is described by the coefficient:

$$\eta_{CG} = N_2 [(12 h_{1/3} / B_{WL}) + 1.0] \tau (50 - \beta_{CG}) [V^2 (B_{WL})^2 / \Delta]$$

where:

$$N_2 = 0.0078$$

Δ = displacement (in kilograms, not tonnes, just to see that you are staying awake!)

$$\eta_{CG} = 0.947$$

The design slam pressure varies along the length. For this study, the value of the bottom slam pressure at the longitudinal center of gravity, p_{bCG} , is used at midships.

$$p_{bCG} = (N_1 \Delta / L_W B_W) (1 + \eta_{CG}) F_D$$

Where:

$$N_1 = 0.1$$

F_D is a factor determined from a graph relating the ratio of the design area, A_D , to a reference area, A_R .

$$p_{bCG} = 261.5 F_D$$

The reference area, $A_R = 6.95 \Delta / d = 1.408 \times 10^6 \text{ cm}^2$.

The following describes the bottom structure:

Plating, $s = 0.302 \text{ m}$, $l = 1,219 \text{ m}$, $A_D = 3,690 \text{ cm}^2$

$$\text{Maximum } A_D = 2 s^2 = 1,824 \text{ cm}^2$$

$$A_D / A_R = 1.29 \times 10^{-3}, \text{ Fig 3/8.1 gives } F_D = 1.0$$

$$t = s \sqrt{(p k / 1000 \sigma_a)}$$

$$\sigma_a = 0.90 \sigma_y = 320 \text{ MPa for steel, } 148 \text{ MPa for aluminum}$$

$$k = \text{aspect ratio factor} = 0.5 \text{ for } l/s \geq 2.0$$

Minimum plating thickness:

Steel

$$t_{\min} = 0.44 \sqrt{(KL)} + 2.0 \text{ mm}$$

where:

$$K = (n_y / y)^e$$

$$n_y = 235 \text{ MPa}$$

$$y = \text{yield strength, but } y < 0.7 \text{ ultimate strength}$$

$$= 355 \text{ MPa}$$

$$e = 0.75 \text{ for } y > 235$$

$$K = (235 / 255)^{0.75} = 0.734$$

$$t = 0.44 \sqrt{(0.734 \times 41.39)} + 2.0 \text{ mm} = 4.4 \text{ mm}$$

Aluminum

$$t_{\min} = 0.70 \sqrt{L} + 1.0 \text{ mm} = 0.70 \sqrt{41.39} + 1.0 = 7.4 \text{ mm}$$

For GRP single skins, a stiffener spacing of 320 mm is used, but the hat sections are 100 mm wide at the base, so for skin design a spacing, s , of 230 mm is used. Three different equations apply:

$$t = s c (p k / 1000 \sigma_a)^{1/2}$$

$$t = s c (p k_1 / 1000 k_2 E_F)^{1/3}$$

$$t = k_3 (c_1 + 0.26L) (q_1)^{1/2}$$

where

$$k = k_1 = 0.5$$

$$k_2 = 0.010$$

$$\sigma_a = 0.33 \sigma_U = 0.33 (207) = 68 \text{ MPa}$$

$$E_F = 13.8 \times 10^3 \text{ MPa}$$

$$k_3 = 1.1$$

$$c_1 = 3.2$$

$$q_1 = 170 / F$$

$$F = \text{flexural strength} = 262 \text{ MPa}$$

Bottom Plate thickness:

Steel: 6 mm

Aluminum, 9 mm

GRP = 22.6 mm, where the GRP thickness is controlled by the equation involving the flexural modulus of elasticity and the coefficient k_2 .

Bottom Longitudinals

The design area is the same as for plating; therefore the slam pressure is the same. The required section modulus is determined by the equation $SM_R = 83.3 p s l^2 / \sigma_a$. The factor 83.3 is the reciprocal of 12×10^{-3} , so this equation is just a variation of the fixed-end moment equation $m = w l^2 / 12$, adjusted for units so that the result comes out in cm^3 .

For bottom longitudinals under slam loading, $\sigma_a = 0.65 \sigma_y$ and the required section moduli are 78.7 cm^3 in steel, and 104.5 cm^3 in aluminum.

For steel, standard rolled shapes are used, and a 100 x 100 x 9.5 kg T is selected. For aluminum, the rounded tees listed in Chapter 2 are used, and a 180 x 60 x 5.358 rounded T is selected.

For GRP, the design equation is similar, with the allowable stress $\sigma_a = 0.33 \sigma_U = 0.33 (207) = 68 \text{ MPa}$, and the required section modulus is 155 cm^3 . The section selected is a hat section 125 mm deep, 100 mm wide at the base, 75 mm wide at the top, and 11 mm thick at the sides and top. It is assumed to be foam-filled with a foam with a density of 32 kg/m^3 (2 lb/ft^3).

Bottom Transverse.

Assuming that the side longitudinals are 230 mm deep, and that a 300 m bracket is fitted at the intersection of the bottom and side transverses, then $l = 3.504 \text{ m}$ and $s = 1.219 \text{ m}$, and $A_D = 42,700$, and $A_D / A_R = 2.61 \times 10^{-3}$, and $F_D = 0.998$, and $p_{\text{slam}} = 261 \text{ kN/m}^2$.

For bottom transverses, the allowable stress for slam loads is $0.80 \sigma_y$, so σ_a (steel) = 284 MPa, σ_a (aluminum) = 132 MPa. The required section moduli are 850 cm^3 for steel, and 1,828

cm³ for aluminum. In this case, the section modulus requirement for aluminum is based on 5083 H111 extrusions, as many shipyards find it more economical to order extruded flat bar for flanges rather than cutting plate. There are also requirements for minimum inertia of the section, but the sections selected provide inertia far in excess of that requirement for both steel and aluminum.

For GRP transverse frames, the allowable stress is the same for hydrostatic and slam loads, $\sigma_a = 0.33 \sigma_u = 0.33 \times 207 = 68$ MPa. The CVK is assumed to be 400 mm wide, the side transverse 200 mm deep, and no end brackets are used. The span, $l = 3.734 - (0.40 / 2) - 0.20 = 3.34$ m. $A_D / A_R = 334 \times 121.9 / 1.408 \times 10^6 = 0.029$. Figure 3.81 gives $F_D = 0.735$, and $p = 0.735 \times 261.5 = 192$ kN.m². Otherwise, the section modulus equation is the same as for metallic structure, and $SM_R = 3,200$ cm³. There are also requirements for inertia and for shear area, but the proportions of the member selected significantly exceed those.

There are requirements that must be met for the depth-to-thickness ratio of the web of the member, and the breadth-to-thickness ratio of the flange. The equation for this is:

$$b/t \leq C \sqrt{(\sigma_y / \sigma_d)},$$

where:

$\sigma_d = 235$ MPa for all steel alloys, and 127.6 MPa for all aluminum alloys.

$C = 70$ for steel webs, and 50 for aluminum webs

$C = 12$ for steel flanges, and 9 for aluminum flanges.

For GRP, the b/t ratios of stiffener crowns and webs are not a function of the strength or elastic modulus of the material.

Minimum b/t Ratios		
Alloy	Web	Flange
HS-36 steel	57	9.8
5083-H116 plate	44	
5083-H111 extrusions		8.4
GRP	30	20

The final sections selected are:

Steel: 350 x 8 / 120 x 15 T

Aluminum: 450 x 12.7 / 150 x 20 T

GRP: 650 / 150 x 100 / 22 x 22 hat section

Side Structure

Design pressures and allowable stress levels are for hydrostatic loading and for slam loading. In some cases, the slam loading dominates the requirements, in others, the hydrostatic loading dominates.

The slam pressure at any point, xx, along the length is given by the equation:

$$p_{xxx} = \frac{N_1 \Delta}{L_w B_w} \left(1 + \eta_{xx}\right) \left(\frac{70 - \beta_{xx}}{70 - \beta_{CG}}\right) F_D$$

where

$N_1 = 0.1$ (SI units)

β_{xx} = equals deadrise angle at point xx

F_D = factor for ratio of design area to reference area, same as for the bottom structure

Δ , L_w , and B_w = displacements (kg) and length and beam at waterline

At the LCG, $p_{CG} = [(0.1 \times 416,600) / (42.67 \times 7.27)] \times 1.947 F_D = 261 F_D$ (kN/m²)

Hydrostatic pressure is determined by the equation: $p_s = N_3 (F_3 H + d - y)$, Where the terms are as for the bottom hydrostatic pressure and y = distance to the baseline.

$$p_s = 9.8 (1.0 \times 4.365 + 2.057) - 9.8 y - 62.9 - 9.8 y \text{ (kN/m}^2\text{)}$$

Stiffener spacing, $s = 0.304$ m

Stiffener span, $l = 1.219$ m

Side plating at chine

$$A_D = 0.304 \times 1.219 = 0.37 \text{ m}^2 = 3,700 \text{ cm}^2$$

$$A_D \text{ (maximum)} = 2 s^2 = 2 \times (30.4)^2 = 1,848 \text{ cm}^2$$

$$A_D / A_R = 1,848 / 1.408 \times 10^6 = 1.3 \times 10^{-3}$$

Figure 3/8.1 gives $F_D = 1.0$

$$t = s \sqrt{(p k / 1000 \sigma_a)}$$

$$\sigma_a = 0.90 \sigma_y \text{ (Slam)}$$

$$\sigma_a = 0.40 \sigma_y$$

$$\sigma_y = 320 \text{ MPa for steel, } 148 \text{ MPa for aluminum}$$

$$\text{Steel Slam } t = 304 (261 \times 0.5 / (1,000 \times 319))^{1/2} = 6.1 \text{ mm}$$

$$\text{Hydro } t = 304 (261 \times 0.5 / (1,000 \times 142))^{1/2} = 4.1 \text{ mm}$$

$$\text{Aluminum Slam } t = 304 (261 \times 1.0 / (1,000 \times 148))^{1/2} = 9.0 \text{ mm}$$

$$\text{Hydro } t = 304 (261 \times 1.0 / (1,000 \times 66))^{1/2} = 6.0 \text{ mm}$$

For GRP, stiffener spacing will be 352 mm, with 100 mm for the width of the stiffeners, so that s for side skin design is 252 mm. F_D remains 1.0, so the side slam pressure is the same as for the metallic structure. As for the bottom, $\sigma_a = 0.33 \sigma_u = 68$ MPa. For the skin stiffness requirement, $t = s c (p k_1 / 1000 k_2 E_F)^{1/3}$, $k_2 = 0.015$, and skin thickness is determined by this requirement.

The thicknesses selected are:

HS 36 steel – 6 mm

5083-H116 aluminum – 9 mm

GRP – 21.6 mm.

Side Longitudinal Stiffeners

$$A_D = 0.304 \times 1.219 = 0.37 \text{ m}^2 = 3,700 \text{ cm}^2$$

For slam pressure, the maximum design area $A_D = 0.33 \times 1^2 = 0.33 (121.9)^2 = 4,904 \text{ cm}^2$

$$A_D / A_D = 3,700 / 1.408 \times 10^6 = 2.63 \times 10^{-3}$$

Figure 3/8.1 gives $F_D = 0.995$

At the first stiffener above the chine, $p_d = 261 \times 0.995 = 260 \text{ kN} / \text{m}^2$
 $p_s = 51.5 \text{ kN} / \text{m}^2$

Allowable stress (slam) = $0.60 \sigma_y$
(hydro) = $0.50 \sigma_y$

$$SM_R = 83.3 p s l^2 / \sigma_a$$

HS-36 steel

$$SM_R \text{ (slam)} = 46 \text{ cm}^3$$

$$SM_R \text{ (hydro)} = 10.9 \text{ cm}^3$$

5083-H111 aluminum

$$SM_R \text{ (slam)} = 75.3 \text{ cm}^3$$

$$SM_R \text{ (hydro)} = 26.9 \text{ cm}^3$$

For GRP, $F_D = 0.99$, and $p = 261 \text{ kN} / \text{m}^2$. $\sigma_a = 0.33 \sigma_u = 68 \text{ MPa}$.

The scantlings selected are:

HS-36 steel

100 x 100 x 9.5 kg T

5083-H111 aluminum

140 x 50 x 3.817 kg rounded Tee

GRP:

125 / 100 x 75 / 9 x 9 hat section.

Side Transverse

$$s = 1.219 \text{ m}$$

The span of the steel transverse is different from that of the aluminum because of the different depth of the bottom transverses.

$$l = 2.737 \text{ m (steel)}$$

$$l = 1.968 \text{ m (aluminum)}$$

$$A_D \text{ (steel)} = 121.9 \times 273.7 = 25,500 \text{ cm}^2$$

$$\text{Maximum } A_D = 0.33 l^2 = 14,440 \text{ cm}^2$$

$$A_D / A_R = 14,440 / 1.408 \times 10^6 = 0.0103$$

Fig 8/3.1 gives $F_D = 0.89$

$$p_{\text{slam}} = 261 \times 0.48 = 232 \text{ kN} / \text{m}^2$$

$$A_D \text{ (aluminum)} = 121.9 \times 1.968 = 23,990 \text{ cm}^2$$

$$\text{Maximum } A_D = 0.33 l^2 = 12,900 \text{ cm}^2$$

$$A_D / A_R = 12,990 / 1.408 \times 10^6 = 0.9.10 \times 10^{-3}$$

Fig 8/3.1 gives $F_D = 0.90$

$$p_{\text{slam}} = 261 \times 0.90 = 234.9 \text{ kN} / \text{m}^2$$

Allowable stress (slam) = $0.80 \sigma_y$
(hydro) = $0.50 \sigma_y$

$$SM_R = 83.3 p s l^2 / \sigma_a$$

HS-36 steel	SM_R (slam) = 364 cm ³
	SM_R (hydro) = 97cm ³
5083-H111 aluminum	SM_R (slam) = 797 cm ³
	SM_R (hydro) = 215 cm ³

The maximum b / t for
 Steel webs = 57
 Steel flanges = 9.76
 Aluminum web = 44
 Aluminum flanges = 8.4

For GRP, the depth of bottom transverses is 650 mm, and deck transverses are assumed to be 250 mm deep. No effective corner brackets are fitted to reduce span, and $l = 1.817$ m. $A_D / A_R = 181.7 \times 121.9 / 1.408 \times 106 = 0.0157$, and Figure 3/8.1 gives $F_D = 0.83$, so that $p = 0.83 \times 261.5 = 217$ kN/m². $\sigma_a = 0.33 \sigma_u = 68$ MPa.

The scantlings selected are:

HS-36 steel	200 x 8 / 120 x 15 T
5083-H111 aluminum	240 x 12 / 150 x 20 T
GRP:	400 / 100 x 75 / 18 x 18 hat section

Deck Structure

The design pressure for an exposed freeboard deck in accordance with Figure 3/8.2 is $p = 0.20 L + 7.6 = 0.20 (41.39) + 7.6 = 15.88$ kN/m²

$$l = 1.219 \text{ m}$$

$$s = 0.381 \text{ m}$$

For GRP, 80 mm-wide stiffeners are used, and
 s (skins) = 0.267 m
 s (stiffeners) = 0.347 mm.

Deck Plating

$$\sigma_a = 0.60 \sigma_y \text{ (welded)}$$

$$t = s (p k / (1000 \sigma_a))^{1/2}$$

For GRP, $\sigma_a = 0.33 \sigma_u = 68$ MPa. In the equation $t = s c (p k_1 / 1000 k_2 E_F)^{1/3}$, $k_2 = 0.010$. However, the skin thickness is determined by the equation

$$t = k_3 (c_1 + 0.26L) (q_1)^{1/2}$$

where

$$k_3 = 1.0$$

$$c_1 = 3.2$$

$$q_1 = 170 / F$$

$$F = \text{flexural strength} = 262 \text{ MPa}$$

Plating thickness selected
 HS 36 steel – 4 mm
 5083-H116 aluminum – 5 mm
 GRP – 11.3 mm.

Deck longitudinal stiffeners

$s = 0.381$ m
 $l = 1.219$ m
 $p = 15.88$ kN/m²
 $\sigma_a = 0.33\sigma_y = 117$ MPa (HS 36 steel)
 $= 47.8$ MPa (5083-H111 aluminum)
 SM_R (HS 36 steel) = 6.4 cm³
 (5083-H111 aluminum) = 15.7 cm³

For GRP, $\sigma_a = 0.40 \sigma_U = 0.40 (207) = 83$ MPa

The scantlings selected are:

HS-36 steel	76 x 47 x 2.1 kg MT
5083-H111 aluminum	60 x 40 x 1.249 kg rounded T
GRP	100 / 80 x 60 / 3 x 3 hat section.

Deck Transverses

$s = 1.219$ m
 $l = 3.52$ m
 $p = 15.88$ kN/m²
 $\sigma_a = 0.75\sigma_y = 266$ MPa (HS 36 steel)
 $= 109$ MPa (5083-H111 aluminum)
 SM_R (HS 36 steel) = 75.1 cm³
 (5083-H111 aluminum) = 183 cm³

For GRP, the deck centerline girder is assumed to be 150 mm wide, and the side transverse frames are 400 mm wide, so that $l = 3.81 - (0.15 / 2) - 0.40 = 3.335$ m. $\sigma_a = 0.33 \sigma_U = 0.33 (207) = 68$ MPa.

The scantlings selected are:

HS-36 steel	150 x 5 / 100 x 10 T
5083-H111 aluminum	220 x 5 / 100 x 12 T
GRP	250 / 75 x 50 / 10 x 10 hat section.

Transverse Bulkhead Structure

Design Pressure

The design pressure for transverse bulkheads is not explicitly stated in the HSC guide. However, it should be taken to the bulkhead deck, which in this case is the main deck. The design formula is therefore:

$$p_s = N_3 (D - y)$$

where:

$$N_3 = 9.8 \text{ (SI units)}$$

D = depth to the main deck

y = height above baseline

To reduce the weight of the bulkhead vertical stiffeners, a horizontal girder is fitted at the 1.73 m waterline. The exact height of this girder would be changed to suit craft arrangements and spacing of side shell longitudinal stiffeners, with which it should align.

Transverse Bulkhead Plating

$$s = 0.381 \text{ m}$$

$$l = 1.73 \text{ m}$$

$$l / s = 4.5 > 2; k = 0.5$$

$$\sigma_a = 0.60 \sigma_y \text{ (welded)}$$

$$t = s (p k / (1000 \sigma_a))^{1/2}$$

$$p = 9.8 \times 3.73 = 36.6 \text{ kN/m}^2$$

$$\sigma_a = 0.90 \sigma_y = 320 \text{ MPa (HS 36 steel)}$$

$$= 148 \text{ MPa (5083-H116 aluminum)}$$

For GRP, 80 mm-wide stiffeners are used, and

$$s \text{ (skin)} = 267 \text{ mm}$$

$$s \text{ (stiffeners)} = 347 \text{ mm.}$$

$$\sigma_a = 0.50 \sigma_U = 0.50 (207) = 105 \text{ MPa (WT bhd)}$$

In the equation $t = s c (p k_1 / 1000 k_2 E_F)^{1/3}$, $k_2 = 0.010$, and this equation controls the thickness.

Plating thickness selected

HS 36 steel – 3 mm

5083-H116 aluminum – 5 mm

GRP – 13.6 mm.

Transverse Bulkhead Vertical Stiffeners

The stiffeners will be designed to be sniped at the ends, so the rule-required section modulus is increased by 50 percent. This is because the equation for the bending moment in a simple supported beam is $wl^2 / 8$, compared to $wl^2 / 12$ for a fixed-end beam, a 50 percent increase in bending moment. The design equation is then:

$$SM_R = 83.3 \times 1.5 \times p s l^2 / (1000 \sigma_a^3)$$

where the factor of 1000 is introduced so that the result is in cm^3 when the units of length are in meters.

$$s = 0.381 \text{ m}$$

$$l = 1.63 \text{ m}$$

$$p = 9.8 (3.73 - 1.73 / 2) = 28.1 \text{ kN/m}^2$$

$$\sigma_a = 0.75 \sigma_y = 266 \text{ MPa (HS 36 steel)}$$

$$= 109 \text{ MPa (5083-H116 aluminum)}$$

$$\begin{aligned} SM_R \text{ (HS 36 steel)} &= 13.4 \text{ cm}^3 \\ \text{(5083-H111 aluminum)} &= 43.3 \text{ cm}^3 \end{aligned}$$

For GRP, $\sigma_a = 0.50 \sigma_U = 0.50 (207) = 104 \text{ MPa}$ (WT bhds).

The scantlings selected are:

HS-36 steel	76 x 47 x 2.1 kg MT
5083-H111 aluminum	100 x 50 x 2.419 kg rounded T
GRP	100 / 80 x 60 / 3 x 3 hat section

Transverse Bulkhead Horizontal Girder

Height = 1.73 m above baseline

$$s = (1.08 + 1.924) / 2 = 1.50 \text{ m}$$

$l = 3.3 \text{ m}$ assuming there is a 400 mm bracket at the ends with $l_e = 300 \text{ mm}$

$$y \text{ (mid-width)} = 1.73 + 1.924 / 2 - 1.08 / 2 = 2.15 \text{ m}$$

$$p = 9.8 (3.73 - 2.15) = 15.5 \text{ kN/m}^2$$

$$\sigma_a = 0.75 \sigma_y = 266 \text{ MPa (HS 36 steel)}$$

$$= 109 \text{ MPa (5083-H111 aluminum)}$$

$$SM_R \text{ (HS 36 steel)} = 79 \text{ cm}^3$$

$$\text{(5083-H111 aluminum)} = 194 \text{ cm}^3$$

For GRP, no end brackets are assumed, but reduction is made for a 100 mm-wide centerline girder and 125 mm deep side longitudinals, so $l = 3.6 - 0.125 - (100/2) = 3.425 \text{ m}$. $\sigma_a = 0.50 \sigma_U = 0.50 (207) = 104 \text{ MPa}$ (WT bhds).

The scantlings selected are:

HS-36 steel	150 x 3 / 100 x 10 T
5083-H111 aluminum	200 x 5 / 100 x 15 T
GRP	220 / 100 x 80 / 8 x 8 hat section

Fatigue Analysis

A preliminary fatigue analysis was performed using the hull girder bending moments computed above. The initial section modulus calculation had a section modulus to deck of $2,154 \text{ cm}^2 \text{ m}$ in the aluminum variant, and $1,659 \text{ cm}^2 \text{ m}$ in the steel variant. The bending moment range is $4,210 + 19,990 = 23,990 \text{ kN-m}$, so the stress range was 111 MPa for the aluminum variant and 143 MPa for the steel variant.

Using the figures developed in Chapter 9 of the report for number of cycles in a 20-year lifetime and for a Weibull coefficient, fatigue loading exceedance curves were developed for both variants, with 6.3×10^7 loading cycles and a Weibull coefficient of 1.13. For the aluminum variant, a Eurocode 9 class (23,3.4) detail was used, as this represents numerous structural details used in aluminum ships. For the steel variant, an ABS Class Detail was used. The fatigue analysis for the aluminum variant is shown below.

Ship	L = 41.39 m	Design Life (years)	Calculated Fatigue Life (Years) = 3.140					
Fatigue Classification of Structural Detail	Stress Range at 2×10^6	= 23.00	Range at 10^6	5 x = 17.57				
		$m_1 =$	3.4	$m_2 =$	5.4			
Maximum Stress Range (MPa)	111							
Total Cycles	63,000,000							
Weibull Coefficient	1.13							
S/S _{max}	Stress Range (n) (MPa)	Cycles Exceeded	# Cycles at Stress	Block Stress (MPa)	Lower Fatigue Cycles (N ₁)	Upper Fatigue Cycles (N ₂)	Fatigue Cycles (N)	Fatigue Damage
1.00	111.00	1.00E+00	1.25E+00	108.78	1.0154E+04	2.6480E+02	1.0154E+04	0.000123
0.96	106.56	2.25E+00	2.78E+00	104.34	1.1700E+04	3.3162E+02	1.1700E+04	0.000238
0.92	102.12	5.03E+00	6.17E+00	99.90	1.3564E+04	4.1940E+02	1.3564E+04	0.000455
0.88	97.68	1.12E+01	1.36E+01	95.46	1.5831E+04	5.3610E+02	1.5831E+04	0.000860
0.84	93.24	2.48E+01	2.99E+01	91.02	1.8614E+04	6.9333E+02	1.8614E+04	0.001607
0.80	88.80	5.47E+01	6.54E+01	86.58	2.2064E+04	9.0829E+02	2.2064E+04	0.002963
0.76	84.36	1.20E+02	1.42E+02	82.14	2.6389E+04	1.2069E+03	2.6389E+04	0.005383
0.72	79.92	2.62E+02	3.07E+02	77.70	3.1877E+04	1.6293E+03	3.1877E+04	0.009626
0.68	75.48	5.69E+02	6.59E+02	73.26	3.8937E+04	2.2387E+03	3.8937E+04	0.016919
0.64	71.04	1.23E+03	1.40E+03	68.82	4.8159E+04	3.1378E+03	4.8159E+04	0.029173
0.60	66.60	2.63E+03	2.98E+03	64.38	6.0416E+04	4.4980E+03	6.0416E+04	0.049250
0.56	62.16	5.61E+03	6.26E+03	59.94	7.7031E+04	6.6162E+03	7.7031E+04	0.081203
0.52	57.72	1.19E+04	1.30E+04	55.50	1.0007E+05	1.0025E+04	1.0007E+05	0.130361
0.48	53.28	2.49E+04	2.70E+04	51.06	1.3287E+05	1.5727E+04	1.3287E+05	0.203007
0.44	48.84	5.19E+04	5.53E+04	46.62	1.8103E+05	2.5703E+04	1.8103E+05	0.305219
0.40	44.40	1.07E+05	1.12E+05	42.18	2.5441E+05	4.4127E+04	2.5441E+05	0.440366
0.36	39.96	2.19E+05	2.25E+05	37.74	3.7135E+05	8.0454E+04	3.7135E+05	0.604844
0.32	35.52	4.44E+05	4.45E+05	33.30	5.6832E+05	1.5815E+05	5.6832E+05	0.782296
0.28	31.08	8.88E+05	8.67E+05	28.86	9.2448E+05	3.4251E+05	9.2448E+05	0.938227
0.24	26.64	1.76E+06	1.66E+06	24.42	1.6314E+06	8.4421E+05	1.6314E+06	1.019790
0.20	22.20	3.42E+06	3.13E+06	19.98	3.2276E+06	2.4950E+06	3.2276E+06	0.968698
0.16	17.76	6.55E+06	5.73E+06	15.54	7.5853E+06	9.6926E+06	6.55E+06	0.590685
0.12	13.32	1.23E+07	1.01E+07	11.10	2.3813E+07	5.9639E+07	1.23E+07	0.169640
0.08	8.88	2.24E+07	1.69E+07	6.66	1.3524E+08	9.4084E+08	2.24E+07	0.017941
0.04	4.44	3.93E+07	2.37E+07	2.22	5.6664E+09	3.5479E+11	3.93E+07	0.000067
0.00	0.00	6.30E+07					Cumulative Total Damage =	6.368940

The resulting fatigue life for this structural detail is 3.14 years. In order to have a 20-year fatigue life, the maximum stress range for the aluminum variant would have to be 68.6 MPa. With the 23,790 kN-m bending moment range, the required section modulus is 3,467 cm² m. To achieve this, the Main Deck plating was increased from 5 mm to 10 mm plate, and a 1-m wide shear strake and 1-meter wide stringer strake of 14 mm plate were added to the midship section.

This change changed the total weight of structure from 46.2 tons to 52.0 tons, an increase of 5.8 tons or 12 percent.

The calculation for the steel variant showed a fatigue life of 54 years for a Class F detail, so no increase in hull girder section modulus was required.

Fire Protection Insulation

Aluminum structure requires insulation to protect it from fire. The degree of protection depends upon the specific type of ship (cargo, passenger, etc.) and the general arrangements. For this study, the assumption will be made that the transverse bulkheads are required to meet Class A, and the underside of the main deck must also meet class A requirements.

Insulation with a density of 96 kg/m^3 (6 lb/ft^3) with an S value of 50 mm will be used.

On transverse bulkheads

$$F_c = F_E - f F_U^2$$

Where:

$$F_E = 1.0$$

$$f = 0.1$$

$$F_U = 1.0$$

$$F_c = 1.0 - 0.10 (1.0)^2 = 0.9 S$$

Therefore, the thickness on one side is $0.90 \times 50 = 45 \text{ mm}$. The weight is $0.045 \times 96 = 4.32 \text{ kg/m}^2$ (0.88 lb/ft^2) per side of the bulkhead. The same thickness will be used for vertical stiffeners.

For deep members, $F_c = 1.40 S = 1.40 \times 50 = 70 \text{ mm}$. The weight is $0.070 \times 96 = 6.72 \text{ kg/m}^2$.

For the underside of the deck, no reduction from S is made, and the thickness is 50 mm, and the weight is $0.050 \times 96 = 4.8 \text{ kg/m}^2$, taken on the underside only. The same insulation is used on the stiffeners. For the deep members, the same thickness and weight of insulation is used as on the deep members of the transverse bulkhead.

The requirements for fire protection of GRP are not as well defined as for aluminum, but the same weight was assumed as for aluminum, as the composite material must be protected to about the same temperature to prevent ignition.

Weight of Structure

The weight of structure per meter of length amidships will be computed. For early design stages, this weight is taken as uniform for a portion of the midships length, and then tapered at the ends in accordance with factors that vary with the type of ship. Assuming that those factors would be the same for an aluminum vessel as for steel, a comparison of the weight per meter midship is a reasonable basis for the comparison of total structural weight of an aluminum and a steel vessel. For this study, a factor of 0.80 was assumed.

This comparison is not complete in this study, as a proper comparison would involve a total design where the reduced weight of structure would reflect itself in reduced principal dimensions of the vessels, reduced powering, and reduced fuel consumption, all of which would reduce the scantlings for the vessel with the lighter structure even more.

The principal items are:

- Longitudinally continuous structure (taken from midship section calculations) (cross-sectional area plus area on ineffective structure times material density)
- Transverse frames (weight per frame times number of frames between bulkheads divided by bulkhead spacing)
- Transverse frames (weight of bulkhead divided by bulkhead spacing)
- Allowance for miscellaneous structure (10 percent)
- Allowance for welding (2.5 percent)
- Allowance for laps, etc. in GRP (5.0 percent)
- Non-structural foam inside GRP stiffeners at 32 kg / m³ (2 lb / ft³)

Table 2 Comparison of Weight of Aluminum, Steel and GRP Structure

Item	Weight (kg/m)		
	Aluminum Variant	Steel Variant	GRP Variant
Longitudinally continuous structure	954	1,726	1,031
Transverse frames	184	289	271
Transverse frames	87	165	105
Subtotal	1,225	2,180	1,407
Miscellaneous structure (10 percent)	123	218	141
Welding (2.5 %) (5 % for GRP laps, etc.)	31	55	70
Fire Protection Insulation	132		132
Total weight per meter	1,511	2,453	1,750
Total weight of Insulation (132 x 43m x 0.80)	4,541		4,541
Total weight of structure without insulation	47,438	49,983	55,659
Total weight of structure with insulation	52.0 t	84.4 t	60.2 t
Weight of structure / displacement	12.5 %	20.3%	14.5%
Weight of structure / weight of steel structure	0.62	1.0	0.71

The weight of the aluminum structure is 86 percent of the weight of the GRP structure. There are undoubtedly some items for which the weight was not estimated, such as the deckhouse and any intermediate deck. Therefore, the total weight of structure will be a higher percentage of total displacement. However, because the calculations were conducted in a consistent manner, the comparison between steel and aluminum is valid.

Design Study 4

Redesign of the Steel Deckhouse of a Destroyer in Aluminum

References:

- A. Dye, Lloyd C. and Benjamin W. Lankford Jr. A Simplified Method of Designing Ship Structure for Air Blast. Naval Engineers Journal, August 1966, pp. 693–701.
- B. Kihl, David P. Whole Ship Fatigue Analysis, David Taylor Research Center report SSPD-173-91-92, September 1991.
- C. Kammerer, Joseph.T. A Design Procedure for Determining the Contribution of Deckhouses to the Longitudinal Strength of Ships, Third Annual Technical Symposium of the Association of Senior Engineers of the Bureau of Ships, March 25, 1966.

Starting with early experimentation in the 1930s, the US Navy eventually came to the point where the standard material for all frigates, destroyers, and cruisers was 5456-H116 and 5456-H111 aluminum. In the 1980s that practice changed, and a steel deckhouse appeared on the destroyer class designed at that time. This study will look at the design of the deckhouse of that destroyer using aluminum. Unlike the earlier aluminum designs, fatigue and fire containment issues will be addressed. Only the forward deckhouse was redesigned, and only the first two levels of structure were redesigned. The results should be representative of the remainder of the deckhouse. Calculations were made using the US Navy design criteria used in the 1980s.

The aluminum alloy chosen for this study is 5083-H116 plate and 5083-H111 extrusions. This selection was made for several reasons.

1. 5456 is more expensive than 5083, yet is only slightly stronger. In March 2006, 5083-H111 extrusions were costing about \$3.00 per pound, but 5456-H111 was about \$4.00 per pound, 33 percent more. The welded yield strength of 5083-H111 extrusions is 21 ksi, and the welded yield strength of 5456-H111 is 24 ksi, only 14 percent more.
2. The fatigue strength of welded aluminum details is independent of yield strength, so the more expensive alloy would have no advantage where fatigue was a consideration in design.
3. The review of the existing steel deckhouse showed that most of the plating was sized for minimum thickness for fabrication. Anticipating the same condition in aluminum, no advantage would be gained from the more expensive alloy.

Conventional aluminum structure was used for the redesign so that a similar level of fabrication technology would be used as for the steel structure. A lighter weight alternative would have resulted if technology such as integrally stiffened aluminum deck and bulkhead panels were used.

If a final design were to be made, a cost-benefit analysis should be made.
It may be in some design situation the cost of small reductions of

high topside weight using a slightly more expensive alloy will be justified in the performance benefits that ensue. Other alloys should be included in that analysis, including 5059, 5383, and some 6xxx-series alloys for extrusions.

Design of Enclosed Structure

As will be discussed below, stiffeners and frames on the ship that are exposed to the atmosphere are designed to different criteria than the structure enclosed within the deckhouse. For most decks, the design load is 75 pounds per square foot (psf). That load was used for the comparative analysis, noting that some areas of structure had heavier scantlings than would be required to support that load. In those cases, the required section modulus of aluminum structural members was determined by multiplying the section modulus of the steel member the ratio of design allowable stresses in bending for 5083-H111 aluminum and higher strength steel (HSS).

Plating

The US Navy design equation for plating subject to lateral loads is given by the formula:

$$t = \frac{bK\sqrt{H}}{C}$$

where:

b = stiffener spacing (inches)

K = 1.0 for aspect ratio l/b ≥ 2.0

H = design head in feet salt water, 64 pounds per cubic feet

C = 400 for HSS (no permanent set under load)

290 for 5083-H116 (no permanent set under load)

Decks

The stiffener spacing for all decks is 27 inches

$$t = \frac{bK\sqrt{H}}{C} = \frac{27 \times 1.0 \sqrt{\frac{75}{64}}}{C}$$

$$= 0.07 \text{ in. for steel}$$

$$= 0.10 \text{ in. for aluminum}$$

The existing steel plating is 0.188 inch thick, a thickness selected as a minimum for fabrication purposes. For fabrication of aluminum structure using conventional welding methods and avoiding excessive distortion, a minimum thickness is generally 0.25 inches, which will be used.

House Side

The design load for structure above the main deck is a 30-psf wind load. Stiffener spacing between the 01 Level and the 02 Level is 18 in. The required thickness is

$$t = \frac{bK\sqrt{H}}{C} = \frac{18 \times 1.0 \sqrt{\frac{30}{64}}}{C}$$

= 0.03 in. for steel
= 0.04 in. for aluminum

The existing steel house side from the 01 Level to the 02 Level is 0.313-in plate. This thickness was used for fabrication reasons as well as to provide a transition from the 0.438 and 0.563-in shear strake below. For the aluminum, to provide similar transition, plate will be used that is 1/8-inch thicker than the steel plate. Therefore, the side plating from the 01 Level to the 02 Level will be 0.313 + 0.125 = 0.438-inch plate. Above the 02 Level, where the existing steel plate is 0.25, the aluminum plate will be 0.25 + .125 = 0.375-inch plate. The deckhouse front and back are 0.188-inch steel, so the aluminum will be 0.25-inch aluminum as was sized for the decks as a fabrication minimum thickness.

02 Level Inside Deckhouse Deck Longitudinals

Steel structure
0.188-inch plate

Longitudinal Stiffeners
l = 96 in
s = 27 in
Design load = 75 psf

$$\text{Moment} = w l^2 / 12 = (75/144) (27) (96)^2 / 12 = 10.8 \text{ in-kips}$$

Assume there is a 10.5 tsi = 23.5 ksi primary stress.

Existing 4 x 4 x 5# T on 50T 0.188" plate:

$$SM_f = 3.6 \text{ in}^3$$

$$r = 1.73 \text{ in}$$

$$l / r = 96 / 1.73 = 56, \text{ Design Data Sheet 100-4 gives } F_C = 39.0 \text{ ksi}$$

$$\text{bending stress } f_b = 10.8 / 3.6 = 3.0 \text{ ksi}$$

$$\begin{aligned} \text{The acceptance criteria} &= (f_c / 0.8 F_C) + (f_b / F_b) \\ &= (23.5 / 0.8 \times 39) + (3.0 / 40) = 0.82 < 1.0 \end{aligned}$$

Aluminum Structure (5083-H111 stiffeners)

Now assume the design primary stress is 11.0 ksi (NAVSEA Design Standard)

Using 4 x 4 x 2.0# T, on 35 T 0.25" plate:

$$SM_f = 4.57 \text{ in}^3$$

$$r = 1.78 \text{ in}$$

$$l / r = 96 / 1.78 = 54, \text{ Design Data Sheet 100-4 gives } F_C = 17.2 \text{ ksi}$$

bending stress $f_b = 10.8 / 4.57 = 2.36$ ksi

$$\begin{aligned}\text{The acceptance criteria} &= (f_c / 0.8 F_c) + (f_b / F_b) \\ &= (11.0 / 0.8 \times 17.2) + (2.36 / 18.0) = 0.93 < 1.0\end{aligned}$$

The acceptance criteria for steel and aluminum are similar, therefore, the aluminum 4 x 4 x 2.0# T are comparable to the existing steel stiffeners.

Deck Transverse Frames

Typical frame 12 x 4 x 22# I-T

$l = 177$ in

$b = 96$ in

$M = w l^2 / 12 = (75/144) (96) (177)^2 / 12 = 130.5$ in-kips

$SM_r = 130.5 / 40.0 = 3.2$ in³

Actual SM for 12 x 4 x 22# I-T on 50t 0.188-in plate = 26 in³

Therefore, the deck transverses are considerably oversized for the nominal design load. The actual design was based on a finite element analysis that considers continuity of structure and the total load situation. For the aluminum structure, adjust the required section modulus on the ratio of allowable bending stress.

$$SM_{Al} = 40/18 SM_{steel} = 2.2 SM_{steel}$$

Aluminum Transverse Frames

$$SM_R = 2.2 SM_{steel} = 2.2 \times 26 = 57 \text{ in}^3$$

Use 16 x 6 / 0.375 x 0.75 T

$$\text{On } 8.75" \text{ } 0.25" \text{ plate, } SM = 56.7 \text{ in}^3, I = 557 \text{ in}^4, A_x = 10.5 \text{ in}^2$$

Nuclear Air Blast Analysis

The ship analyzed is a naval combatant, and the structure was designed to resist the overpressure from a nuclear air blast. Dye and Lankford (1966) documented the methods used for design of aluminum deckhouse structure for those loads, and included qualitative information on the validation of those methods through experimentation on aluminum deckhouses. With the steel deckhouse of ship being redesigned, more rigorous methods were used. However, in the redesign process, the Dye-Lankford method was considered sufficiently accurate, considering the uncertainty of the actual design criteria used.

To determine appropriate design criteria, the existing steel structure in areas that would be exposed to nuclear air blast were analyzed to determine the load that could be withstood. These criteria were then used with the Dye-Lankford method to determine the aluminum scantlings. A key design parameter used is the dynamic yield strength, F_{DY} . For aluminum alloys, the US Navy uses a value averaging 1.27 times the welded yield strength. Therefore, for 5083-H116, $F_{DY} = 1.27 \times 21 = 26.7$ ksi. For Higher Strength Steel, $\sigma_Y = 51$ ksi, $F_{DY} = 54.2$ ksi.

An important parameter in the Dye-Langford method is the Dynamic Load Factor (DLF), which is the resistance of a structural element calculated using plastic design principles to the total static-equivalent load on the element. After completing the comparative analysis process, it was found that the DLF for the aluminum and steel structures were nearly the same, a result of the natural frequency in vibration of the equivalent structures being very close to each other. Consequently, a comparative design in aluminum could have been obtained by simply taking the ratio of the dynamic yield strengths of aluminum to steel and multiplying that ratio by the section modulus of the steel member to obtain a required section modulus for the aluminum member.

$$SM_{Al} = (54.2 / 26.7) SM_{Steel} = 2.0 SM_{Steel}$$

The resulting scantlings are shown below.

Location	Steel (HSS)		Aluminum (5083)	
	Member Size	Section Modulus (in ³)	Member Size	Section Modulus (in ³)
House Side, 01–02 Level				
Longitudinals	5 x 4 x 6#T	5.3	7 x 4.75 x 3.5#T	12.2
Vertical Frames	8 x 4 x 10# I-T	9.2	8 x 4.75 x 5.0#T	19.0
	8 x 4 x 13# I-T	11.6	10 x 5 x 5.75#T	23.0
House Side, 02–03 Level				
Longitudinals	4 x 4 x 5#T	3.8	6 x 4.5 x 3.0#T	9.2
Vertical Frames	10 x 4 x 15#T	15.8	12 x 4 x 10.0#T	36.7
	12 x 4 x 14# I-T	17	12 x 5 x 8# T	34.4
House Front, 01–03 Level, vertical stiffeners	4 x 4 x 5#T	3.6	5 x 4.5 x 2.5#T	7.0
02 Level				
Longitudinals	6 x 4 x 7#T	6.6	7 x 4.75 x 3.5#T	12.2
Transverse Frames	10 x 4 x 12# I-T	11.9	10 x 5 x 6.5#T	26.3

Fatigue Analysis

Fortunately, a detailed fatigue analysis (Kihl, 1991) has been made of the all-steel ship. The analysis included the development of a fatigue-loading spectrum using the computer program SPECTRA and finite-element modeling of the ship using the computer program MAESTRO. That analysis indicated no concern for the fatigue strength of the steel deckhouses. On the other hand, several areas in the hull structure were identified as having extremely short fatigue lives. However, the ships of this class have had a decade and a half of satisfactory service without any significant fatigue problems in service noted. This points out the conservative nature of the fatigue analysis used, particularly in the fatigue-loading spectrum developed by SPECTRA. Therefore, an analysis of the aluminum deckhouse based on this prior analysis should be considered a conservative analysis.

The (Kihl, 1991) analysis indicated a maximum stress in the steel deckhouse of 60 MPa (8.7 ksi) using the nominal design hull girder bending moment of 169,622 foot-tons hog. This stress existed in the 03 Level Frames 158–166, approximately Station 7.

Insufficient information about the basic hull properties was obtained for this study to make an evaluation of the effectiveness of the deckhouse using a method such as Kammerer (1966). Rather, a conservative proportioning of stress will be made based on the material properties and changes in design. The following considerations will be made.

1. If all other factors remained the same, for the same strain, aluminum has 1/3 the stress of steel, based on the ratio of elastic moduli.
2. The redesign changed deck thickness from 0.188 inches to 0.25 inches thick, an increase of 4/3. Because there is one-third the elastic modulus in aluminum, the effective area changed by the ratio $1/3 \times 4/3 = 0.44$.
3. Studies of the effectiveness of deckhouse structure show that including the effect of a continuous 2-level deckhouse that exists over a significant length of the ship in longitudinal strength calculations will decrease strength deck stress by 10 percent. Because the deckhouse of this ship is discontinuous, it should not make as great a contribution, although the fact that it is steel does increase its effectiveness.
4. Therefore, it is conservative to assume that changing from a steel to an aluminum deckhouse will increase strength deck stress by 10 percent.
5. Accordingly, the stress in the 03 Level of the deckhouse will be considered to change by a factor of $1.1 \times 0.44 = 0.48$.

The fatigue analysis will therefore assume that the maximum stress level in the 03 Level will be $60 \text{ MPa} \times 0.48 = 29 \text{ MPa}$. The fatigue exceedance curves of Reference (B) appear to be a straight line on a log-log plot, with a maximum lifetime number of cycles of 10^8 for a 30-year life. The maximum hull girder bending moments were 230,000 foot-tons in hog and 185,000 foot-tons in sag, a range of 415,000 foot-tons. The range is $41.5 / 23 = 1.8$ times the maximum hog moment.

The maximum stress computed using the nominal hull girder bending moment in hog must be proportioned upwards to the stress resulting from the maximum hog moment computed by SPECTRA. Therefore, the maximum stress in hog is $29 \times 230,000 / 169,622 = 39 \text{ MPa}$, and the maximum stress range is $39 \times 1.8 = 70 \text{ MPa}$.

Using this information, the fatigue life for an aluminum structural detail having a Eurocode 9 classification of 23-3.4 is shown in Table 3 to have a fatigue life of 38 years. Eurocode 9 is representative of many typical structural details used in aluminum ship structure, and as a very conservative classification for the detail of the intersection of an aluminum longitudinal deck stiffener with a transverse bulkhead vertical stiffener. Consequently, the aluminum deckhouse should have a very good fatigue life.

Table 3 Fatigue Life Calculation for Aluminum Deckhouse

Ship	L = 142 m		Design Life (years)	30	Calculated Fatigue Life		38.54	
Fatigue Classification of Structural Detail	Stress Range 23.00 at 2×10^6		Range at 5×10^6		17.57			
			$m_1 =$	3.4	g_{Ff}	1.00		
			$m_2 =$	5.4	g_{Mf}	1.00		
Maximum Stress Range (MPa)	70							
Total Cycles	100,000,000							
Weibull Coefficient	1.0							
S/S _{max}	Stress Range (n) (MPa)	Cycles Exceeded	# Cycles at Stress	Block Stress (MPa)	Lower Fatigue Cycles (N ₁)	Upper Fatigue Cycles (N ₂)	Fatigue Cycles (N)	Fatigue Damage
1.00	70.00	1.00E+00	1.09E+00	68.60	4.8686E+04	3.1925E+03	4.8686E+04	0.000022
0.96	67.20	2.09E+00	2.28E+00	65.80	5.6097E+04	3.9981E+03	5.6097E+04	0.000041
0.92	64.40	4.37E+00	4.75E+00	63.00	6.5035E+04	5.0564E+03	6.5035E+04	0.000073
0.88	61.60	9.12E+00	9.93E+00	60.20	7.5906E+04	6.4633E+03	7.5906E+04	0.000131
0.84	58.80	1.91E+01	2.08E+01	57.40	8.9249E+04	8.3590E+03	8.9249E+04	0.000233
0.80	56.00	3.98E+01	4.34E+01	54.60	1.0579E+05	1.0951E+04	1.0579E+05	0.000410
0.76	53.20	8.32E+01	9.06E+01	51.80	1.2653E+05	1.4551E+04	1.2653E+05	0.000716
0.72	50.40	1.74E+02	1.89E+02	49.00	1.5284E+05	1.9644E+04	1.5284E+05	0.001239
0.68	47.60	3.63E+02	3.95E+02	46.20	1.8669E+05	2.6991E+04	1.8669E+05	0.002118
0.64	44.80	7.59E+02	8.26E+02	43.40	2.3091E+05	3.7830E+04	2.3091E+05	0.003579
0.60	42.00	1.58E+03	1.73E+03	40.60	2.8968E+05	5.4230E+04	2.8968E+05	0.005960
0.56	39.20	3.31E+03	3.61E+03	37.80	3.6935E+05	7.9767E+04	3.6935E+05	0.009766
0.52	36.40	6.92E+03	7.54E+03	35.00	4.7981E+05	1.2087E+05	4.7981E+05	0.015706
0.48	33.60	1.45E+04	1.57E+04	32.20	6.3708E+05	1.8961E+05	6.3708E+05	0.024714
0.44	30.80	3.02E+04	3.29E+04	29.40	8.6801E+05	3.0989E+05	8.6801E+05	0.037899
0.40	28.00	6.31E+04	6.87E+04	26.60	1.2199E+06	5.3201E+05	1.2199E+06	0.056343
0.36	25.20	1.32E+05	1.44E+05	23.80	1.7805E+06	9.6998E+05	1.7805E+06	0.080650
0.32	22.40	2.75E+05	3.00E+05	21.00	2.7250E+06	1.9068E+06	2.7250E+06	0.110100
0.28	19.60	5.75E+05	6.27E+05	18.20	4.4326E+06	4.1295E+06	4.4326E+06	0.141411
0.24	16.80	1.20E+06	1.31E+06	15.40	7.8223E+06	1.0178E+07	1.0178E+07	0.128671
0.20	14.00	2.51E+06	2.74E+06	12.60	1.5476E+07	3.0080E+07	3.0080E+07	0.090964
0.16	11.20	5.25E+06	5.72E+06	9.80	3.6369E+07	1.1686E+08	1.1686E+08	0.048920
0.12	8.40	1.10E+07	1.19E+07	7.00	1.1418E+08	7.1903E+08	7.1903E+08	0.016611
0.08	5.60	2.29E+07	2.50E+07	4.20	6.4842E+08	1.1343E+10	1.1343E+10	0.002200
0.04	2.80	4.79E+07	5.21E+07	1.40	2.7169E+10	4.2775E+12	4.2775E+12	0.000012
Total Cycles =		1.00E+08				Total Fatigue Damage =		0.778488

If a detailed design were made of the aluminum deckhouse, the completed design should be modeled with the finite element method to better estimate the overall stress levels as well as stress levels at areas of stress concentration. Areas showing poor fatigue performance would then be either modified in design to improve the fatigue classification of the detail or locally reinforced to reduce stress levels. Based on the analysis above, no major modification to the scantlings of the deckhouse would be required to improve fatigue life.

Fire Protection Insulation

If a US Navy ship were built today with an aluminum deckhouse, fire protection insulation would be required for the aluminum structure, both to provide fire barriers and to protect the aluminum structure from melting. For this study, Structo-Guard insulation produced by Thermal Ceramics, Inc. will be used. According to the manufacturer, this product has a NAVSEA rating of N-30 if a bulkhead is insulated with two 1.5-inch thick layers on each side, a total of 6 inches of insulation on a bulkhead. It will be assumed that house sides and ends will be insulated internally, and will require only 3 inches of this insulation. The underside of decks will be insulated with 3 inches of insulation on the underside, and all stiffeners, frames, and girders on decks, bulkheads, house sides and ends, and stanchions will be surrounded with 3 inches of insulation. The insulation weighs 6 pounds per cubic foot, and the following weights are used:

Unit Weight of Fire Protection Insulation

Location	Weight of Insulation
Internal transverse bulkheads	3.0 lbs / ft ²
Decks, house sides and ends	1.5 lbs / ft ²
4 x 4 T stiffeners	2.00 lbs / ft
6 x 4.5 T stiffeners	2.63 lbs / ft
7 x 4.75 T stiffeners	2.94 lbs / ft
8 x 4.75 T frames and stiffeners	3.19 lbs / ft
10 x 5 T frames	3.75 lbs / ft
12 x 5 T frames	4.25 lbs / ft
14 x 6 T frames	5.00 lbs / ft
14 x 8 T frames	5.50 lbs / ft
18 x 12 girders	7.50 lbs / ft

Weight of Structural Fire Protection Insulation on Aluminum

Location	Weight (pounds)
Decks (including stiffening and stanchions below)	34,107
Major Transverse Bulkheads	8,282
Miscellaneous Transverse and Longitudinal Bulkheads	24,421
House Sides and Ends	11,995
Total Weight of Insulation	78,805

Final Weight of Structure and Insulation (pounds)

Item	Steel	Aluminum
02 Level		
Plate	46,770	21,154
Longitudinal Stiffeners and Girders	13,700	8,940
Transverse Frames	10,754	6,826
03 Level		
Plate	36,100	16,332
Longitudinal Stiffeners and Girders	8,470	4,994
Transverse Frames	9,536	6306
House Side 01-03 Level		
Plate	32,688	15,586
Longitudinal Stiffeners	10,400	6,232
Vertical Frames	2,860	1,990
Stanchions	1,118	787
Transverse Bulkheads	37,474	16,671
Longitudinal Bulkheads	54,473	23,897
Subtotal Structure	264,343	129,705
Miscellaneous Structure (10%)	26,434	12,970
Welding, mill tolerance (2.5%)	6,608	3,243
Total Structure	297,400	145,900
Fire Protection Insulation		78,805
Total Weight of Structure and Insulation	296,130	224,700

Weight of Aluminum Structure / Steel Structure = $145,900 / 297,400 = 0.490$

Weight of Aluminum Structure Plus Insulation / Steel Structure = $224,700 / 296,130 = 0.759$

The addition of fire protection insulation significantly reduces the weight advantages of aluminum, as the insulation weighs about one-half the weight of the aluminum structure. If aluminum structure is to be used for naval applications, a lighter weight solution needs to be found.

Appendix B

Course Notes

The subject matter of the aluminum guide has been converted to note form for use in making presentations or to conduct a course on aluminum marine structures. There are approximately 374 pages of notes. If a 30-hour 1-week course were given, that would allow for presentation at a rate of 12.5 slides per hour, or an average of 75 slides per day. The following is a suggested class schedule.

Session	Day	Chapter	Subject
1	1 Morning	1	Introduction
2	1 Afternoon	2	Material Characteristics
3	2 Morning	3	Structural Design
		4	Structural Details
4	2 Afternoon	5	Welding and Fabrication
		6	Riveting
		7	Joining Aluminum to Steel Structure
5	3 Morning	8	Residual Stresses and Distortion
6	3 Afternoon	9	Fatigue and Fracture
7	4 Morning	10	Fire Protection
8	4 Afternoon	11	Vibration
9	5 Morning	12	Maintenance and Repair
		13	Mitigating Slam Loads
10	5 Afternoon	14	Emerging Technologies

Aluminum Marine Structure Design and Fabrication Guide

Subjects Covered

1. Introduction
2. Material Characteristics
3. Structural Design
4. Structural Details
5. Welding and Fabrication
6. Riveting
7. Joining Aluminum to Steel Structure
8. Residual Stresses and Distortion
9. Fatigue and Fracture Design and Analysis Procedures
10. Fire Protection
11. Vibration
12. Maintenance and Repair
13. Mitigating Slam Loads
14. Emerging Technologies

I. Introduction

Background

- First sizable craft constructed of aluminum—1892
 - sloop-rigged yacht *Vendenesse*
 - Built at St. Denis in France
 - Six-percent copper alloy
 - Construction was riveted.
 - Corrosion was observed over 20 m² (200 ft²) of her bottom within four months after launch
 - Paint had failed
- 1895 Herrshoff America's Cup yacht *Defender*
 - Side shell plating and some of the frames of aluminum
 - 4 percent nickel alloy
 - Yield strength of about 205 MPa (30 ksi)
 - Hull plating below the waterline was bronze
 - Rivets for the aluminum were bronze
 - Cup was won by *Defender*
 - Boat wasted away afterwards
- Yarrows in England
 - Aluminum torpedo boats for French Navy
 - 6-percent copper alloy
 - Iron rivets and a mild steel frame
 - French began a series of their own design
 - Lead ship, *Foudre*, completed in 1895
 - 18-meter (60-foot) second class torpedo boat

Background (Cont.)

- Spent the winter of 1895 moored at Cherbourg
- Spring of 1896, she was found to be extensively corroded
 - Especially between the riveted seams of the plates
- The boat was scrapped
- 5 sister ships were ordered of steel.

- U.S. Navy
 - Stanchions, sockets and decklight frames for the torpedo boats of battleship USS Maine
 - Quickly corroded and were replaced with steel
 - Torpedo boats *Dahlgren* and *Craven*
 - First aluminum deckhouses for U.S. Navy ships
 - Designed and built by Bath Iron Works in 1898
 - Aluminum was not used again in structural applications for forty years.
 - 1935 destroyers
 - Aluminum replaced brass in pilot house near magnetic compass
 - Aluminum furniture and joiner bulkheads
 - DD-409 class, designed in 1936
 - Deckhouse plating was mixed
 - Some aluminum
 - Some mild steel
 - Framing of mild steel

Background (Cont.)

- DD-423 Class
 - Aluminum plating throughout the entire deckhouse
 - Thick steel was used for fragment protection
 - Riveted to steel frame
- 1940 technical bulletin of Bureau of Ships
 - U.S. Navy experience up to 1940 with riveted aluminum.
 - Improper methods of design, fabrication, or upkeep
 - Improper alloy selection
 - Insufficient rigidity
 - Use of welding
 - Use of tap bolts
 - Improper riveting
 - Overheating
 - Severe corrosion resulted when gasketing materials on faying surfaces were not impregnated with a suitable paint
 - Early years of aluminum use had troubles
- Fletcher (DD-445) class destroyers
 - Mild steel transverse frames spaced 21 inches
 - Aluminum plating 4.8 mm (3/16 inches) thick
 - In way of gun blast 6.3 mm (1/4 inches) thick.

Background (Cont.)

- World War II
 - All uses of aluminum except for aircraft came under careful
 - Use of aluminum in Navy ships was temporarily discontinued
 - DD-445 class a mixture of steel and aluminum
- USS Gearing (DD-692) and USS Sommer (DD-710) class destroyers
 - Riveted aluminum for about half of the deckhouse sides and decks
 - Transversely framed stiffeners were welded steel
- 1948 USS Mitcher (DL-2) class
 - Aluminum deckhouses entirely welded
 - Transversely oriented aluminum frames
- Dealy (DE-1008) started with steel deck houses
 - USS Courtney (DE 1021)
 - Contracted in 1953
 - Aluminum deckhouse
 - Subsequent ships of the class aluminum
- All new U.S. Navy combatants (destroyers, destroyer escorts, frigates and cruisers)
 - Aluminum for the majority of their deckhouses
 - Aluminum used for the deckhouse in landing ships
 - Islands of some amphibious assault ships

Background (Cont.)

- DDG 51 Class
 - 1985
 - Steel deckhouse
 - Concerns for
 - Fatigue
 - Fire
- Some US merchant ships at close of World War II
 - Aluminum in their deckhouses
 - Practice continued after the war
 - Primarily in the superstructures of passenger ships
- Aluminum adopted worldwide for fabrication of the superstructure of passenger ships
- Aluminum used in the 1940s for pleasure craft and for workboats
- Aluminum high-speed ferries in 1990s
- Many navies are adapting derivatives of high-speed ferries combatant craft.

Material Characteristics

- The U.S. Aluminum Association
 - Maintains the international standards for aluminum alloys
 - Temper designation
 - Chemical composition
 - Material properties
- Recent corrosion problems of a particular aluminum alloy
 - Revision of the standards of the American Society of Testing and Materials
 - Standards are being adopted internationally
 - International Association of Classification Societies
- Marine-grade aluminum alloys generally good corrosion resistance
 - No standards for evaluating corrosion resistance in a marine environment
 - Developers of new alloys have no solid means of determining long-term suitability of their products for use in a marine environment
- Hull construction product forms
 - Plate
 - Extrusions
 - Hot metal is pressed through a die
 - Process is versatile
 - New shapes easily designed and extruded
 - Variety of different extrusions used in marine construction
 - Few to any standard cross-section

Structural Design

- Structural design with aluminum similar to design with steel
 - Reduced elastic modulus of aluminum
 - Reduced buckling strength and stiffness
 - Strength of welds and the adjacent heat-affected-zone significantly less than in the base metal
- Design codes generally use welded strength
 - Sometimes properties of base metal used

Structural Details

- Many structural details the same for aluminum and steel.
 - Fatigue is a far greater concern in aluminum
 - Use details with lower stress concentrations.
- Some structural details are unique to aluminum structure
 - Lightweight deck panels
 - Intermittent longitudinal members
 - Lighter structure at a reduced total cost
- Details often have discontinuities for which detailed fatigue analysis should be performed
 - Fatigue testing of aluminum details is needed

Welding and Fabrication

- Weld processes
 - Gas-metal arc welding (MIG)
 - Gas-tungsten arc welding (TIG)
 - Used for thinner material
 - Welding parameters and techniques are different from steel
 - Retraining of welders is required
 - Most shipyards do not have the same welders work with both metals
 - Friction stir welding becoming popular
- Greater cleanliness required for aluminum
 - More care required to reduce welding distortion
 - Low elastic modulus means greater distortion
 - Greater chance of buckling from residual stresses
- Modified forms of woodworking tools used for cutting aluminum
- Numerically controlled plasma-arc cutting or fluid jet cutting
 - Very accurate dimensions
- Aluminum plate is easily bent
 - Cracking can occur if the bend radii are too small
- Aluminum generally cannot be heated for forming
 - Flame straightening is limited
 - Compound curvature avoided because of difficulties associated with heating
 - Limitation on the lines of aluminum vessels.

Welding and Fabrication (Cont.)

- Fabrication methods
 - Most shipyards prefer to use stick construction
 - Bulkheads, frames, and stiffeners are laid up and welded together
 - Plate is welded to them
 - Some shipyards using prefabricating subassemblies
 - Practice is limited today
 - Smaller yards producing one-off designs.

Riveting

- Seldom used today for fabricating marine structures
 - Care needed to minimize corrosion
 - Metal joined and fasteners should be of the same alloy or of alloys with the same electrochemical potential in seawater
 - Faying surfaces treated with preservatives prior to joining
 - Working of the structure over time
 - Break down this preservation
 - Crevice corrosion
- Mechanical fastening generally with swaged fasteners
 - More consistent tension after installation than rivets
 - Require less labor
 - Do not require as high a skill level as with riveting

Joining Aluminum to Steel Structure

- Aluminum superstructure of a naval combatant or a passenger ship
 - Bimetallic strip welded between and aluminum
 - Good fatigue resistance
 - Good corrosion resistance
 - Not used underwater or exposed to standing water.
- Aluminum superstructure on steel hull
 - Stresses in the aluminum lower than in steel hull
 - Lower elastic modulus of aluminum
 - Reduced fatigue strength of aluminum
 - Care must be taken in design

Residual Stresses and Distortion

- Aluminum has lower elastic modulus compared to steel
- Benefits and drawbacks
 - Residual stress from welding is lower
 - Greater distortion and buckling of thin structure from stresses that exist
- Ability to predict distortion in steel structure is limited
 - Prediction models rely on experimental data
 - Less data for aluminum
- State-of-the-art in prediction of distortion in aluminum has not advanced
 - Rules of thumb
 - Weld sequencing
 - Experience with fabricating similar structure is the best guide today
- Aluminum fabrication tolerances are greater than for similar steel structure
 - Impact of increased tolerances on strength not well addressed

Fatigue and Fracture Design and Analysis Procedures

- Fatigue crack growth rates in aluminum
 - Up to 30 times faster than steel
 - Same stress level
 - Same initial size crack size
- Prevent crack initiation
 - Fatigue analysis during design
 - Reduce stress levels
 - Use better structural details
- Fatigue analysis needs projected loading history
 - Analytical methods today
 - Challenged by high speeds and unusual hull forms
 - Advanced methods
 - Expensive
 - Time-consuming
- Aluminum good tolerance to resist fracture from single overloads
 - Slam loads
 - Weapons effects
 - Not as great as for marine-grade steel
- Risk of hull girder fracture
 - Fatigue crack propagation
 - Need means to arrest a growing crack

Fire Protection

- Aluminum has relatively low melting point
 - Must be insulated
 - Protect structure from softening or melting in shipboard fire
- Fire zone boundaries on commercial vessels required
 - International convention
 - Regulations of the U.S. Coast Guard
- Procedures for designing insulation to meet these requirements
 - Established in the 1970s by the Society of Naval Architects and Marine Engineers
 - Have not significantly advanced since that time
- Fire protection insulation in aluminum structure
 - Reduces the weight advantage of aluminum over steel
 - Adds to the price
 - Less expensive and lighter means of insulating aluminum are being sought

Vibration

- Aluminum has one-third the elastic modulus of steel
 - One-third the density
 - Similar structures in aluminum and steel have same natural frequency of vibration
 - Other mass associated with mode of vibration reduced frequency of aluminum more.
- Aluminum less tolerant of vibration
 - Stress concentrations in the vibrating structure
 - Points of fatigue crack initiation
- Hull girder vibration and local vibration of structural members
 - Classification societies impose minimum inertia requirements

Maintenance and Repair

- Excellent corrosion resistance of aluminum
 - No painting is required for many alloys
 - More than 30 years service without problems
 - Some alloys are more prone to corrosion and must be coated to protect them
- Painting of topside structure for cosmetic reasons
 - Coating has to be maintained
- Painting below the waterline with antifouling
- Sewage and gray water tanks coated
 - Corrosive nature of the fluids in these tanks
- Low fatigue resistance of aluminum
 - Structural cracking can become a maintenance headache
 - Improperly designed structure
 - Areas that crack redesigned with improved structural details
 - Prevent recurrence of the cracks in the same place

Mitigating Slam Loads

- High-speed craft
 - Large loads on the bottom structure from slamming into waves
 - Loads can cause local structural damage or damage to the hull girder
- Reduce these loads
 - Operate at reduced speeds
 - Take more favorable headings
- Ship's force often not able to perceive these damaging slams
 - Hull instrumentation required
- Classification societies provide special classification if instrumented
 - Usage is not well accepted.

Emerging Technologies

- Friction stir welding
 - Developed in the early 1990s
 - Used extensively today
 - Joining light-weight extruded panels
 - Size of extrusion dies limits the size of the panels produced
 - Extrusions shipped to a friction stir welding facility
 - Joined into panels of size that can be shipped over the road
 - More economical
 - Less distortion
- Inspection standards developed for friction stir welding
 - Testing required to confirm properties of the joints
 - Fatigue and corrosion resistance
 - Process lacks versatility today
 - Confined to materials that can be brought to the welding machines.

Chapter 2

Material Characteristics

Alloy and Temper Designations

- 5xxx-series
 - Magnesium is principal alloying agent
 - Many have a significant amount of manganese
 - Work hardening
 - Number followed by H and up to 3-digit number
 - H1 only strain hardened
 - H2 strain hardened and then slightly annealed
 - H3 strain hardened and then has the properties stabilized by either low-temperature treatment, or by heat introduced during fabrication
 - Example: 5083-H116
- 6xxx series
 - Magnesium and silicon as principal alloying agents
 - Heat-treatable
 - T and following number indicates type of heat treatment
 - T6 is most common
 - Example: 6061-T6

Chemical Composition of Aluminum Alloys (Percentage by Weight)

Alloy	Si	Fe	Cu	Mn	Mg	Cr	Zn	Ti
5059	0.45	0.50	0.25	0.60-1.2	5.0-6.0	0.25	0.40-0.90	0.20
5083	0.40	0.40	0.10	0.40-1.0	4.0-4.9	0.05-0.25	0.25	0.15
5086	0.40	0.50	0.10	0.20-0.70	3.5-4.5	0.05-0.25	0.25	0.15
5383	0.25	0.25	0.20	0.7-1.0	4.0-5.2	0.25	0.40	0.15
5454	0.25	0.40	0.10	0.50-1.00	2.4-3.0	0.05-0.20	0.25	0.20
5456	0.25	0.40	0.10	0.50-1.00	4.7-5.5	0.05-0.20	0.25	0.20
6005A	.50-.90	0.35	0.3	0.5	.40-.70	0.3	0.2	0.1
6061	.40-.80	0.7	.15-.40	0.15	.80-1.20	0.04-0.35	0.25	0.15
6063	0.20-0.60	0.35	0.10	0.10	0.45-0.90	0.10	0.10	0.10
6082	0.7-1.3	0.50	0.1	0.40-1.0	0.6-1.2	0.25	0.20	0.10

Mechanical Properties

- No defined yield point
 - Yield strength, or proof stress, is defined by a 0.2 percent offset of the engineering stress-strain curve from testing of a tensile specimen

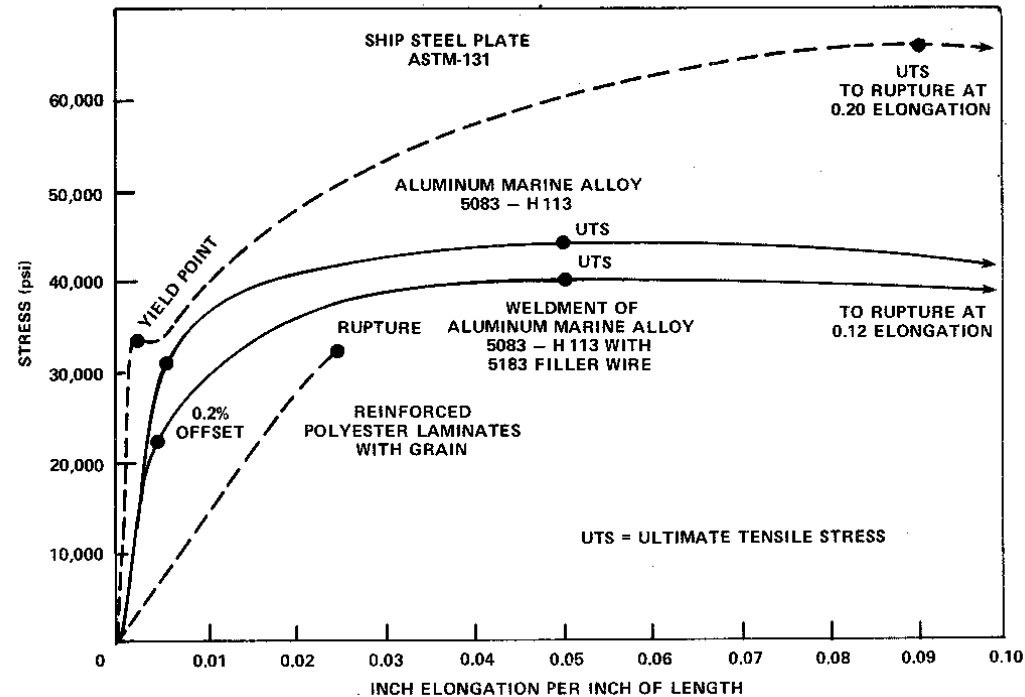

Stress-strain curve of 5083 aluminum compared to steel and FRP (Beach et al., 1984).

Mechanical Properties of Marine Aluminum Alloys

Alloy and Temper	Thickness Range		Ultimate Strength ⁵		Yield Strength ⁵ (0.2% Offset)		Elastic Modulus		Density	
	in	mm	ksi	MPa	ksi	MPa	ksi x10 ³	MPa x 10 ³	lbs/in ³	g/cm ³
5059-H111 (E) ¹	0.114-1.968	3.0-50	47.7	329	23.2	160			0.096	2.66
5059-H116 (S&P) ¹	0.114-0.787	3.0-20	53.5	438	39.1	270			0.096	2.66
5059-H116 (P) ¹	0.788-1.968	20.1-50	52.1	359	37.6	259				
5059-H321 (P) ¹	0.114-0.787	3.0-20	53.5	369	39.1	270				
5059-H321 (S&P) ¹	0.788-1.968	20.1-50	52.1	359	37.6	259				
5083-0										
5083-H111 (E)	<=5.0	<=130	40.0	275	24.0	165	10.3	71.0	0.096	2.66
5083-H116 (S&P)	0.188-1.5	4.0-40	44.0	305	31.0	215	10.3	71.0	0.096	2.66
5083-H116 (P)	1.5-3.0	40-80	41.0	285	29.0	200	10.3	71.0	0.096	2.66
5083-H321 (S&P) ¹	0.063-1.5	1.6-38	44.0	303	31.0	214				
5083-H321 (P) ¹	1.501-3.0	38.1-76.5	41.0	283	29.0	200				
5086-H111 (E)	<=5.0	<=130	36.0	250	21.0	145	10.3	71.0	0.096	2.66
5086-H116 (S&P)	All	All	40.0	275	28.0	195	10.3	71.0	0.096	2.66
5383-H-112 (E) ²			45.0	310	27.6	190	10.2	70.0	0.096	2.66
5383-H116 (P) ²	<0.79	<20	44.2	305	31.2	215	10.2	70.0	0.096	2.66
5383-H116 (P)										
5454-H111 (E)	<=5.0	<=130	33.0	230	19.0	130	10.3	71.0	0.097	2.69
5454-H32 (S&P)	0.02-2.0	0.5-50	36.0	250	26.0	180	10.3	71.0	0.097	2.69
5456-H116 (S&P)	0.188-1.25	4.0-12.5	46.0	315	33.0	230	10.3	71.0	0.096	2.66
5456-H116 (P)	1.251-1.5	12.51-0.0	44.0	305	31.0	215	10.3	71.0	0.096	2.66

Mechanical Properties of Marine Aluminum Alloys

Alloy and Temper	Thickness Range		Ultimate Strength ⁵		Yield Strength ⁵ (0.2% Offset)		Elastic Modulus		Density	
	in	mm	ksi	MPa	ksi	MPa	ksi x10 ³	MPa x 10 ³	lbs/in ³	g/cm ³
5456-H116 (P)	1.501-3.0	40.01-80	41.0	285	29.0	200	10.3	71.0	0.096	2.66
5456-H321 (S&P) ¹	0.188-0.499		46.0 59.0		33.0 46.0				0.096	2.66
6005A-T61 (E) ³			38.0	260	35.0	240	10.0	68.9	0.098	2.70
6061-T6 (E)	All	All	38.0	260	35.0	240	10.0	68.9	0.098	2.70
6063-T6 (E)	All	All	30.0	205	25.0	170	10.0	68.9	0.097	2.70
6082-T6 (E) ¹	All	All	45.0	310	38.0	262			0.098	2.70

(E) Extrusions, (S&P) Sheet and Plate, (P) Plate
Notes

1. ABS, Rules for Materials and Welding, 2006
2. ALCAN, 2004.
3. Data supplied by Tower Extrusions, Olney, Texas.
4. Aluminum Standards & Data – 2006
5. Where two values are given, the first is the minimum allowable, and the second is the maximum allowable.

Properties at Elevated Temperatures

- Aluminum does not burn in a shipboard fire
- It does melt

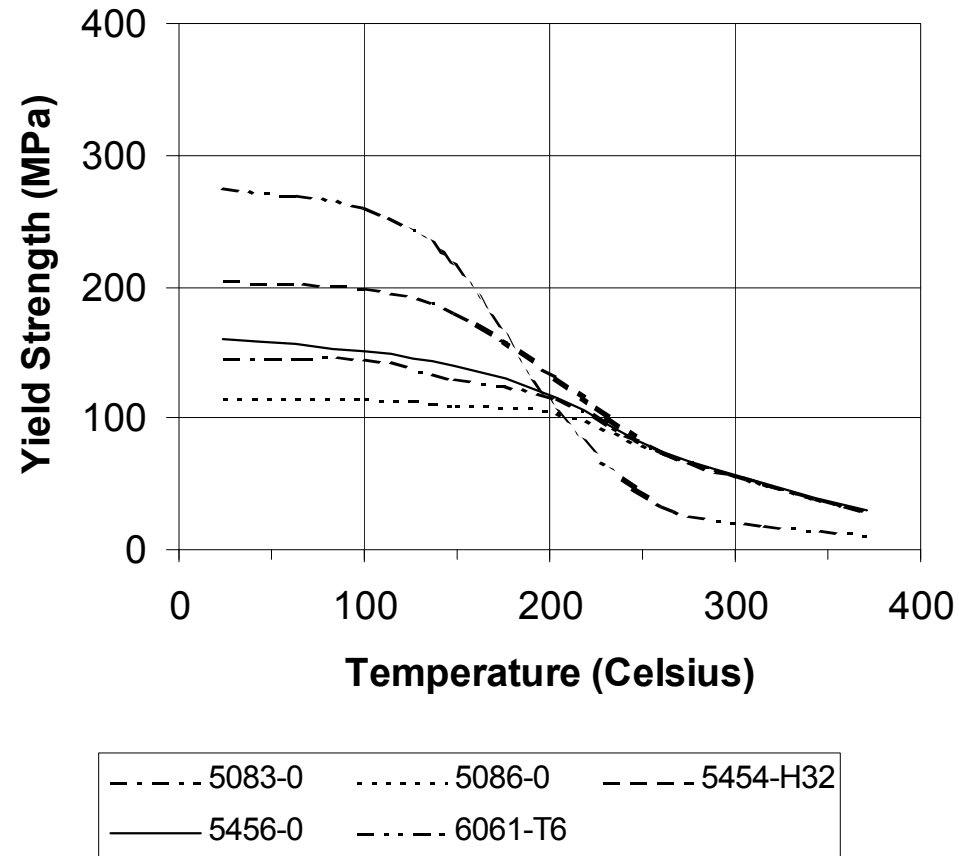

Reduction of yield strength with temperature (Aluminum Association, 2005).

Marine Aluminum Alloys

- **5xxx Series**

- Found to be best suited for marine use in the 1950s
- Marine service alloys and tempers listed in ASTM B 928-04 5059-H116
 - 5059-H321
 - 5083-H116
 - 5083-H321
 - 5086-H116
 - 5383-H116
 - 5383-H321
 - 5456-H116
 - 5456-H321
- Need not be B-928 if:
 - 5xxx alloys containing less than 3 percent Mg
 - Tempers not susceptible to sensitization
 - Annealed (-O temper)
 - 5454-H32
 - Magnesium range of 2.4 to 3.0 percent
 - Used where operating temperature is in excess of 65 °C (150 °F)

Marine Aluminum Alloys (Cont)

- **6xxx Series and Corrosion Resistance**
 - Generally considered to have poorer corrosion resistance than the 5xxx-series
 - Principal strengthening mechanism
 - Precipitates of magnesium silicide (Mg_2Si)
 - Formed within the aluminum matrix during the heat treatment and ageing process
 - Approximately the same galvanic electrical potential as the aluminum matrix
 - Don't contribute to galvanic corrosion
 - Possible problems if excess silicon
 - Casting alloys
 - Contain 0.10 to 1.0 percent copper
 - Copper precipitates cathodic to aluminum matrix
 - Localized corrosion of the aluminum
 - As the aluminum corrodes
 - Copper remains
 - Local copper concentration increases
 - Local corrosion rate increases

Marine Aluminum Alloys (Cont)

- **6xxx-series (Continued)**
 - International Association of Classification Societies
 - Requirements Concerning Materials and Welding
 - “The alloy grades 6005A, 6061 of the 6000 series should not be used in direct contact with sea water unless protected by anodes and/or paint system.”
 - Alloy 6061 — 0.15 to 0.40 percent copper
 - 6005A — 0.30 percent copper
 - 6082 alloy — 0.10 percent copper
 - No restriction on its use
 - No straight comparative data between 5xxx and 6xxx-series alloys

Welded Properties of Aluminum

- Marine aluminum alloys either
 - Work hardened (5xxx-series)
 - Heat treatment (6xxx-series)
- Annealing process can begin at 150 °C (300 °F)
 - Welding heat-affected zone (HAZ) this temperature and higher
 - Reduction in properties
 - 0-tempers in the annealed condition
 - Welding does not reduce their strength
- Testing is performed on butt weld
 - Tensile cut specimens that include the weld
 - Dog bone tensile specimen cut transverse to the weld
 - Standards
 - 50 mm (2 inches)
 - Weld and HAZ only
 - 250 mm (10 inches)
 - Base plate included

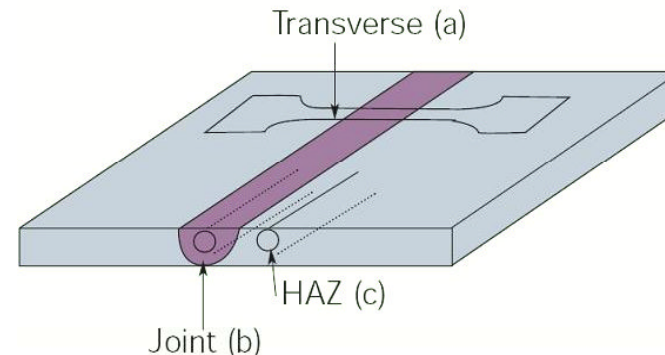

A transverse tensile specimen from a weld joint (ALCAN, 2004).

Yield Strength of Welded Aluminum Alloys (MPa, ksi)

Alloy	Type ¹	Source					
		ABS ²	DnV ³	Aluminum Association ⁴	AWS Hull Welding ⁵	ALCAN ⁶	US Navy ⁷
5086-H0	E		92 (13)	95 (14)			97 (14)
5086-H32	P	131 (19)	92	95 (14)	131 (19)		152 (22)
5086-H111	E	124 (18)	92	95 (14)	124 (18)		110 (16)
5086-H116	P	131 (19)	92	95 (14)	131 (19)		152 (22)
5083-H111	E	145 (21)		110 (16)	145 (21)		
5083-H116	P	165 (24)	116 ⁸ (17)	115 (18)	165 (24) ⁹	125 (18)	
5383-H111	E	145 (21)				145 (21)	
5383-H116	P	145 (21)	140 (20)			145 (21)	
5059-H111	E						
5059-H116	P						
5454-H111	E	110 (16)	76 (11)	85 (12)	110 (16)		110 (16)
5454-H34	P	110 (16)	76 (11)	85 (12)	110 (16)		110 (16)
5454-H32	P	110 (16)	76 (11)	85 (12)	110 (16)		
5456-H111	E	165 (24)			165 (24)		145 (21)
5456-H116	P	179 (26)		125 (19)	179 (26)		179 (26)
6061-T6 ¹⁰	E, P	138 (20)	105 (15)	105 (15)	138 (20)		
6061-T6	E, P	103 (15)	105 (15)	80 (11)	103 (15)		

Notes on Yield Strength of Welded Aluminum

1. E = Extrusion, P = Plate
2. Rules for Materials and Welding, Part 2, Aluminum and Fiber Reinforced Plastics, Chapter 5, Appendix 1, Table 2, American Bureau of Shipping
3. Det Norske Veritas, Rules for Classification of High Speed, Light Craft and Naval Surface Craft, Part 3, Chapter 3, Section 2, Table B4. Yield strength determined from the values of f_1 published by the equation $\sigma_1 = f_1 \times 240 / 1.1$.
4. Aluminum Design Manual, Table 3.3-2, The Aluminum Association, Arlington, Virginia. Based on 50 mm (2 in.) gauge length
5. Guide for Aluminum Hull Welding, AWS D3.7, American Welding Society, 2004. Based on 250 mm (10 in.) gauge length
6. Aluminium and the Sea, ALCAN, Paris, 2004.
7. A Guide for the Use of Aluminum Alloys in Naval Ship Construction and Design, Volume II, Table 4.1, David W. Taylor Naval Ship Research and Development Center, DTNSRDC 84/015, 1984.
8. Thickness ≤ 9.5 mm (0.275 in.)
9. Welded with 5356 filler.
10. 5083-H 321 Plate, thickness ≤ 38 mm (1.5 in.)

Corrosion

- Aluminum has very good corrosion resistance
 - Better than steel
 - Many unpainted vessels have operated for 30 years or more in seawater
 - Corrosion can occur in some conditions
- Types of corrosion
 1. General corrosion and pitting
 2. Exfoliation
 3. Intergranular corrosion
 4. Stress-corrosion cracking
 5. Corrosion-erosion, impingement, and cavitation
 6. Galvanic corrosion
 7. Crevice corrosion

Corrosion (Cont.)

- General Corrosion
 - Wastage of material over a broad area
 - Gray oxide film
 - Film provides corrosion resistance
 - Must remain stable and unbroken.
 - 5xxx-series corrode by general corrosion
 - Good resistance to it
 - 6xxx-series better resistance to general corrosion
 - Pitting
 - Small holes scattered over surface
 - 5xxx-series good resistance to pitting
 - 6xxx-series not as good

Corrosion (Cont.)

- Exfoliation
 - 5xxx series with magnesium ≥ 3.0 percent
 - Corrosion along planes parallel to the surface, gives layered appearance
 - ASTM B 928 covers the H116 and H321 tempers
 - Requires ASTM G 66 (ASSET) test
 - Used to provide visual assessment of exfoliation corrosion susceptibility.
 - Temper H116 developed in 1970s to correct problem
 - No specifications for testing 5xxx series extrusions for exfoliation



Example of exfoliation on the edge of a waterway bar (Dye and Dawson, 1974).

Corrosion (Cont.)

- Intergranular Corrosion
 - 5xxx series with magnesium ≥ 3.0 percent
 - Precipitation of magnesium to grain boundaries
 - ASTM B 928 covers the H116 and H321 tempers
 - Requires ASTM G 67 (NAML T) test
 - No specifications for testing 5xxx series extrusions for intergranular corrosion



An example of intergranular corrosion (Bushfield et al., 2003).

Corrosion (Cont.)

- Stress-Corrosion Cracking
 - Sustained tensile surface stress (external or residual) in a corrosive environment
 - Electrochemical and mechanical processes
 - Local cell action creates a sharp pit
 - Induces mechanical tearing at the root
 - Exposes fresh metal surface to accelerated corrosion
 - Further corrosion deepens the crack and continues the process
 - Characterized by intergranular cracks normal to the metal surface and stress direction
 - Processes same as intergranular corrosion
 - 5xxx-series and 6xxx-series alloys resistant to stress-corrosion cracking
 - When higher magnesium 5xxx-series alloys become sensitized
 - Stress-corrosion cracking can result.

Corrosion (Cont.)

- Corrosion-Erosion, Impingement, and Cavitation
 - Corrosion-erosion from continuous disruption of oxide film
 - High velocity fluid flow
 - Resistance sensitive to differences in seawater velocity and temperature
 - Impingement attack from a stream of liquid striking a surface
 - Accelerated by air bubbles in liquid
 - Cavitation erosion
 - Collapse of voids at high speed
 - Harder alloys have better resistance
 - Aluminum alloys in general have very poor cavitation erosion.

Corrosion (Cont.)

- Galvanic Corrosion
 - Two dissimilar metals coupled in an electrolyte
 - Positive electrical potential — cathode
 - Lower electrical potential — anode
 - Cathode attacks anode
 - Anode can protect and prevent the corrosion of the cathode
 - Aluminum alloys have different potential
 - Use alloys with same potential together
 - Relative areas of the two metals influences the corrosion rate
 - Scratch in paint on aluminum will corrode rapidly if cathode nearby
 - Cathodic metals used in propulsion train
 - Brass, bronze and Monel used for shafting and propellers
 - Passive protection system
 - Zinc anodes attached to studs on the hull
 - Active impressed current system
 - Titanium anodes
 - Surface mounted
 - Mounted in a recess in the hull
 - DC current imposed

**Solution Potential of Aluminum Alloys and Other Metals Based on ASTM G69
Corrosion of Aluminum and Aluminum Alloys, J. R. Davis, ASM
International, 1999**

Metal or Alloy	Lower Limit	E_{corr}, V	Upper Limit
Mg		-1.64	
Zn	-1.01	-0.98	
7003		-0.94	
7002, Alclad 3003, Alclad 6061, Alclad 7075		-0.87	
7039-T6, T63, 7005	-0.87	-0.84	
5056, 7079-T6, 5456, 5083, 5182		-.078	
5154, 5454, 5254, 5042		-0.77	
5052, 5086, Alclad 2024, Alclad 2014		-0.76	
3004, 1060, 5050		-0.75	
7055-T77		-0.75	-0.74
7075-T7, 8090-T7, 7049-T7, 7050-T7, 7475-T7	-.077	-0.75	-0.73
Al (99.999%)	-0.76	-0.75	-0.73
5030-T4, 2090-T8		-.074	
3003, 1100, 6061-T6, 6053, 6063		-0.74	
7075-T6, 7178-T6	-0.76	-0.74	-0.72
6013-T6, T8	-0.74	-0.73	
6061-T4, 6009-T4		-0.71	
2024-T8	-0.73	-0.71	
2219-T6, T8	-0.73	-0.71	-0.70
2008-T6	-0.74	-0.71	-0.70
Pb		-0.71	-0.45
8090-T3, 6010-T4		-0.70	
2014-T6, 2008-T4		-0.69	

**Solution Potential of Aluminum Alloys and Other Metals Based on ASTM G69
Corrosion of Aluminum and Aluminum Alloys, J. R. Davis, ASM
International, 1999**

Metal or Alloy	Lower Limit	E_{corr}, V	Upper Limit
2091-T3, T8	-0.76	-0.67	-0.66
Ti (99.7%)		-0.66	+0.14
2036-T6, 2090-T3, 4		-0.65	
2036-T3, T4		-0.64	-0.63
2324-T39		-0.62	
2014-T4, 2017-T4, 2024-T3, T4	-0.62	-0.60	-0.59
2219-T3, T4	-0.56	-0.55	-0.54
Fe	-0.60		-0.49
Stainless Steel 321	-0.31	-0.30	-0.25
Monel 400 (Ni65, Cu33, Fe2)	-0.43		-0.25
Mn	-0.80		-0.40
Zr (99.9%)	-0.20		+0.02
Sn (99.99%)	-0.40		-0.19
Brass (Cu63, Zn37)	-0.30		-0.08
Ti-6Al-4V	-0.05		+0.27
Bronze (Cu94, Sn6)	-0.08		-0.02
Cu (99.999%)	-0.11	+0.00	+0.08
Stainless Steel 316	-0.70		+0.27
Ni 270		+0.12	
Cr (99.9%)		+0.23	+0.32

Corrosion (Cont.)

- Crevice Corrosion
 - Similar to galvanic corrosion
 - Caused by a difference in electrical potential
 - Greater concentration of the electrolytes in different areas of the solution
 - Lapped joints in riveted construction
 - Dissimilar metals can accelerate the tendency for crevice corrosion

Product Forms

- Flat plate
 - Thickness < 0.25 inches (6 mm) thick — sheet
 - Thickness ≥ 0.25 inches (6 mm) thick — plate
- Forgings
- Castings
- Extrusions
 - Hydraulic press
 - Forces heated (still-solid, but malleable) aluminum alloy through a steel die
 - Standard structural shapes
 - Tees, angles, flat bars, bulb flats and bulb tees
 - Special extrusion dies cost little
 - \$800 – \$30,000

Product Forms—Extrusions

SNAME Tee Sections

Shape Designation	Total depth (in)	t_{web} (in)	Flange width (in)	t_{flange} (in)	Fillet radius (in)	Weight (lbs/ft)	Properties with 8.75" 0.25" plate		
							I (in ⁴)	SM _f (in ³)	r (in)
3 x 1.5 T	3.0	0.188	3.0	0.257	0.282	1.5	5.7	2.54	1.28
4 x 2.0 T	4.0	0.188	4.0	0.254	0.282	2.0	12.4	4.57	1.78
5 x 2.5 T	5.0	0.188	4.5	0.282	0.282	2.5	22.0	6.99	2.25
6 x 3.0 T	6.0	0.219	4.5	0.291	0.329	3.0	33.8	9.23	2.65
7 x 3.5 T	7.0	0.255	4.75	0.312	0.338	3.5	49.7	12.17	3.08
8 x 4.0 T	8.0	0.258	4.75	0.300	0.387	4.0	66.8	14.43	3.32
8 x 4.5 T	8.0	0.258	4.75	0.397	0.387	4.5	74.0	17.10	3.49
8 x 5.0 T	8.0	0.277	4.75	0.459	0.416	5.0	79.0	18.98	3.48
10 x 5.75 T	10.0	0.324	5.0	0.352	0.486	5.75	124.0	23.00	4.16
10 x 6.5 T	10.0	0.324	5.0	0.492	0.486	6.5	138.5	26.28	4.21
10 x 7.25 T	10.0	0.349	5.0	0.578	0.524	7.25	148.0	27.01	4.18
12 x 8.0 T	12.0	0.391	5.0	0.457	0.587	8.0	213.7	34.42	4.83
12 x 9.0 T	12.0	0.391	5.0	0.645	0.587	9.0	237.0	35.48	4.87
12 x 10.0 T	12.0	0.430	5.0	0.732	0.645	10.0	250.8	36.72	4.81

Product Forms—Extrusions (Cont)

SNAME Angle Sections

Shape Designation	Total depth (in)	t_{web} (in)	Flange width (in)	t_{flange} (in)	Fillet radius (in)	Weight (lbs/ft)	Properties with 8.75" 0.25" plate		
							I (in ⁴)	SM_f (in ³)	r (in)
3 x 1.58 L	3.0	0.188	3.0	0.281	0.282	1.58	6.0	2.73	1.30
4 x 1.90 L	4.0	0.188	3.0	0.313	0.282	1.90	11.6	4.16	1.74
5 x 2.41 L	5.0	0.188	3.5	0.344	0.282	2.41	21.1	6.57	2.22
6 x 2.97 L	6.0	0.188	4.0	0.375	0.282	2.97	34.5	9.65	2.70
7 x 3.95 L	7.0	0.218	4.5	0.438	0.327	3.95	54.9	14.42	3.12
8 x 5.07 L	8.0	0.250	5.0	0.500	0.375	5.07	81.6	19.21	3.51
9 x 6.15 L	9.0	0.281	5.5	0.531	0.422	6.15	113.7	22.82	3.88

Product Forms—Extrusions (Cont.)

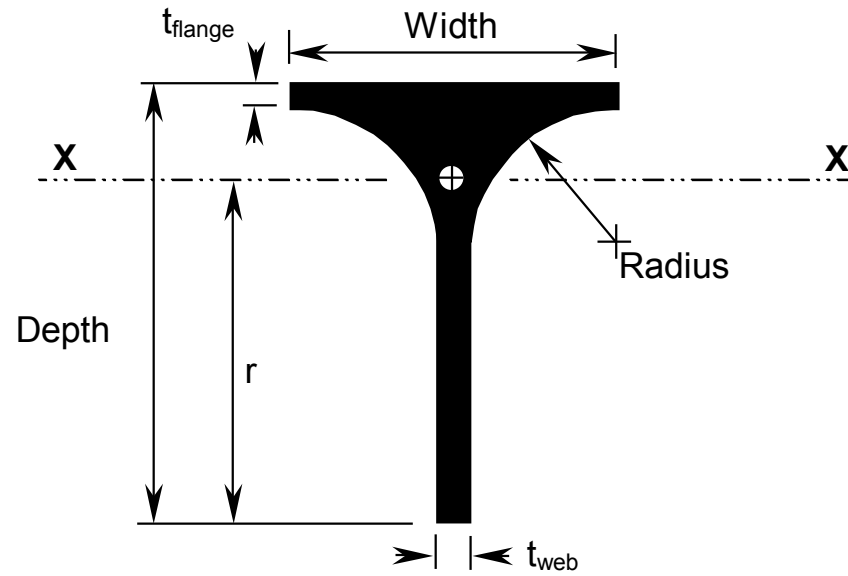

Rounded tee profile.

Product Forms—Extrusions (Cont.)

Properties of Rounded Tees

Depth (mm)/ (in)	Width (mm)/ (in)	t _{flange} (mm) (in)	t _{web} (mm)/ (in)	Radius (mm)/ (in)	Area (mm ²)/ (in ²)	Weight (kg/m)/ (lb/ft)	Centroid height (mm) (in)	I _{xx} about centroid (mm ⁴)(in ⁴)	I _{yy} (mm ⁴)/ (in ⁴)
60 2.362	40 1.575	3 0.118	3.5 0.138	18.25 0.719	462 0.716	1.249 0.839	43.83 1.726	140,309 0.337	22,647 0.054
70 2.756	40 1.575	3 0.118	4 0.157	18 0.709	527 0.817	1.423 0.956	49.25 1.939	239,089 0.574	22,899 0.055
80 3.150	40 1.575	3 0.118	4.5 0.177	17.75 0.699	602 0.933	1.625 1.092	54.24 2.135	377,028 0.906	23,222 0.056
90 3.543	90 3.543	6 0.236	8 0.315	27 1.063	1,525 2.364	4.117 2.767	65.32 2.572	1,074,098 2.581	507,579 1.219
100 3.937	50 1.969	3 0.118	5.5 0.217	22.25 0.876	896 1.389	2.419 1.625	67.19 2.645	886,635 2.130	48,825 0.117
120 4.724	50 1.969	3 0.118	6.5 0.256	21.75 0.856	1,114 1.727	3.007 2.021	76.36 3.006	1,639,940 3.940	50,523 0.121
140 5.512	50 1.969	4 0.157	7.5 0.295	21.25 0.837	1,414 2.192	3.817 2.565	86.57 3.408	2,843,222 6.831	63,386 0.152
180 7.087	60 2.362	4 0.157	8 0.315	28 1.102	1,984 3.075	5.358 3.600	112.75 4.439	6,621,525 15.908	6,476,987 15.561
181.1 7.130	70.6 2.780	10.2 0.402	7.2 0.283	30 1.181	2,337 3.622	6.31 4.240	126.37 4.975	7,400,243 17.779	7,397,998 17.774

Product Forms—Extrusions (Cont.)

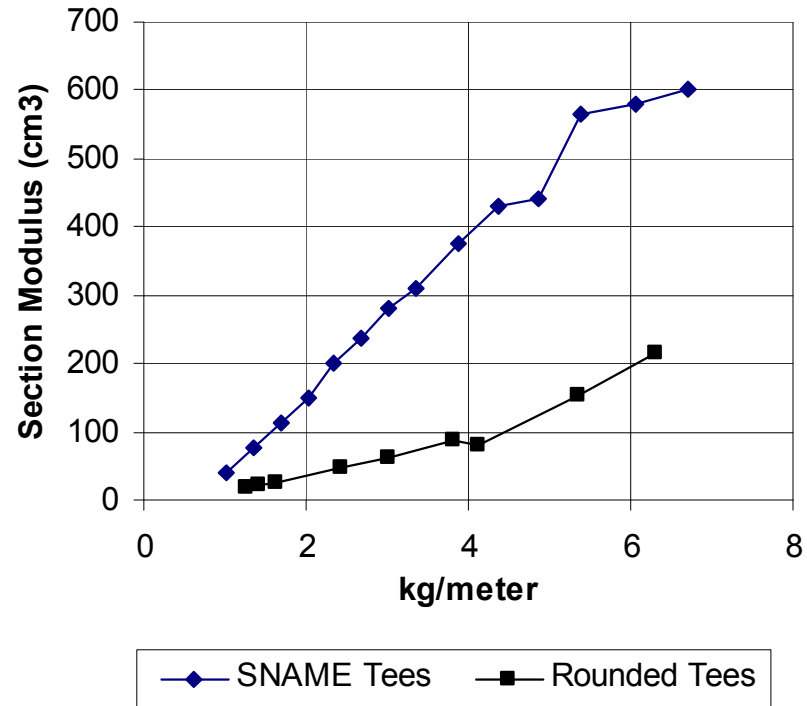

Comparison of section moduli of rounded tees with conventional tees.

Product Forms—Extrusions (Cont.)



Bulb flat.

Properties of Bulb Flats

Depth (mm)/ (in)	Width (mm)/ (in)	d_{flange} (mm)/ (in)	t_{web} (mm)/ (in)	Tip radius (mm)/ (in)	Area (mm ²)/ (in ²)	Weight (kg/m)/ (lb/ft)	Centroid height (mm)/ (in)	I _{xx} about centroid (mm ⁴)/ (in ⁴)	I _{yy} (mm ⁴)/ (in ⁴)
50.0 1.969	14.0 0.551	8.0	4.5	2.5	280 0.435	0.757 0.508	29.31 1.15	68,243 0.1640	2,544 0.0061
50.0 1.969	15.0 0.591	6.2	5.0	2.0	297 0.461	0.802 0.539	28.56 1.12	72,227 0.1737	2,783 0.0067
76.2 3.00	19.05 0.75	10.72	5.38	3.18	515 0.799	1.392 0.935	45.04 1.77	295,531 0.7100	8,672 0.0208
76.2 3.00	21.0 0.827	10.9	5.0	3.0	505 0.783	1.363 0.916	46.43 1.83	292,736 0.7034	11,460 0.0275
98.7 3.866	19.05 0.75	10.72	5.35	3.18	634 0.978	1.711 1.144	56.88 2.23	609,035 1.4424	9,272 0.0223

Product Forms—Extrusions (Cont.)

- **Limitations in Extrusion Thickness**
 - 5086 thickness ≥ 3.3 mm (0.128 inches) thick
 - 5083 thickness ≥ 4.6 mm (0.18 inches)
 - Hollow extrusions cannot be made in the 5xxx-series
 - Unless the wall thickness is very great
 - 6xxx-series thickness ≥ 2 -mm (0.08-inch)
 - 6xxx-series extrude 4 times faster than 5xxx-series in same shape

Product Forms—Extrusions (Cont.)

- A multitude of extrusion are available
- Designing a special-purpose extrusion is relative low-cost

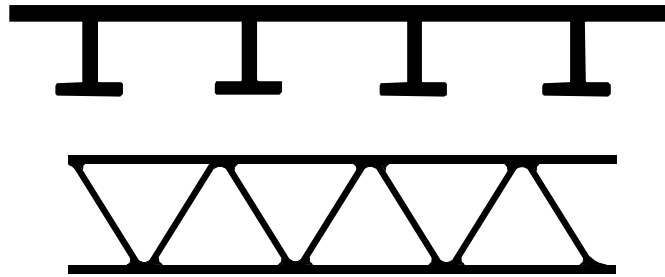

Integrally-Stiffened Panel Extrusions

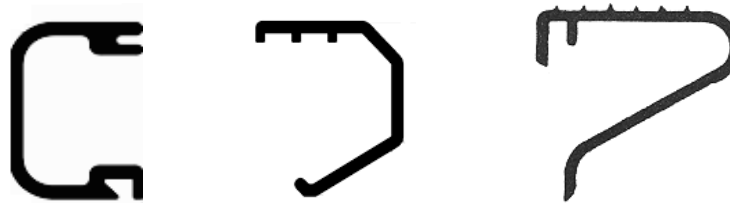

Special extrusions for gunwale.

Chapter 3

Structural Design

Design Guides, Rules, and Specifications

- ABS HSC Guide: Guide for Building and Classing High-Speed Craft, American Bureau of Shipping, October 2001.
- ABS HSNC: Guide for Building and Classing High Speed Naval Craft, American Bureau of Shipping, 2003.
- DNV: Rules for Classification of High Speed, Light Craft and Naval Surface Craft, Det Norske Veritas, July, 2000.
- U.S. Navy
 - Structural Design Manual for Surface Ships, (NAVSEA, 1976)
 - General Specifications for Design and Construction of US Navy Ships
 - Design Data Sheets
 - Specifications for specific ships

The Structural Design Triangle

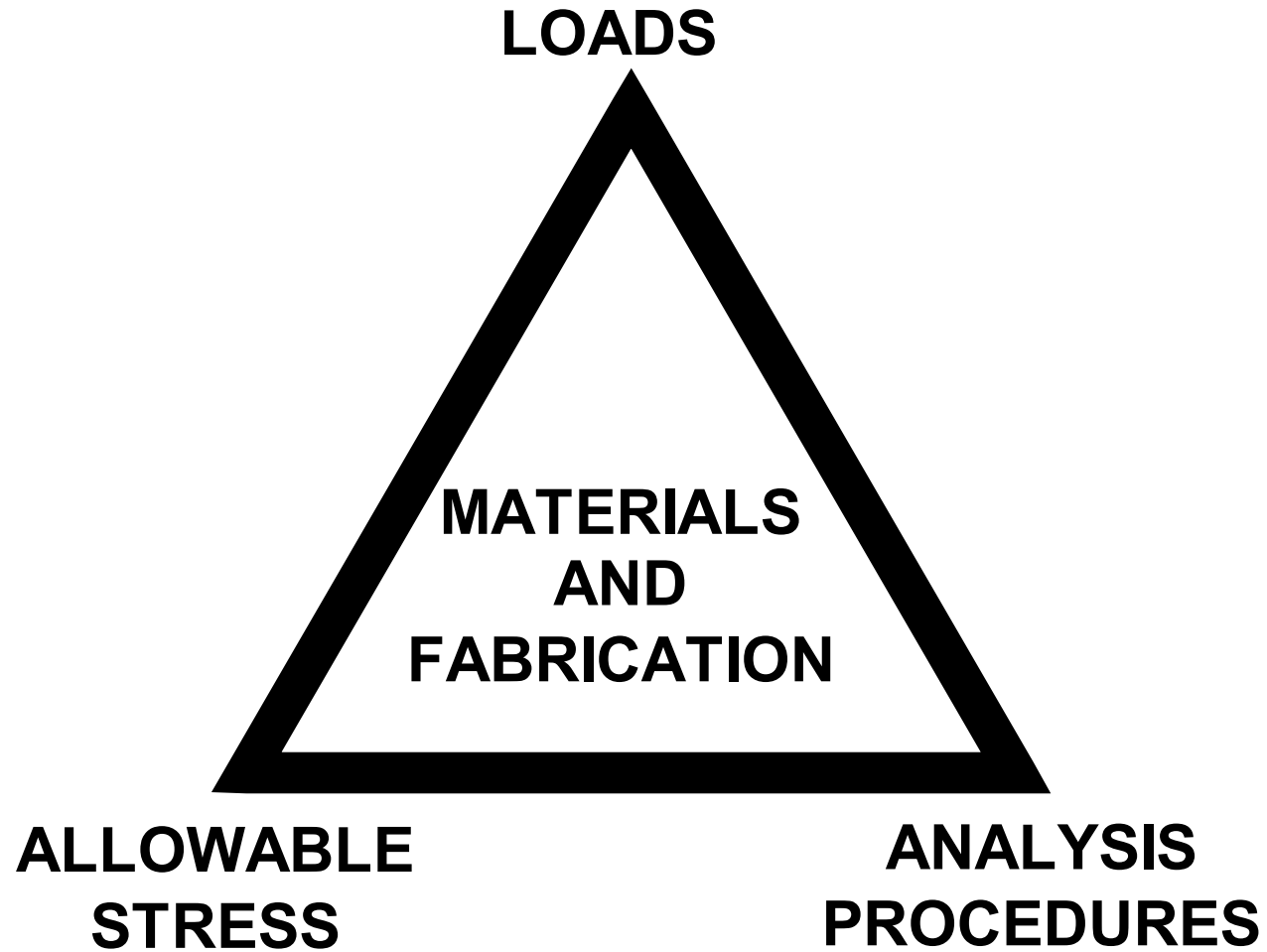

Reliability-Based Structural Design

- Reliability analysis methods
 - Tool for ensuring consistency between different design criteria
 - Equal reliability exists for similar steel and aluminum vessels
- No formal procedures implement direct reliability principles in design
 - Emphasis on partial safety factor design
 - Load and resistance factor design
- ABS developing LRFD rules for steel ships
- The Aluminum Association
- Aluminum Design Manual
 - Civil aluminum structures
 - Conventional allowable stress design
 - Load and resistance factor design specifications
- Until reliability-based design procedures are formally developed
 - Exercise caution in using so-called first-principles design methods
 - Factors of safety are present
 - Even if not implicitly specified in the design criteria

Structural Loads

U.S. Navy's Structural Design Manual for Surface Ships (NAVSEA, 1976)

1. Basic Loads

- a. Standard Live Loads
- b. Dead Loads
- c. Liquid/Tank loads
- d. Equipment and Cargo Loads

2. Sea Environment

- a. Hull Girder Loads
- b. Sea Loads
- c. Weather Loads
- d. Ship Motion Loads

3. Operational Environment

- a. Slamming
- b. Flooding
- c. Aircraft Landing
- d. Tank Overfill
- e. Docking
- f. Underway Replenishment

4. Combat Environment

- a. Shock
- b. Airblast
- c. Fragments
- d. Gun Blast and Reaction
- e. Missile Blast and Accidental Ignition

Hull Girder Bending

- Hydrostatic balance
 - \sqrt{L} , feet, ($0.606 \sqrt{L}$, meters) standard trochoidal wave
 - Replaced by more advanced methods today
 - Seriously underestimate the maximum lifetime moments by about 80 percent
 - U.S. Navy aluminum ships
 - Allowable design stress for hull girder bending 3.5 tons per square inch (54 MPa)
 - Nominal design stress
- Other Methods
 - Address actual ocean operating environment
 - Effect of ship heading relative to the waves
 - Torsional and transverse bending moments
 - Maximum lifetime loads.

Hull Girder Bending (Cont.)

- Model testing
 - Instrument actual ships or models of ships
 - Measure hull girder bending moments in waves,
 - At sea or in a wave tank.
- Instrumentation of actual ships
 - Costly and time consuming
 - Several years of data are required to obtain a realistic statistical database
 - Limited trials can be run with a wave buoy
 - Only estimate amplitude of waves
 - On-board wave height meters
 - Not successful to date
 - Instrumenting a ship invites calm weather
 - Generally not feasible option for ship design
 - Testing done on a prototype
 - Means of validating mathematical analysis methodologies
 - Advanced hull concepts used for many aluminum vessels
- Permanently installed strain gauging
 - Determining and reducing maximum hull girder loading
 - Information from installed systems
 - Valuable research tool if done right

Hull Girder Bending (Cont.)

- Instrumentation of models in a wave tank
 - Segmented model
 - Solid segments joined by a structural beam or spline
 - Model mass-stiffness for first modes of vibration
 - Models for multi-hulled craft can be similarly constructed
 - Rigid vinyl or other elastomer models to match actual ship structure
 - Some structural members modeled
 - Transverse bulkheads
 - Frames
 - Longitudinal structure
 - Instrumented with strain gages
 - Response scaled for difference in stiffness between elastomer and hull material
 - Can measure slam loading on structural panels
- Methods of wave tank testing
 - Test at constant wave frequencies
 - Transfer functions (RAOs) for range of ship headings and speeds
 - Series of sea spectra in wave tank
 - Represent most severe seas that the vessel is likely to encounter
 - Account for response associated with high waves and large ship motions
 - Extrapolate short-term statistics to determine maximum lifetime response
 - Combination of both
 - Test in irregular waves, use Fourier transformation to obtain RAOs

Mathematical Modeling

- Seakeeping programs
 - Determine pressures on the hull and their integrated responses of shear forces and bending moment
 - Strip-theory method, developed in the 1960s
 - Original method series of typical U-shaped or V-shaped forms for sections of hull along its length
 - Finite difference methods to accurately account for the effect of hull form on response
 - Model the response of catamarans, trimarans, and other unusual hull forms
 - Linear seakeeping programs
 - Compute response to unit wave heights
 - Generate RAOs very quickly
 - Can be used directly or with RAOs to simulate time-history response

Mathematical Modeling

- Nonlinear seakeeping programs
 - Compute the response in high waves and at high ship speeds
 - Not efficient to use in a design environment
 - Computer time significantly greater than the real time simulated
 - Use is costly for use in the ship design process
 - May require more time than available
- Programs that are not fully nonlinear
 - Can simulate ship response in a relatively short time with a fair degree of accuracy.
- International Ship and Offshore Structures Congress study
 - Comparative analysis of same vessel by various authorities
 - Failed to obtain the same results.

Design Formulas for Loads

- International Association of Classification Societies (IACS)
 - Formulas for large steel vessels
 - Maximum hull girder moments for design
 - Minimum values of hull girder section modulus
 - Requirements contained in rules of all member societies
- High-speed craft, including aluminum vessels
 - Different rules between classification societies
 - Hull girder bending moments and shears
 - Required midship section modulus
 - Minimum hull girder inertia
 - In most cases the final values must be validated through model tests, hydrodynamic analysis, or testing of similar vessel.
- Load Algorithms
 - Graphs for global loads on catamarans, trimarans and surface effect ships
 - Function of speed, heading wave frequency, and ship length and beam (Sikora and Klontz, 2005)
 - Based on experimental data
 - Show a great amount of scatter
 - Not compared to classification society rules or to seakeeping programs

Comparison of Requirements of ABS HSC and DNV High Speed Light Craft (Stone and Novak, 2006)

	ABS	Rule Acceleration		ABS Acceleration	
		DNV Cargo R_0	DNV Patrol R_0	DNV Cargo R_0	DNV Patrol R_0
Acceleration at CG, g's	2.42	1.69	2.95	2.42	2.42
Hull Girder Section Modulus, cm^2m	9,460	9,581	12,286	11,200	11,200
Design Pressure, Bottom Plating and Stiffeners at CG, kN/m^2	322	345.1	603.9	495	495
Thickness, Bottom Plating at CG, mm	8.56	8.11	10.73	9.71	9.71
Section Modulus, Bottom Stiffeners at CG, cm^2	48.1	35.7	62.4	51.2	51.2

Slamming Pressures

- Pressure distribution on surface not uniform
 - Peak pressures over very small area
- Difficult to record during instrumented trials of models or full-scale vessels
- Complex, difficult to mathematically model
 - Seakeeping programs difficult and expensive to implement
- Different structural items have different design pressures
 - Plating receives peak or near-peak pressure
 - Supporting grillage lower average pressure

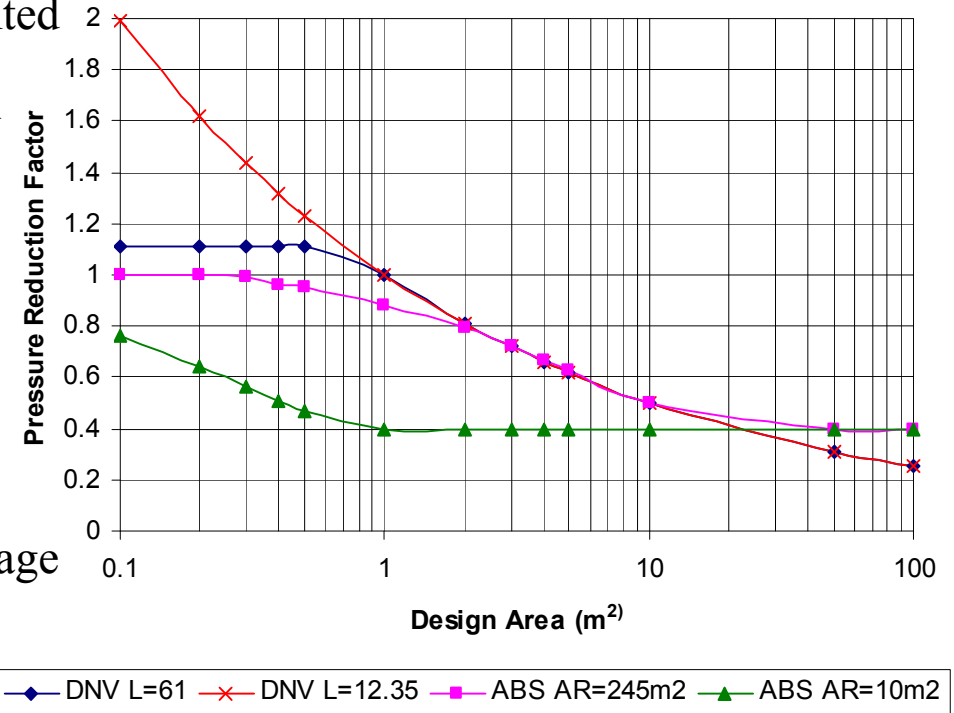

**Comparison of ABS and DNV
slam pressure reduction factors**

Allowable Stress Levels for Bottom Plating

Location	ABS HSC	ABS HSNC	DNV HSLC
Bottom Slamming	$0.90 \sigma_Y$	$0.90 \sigma_Y$	$200 f_1 = 178$
Bottom Slamming outside 0.4L		σ_Y	
Bottom Hydrostatic Pressure	$0.40 \sigma_Y$	$0.55 \sigma_Y$	$180 f_1 = 160.2$
Side Slamming	$0.90 \sigma_Y$	$0.90 \sigma_Y$	
Side Hydrostatic Pressure	$0.50 \sigma_Y$	$0.55 \sigma_Y$	$180 f_1 = 160.2$

- For design, must take pressure consistent with classification society rules
- Impractical to measure from model tests
 - Likely to miss peak pressure
 - Possible with structural grillage as part of model
- Model test or analyze to obtain accelerations
 - Use rule formula for pressure based on acceleration

Hydrostatic Pressures

- Pressures on shell from effective head of water treated as static
 - Variation with time slower than periods of response of structure
 - Distance to waterline plus add additional distance for dynamic and other effects
- US Navy combatant ships
 - Design head to the waterline plus $0.372 \sqrt{L}$ in meters ($0.675 \sqrt{L}$ in feet)
 - Head to waterline with ship heeled at angle, 35 degrees for smaller ships
 - Line between waterline amidships and a point 12 feet above the weather deck at FP
 - Nominal loads, used with allowable stresses that include inherent factors of safety
- ABS HSC Guide
 - Head to the waterline plus $0.0172 L + 3.653$ meters ($0.0172 L + 11.98$ feet)
 - Additional head multiplied by factor ranging between 0.5 for the most restricted service to 1.0 for unrestricted service.
 - ABS HSNC Rules factor for service conditions is 0.64.
 - DNV HSLC Rules, additional head equal to $(k_s - 0.15 h_0 / T) C_W$
 - k_s varies from $0.5 / C_B$ at the forward perpendicular to 0.75 at midships and further aft.
 - ABS and DNV loads maximum lifetime loads
- If other basis such as seakeeping analysis
 - Use with classification society rules

Structural Analysis Procedures

- Second leg of the design triangle
- Frames and Stiffeners
 - Historic rule-based procedures calculate stresses as accurately as possible

$$m = wl^2/k$$

w = load per unit length , l = span of the stiffener

k = factor for end fixity = 12 for fixed ends

- ABS HSC Guide, the ABS HSNV Rules and in the ABS guide for motor yachts

$$SM = \frac{144psl^2}{\sigma_a} \quad (\text{in}^3)$$

p = design pressure (psi), s = stiffener spacing in (feet)

l = stiffener span (feet), σ_a = allowable stress (psi)

$$144 = 12^3 / 12$$

- Only factor of safety introduced is in the allowable stress
 - Exact solution if all of assumptions on end fixity and load distribution met
 - Not always the case
 - Span defined as length to some point along an end bracket
 - Loads are not always uniform, and some averaging is required
- Finite element analysis is direct substitution for design equation

Effective Plating

- Shear lag
 - Transition from points of zero stress along the stiffener in bending
 - Will vary with end conditions and loading
 - Timoshenko (1956)

$$\frac{b_e}{s} = \frac{1.1}{1 + 2\left(\frac{s}{CL}\right)^2}$$

b_e = the effective breadth of plating
 s = stiffener spacing
 CL = the distance between points of zero stress.

- b_e / l usually taken as 1/3

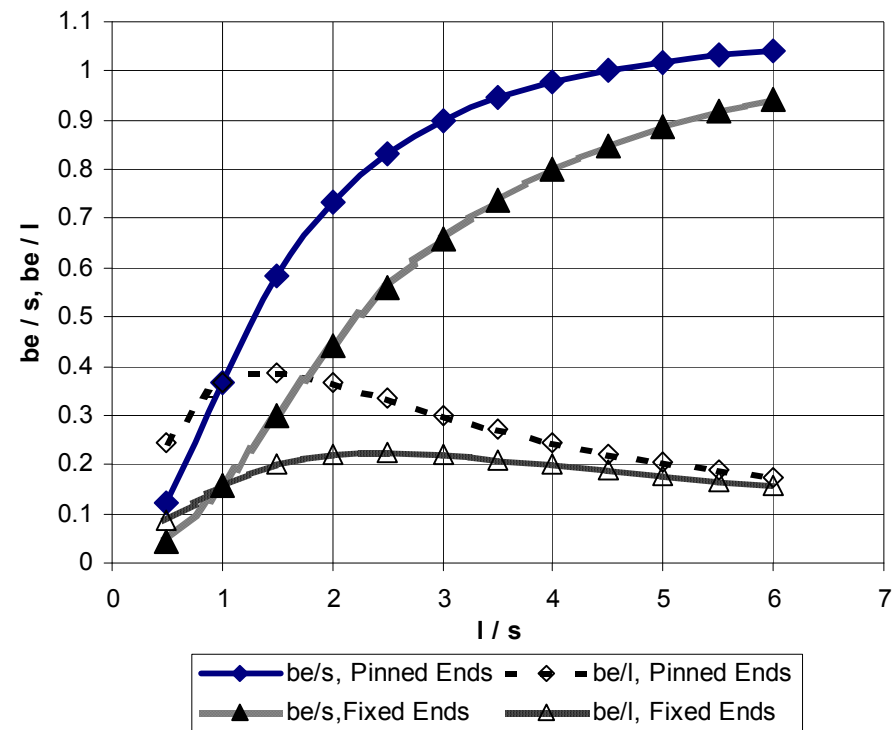

Effective Plating Reduction for Plate Buckling

- von Kármán:

$$\frac{b_e}{t} = \pi \sqrt{\frac{E}{3(1-\nu^2)\sigma_y}}$$

- ν = Poison ratio
 - if $\nu = 0.3$:

$$\frac{b_e}{t} = 1.9 \sqrt{\frac{E}{\sigma_y}}$$

U.S. Navy rounds coefficient to 2.0

Effective Width of Plate based on Buckling Strength

Alloy	Base Metal		Welded Properties	
	Yield Strength (MPa)	b_e/t	Yield Strength (MPa)	b_e/t
5083-H116	215	36	165	41
5086-H116	195	38	152	43
5383-H116	215	36	145	44
5456-H116	230	35	179	40

Analysis of Plating under Lateral Load

- Welded plating is continuous over stiffeners
 - Plate with continuous lateral pressure loading becomes fixed at the edges
 - Continuity permits in-plane membrane stresses
 - Membrane stresses very important if plastic deformation is permitted
 - Less deformation permitted in plating in the hull girder
- Linear elastic analysis based on classic plate theory seriously overestimate stresses in plating
- Strip of unit width plate of infinite aspect ratio clamped edges
 - Loaded by uniform pressure

$$M = pb^2/12$$

$$SM = t^2/6$$

$$\sigma = M/SM = pb^2/2t^2$$

$$t = s\sqrt{\frac{0.5p}{\sigma}}$$

- This equation used by ABS and DnV

Analysis of Plating under Lateral Load

- ABS HSC and HSNC

$$t = s \sqrt{\frac{p k}{1000 \sigma_a}}$$

t = required thickness in mm, s = stiffener spacing in mm

σ_a = design stress = 0.9 σ_0 for bottom plating with slamming pressure

σ_0 = welded yield strength of aluminum in MPa (N/mm²)

p = design pressure in kN/m²

k = factor based on panel aspect ratio = 0.5 for $l/s > 2.0$, = 0.308 for $l/s = 1.0$.

- DNV

$$t = s \sqrt{\frac{C p}{\sigma}}$$

t = required thickness in mm, s = stiffener spacing in m

p = design pressure in kN/m², σ = allowable stress in MPa (N/mm²)

C = coefficient that depends on edge conditions and aspect ratio of plate

For a plate panel with aspect ratio $l/s \geq 2.0$ and fixed edges, C = 500

for $l/s = 1.0$ and fixed edges, C = 310

Analysis of Plating under Lateral Load (Cont.)

- US Navy

$$\frac{s}{t} \leq \frac{C}{k\sqrt{h}}$$

k dependant on the aspect ratio of the plate panel

h is the design head of water in feet

C based on material and permanent set permitted

Values of Coefficient C to be used in U.S. Navy Equation for Plating

Alloy	σ_y (w) (ksi)	σ_u (bm) (ksi)	σ_b^3 (ksi)	Calculated C Values		
				No Set ⁴	Some Set ⁵	More Set ⁶
5083-H116	24.0 ⁶	44.0	19.8	298	467	597
5086-H116	22.0	40.0	18.0	285	445	569
5383-H116	21.0 ⁷	44.2	18.6	289	468	598
5456-H116	26.0	46.0	21.0	308	477	610
6005A-T61	16.7 ⁹	38.0	15.5	264	434	555
6061-T6	15.0	38.0	14.8	258	434	555
6063-T6	9.4 ⁹	30.0	10.7	220	385	493
6082-T6	16.7 ⁹	45.0	17.1	277	472	604

Comparison of Requirements for the Bottom Plating of a 61-meter, 50-Knot Craft

Design Method	Design Pressure (kN/m ²)	Required plate Thickness (mm)
ABS HSC Guide	363	9.09
ABS HSNC Rules	322	8.56
DNV HSLC Rules, Patrol Vessel R0	604	10.73
US Navy Specifications	56	2.39

5083-H116 plates for an 800 mm x 260 mm panel of bottom plating of a 61-meter, 50-knot vessel

Permanent Set of Plating

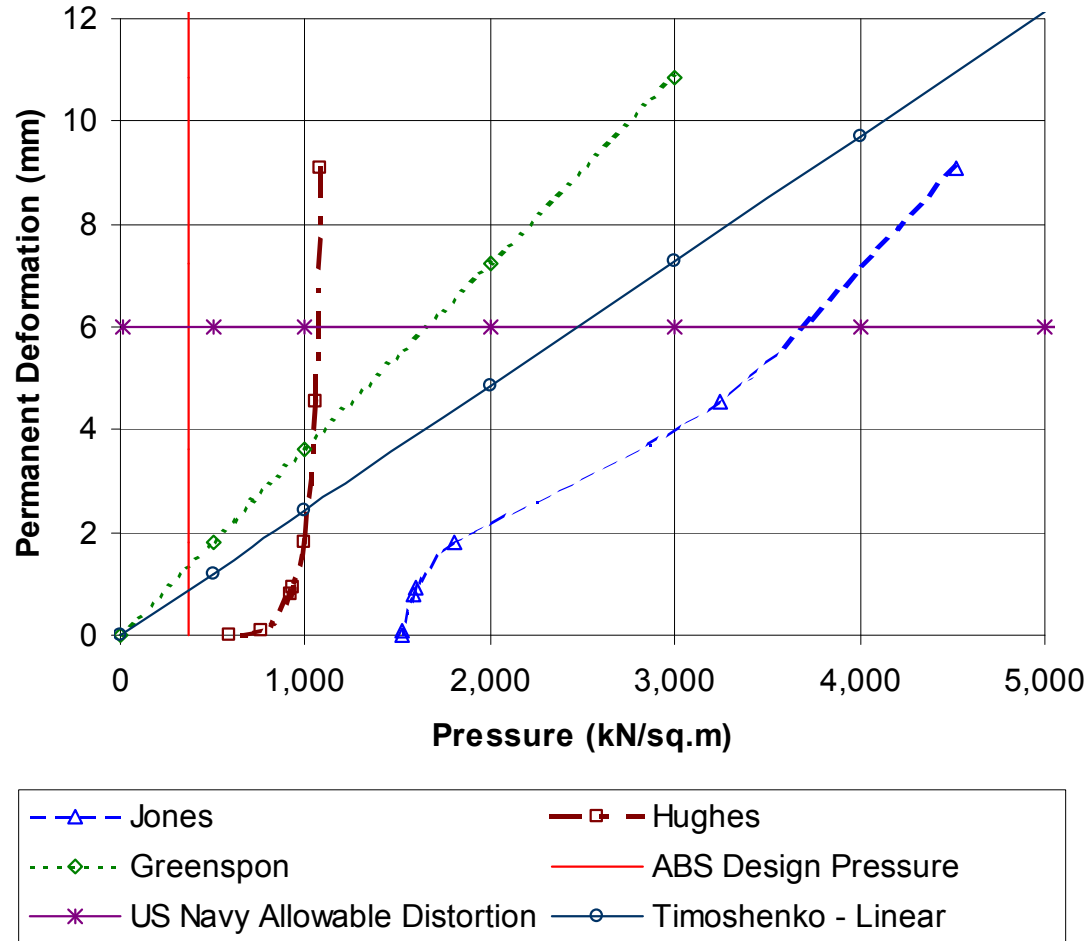

Jones and Walters (1971), Hughes (1983), and Greenspon (1955)

Allowable Stress Levels

- Third leg of the structural design triangle
 - Loads, nominal design loads and estimates of maximum lifetime loads
 - Analysis methods, direct scantling determination, and maximum stress analysis
- Must be different types of allowable stress level
- U.S. Navy interaction formula for stiffeners

$$\frac{f_c}{0.8F_c} + \frac{f_b}{F_b} \geq 1.0$$

f_c = the maximum compressive stress from hull girder bending

F_c = the column strength of the stiffener-plate combination

f_b = the maximum compressive bending stress in the stiffener from lateral loads

F_b = the allowable bending stress

- Includes several factors of safety
 - If yield strength and ultimate strength are equal, allowable stress is 0.63 of the yield strength
 - Factor 0.8 on column strength reflects uncertainty actual strength
 - Factor reduced to 0.67 if the slenderness ratio of column > 60
 - ABS HSC guide allowable stress for bottom plating
 - Slam loads $\sigma_a = 0.90$ of the welded yield strength for aluminum
 - Hydrostatic loads $\sigma_a = 0.40$ of the welded yield strength for aluminum

Buckling Strength

Buckling Strength of Plating

- U.S. Navy Design Data Sheet 10-4, Strength of Structural Members
 - Bleich and Ramsey (1951):

$$\sigma_c = \frac{\pi^2 E \eta}{12 (1 - \nu)} \left(\frac{t}{s} \right)^2 K$$

σ_c = critical plastic buckling strength, E = Elastic modulus, ν = Poisson ratio

η = factor based on aspect ratio and shape of the stress-strain curve

K = a factor that depends on the aspect ratio, the condition of support at the edges, and the condition of loading on the edges.

- ABS HSC guide
 - Euler-Johnson method:

$$\sigma_c = \sigma_E \quad \text{when } \sigma_E \leq \sigma_y$$

$$\sigma_c = \sigma_y \left(1 - \frac{\sigma_y}{4\sigma_E} \right) \quad \text{otherwise.}$$

$$\sigma_E = 0.9 m E \left(\frac{t}{s} \right)^2$$

m = 4.0 for longitudinally stiffened shell and deck plating

Buckling Strength of Plating (Cont.)

- Paik and Duran (2004)
 - Yield strength weighted by relative areas of HAZ and base metal

$$\frac{\sigma_{x0}}{\sigma'_{Yp}} = \begin{cases} 1.0 & \text{for } \beta' \leq 0.46 \\ -0.215\beta' + 1.1 & \text{for } 0.46 \leq \beta' \leq 2.2 \\ -0.083\beta' + 0.81 & \text{for } \beta' > 2.2 \end{cases}$$

$$\beta' = \frac{s}{t} \sqrt{\frac{\sigma'_{Yp}}{E}}, \quad \sigma'_{Yp} = \frac{P_p}{s l},$$

$$P_p = (1 - 2s'_p)(s - 2s'_p)\sigma_{Yp} + 2[ls'_p + (s - 2s'_p)s'_p]\sigma'_Y,$$

s'_p = width of the heat affected zone (HAZ) around the boundary of the plate.

σ'_Y = yield stress in the HAZ, and

σ_Y = yield stress in the unwelded base metal.

Buckling Strength of Stiffeners

Euler

$$\sigma_{cE} = \frac{\pi^2 E}{\left(\frac{kl}{r}\right)^2}$$

σ_{cE} = elastic critical buckling stress, E = Elastic modulus,

k = the length of the column, r = the radius of gyration of the column, equal to $\sqrt{I / A}$,

I = lowest moment of inertia of the cross section of the column

A = cross sectional area

k = a factor on column length dependent on end conditions.

- Fixed end columns, $k = 1/2$,
- Stiffened plate panels, $k = 1.0$ (opposite directions on opposite sides of supports)
- Overstates strength of short columns because of yield strength limits
- Tangent modulus approach
 - o E_t = instantaneous slope of stress-strain curve after proportional limit exceeded

$$\sigma_{cp} = \sigma_t = \frac{\pi^2 E_t}{\left(\frac{kl}{r}\right)^2}$$

- o Requires an iterative approach to solution.

Buckling Strength of Stiffeners (Cont.)

- Column Research Council (Johnston, 1976)
 - Upper limit of elastic buckling failure defined average stress = 1/2 the yield strength at a slenderness ratio:

$$C_c = \sqrt{\frac{2\pi^2 E}{\sigma_y}}$$

- Slenderness ratio less than C_c :

$$\sigma_{cp} = \left[1 - \frac{(kl/r)^2}{2C_c^2} \right] \sigma_y$$

Substituting:

$$\sigma_{cp} = \left[1 - \frac{\sigma_y}{4\sigma_{cE}} \right] \sigma_y$$

- Used in the ABS HSC guide and the HSNV rules

Buckling Strength of Stiffeners (Cont.)

- U.S. Navy DDS 100-4 uses straight-line simplification
 - Slenderness ratio defined as:

$$C = \frac{kl}{r} \sqrt{\frac{\sigma_y}{E}}$$

Column strength calculated as σ_{cp} / σ_y .

σ_{cp} = elastic-plastic critical buckling stress

$C \geq 4.8$, Euler equation used

$C \leq 1.4$, limiting yield strength is used

Intermediate values determined by straight-line interpolation

Transition point from Euler buckling to straight-line interpolation at $C = 4.8$

$kl/r = 144$ for mild

$kl/r = 104$ for 5086-H116 aluminum

Linear elastic Euler buckling equation used where plasticity effects become slightly important.

Buckling Strength of Stiffeners (Cont.)

- Paik and Duran (2004):
 - o Yield strength that is weighted by the relative areas of HAZ and base metal

$$\sigma_{xu} = \frac{\sigma'_{Yseq}}{\sqrt{C_1 + C_2(\lambda')^2 + C_3(\beta')^2 + C_4(\lambda'\beta')^2 + C_5(\lambda')^4}} \leq \frac{\sigma'_{Yseq}}{(\lambda')^2}$$

$$\lambda' = \left(\frac{1}{\pi r}\right) \sqrt{\frac{\sigma'_{Yseq}}{E}}, \quad \beta' = \frac{s}{t} \sqrt{\frac{\sigma'_{Yp}}{E}}, \quad \sigma'_{Yp} = \frac{P_p}{s l},$$

$$P_p = (1 - 2s'_p)(s - 2s'_p) \sigma_{Yp} + 2[1s'_p + (s - 2s'_p)s'_p] \sigma'_Y,$$

$$\sigma_{Yseq} = \frac{P_s}{st + h_w t_w + b_f t_f}$$

$$P_s = (s - 2s'_p)t \sigma_{Yp} + 2s'_p t \sigma'_{Yp} + (h_w - h'_w) t_w \sigma_{Ys} + h'_w t_w \sigma'_{Ys} + b_f t_f \sigma_{Ys}$$

σ_{Ys} = yield strength of the stiffener web σ'_{Ys} = yield strength of the HAZ of the stiffener web

σ_{Yp} = yield strength of the plate σ'_{Ys} = yield strength of HAZ of the plate

h_w, t_w = depth and thickness of the stiffener web h'_w = width of HAZ on the stiffener web

s'_p = width of HAZ on the plate r = radius of gyration of the plate-stiffener = $\sqrt{I/A}$,

A = cross sectional area of the plate-stiffener I = Moment of Inertia of the plate-stiffener

Coefficients for Paik-Duran Stiffener Buckling Formula (Paik and Duran, 2004)

Coefficient	Initial Deformation		
	Slight	Average	Severe
C_1	0.878	1.038	1.157
C_2	0.191	1.099	2.297
C_3	0.106	0.093	0.152
C_4	-0.017	-0.047	-0.138
C_5	1.30	1.648	3.684

Stiffener Tripping

- Torsional instability
 - Asymmetric sections (angles) more susceptible
 - Shear center offset from centroid
 - Rotation under load
 - Members with little or no flange (bulb flats and flat bar) have little lateral stability

Comparison of Tripping Stresses (Vara et al., 2003)

Criteria	Symmetric Tripping Stresses (psi)		Asymmetric Tripping Stresses (psi)		
	Section 1	Section 2	Section 3	Section 4	Section 5
ABS	32,414	30,390	33,149	31,439	26,823
GL	30,429	31,686	31,587	30,255	27,670
DDS	33,755	33,500	N/A	N/A	N/A
Adamchak	32,662	33,407	N/A	N/A	N/A
LR Navy	33,773	33,599	33,924	33,868	28,938

Stability of Stiffener and Frame Flanges and Webs

- ABS HSNC Rules
 - Flat bars, outstanding face bars, and flanges:
 $d/t \leq 0.5 (E/\sigma_y)^{1/2}$
 - Webs of built-up sections, angles, and tees;
 $d/t \leq 1.5 (E/\sigma_y)^{1/2}$
 $d/t \leq 1.54 (E/\tau_y)^{1/2}$
 $d/t \leq 1.15 (E/\tau_y)^{1/2}$ in areas subjected to slam pressures
 - Webs of bulb flats
 $d/t \leq 0.85 (E/\sigma_y)^{1/2}$

- σ_y and τ_y are the yield strength of the unwelded aluminum in tension and in shear.
 - Same equations are used for steel and aluminum
 - Higher strength steel, b/t (flanges) ≤ 12
 - 5083-H116 aluminum, b/t (flanges) ≤ 9
 - In general, the thickness of aluminum structural members should be about $12/9 = 4/3$ times thicker than an equivalent steel member

Finite Element Analysis

- Required by most classification societies and naval authorities for the design of all but the most routine vessels
 - Doesn't answer all of the questions
 - Poses many of its own.
- Finite element modeling techniques for aluminum structure same as for steel structure
 - Materials have similar Poisson ratios
 - Material constitutive equations behave in the same manner
 - Guidance and rules of thumb for steel structure is applicable to finite element analysis of aluminum structure.
- Effective breadth of plating
 - Can only be modeled with a very fine mesh, large displacement elastic-plastic finite element analysis with many load steps
 - Same degree of refinement is necessary for buckling analysis
 - Linear elastic buckling analysis can seriously overestimate strength of structure
 - Such refinement is impractical in modeling of entire ship
 - Even when analyzing small sections of the structure

Finite Element Analysis

- o Options for Finite Element Analysis
 - Model stiffeners with only effective plate
 - Cross-sectional area of the hull is deficient
 - Model stiffeners with all plating effective
 - Overestimates stiffness of stiffeners and frames
 - Offset the stiffeners from plate by height of neutral axes
 - Overestimates stiffness of stiffeners and frames
- o Preferred Method
 - Model all of the plating
 - Calculate the inertia of the stiffener as that with effective plate only.
 - Evaluate stress offline
 - Use bending moments and forces from finite element analysis
 - Calculate section modulus with effective plate

Summary of Design

- Some of aspects of design of aluminum ships reviewed
 - Emphasis on high-speed craft
 - Review not exhaustive
 - Provided insight into various methods of design and analysis
 - Aluminum and steel both metallic structures
 - Mechanics of materials used for their analysis are different
 - Significant differences in material properties of the two materials
 - Particularly in the elastic modulus
 - Necessitates differences in design formulations.
- Different methods of design exist
 - Rules of classification societies
 - Procedures of naval authorities
 - Methods give similar scantlings for the same vessel design
 - Loads and allowable stress levels are different
 - Designer must not mix procedures
 - Don't use allowable stress levels from one procedure with the loads from another.

Summary of Design (Cont.)

- Equations for estimating design loads
 - Most high-speed and unusual hull forms
- Final design generally based on more thorough analysis
 - Data from at-sea tests on similar vessels
 - Model tests
 - Hydrodynamic analysis
- Such methods not well validated
 - Inconsistent results possible
 - Similar vessels designed using different methods
 - Same method but by different persons
 - Very erudite analysis may have limited accuracy

Summary of Design (Cont.)

- Aluminum does not have a pronounced yield point like steel
 - Difference in behavior not reflected in rules for design
 - Plating under lateral pressure
 - Membrane action of plate
 - Permanent set under extreme loads
- Reduced strength of welds and HAZ in aluminum
 - Accounted for conservatively in design methods
 - Lowest strength used in design equations
 - More accurate method needed
 - Weighted average strength
 - Mass of base and welded metal
 - Validated for compressive strength of welded panels
 - Not validated for structure in tension

Chapter 4

Structural Details

- Aluminum structural details as varied in steel vessel
 - Same problems aluminum and steel
 - Same structural detail can solve same structural problem
- Aluminum concern
 - Increased sensitivity to fatigue for aluminum
 - Joining dissimilar metals
 - Welding process for aluminum preclude details with poor accessibility
- Greater through-thickness strength in aluminum plate
 - Structural details stronger in way of passing members
 - Transverse frames or bulkheads.
- Structural details acceptable in smaller craft not always suited for larger vessels
 - Low hull girder bending stress
 - May have satisfactory service life with poor structural details
- Best details often have the fewest welds

Details Specific to Aluminum Structure

- Wide variety of extrusions to meet differing needs
 - Special extrusions sometimes will present different geometries and will require different details
- Deck Panels
 - Extruded panels
 - Stiffeners extruded into them
 - Stiffened with flat bar, bulb flat, angle, or tee stiffeners
 - Detailing may be same as if the stiffeners are welded to the plate
 - May be different because of closely spaced stiffeners
 - Too close for conventional welding.
 - Sandwich panels

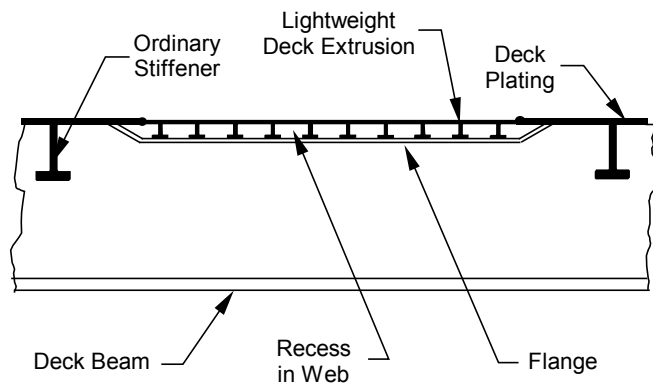

Deck Panels (Cont.)

- At bulkheads
 - o Stiffeners welded to bulkhead plate
 - o Difficult to make extrusion continuous through a bulkhead
 - o Generally made intercostal.



Deck Panels (Cont.)

- o Alternate design

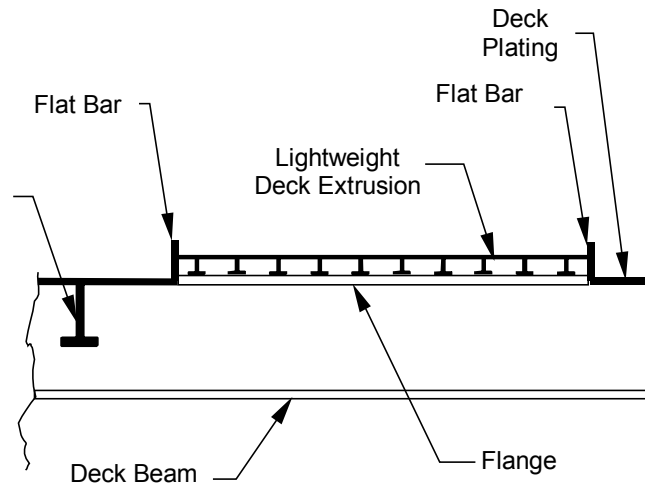

- o Sandwich Panel Detail

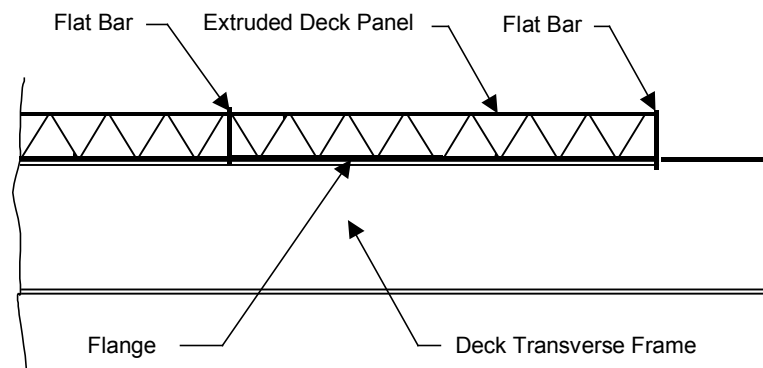

Tubular Stiffeners

- Well suited to fabrication of aluminum structure
 - Lightweight structure such as deckhouses
 - Also used in steel
 - Less chance of corrosion in aluminum
- Good stability as stand-alone members
 - Well suited to stick construction



Egg Crate Detailing

- Good through-thickness properties
 - No concern for innerlaminar exclusions
 - Cruciform welds will not fail by splitting the intervening plate
- Better suited for stick type construction

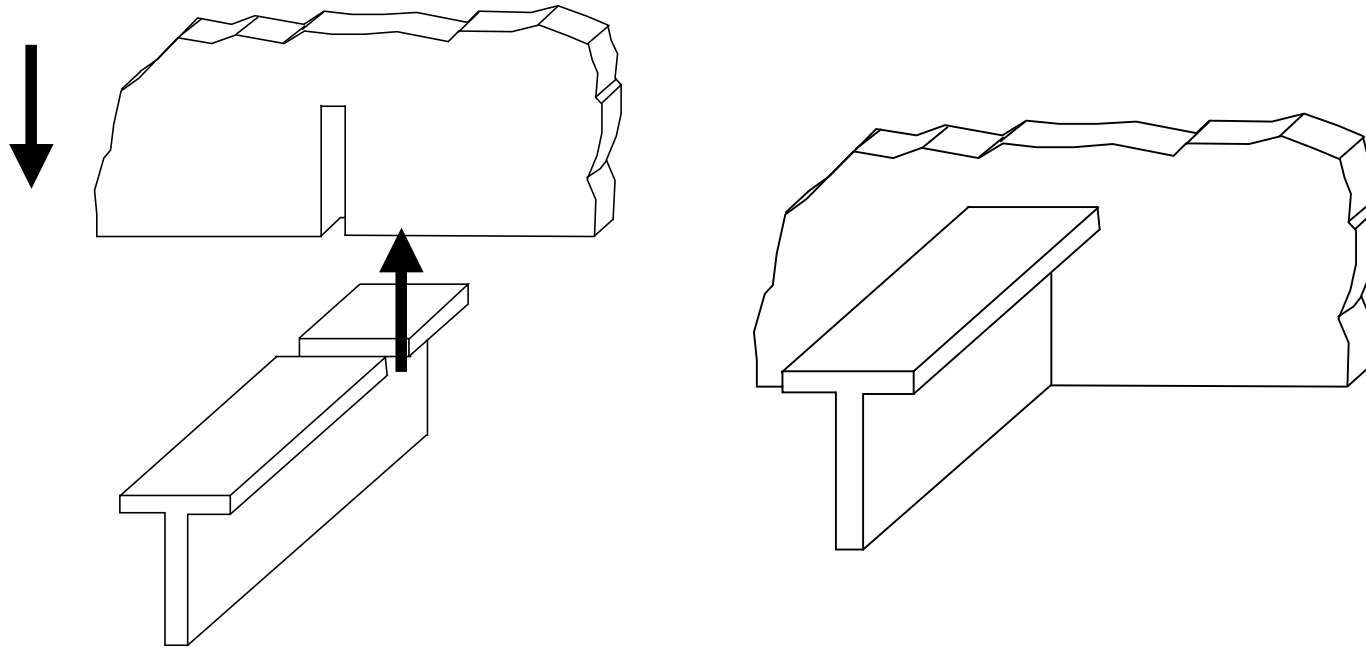

Special Extrusions at the Gunwale

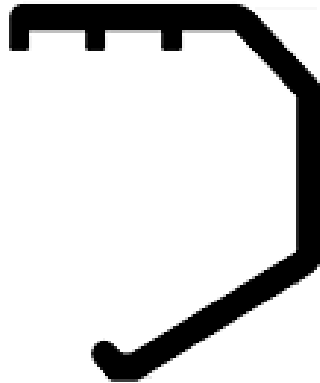
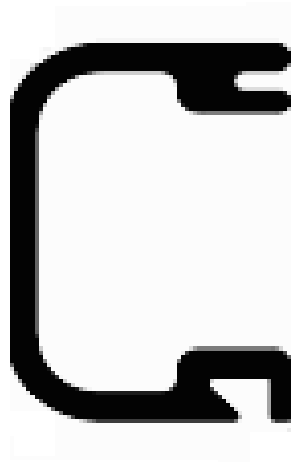

Summary of Structural Details

- Some structural details from steel ships can be used on aluminum vessels
- Some details unique to aluminum construction
- Shipbuilders to determine type of detail
 - o Best suits the construction techniques used in the yard
 - o Higher quality details for more critical joints
- Where unproven details are used
 - o Extruded deck panels, for example
 - o Exercise caution without fatigue strength data

Chapter 5

Welding and Fabrication

- Similarities between fabricating with aluminum and steel
- Transition from steel to aluminum
 - No significant changes in facilities or personnel
 - Many shipyards that build with both materials at the same time
- Significant differences
 - Welding in an enclosed area is a necessity for aluminum
 - Electromagnetic devices for material handling and for holding work in place are useless
 - Oxyacetylene, gas or carbon arc cutting not used on aluminum
- Workers need to learn new procedures
 - Same welders generally don't work on both at the same time
- Closer link required between design and fabrication
 - Design often changed to fit the advantages and limitations of construction capabilities

Guidance on Welding

- American Welding Society Committee D.3 on Welding in Marine Construction
 - Guide for Aluminum Hull Welding (AWS, 2004)
 - Thoroughly reviews welding aluminum for marine fabrication
- The Aluminum Association
 - Welding Aluminum: Theory and Practice
- American Bureau of Shipping Part 2, Aluminum and Fiber Reinforced Plastics
 - Part of the Rules for Materials and Welding
- Military Standard MIL-STD-1689
- David W. Taylor Naval Ship Research and Development Center
 - Guide for the Use of Aluminum Alloys in Naval Ship Construction (Beach et al., 1984)
 - Volume on fabrication

Cutting and Forming

- Aluminum is softer than steel
 - Easily cut with steel cutting tools
 - Sawing, machining, and other mechanical means of cutting performed with ease
- Sawing performed with blades that have relatively coarse teeth
 - Blades should have a high speed
 - Band saws and hand-held or stationary rotary saws
 - Jigsaws and saber saws are used for cutting curved shapes
 - Hole saws for circular openings
- Saw-cut edge is generally suitable for welding
 - Smooth first by filing, planing, routing, sanding, polishing, or milling prior to solvent cleaning
- Hacksaw not recommended except for small, thin pieces
 - Time-consuming
 - Does not present a very smooth edge
- Shears for cutting plate up to 4.8 mm (0.188 in) thick
 - Edge should be dressed and cleaned prior to welding
 - Do not shear exposed edges on alloys with magnesium content greater than 3 percent
 - 5083, 5086, or 5456, 5383, 5059, etc.
 - Edge can become sensitive to stress-corrosion cracking
- Nibbler (similar in action to a shear) is used for curved edges

Plasma-Arc Cutting

- Numerically controlled plasma-arc cutting machines
 - o Fastest and most accurate method of cutting aluminum
- Cut edge is ready for welding, with only cleaning required
- Intricate shapes can be easily obtained
 - o Cut outs through which structural shapes can be passed
- Used today in even small boatyards
 - o Economical to have an outside shop prepare plates
- Requires additional advanced planning
 - o All openings and cutouts made at one time
 - Not when workers are fitting systems such as piping and electrical systems.
- Plasma-arc cutting
 - o Either dry or wet
 - o Dry cutting has plate usually positioned above a pond of water
 - o Wet cutting the plate is submerged

Fluid Jet Cutting

- Jet of water includes abrasive particles
 - o Very high pressure stream from a nozzle
- Very clean and accurate cut
 - o No heat-affected zone
- Plates from 1 mm to 100 mm (0.04 in to 4 inches) thick
 - o Cut at rates of 3,500-mm/min. (140 in/min.) for the thinner sheet
 - o 30-mm/min. (1.2 in/min.) for the thicker plate

Bending Plates

- 5xxx-series aluminum alloys are work hardened
 - Overworking in forming operations can have a deleterious effect on mechanical properties
- Plates can be easily bent in a press- brake
- Minimum bend radii should be no less than those recommended by the AWS guide

Minimum Bend Radii for Cold Bends in Aluminum Alloys as a Multiple of Plate Thickness, t (AWS, 2004)

Alloy	Base Metal Thickness (mm / in)				
	3.2 / 0.125	4.8 / 0.188	6.4 / 0.25	9.5 / 0.375	13 / 0.50
5086-H116	1.5t	2t	2.5t	3t	4t
5083-H116	1.5t	2t	2.5t	3t	4t
5454-H34	2	2t	2.5t	3t	4t
5456-H116	1.5t	2t	2.5t	3t	4t
6061-T6	2.5t	3t	3.5t	4.5t	5t

Forming Plate

- Plates can be curved with rollers
 - Warped shapes with different curvatures at opposite ends
- Forming compound curvature is extremely difficult
 - If small amount of cross-curvature is needed
 - Plate is rolled to the principal direction of curvature
 - Forced into position against hull framing members
 - Difficult operation
 - Scantlings of framing members may have to be selected for forming forces
- Roll forming compound curvature
 - Loose filler material such as sawdust or soft wood shavings applied at rolls
 - Curved rollers also used to form compound curvature
 - Either process requires a great deal of skill
- “Orange peel” sections
 - Triangular plates
 - Given single curvature or
 - Some compound curvature using a press
 - Joined together to form approximation of the desired shape
- Compound curvature usually avoided in the hull form
 - Limitation of aluminum

Use of Heat in Forming and Straightening

- Forming of aluminum with heat is more difficult than in steel because
 - 5xxx-series alloys cannot be heated to high temperatures
 - Metallurgical changes
 - Susceptible to corrosion
 - Forming at higher temperatures must be done under controlled conditions
 - 6xxx-series are heat-treated
 - Heated for forming only with care
- If extensive shaping of plates required
 - Use annealed tempers, such as 5083-0 plate
 - Less strength than the work-hardened tempers
 - Design calculations should reflect the reduced strength
- Careful control of the shaping process is required
 - Could lead to sensitization of material previously not sensitized
 - Requires approved procedure
- Select temperature at which the operation is to be performed
 - Use lowest temperature that will result in the desired amount of softening
 - Thicker plate has lower yield strength
 - Thicker material more likely to need higher temperatures for forming
 - Greater risk of not meeting the specified strength after heating and forming

Reduction of Mechanical Properties of 5456-H116 with Increased Thickness (Hay and Holtyn, 1980)

Thickness Range		Yield Strength		Ultimate Strength		Elongation (%)
mm	inches	(MPa)	(ksi)	(MPa)	(ksi)	
1.60–12.69	0.063–0.449	228	33.0	317	46.0	10
12.70–31.77	0.500–1.250	228	33.0	317	46.0	12
31.78–38.12	1.251–1.500	214	31.0	303	44.0	12
38.13–76.22	1.501–3.000	200	29.0	283	41.0	12
76.23–101.60	3.001–4.000	172	25.0	276	40.0	12

Plate Heating Process

- Thick plates be heated for shaping in a furnace
 - Held for several hours and “soaked” at the desired temperature
 - Maximum temperature should be less than 260 °C (500 °F) to maintain corrosion resistance
 - May reduce strength
 - Design calculations must be adjusted for reduced mechanical properties
- Test program required to establish procedures
 - Specimens subjected to the required heating cycle
 - Mechanically deformed
 - Tensile testing for mechanical properties
 - Test in accordance with ASTM Specification B 928-04 for marine-grade aluminum plate of 5xxx-series
 - ASTM G 66 (ASSET) for exfoliation resistance
 - ASTM G 67 (NAMALT) test for intergranular corrosion resistance

Forming Structural Shapes

- Aluminum structural shapes are easily formed in light sections
 - Deeper sections are more difficult to bend without causing buckling of flanges or webs
- Bend tee stiffeners by cutting V-notches in the webs or cutting the flanges
 - Holes should be drilled at the ends of the notches prior to forming to prevent cracking
 - Not used if design is based on the unwelded strength of the shape
- Special rollers with slots to support webs of tees and angles
- Heating may be necessary
- When there is a considerable amount of curvature (transverse frames)
 - Cut plate to the shape of the hull to form the web
 - Inside edge straight or slightly curved for welding a flange
 - Can also bend edge to form flanged plate
 - Least expensive alternative
 - Cost of numerical cutting is low
 - Shipyard labor is saved

Structural Assembly

- Pre-outfitted structural assemblies
 - o Aluminum compared to steel
 - Larger subassemblies can be built of the same weight
 - More care required in handling larger assemblies
 - Temporary welded handling pads a necessity for handling aluminum subassemblies
 - Lighter scantlings
 - Ineffectiveness of electromagnetic handling devices
- Distortion of aluminum subassemblies can be greater than with steel subassemblies
 - o Temporary stiffening members to hold the subassembly prior to its being welded into the other structure
- Aluminum welding not tolerant of gaps, especially uneven gaps
 - o Greater care must be taken with the fit-up of joints prior to welding
- Punch marks or scribe marks can cause problems
 - o Sites of fatigue crack initiation
 - o Should be welded over

Fabrication Facilities

- Should be fabricated in enclosed conditions
 - Temporary shelters or permanent buildings
- Coefficient of thermal expansion about twice as great as the coefficient of steel
 - Dimensions will vary greatly as the temperatures change
 - Localized changes in temperature (direct sunlight) induce warping of structural assemblies
- Protection from wind for shielding gas when welding
- Moisture and high humidity has serious effect on the quality of aluminum welds

Panel Construction

- Special aluminum panel lines for this purpose
 - Plates are butt welded to form large panels
 - Stiffeners welded first in mechanized stations
 - Frames are fitted over the stiffeners and welded
 - Curved hull sections formed by laying the plates in jigs
 - Butt weld plate
 - Fit the stiffeners and frames.
- “Stick” construction
 - Bulkheads and frames are first laid up and tack welded together
 - Stiffeners are then fitted to the frames
 - Entire assembly is welded
 - Plating laid over the stiffening
 - Welded to the frames and stiffeners
 - Avoids having to construct jigs to handle curved sections
 - More advantageous for one-off designs
 - Better access to the details of stiffener-frame intersections
 - Details easier to weld
 - Small stiffeners typical of smaller craft
 - Alignment of intercostal members easily accomplished



Hull with stick construction of framing (Courtesy of Gulf Craft)

Welding

- Gas Tungsten Arc Welding (GTAW) (also known as TIG)
- Gas Metal Arc Welding (GMAW) (also known as MIG)
 - GTAW is generally much slower than GMAW
 - Used for welding thin materials, 1.5 mm (1/16 inch) or less
 - GMAW can also be used with thin material if pulsed power is used
- Selection of the filler metal depends on alloys being welded
 - Some shipyards try to use the same filler metal for all alloys
 - Minimize problems with inventory control and supply to the welder
- Shielding gas
 - Either helium or argon or a combination of the two
 - Argon is the most effective in oxide removal when used with a direct current, electrode positive arc
 - Preferred for thicknesses up to 19 mm (0.75 in)
 - Helium shielding produces a higher voltage
 - Mixtures of helium and argon are generally used
 - Greater thicknesses
 - Welding out of position
 - Protection of the weld from rain and other excessive moisture is essential
 - Protection from the wind be provided to avoid disrupting the flow of the shielding gas

Joint Preparation

- Allowable root gap guidance from AWS guide
 - o Vary depending on the weld position and joint design
 - o Butt welds in 6-mm to 10-mm (1/4-inch to 3/8-inch) plate
 - Root gap 0.0 to 2.4 mm (0.094 in)
 - Butt joints must be beveled unless the thickness of the plate is 4.8 mm (0.188 in) or less
- U.S. Navy
 - o Welding procedures in MIL-STD 1689, Fabrication, Welding, and Inspection of Ship's Structure
 - o Specifications for joint design, including root gaps, are given in MIL-STD-22, Welded Joint Design
 - MIL-STD-22 makes no differentiation between steel and aluminum
 - Permits root gaps as large as 4.8 mm (0.188 in) for butt welds in all plate thicknesses without backing
 - Large root gaps may be permitted by the US Navy specifications
 - AWS guidance should be followed

Alignment Prior to Welding

- No guidance from AWS on alignment
- ABS Rules for Materials and Welding have table
 - o Same tolerances required by MIL-STD 1689 after welding.

Permissible Alignment of Butt Welds (ABS)

Base Metal Thickness		Maximum Misalignment
Millimeters	Inches	
$t < 9.5 \text{ mm}$	$t < 0.375$	1.5 mm (0.625 in)
$9.5 < t \leq 19.0$	$0.375 < t \leq 0.75$	3.0 mm (0.125 in)
$19.0 < t \leq 38.0$	$0.75 < t \leq 1.5$	5.0 mm (0.188 in)
$t > 38.0$	$t > 1.5 \text{ in}$	6.0 mm (0.25 in)

Fit-up for Welds

- Fit-up for fillet welds
 - o ABS rules gap < 1.5 mm (0.063 in).
 - o 1.5 mm $<$ gap < 5.0 mm (0.188 in), increase fillet weld size by the amount of the gap over 1.5 mm (0.063 in)
- Butt welds and fillet welds, ABS permits excess gaps to be filled by buttering
 - o Butt welds, buildup $\leq 1/2$ of plate thickness or 12.7 mm (0.50 in)
 - o Fillet welds, buildup \leq plate thickness or 12.7 mm (0.50 in).
- Edge preparation prior to welding
 - o More demanding for aluminum than for steel
 - o Single or double bevel or a J-joint required for all joints over 4.76 mm (0.188 in)
 - o Can sometimes be produced during numerically controlled plasma arc cutting process
 - o Otherwise, use high-speed milling machines, routers, planers, and saws
 - o Sanding and grinding are not recommended for edge preparation
 - Leave residue that is difficult to remove

Cleaning before Welding

- Chemically clean with a solvent at least 75 to 150 mm (3 to 6 inches) either side
 - Need to have a clean surface that is free of oil, grease, oxides, and other contaminants
 - Prevents contaminating the weld or the shielding gas with surface residue
- Brushed with a stainless steel wire brush
 - Hand or power brush
- Interval between cleaning and welding
 - Preliminary fit-up should be made prior to cleaning
 - AWS recommends covering the cleaned surfaces with strips of heavy paper that are taped in place if there is any length of time between cleaning and welding
 - ABS limits time between cleaning and welding to 8 hours
 - MIL-STD-1689 limits the time to 16 hours
- Environmental concern
 - Limits solvents to be used
 - American National Standards Institute ANSI Z49.1, Safety in Welding, Cutting, and Allied Processes
 - Provides guidance on solvent selection.

Tolerances

- Aluminum more prone to distortion from welding than steel
 - Tolerances for fairness in aluminum structure not as strict as for steel
- Unfairness in aluminum plating
 - ABS Rules for Materials and Welding (Aluminum)
 - Similar to MIL-STD-1689
 - Greater tolerances are permissible in aluminum
 - 12.7 mm (0.50 in) strength deck plate on 610 mm (24 in) stiffener spacing:
 - Tolerance = 9.5 mm (0.375 in) for aluminum
 - Tolerance = 6.4 mm (0.25 in) for steel
- Fairness of frames and stiffeners
 - Primary strength structure
 - Subject to dynamic loading, such as bottom slamming
 - MIL-STD 1689 and the ABS aluminum rules have the same tolerance
 - $\text{Unfairness} < 530 l / d_w$ (mm)
 - l is the span in meters
 - d_w is the depth of the web in mm
- Tolerances for plate and stiffeners determined by surveys
 - Tolerances achieved in normal shipbuilding practice
 - Effects of tolerances on structural strength not as extensively studied for aluminum as for steel

MIL-STD 1689 Aluminum Plate Fairness

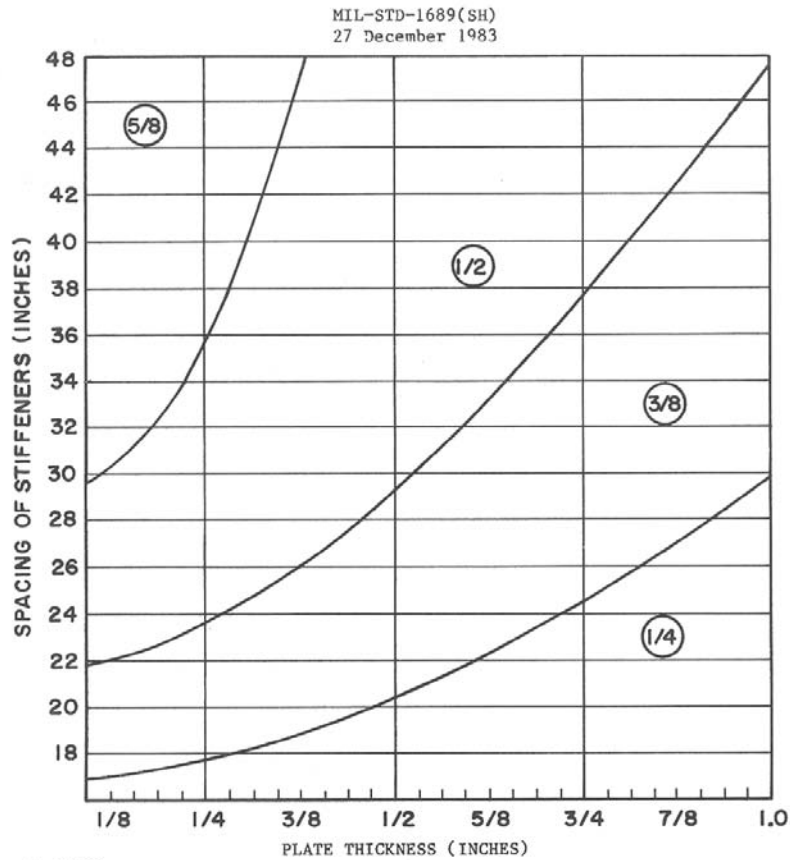

SH 12483

Aluminum plate in critical areas

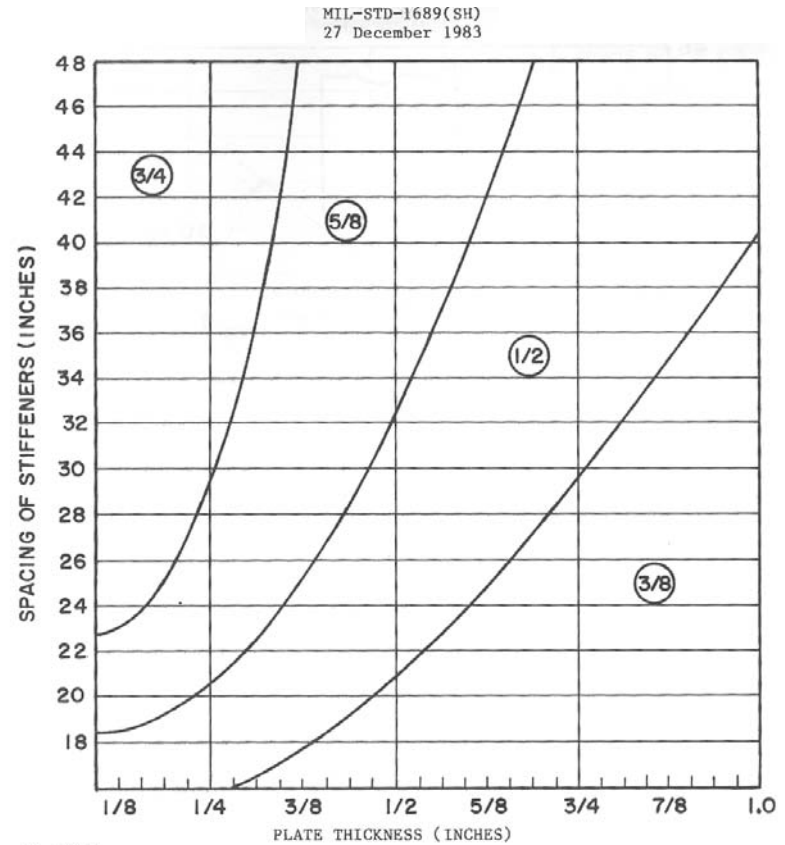

SH 12484

Aluminum plate in secondary areas

Flame Straightening of Aluminum

- Flame straightening to fair plate generally not permitted in aluminum
 - Special permission required from classification society or U.S. Navy
- Hay and Holtyn (1980)
 - 5xxx-series aluminum should not be heated to above 288 °C (550 °F)
 - Should not be permitted to remain at that temperature for any length of time
 - Special temperature-sensitive crayons used
 - Two operators are generally required for this operation
 - First operator has crayons that melt at 288 °C (550 °F) and an oxy-acetylene torch to heat the plate
 - Second operator has a device for providing a fine spray of water and air
 - Operator heating the plate constantly checks the temperature with the crayon
 - When crayon melts
 - Second person immediately cools the plate to 66 °C (125 °F)
 - Extreme care required to avoid overheating
 - Lowers the mechanical strength
 - Reduces the corrosion resistance
 - Neither easily determined by ordinary quality control means

Other Means of Straightening Plate

- Weld beads to straighten
 - Lay weld beads in a pattern on the surface of the plate
 - Not generally permitted as it reduces strength of plate
- Radical distortions in plating
 - Cut slit in plate
 - Straighten plate or possibly distort it in the opposite direction
 - Reweld
 - Special permission may be required for such an operation

Minimizing Distortion During Welding

- Plate should not be free to rotate about the axis of the weld during welding
- Design of the joint should be symmetrical
- Welding procedures should be symmetrical
- Minimum welding heat should be used
- Excessive filler material should be avoided
- Fillet welds should be made with minimum heat input
- Fillets should be no greater than required for strength
- Fit-up should be made as accurate as possible to minimize weld size
 - Minimize root gaps and irregularities in the root gaps
- Sequence of welding is very important
 - Butts and seams in plating should progress outward from the center
 - Butts in strakes of plating welded before the longitudinal seams
 - Beneficial to weld only small portions at a time
 - Welding short intermittent beads
 - Returning to the weld seam after structure farther away has been welded
- Intermittent fillet welds
 - Smaller craft
 - Non-critical structure

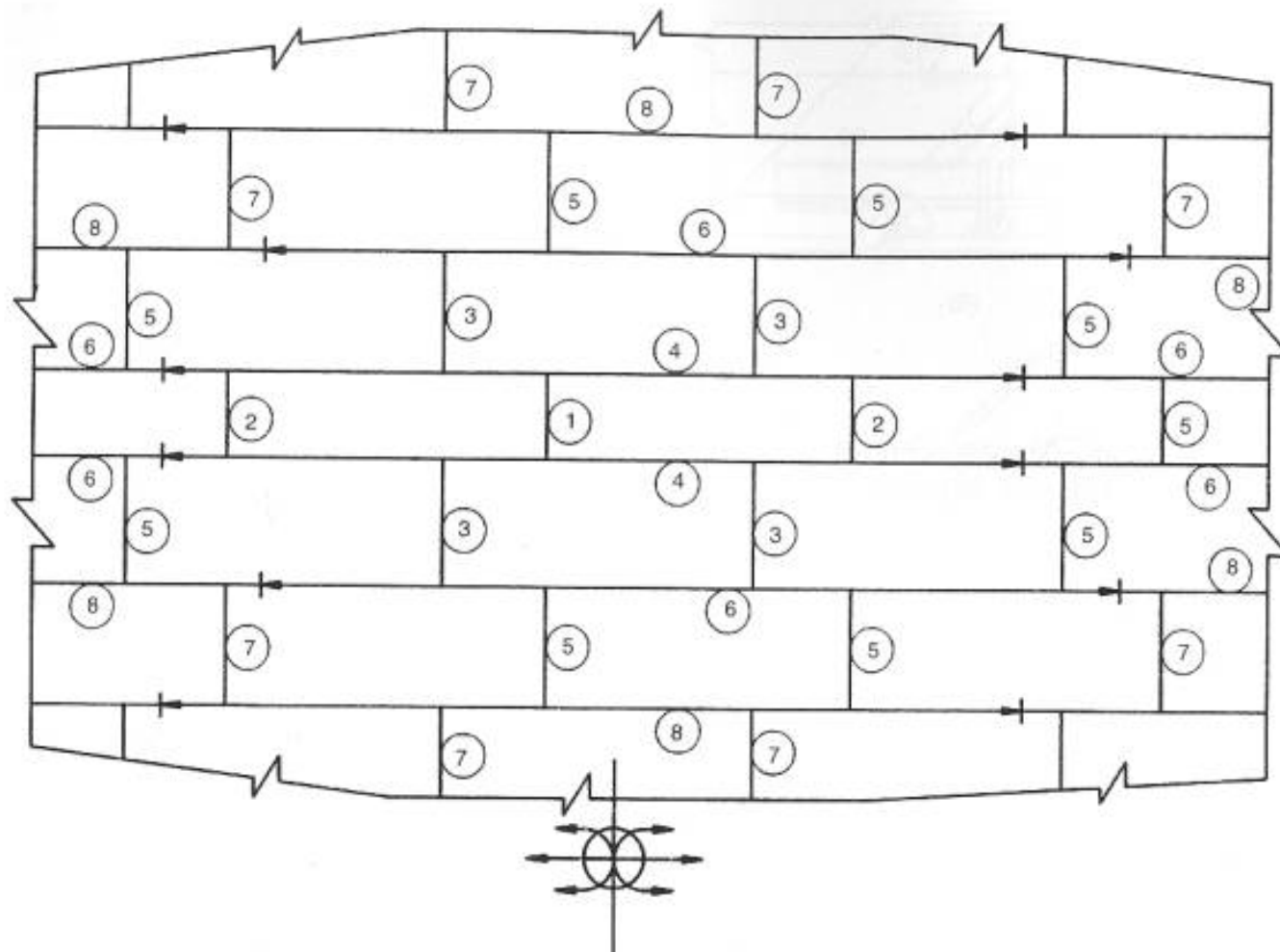

Recommended welding sequence for butt welds (AWS, 2004)

Summary of Welding and Fabrication

- Fabricating structure with aluminum is similar to steel construction
 - More difficulties involved
- Cutting aluminum generally not as fast as steel cutting
 - Faster with plasma arc or water jet
- Aluminum can be formed into different shapes
 - Heating is very difficult
 - Compound curvature of plates should be avoided
- Welding aluminum more expensive than welding steel
 - More joint preparation and cleanliness required
 - Need for shielding gas
 - Somewhat slower welding speeds
- Aluminum more prone to distortion during welding
 - More care needed with welding procedures to reduce distortion
- When distortions occur
 - More difficult to remove
 - Limitations on the use of heat on aluminum
- Extruded panels reduce construction cost
 - Many welds of stiffeners to plate are eliminated.
 - Less distortion

Chapter 6

Riveting

- Once primary method for fabricating aluminum vessels
 - Seldom used today for fabricating primary hull structure
 - Used for some light joiner work
- Lack of skilled riveters in shipyards
 - Swaged mechanical fasteners used instead of rivets
- ABS Guide for Building and Classing High-Speed Craft (ABS, 2001)
- ABS Guide for Building and Classing High Speed Naval Craft (ABS, 2003)
 - Requirements pertain to welded vessels only
- ABS Steel Vessel rules (Part 3, Chapter 1, Section 2, paragraph 1.3)
 - 1969 rules should be consulted for riveted hull construction
- Det Norske Veritas rules do not specifically mention riveted construction
 - Special consideration must be made if a vessel built to those rules is to be riveted

Advantages and Shortcomings of Riveting

- No reduction in strength from heat of welding
 - Weight reduction made through higher design stresses
 - Use higher-strength alloys that are not weldable
- Excess weight from the lap joints
 - As much as 15 percent
 - Increase of 2.5 percent for weight of welds
- Closer tolerances because no welding distortions
- More labor-intensive than welding
 - Few well trained riveters today for marine construction
- Watertightness of rivet seams not done by mechanical caulking as in steel
 - Not used because of softness of aluminum
 - Sealing compound used between the plates
- Corrosion problems
 - Galvanic corrosion from different materials
 - Crevice Corrosion

Selection of Rivet Material

- Study by Anderson and Morton (1973)
 - Corrosion tests on riveted joints of 5456-H117 aluminum
- Plates riveted with 1100 aluminum alloy rivets
- Exposed to corrosive environment for one year
 - Flowing seawater
 - Edge corrosion
 - Localized attack under the riveted lap joint
 - 1.42 percent weight loss
 - Marine atmosphere 80 and 800 feet from the ocean
 - Experienced only light surface attack
 - Average weight loss of 0.04 percent
- 1100 alloy rivets showed poor corrosion resistance
 - Small regions of pitting
 - 1100 alloy has lower alloy content than the 5456-H117
 - Rivet material contributed to the corrosion of the plate
 - Rivets were cold worked
 - Created local anodic sites
 - Made the rivets susceptible to preferential corrosion attack

Selection of Rivet Material (Cont.)

- Study by Bieberich and Wong (1998)
 - Mechanical fasteners (bolts) on aluminum
 - Aluminum rivets are cold formed
 - Less corrosion resistance than bolts
- Plates of 5083-H3 and 2519-T87 aluminum
- Bolts
 - Grade 8 carbon steel
 - Variety of coatings
 - 316 stainless steel
- Exposed to a marine atmosphere 80 feet from the ocean for 2.5 years
 - All coated and uncoated carbon steel fasteners had significant corrosion
 - Least corrosion on those coated with zinc plating
 - Followed by zinc-nickel
 - Most corrosion on cadmium plated fasteners
 - Stainless steel bolts
 - No signs of corrosion
 - Plate had corroded under them
- Rivets should have composition close to material being joined
 - Difference in electrical potential between two materials in seawater leads to corrosion

Guidance for Riveted Design

US Navy Requirements

Military Standard 1689 (MIL-STD 1689)

Materials for Mechanical Fasteners (MIL-STD 1689)

Application	Type of fastener	Material
Where required for strength and where exposed to the weather, seawater, or wet spaces.	Rivet	Aluminum
	Lockpin	CRES
	Bolt and nut	CRES
Where required for strength and where not exposed to the weather, seawater, or wet spaces.	Lockpin	MS
	Bolt and nut	MS
Where strength is not a special consideration	Rivet	Aluminum
	Lockpin	Aluminum
	Bolt and nut	Aluminum
Nonstructural applications where rivet diameter is less than 5/16 inch and material thickness does not exceed 1/8 inch.	Rivet	Aluminum

MIL-R-5674 superseded by NASM5674

Published by the Aerospace Industries Association of America

For marine use, only the 5056-H32 alloy rivets should be used.

Swaged Fasteners (Lockpins)

- Military Specification MIL-P-23469
- Similar to a bolt
 - Threads are concentric, not in a spiral
- Two areas of threads
 - Short section close to the head
 - Used to hold the sleeve
 - Longer section at gripped by hydraulic device that secures the fastener
- Sleeve slipped over fastener
 - Special hydraulic unit draws the fastener
 - Presses sleeve tightly and pressing materials close together
 - Unit compresses the sleeve to hold it onto the fastener
- Unit pulls on the fastener, breaking it at the notched section
- Superior to a nut and bolt
 - Once set, the fastener will not loosen from vibration
 - Threads on aluminum bolts are weak
 - Easily stripped if the nut is cross-threaded or over-torqued
- Commercial fasteners equivalent to the military specification readily available
- Specification covers a number of alloys
 - Corrosion resistant steel, carbon steel, and aluminum
 - For marine use, the 6061 alloy aluminum fasteners should be used.

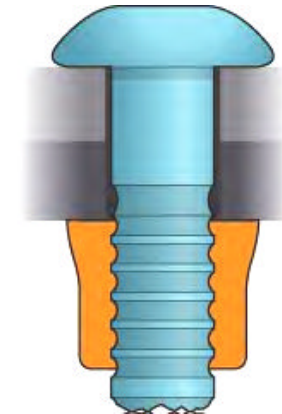

Classification Society Requirements

- ABS rules (Part 2, Chapter 5, Section 11
 - o Rivets to be ASTM specification B316, Standard Specification for Aluminum and Aluminum-Alloy Rivet and Cold-Heading Wire and Rods.
- Specification covers aluminum in the following alloys for rivet wire and rod:
 - o · 1100
 - o · 2017
 - o · 2024
 - o · 2219
 - o · 3003
 - o · 5005
 - o · 5052
 - o · 5056
 - o · 6061
 - o · 7050
 - o · 7075
 - o · 7178
- ABS rules are not otherwise specific about the alloys to be used

Aluminum Design Manual

- Aluminum Design Manual of the Aluminum Association
 - Some adaptation of guidance needed for marine structures
 - Design manual intended for buildings and bridges
 - Allowable design stresses
 - Developed considering design loads and their probabilities of occurring
 - Fabrication practices for civil engineering structures
 - Different from ships and boats
- Two formats
 - Allowable stress design
 - Load and resistance factor design (LRFD)
 - Factors applied to loads separate from factors applied to allowable stress levels
 - Better correspondence to methods of design of marine structures
 - Marine not formally cast in a LRFD format

Aluminum Design Manual (Cont.)

- Riveted joint may fail in four ways
 - Elongation of the rivet hole
 - Shear rupture of the material between the holes
 - Fracture of the net section
 - Rivets may fail in shear
- Allowable stress design format
 - Factors of safety
 - 2.34 for fastener shear
 - 1.95 for the other modes of failure
 - Higher factor of safety for the rivets
 - Prone to errors occurring during fabrication
 - Over driving or under driving

Aluminum Design Manual (Cont.)

- LRFD format
 - o Design stress designated as ϕF_L
 - o Stresses from loads in accordance with the applicable building code or performance specification
 - o Marine loads consistent with this design formulation
 - Specified by a classification society
 - Determined through testing or hydrodynamic analysis
- Design bearing stress on rivets and bolts
 - o $\phi F_L = 2.0 \phi_U F_{TU}$,
 - o $\phi_U = 0.85$
 - o F_{TU} = ultimate tensile strength of the material that is joined by the rivet
 - o Assumes that center of rivet hole is distance s from the edge
 - $s \geq 2 \times$ fastener diameter, d
 - In no case less than $1.5 d$.
 - Intermediate cases spacing is between $1.5 d$ and $2.0 d$
 - Design stress is to be reduced by the ratio $s/2d$
 - Ensures that for a single rivet, the block shear strength equals or exceeds the bearing strength.

Aluminum Design Manual (Cont.)

- Minimum spacing of rivets is 3 times the rivet diameter
 - o Criterion was developed for compression members
 - o Components do not buckle between points of attachment
- Holes for rivets should be no more than 1.04 times the nominal diameter of the rivet
- Design bearing load on the rivet is the design bearing stress times the effective bearing area of the rivet
 - o Bearing area is the nominal hole diameter times the rivet's effective length
 - o Countersunk rivets: effective length = thickness of material minus one-half depth of countersink
- Design shear load on the rivet is the effective shear area of the rivet times the design stress for the rivet
 - o Effective shear area of the rivet is its cross-sectional area
- Design stress equals ϕF_{SU} , where $\phi = 0.65$ and F_{SU} is the minimum shear ultimate strength of the rivet, as given in Table 6-1.

Aluminum Design Manual (Cont.)

Table 6-1 Ultimate Shear Strength for Rivets

Alloy Designation Before Driving	Minimum Shear Ultimate Strength, F_{SU} ¹	
	MPa	ksi
2017-T4	225	33
2024-T42	255	37
2117-T4	180	26
2219-T6	205	30
5056-H32 ²	179	26
6053-T61	135	20
6061-T6	170	25
7050-T7	270	39
7075-T6	290	42
7075-T73	280	41
7178-T6	315	46

1. Unless otherwise indicated, from Aluminum Design Manual, with reference cited to ASTM B316.
2. From Czyryca and Vassilaros (1972). The strengths cited are average strengths, which have been decreased by 15 percent to obtain the minimum shear strength.

Aluminum Design Manual (Cont.)

- Commentary to the aluminum LRFD specification
 - o Derivation of the value of $\phi = 0.65$
 - o Computing equivalent factor from allowable stress design criteria
- Net section area for a member in tension
 - o Sum of the products of the thickness and the least net width of each element
- Net width for a chain of holes extending across a part in a diagonal or zigzag line
- Gross width minus the diameters of all of the holes
- Plus, for each gage space in the chain, the quantity $s^2/4g$, where:
 - o s = longitudinal center-to-center spacing (pitch) of any two consecutive holes.
 - o g = transverse center-to-center spacing (gage) between fastener gage lines.
- Net area, A_{net} is given by:

$$A_{net} = t \left(b - 2d + \frac{s^2}{4g} \right)$$

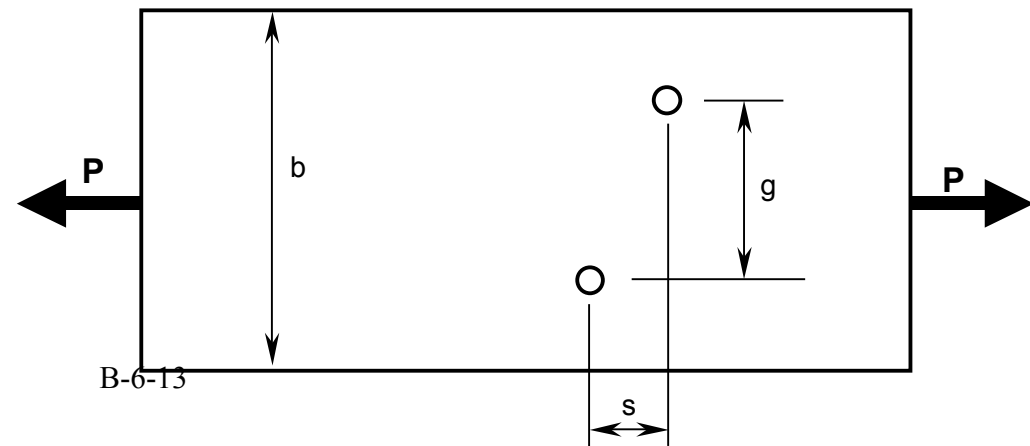

Aluminum Design Manual (Cont.)

- For angle
 - o Net width is found by flattening the section to find:

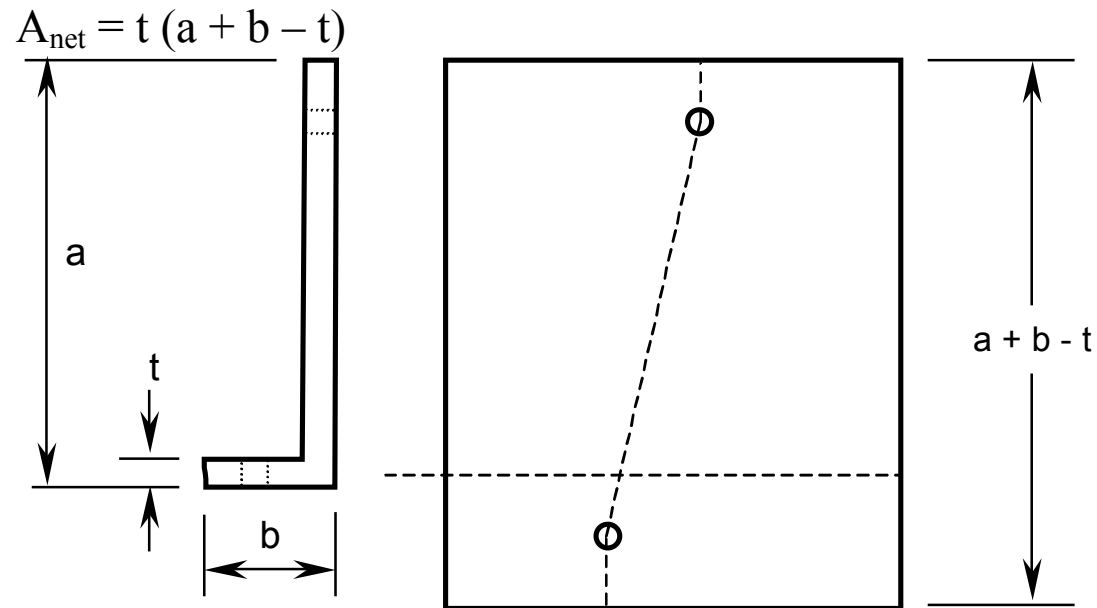
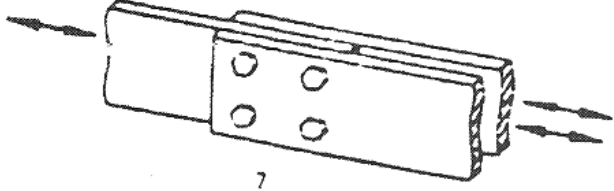
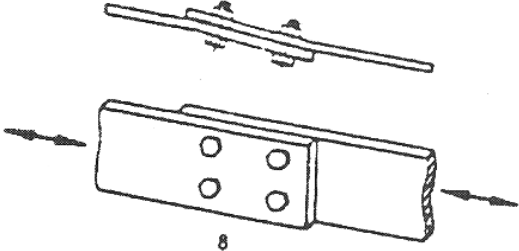

Figure 6-1 Angle in tension.

Fatigue of Riveted Joints

- Aluminum Design Manual
 - o Guidance for the fatigue of riveted joints
 - o Depends on the loading of the joint
 - o Ratio of the minimum stress to the maximum stress
 - o Compressive stresses are considered negative
- Fatigue classification used with Aluminum Association fatigue curves
 - o Explained in Chapter 9
- For symmetric riveted joint in alternating tension and compression
 - o Fatigue classification is Class B
 - o Equivalent to a butt weld
 - o Fatigue life = 2×10^6 cycles at a stress range of 44.9 MPa (6.5 ksi)
- Welded symmetric lapped weld
 - o Fatigue classification of E
 - o Fatigue life = 2×10^6 cycles at a stress range of 16.4 MPa (2.4 ksi)

Fatigue Classification of Riveted Joints (Aluminum Design Manual)

Joint Type	Load Ratio	Loading	Fatigue Classification
Symmetric (Detail 7) 	$R \leq 0$	Alternating tension and compression	B
	$0 < R < 0.5$	High mean stress, little variation, either fully tensile or fully compressive.	D
	$0.5 \leq R$	Low mean stress, much variation, either fully tensile or fully compressive.	E
Asymmetric (Detail 8) 	All ratios	All loading conditions.	E

Fatigue of Riveted Joints (Cont.)

- Study of Czyryca and Vassilaros (1972)
- Guidance for the fatigue design of riveted joints in aluminum
 - Fatigue failures usually occur at points of stress concentration
- Rivet holes are a frequent point of crack initiation
- Complex stress distribution
 - Cannot stress concentration factors to smooth specimen data
 - Cannot use fatigue data for specimens with notches or holes
- Data from fatigue testing of rivet joints is necessary
- 90 percent of the fatigue failures in mechanical joints occur at one of the outer holes
 - Remainder usually result of fretting near one of the outer, most highly loaded holes

Fatigue of Riveted Joints (Cont.)

Study of Czyryca and Vassilaros (Cont.)

- Studies of mechanical joints in aircraft structures
 - Applied to ship structures
- Variations in joint design more significant than changes in alloy used
- Joints of high static strength do not necessarily have high fatigue strength
- Fatigue strength of a joint increases with the number of fasteners used
 - Not in proportion to the static strength
- Multi-row lap joint, edge rivets carry the highest load
- As number of rivets increased
 - Fatigue strength is not increased proportionately
- The greatest fatigue strength is obtained with large diameter rivets placed close together and close to the edge of the structural member
 - Configuration that produces lower static strength
- Details such as poor rivet patterns, dimpling, countersinking degrade fatigue strength

Summary of Riveting

- Fabricating with rivets can reduce weight
 - Higher stress levels can be used
 - Weight reduction partially offset by weight of lap joints
- Riveted construction has less distortion than welded construction
- Cost of fabrication is greater
- Riveted joints have low fatigue strength
 - Unless joints are symmetric
 - Associated increase in weight
- Sealing compound is needed in welded seams to provide Watertightness
- The disadvantages generally outweigh advantages
 - Riveting is seldom used today in marine structures

Chapter 7

Joining Aluminum to Steel Structure

- Riveted Joints
 - o U.S. Navy started aluminum deckhouses for destroyers in 1936
 - Transversely framed with steel
 - Aluminum panels riveted to frames and to each other
 - Steel plate for armor protection
 - o Steel framing with aluminum and steel plate used by U.S. Navy for destroyer deckhouses until 1948
 - New destroyer leaders, the USS *Mitcher* (DL-2) Class in 1948
 - o Entirely welded aluminum deckhouses
 - o Transversely oriented frames
 - *Dealy* (DE-1008) Class started with steel deckhouses
 - o USS *Courtney* (DE 1021) in 1953 Aluminum deckhouse
- Until the mid-1980s, all new U.S. Navy combatant ships (destroyers, destroyer escorts, frigates and cruisers) had aluminum for the majority of their deckhouses
 - Aluminum deckhouses in landing ships
 - Islands of some aircraft carriers and amphibious assault ships

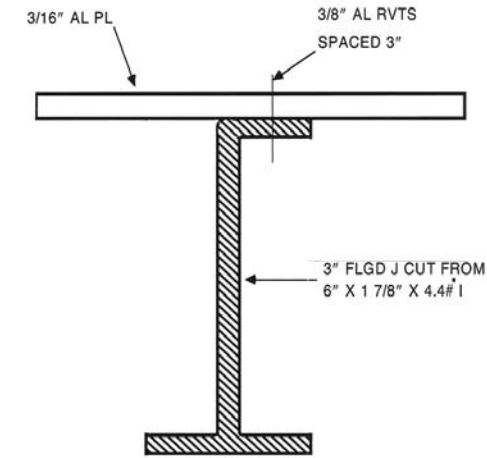

Destroyer Deckhouses (Cont.)

- Hulls of steel
 - Mechanical connection between steel and aluminum
 - Insulating material between the two metals
 - Avoid galvanic corrosion
 - Rubber electrical tape used
 - Joint absorbs moisture
 - Alternate drying and wetting with seawater
 - Concentration of salt deposits builds up
 - Any breakdown of the insulation
 - Points of stress concentration
 - Rapid corrosion
 - Problem exacerbated by exfoliation of plate.

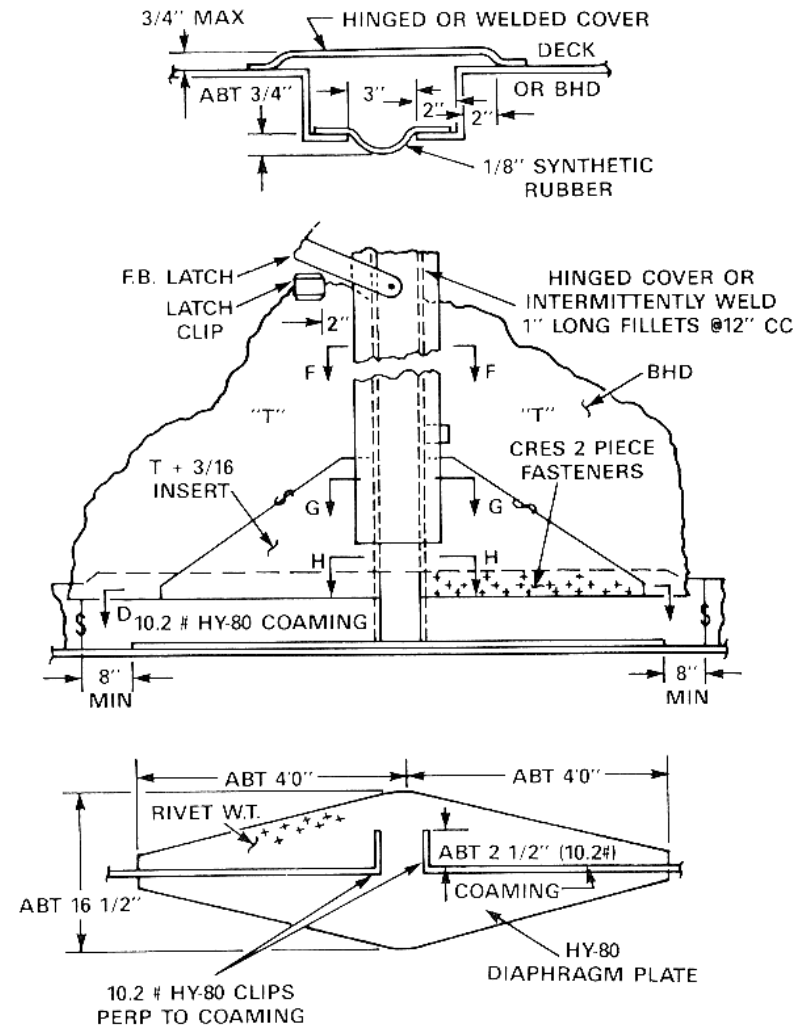

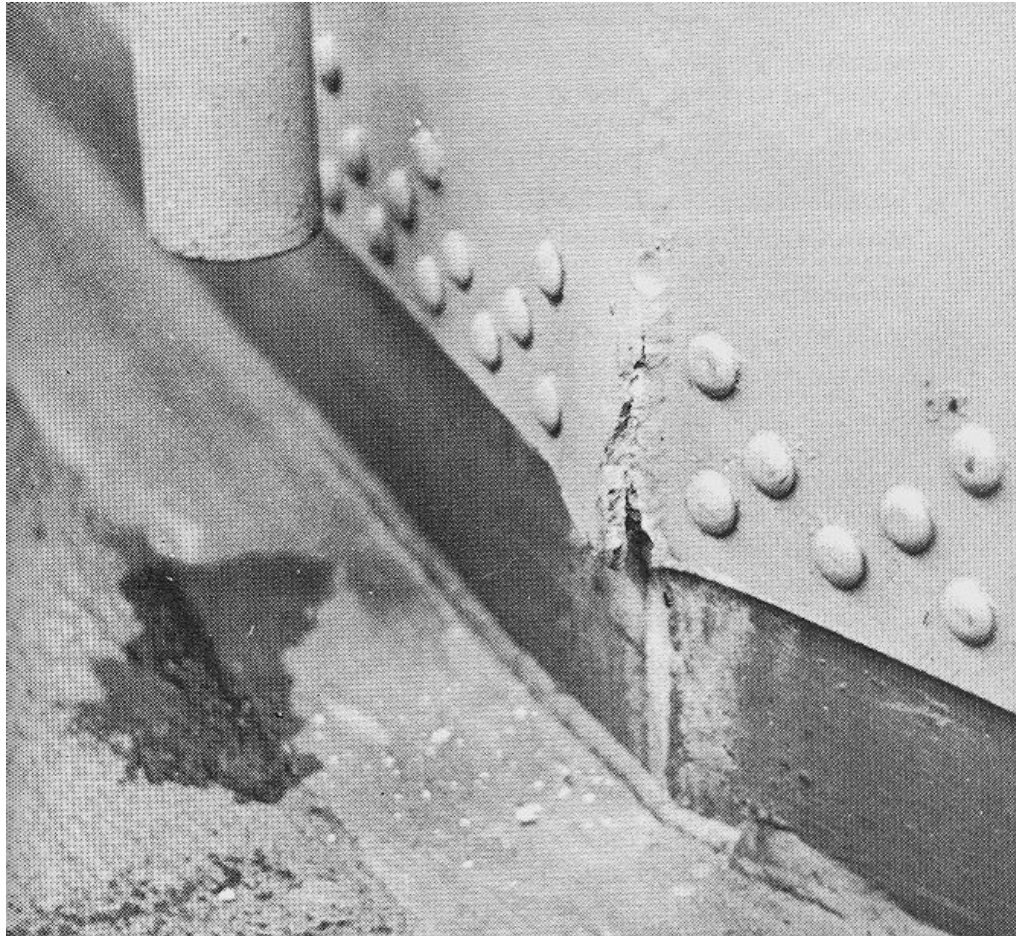

**Riveted connection with corrosion in the aluminum
(Dye and Dawson, 1974)**

Bimetallic Joints

- Developed in the mid-1960s
 - Actually a trimetallic joint
 - Two different grades of aluminum used
- First joints had 6.35-mm (0.25-inch) layer of 5456 aluminum
 - Bonded to a 9.53-mm (0.375-inch) layer of 1100 aluminum
 - Bonded to 19.05-mm (0.75-inch) layer of A516 Grade 55 steel
- Initially used explosive bonding
 - Some manufacturers use roll bonding today

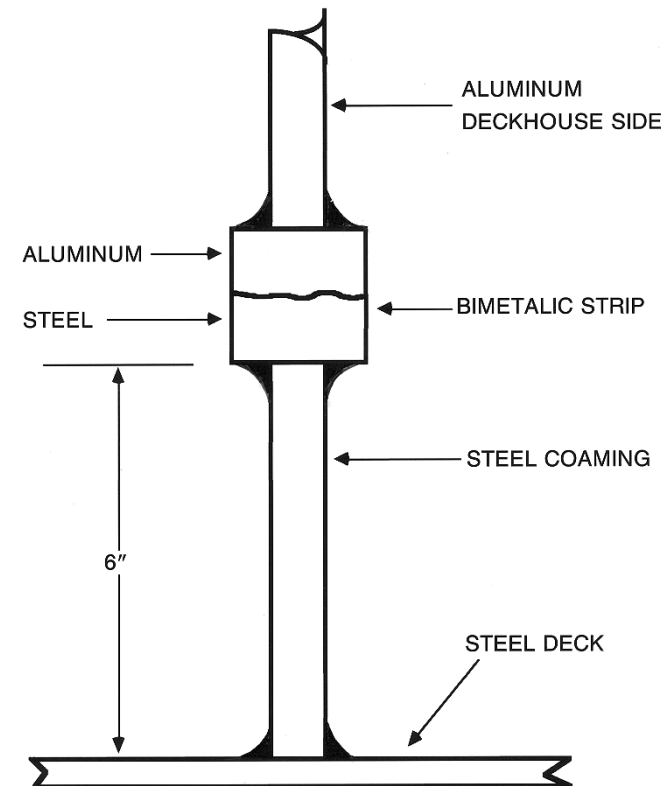

Bimetallic Joints (Cont.)

- Bimetallic joint works because it is a clean bond
 - o Does not trap moisture
 - o Can be preserved with the proper coatings
- Corrosion tests
 - o Performed in the late 1960s by E.I du Pont de Nemours Co.
 - o Uncoated samples
 - o Spray zone Wrightsville Beach, North Carolina
 - o 12 and 27 months

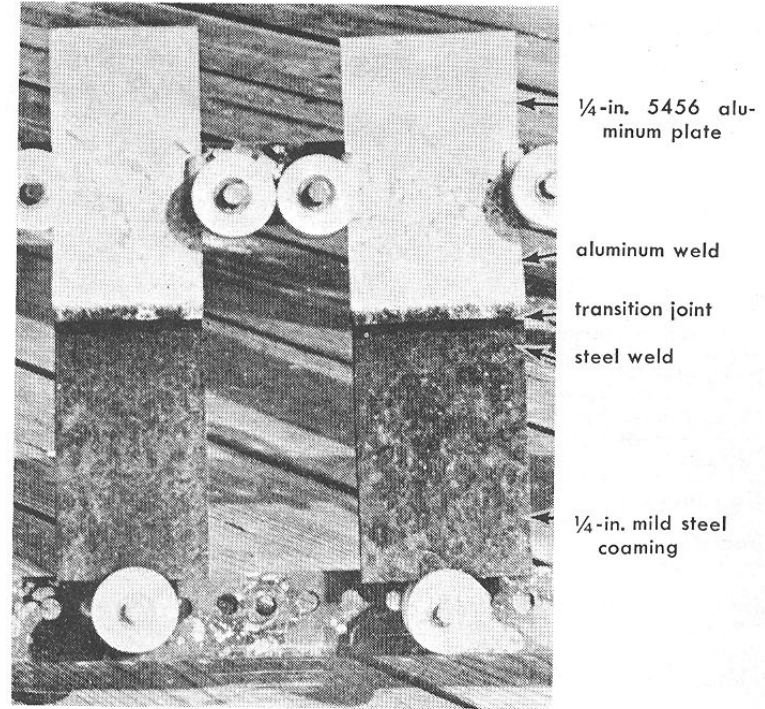

Bimetallic Joints (Cont.)

- Results of corrosion tests very favorable
 - Microscopic examination of test samples
 - Slight penetration where corrosion begins
 - Area quickly fills with hydrated aluminum oxide corrosion product
 - Occupies larger volume than aluminum consumed
 - Seals aluminum-steel interface
- Moderately good corrosion resistance
- Should still be preserved
- Never use immersed in seawater
- Where standing seawater can accumulate
 - Corrosion will occur on aluminum
 - Bimetallic joint corrodes little

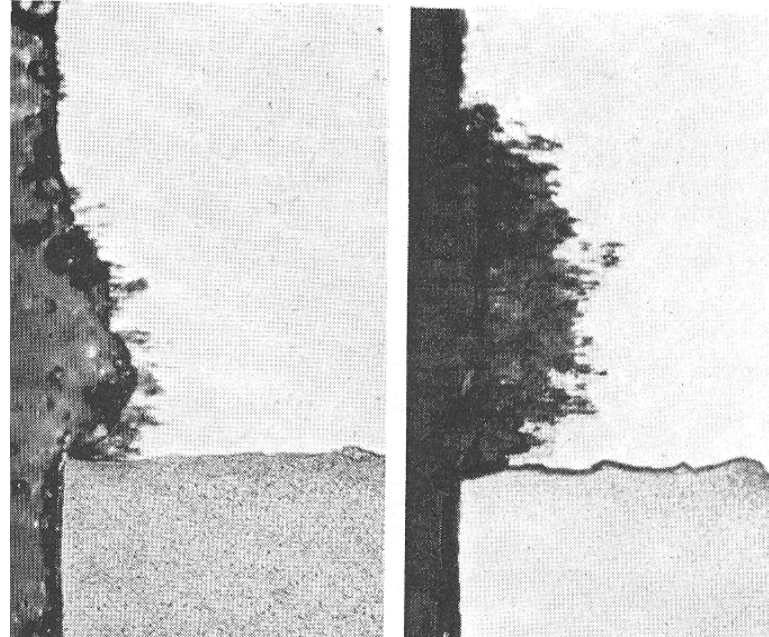

Bimetallic Joints (Cont.)

- Initial test of strength of bond (McKenney and Banker, 1971)
 - Ram forced through a hole bored into the joint
 - Weakest area of joint in 1100 aluminum
 - Samples tested after welding
 - Ultimate tensile strength of 93 MPa (13.5 ksi)
- 25.4-mm (1-inch) wide strip tested
 - 6.35-mm (0.25-in) plate of 5456 aluminum welded on one side
 - 6.35-mm (0.25-in) plate of mild steel on other side
 - Failure in tension in the heat affected zone of the 5456 plate
 - Ultimate strength of 356 MPa (51.6 ksi)
 - Strength greater than nominal 290 MPa (42 ksi) ultimate strength of welded 5456-H116
 - Greater than specified 317 MPa (46 ksi) ultimate strength of base metal
 - Perhaps restraint from thick bimetallic strip increased the strength of the joint
- Recommended bimetallic strip should be four times wider than the thickness of the plates being joined

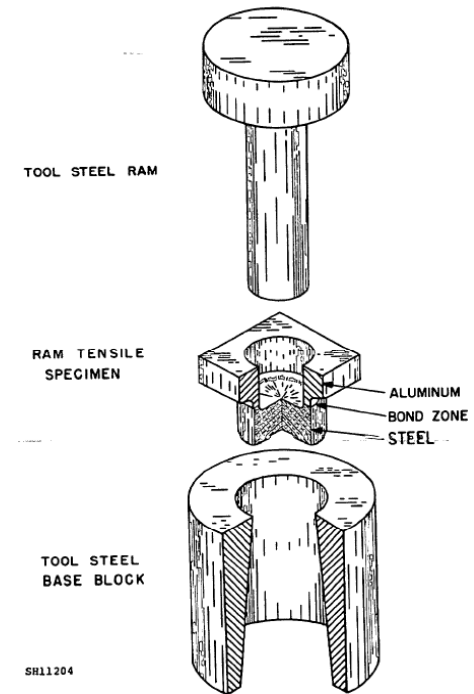

Bimetallic Joints (Cont.)

- Fatigue Strength
 - U.S. Navy MIL-J-24445
 - Issued for the material in 1971
 - Last revised in 1977
- Specification requires fatigue testing
 - Specified minima
 - Consider as the lower limit probability values
- Equivalent to
 - Aluminum Association Class B
 - Eurocode 9 class 69-7 S-N curve

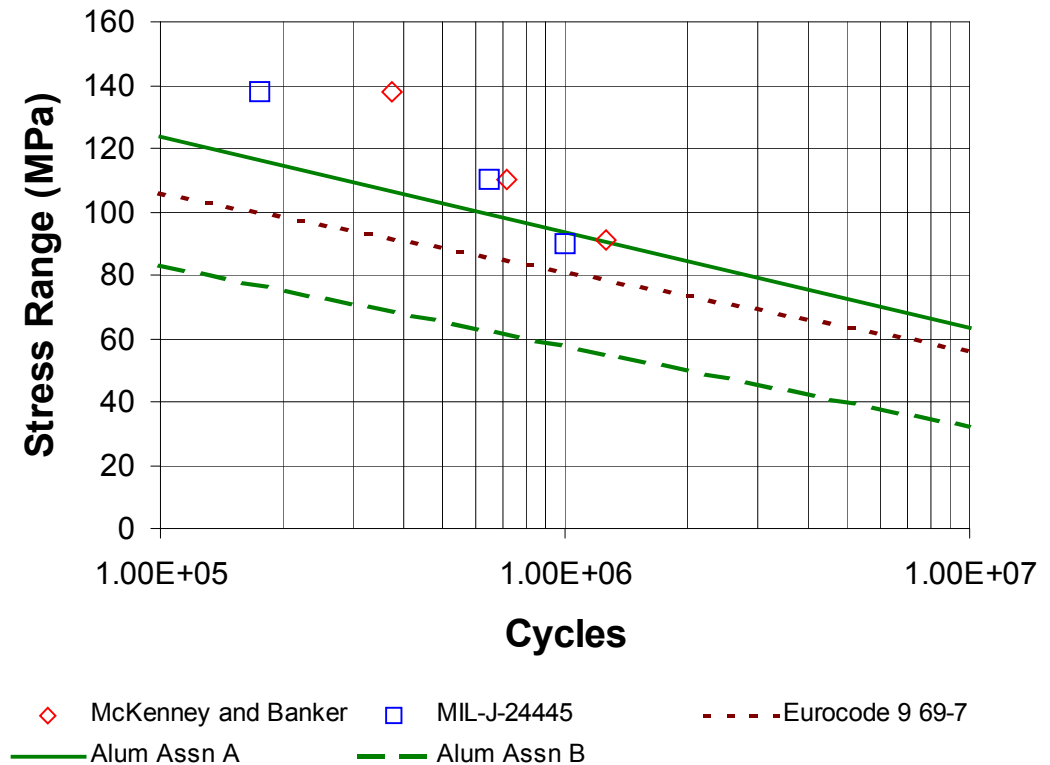

• Bimetallic Joints (Cont.)

Fashion plates at ends of deckhouse

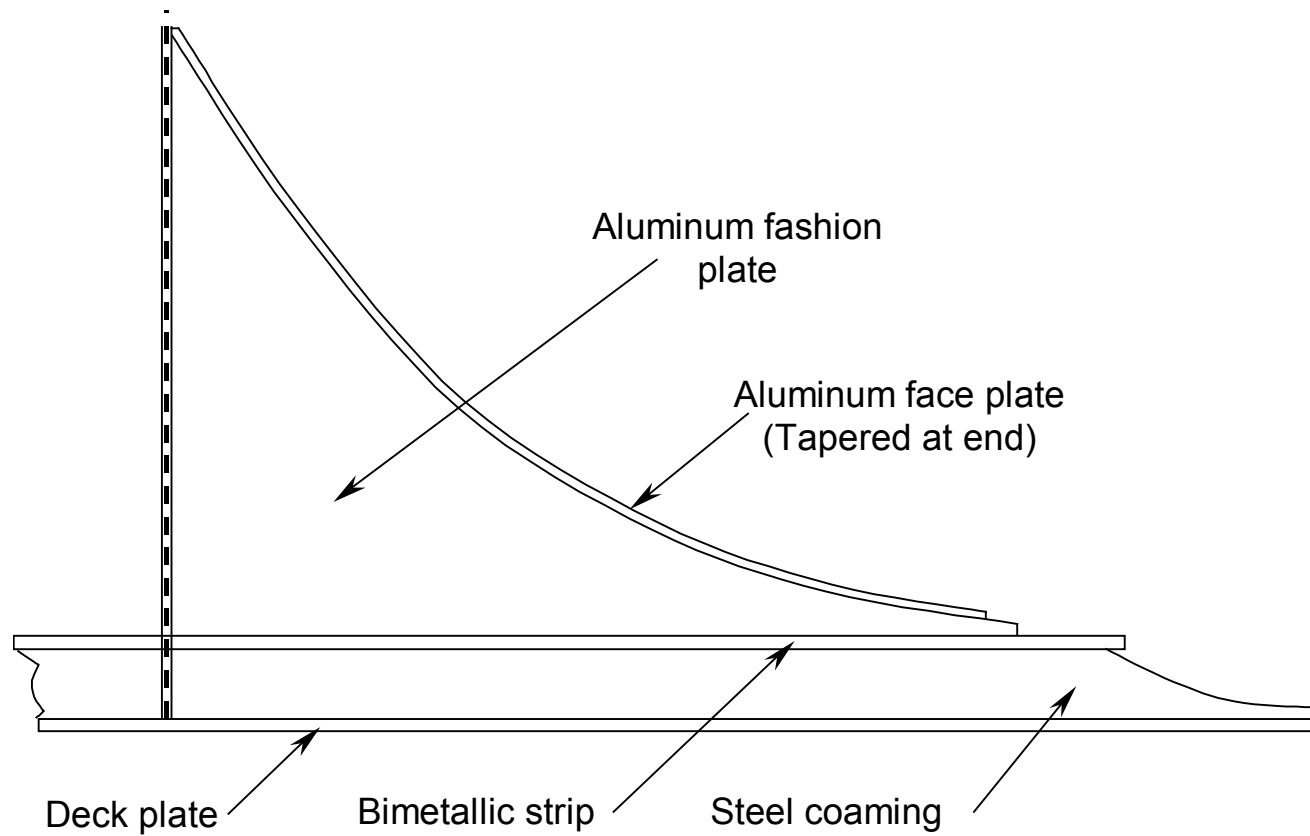

Expansion Joints

- Cracking frequently occurs at the base of expansion joints
 - Introduce more problems than they solve
- Maintenance of rubber weatherproof strip
 - Poor cleanliness for collective protection system
- Better to use finite element analysis
 - Ensure that continuous deckhouse has acceptable stress levels

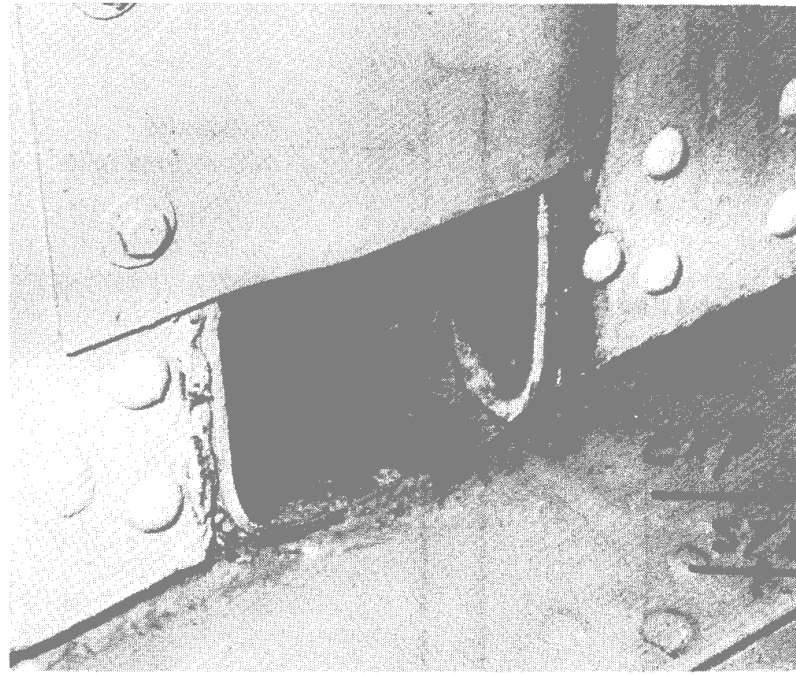
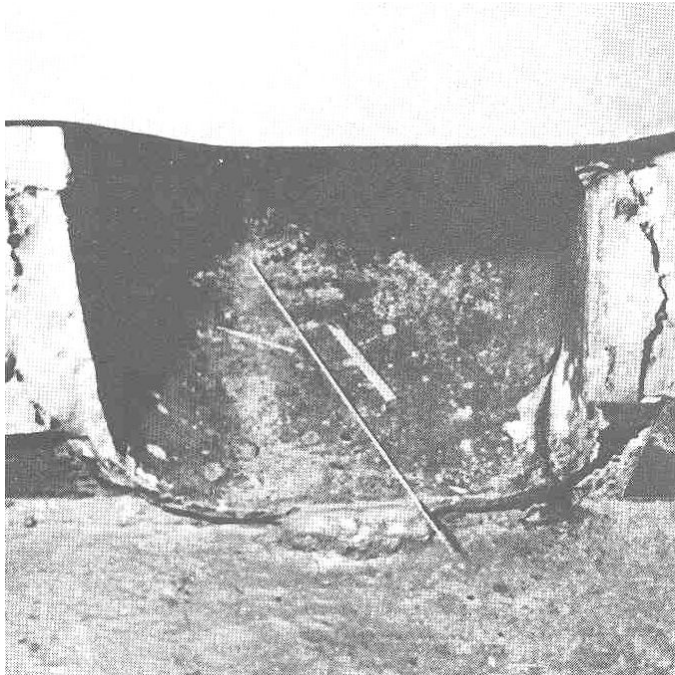

Isolation of the Deckhouse from the Hull

- Deckhouse completely isolated from the hull
 - Heavy-duty shock mounts
- Reduces transmission of noise and vibration
 - Increases passenger comfort
- Reduces stress in deckhouse
 - Eliminates hull girder bending stresses in deckhouse



Summary of Joining to Steel Structure

- Electrical separation of aluminum deckhouse from steel hull necessary
 - Prevents galvanic corrosion
- Riveted connections with insulation not effective in the past
 - When insulation breaks down
 - Galvanic corrosion begins immediately
- Bonded bimetallic steel and aluminum strip
 - Welded between steel coaming and aluminum deckhouse
 - Provides a smooth surface
 - Can be coated to prevent corrosion
- Stresses acting in deckhouses could only be roughly estimated in the past
 - Problems in junction between and aluminum deckhouse and steel hull
 - Fatigue failures in the deckhouse
- Finite element methods useful today
- Complete isolation of the deckhouse from hull
 - Another solution to the interface problem
 - Can reduce vibration and noise in the deckhouse.

Chapter 8

Residual Stresses and Distortion

- Comparison of aluminum to steel
 - Elastic modulus of aluminum is one-third that of steel
 - Coefficient of thermal expansion is about twice as much
 - Strains from cooling of welds and surrounding areas produce lower residual stress
 - Reduced elastic modulus
 - When residual stresses do occur
 - Tend to produce greater distortion than in steel structure
 - Buckling of plating
 - Aluminum conducts heat anywhere from 2.5 to 9 times faster than steel
 - Area heated during welding processes is greater
 - Not as intense
- Aluminum structure tends to distort more during welding
- Tolerances for ship construction reflect this

Distortion from Other than Welding

-
- Mill tolerances
 - Structural Shapes
 - The Aluminum Association
 - Camber and sweep 0.0042 times the length
 - An 8-meter extrusion (24-foot) can have 33 millimeters of distortion (1.3 inches)
 - ASTM Standard A6 (steel)
 - Camber and sweep for rolled steel shapes 0.001 times length
 - 0.01 times length for sections with a flange width of greater than 6 inches
 - An 8-meter long steel shape with a flange width greater than 6 inches
 - Allowable distortion of 8.3 mm (0.33 inches)
 - One-fourth of the allowable for aluminum
- Plates
 - Aluminum
 - Plate 6.4 mm (0.25-inch) thick 1.83 m (6 feet) wide
 - Flatness tolerance of 13 mm (0.5 inches)
 - Same size carbon-steel plate: flatness tolerance = 24 mm (0.94 inches)
 - High-strength low-alloy and alloy steel plates = 35 mm (1.38 inches)
 - Carbon steel plate allowable distortion 1.8 times greater than aluminum plate

Distortion from Other than Welding (Cont.)

- Weld distorted shapes to uneven plate
 - Residual stresses will remain after fabrication
 - Contribute to the overall distortion of the panel.
- Straightening operations at the mill
 - Counteract the residual stress patterns from initial forming of the plate or shape
 - Apparently straight or flat shape or plate will have locked in stresses
 - Can be released by cutting operations, and new sets of distortions will result.
- Adjustments to align assemblies
 - Forcing them together
 - Produces residual stresses
 - Can lead to distortions of combined structure
 - Overall distortion of the hull
- Thermal distortions during fabrication if exposed to sun
- Flame straightening
 - Build in overall residual stresses
 - Greater distortions of the entire structure

Welding Distortion

Generally less distortion at an aluminum weld than same size weld in steel

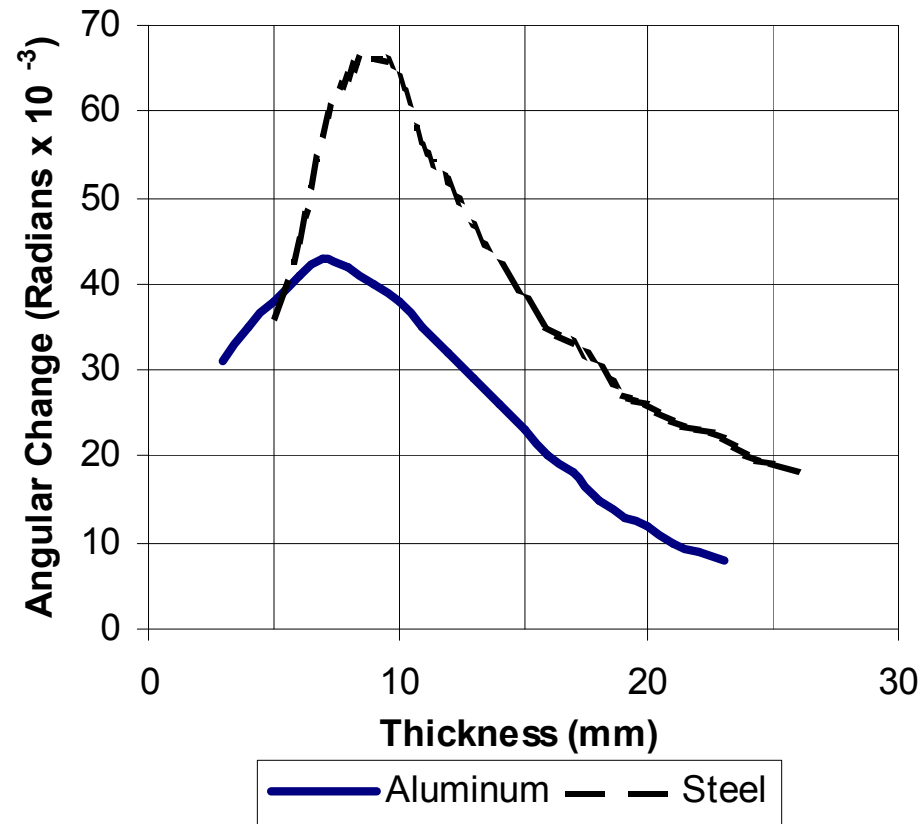

Comparison of distortion at a fillet weld (Masubuchi, 1990)

Patterns of Welding Distortion



Transverse shrinkage

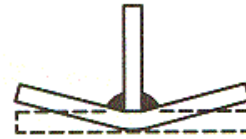

Angular change

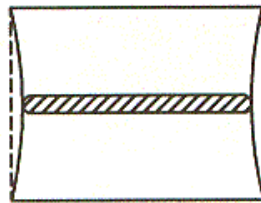

Longitudinal shrinkage

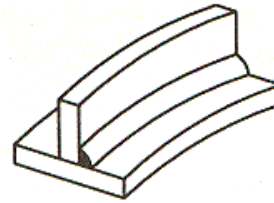

Longitudinal bending distortion

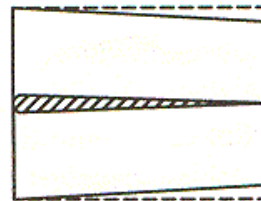

Rotational distortion

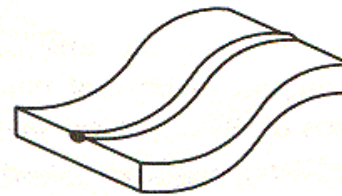

Buckling distortion

Six types of distortion identified by Masubuchi

Reduction of Welding Distortion

- Distortion from buckling of plate
 - Caused by residual stress
 - Increase plate thickness or decrease stiffener spacing
- Study by Conrardy and Dull (1997) for steel
 - Egg-crate or stick construction
 - Longitudinals and stiffeners are welded together first
 - Distortion reduced by 50 percent
 - Conjunction with pre-heating the center of the plate prior to welding
 - Tensioning the plate prior to welding
 - Impractical to implement with ship-sized panels
 - Thermal tensioning of weld zone to pretension plate
 - Resistance heaters heated plate
 - Water spray used to cool plate on opposite side from double fillet weld
 - Maintaining a 170 °C temperature differential
 - Eliminated the buckling distortion
 - Significant angular distortion

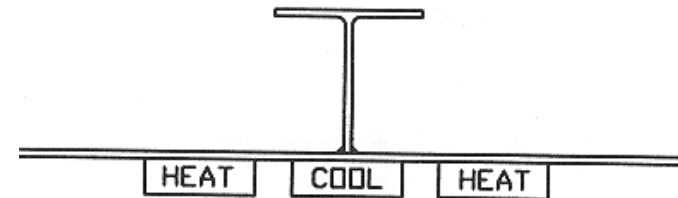

Reduction of Welding Distortion (Cont.)

- Conrardy and Dull study on steel (cont.)
 - Quenching weld with water spray on back side of fillet weld
 - Very effective in reducing both buckling distortion and angular distortion
 - Technique can have adverse effect on the metallurgical properties
- Other methods
 - Apply restraint during welding
 - Reduce distortion because rigidity forces weld yield during cooling
 - Back bending of plate prior to welding
 - Requires experimentation to determine amount of back bending required
 - Suitable only for longitudinal welds
 - Back side line-heating of steel panels
 - Straighten panels after welding
 - Induces buckling distortion thin panels.

Reduction of Welding Distortion (Cont.)

Study by Deo and Michaleris (2002) built-up steel tee sections

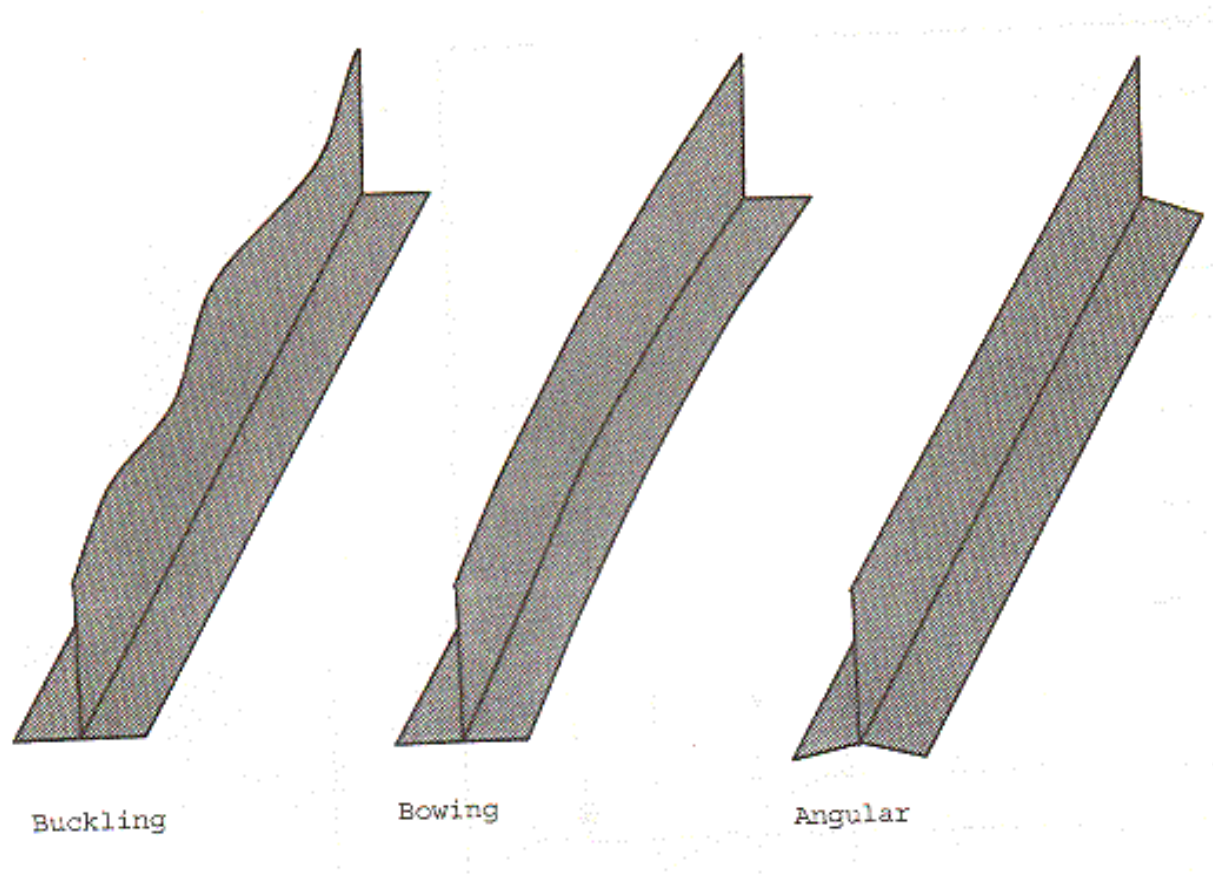

Analysis of Residual Stress in Weld

(Seo and Jang, 1999)

$$f_x = E_{ix} \left[\alpha T_{c(x)} + \frac{\sigma_{yx}}{E_{ix}} + \frac{\sigma_{yx} t}{k_x b} \right] \frac{\pi}{4} d$$

$$k_x = E [(t - d) / t^2]$$

For 6.4 mm aluminum plate

$$T_{cx} = \frac{Q \eta}{c \rho b_m} = \frac{1075 \times 1.0}{215 \times 2.66 \times 10^{-3} \times 14.4 \times 0.64} = 204^\circ\text{C}$$

For 6.4 mm mild steel plate, $T_{cx} = 724^\circ\text{C}$

η = heat conduction factor, which can be taken as 1.0 for flat plate

c = 215 calories/kg-°C for 5083-0 and 100 calories/kg-°C for mild steel.

ρ = density, = 2.66×10^{-3} kg/cm³ for and 7.85×10^{-3} kg/cm³ for mild steel.

b_m = 5 times the plate thickness for steel, = $5 \times 156/54 = 14.4$ times plate thickness for aluminum

For aluminum, $f_x = 123$ N / mm

For steel, $f_{x \text{ steel}} = 477$ N/mm

$$f_{x \text{ (aluminum)}} / f_{x \text{ (steel)}} = 123 / 477 = 0.26$$

Residual stress in welded aluminum structure one-fourth those of welded steel structures

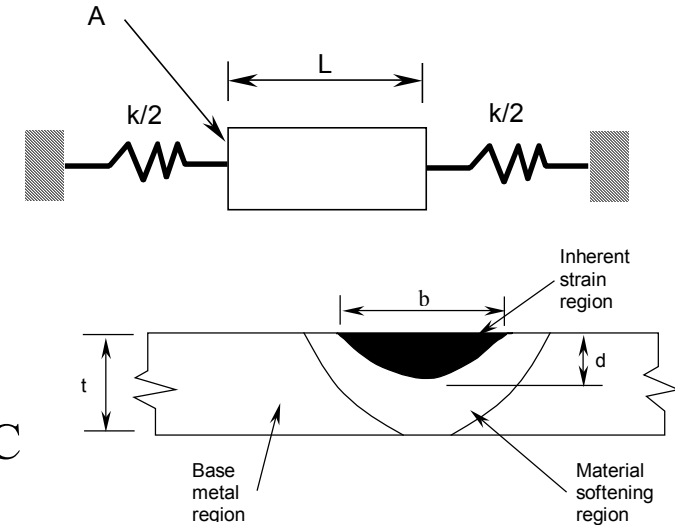

Analysis of Aluminum Welding

Tsai et al. (1999)

- Effect of welding sequence on aluminum panel distortion
- Developed joint rigidity method
- Determine optimum welding sequence for minimum distortion
- Inherent shrinkage method used
- Structure in detailed finite element model
 - Weld metal cools from 649 °C (1,200 °F)
 - Properties of metal changed incrementally
- Analysis and experimental butt weld
 - Two 600 mm x 275 mm plates of 10 mm 5083 aluminum
 - Calibration factor developed (not described)
 - Calibration factor used in subsequent analyses

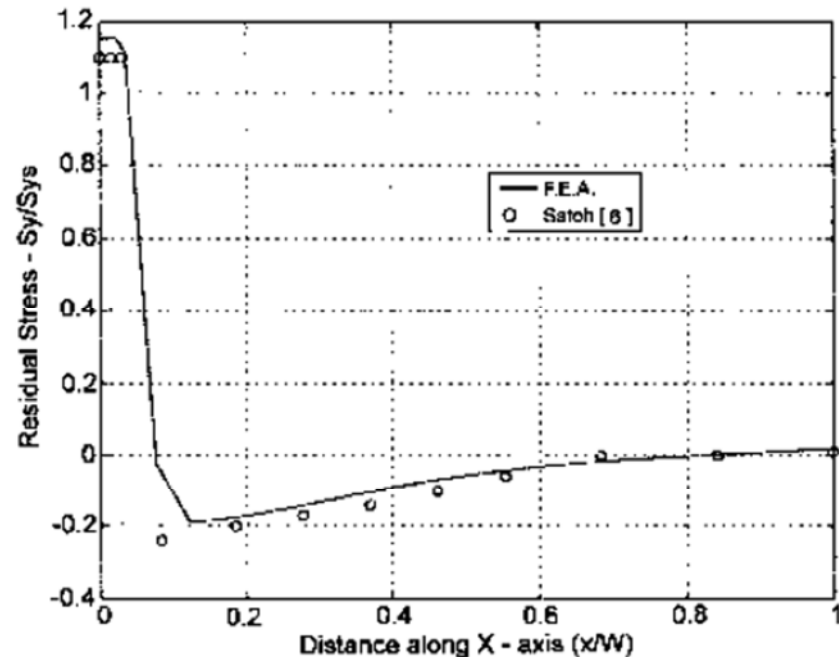

Tsai et al. Analysis of Aluminum Welding (Cont.)

6.4-mm (0.25-in) plate of 5454-H34 aluminum
Fillet welded to another plate of the same thickness
Inherent shrinkage method used

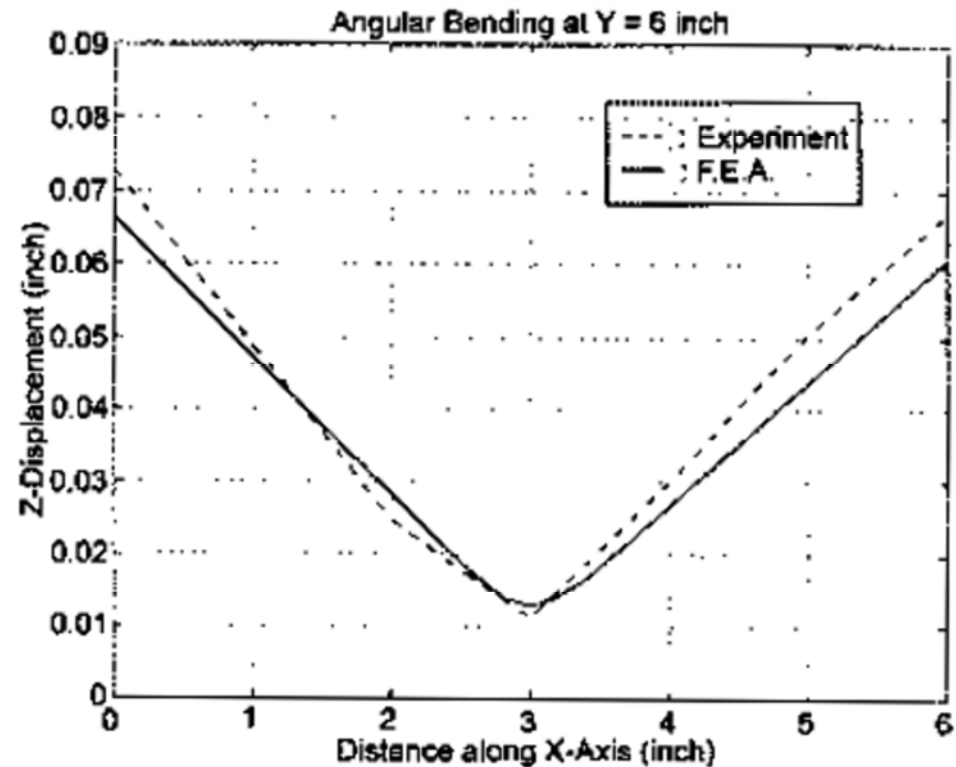

Tsai et al. Analysis of Aluminum Welding (Cont.)

- Determine optimum welding sequence on panel for minimum distortion
 - Weld from areas with highest restraint
 - To areas with the least restraint
- Joint rigidity = ratio of moment applied at a joint to resulting rotation

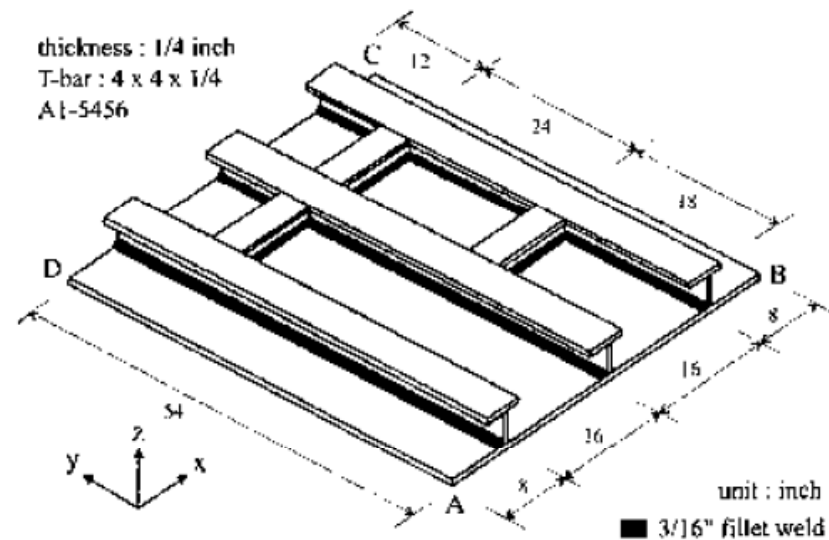
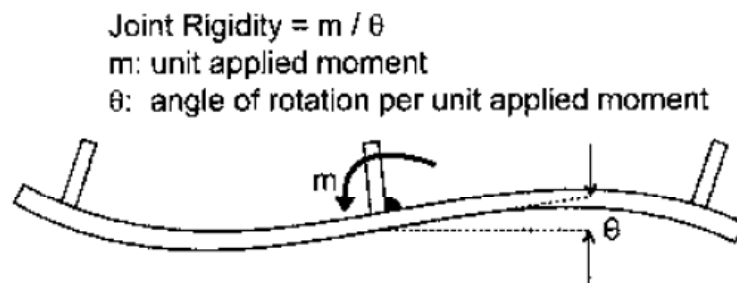

Tsai et al. Analysis of Aluminum Welding (Cont.)

Panels welded in four different sequences

1. Welding progresses from the inner panels outward
2. Welding progresses from the from outer panels inward
3. Similar to 1 with consideration of changing structural rigidity of each joint
4. Similar to 3 with consideration of changing structural rigidity of each joint

Sequence 3 searches for the joint with highest restraint to deposit the next weld as the assembly process progresses. Sequence 4 lays the next weld at the least restrained joint

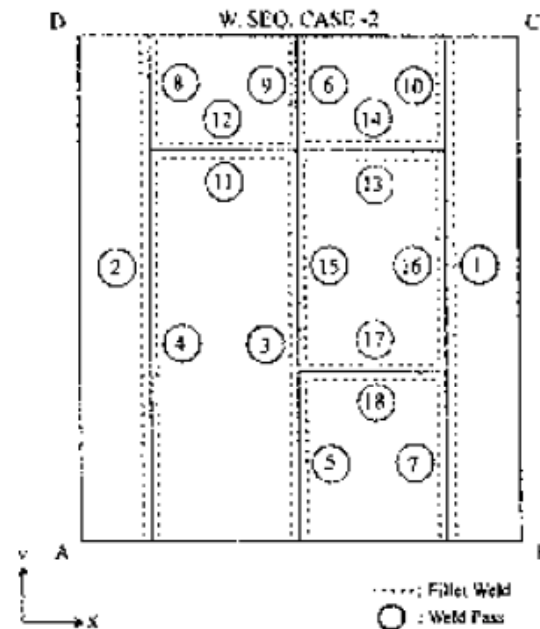
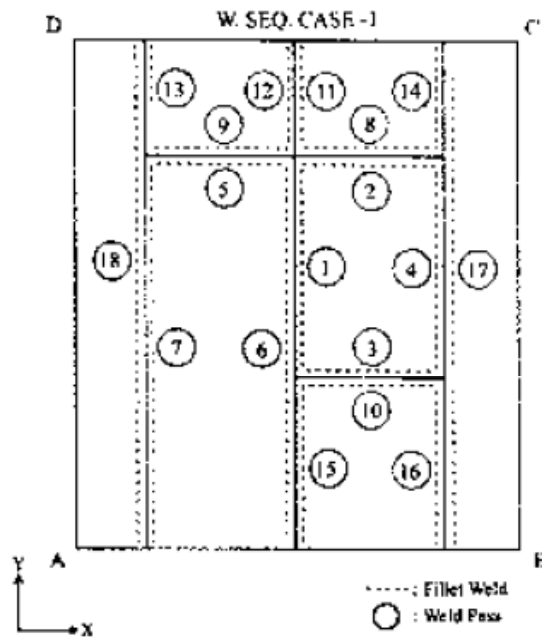

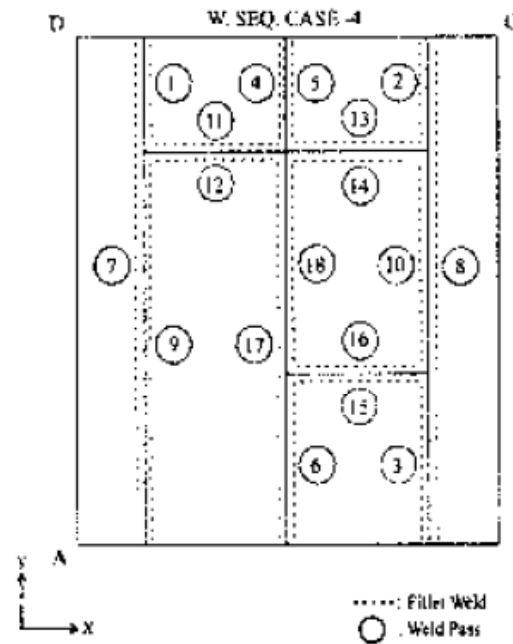
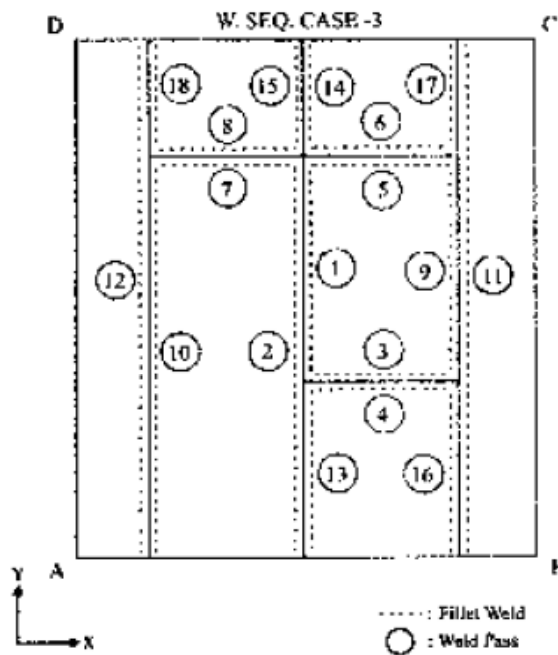

- Resulting distortions measured
 - Sequences 2 and 4 showing the most distortion
- Comparison of experimental and measured distortions
 - Welding sequence 4

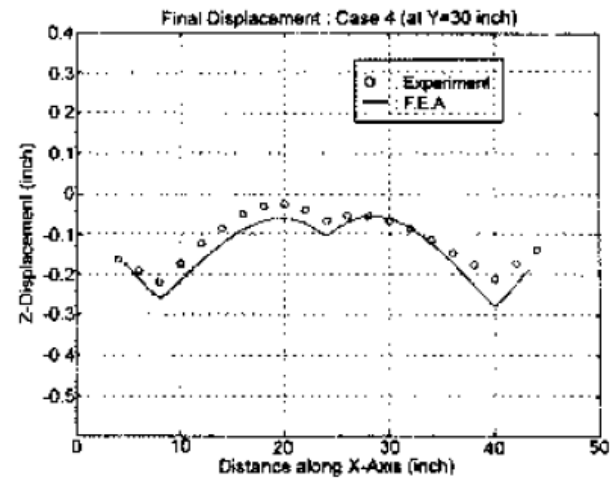
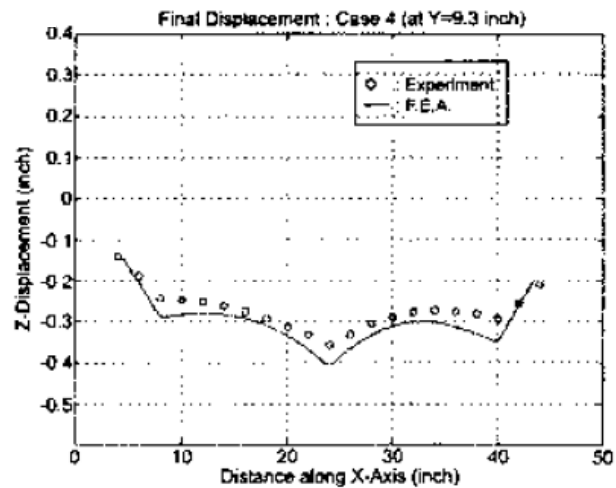
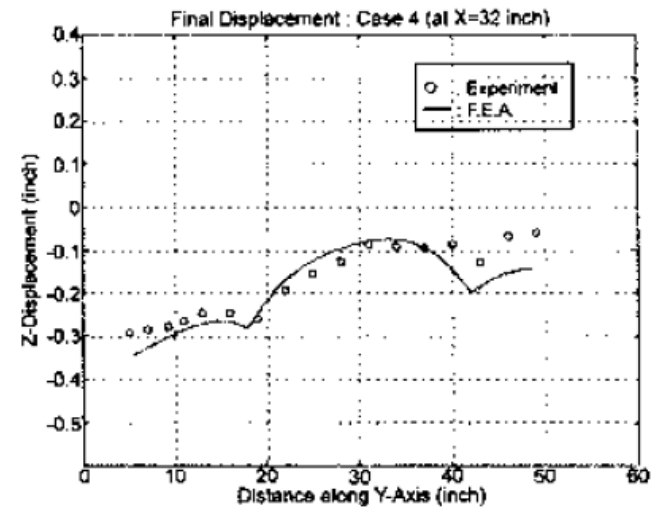
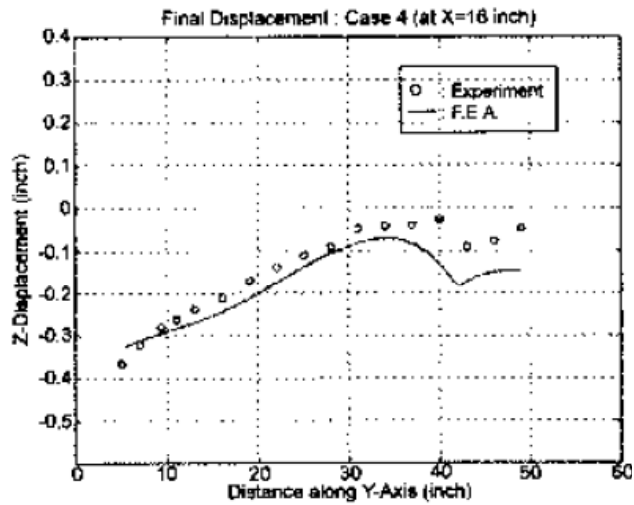

**Comparison of experiment and analysis of sequence 4 of panels
(Tsai et al., 1999)**

Tsai et al. Analysis of Aluminum Welding (Cont.)

- Joint rigidity method used to analyze the panel
 - After each welding operation
- Determine a weld sequence that would result in the least distortion

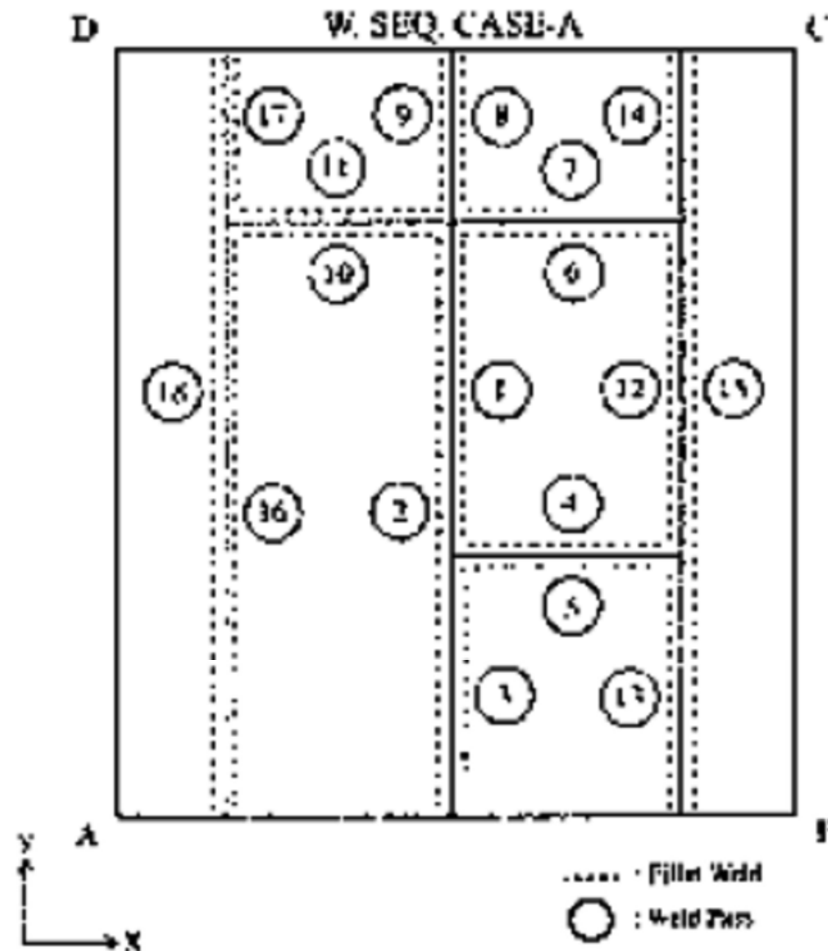

Reduction of Welding Distortion

- Guide for Aluminum Hull Welding (AWS, 2004)
 - o Sequence that is similar to that found analytically by Tsai et al.

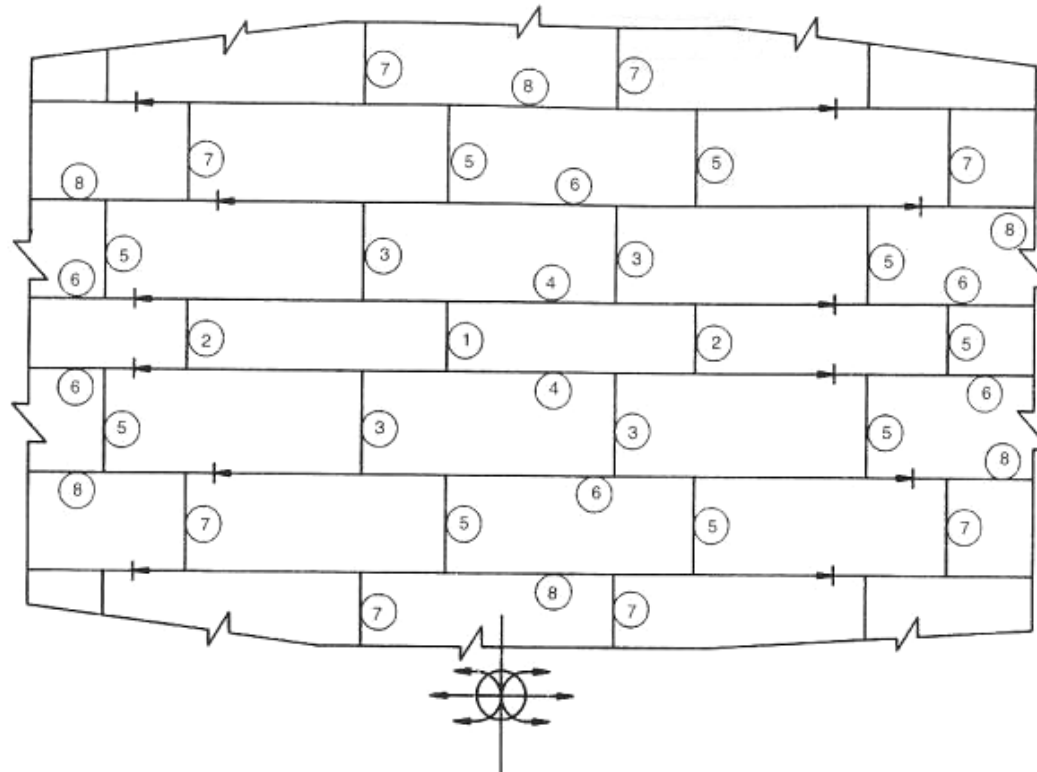

Reduction of Welding Distortion (Cont.)

AWS hull welding guide makes the following recommendations:

1. In large panels consisting of a number of plates, the butt seams should be welded before the panel seams. In that way, the shrinkage caused by the many smaller joints has taken place prior to final alignment and welding of the long panel seams.
2. Welding of panels constructed of multiple plates should progress from the center toward the outer edges.
3. Starting at the center of a seam and welding outward with a backstep sequence has proven helpful in specific instances.

Distortion in Panel Fabrication

- Distortion in shipbuilding is cumulative
- Distortions occurring at one stage of construction carried over to the next
 - Correcting distortion and misalignment at an early stage
 - Less distortions in latter stages of construction
- **Welded Panels**
- Specialized panel lines
 - Repetitive fabrication of similar panels
 - compensation can be made for welding distortion
- Japanese Technology (Suzuki et al., 2005)
- Study using automatic GMAW fillet welding
 - Typical panels 2.15 m long
 - 11.0 meters wide
 - Plate between 3 and 25 mm
 - Stiffeners range in depth from 40 to 190 mm
 - Minimum stiffener spacing 220 mm.
- Preheating used to reduce angular distortion at the fillet welds
 - Plate and stiffeners preheated homogeneously in a furnace
 - Removed for welding

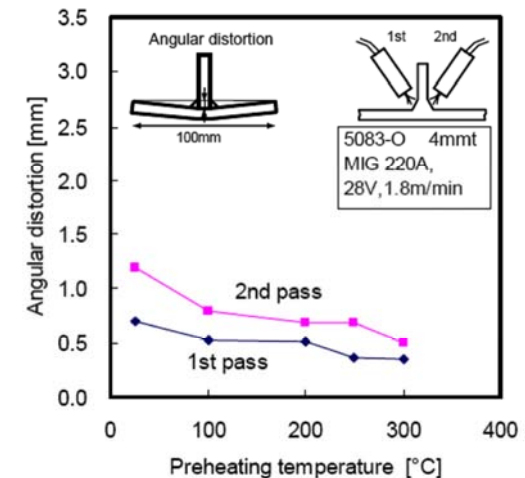

Study by Suzuki et al. (Cont.)

- Moving panels into and out of oven cumbersome
 - Failed to remove sufficiently the angular distortion
 - Different method tried
- In-line preheating immediately before the fillet welds

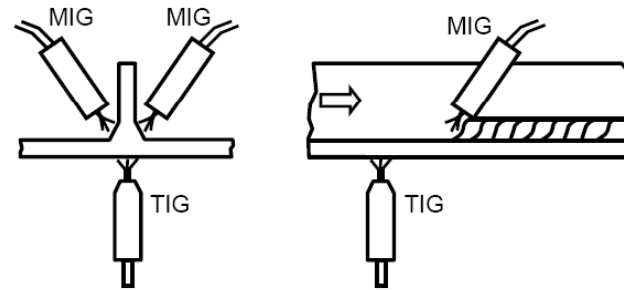

With in-line TIG preheating



Without preheating



Study by Suzuki et al. (Cont.)

- Plate preheated so will be 100°C at fillet welding position
 - Preheating torch 150 mm and 5 seconds before fillet welding
- In-line preheating has two benefits
 - Heating plate reduces angular distortion
 - Having in-line preheating on the opposite side of the plate from the fillet welds induces a reverse angular distortion
- Effect of distance of preheating torch from fillet welding process
 - 40-mm bulb flats with 3-mm webs welded to 4-mm plate
 - angular distortion reduced sufficiently with preheating 50 and 300 mm ahead
- Separate preheating or post-heating not as effective

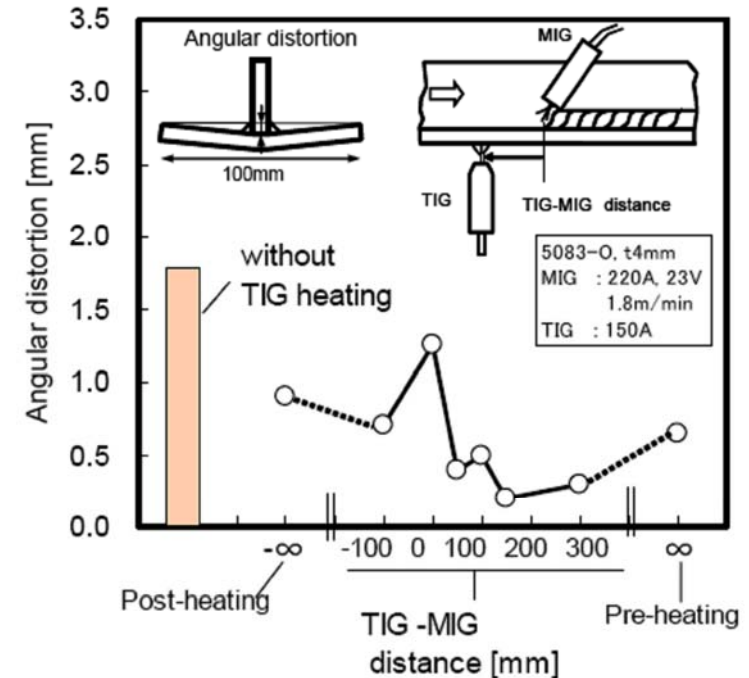

Study by Suzuki et al. (Cont.)

- Longitudinally stretching panels after welding
 - Longitudinal stretching of 0.05 percent
 - Reduces distortion for panels with 4-mm and 6-mm-thick plates
 - Similar to stretching process used to straighten extrusions

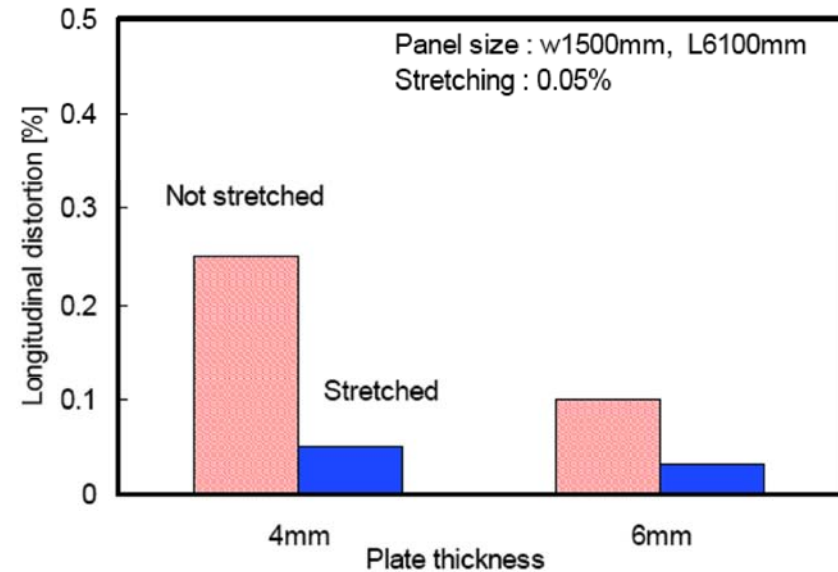

Study by Suzuki et al. (Cont.)

- Longitudinal stretching of panels after welding longitudinal stiffeners
 - Helps panel maintain flatness after subsequent welding operations

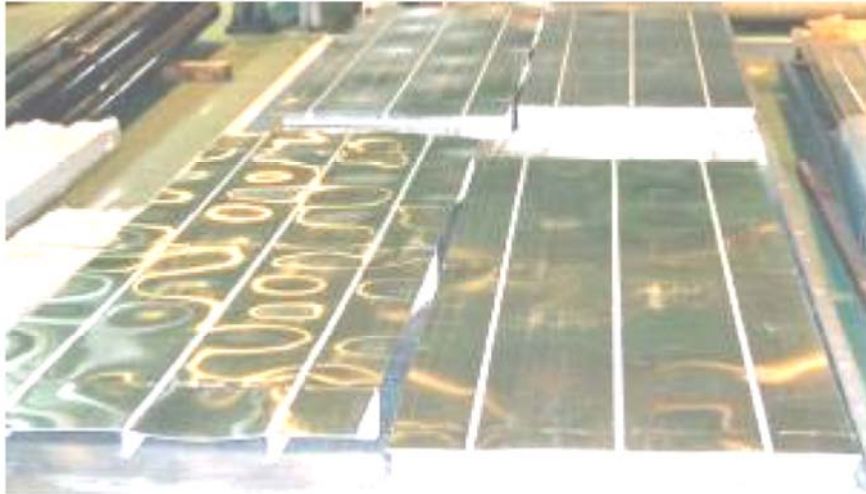

Not Stretched

Stretched

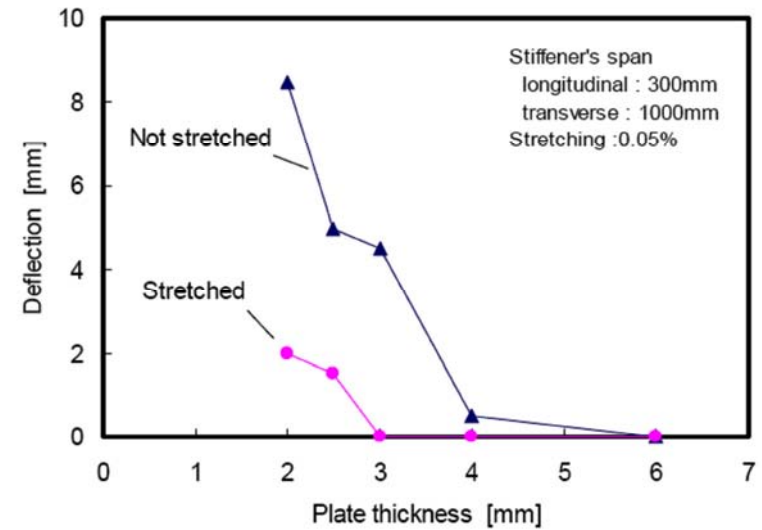

Extruded Panels

- Welding distortion studied by Seo et al. (1999)
 - o Extruded panels are initially flat
 - o Two panels are butt welded together
 - o Distortion similar to welding plates together

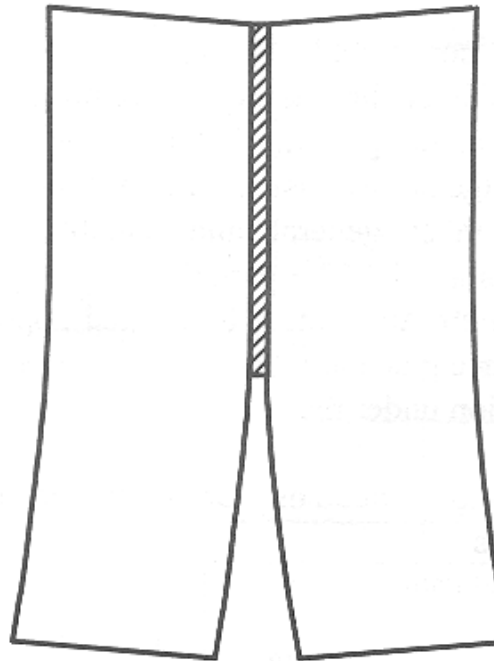

Study by Seo et al. (Cont.)

- Holding panels in a jig
 - o Strongback used to reduce transverse distortion
 - o Curvature can still result

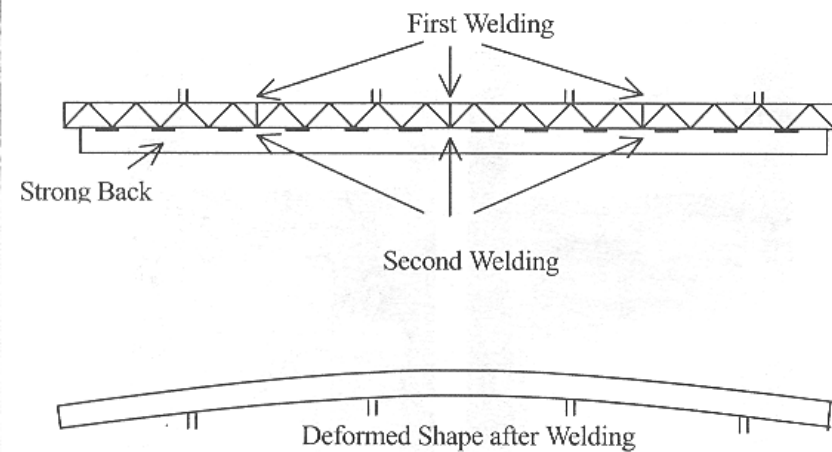
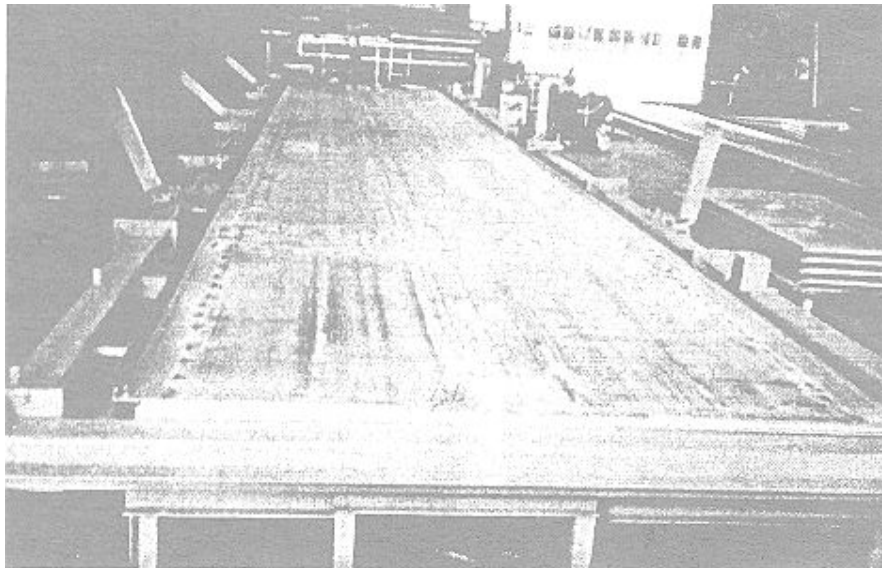

Tolerances in Welded Aluminum Structures

- International Association of Classification Societies
 - Fabrication tolerances for steel ship but not for aluminum
- ABS requirements for aluminum similar to U.S. Navy
- U.S. Navy Military Standard 1689 (MIL-STD 1689)
 - Same structural tolerances aluminum structure as for steel
 - Except requirements for fairness of plating

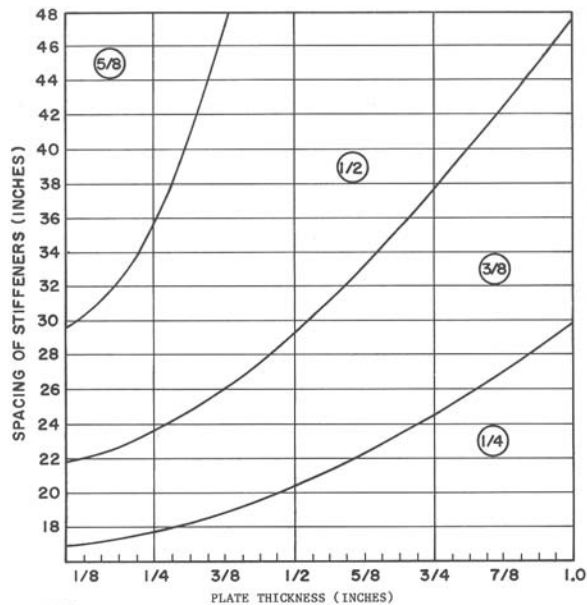

Critical areas

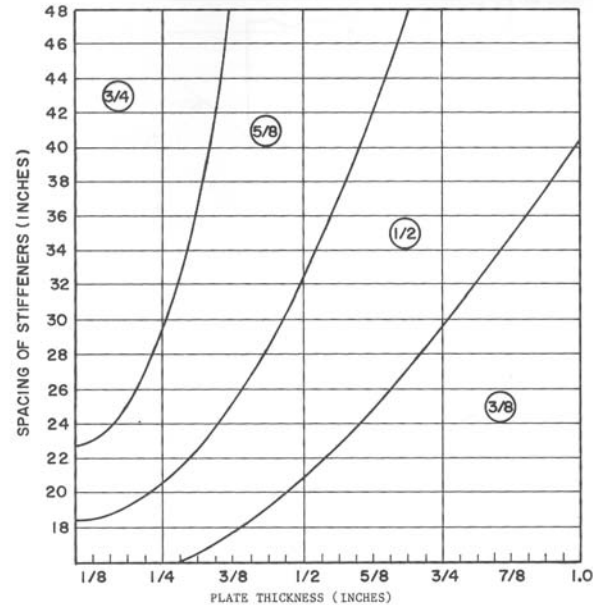

Secondary Structure — Add 1/8" for bulkheads and decks not listed

Summary of Residual Stress and Distortion

- Welded aluminum structure generally less residual stress than comparable steel structure
 - Reduced buckling strength of aluminum
 - Greater distortion for same level of residual stress
 - Especially in plating
- Much less research on the residual stresses and distortion of for aluminum ship structure compared to research for steel structure
 - Work is needed.

Chapter 9

Fatigue and Fracture Design and Analysis Procedures

- S-N curves
- Experimental data extremely variable
 - As much as a full order of magnitude
 - Large number of test specimens required
- Significant time required
 - Fatigue life of 10^7 cycles requires 115 days at 1 cycle per second
- Not all fatigue design codes acknowledge a fatigue endurance limit
 - Most are bilinear at point such as 5×10^6
 - Lesser slope for the higher number of cycles
 - Not universal agreement that reduction in slope is valid
 - Aluminum operating in seawater
 - Effect of assumption on predicted fatigue life significant
 - If bilinear S-N curve replaced with linear S-N curve, Predicted life decreases by decrease by 30 percent.

$$N = AS^{\frac{1}{m}}$$

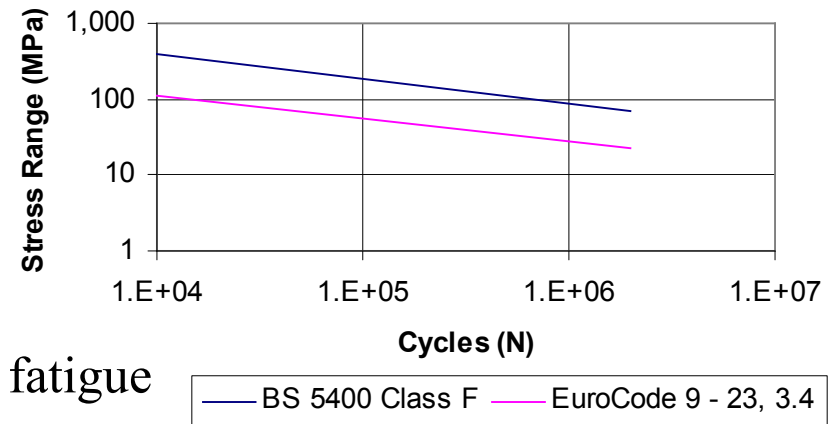

Comparison of Aluminum and Steel



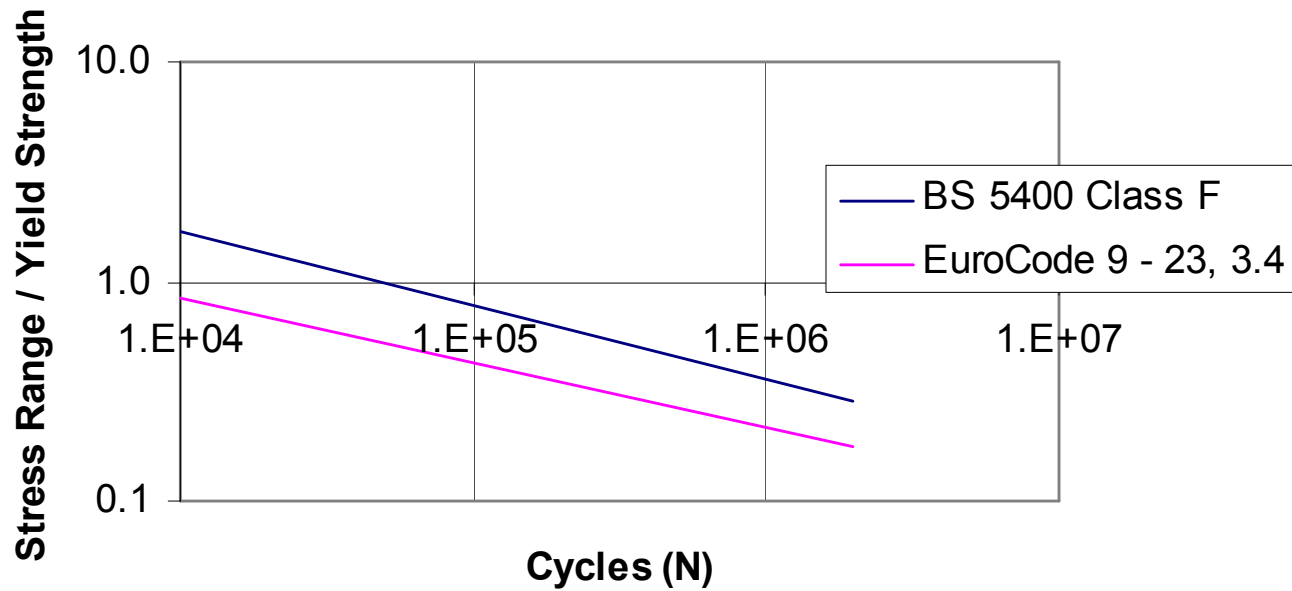

- Aluminum alloy 5086-H116 welded yield strength = 131 MPa
- Ordinary Strength Steel yield strength = 235 MPa
 - o 1.8 times higher than 5086-H116 aluminum





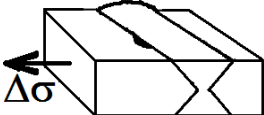

Fatigue Design Curves

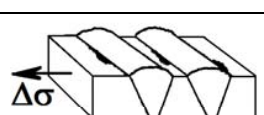
- Eurocode 9
 - o Based on large-scale testing of details at lower-stress, higher-cycle lives
- Fatigue classifications of Eurocode 9
 - o Based on stress range of the S-N curve at 2×10^6 cycles
 - o Negative slope of the S-N curve at that point
 - o Full penetration transverse butt weld 35, 3.4
 - o Design S-N curves two standard deviations below mean of experimental data
 - Probability of 2.3 percent of failure
 - After N or less loading cycles at the given stress level
- Other Aluminum Fatigue Curves
 - o The Aluminum Association

Fatigue Classification of Aluminum Structural Details under Eurocode 9, Butt Welds

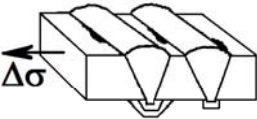
Detail Type	Internal Quality ¹	Geometric Quality ²	Type ³	Eurocode 9 Class ⁴	Sketch
Base Metal				70, 7.00	
Butt Weld, ground flush	B	B	FL	55, 7.00	
Butt Weld, ground flush	C	C	OP	45, 7.00	
Butt Weld, double sided	B	C	FL	50, 4.3	
Butt Weld, double sided	B	B	OP	40, 3.4	
Butt Weld, double sided	C	C	OP	35, 3.4	
Butt Weld, single sided with backing	C	C	FL	40, 4.3	

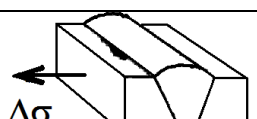
Fatigue Classification of Aluminum Structural Details under Eurocode 9, Butt Welds (Cont.)

Detail Type	Internal Quality ¹	Geometric Quality ²	Type ³	Eurocode 9 Class ⁴	Sketch
Butt Weld, single sided with backing	C	C	OP. HA	30, 3.4	
Butt Weld, single sided, no backing	B	B	FL	45, 4.3	
Butt Weld, single sided, no backing	C	C	FL	40, 4.3	
Butt Weld, single sided, no backing	C	C	OP. HA	30,3.4	
Butt Weld, single sided, partial penetration	D	C		18, 3.4	

1. EN 30 042

2. EN 30 042

3. FL, flats, solids; OP, open shapes; HO, hollow, tubular

4. Stress range at 2×10^6 cycles, negative slope

Fatigue Classification of Aluminum Structural Details under Eurocode 9, Cruciform Joints

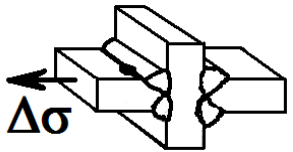
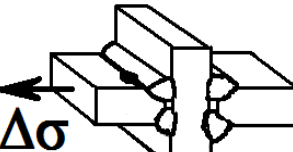
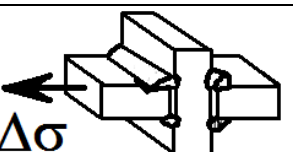
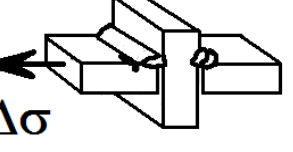
Detail Type	Internal Quality ¹	Geometric Quality ²	Eurocode 9 Class ³	Sketch
Cruciform, full penetration	B	B	35, 3.4	
Cruciform, partial penetration	C	C	30, 3.4	
Cruciform, no penetration	C	C	25, 3.4	
Cruciform, one sided	C	C	12, 3.4	



1. EN 30 042

2. EN 30 042

3. FL, flats, solids; OP, open shapes; HO, hollow, tubular

4. Stress range at 2×10^6 cycles, negative slope

Fatigue Classification of Aluminum Structural Details under Eurocode 9, Lap Joints

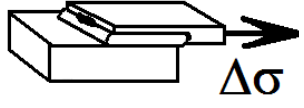
Detail Type	Internal Quality ¹	Geometric Quality ²	Eurocode 9 Class ³	Sketch
Lap Joint, Crack at Base of Weld	C	C	23, 3.4	
Lap Joint, Crack at Edge of Weld	C	C	18, 3.4	
Lap Joint, Crack at Fillet Toe	C	C	14, 3.4	

1. EN 30 042

2. EN 30 042

3. Stress range at 2×10^6 cycles, negative slope

Fatigue Classification of Aluminum Structural Details under Eurocode 9, Welded Attachments, Transverse Weld Toe

Detail Type	T ¹ (mm)	L ² (mm)	Eurocode 9 Class ³	Sketch
Attachment on Surface	≤ 15	≤ 20	31, 3.4	
Attachment on Surface	≤ 4	> 20	25, 3.4	
Attachment on Surface	4 < T ≤ 10	> 20	22, 3.4	
Attachment on Surface	10 < T ≤ 15	> 20	20, 3.4	
Attachment overlapping edge	≤ 15	≤ 20	27.3, 3.4	

Fatigue Classification of Aluminum Structural Details under Eurocode 9, Welded Attachments, Transverse Weld Toe (Cont.)

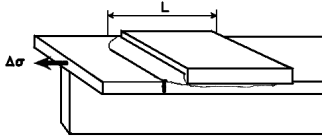
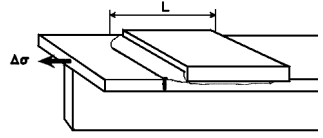
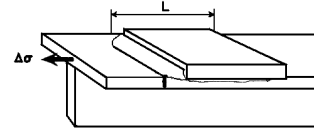
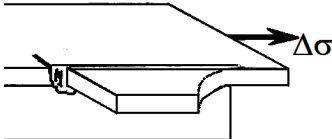
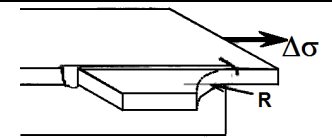
Detail Type	T ¹ (mm)	L ² (mm)	Eurocode 9 Class ³	Sketch
Attachment overlapping edge	≤ 4	> 20	22.0, 3.4	
Attachment overlapping edge	4 < T ≤ 10	> 20	19.4, 3.4	
Attachment overlapping edge	10 < T ≤ 15	> 20	17.6, 3.4	
Attachment on Edge			18, 3.4	
Attachment on Edge, Radius ≥ 50 mm, ground smooth			35, 3.4	

Fatigue Classification of Aluminum Structural Details under Eurocode 9, Welded Attachments, Transverse Weld Toe (Cont.)

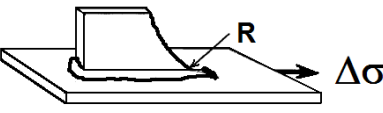
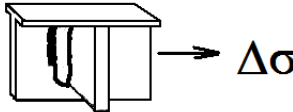
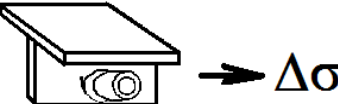
Detail Type	T ¹ (mm)	L ² (mm)	Eurocode 9 Class ³	Sketch
Attachment parallel to stress			23, 3.4	
Attachment parallel to stress, Radius ≥ 50 mm, ground smooth			35, 3.4	
Web Chock			23, 3.4	
Attachment tube			23, 3.4	

1. Thickness of base plate, mm
2. Length of attachment, mm
3. Stress range at 2×10^6 cycles, negative slope

Fatigue Classification of Aluminum Structural Details under Eurocode 9, Welded Attachments, Longitudinal Welds

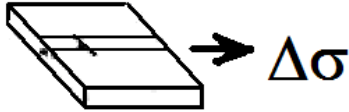
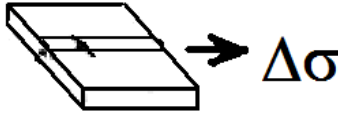
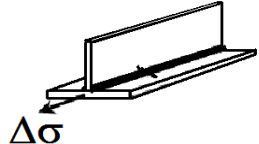
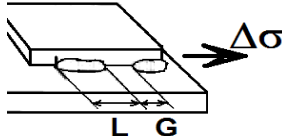
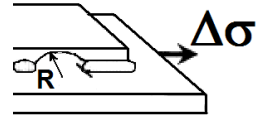
Detail Type	Internal Weld Quality ¹	Geometric Weld Quality ²	Eurocode 9 Class ³	Sketch
Full Penetration Butt Weld, Ground Flush	B	C	60, 4.3	
Full Penetration Butt Weld, Ground Flush	C	C	55, 4.3	
Full Penetration Butt Weld	C	D	45, 4.3	
Continuous Fillet Weld with or without stop/starts	C	D	40, 4.3	
Intermittent Fillet Weld, $G \leq 2.5 L$	C	D	35, 4.3	
Rat Hole, $R \leq 2.5 \text{ mm}$	C	D	28, 3.4	

1. Weld Quality in accordance with EN 30 D42.
2. Weld Quality in accordance with EN 30 D42.
3. Stress range at 2×10^6 cycles, negative slope

Fatigue Classification of Aluminum Structural Details under Eurocode 9, Welded Attachments to Built-up Beam

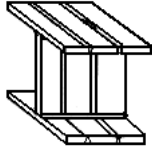
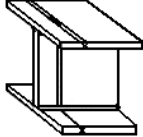
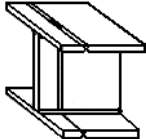
Detail Type	Internal Quality ¹	Geometric Quality ²	Eurocode 9 Class ³	Sketch
Butt Weld, full penetration, ground flush, single or double sided	B	B	40, 3.4	
Butt Weld, full penetration, double sided	B	C	35, 3.4	
Butt Weld, full penetration, single sided	C	C	30, 3.4	

Fatigue Classification of Aluminum Structural Details under Eurocode 9, Welded Attachments to Built-up Beam (Cont.)

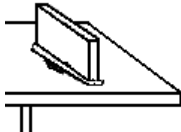
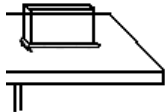
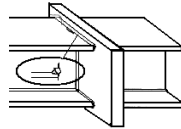
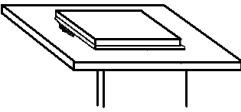
Detail Type	Internal Quality ¹	Geometric Quality ²	Eurocode 9 Class ³	Sketch
Transverse chock	C	C	18, 3.4	
Longitudinal chock	C	C	23, 3.4	
Cruciform, double sided	C	C	25, 4.3	
Attachment on Surface	C	C	20, 4.3	

1. Weld Quality in accordance with EN 30 D42.
2. Weld Quality in accordance with EN 30 D42.
3. Stress range at 2×10^6 cycles, negative slope

Fatigue Classification of Aluminum Structural Details not Covered under Eurocode 9

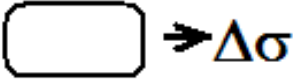
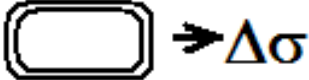
Detail Type	Internal Quality ¹	Geometric Quality ²	Eurocode 9 Class ³	Sketch
Unreinforced Opening ⁴			45, 4.84	
Reinforced Opening ⁴			40, 3.4	

1. Weld Quality in accordance with EN 30 D42.
2. Weld Quality in accordance with EN 30 D42.
3. Stress range at 2×10^6 cycles, negative slope
4. Requires stress concentration computation.

Fatigue Data for Specific Ship Details

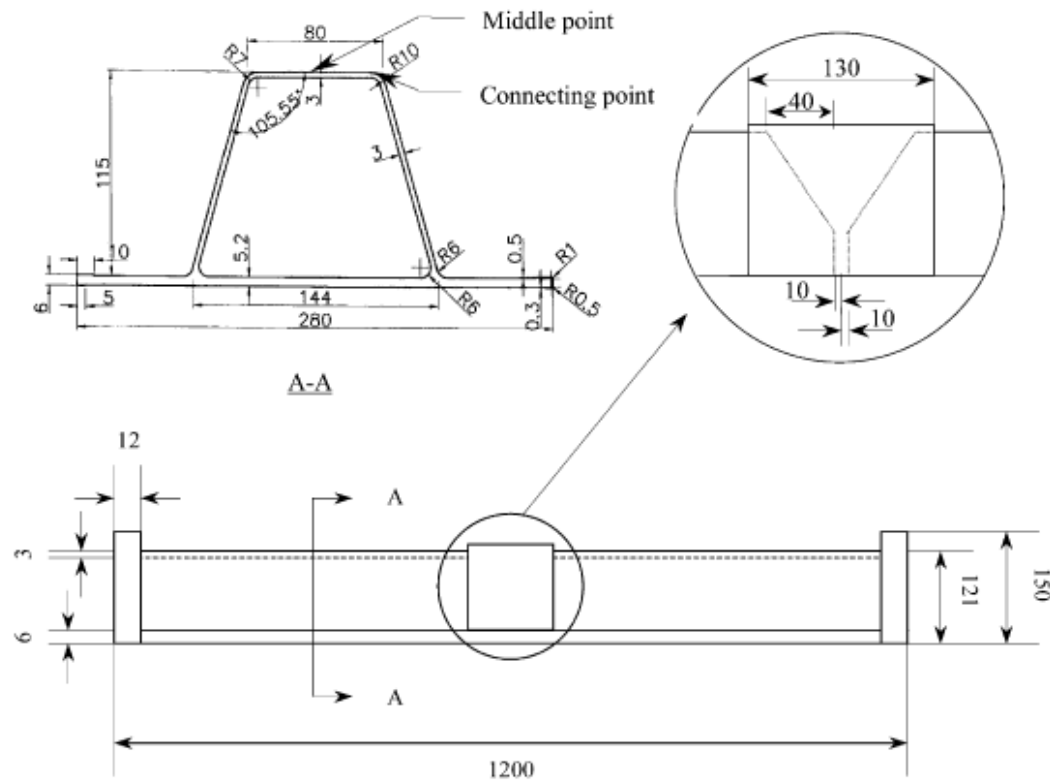

Box stiffener lap joints (Ye and Moan, 2002)

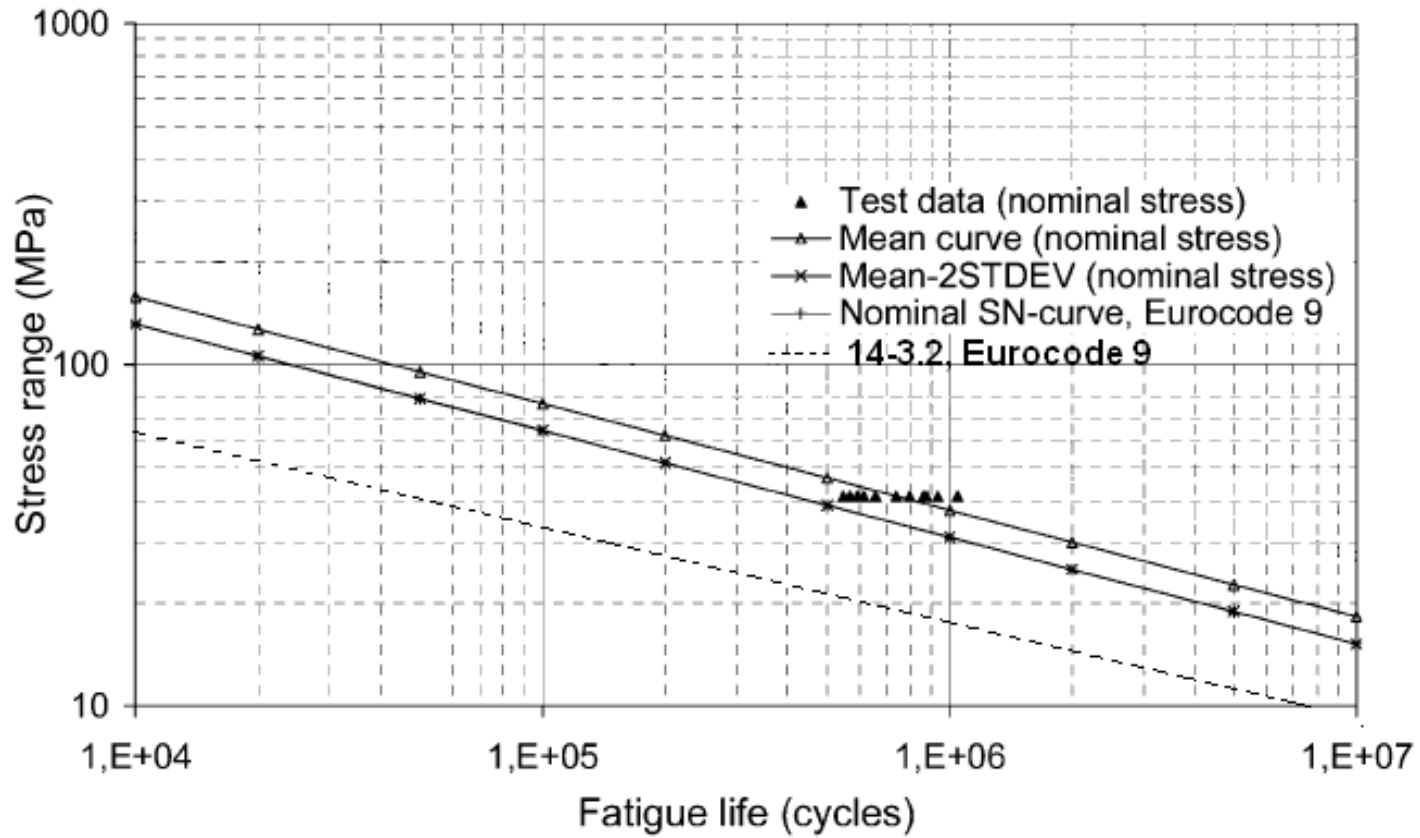

Fatigue of lapped joints of box girders (Ye and Moan, 2002)

Fatigue Data for Specific Ship Details

Intersection of a vertical bulkhead stiffener
with a bottom longitudinal stiffener (Beach et al. 1981)

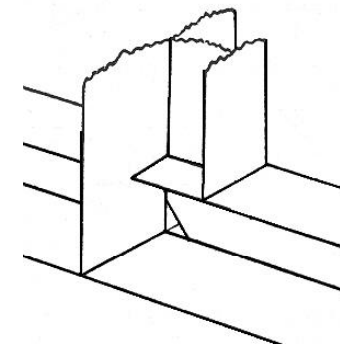
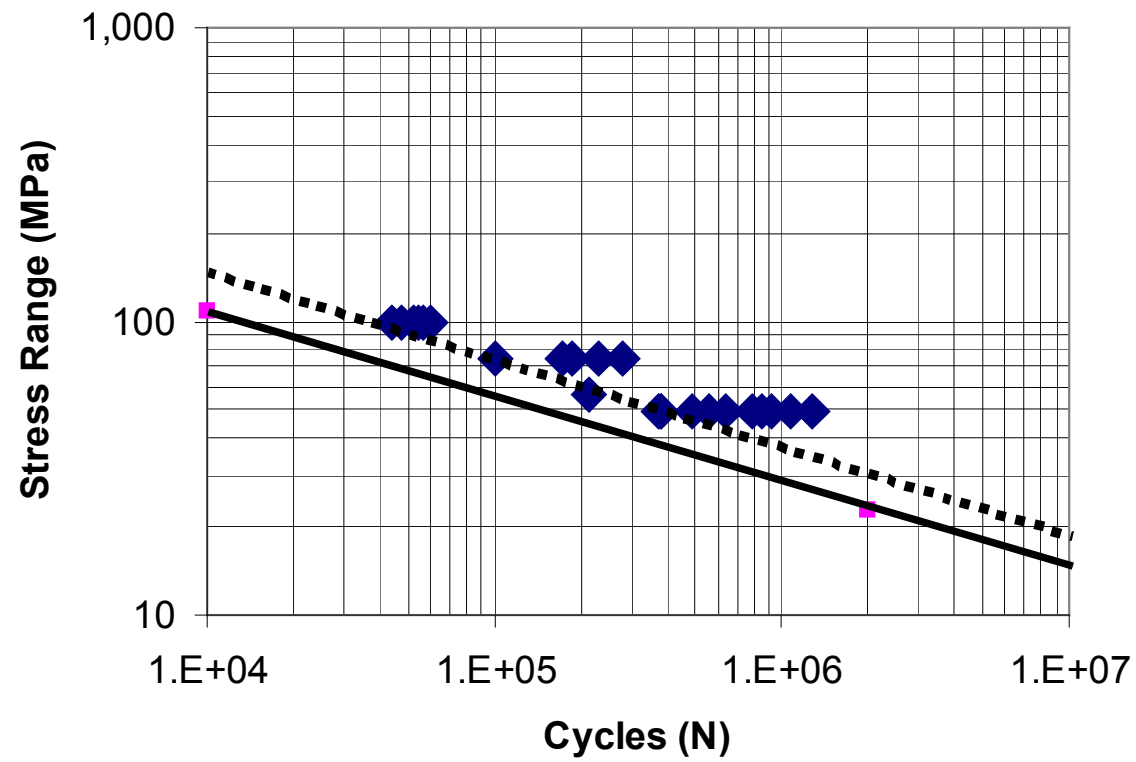

Fatigue Analysis for Operation in a Seaway

- Vessels operating in a seaway have random loading
 - Lifetime of 20 years = more than 10 million loading cycles
 - High-speed ships even more, as many as 10^9 cycles
- Fatigue-loading spectrum
 - Summation of all the loading cycles that a ship experiences over its lifetime

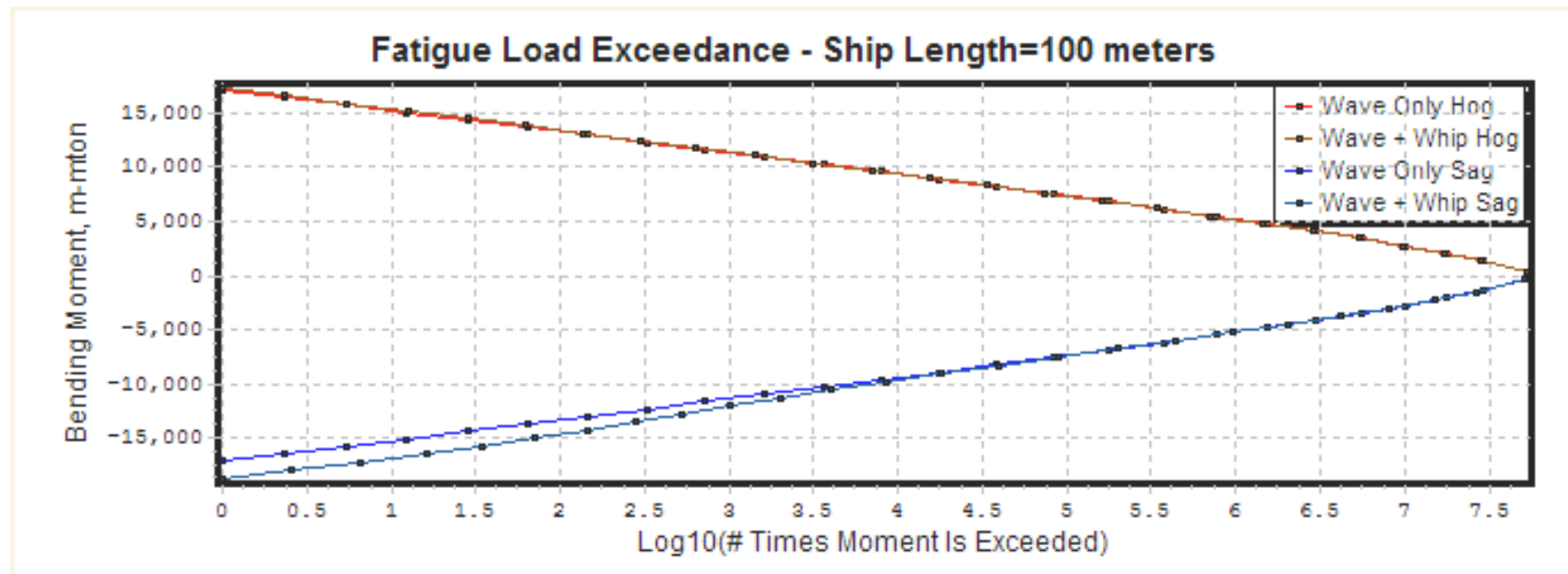

Typical fatigue loading spectrum for a 100-meter ship (SPECTRA 8.2)

Linear Cumulative Fatigue Damage

Palmgren-Miner Rule

$$D = \sum_{i=1}^n \frac{n_i}{N_i} \leq 1.0$$

- Assumes fatigue damage is independent of the loading sequence
- Example
 - o Loading spectrum over 20-year life developed
 - Spectrum stated in units of stress
 - Same units as in S-N curve
- Linear calculations
- Obtain bending moments spectrum
- Convert to stress
 - o Divide by section modulus
 - o Multiply by stress coefficient
 - Stress at point at hull
 - Caused by unit bending moment amidships
 - Use for finite element analysis
- In example, summation = 0.9477
 - o Less than 1.0
 - o 20-year fatigue life goal met

Example of Cumulative Linear Fatigue Calculation

S/S_{\max}	Stress Range (n) (MPa)	Cycles Exceeded	# Cycles at Stress	Block Stress (MPa)	Lower Fatigue Cycles (N_1)	Upper Fatigue Cycles (N_2)	Fatigue Cycles (N)	Fatigue Damage
1.00	67.70	1.00E+00	1.25E+00	66.35	5.4542E+04	3.8237E+03	5.4542E+04	0.000023
0.96	64.99	2.25E+00	2.78E+00	63.64	6.2845E+04	4.7886E+03	6.2845E+04	0.000044
0.92	62.28	5.03E+00	6.17E+00	60.93	7.2858E+04	6.0561E+03	7.2858E+04	0.000085
0.88	59.58	1.12E+01	1.36E+01	58.22	8.5037E+04	7.7412E+03	8.5037E+04	0.000160
0.84	56.87	2.48E+01	2.99E+01	55.51	9.9985E+04	1.0012E+04	9.9985E+04	0.000299
0.80	54.16	5.47E+01	6.54E+01	52.81	1.1852E+05	1.3116E+04	1.1852E+05	0.000552
0.76	51.45	1.20E+02	1.42E+02	50.10	1.4175E+05	1.7428E+04	1.4175E+05	0.001002
0.72	48.74	2.62E+02	3.07E+02	47.39	1.7123E+05	2.3527E+04	1.7123E+05	0.001792
0.68	46.04	5.69E+02	6.59E+02	44.68	2.0915E+05	3.2327E+04	2.0915E+05	0.003150
0.64	43.33	1.23E+03	1.40E+03	41.97	2.5869E+05	4.5309E+04	2.5869E+05	0.005431
0.60	40.62	2.63E+03	2.98E+03	39.27	3.2452E+05	6.4951E+04	3.2452E+05	0.009169
0.56	37.91	5.61E+03	6.26E+03	36.56	4.1378E+05	9.5537E+04	4.1378E+05	0.015117
0.52	35.20	1.19E+04	1.30E+04	33.85	5.3753E+05	1.4476E+05	5.3753E+05	0.024269
0.48	32.50	2.49E+04	2.70E+04	31.14	7.1372E+05	2.2709E+05	7.1372E+05	0.037793
0.44	29.79	5.19E+04	5.53E+04	28.43	9.7242E+05	3.7115E+05	9.7242E+05	0.056822
0.40	27.08	1.07E+05	1.12E+05	25.73	1.3666E+06	6.3719E+05	1.3666E+06	0.081982
0.36	24.37	2.19E+05	2.25E+05	23.02	1.9947E+06	1.1618E+06	1.9947E+06	0.112602
0.32	21.66	4.44E+05	4.45E+05	20.31	3.0527E+06	2.2837E+06	3.0527E+06	0.145638
0.28	18.96	8.88E+05	8.67E+05	17.60	4.9659E+06	4.9459E+06	4.9659E+06	0.174667
0.24	16.25	1.76E+06	1.66E+06	14.89	8.7633E+06	1.2190E+07	1.2190E+07	0.136478
0.20	13.54	3.42E+06	3.13E+06	12.19	1.7337E+07	3.6027E+07	3.6027E+07	0.086784
0.16	10.83	6.55E+06	5.73E+06	9.48	4.0744E+07	1.3996E+08	1.3996E+08	0.040906
0.12	8.12	1.23E+07	1.01E+07	6.77	1.2791E+08	8.6119E+08	8.6119E+08	0.011748
0.08	5.42	2.24E+07	1.69E+07	4.06	7.2642E+08	1.3586E+10	1.3586E+10	0.001242
0.04	2.71	3.93E+07	2.37E+07	1.35	3.0437E+10	5.1232E+12	5.1232E+12	0.000005
0.00	0.00	6.30E+07	Cumulative Total Damage =					0.947761

Development of Fatigue Loading Spectra

Weibull distribution

$$N = N_{\max} \times \exp\left(-\left(\frac{S}{S_{\max}}\right)^{\zeta} \times \ln(N_{\max})\right)$$

N is the number of loading cycles at stress range S ,

N_{\max} is total number of loading cycles,

S_{\max} is the maximum load range,

ζ is a Weibull parameter.

$\zeta = 1.0$, the distribution is an exponential distribution

$\zeta = 2.0$, the distribution is a Rayleigh distribution

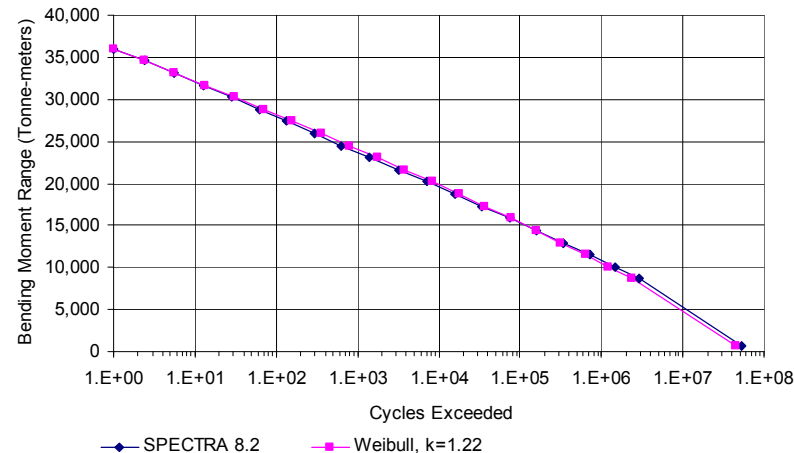

Weibull distribution fit to distribution from SPECTRA 8.2

Weibull Distribution (Cont.)

- SPECTRA run for a series of vessels
 - Weibull distribution fit to fatigue loading spectrum
- For preliminary design, assume maximum stress range from strength calculation
 - Develop fatigue loading spectrum using coefficients based on length of ship

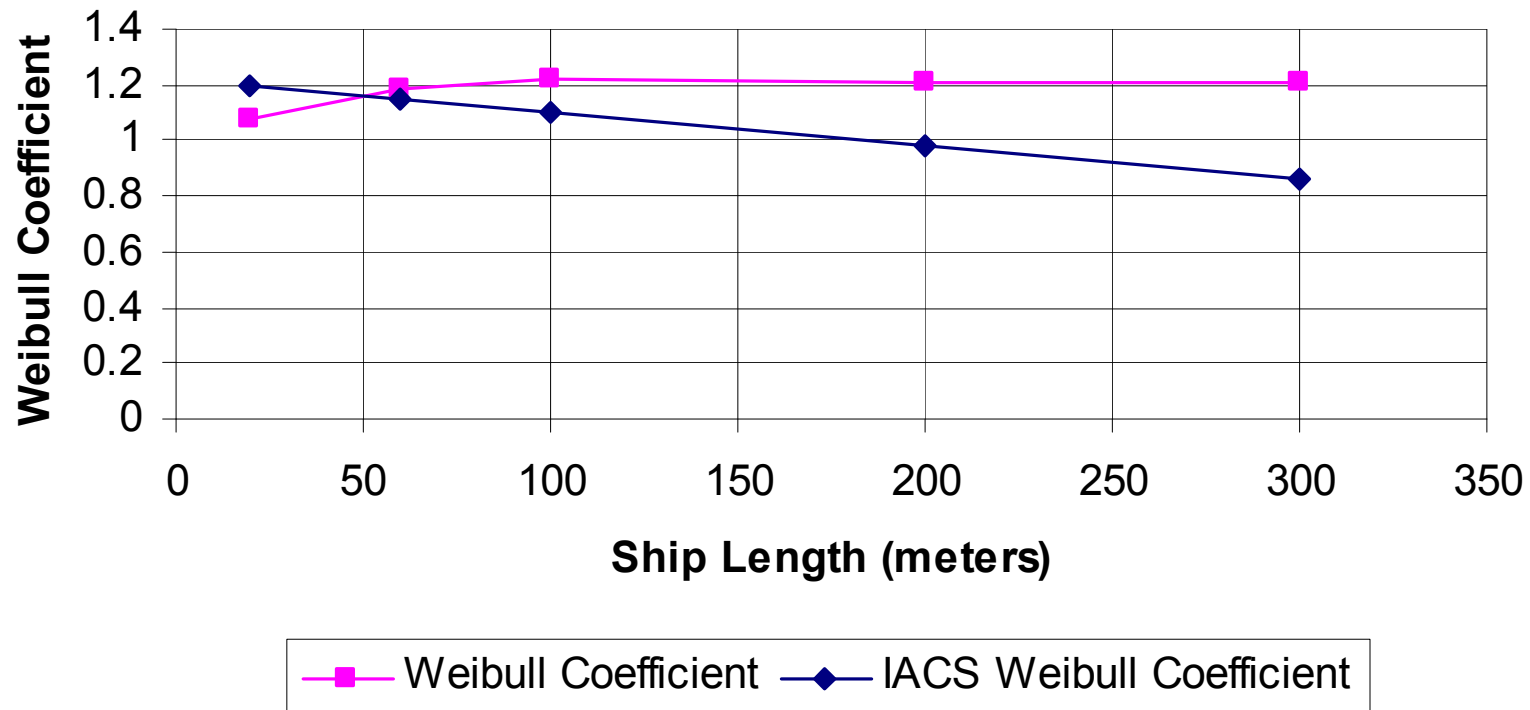

Weibull Distribution (Cont.)

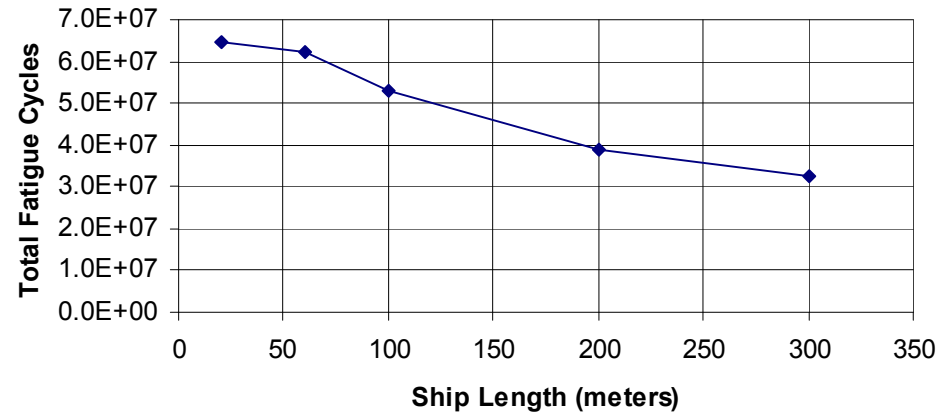

Total fatigue loading cycles for operation 80 percent over 20 years versus ship length

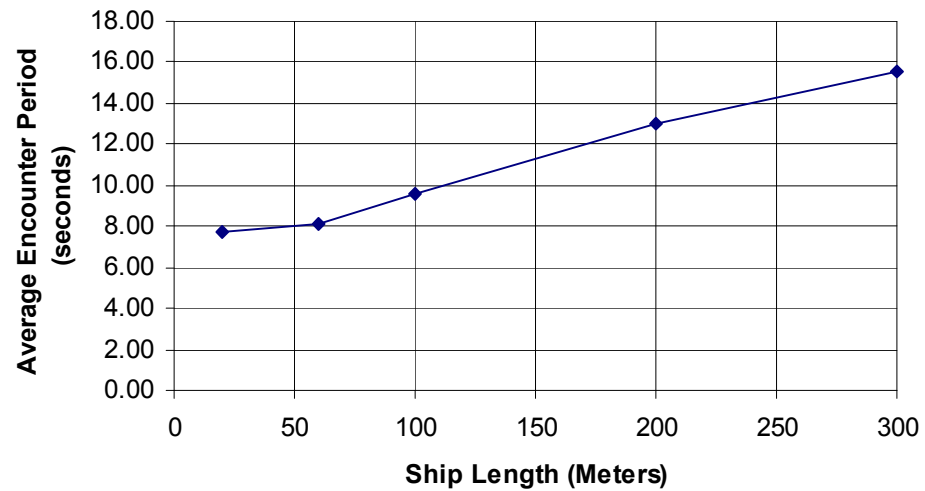

Average encounter period versus ship length

Spectral Fatigue Analysis

- ABS Guidance Notes on Spectral-Based Fatigue Analysis for Vessels (ABS, 2004)
 - o S-N curves for steel structure used
 - o Procedure will work Eurocode 9 or any other source of S-N data for aluminum
- ABS procedure rather involved
 - o Requires calculation of complex stress transfer functions for all structural details being analyzed
 - o Determined by finite element analysis
- Hull loading is determined by a seakeeping program
 - o Provides pressure loads on the hull plating for a range of wave headings and frequencies
 - o Thousands of such calculations must be performed
 - o Automated method of tracking stress response is needed.
- ABS procedure must be augmented for high-speed craft
 - o Account for the anticipated operational profile
 - o 60-knot craft in general will not operate at full speed in all sea states
 - o Preferred headings relative to wave direction may be taken
 - o Specific wave energy spectra for the areas in which the craft will be operating should be used instead of a general ocean profile

Fatigue Crack Growth

Rate of fatigue crack growth is related to the linear elastic stress intensity factor, K ,

$$K = Y \sigma \sqrt{\pi a}$$

a is the length of the crack

Sometimes $a / 2$ used

σ is the field stress in the vicinity of the crack, and

Y is a factor depending on the geometry of the structure in which the crack exists.

Stress Intensity Factors for a Few Geometries

Configuration	K	Comments
Crack normal to direction of stress in an infinite plate	$\sigma \sqrt{\pi a}$	a is one-half the crack length
Crack normal to direction of stress at the edge of a plate infinite in the direction of crack propagation.	$1.1 \sigma \sqrt{\pi a}$	a is the crack length
Crack normal to direction of stress in the center of a plate of width W	$\sigma \sqrt{\pi a} \sqrt{\secant\left(\frac{\pi a}{W}\right)}$	a is one-half the crack length

Fatigue Crack Growth (Cont.)

- Alternating stress intensity factor range, ΔK
 - Used to determine rate of crack growth, da/dN
 - For each cycle, N , of stress range $\Delta\sigma$

Fatigue crack growth da/dN curve
 5083 aluminum
 (Donald and Blair, 2007)

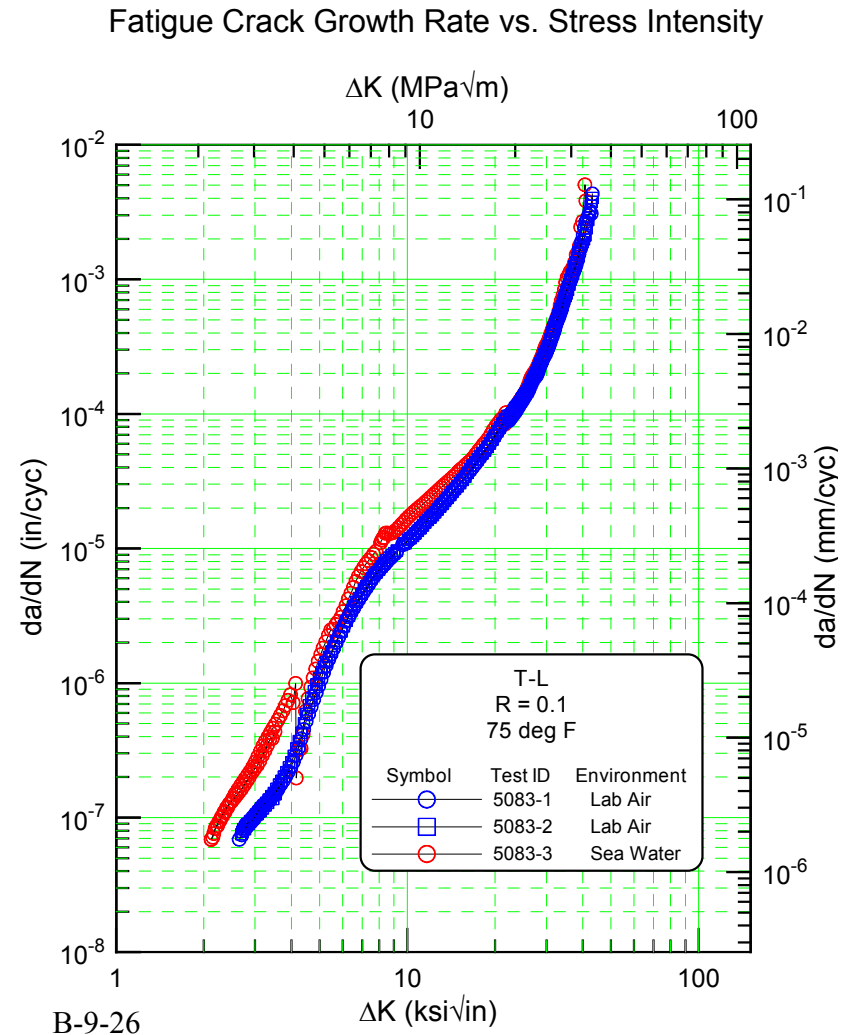

Fatigue Crack Growth (Cont.)

- S-shaped curve on the log-log fatigue crack growth curve
- Three regions
 - o Region I for low values of ΔK
 - Rates of crack growth da/dN decreasing as ΔK decreases
 - ΔK reaches some threshold value below which no crack growth will occur
 - o Upper region III for higher values of ΔK
 - Crack growth rate increases rapidly
 - Point of unstable crack growth for high values of ΔK
 - o Intermediate region II approximated linear relationship on the log-log plot:
 - Paris equation

$$\bullet \frac{da}{dN} = A(\Delta K)^m$$

- Two methods of addressing data used
 - o Adopt a single standard region II straight-line upper limit to the data
 - Done for steel but not for aluminum
 - o Piecewise approximation to data
 - Use Paris equation as an interpolation function

Fatigue Crack Growth Computation

- Load sequence effects are very important
 - Fatigue-loading histogram must be broken into loading blocks
 - In example, 240 blocks are used
 - Each block represents one month of operation
- Initial crack size of 24 millimeters chosen (half-crack length of 12 mm)
 - Size fairly detectable with careful inspection
- Assumed to be in the center of the deck
 - Considered to be an infinite plate
 - $\Delta K = \sigma \sqrt{\pi a}$
 - Calculations are continued for 24 blocks
 - Representing 24 months of operation
- Calculations also made for equivalent steel vessel
 - Section modulus of aluminum vessel increased over rule minimum
 - Result of fatigue analysis

Fatigue Crack Growth Calculation for a 42.7-meter Aluminum Vessel

Sub-block	Cycles (N)	Stress Range (MPa)	Half-Crack Size (a) (mm)	ΔK (MPa m ^{1/2})	m	A	da/dN (mm/cycle)	Crack growth (da) (mm)
1	5.20E-03	66.35	1.20E+01	12.88	2.73	7.44E-07	7.99E-04	4.15E-06
2	1.16E-02	63.64	1.20E+01	12.36	2.73	7.44E-07	7.13E-04	8.26E-06
3	2.57E-02	60.93	1.20E+01	11.83	2.73	7.44E-07	6.33E-04	1.63E-05
4	5.67E-02	58.22	1.20E+01	11.30	2.73	7.44E-07	5.59E-04	3.17E-05
5	1.25E-01	55.51	1.20E+01	10.78	2.73	7.44E-07	4.91E-04	6.12E-05
6	2.72E-01	52.81	1.20E+01	10.25	2.73	7.44E-07	4.28E-04	1.17E-04
7	5.92E-01	50.10	1.20E+01	9.73	2.63	9.21E-07	3.68E-04	2.18E-04
8	1.28E+00	47.39	1.20E+01	9.20	2.63	9.21E-07	3.18E-04	4.07E-04
9	2.74E+00	44.68	1.20E+01	8.68	2.38	1.54E-06	2.67E-04	7.33E-04
10	5.85E+00	41.97	1.20E+01	8.15	2.38	1.54E-06	2.30E-04	1.35E-03
11	1.24E+01	39.27	1.20E+01	7.62	3.73	1.12E-07	2.20E-04	2.73E-03
12	2.61E+01	36.56	1.20E+01	7.10	3.73	1.12E-07	1.69E-04	4.40E-03
13	5.44E+01	33.85	1.20E+01	6.58	6.03	1.84E-09	1.56E-04	8.49E-03
14	1.12E+02	31.14	1.20E+01	6.05	6.03	1.84E-09	9.47E-05	1.06E-02
15	2.30E+02	28.43	1.20E+01	5.53	5.92	2.17E-09	5.43E-05	1.25E-02
16	4.67E+02	25.73	1.20E+01	5.00	5.92	2.17E-09	3.01E-05	1.41E-02
17	9.36E+02	23.02	1.21E+01	4.48	4.82	1.00E-08	1.38E-05	1.29E-02
18	1.85E+03	20.31	1.21E+01	3.95	3.42	4.67E-08	5.14E-06	9.53E-03
19	3.61E+03	17.60	1.21E+01	3.43	3.42	4.67E-08	3.16E-06	1.14E-02
20	6.93E+03	14.89	1.21E+01	2.90	12.29	1.00E-10	4.86E-05	3.37E-01
21	1.30E+04	12.19	1.24E+01	2.41	12.29	1.00E-10	4.89E-06	6.37E-02
22	2.39E+04	9.48	1.25E+01	1.88	0.00	1.00E-10	1.00E-10	2.39E-06
23	4.22E+04	6.77	1.25E+01	1.34	0.00	1.00E-10	1.00E-10	4.22E-06
24	7.03E+04	4.06	1.25E+01	0.80	0.00	1.00E-10	1.00E-10	7.03E-06

Fatigue Crack Growth Calculation for a 42.7-meter Aluminum Vessel (Cont.)

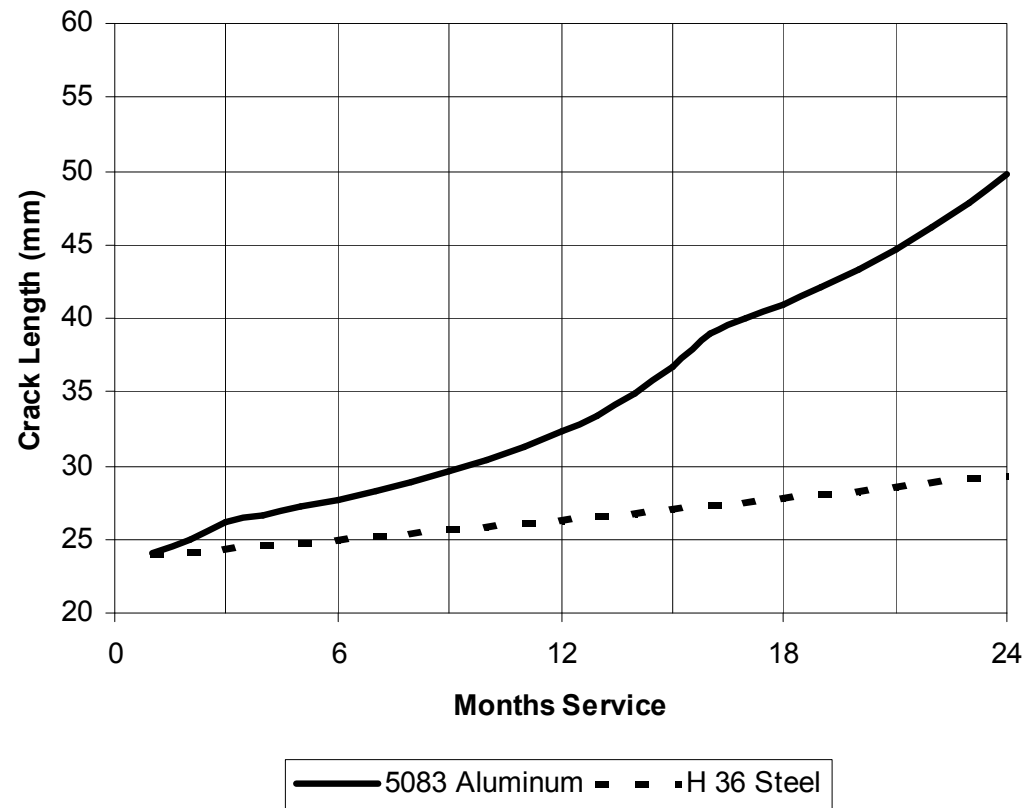

Predicted crack growth for a 4.39-m 32-knot craft.

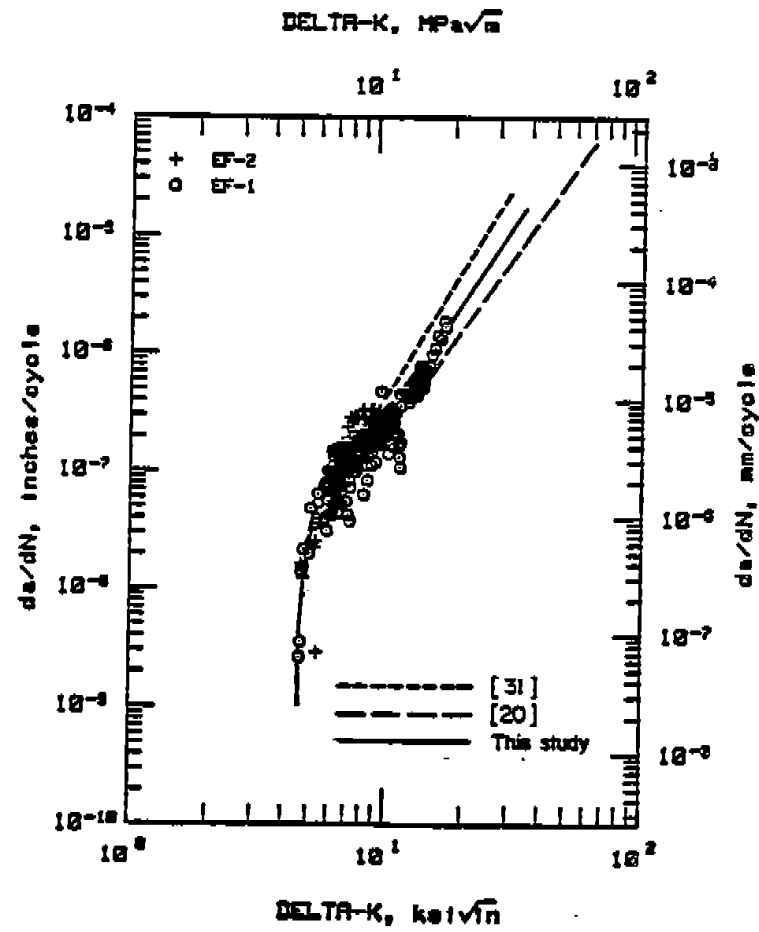

Fatigue crack growth da/dN curve for ABS Grade CH 36 steel (Leis, 1990).

Fracture

- Fracture mechanics studies failure of material under stress in the presence of a crack
 - Brittle materials, such as glass
 - Linear elastic stress intensity factor K is used
 - Ductile materials, such as the aluminum and steel alloys
 - Plastic flow occurs at the crack tip
 - Linear elastic analysis highly over-conservative
 - Predicting failure where there is no danger of it occurring
- J-Integral parameter is one of several methods used
 - Can also be overly conservative for tough, ductile materials
 - For calculation at stress levels prior to crack growth
 - Applied J-Integral can be determined from the stress intensity factor

$$J = \frac{K^2}{E}$$

- J generally expressed Joules/mm², or kilo inch-pound/inch²
 - R-curve represents J-Integral for ductile material such as ship-grade aluminum and steel
 - Critical value of J
 - JIC is defined as the intersection of the R-curve with a line offset from the origin and with a value of $J = 2 \sigma_Y a$.

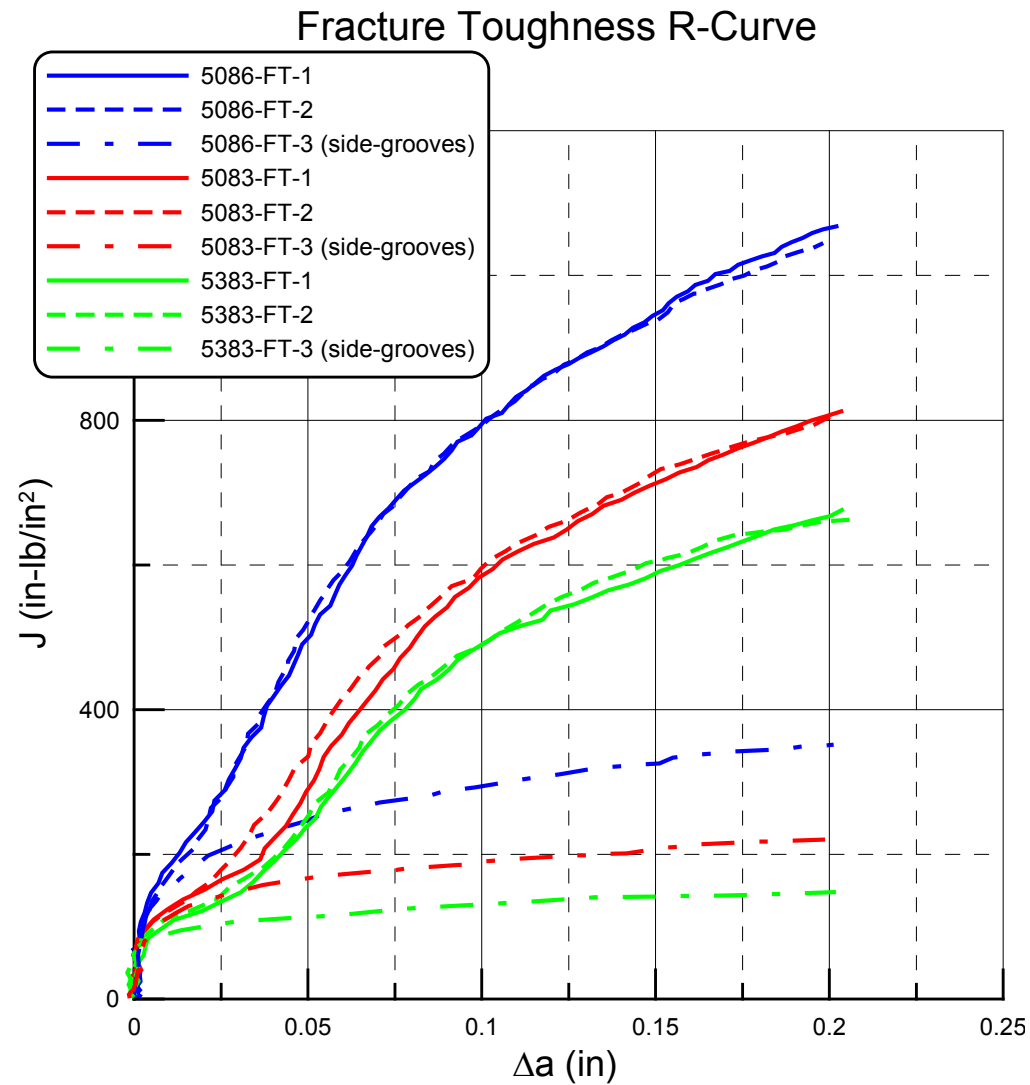

**Fracture Toughness R-curves for several aluminum alloys
(Donald and Blair, 2007)**

Fracture Calculation

- For the example made
 - Fatigue crack growth in a 42.7 m 32-kt crew boat
 - The stress to the deck in the aluminum version is 91 MPa compression and 20 MPa tension
 - Fracture analysis in the crack opening mode
 - Only the maximum tensile stress is considered

$$J_{\text{appl}} = \frac{\sigma^2 \pi a}{E} = \frac{(20)^2 \pi a}{71 \times 10^3} = 17.7 \times 10^{-3} a \frac{\text{N} \cdot \text{mm}}{\text{mm}^2}$$

- From R-curves for 5086 aluminum
 - $J_{\text{IC}} = 100 \text{ in-lb/in}^2 = 17.5 \text{ N-mm/mm}^2$
- Critical crack size = $17.5 / 17.7 \times 10^{-3} = 990 \text{ mm}$
 - Actual critical crack length is twice this, or 1.9 m
- If stress level = welded yield strength = 165 MPa, critical crack length = 30 mm
- Comparison with steel
 - R-curve for ABS Grade EH 36 steel (fairly tough grade)
 - $J_{\text{IC}} = 240 \text{ N-mm/mm}^2$
 - Maximum deck stress = 25 MPa in hogging
 - Critical crack size = 50 meters
 - If stress = yield strength = 355 MPa, the critical crack size = 250 mm

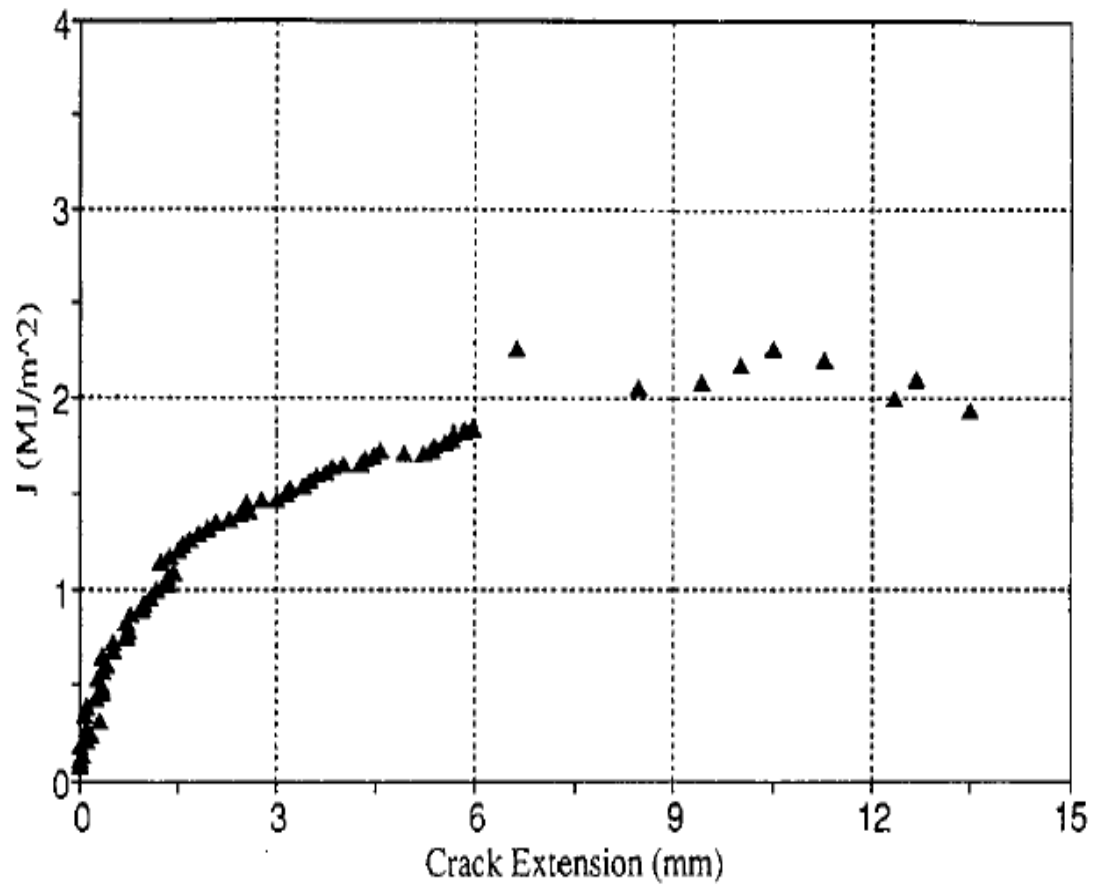

**Fracture toughness R-curve for 9.5-mm ABS Grade EH 36 steel
in the L-T orientation (Dexter and Gentilcore, 1997)**

Summary of Fatigue and Fracture

- During preliminary design
 - Use generalized procedure for determining a fatigue-loading spectrum
 - Assure potential fatigue problems addresses early in design process
- Final stages of design
 - Detailed spectral fatigue analysis
- Aluminum design must be based on avoidance of crack initiation
 - A crack can propagate up to 30 times faster in aluminum than in steel
- Aluminum structure rather tolerant of defects
 - Will not fail by fast fracture
 - Hasn't the same fracture resistance of ship-grade steels

Chapter 10

Fire Protection

- Fire protection required on ships
 - Prevent the spread of fire
 - Prevent loss of life
 - Safeguard safety of the vessel
- Amount of protection depends on size of vessel and service
- Although aluminum does not burn when exposed to ordinary fires
 - It does melt.

Result of fire aboard cruise ship
Star Princess, March 2006 (MAIB, 2006)



Regulatory Requirements

- International Convention for the Safety of Life at Sea (SOLAS, 2004)
- International Maritime Organization International (IMO)
 - o Code of Safety for High Speed Craft (HSC Code)
- U.S.-flag vessels are established by Section 46 of the U.S. Code of Federal Regulations
 - o Expanded upon in several U.S. Coast Guard Navigation and Vessel Inspection Circulars (NVIC)
- SOLAS Requirements
 - o Existed by international treaty in various forms since the 1910s
 - o Established following the *Titanic* disaster
 - o Most recent treaty was adopted on November 1, 1974
 - Convention convened by International Maritime Organization (IMO)
 - Body of the United Nations
 - o Requirements came into force May 25, 1980
 - SOLAS 1974 amended twice since then by means of protocols
 - Latest protocol February 2, 2000
 - Resolutions adopted by the Marine Safety Committee of IMO
 - Conferences of SOLAS Contracting Governments
 - o All requirements combined into single edition in 2004

SOLAS Requirements (Cont.)

- Fire safety objectives
 - Containing, controlling, and suppressing a fire or explosion to the compartment of origin
 - Provide adequate and readily accessible means of escape for passengers and crew
- Ship is divided into main horizontal and vertical thermal and structural boundaries
 - Accommodation spaces are separated from the remainder of the ship by such boundaries
 - Means of escape and access for fire fighting are provided

SOLAS Requirements (Cont.)

- Three general classes of division
 - o Class A divisions constructed of steel or other equivalent material
 - Suitably stiffened
 - Capable of preventing the passage of smoke and flame for one hour
 - Insulated to prevent the average temperature on the unexposed side from rising
 - More than 140 °C (252 °F) above the original temperature
 - Temperature at any one point shall not be more than 180 °C (324 °F) above the original temperature
 - o Four Class A divisions, A-60, A-30, A-15, and A-0
 - Temperature rise for 60, 30, 15, and 0 minutes, respectively.
 - Equivalent to steel means any non-combustible material
 - By itself or when properly insulated has structural integrity
 - Capable of maintaining integrity until end exposure period
 - Aluminum with appropriate insulation is specifically permitted by SOLAS.

SOLAS Requirements (Cont.)

- Class B divisions
 - Formed by bulkheads, decks, ceilings [SIC] (overhead coverings), and linings
 - Must be constructed of non-combustible materials
 - Capable of preventing the passage of smoke and flame for one half-hour
 - Insulated to prevent the average temperature on the unexposed side from
 - Rising more than 140 °C (2252 °F)
 - Temperature rise at any one point no more than 225 °C (405 °F)
 - Two Class B divisions, B-15 and B-0
 - Insulated to prevent specified temperature rise for 15 and 0 minutes, respectively.
- Class C divisions
 - Constructed of non-combustible materials
 - Do not have to
 - Prevent passage of smoke or flame
 - Be insulated to prevent temperature rise

IMO HSC Code

- HSC Code applies to high-speed craft
 - Capable of reaching speed of $3.7 \nabla^{0.1667}$, meters per second
 - ∇ is the volume of displacement in meters cubed.
- SOLAS tables are provided for passenger vessels and cargo vessels
 - Times that bulkheads and decks must be able to provide insulation between adjacent spaces
- 6 types of spaces including areas of major fire hazard and areas of moderate fire hazard
- Areas of major fire hazard
 - Machinery spaces and flammable liquid storerooms
 - Must be separated from each other by bulkheads and decks
 - Providing 60 minutes of protection
 - Areas of major fire hazard must be separated from areas of moderate fire hazard
- Areas of moderate fire hazard
 - Auxiliary machinery spaces and crew accommodation spaces
 - Bulkheads and decks offering 60 minutes of fire protection
 - Side having moderate fire hazard
 - Need only provide protection to an aluminum bulkhead for 30 minutes.
- Aluminum structures required to be insulated
 - Core temperature does not rise more than 200 °C (360 °F)

U.S. Coast Guard Requirements

Vessel Types Under U.S. Code of Federal Regulations 46

Subchapter of U.S Code CFR 46	Vessel Type	Applicable Parts of CFR 46
C	Uninspected Vessels	24 – 26
D	Tank Vessels	30 – 40
H	Passenger Vessels	70 – 89
I	Cargo and Miscellaneous Vessels	90 – 106
I-A	Mobile Offshore Drilling Units	107 – 109
K	Small Passenger Vessels (Subchapter K)	114 – 122
Q	Equipment, Construction, Material	159 – 165
R	Nautical Schools	166 – 169
T	Small Passenger Vessels (Subchapter T)	175 – 187
U	Oceanographic Vessels	188 – 196

U.S. Coast Guard Requirements (Cont.)

- U.S. Coast Guard does not require a vessel to be designed and constructed in accordance with SOLAS or IMO HSC
 - If IMO HSC is used, it must be used in its entirety
- U.S. Coast Guard requirements for structural fire protection are contained in NVIC 9-97
 - Supplemented by the list of approved fire protection material in the Coast Guard Equipment Lists COMDTINST M16714.3 series
 - Published periodically by the U.S. Coast Guard Commandant G-MSE-4
- Philosophy is to resist or slow the spread of fire
 - While establishing escape routes and maintaining their integrity
- Basic principles of structural fire protection
 - Use materials that are resistant to ignition and flame spread
 - Minimize the products of combustion
 - Arrange structures to resist fire spread
 - Separate people from fire and the products of combustion
- Structural fire protection is designed to be passive in nature
 - Not requiring action by personnel to make protection effective
 - Minimizing possibility of human error
- Chapter 4 of NVIC 9-97 refers to SNAME T&R Bulletin 2-21 (SNAME, 1974)

U.S. Navy Requirements

- U.S. Navy fire protection insulation requirements were once far less demanding than requirements for commercial ships
 - No specific fire zone boundaries
 - Uninsulated watertight bulkheads surrounding vital spaces
 - Containment of a fire was done by damage control parties
 - Spraying water on the opposite side of a bulkhead to prevent flame spread
- Strengthened requirements today
 - Specified in Part 1, Chapter 2 of the Naval Vessel Rules (NVR) of the American Bureau of Shipping.
- The NVR requirements are based on the IMO A.754(18) fire test procedure
 - Modified to provide a hydrocarbon pool fire exposure based on the UL 1709 fire curve
 - Three classes of barriers, Class N-0, N-30 and N-60
- Fire test includes an oil fire
 - Commercial standards are based on a wood fire
 - Higher temperatures are achieved in the U.S. Navy fire test
 - Assumption of fire from unexpended fuel from guided missile

U.S. Navy Requirements (Cont.)

- Designated bulkheads and decks designed to
 - Protect against structural failure
 - Prevent the passage of fire and smoke
- Exposed to a hydrocarbon (class B) fire for a designated test period
 - Prevent excessive temperature rise on the opposite side
 - Time period of 60 minutes or 30 minutes for Class N-60 and N-30, respectively
 - Average temperature rise of unexposed side no more than 139°C (250°F)
 - Temperature at any one point not rise more than 180°C (324°F)
 - Maximum temperature increases are the same as for SOLAS Class A divisions
- Ship length > 67 m (200 feet)
- Divided into main vertical fire zones
 - No more than 40 m or (131 feet) in length
- Surface of the fire zone boundary
 - Stepped in either or both the horizontal or vertical planes
 - Combinations of transverse bulkheads, longitudinal bulkheads, and decks
 - Continuous from the innerbottom through the superstructure
- Boundaries required to meet only the N-30 requirement

U.S. Navy Requirements (Cont.)

- Class N-0 divisions
- No flaming on the unexposed face for a minimum of 30 minutes
- Uninsulated steel bulkhead or deck
 - Minimum plating thickness of 4.5 mm (0.18 inches)
 - 4 x 4 inch Tee stiffeners spaced 635 mm (24 inches)
 - Or equivalent structure without openings or penetrations
- Aluminum structures must meet the structural integrity requirements under fire by testing
- Average temperature of the structural core
- Not rise more than 200 °C (360 °F)
- Same as IMO HSC code
- Note both specifications are for temperature rise
- Not for maximum temperature to prevent softening and collapse of aluminum
 - Assumes a moderate ambient temperature
 - If the ambient temperature is high, such as in an engine room
 - Consider additional insulation
 - NVR does not specifically say so

Fire Protection Insulation

- Guidance for protection of aluminum is provided by SNAME T&R Bulletin 2-21 (SNAME 1974)
 - Structural fire protection of aluminum
 - Designed to prevent aluminum from achieving a temperature of 230 °C (446 °F)
- Specifications stated above specify a temperature rise of 200 °C
 - Implicit assumption that ambient temperature not greater than 30 °C (86 °F)
- Insulation Necessary to Protect Unexposed Surfaces
 - “S” value of the insulation
 - Insulation with a thickness of 1.0 x S
 - Capable of keeping the temperature on the side of the structure that is not exposed to fire (the unexposed side) from reaching a temperature that is more than 139 °C (282 °F) above ambient for 60 minutes
 - Different materials have different thicknesses for providing a rating of S = 1.0.
- U.S. Coast Guard Equipment Lists (COMDTINST M16714.3 series)
 - Provide approved materials
 - Lists on web site www.USCG.mil or <http://cgmix.uscg.mil/> Equipment

U.S. Coast Guard Approved Fire Protection (U.S. Coast Guard Equipment List, July 2006)

Approval Number	Manufacturer	Item Description	Usage	S (mm)
164.107/0001/0	THERMAL CERAMICS	"FireMaster Marine Blanket", Calcium Magnesium-Silicate fiber insulation, 96 kg/m ³ (6.0 lb/ft ³) nominal density Tested and approved to the IMO FTP Code, annex 1, part 3.	Aluminum Decks, 2 mm min. thickness Aluminum Bulkheads, 2 mm min. thickness	A-60: 50 A-30: 38 A-60: 50 A-30: 38
164.107/0002/0	THERMAL CERAMICS	"FireMaster Marine Blanket", Calcium Magnesium-Silicate fiber insulation, 96 kg/m ³ (6.0 lb/ft ³) nominal density, 63 mm thick.	Aluminum Bulkheads, 5 mm min. thickness	A-60: 63
164.107/0003/0	AMERICAN SPRAYED FIBERS, INC.	Type "Dendamix" sprayed fiber approved as meeting Parts 1 and 3 of Annex I of the IMO FTP Code in nominal density of 112 kg/m ³ (7 lb/cu. ft ³)	Bulkhead Insulation	A-60: 45 Stiffeners, 18
164.107/0004/0	AMERICAN SPRAYED FIBERS, INC.	Type "Dendamix" sprayed fiber approved as meeting Parts 1 and 3 of Annex I of the IMO FTP Code in nominal. density of 112 kg/m ³ (7 lb/ft ³)	Deck (horizontal application below the deck)	A-60: 17.5

Approval Number	Manufacturer	Item Description	Usage	S (mm)
<u>164.107/0005/0</u>	<u>ROCK WOOL MANUFACTURING CO</u>	Type "Delta Marine Board" mineral wool approved as meeting Parts 1 and 3 of Annex I of the IMO FTP Code in nominal density of 112 to 128 kg/m ³ (7 to 8 lb/ ft ³)	Bulkhead Insulation (vertical application)	A-60: 76 Stiffeners: 38
<u>164.107/0006/0</u>	<u>ROCK WOOL MANUFACTURING CO</u>	"Delta Marine Board" mineral wool approved as meeting Parts 1 and 3 of Annex 1 of the IMO FTP Code in nominal density of 112 to 128 kg/m ³ (7 to 8 lb/ ft ³)	Deck Insulation (horizontal applications)	A-60: 50 Stiffeners: 25
<u>164.107/0007/0</u>	<u>AMERICAN SPRAYED FIBERS, INC.</u>	Type "Dendamix Marine" sprayed fiber insulation approved as meeting Parts 1 and 3 of Annex 1 of the IMO FTP Code in nominal density of 156 kg/m ³ (9.7 lb/ft ³)	Underneath Aluminum Decks (horizontal application)	A-60: 25.4 A-30: 1.3 Stiffeners: same thickness
<u>164.107/0008/0</u>	<u>AMERICAN SPRAYED FIBERS, INC.</u>	Type "Dendamix Marine" sprayed fiber insulation approved as meeting Parts 1 and 3 of Annex 1 of the IMO FTP Code in nominal density of 156 kg/m ³ (9.7 lb/ft ³)	Aluminum Bulkheads (vertical application)	A-60: 50.8 Stiffeners: same thickness

U.S. Coast Guard Approved Fire Protection (Cont.)

- Example of S values
- Thermal Ceramics Firemaster Marine Blanket
 - S value of 50 mm on an aluminum bulkhead
 - 50 mm provides 60 minutes of protection (A-60)
- The American Sprayed Fibers Dendamix has an S value of 45 mm

SNAME T&R Bulletin 2-21

- Time that layer of insulation can prevent rise of temperature
- Proportional to the square of the thickness
- Total insulation F_T
 - Insulating value of the side of the structure exposed to the fire is F_E ,
 - Value of the unexposed side is F_U
 - Total value of the insulation, $F_T = F_E + F_U$
- S values that provide less than 60 minutes of protection are given in table

Minimum F_T Values Required to Limit the Temperature Rise on the Unexposed Face (SNAME, 1974)

Insulating Period (minutes)	Minimum F_T as a Fraction of S
0	0.00
15	0.50
30	0.70
45	0.86
60	1.00

SNAME T&R Bulletin 2-21 (Cont.)

- Air space
 - Air space of at least 25 mm (1 inch) between the structure and a joiner bulkhead material or other fireproof sheathing,
 - Contribution to the insulation value is given by the air space
 - Depending on the orientation
 - Type of sheathing
 - Type of insulation on the structure (if any),
 - Insulation value can range between 0.0S and 0.15S
 - Figures in the T&R bulletin

SNAME T&R Bulletin 2-21 (Cont.)

- Air space provided by two types of sheathing
 - Steel, which may be perforated
 - Perforations do not exceed 25 percent of the surface area
 - At least 16 gauge (1.2903 mm, 0.0508 in) and supported by steel members
 - Joiner bulkhead work in accordance with 64 CFR 164.008
 - Minimum requirement is that the panels be incombustible
 - Panels used in Class B-15 construction
 - Component in Class A-30 or Class A-15 construction
 - Capable of passing an ASTM fire test
 - Average temperature on unexposed surface not rising more than 139 °C. (282 °F.)
 - Temperature at any point on the surface, including any joint
 - Should not rise more than 225 °C (405 °F) after 15 minutes
 - Withstand the passage of flame for at least 30 minutes
 - Panels in Class A-60 construction
 - Meet the same thermal insulation requirements as for Class B-15
 - Withstand the passage of flame for at least 60 minutes

Air space requirements (Cont.)

- Two types of insulation for air space
 - Fire protection insulation
- Thermal insulation provided for normal heating and air conditioning
 - Thermal insulation noncombustible
 - In accordance with the requirements of 46 CFR 164.009
 - Requires a furnace test at 750 °C (1,380 °F)

Air space requirements (Cont.)

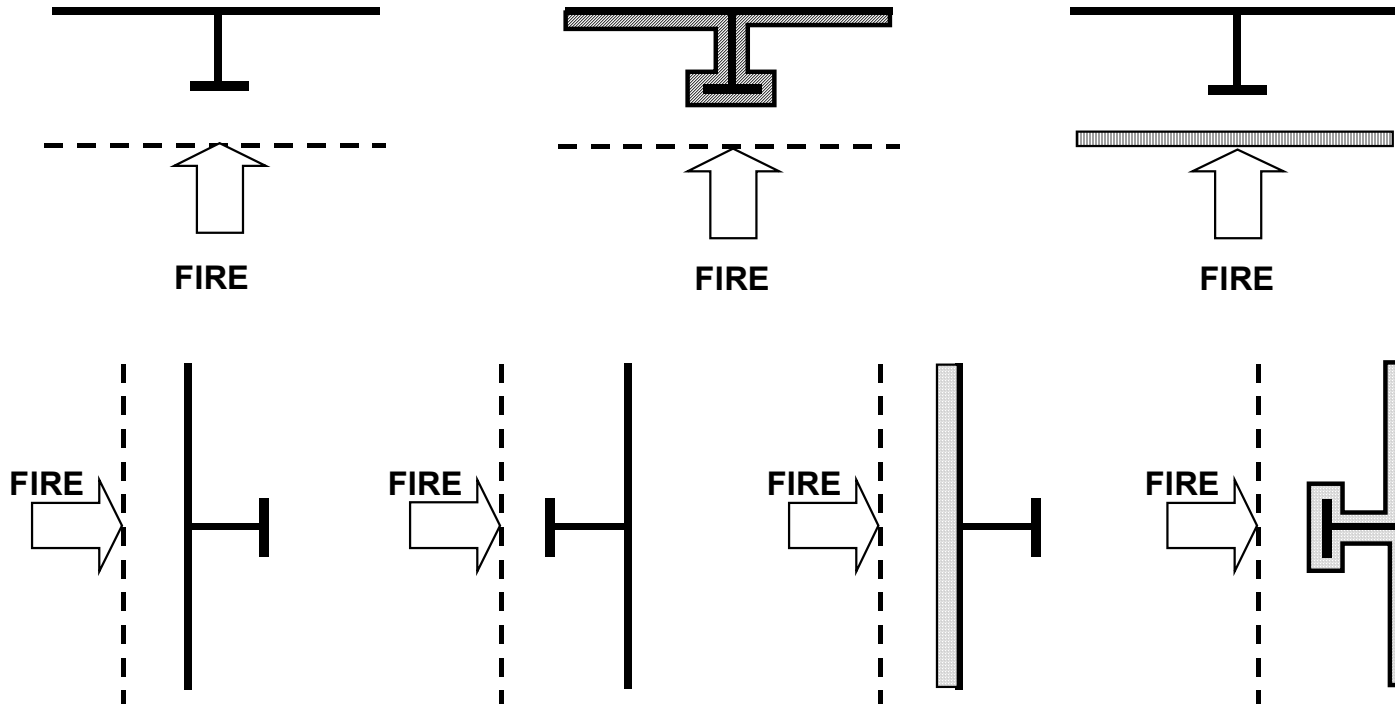

Notes:

Air space must be at least 25 mm

— — — Steel lining, either solid or perforated with less than 25% open

Structural fire protection approved iaw 64 CFR 164.007

Joiner bulkhead panels approved iaw 64 CFR 164.008

Thermal insulation approved iaw 64 CFR 164.009

Air spaces with insulating value of 0.0 S (SNAME 1974)

Air space requirements (Cont.)

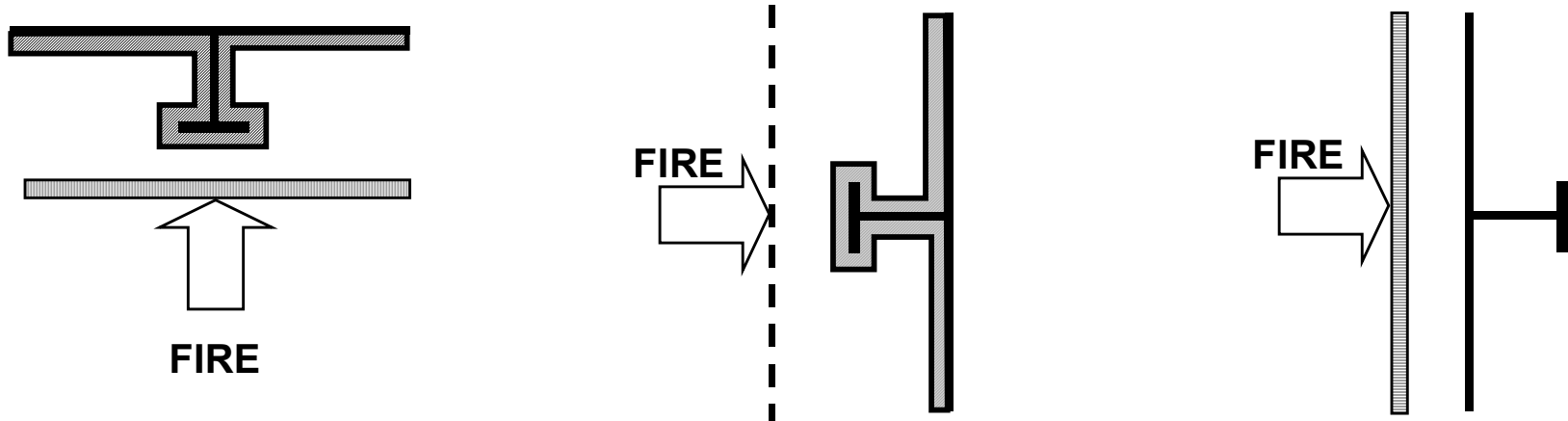

Notes:

Air space must be at least 25 mm

- Steel lining, either solid or perforated with less than 25% open
- Structural fire protection approved iaw 64 CFR 164.007
- Joiner bulkhead panels approved iaw 64 CFR 164.008
- Thermal insulation approved iaw 64 CFR 164.009

Air spaces with insulating value of 0.05 S (SNAME 1974)

Air space requirements (Cont.)

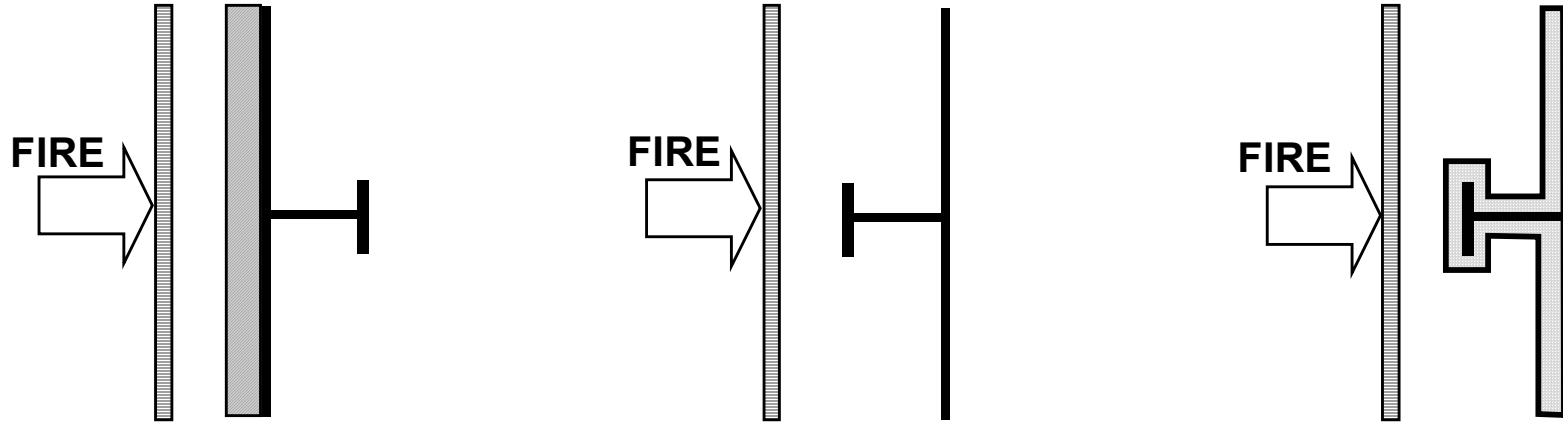

Notes:

Air space must be at least 25 mm

 Structural fire protection approved iaw 64 CFR 164.007

 Joiner bulkhead panels approved iaw 64 CFR 164.008

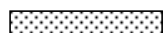
 Thermal insulation approved iaw 64 CFR 164.009

Air spaces with insulating value of 0.10 S (SNAME 1974)

Air space requirements (Cont.)

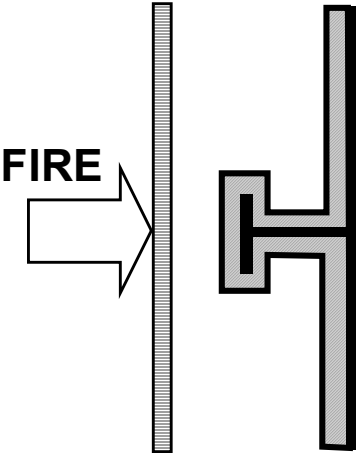

Notes:

Air space must be at least 25 mm

 Structural fire protection approved iaw 64 CFR 164.007

 Joiner bulkhead panels approved iaw 64 CFR 164.008

Air spaces with insulating value of 0.15 S (SNAME 1974)

Insulation to Protect the Aluminum Structure

- Goal that the temperature rise of aluminum no greater than 200 °C (360 °F) above ambient
 - Assumption that the ambient temperature is 30 °C (86 °F)
 - Temperature of the aluminum is no greater than 230 °C (446 °F)
- Insulation with a value of 1.0 S
 - Intended to prevent a temperature rise of 260 °C
 - Requirements for protection of aluminum are more demanding
 - Insulation prevents transmission of heat
 - Insulation on unexposed side
 - Reduces effectiveness of insulation on exposed side
 - Minimum insulation requirements for exposed side
 - For installations with no insulation on unexposed side
 - Tabulated values provide required value of insulation on exposed side
- F_E , in terms of fraction of S
- Example: 60 minutes of protection is desired
 - $F_E = 0.72 S$
 - If insulation with an S value of 55 mm is used
 - Required thickness is $0.72 \times 55 = 40$ mm

**F_E Values to Limit Temperature Rise of Aluminum Structure to 200 °C (360 °F)
(SNAME, 1974)**

Insulating Period (minutes)	Minimum F_E Values (Fraction of S)
0	0.00
15	0.25
30	0.45
45	0.61
60	0.72

- If unexposed side insulated to value F_U
 - o Value of insulation on exposed side, F_E
 - o Reduced to value protecting the core, F_C, by the equation:

$$F_C = F_E - f F_U^2$$

- f is an experimentally determined factor
 - o Depends on extent of insulation on unexposed side
 - o If 25 mm or more fire protection insulation on unexposed side, f = 0.1,
 - Otherwise, f = 0.5
- Values of F_E and F_U should include air gap, if present
 - o Especially on the unexposed side of the structure

Insulation to Protect the Aluminum Structure (Cont.)

Example of fire protection

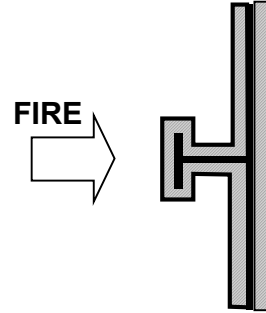

- Example: insulation on both sides with a value of 1.0 S
 - Thickness greater than 25mm
 - $F_E = 1.0$ S
 - $F_U = 1.0$ S
 - $f = 0.1$, and
 - $F_C = 1.0 - 0.1 (1.0)^2 = 0.9$ S
- Protection of the aluminum for 60 minutes requires F_C to be 0.70 S
 - Sufficient protection provided for aluminum structure
 - Total insulation value of the system is $F_T = F_E + F_U = 1.0 + 1.0 = 2.0$ S
- Lesser amounts of insulation can be used to provide protection for the aluminum and prevent the spread of heat
- Requirements based on aluminum with minimum thickness of 4.8 mm (0.18 in)
 - Thinner material will require special consideration

Insulation to Protect the Aluminum Structure (Cont.)

- Generally stiffeners have insulation surrounding
 - Same thickness as required for deck or bulkhead they support
- Consideration should be made for exceptionally deep members
 - Heat cannot be conducted back to the plate that is supported
 - No data on how deep a member must be before additional insulation is required
 - Such members should be insulated using the FC values for aluminum surrounded by fire
- Stiffening members need have only one-half the thickness of the insulation on the plate that they support if they are located behind an insulating panel with an insulating value of at least $2/3 S$.

Aluminum Surrounded by Fire

- Stanchions, pillars and other structure surrounded by fire
 - Require greater insulation than structure with fire on one side only
 - Required insulation F_C for such structure not based on experimental data
 - Based on judgment
 - Air space may be included when calculating value of insulation
- If structural bulkhead critical to support of structure above
 - Could conceivably become engulfed by a fire
 - It should be insulated as if it were a stanchion

F_C Values to Limit Temperature Rise of Aluminum Structure Surrounded by Fire to 200 °C (360 °F) (SNAME, 1974)

Insulating Period (minutes)	Minimum F_C Values (Fraction of S)
0	0.00
15	0.50
30	0.90
45	1.20
60	1.40

Insulation to Meet U.S. Navy Requirements

- Thermal Ceramics Structo-Guard approved by U.S. Navy
 - Made from a calcium-magnesium-silicate fiber
 - Manufacturer states
 - FB material meets 46 CFR 164.007/70 structural fire protection testing for A-30
 - FC material meets testing requirements for A-60
 - Product has a NAVSEA rating of N-30
 - If bulkhead insulated with two 38-mm (1.5-inch) thick layers on one the fire side
 - Insulation weighs 96 kg / m³ (6 lb / ft³)
 - Is installed with an adhesive layer
 - Barrier meeting N-30 on one side would weigh 9.45 kg/ m² (1.94 lb / ft²)
 - If both side of a bulkhead need to be insulated
 - Total of 152 mm (6 inches) of insulation is required
 - Barrier meeting N-30 would weigh 18.9 kg/ m² (3.88 lb / ft²)
- U.S. Navy shock testing required with insulation installed prior to the fire test

Alternative Design Approach

- Instead of following rules described above to determine insulation requirements
 - Fire load calculations may be made
 - Determine needed fire protection insulation
- This approach is described in SNAME T&R Bulletin 2-21
 - Approved in U.S. Coast Guard NVIC 9-97
- Approach can be advantageous for compartments that have a very small fire load
 - Passenger seating areas with simple furniture and little other flammable materials
- Design approach does not change assumed temperatures and intensity of fire
 - Only changes the duration

Alternative Design Approach (Cont.)

- First step: determine which compartments are to be separated by fire boundaries
 - o Following general guidelines apply:
 1. Spaces of unlike character, such as a stateroom and a corridor, must be separated by effective fire boundaries
 - Exceptions include spaces directly associated with each other
 - Head associated with a stateroom or pantry next to a galley
 2. On passenger ships, like compartments, such as adjacent staterooms, must be separated from each other
 3. On cargo ships, several like compartments, such as adjacent staterooms, may be combined with each other as long as the combined area of each combined space does not exceed 50 m² (538 ft²).
- Second step
 - o Calculate the total deck area of each compartment
 - o Calculate fire load of each compartment
 - Items may be considered as having the same heat of combustion of wood,
 - 4,450 k cal/kg (8,000 BTU/lb)
 - o Unless they have unusually high or low heat of combustion

Alternative Design Approach (Cont.)

The following items should be included:

1. Fixed Items. Wall and overhead linings, deck coverings, electrical wiring insulation, light diffusers, moldings, and similar items should be included.
 2. Furnishings. Include all furniture, mattresses, curtains, decorations, and similar items.
 3. Contents. Clothing and personal effects are included in staterooms as 7.32 kg/m^2 (1.5 lb.ft^2) and for public spaces, 0.732 kg/m^2 (0.15 lb.ft^2). Include life jackets, cargo, stores, paper and books in offices, and similar items.
- Weight of all combustibles divided by the area = fire loading
 - o All similar compartments considered as having same fire load
 - Such as staterooms of a similar nature
 - Typical values of fire loading for typical compartments given in Table 10-1
 - o For certain spaces shown in the table, minimum values are given.

**Table 10-1: Typical Fire Loading of Various Spaces
(SNAME, 1974)**

Space	Fire Load (kg/m ² / lbs/ft ²)
Control Spaces:	
Wheelhouse/ Chartroom	7.32 / 1.5
Fire Control Stations	7.32 / 1.5
Escape Routes	
Corridors	7.32 / 1.5
Stairway Enclosures	4.88 / 1.0
Accommodation Spaces ¹	
Staterooms:	
Fire resistant furnishings	14.65 / 3.0
Combustible furnishings	24.41 / 5.0
Public Spaces:	
Fire resistant furnishings in lounges, restaurants, etc.	14.65 / 3.0
Ferry vessels	7.32 / 1.5
Combustible furnishings	24.41 / 5.0
Restrooms not part of staterooms	1.95 / 0.4

Table 10-2: Typical Fire Loading of Various Spaces (Cont.)

Space	Fire Load (kg/m ² / lbs/ft ²)
Service Spaces	
Galleys	48.82 / 10.0
Pantries with no food heating appliances	19.53 / 4.0*
Food concessions on ferry vessels with no combustible storage	7.32 / 1.5
Workshops	48.82 / 10.0*
Storerooms	
Combustible	14.65 / 3.0
Cleaning gear only	
Laundries	48.82 / 10.0*
Ship's laundry	7.32 / 1.5
Private use	
Main Machinery and Cargo Spaces	48.82 / 10.0
Auxiliary Machinery Rooms (Fan Rooms, etc.)	24.41 / 5.0
Tanks and Voids	0.0

‡ Allowance is made for personal effects as follows:

1. Staterooms: 7.32 kg/m² (1.5 lb/ft²)
2. Public spaces: 0.732 kg/m² (0.15 lb/ft²)

* Fire loading for typical compartments so marked may not differ from typical values shown.

Alternative Design Approach (Cont.)

- To find the required time of an equivalent standard fire
 - Table 10-3 is used with only 15-minute increments considered
 - Table includes margin of safety for additional items not included in fire load
 - Sliding scale
 - Greater for lower fire loadings
 - Is 10 percent for 24.41 kg/m^2 (5.0 lbs/ft^2)

Table 10-3: Equivalent of Fire Loading to Duration of the Standard Fire Test (SNAME, 1974)

Fire Load (kg/m^2 / lbs/ft^2)	Time of Equivalent Standard Fire (minutes)
Less than 2.44 (0.5)	0
2.44 to 9.75 (0.5 to 1.99)	15
9.76 to 21.96 (2.0 to 4.59)	30
21.97 to 34.16 (4.5 to 6.99)	45
34.17 (7.0) and greater	60

Alternative Design Approach (Cont.)

- With duration of fire determined
 - Required insulation values are determined using Table 10-4
 - Insulation sufficient to protect structure in accordance with these calculations
 - Will be sufficient unless known flammable items exist on opposite side of structure
- If that is the case, total insulation should be provided to meet the requirements
 - Based on the calculated time of an equivalent fire

Table 10-4: F_C Values Required for Structure (SNAME, 1974)

Fire Load (lbs/ft²)	F_C Required as a fraction of S
Less than 0.5	0
0.5 to 1.99	0.25
2.0 to 4.99	0.45
4.5 to 6.99	0.61
7.0 and greater	0.72

Support of Insulation

- Supporting members must withstand heat of fire to which exposed
 - If pins are used that are welded to the aluminum structure
 - Must be bimetallic steel pins with an aluminum base
 - Using steel speed clips to hold the insulation
 - If insulation located entirely behind insulating panels
 - All-aluminum pins and speed clips may be used
- Insulating panels must be supported with steel supports
 - Or equivalent that can withstand the intensity of a fire
- Bulkhead panels can be supported by steel members attached to the deck
 - Separated by a dielectric material to minimize the possibility of corrosion
- Supports at top of bulkhead panels must be protected by overhead sheathing
 - Or other insulation to be certain they will not be exposed to the fire

Research in Fire Protection Materials

- All materials reviewed show promise
 - Have not been approved by regulatory bodies
 - Some of the test methods used are not standard.
- Green (2005) studied a sprayed fire protection material
 - Low-cost test developed to simulate dynamic forces acting on ship structural panels
 - Materials evaluated on aluminum structure:
 - Isolatek International Cafco Blaze Shield II
 - Span-World Distribution Temp-Coat 101 and Fyre Sheild
 - Superior Products SP2001F Fire Retardant
 - Carboline Intumastic 285
 - Materials tested not listed on U.S. Coast Guard approved material list
 - To test of durability of the materials 6 in, x 72 in. aluminum panels were made
 - Fatigue tested by flexing panels for 100,000 cycles
 - Subjected to impact loading by a dropped weight
 - Produced 50 foot-pounds of energy
 - After the fatigue testing all of the aluminum panels retained protective coating
 - Except for the SP2001F
 - Drop weight testing dislodged most of the coatings
 - Except for Intumastic 285
 - No fire testing part of program

Research in Fire Protection Materials (Cont.)

- Report by (ALCAN, 2004)
 - o Fibrofax, made from synthetic vitreous fibers (of silicates) of random orientation
 - Percentage by weight of alkaline oxides and alkaline-earth oxides ($\text{Na}_2\text{O} + \text{K}_2\text{O} + \text{MgO} + \text{BaO}$) exceeds 18%
 - o Fibrofax is 38 mm thick and weighs 3.65 kg / m² (0.228 lb / ft²) for A-30 protection
 - o 50 mm thick and 4.80 kg/m² (0.30 lb / ft²) for A-60 protection
- National Shipbuilding Research Program (NSRP, 2001)
 - o Study of improved fire protection insulation for aluminum structure
 - Aimed particularly at the vehicle deck of ferries
 - o Product studied weighs between 0.2 to 0.4 lbs/ft² (1.0 to 2.0 kg/m²)
 - o Have an installed cost ranging from \$0.07 to \$1.00 per square foot

Summary of Fire Protection

- Aluminum must be protected from the heat of a fire
 - Requires more fire protection insulation than does steel
- Requirements for fire protection set out by
 - SOLAS
 - IMO
 - IMO High Speed Craft Code
 - U.S. Coast Guard
 - Classification societies
 - Naval authorities
- SNAME T&R Bulletin 2-21
 - Provides a methodology for designing structural fire protection systems
 - Bulletin issued more than 30 years ago
 - Should be updated
 - Recommended testing should be conducted
 - Including structure that is surrounded by fire

Chapter 11

Vibration

- Sources of harmonic energy that can excite the structure into vibratory motion
 - Propulsion train
 - Other machinery
 - Hull slamming loads
- Hull structure is efficient transmitter of energy
 - Source of vibration energy at one end of ship can excite vibration at other end
 - If natural frequency of vibration of structure close to frequency of forcing function
 - Condition known as resonance.
- To avoid vibration problems
 - Avoid resonance
 - Usually means having higher frequency of structure than forcing function
 - If resonance cannot be avoided and vibration levels are unacceptable
 - Apply damping materials to structure reduces amplitude of vibration
 - Damping materials will absorb some of energy of vibration, reducing amplitude
 - Provide vibration isolation mounts for machinery
 - Better method that reduces weight impact of damping materials

Vibration Problems in Aluminum

- Vibration problems can be more acute in aluminum structure than in steel
 - Aluminum has greater potential for fatigue damage
- Structural details located can develop fatigue cracks if structure vibrates significantly
- Vibration in structure can cause unpleasant and sometimes excessive noise
 - Especially in accommodation areas
- Can reduce confidence in seaworthiness of vessel

Computing Vibration Frequencies

Single Degree of Freedom System

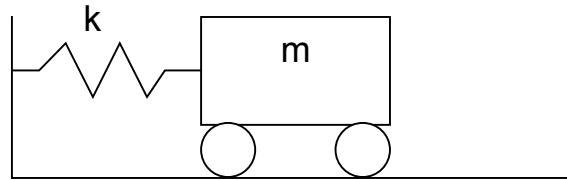

Figure 11-1: Single degree of freedom system.

$$f = \frac{1}{2\pi} \sqrt{\frac{k}{m}}$$

(11-1)

Where

m = the mass that is vibrating, and

k = the stiffness of the massless spring connected to the mass.

- Can use simple equation if mass and stiffness can be determined
 - o Generally not trivial because of the complex nature of ship structure
 - Can have thousands of degrees of freedom
 - Mass is distributed throughout the system

Beam Vibrations

Natural frequency of uniform beam with differing conditions of end restraint

$$f = \frac{C}{2\pi L^2} \sqrt{\frac{EI}{\mu}}$$

(11-2)

Where for aluminum:

f = natural frequency of vibration in Hertz

L = length of the beam in mm (inches)

E = modulus of elasticity = 71×10^6 kg / mm sec² (10.3×10^6 psi)

I = moment of inertia of the beam in mm⁴ (in⁴)

μ = mass per unit length in kg/mm (lb-sec²/in²)

C = coefficient dependent on end conditions, given in Table 11-1.

E_a , of aluminum = 71×10^3 MPa = 71×10^3 Newtons / millimeter²

Newton = force required to accelerate one kilogram at one meter per second²

10^{-3} Newtons required to accelerate one kilogram at one millimeter per second²

$1 \text{ N} = 10^3 \cdot \text{kg mm / sec}^2$

Therefore, $E_a = 71 \times 10^6$ kg / mm sec²

For steel, $E_s = 206 \times 10^3$ MPa = 206×10^6 kg / mm sec²

Table 11-1: Coefficients for Natural Frequencies of Beams (McGoldrick, 1957) and (Hurty and Rubinstein, 1964)

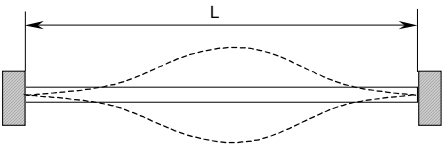
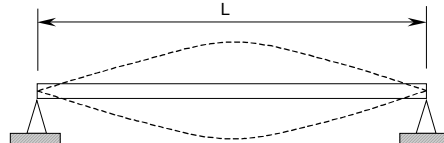
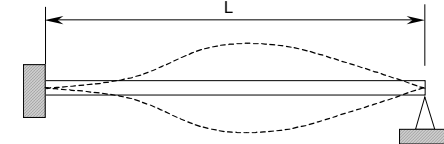
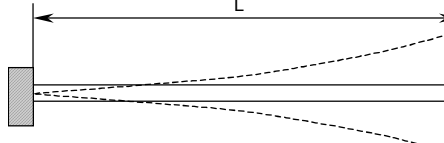
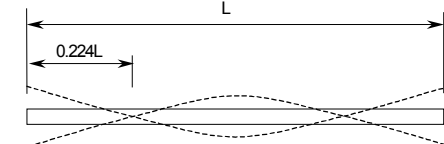
End Fixity	Coefficient (C)				Sketch of first mode
	Mode (n)				
	1	2	3	n>3	
Fixed-fixed	22.4	61.7	121	$\left(\frac{(2n+1)\pi}{2}\right)^2$	
Pinned-pinned	π^2	$(\frac{2\pi}{2})$	$(\frac{3\pi}{2})$	$(n\pi)^2$	
Fixed-pinned	15.4	50.0	104	$\left(\frac{(4n+1)\pi}{4}\right)^2$	
Canti-lever	$0.36 \pi^2$	22.0	61.7	$\left(\frac{(2n-1)\pi}{2}\right)^2$	
Free-free	22.4	61.7	121	$\left(\frac{(2n+1)\pi}{2}\right)^2$	

Vibration of Beams (Cont.)

- For stiffness inertia of plate-beam combination for vibration calculations
 - Effective plate computed using only shear lag considerations
 - Vibrations occur with relatively small displacements
 - Compared to the load capacity of the structure
 - Plasticity or buckling considerations not used to in determine effective plate
 - Effective plate should be either:
 - Stiffener spacing
 - One-third the span
 - Whichever is less
- For computing mass per unit length
 - Full width of the plate should be used
 - Any dead weight, including paint and insulation, deck coverings
 - Stores and cargo that will move with the structure
 - Equipment or machinery attached to structure included in mass calculation
 - Distribute mass of such items if possible
 - Average mass per length should be used
- If mass is concentrated in a small area
 - Use one of equations below for lumped mass should be used
 - Detailed finite element calculations may be required

Vibration of Beams (Cont.)

- Stiffeners continuous through supporting frames
 - Assume simply supported ends
 - Unless supporting structure heavy enough to justify assumption of fixity
 - As stiffener on one side of the support moves up
 - Stiffener on the other side will move in the opposite direction
 - Acts as if no restraint on rotation at supports
- If structure part of hull adjacent to water
 - Or is part of a tank boundary
 - Added mass of fluids should added to mass
 - Take added mass of liquids = mass of a half-cylinder of the liquid
 - Diameter = width of panel
 - Length equal to length of panel
 - If fluid on both sides
 - Full cylinder of liquids should be used

Uniform Beams with a Lumped Mass

Simply supported beam with a concentrated mass, m , in the center

$$f = 1.1 \sqrt{\frac{EI}{\left(m + \frac{17}{35} \mu L\right) L^3}} \quad (11-3)$$

Cantilevered beam with a concentrated mass, m , at the end, the frequency is given by:

$$f = 0.28 \sqrt{\frac{EI}{\left(m + \frac{33}{140} \mu L\right) L^3}} \quad (11-4)$$

- If single lumped mass significantly greater than the mass of structure
 - Approximate natural frequency
 - Treat as single degree of freedom system and applying equation (11-1)
 - Find stiffness of system by applying a unit force in direction of motion
 - Solve for deflection
 - Stiffness = force / deflection

Uniform Plate with Simply Supported Edges

Uniform plate with simply supported edges

First mode and higher modes

$$f = \frac{\pi}{2} \left(\frac{p^2}{a^2} + \frac{n^2}{b^2} \right) \sqrt{\frac{E t^3}{12 m (1 - \nu^2)}} \quad (11-5)$$

Where:

a, b, and t are the length, width, and thickness of the plate, respectively,

m = the mass per unit area of the plate, and

p and n are 1 less than the number of nodes in the direction of length and width, respectively

For the first mode of vibration, p = n = 1.

Uniform Plate with Simply Supported Edges (Cont.)

- Simply supported plate in Figure 11-2
 - Two nodes in the direction of length, $p = 1$
 - Three nodes in the direction of width, $n = 2$

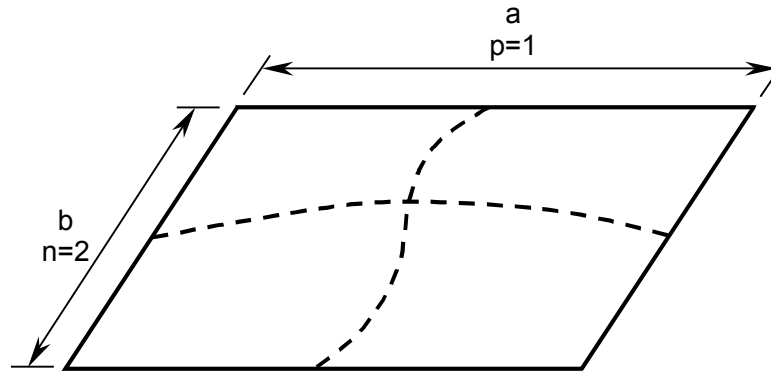

Figure 11-2: Simply supported plate vibrating

- Plates are capable of vibrating in many higher modes
 - Higher modes generally do not show significant amplitude
- Simple supports at edges
 - Adjacent plates of same size and thickness
 - Will vibrate with same pattern in opposite directions
- More complex geometries and changes in plate thickness require finite element analysis

Continuous Structural Systems

- Analysis of vibration of larger portions of structure may require finite element modeling
- Most finite element computer programs
 - Include routines for computing the natural frequencies of vibration of structure
 - Often called eigenvalues
 - Programs will determine shapes of different modes of vibration
 - Also called eigenvectors
 - Mode shapes important for understanding portion of structure that is moving the most
 - Determining points that do not move at all, called nodes
- May have to model dynamic characteristics of cargo or other systems

Propellers on Vessels with Conventional Propulsion

- As propeller turns uneven forces on the hull at the frequency of shaft rotation
 - Any unbalance in the weight of the propeller
 - Lack of straightness of the propeller shaft
 - Hydrodynamic unbalance between the blades
- Propeller shaft rotating at 300 rpm will have a shaft-rate frequency of 5 Hz
- Most structural systems have natural frequencies greater than this
 - Resonance avoidance is not an issue
- Large massive items of the structure often have natural frequencies of 5 Hz or less
 - Mast or a deckhouse
 - Hull girder has low frequencies
 - First mode of hull girder vibration generally in the 1 to 2 Hz range
 - Difficult to significantly change the natural frequencies of such systems
- Fixed-pitch propellers operate at a variety of shaft rates
 - Resonance with the hull girder or massive portions of structure
 - Over some range of shaft speeds generally cannot be avoided
 - Ensure shaft is straight and well aligned
 - Propeller itself is well balanced both statically and dynamically
 - Resonances will occur, but forces may not be high enough to cause vibration problems

Propeller Blade-Rate Excitation

- Propeller usually operates in an uneven flow field
 - Forces on individual blades vary as shaft rotates
 - Clearance between blade tips and hull and nearby appendages
- Cavitating or semi-cavitating propeller
 - Uneven forces at blade rate
 - Degree of cavitation increases and decreases in flow field
 - Changes in the depth as shaft rotates
- Frequency of blade-rate excitation = shaft speed times number of propeller blades
 - A 3-bladed propeller operating at 300 rpm
 - Blade-rate frequency = $300 \times 3 / 60 = 15$ Hz
 - If five blades, frequency = 25 Hz
- Easier to make structure frequency greater than 15 Hz simpler than 25 Hz
 - Contradiction: blade-rate forces on 5-bladed propeller less than on 3-bladed propeller
 - Strict resonance avoidance doesn't always result in the lowest levels of vibration
- Resonance avoidance is possible with slow to medium shaft speeds
- High-speed shafts with supercavitating propellers shaft speeds as high as 9,000 rpm
 - Avoidance of shaft-rate and blade-rate resonance unavoidable
 - Vibration reduction from well-supported and aligned propulsion system
 - Requires excellent balance in the system

Waterjets or Ducted Propellers

- Exciting forces different from conventional propellers
 - Often have high energy levels
 - Especially for high-speed vessels
- Significant source of vibratory energy.

Hull Girder Whipping

- Various modes of hull girder vibration
 - Excited by slamming and sometimes ordinary wave encounter
- Hull vibrates as a free-free beam in vertical, lateral, and torsional modes
 - Generally not a problem in itself
 - Additional fatigue cycles imposed on the hull structure
- Frequency of significant modes of hull vibration range 1 Hz to about 10 Hz
- If significant portion of the vessel resonates with one of these hull modes
 - Significant amplitudes of vibration can occur
 - Deckhouse or mast
- Schlick's empirical formula:

$$N = C \sqrt{\frac{I_H}{\Delta L^3}}$$

(11-6)

where:

N = frequency in cycles per minute,

C = empirical constant, varying between 1.28×10^5 to 1.57×10^5 ,

I_H = Inertia of the hull girder in feet² inches²,

Δ = displacement in long tons, and

L = length between perpendiculars in feet

Hull Girder Whipping (Cont.)

- Burrill's empirical formula:

$$N = \frac{\phi \sqrt{\frac{I_H}{\Delta L^3}}}{\sqrt{\left(1 + \frac{B}{2d}\right)(1+r)}} \quad (11-7)$$

Where the symbols are the same as in Schlick's formula and:

ϕ = empirical constant = 24×10^5 ,

B = beam of ship in feet,

d = draft in feet, and

r = Lockwood Taylor's shear correction factor:

$$r = \frac{3.5 D^2 (3 a^3 + 9 a^2 + 6 a + 1.2)}{L^2 (3 a + 1)} \quad (11-8)$$

Where:

a = B / D, and

D = depth of hull in feet.

Hull Girder Whipping (Cont.)

- Both formulae developed for steel hulls
 - Inertia of the hull girder, I_H , should be divided by 3 for aluminum
 - Formulae were developed for larger ships
 - Not necessarily applicable to smaller craft
 - For such vessels, especially multi-hulled craft
 - Transverse bending (flapping) modes are important
 - Analyses using finite element modeling may be required.

Friis Hansen et al. (1995) approximate relationship for aluminum hulls:

$$\Omega_2 \approx 14.45 \sqrt{\frac{EI}{\Delta L^3}}$$

(11-9)

Damping

- Computation of structural vibratory response to forcing function
 - Beyond scope of this course
- Structural damping
- Study of a 70-meter aluminum surface effects ship (ISSC V.2, 2000)
 - Damping ratio for vertical bending = 0.014
 - Both the on-cushion and off-cushion conditions
 - Damping ratio = ratio between damping coefficient and critical damping

Energy of Vibration

- During free vibration energy is continuously transferred
 - Between strain energy of structure and kinematic energy of mass
- In complex systems transformation from one state to another is never complete
 - Always some portion of the structure in motion
 - Other portions have stored strain energy
- Simple undamped systems vibrating in a single mode
 - Harmonic motion oscillates from
 - Zero strain and maximum system velocity to
 - Zero velocity and maximum strain energy
- Strain energy, U , and kinematic energy, T , in a simple beam are equal

$$U = \frac{1}{2} \int_0^L E I \left(\frac{d^2 w}{dx^2} \right)^2 dx \quad (11-10)$$

$$T = \frac{1}{2} \int_0^L \mu \left(\frac{dw}{dt} \right)^2 dx \quad (11-11)$$

Where w = displacement of beam along its length, x , and μ is mass per unit length

Vibration of a Beam

- Rayleigh's principle
 - In a conservative system the frequency of vibration is stationary
 - Used to estimate the frequency of the first mode of vibration of a system
 - Assume a displacement function
 - Determine strain and kinematic energy by using forms of equations (11-9) and (11-10)
 - Simply supported beam of length L and frequency of vibration f,
 - Displacement, w, given by:

$$w = W \sin\left(\frac{\pi x}{L}\right) \sin(2\pi f t)$$

(11-12)

Where W is the maximum displacement

Rayleigh's principle (Cont.)

Substituting equation (11-12) into equations (11-10) and (11-11):

$$U_{\max} = \frac{E I W^2 \pi^4}{4 L^3} \quad (11-13)$$

$$T_{\max} = \mu W^2 \pi^2 f^2 L \quad (11-14)$$

- U_{\max} and T_{\max} are maximum strain and kinematic energies
- Equate U_{\max} and T_{\max} and solve for f
 - Equation (11-2) results
 - Coefficient $C = \pi^2$
 - Agrees with Table 11-1 for the first mode of vibration

Energy of Beam Vibration

- Simply supported beam vibrating in its second mode
 - Displacement shape is similar to Figure 11-3
 - Motion is anti-symmetric about center of beam
 - Vibrates as if it were two separate simply supported beams of length $L/2$

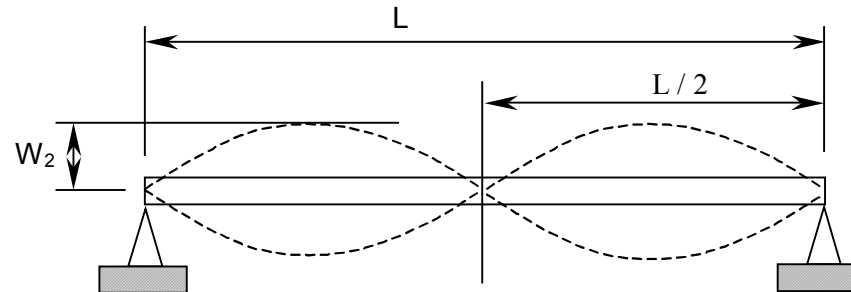

Figure 11-3: Simply supported beam vibrating in its second mode.

- Strain energy for the second mode of vibration, $U_{2 \max}$,
 - Found using equation (11-13) as:

$$U_{2 \max} = \frac{4 E I W_2^2 \pi^4}{L^3}$$

(11-15)

Energy of Beam Vibration (Cont.)

- Comparing equations (11-13) and (11-15)
 - If $U_{\max,} = U_{2 \max,}$, then $W_2 = W / 4$
 - For the same amount of energy exciting resonance
 - Response of first mode four times greater than response of second mode
 - Alternatively, sixteen times as much energy is required to excite the second mode to the same amplitude of response as the first mode
 - Ratios will differ for other structural systems, but the principle remains the same
 - Higher modes require greater energy for excitation
 - This doesn't mean that a system won't vibrate in higher modes
 - Response depends on frequency of exciting energy

Comparison of Aluminum and Steel Plates

Compare ratio of frequencies of two plates of the same dimensions but of different thicknesses in aluminum and steel equation (11-5):

$$\frac{f_a}{f_s} = \sqrt{\frac{E_a t_a^3 m_s}{E_s t_s^3 m_a}} \quad (11-16)$$

If $m_s = \rho_s t_s$, and $m_a = \rho_a t_a$, where ρ_s and ρ_a are the density of steel and aluminum, respectively:

$$\frac{f_a}{f_s} = \sqrt{\frac{E_a t_a^3 \rho_s t_s}{E_s t_s^3 \rho_a t_a}} \quad (11-17)$$

Because $E_a / E_s = 1/3$, and $\rho_s / \rho_a = 3$, equation (11-17) becomes:

$$\frac{f_a}{f_s} = \frac{t_a}{t_s} \quad (11-18)$$

Ratios of frequencies of plates are proportional to thickness of plates

Comparison of Aluminum and Steel Plates

Comparing two similar designs in aluminum and steel, a bottom plate panel in the bow of the 60-meter 50-knot craft examined by Stone (2005) had the following characteristics:

$$s = 0.26 \text{ m}$$

$$L = 0.80 \text{ m}$$

$$p = \text{design pressure by ABS HSV guide} = 222 \text{ kN/mm}^2$$

$$\sigma_a = \text{allowable stress} = 0.90 \sigma_y \text{ for both steel and aluminum.}$$

$$k = \text{factor for aspect ratio} = 0.50$$

Using 5083-H116 plate with $\sigma_y = 165 \text{ MPa}$, and HS 36 steel plate with $\sigma_y = 355 \text{ MPa}$,

$$t_a = s \sqrt{\frac{p k}{1000 \sigma_a}} = 260 \sqrt{\frac{222 \times 0.5}{1000 \times 0.90 \times 165}} = 7.1 \text{ mm}$$

And

$$t_a = s \sqrt{\frac{p k}{1000 \sigma_a}} = 260 \sqrt{\frac{222 \times 0.5}{1000 \times 0.90 \times 355}} = 4.85 \text{ mm}$$

If these thicknesses are rounded to 7.0 mm and 5.0 mm, and are used in equation (11-5) with $m_a = 2.66 \times 10^3 \text{ kg / m}^3 \times 0.007 \text{ m} = 18.6 \text{ kg / m}^2$

Comparison of Aluminum and Steel Plates (Cont.)

$$f_a = \frac{\pi}{2} \left(\frac{1}{a^2} + \frac{1}{b^2} \right) \sqrt{\frac{E_a t_a^3}{12 m_a (1 - \nu^2)}} = \frac{\pi}{2} \left(\frac{1}{0.80^2} + \frac{1}{0.26^2} \right) \sqrt{\frac{71 \times 10^9 \times (7 \times 10^{-3})^3}{12 \times 18.6 (1 - 0.3^2)}} = 281 \text{ Hz}$$

- Similarly for steel, $f_s = 200 \text{ Hz}$
 - $f_a / f_s = 281 / 200 = 1.4 = t_a / t_s$.
- In this comparative design case
 - Aluminum plate panel has natural frequency 40 % greater than frequency of equivalent steel plate.
- If dead load of $200 \text{ kg} / \text{m}^2$ ($40 \text{ lb} / \text{ft}^2$) is added to the plate
 - Masses per unit area become $m_a = 218.6 \text{ kg} / \text{m}^2$
 $m_s = 239.2 \text{ kg} / \text{m}^2$.
 - Then $f_a = 82.0 \text{ Hz}$ and $f_s = 80.8 \text{ Hz}$
 - Mass of dead load dominates
 - Increased thickness of the aluminum just compensates for its reduced elastic modulus in determining natural frequency
 - For higher dead load or other mass
 - Aluminum would have lower frequency than steel

Comparison of Aluminum and Steel Stiffeners

- Natural frequency of simply supported stiffeners from equation (11-2) and Table 11-1:

$$f = \frac{\pi}{2L^2} \sqrt{\frac{EI}{\mu}} \quad (11-19)$$

Comparing aluminum and steel:

$$\frac{f_a}{f_s} = \sqrt{\frac{E_a I_a \mu_s}{E_s I_s \mu_a}} \quad (11-20)$$

$\mu = A_x \times \rho$, where A_x is the cross-sectional area of the plate-beam combination

ρ is density of material

$$E_a / E_s = 1/3$$

$$\rho_s / \rho_a = 3$$

Equation (11-20) becomes:

$$\frac{f_a}{f_s} = \sqrt{\frac{I_a A_{xs}}{3 I_s A_{xa}}} \quad (11-21)$$

Comparison of Aluminum and Steel Stiffeners (Cont.)

Using example structure compared above for plates

For stiffeners, design pressure is 222.4 kN/m^2

Allowable stress for both aluminum and steel, $\sigma_a = 0.55 \sigma_y$

For 6061-T6 aluminum extrusions, $\sigma_y = 138 \text{ MPa}$, so

$$\sigma_a = 0.55 \times 138 = 75.9 \text{ MPa}$$

For HS 36 steel, $\sigma_y = 355 \text{ MPa}$, so $\sigma_a = 0.55 \times 355 = 195 \text{ MPa}$.

Dimensions of structure are:

$$L = 800 \text{ mm}$$

$$s = 260 \text{ mm}$$

The ABS HSC requires the section modulus to be $SM = 83.3 p s L^2 / \sigma_a$:

$$SM_a = 83.3 \times 222.4 \times 0.260 \times (0.800)^2 / 75.9 = 40.6 \text{ cm}^3$$

$$SM_s = 83.3 \times 222.4 \times 0.260 \times (0.800)^2 / 195 = 15.8 \text{ cm}^3$$

Comparison of Aluminum and Steel Stiffeners (Cont.)

- For aluminum select 3" x 3" x 1.5
 - For steel select 2.5" x 2" x 3/16" x 2.75# L
- The natural frequency of vibration of the aluminum plate-beam is then:

$$f_a = \frac{\pi}{2(800)^2} \sqrt{\frac{71 \times 10^6 \times 2.56 \times 10^6}{2.57 \times 10^{-3}}} = 395 \text{ Hz.}$$

- Natural frequency for steel section = 295 Hz
 - Equivalent aluminum has frequency 30 percent greater than steel
- Add dead weight of 200 kg/m²
 - Frequencies become 136 Hz for aluminum and 148 Hz for steel, nearly equal.

Energy of Vibration of Stiffeners

- Use equation (11-13) to find the maximum strain energy of the aluminum stiffener vibrating in its first mode with amplitude $W = 1$ mm:

$$U_{Al} = \frac{W^2 (71 \times 10^6) (2.56 \times 10^6) \pi^4}{4 (800)^2} = 8.64 \frac{\text{kg mm}^2}{\text{sec}^2} = 8.64 \text{ Joules}$$

- Energy of first mode of equivalent steel stiffener $U_{st} = 9.80$ Joules
 - Almost same energy required to excite steel and aluminum structures to same amplitude
- Energy proportional to square of amplitude
 - Amplitude of vibration of aluminum stiffener is only 6 percent greater than amplitude of steel stiffener for same energy of excitation
- If 200 kg/m^2 added as dead load
 - Results would be same
 - Mass or frequency do not enter equation (11-13)
 - If equation (11-14) for kinematic energy were used instead
 - Increased mass compensated for by lower frequency
 - Kinematic energy would remain same as strain energy
 - Difference in response would occur if forcing frequency were closer to the natural frequency of more massive system
 - Only then would the response be greater

Table 11-2: Comparison of Vibration Frequencies of Equivalent Aluminum and Steel Panels

Characteristic	Aluminum	Steel
Alloy	plate 5083-H116 stiffeners 6061-T6	HS 36
Yield Strength	plate 165 MPa stiffeners 138 MPa	355 MPa
Allowable stress	plate 148 MPa stiffeners 76 MPa	plate 320 MPa stiffeners 195 MPa
Panel size	800 mm x 260 mm	800 mm x 260 mm
Design pressure	222 kN/m ²	222 kN/m ²
Scantlings Selected	3" x 3" x 1.5# T 7 mm plate	2.5" x 2v x 3/16" L 5 mm plate
Plate Frequency (Hz)	281	200
Plate Frequency with 200 kg/m ² dead load (Hz)	82	81
Stiffener Frequency (Hz)	395	295
Stiffener Frequency with 200 kg/m ² dead load (Hz)	136	148
Energy for 1 mm amplitude vibration in first mode (Joules)	8.64	9.80

Summary of Vibration

- Natural frequencies of vibration for steel and aluminum structures similar
 - Require about the same amount of energy for excitation
- Aluminum hull
 - No more prone to vibration problems than steel hull
 - Hull girder vibration
 - Local vibration
 - Better if meet classification society requirements
 - Inertia of structural members
 - Hull girder inertia
- Aluminum structure can have more fatigue cracking problems from vibration
- Structure should be proportioned to avoid resonance with various forcing functions
 - Damping materials must be added if resonance cannot be avoided
- Hull girder vibration can be a problem
 - Simple methods needed for estimating aluminum hull girder frequencies
 - Advanced design stages of aluminum vessels.

Chapter 12

Maintenance and Repair

- Aluminum marine structures can see many years of service with minimal problems
 - Many aluminum workboats that have seen 30 and more years of satisfactory service
- Aluminum can be very prone to fatigue crack growth
 - Cracking of structure does occur
 - Aluminum deckhouses of steel-hulled ships
- Once Corrosion of aluminum is initiated
 - Tends to be rapid and concentrated
 - Requiring immediate action to restore structural integrity
 - The 5xxx-series aluminum alloys do not generally require painting to avoid corrosion
 - Improper painting procedures can lead to corrosion problems
 - Most other metals are anodic to aluminum and contact can lead to rapid wastage
 - Improper alloys, especially those containing copper, will also lead to rapid corrosion
 - Coating systems offer little protection if the aluminum is constantly exposed to seawater

Painting and Preservation

- 5xxx series marine-grade alloys do not have to be painted for service in marine environment
 - Inherent corrosion protection
 - Form an oxide film on their surface
 - Protects aluminum from further corrosion
 - When oxide film is constantly removed or disturbed
 - Progressive corrosion can take place
 - Local corrosion in regions subject to extreme scrubbing action
 - Turbulent flow adjacent to projections from underwater hulls
 - Over rudders, and similar surfaces
 - In such cases, special coatings are required
- 6xxx-series aluminum alloys used more extensively today
 - Lightweight extruded panels
 - If used in situations likely to be exposed to seawater
 - Required to be coated with an effective system to prevent corrosion
 - Most 6xxx-series stiffeners within the hull are usually bare
- Marine-grade aluminum is often painted for appearance
 - Bottom generally coated with anti-fouling paint

Preparation for Painting

- Guidance on preparation of aluminum for painting
 - Aluminum and the SEA (ALCAN, 2004)
 - Care of Aluminum, 2002, (Aluminum Association)
 - NSW Carderock aluminum guide (Beach, 1984).
- Remove oxide film that covers uncoated aluminum
 - Prevents adhesion of paints to surface
- Degreasing performed prior to other preparation procedures
 - Prevent grease and oils from becoming imbedded into surface of aluminum
 - Degreasing should remove all foreign bodies
 - Including solid particles and fatty products (oils, greases)
 - Have infiltrated the metal's natural oxide film
 - Degreasing with detergents is preferable to the use of organic solvents
 - Solvents that are too “light” such as acetone not recommended
 - Tricky to handle and highly flammable
 - Degreasing done by treating small areas at a time
 - Clean lint-free cloths that are frequently replaced
 - Ensure that impurities are removed rather than just spread around

Preparation for Painting (Cont.)

- Options for cleaning surface of aluminum
 - Etching
 - Blasting
 - Disk grinding
 - Wire brushing
- Etching involves chemically pickling the surface layer of aluminum
 - Etched surface will accept wash primer
 - Etching medium is phosphoric acid solution applied liberally to all surfaces
 - Applied with a brush, cloth, or sometimes a mop
 - Protect the operator from splashes
 - After application medium left to act as directed by the manufacturer
 - Usually for 20 to 30 minutes
 - Surfaces then washed off with fresh water
 - Until wash water returns to a neutral pH level

Preparation for Painting (Cont.)

- Blasting is done with an abrasive suitable for use on aluminum alloys
 - Aluminum oxide or any other inert abrasive
 - Avoid abrasives that will contaminate surface of aluminum
 - Copper slag or iron oxide
 - Steel shot must not be used because it can cause pitting corrosion
 - Do not use abrasives if previously used for blasting steel
 - Blasting must always be done on surfaces that are clean and dry
 - Followed by thorough dust removal
 - Preparation of aluminum should include blasting or grinding to clean silver color
- Disk grinding used on surfaces that cannot be treated by etching or abrasive cleaning
 - Must be carried out with coarse grit aluminum oxide wheels
 - Achieve a well-keyed adhesive substrate
 - Coatings do not adhere to surfaces treated in this way as well as after etching or blasting

Preparation for Painting (Cont.)

- Wire brushing
 - Should be done only
 - After the surface is thoroughly degreased beforehand
 - Completely free of grease, oil, paint, water, or other fluids or contaminants
 - Hand or power wire brushes can be used
 - If surface not properly cleaned beforehand
 - Contaminants can be worked into surface by brushes
 - Brushes must be stainless steel
 - Bristles should be about 0.25 mm (0.01 in) in diameter.
- Blasting with high-pressure water has been experimented
 - Preparation of aluminum for coating
 - Method should only be used if established procedure is followed

Painting

- Surfaces should be primed as soon as possible following preparation
 - Prevent oxide film from absorbing moisture
 - Treated surfaces from attracting impurities
 - Maximum period of four hours
- Effective protection against an aggressive marine environment
 - Obtained by multi-layer coatings
 - Each coat contributes to the efficiency of the system
- Types of paint most widely used based on polyurethane or epoxy resins
- Preferred primer for aluminum is epoxy system
 - Number available from paint manufacturers
 - Including systems produced specifically for aluminum
- Reactive primer is an alternative
 - Usually with a vinyl resin base
 - Containing phosphoric acid
- Application of primers should follow manufacturers' recommendations
 - Must always be preceded by proper preparation of aluminum
- Primer ensures that the coatings adhere to the aluminum
- Provide a seal to prevent corrosion

Painting (Cont.)

- Zinc chromate primers were formerly on marine aluminum structures
 - Zinc chromate is the most frequently used anticorrosive pigment in the formulation of primers
 - It is still used extensively today
 - Particularly in the aircraft industry
 - Offered as a primer for steel in consumer applications
 - Has been identified as a carcinogen
 - Banned for many applications, including marine use
- Different environmentally acceptable alternatives for anticorrosive pigment have been proposed to replace zinc chromate
 - Including zinc phosphate
 - Modifications have been made to this family of pigments
 - Improve its properties
- Second generation of phosphate pigments
 - Incorporating elements such as molybdenum, aluminum, or iron
 - Effectiveness not demonstrated for protection of aluminum

Painting (Cont.)

- Special fillers are used to achieve a smooth surface
 - Especially on yachts and other vessels
 - Appearance is important
 - Slight increase in weight is acceptable
 - Preference should be given to solvent-free epoxy fillers
 - Suited to immersion and will not shrink as they harden
 - Fillers should never be applied directly onto the metal
 - Between successive coats of epoxy primer
 - Application is by spatula or more often using a float
 - Once it has dried
 - Filler should be sanded using wet or dry abrasive paper
 - Some fillers may require washing with fresh water after curing
 - Especially if this occurs at low temperature
 - All dust should be carefully removed from the surface before the next coat of primer is applied

Painting (Cont.)

- Finish coats used to reinforce the water tightness of the paint system
 - Enhance its appearance
 - Variety of coatings are available
 - Polyurethane provides a very smooth appearance
 - Finish coat applied must be compatible with the primer used
 - Consult manufacturer for this information
- Antifouling paints
 - Aluminum and its mineral compounds such as alumina Al(OH)_3
 - Non-toxic to marine growth and offer no protection to a bare bottom
 - Antifouling paints based on copper oxide must be avoided
 - Can severely corrode the underlying metal
 - Tributyl tin (TBT) has been used since early 1970s
 - IMO banned TBT-based antifouling paints in 2003
 - Biocide is toxic to marine environment
 - Paint manufacturers have developed antifouling paints that are compatible with aluminum
 - Coatings are not strictly antifouling
 - They do not contain toxins that kill marine life
 - Coatings release when marine growth develops on them, keeping the hull clean

Painting (Cont.)

- Potable water tanks do not have to be coated
 - Chemical composition of 5xxx and 6xxx-series alloys
 - Considered “food-grade” materials
- Can be used uncoated to make potable water tanks
 - Before use it is essential to thoroughly clean the insides of the tanks
 - Rinse them several times, preferably with hot potable water
- Potable water tanks may also be painted if desired
 - Protection products must be supported by a manufacturer’s certificate of safety (ALCAN, 2004)
- Coatings may be required on other tanks
 - Sewage tanks and gray water tanks
 - Tanks that include acids and fats from the galley
 - Sewage and these chemicals can cause corrosion of aluminum
 - Such tanks should be coated for protection.
- The U.S. Navy provides guidance for painting aluminum
 - Chapter 631 of the Naval Ships Technical Manual
 - Recommends grit blast
 - Epoxy primer (MIL-DTL-24441 or MIL-PRF-23236)
 - Silicone alkyd topcoat (MIL-PRF-24635)
 - This system is currently being reviewed for improvement in performance

Corrosion Problems

- Lead-based paint is banned because of environmental concerns
 - Lead paint should never be used on aluminum, as it will promote corrosion
- Iron oxide primers should not be used as they also promote corrosion
- Some craft constructed with alloys that do not belong in a marine environment
 - 2xxx and 7xxx-series alloys
 - Craft, such as air cushion vehicles
 - Intended to operate in sea water for only a short time
 - Then stored in dry environment
 - Craft should be rinsed with fresh water after removal from seawater
 - Special attention paid to crevices and pockets where water can accumulate
 - They should then be thoroughly inspected for any signs of breakdown of coatings

Example of Corrosion from Wrong Primer

- Steel door frame primed before aluminum
 - Primer was either red lead or red iron oxide
 - Spilled over onto the aluminum
 - Aluminum should be sanded or blasted down to bare metal
 - At least 150 mm (6 in) from the edge
 - Ensure that all of the primer is removed

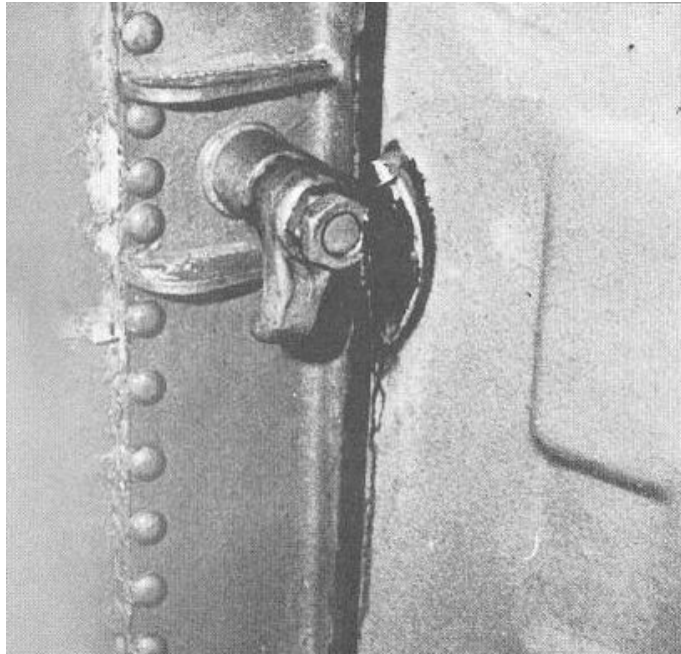
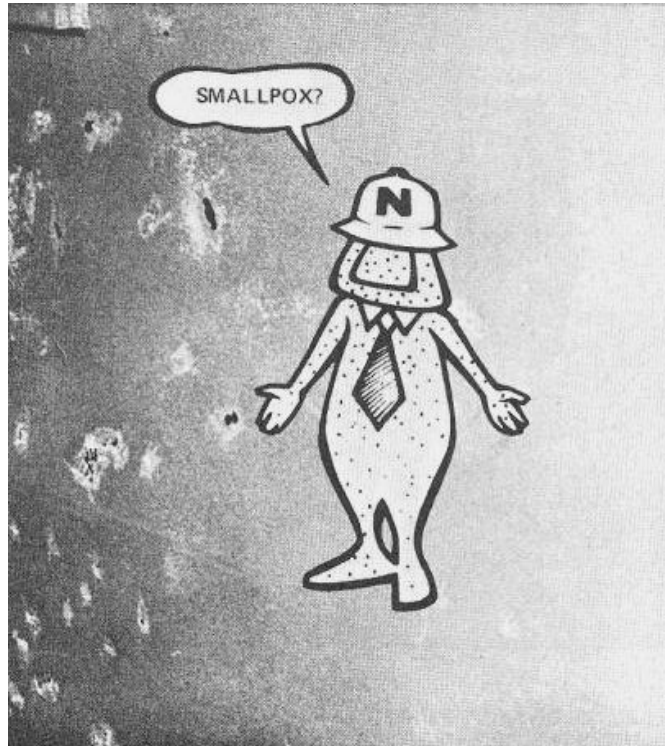

Figure 12-1: Corrosion of aluminum where lead or iron oxide primer spilled over from priming a steel door frame (Dye and Dawson, 1973).

Example of Corrosion from Wrong Primer

- Paint blistering, corrosion, and some star cracking
 - o Aluminum was primed with iron oxide
 - o Entire area must be blasted or sanded to bare metal
 - o Areas of corrosion ground out before repriming the surface



**Figure 12-2: Corrosion of aluminum primed with iron oxide
(Dye and Dawson, 1973)**

Example of Corrosion from Standing Water

- Corrosion resistance of aluminum even with effective coatings
 - May be insufficient in cases where entrapment of seawater
 - Cause high buildup of salt concentration
 - Repeated wetting and drying
- Good coating system may not protect such areas
 - Best solution is to provide drainage
- Example
 - Internal stiffener within a fan room
 - Accumulated a high salt concentration
 - Spray entering through the intake
 - Plate had been painted with zinc chromate primer
 - Before the use of that coating had been banned for environmental reasons.



Figure 12-3: Corrosion where standing water at an internal stiffener permitted buildup of salt concentrations (Dye and Dawson, 1973).

Repair of Cracking

- Three general causes of cracking in aluminum structure
 - Cracking at improper welds
 - Fatigue cracking from stress concentrations or poor structural details
 - Stress-corrosion cracking
- Difference usually determined through detailed analysis
 - Loads
 - Stresses
 - Metallurgical examination
- Detailed analysis generally impractical in repair situation
 - Characterized by little available time
- Repair situations generally done by trial-and error
 - If crack found
 - Generally in a weld or initiated in a weld
 - Safe-end the crack
 - Grind out the crack
 - Reweld
- If time permits, a through engineering evaluation should be made prior to repair
 - Especially important if same area cracks in fleet of similar vessels
 - Should always be done if failure recurs shortly after repairs are made

Repair of Cracking (Cont.)

- Investigation of cracking
 - Should include
 - Estimate of fatigue load spectrum vessel has encountered to date
 - Stress spectrum resulting from those loads
 - Linear cumulative fatigue damage calculation
 - Use assumed S-N curve for the structural detail that has cracked
 - If not possible
 - Stress concentration analysis can be made under an assumed loading
 - Redesign should significantly reduce the stress at the area of cracking
 - By 50 percent if possible
 - If that cannot be done
 - Weld fatigue strength improvement techniques should be employed

Safe-ending Cracks

- Very high stress concentration at tip of a crack
 - Aluminum has a high coefficient of thermal expansion
 - High strains develop during welding
 - Can cause the crack to continue to propagate during a repair weld
- The crack surface often has a 45-degree angle through a plate
 - Distance equal to thickness of plate
 - Can separate crack tip on opposite sides of plate
 - Tip of crack should be drilled out
 - Hole diameter equal to at least three times plate thickness
- Prior to drilling a hole to safe-end a crack
 - Plate surface should be ground clean
 - Dye penetrant should be used
 - Be certain that the crack tip has been located
- After safe-ending crack
 - Dye penetrant should be used again
 - Ensure that crack does not extend beyond hole
- If crack has propagated in two or more directions from point of crack initiation
 - All of the crack tips must be found and safe-ended

Safe-ending Cracks (Cont.)

- If time does not permit rewelding of a crack after the ends have been drilled out
 - Reaming or grinding surface of holes smooth can slow further re-cracking
 - Insert high strength stainless steel bolt with heavy washers into the opening
 - Tighten to near the breaking strength of the bolt
 - Compressive stresses from the bolt
 - Will slow the process of crack reinitiating
 - Using a polysulfide sealant can provide temporary watertightness

• Welding a Doubler Plate

- Welding a doubler plate over the crack
 - Longer lasting temporary repair
- Crack must be safe-ended before welding doubler plate
 - Corners of doubler should have minimum radius of 75 mm (3 in)
 - Edges of doubler should be at least 150 mm (6 in) from crack
- If doubler crosses a weld in the plate
 - Weld should be ground flush
 - Doubler extended at least 150 mm (6 in) beyond the weld
- Example: Note that crack has crossed stiffener web
 - Web must be examined to see if crack has propagated into it
 - If so, crack tip must be safe-ended
 - Cope hole can be ground in the web

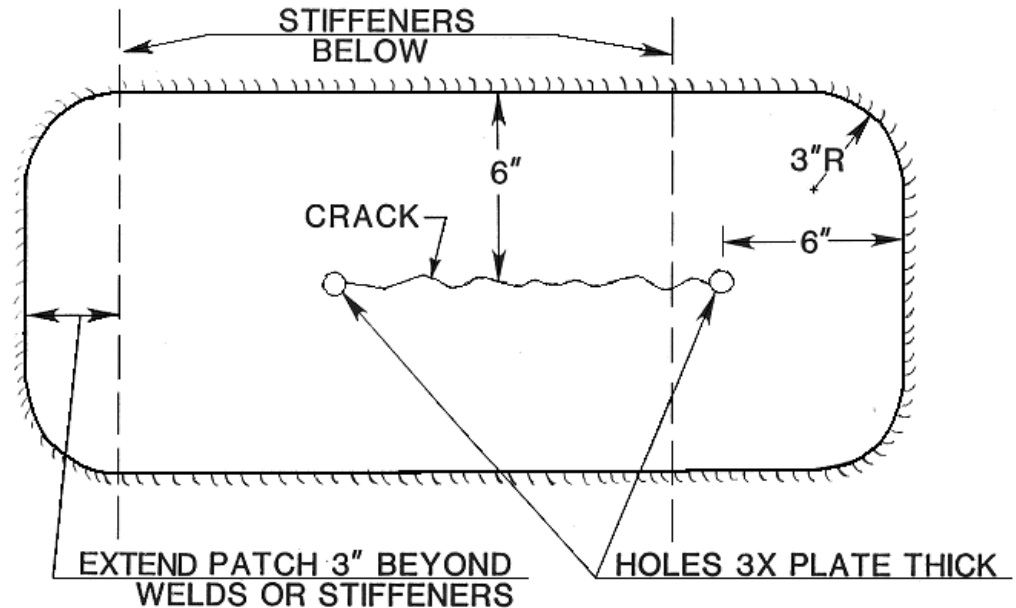

Welding a Doubler Plate (Cont.)

-
- Doubler plate may be intended as only a temporary repair
 - o Every effort should be made to use proper welding procedures
 - o Achieve as high a quality weld as possible
- To achieve additional resistance from crack initiation
 - o Edges of fillet welds of doubler can be ground smooth
- Grooming of weld profile
 - o Should not reduce thickness of the plate
 - By 10 % or 0.8 mm (0.03 in)
 - Whichever is less
- Grind perpendicular to edge of weld
 - o Grinding parallel to edge will place grooves in weld
 - Can be points of crack initiation
 - Reduce fatigue life
 - Rather than improving it

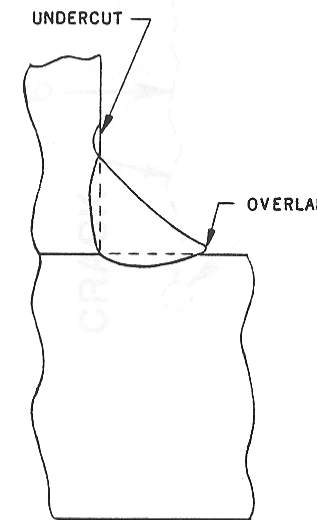

UNACCEPTABLE
FILLET WELD PROFILES

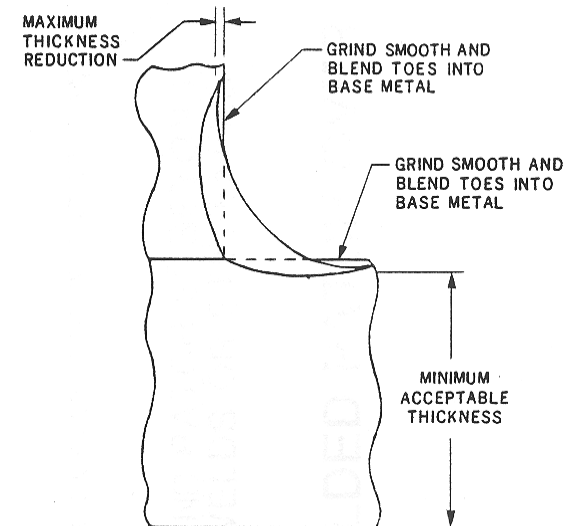

ACCEPTABLE
FILLET WELD PROFILES

Grinding out the Crack and Welding

- Cracks do not usually follow a straight line in aluminum
 - Important to inspect both sides of a crack
 - Determine its path and if it has propagated in different directions
- If crack has crossed a stiffener repair as described for doubler
- Crack should be ground out for its entire length in preparation for welding
- Surface should be thoroughly cleaned with a solvent prior to welding
 - Remove any traces of dye penetrant, oil, grease, oxide film, and imbedded particles of any kind
- Rewelding should begin at the hole
 - Then progress towards the center of the crack
- If crack has propagated in two or more directions
 - Each crack tip should be safe-ended before rewelding
- All repair welds progressed towards the center of the crack
 - Use back-stepping for larger cracks
- Last weld should be thoroughly fused with the first and the crater filled
- Weld should be made from both sides
 - Back chip or grind back side prior to welding
 - Surface should be carefully inspected after back chipping or grinding
- Dye penetrant should not be used for this purpose as it can contaminate the joint

Grinding out the Crack and Welding

- If a two-sided weld cannot be made
 - Permanent or removable backing strip should be used for all butt welds
 - Temporarily hold the backing strip
 - Short-circuit a weld wire to strip one or more locations
 - Will permit strip to be inserted through the opening
 - Use tack welds to hold strip in place prior to final welding

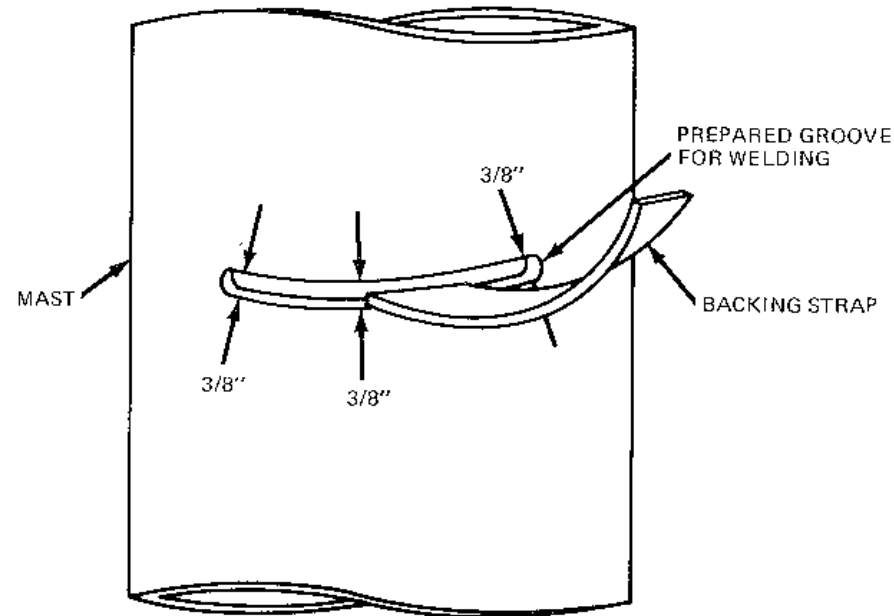

Repair Welds (Cont.)

- Quality of repair weld should be as good as or better than original construction welds
 - Use radiographic inspection
 - Ensure there are no imbedded defects in welds
- Weld surface should be ground flush to maximize fatigue life
- If not possible to radiograph weld
 - Weld bead should not be ground off
 - This may be contributing to the strength of a defective weld
- Use contouring
 - Grinding should be perpendicular to direction of weld
 - Not parallel to it

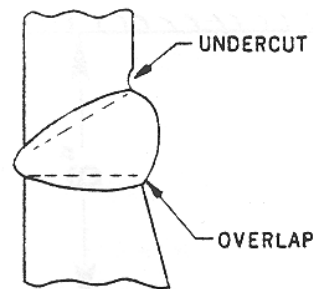

UNACCEPTABLE GROOVE WELD
PROFILES IN BUTT JOINTS

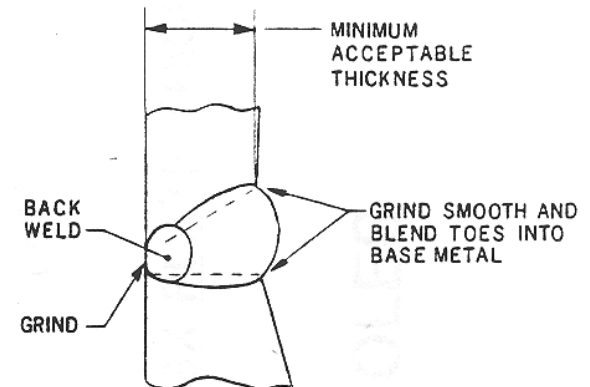

ACCEPTABLE GROOVE WELD
PROFILES IN BUTT JOINTS

Fatigue Data on Contoured Welds

- S-N curves of Eurocode 9
 - Butt weld made from both sides has fatigue classification of 35, 3.4
 - Flush ground butt weld has classification of 45, 7.0
 - For less than 5×10^5 cycles the weld with reinforcement has greater fatigue life
 - At higher cycles flush ground weld is superior
- Naval Surface Warfare Center, Carderock Division (Hay et al., 1995)
 - As-welded butt welds would have classification of 34, 2.64
 - Flush ground butt welds classification of 127, 5.45
- Data provides confidence in the value of grinding welds flush to improve fatigue life
 - Assuming weld first inspected using radiographic inspection

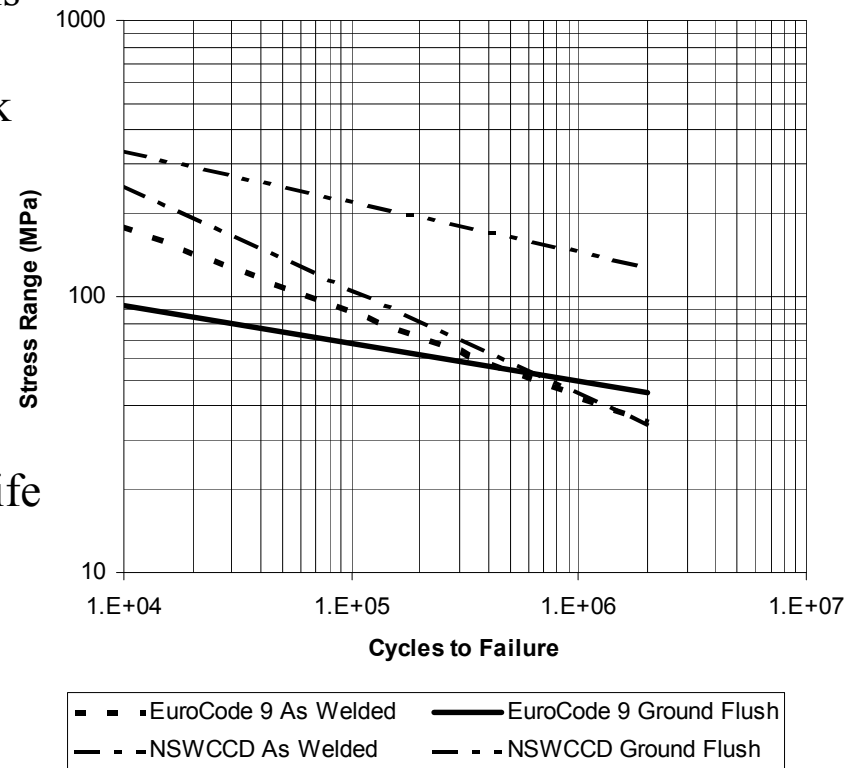

Repair Welds (Cont.)

- Cracks should never be repaired by simply welding over the crack without the preparation mentioned above
 - Such repairs will quickly reinitiate
 - Crack at a faster rate than if no repairs had been attempted

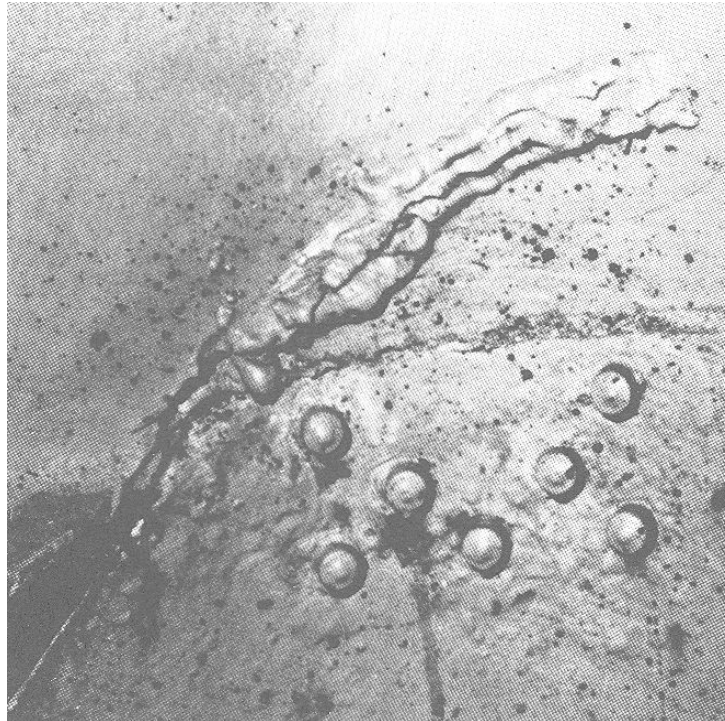

Recracking of one-sided repair weld where the original crack was not removed (Dye and Dawson, 1974).

Repairs of Overstressed or Improperly Designed Details

- Many structural details that are acceptable in steel are unacceptable in aluminum structure
- A structural detail may have to be completely redesigned and large sections of the structure replaced in order to solve a persistent cracking problem
 - In other cases, the situation can be improved by adding brackets, radiused transition plates, or insert plates.
- Ship Structure Committee Report “Improved Ship Hull Structural Details Relative to Fatigue” (Stambaugh et al., 1994)
 - Means of improving the fatigue life of structural details (steel ships)
 - Principles involved for reducing stress concentration factors at structural details are equally applicable to aluminum structural details
 - Example given in Table 12-1 for the intersection of two members
 - Six different configurations of the same detail have stress concentration factors ranging from 3.3 to 2.0
 - Reduction of the stress concentration factor by this amount can extend the life of an aluminum detail by about five times
- Further examples are given in Stambaugh et al. of changes in details to improve fatigue life

Table 12-1: Improvement in Fatigue Life of Structural Detail by Adding Brackets

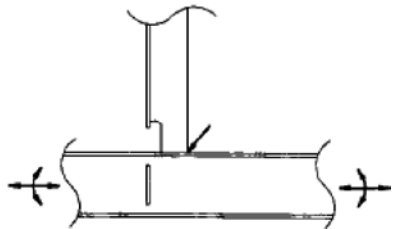
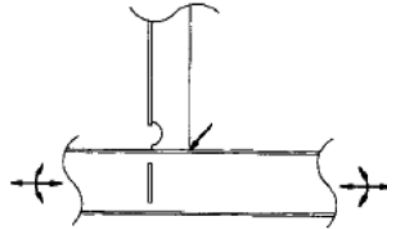
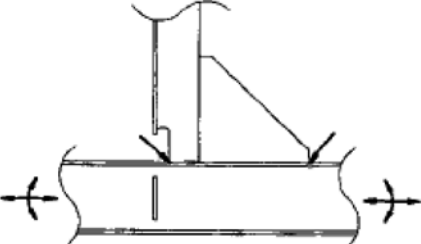
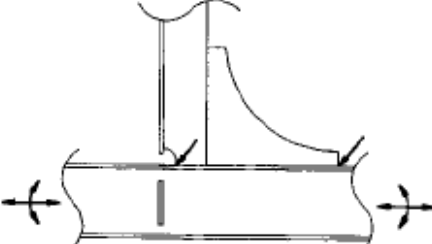
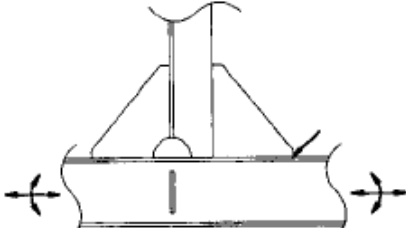
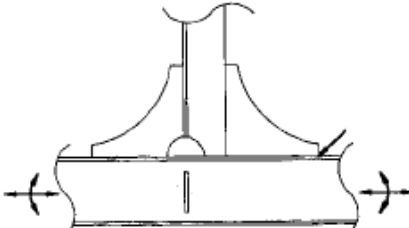
Detail	Stress Concentration Factor	Detail	Stress Concentration Factor
	3.3		2.8
	2.7		2.3
	2.7		2.0

Improperly Designed Details (Cont.)

- Vessels in the 30 to 60-meter size range
- Fatigue cracking from poor structural details often a problem
 - Must appreciate effect of increased longitudinal hull girder bending moments on fatigue
 - Structural detailing and fabrication practices acceptable for smaller craft
 - Will not succeed in the larger vessels
 - Unless scantlings are sufficient to reduce stresses significantly
- Area of concern is at the corners of openings, such as hatch openings
 - Do not use doubler plates to repair cracks in such areas of high stress concentration
 - Use thicker insert plates in corners
 - Insert plate should be at least 3 mm (0.125 in) thicker than original plate
 - If insert is thicker than that
 - The edges should be chamfered at a slope of at least 4 to 1
 - Radius of corner should preferably be equal to one-fourth the width of the opening
 - No less than one-eighth the width
 - Length of insert should be at least 300 mm (12 in) greater than the radius
 - Corners of insert plates should have a radius of at least 75 mm (3 in)
 - Or twice the thickness of the plate, whichever is greater

Reinforcement of a hatch opening

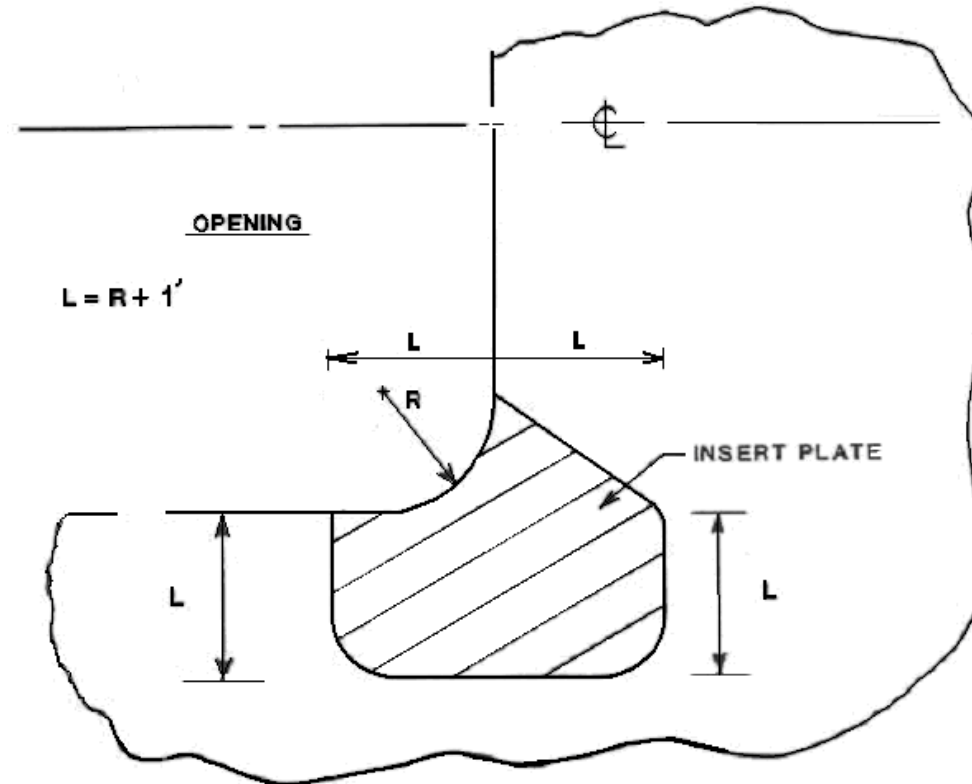

Repairs for Corrosion or Stress Corrosion

- Where seawater is permitted to collect and then evaporate
 - High concentrations of salt will accumulate
 - May eventually corrode through the aluminum structure
 - There will always be minute gaps in the coating
- Marine alloys are tested for exfoliation and intergranular corrosion
 - There are instances where the wrong material is used and corrosion results

Exfoliation

- Both exfoliation and intergranular corrosion are caused by the magnesium migrating to the grain boundaries
 - Generally occurs only in 5xxx-series alloys with 3.0 percent or more magnesium content.
- Exfoliation occurs at the exposed edges of plate
 - Characterized a leafy or flaky appearance

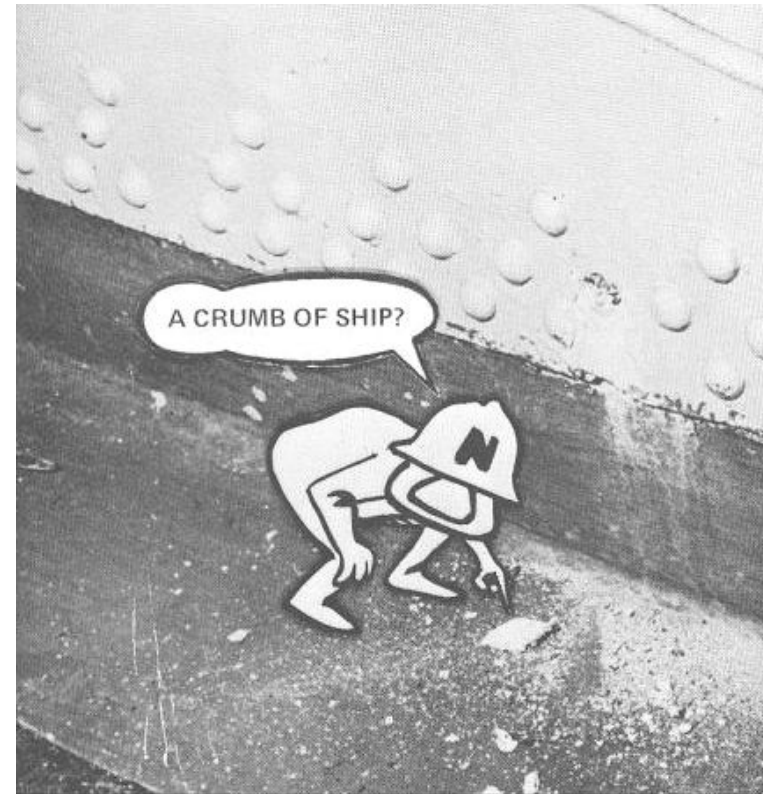
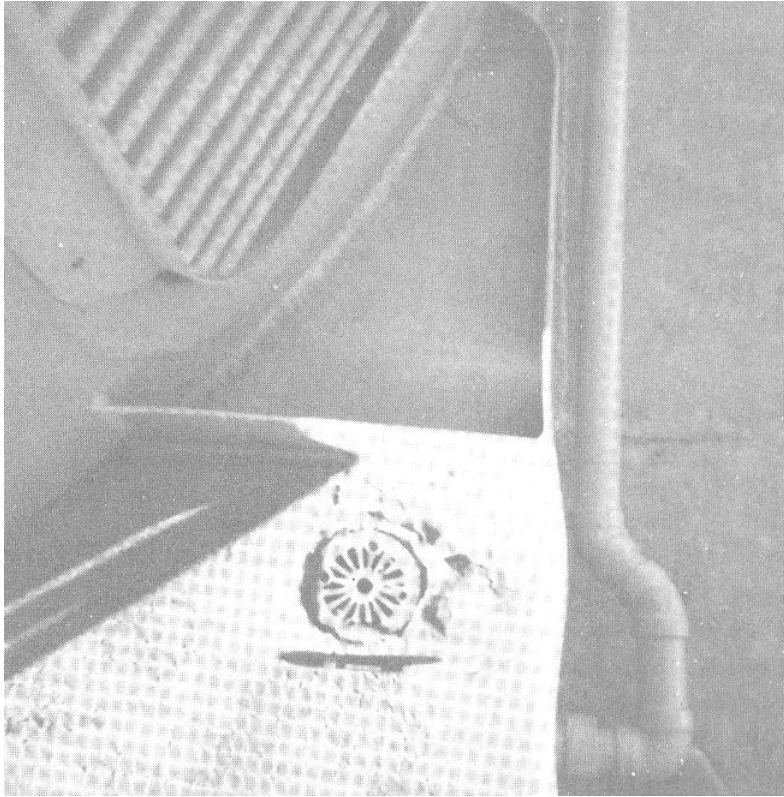

Exfoliation (Cont.)

- When exfoliation is extensive
 - Unsound area of the plate should be replaced
 - Preferably with plate procured to ASTM Specification B 928
 - 5xxx-series alloys produced in H116 and H321 tempers in accordance with that specification are resistant to exfoliation and stress corrosion cracking
 - If that is not possible
 - Free edges of replacement plate should be clad welded to seal the exfoliation-prone edges
 - No special precautions are necessary when welding new plate to exfoliated plate
 - Except to be certain that all areas of corrosion on the existing plate have been removed
 - Weld to solid metal
- If extent of exfoliation is not extensive
 - Plate should be ground back to solid metal
 - Free edges seal welded at least 150 mm (6 in) on each side of the damaged edge
- Once exfoliation has been detected
 - All free edges should be seal welded as a precaution against further exfoliation
- Exfoliation-prone plate can only be detected by removing samples and having them metallurgically using microphotographs.

Intergranular Corrosion

- Recent example of extensive intergranular corrosion
 - Number of vessels were constructed of 5083-H321
 - Prior to the development of ASTM B 928 in 2004



Intergranular Corrosion (Cont.)

- Only remedy is complete replacement of all of the corroded plate
 - Samples should be cut from plate that has not yet shown signs of corrosion
 - Test plate
 - For intergranular corrosion susceptibility in accordance with ASTM G67
 - For exfoliation susceptibility in accordance with ASTM G66.
- 5xxx-series aluminum alloys with magnesium contents greater than 3 percent can become susceptible to stress corrosion cracking if exposed to temperatures greater than 67 °C (150 °F) for extended periods
 - Use alloy 5454 for elevated temperature applications
 - Uptake spaces and stacks
 - Topside structures exposed to solar heat, such as decks
 - Prolonged exposure of exposed topside structure to sunlight, especially in a hot climate, can lead to sensitization of the aluminum to stress corrosion cracking because the deck temperature can easily exceed 67 °C in such circumstances
- Stress corrosion cracking sometimes difficult to distinguish from cracking resulting from other causes, such as high stress

Stress-Corrosion Cracking

- This example demonstrates one characteristic of stress-corrosion cracking
 - o Cracking in the heat-affected zone of the weld
 - o Rather than in the toe of the weld or in the weld itself

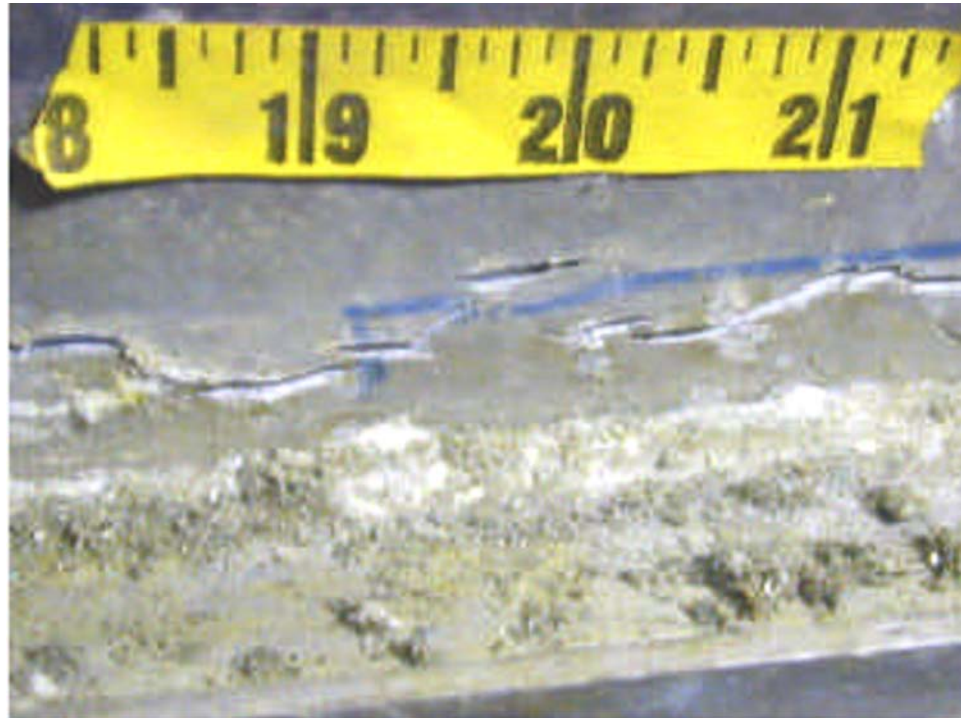

**Stress corrosion cracking and pitting on shell plating
(Bushfield et al., 2003)**

Sensitization and Stress-Corrosion Cracking

- Repair welding the cracks is not effective
 - Plate beyond heat-affected zone is very likely to be as sensitized as area that cracked
- Replacement of the plate is necessary in this case
 - Samples can be removed for metallurgical examination prior to replacement
- ASTM B 928 specifications do not provide resistance to stress corrosion cracking if plate exposed to service at elevated temperatures
- If stress levels do not permit the lower strength 5454-H32 or H34 plate to be substituted
 - Protect replacement plate from higher temperatures
 - Provide insulation or protection from the sun when operating in hot climates.

Summary of Maintenance and Repair

- Aluminum has the potential for excellent corrosion resistance
 - Rapid corrosion can occur from
 - Poor preservation methods
 - Improper alloys
 - Bimetallic coupling
- Rapid crack propagation rates
 - Make aluminum susceptible to fatigue cracking
 - Improperly designed aluminum vessel
 - Can become a maintenance headache
- Redesign of areas prone to fatigue cracking is necessary to promote the safe life of the vessel.

Chapter 13

Mitigating Slam Loads

- Detection of slamming pressures in the bow is difficult
 - Pressures great enough to cause structural damage are not always detected
 - Problem even in large bulk carriers
 - Smaller craft operators generally feel the impact of slam loads
 - Often cannot correlate feeling in the back of their teeth
 - To magnitude of loading on the structure or the structural response
 - Methods of limiting of mitigating the effects of slam loads are needed.

Structural Design

- Plastic deformation of the structure provides capacity to react to an overload situation
Aluminum structures haven't same capacity as steel structures
 - Depending on the alloy, aluminum can deform from 8 to 14 percent before failure
 - Marine steel alloys can deform 25 percent or more before failure
- Energy absorbed through plastic strain
 - Significantly greater than the energy of elastic strain
 - An effective means of absorbing energy
 - Slam loads are of a short duration
- Energy absorption is important for reaction to slam loads
 - If plastic deformation occurs without structural collapse or fracture
 - Vessel can then safely return to port
 - Decide then whether repairs are needed.

Structural Design

- Principles of design for plastic deformation to occur without structural failure
 - Avoid stress concentrations
 - Structural details should have continuity and be continuously welded
 - Stress can flow smoothly from one member to another
 - Cutouts in webs of members adjacent to shell areas subjected to slam loads
 - Should have collar plates fitted to continuously support plating
 - Proportioning of members
 - Stiffeners and frames should be symmetric tee sections
 - Webs and flanges proportioned to not buckle at yield stress
 - Permit overloads to be absorbed by plastic deformation
 - Plating should be continuously welded at stiffeners and frames.
- Provisions for plastic deformation not an explicit part of design criteria
 - Design is for elastic response to specified loads
 - Provision for plasticity provides an implicit increase in load capability
 - Will accommodate overloads that can come from slam loading
- Many sources of overloads in high-speed craft
 - Surface effect craft falling off of cushion

Preferred Course and Speed

- Limit ship motions and slam loads in a seaway
 - Make operator aware of effects of heading and speed on motions and loads
 - Provide polar plot of response vs. heading relative to wave

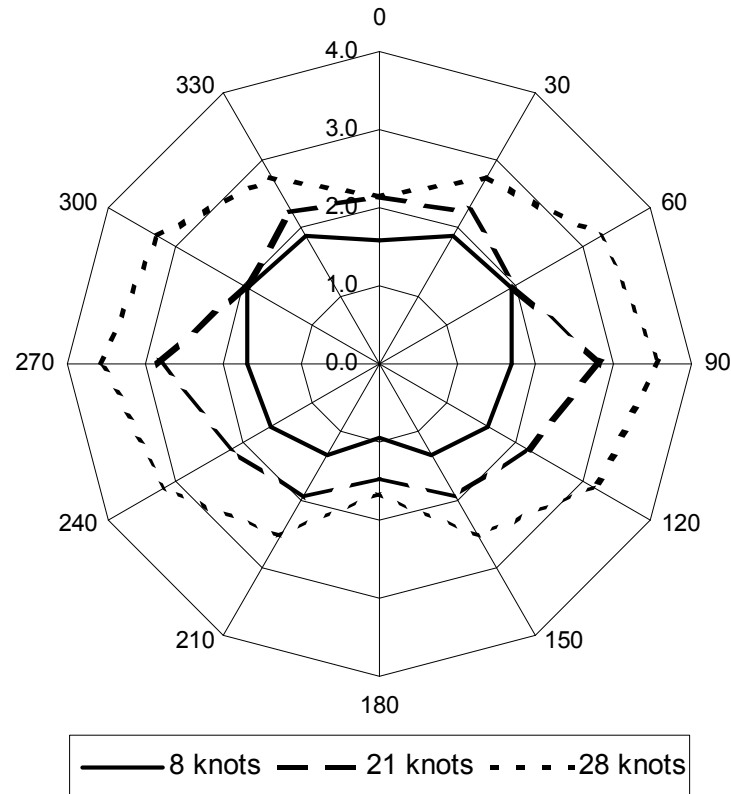

Polar plot of pitch angle for a patrol vessel in Sea State 3 (Chiu et al., 2005)

Weather Routing

- Many aluminum high-speed vessels
 - Designed for limited service and operating on a short fixed route
 - Answer to load reduction often avoidance or delay of service
- If predicted sea states on the vessel's route exceed design maxima
 - Vessel must remain in port until the weather abates.
- For vessels operating on a longer route
 - Take alternative courses to avoid severe weather patterns
 - Many weather routing services are available
 - To use effectively, must have knowledge of response of vessel to different sea states
 - Route can be selected that avoids sea conditions that will cause damage
 - Deviate less from the route that results in shortest transit
 - Route with greater distance traveled may result in shorter transit time
 - Speed will not have to be reduced much, if at all

Hull Instrumentation

- Accelerations that craft experience when operating at high speeds
 - Classification societies determine slam and other loads using accelerations as a factor
- Basic relationship between slam loads and accelerations
 - First established by Heller and Jasper (1961)
 - Developed further by Allen and Jones (1978)
- All high-speed craft have design values of acceleration incorporated into the process for determining scantlings
 - Whether determined by empirical formulae or by numerical analysis or model tests
 - For craft in limited service conditions
 - Design values represent the maximum allowable value
 - For craft with unlimited service conditions
 - Design acceleration probability of exceedance of 10^{-8}
- To avoid damage from slamming
 - Avoid exceeding the design acceleration value
- Installed instrumentation will provide information on accelerations being experienced

Hull Instrumentation (Cont)

- Many classification societies either require or else provide special classification for vessels having hull-monitoring systems

- o ABS Guide for Building and Classing High Speed Naval Craft (HSNC)

- Three notations for installations
- Made in accordance with the ABS Guide for Hull Condition Monitoring Systems (ABS, 2003A)

HM1: This notation and the appropriate description of “Green Seas Warning” are assigned to a vessel having hull condition monitoring systems for the purpose of motion monitoring.

HM2: This notation and the appropriate description of “Hull Girder Stress” will be assigned to a vessel having a stress monitoring system. The system may include local stress and fatigue monitoring system.

HM3: This notation and the appropriate description of “Full VDM” will be assigned to a vessel having a Voyage Data Monitoring system.

Hull Instrumentation (Cont)

- For large high speed craft the vertical acceleration values might not be a reliable indicator of slam loads for large high-speed craft (ISSC V2, 2000)
 - Localized slam loads only minor part of total forces and accelerations
 - Slamming forces have little effect on the craft's motion
- Relative velocities and angles between the structural part and the water surface at the point of impact are more important parameters
 - Either pressure gauges mounted at strategic points
 - Or strain gauges on critical structure
 - More reliable indicator of slamming
- Pressure gauges may not be accurate indicators of the possibility of damage from slam pressures
 - Peak pressures tend to be localized
- Strain gauges placed on a plate panel or stiffener indicate the averaged effect of the slam loads
 - Indicate if structural damage is being done
 - If a plate panel is significantly dished in from a slam load
 - Subsequent slams will indicate lesser stress
 - Greater membrane stress on a deformed plate pane
 - Gauges should be placed on stiffeners
 - More linear in their behavior even if slightly deformed plastically

Tanker Hull Instrumentation

- Tanker hull monitoring systems used for some time
 - o Review of tanker systems Slaughter et al. (1997)
 - o 200 HRMS installed at that time, with at least 11 active manufacturers
 - o Most systems for hull girder response with deck-mounted strain gauges
 - o Additional sensors and capabilities, including position (GPS), motions (accelerometers, gyros), hull hydrostatic pressure (external and in-tank), weather and motion prediction, and linkage to other ship instruments such as speed, power, and cargo loading.
 - o Typical system costs at that time were about \$50,000 for the equipment and an additional \$50,000 for installation.
- Four different types of instrumentation used for measuring strain:
 - o Short baseline, foil gauges
 - o Long baseline, typically 2 meters long with linear potentiometer, linear variable differential transformer, or linear displacement transducer
 - o Derived systems in which the hull girder bending moment and stress are estimated using motion sensors.
 - o Developmental systems, including fiber optics, acoustic, and laser/radar ranging, all of which were considered to be proven technology but not yet commercial state of the art.

Tanker Hull Instrumentation (Cont.)

- Pressure gauges most frequently used to measure slamming pressures
 - Underwater gauges should be replaceable without entering drydock
 - Should not be overly damped if slam pressure accuracy is desired
- Failure of pressure sensors were the most frequent equipment failure in hull monitoring systems
- Signals from gauges to the central processing unit were either hard-wired, using grounded cable, or by radio link
- Preprocessors generally required near the sensors in hard-wired installations to reduce transmission loss
- Radio systems required transmitters near the sensors
- Several manufacturers were experimenting with fiber optic systems
 - Not in commercial operation in 1997

Tanker Hull Instrumentation (Cont.)

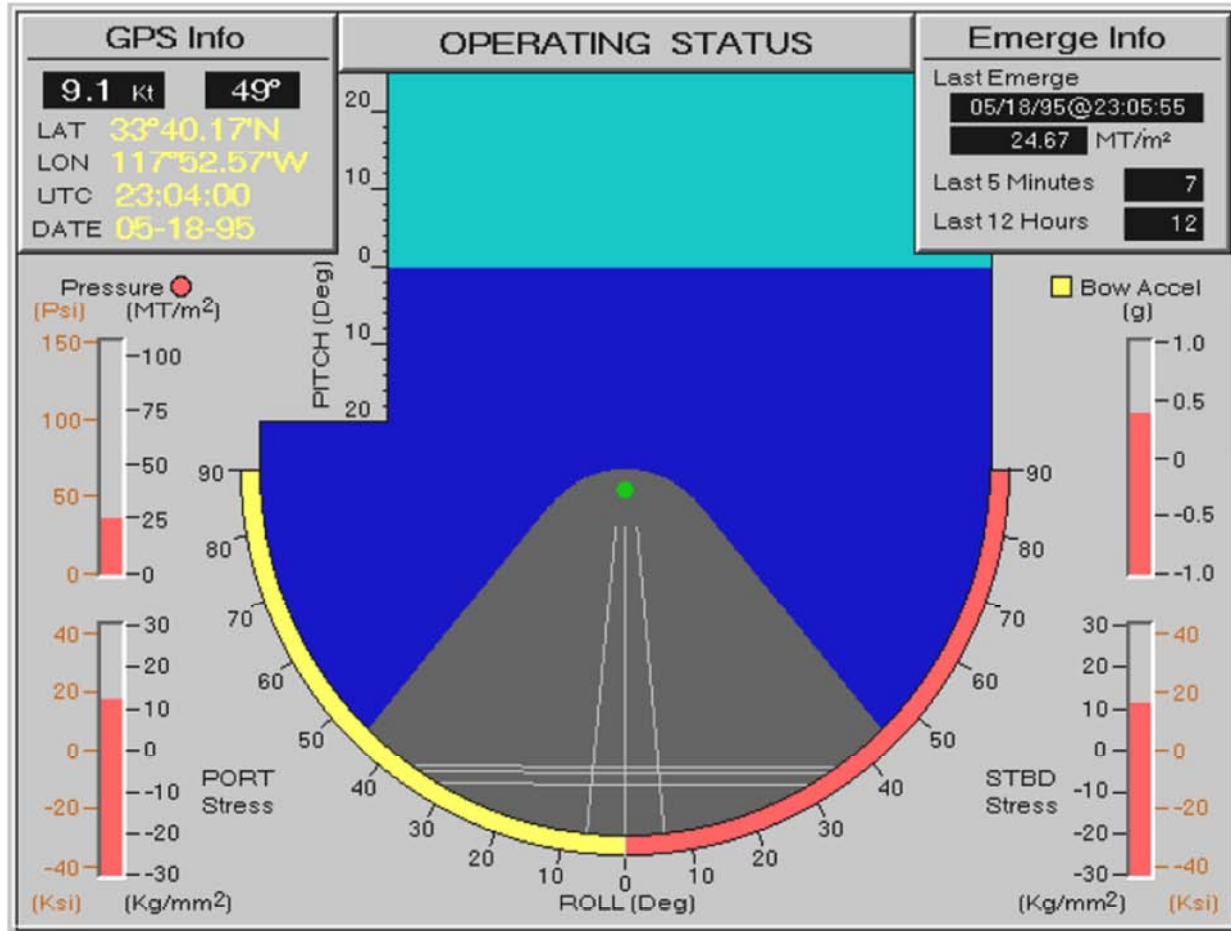

Example of the bridge display from a hull monitoring system for a tanker (Slaughter et al., 1997)

Hull Instrumentation (Cont)

- Recent review of hull monitoring systems (Steen and Kauczynski, 2002)
 - Including various systems for measuring ship motions and for providing operational guidance to the ship's operators
- Apply fiber optic sensors to measure the local stress (Bragg grids)
- Systems using ordinary ship radar for measurements of wave height
 - Also measure directional wave spectrum
 - Determining distribution of wave energy
 - Function of wave direction and frequency
 - The systems analyze sea clutter
 - Usually filtered out of the display on the radar screen
 - Wave height and periods determined from modulation of radar signals from water surface roughness
 - Systems require radar having the X-band
 - Special requirements for radar rotation speed and frequencies
 - Usually more convenient to add dedicated radar for this system

Hull Instrumentation (Cont)

- Measure ship motion with several high-precision accelerometers and inclinometers or gyroscopes
 - In combination with on-line computations performed by integrated circuitry
 - System measures acceleration and motion in six degrees of freedom
 - Motion or acceleration on any point on the ship then found
 - Not necessary to have accelerometers placed around the ship
- Measurements of the ship position and speed with global positioning satellites (GPS)
 - GPS - tolerance of the vessel location in a range of 1-20 m
 - DGPS - tolerance of the vessel location in a range of 1 m
 - CDGPS - tolerance of the vessel location in a range of 1 cm
 - GPS receivers allow determination of the location and speed of ships in surge, sway and heave with a quite high accuracy
 - Installation of two or more antennas on the hull, separated at a minimum distance of 3–5 m, it is also possible to determine the ship rotations in roll, pitch and yaw.

Hull Instrumentation (Cont)

- Hull monitoring system integrated with ship remote monitoring system (Koshio et al., 2005)
- Japanese Super Liner Ogasawara, a 140-meter, 39-knot surface effects ship
 - Data communication & management system
 - Navigation support system
- Four remote monitoring systems, consisting of systems for the propulsion and lift engines, seals, and a remote monitoring system for hull structure
- Hull monitoring system has about 60 sensors
 - Accelerations, pressures and strains
 - Fiber optic sensors monitor hull girder longitudinal bending strains
 - Data analyzed statistically on board
 - Along with wave data, ship motions and accelerations
 - Results are displayed on bridge screen
 - If data exceeds designated values
 - System alerts crew
 - Sends alarm signal with data to central station via satellite communication system
 - Cumulative fatigue damage of important members of the ship structure is calculated from monitored strains for use in structural maintenance

Hull Instrumentation (Cont)

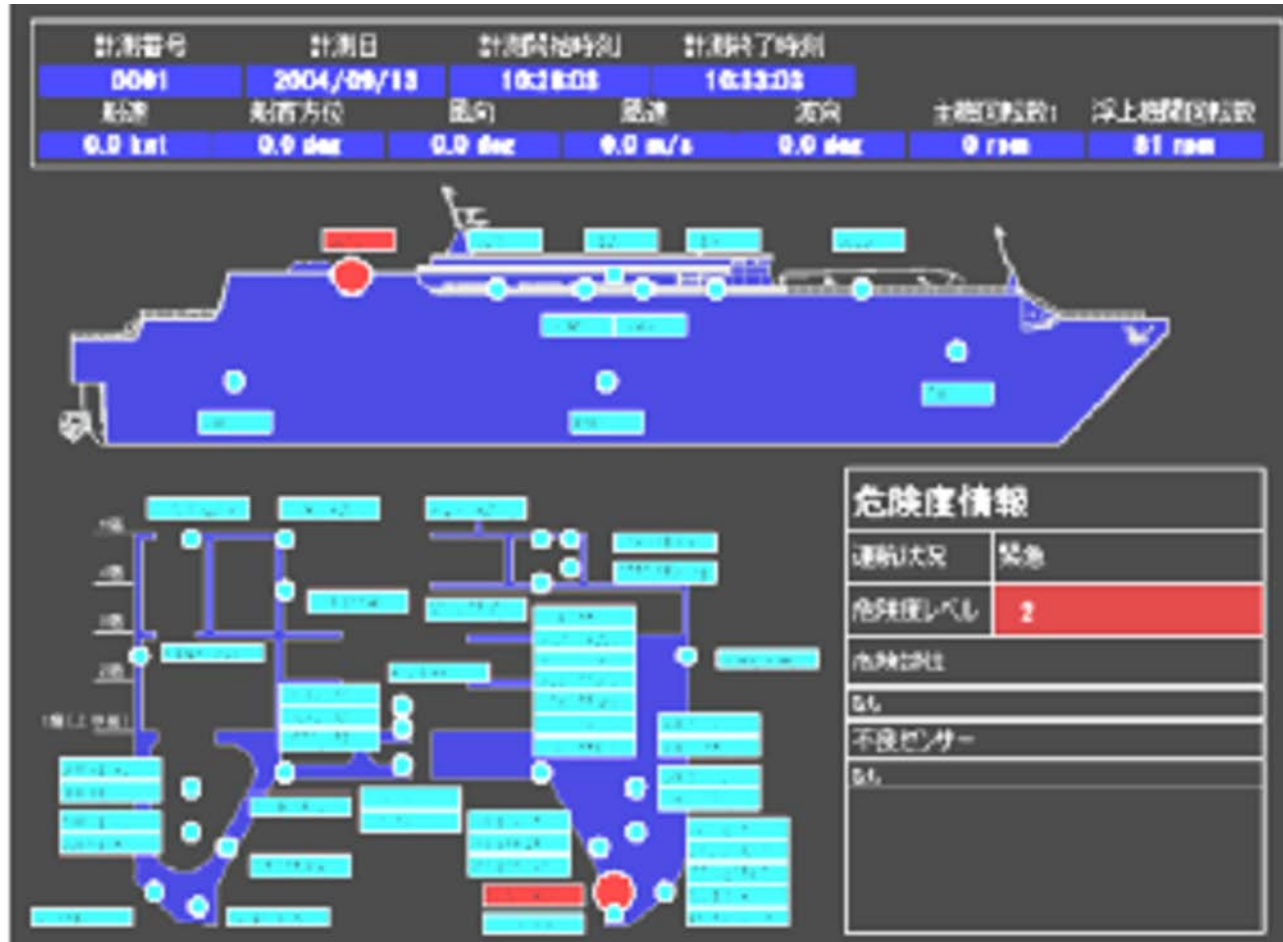

Display of monitoring system of super liner Ogasawara (Koshio et al., 2005)

Hull Instrumentation (Cont)

- Off-line” system (Petinov, 2006)
 - Alternative, less expensive system
- Operates with non-instrumented input
 - Visually estimated sea state, ship speed, and heading angle
- Software based on application of the Wiener-Khinchinne theorem
- Using:
 - Wave frequency spectrum
 - Hull response frequency spectrum
 - Response function variance
 - Characteristic response parameters (ship motion parameters, stress in a particular location, etc.)
- Recommended changes of ship speed, heading angle
 - Avoid excessive slams, or excessive damage accumulation
- System provides approximate guidance
 - Does not require gauging, installation, and maintenance
 - May be important for relatively small craft

Summary of Mitigating Slam Loads

- Magnitude of slam loads can be uncertain
 - Structure should be designed to withstand slam overloads
- Information to operators of vessels
 - Effect of changes of course and speed on slam loads
 - Slamming can be reduced if it occurs
- Sea conditions that would possibly produce slam damage should be avoided
 - Routing systems need to have information as to the possibility of slamming occurring in different sea states and at different speeds and headings
- Operator often cannot perceive severity of slam in terms of structural damage
 - Instrumentation systems should be used to make operators aware of current conditions.

Chapter 14

Emerging Technologies

- Friction Stir Welding
 - Solid state joining process developed by The Welding Institute in 1991
 - Process initially investigated by a number of industries
 - Great usage in marine industry for joining lightweight panels
 - Process used for corner sections, T-sections and different lap-joint configurations
 - Most suited for butt welds
 - Solid-state process
 - Metal never reaches melting temperature
 - Shielding gas is not necessary
 - High quality weld can generally be made with fewer weld defects
 - Low residual stresses
 - Absence of solidification cracking, porosity and oxidation

Friction Stir Welding Process

- Cylindrical shoulder tool with a specially designed and profiled probe
 - Made from a hard, wear resistant material relative to the material being welded
- Rotated at a high speed
 - Slowly plunged into abutting edges of parts to be joined.

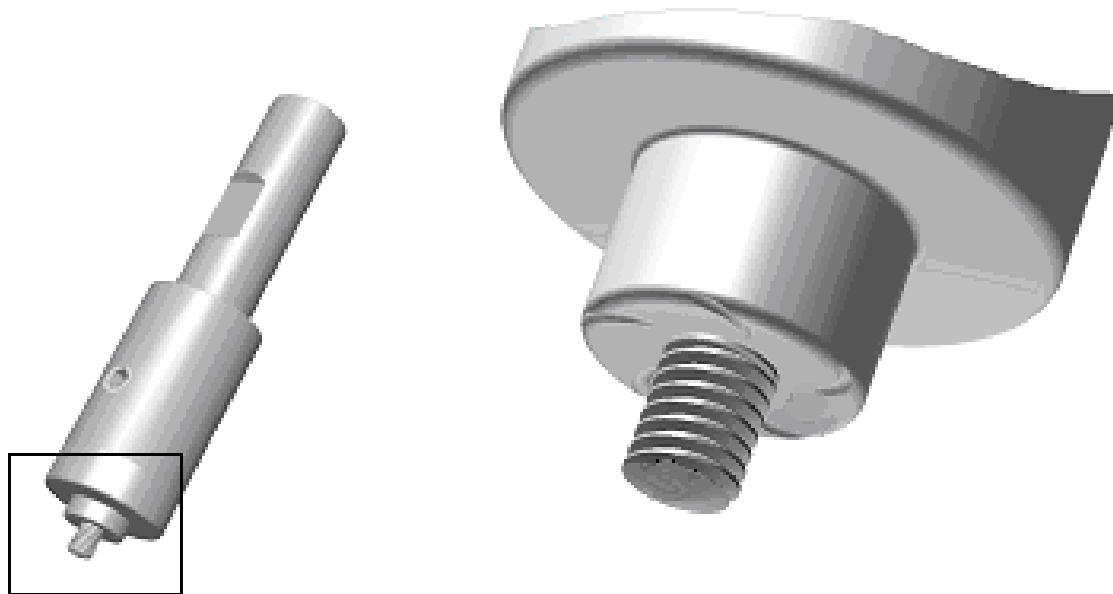

Tip of the friction stir welding tool (TWI)

Friction Stir Welding Process (Cont.)

- Plates to be joined are clamped on a backing plate to resist the vertical, longitudinal and lateral forces, trying to lift and push them apart
- Rotating tip of the friction stir welding tool
 - Produces heating action in material along bond line
 - Produces required thermo-mechanical deformation

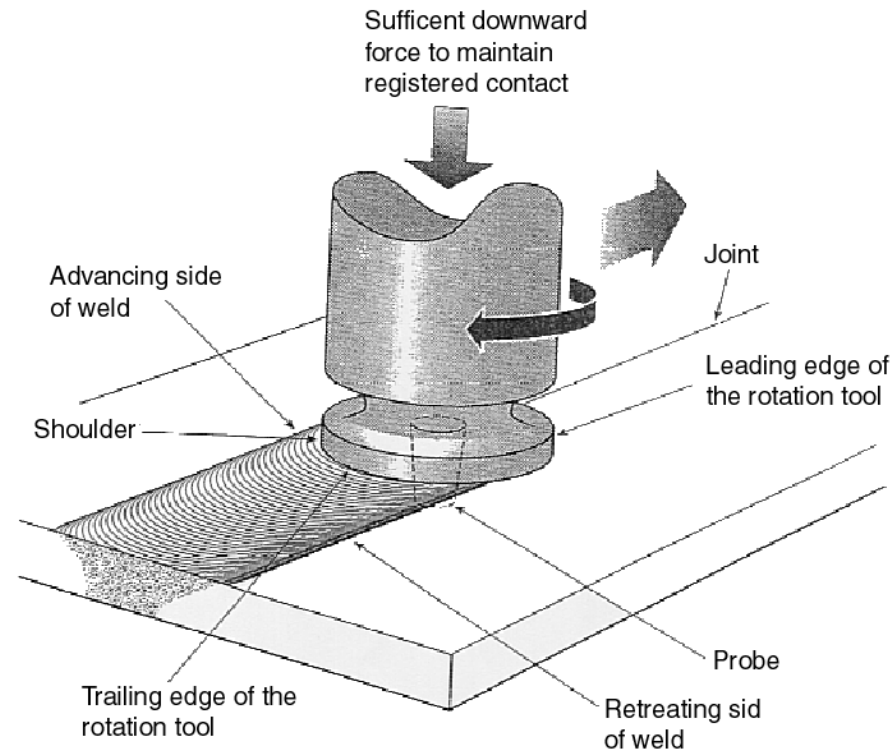

Schematic illustration of friction stir welding (TWT)

Friction Stir Welding Process (Cont.)

- During welding, probe first makes contact as it is plunged into joint region
- Initial plunging friction heats a cylindrical column of metal underneath the probe
 - Material softens without reaching the melting point
 - Allows traversing of the tool along the welding line
- Depth of penetration controlled by length of probe below shoulder of tool
 - Contacting shoulder applies additional frictional heat to weld region
 - Prevents highly plasticized material from being expelled during welding operation
- Once shoulder makes contact
 - Adjacent thermally softened region takes up a frustum shape corresponding to the overall tool geometry
- The design of the rotating tip varies with the thickness and composition of the parts being joined
 - Tip designs are proprietary to organization conducting friction stir welding
- Other variables of the process include rotational speed, speed of advancement, downward force of the tool, and fixturing for holding the parts

Friction Stir Welding Process (Cont.)

- Weld is autogenous, no filler metal is added during the welding process
 - Parts to be joined must have a minimum gap between them
 - As metal reformed as the tool moves on
 - Difference in volume compensated for by reduction in thickness
 - If gap is uneven, thickness of weld will also be uneven
 - Special extrusions with slightly increased thickness at the edges
 - Resulting weld is same thickness as base plate
- Friction stir welds not symmetric about weld centerline due to tool rotation
 - Advancing side — rotational velocity of tool same direction as welding velocity
 - Retreating side — two velocities have opposite direction
 - Slight buildup on the advancing side
 - This burr not always present
 - Generally removed by grinding to maintain a smooth surface

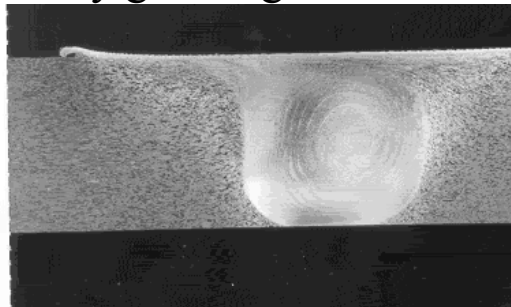

Section through friction stir weld (Advanced Joining Technologies web site)

Friction Stir Welding Process (Cont.)

- Friction stir welds show a characteristic cycloidal pattern of ripples
 - o Produced by final sweep of trailing circumferential edge of shoulder



Facilities for Friction Stir Welding

- Typical facilities for joining extrusions to form a panel
 - Flat table holds the completed portion of the panel in place
 - Sections being joined are clamped
 - Moving friction stir welding head moves over the joint
- Tables up to 15 meters (50 feet) available (Halverson and Hinrichs, 2006)
- For shorter welds, a milling machine can be used

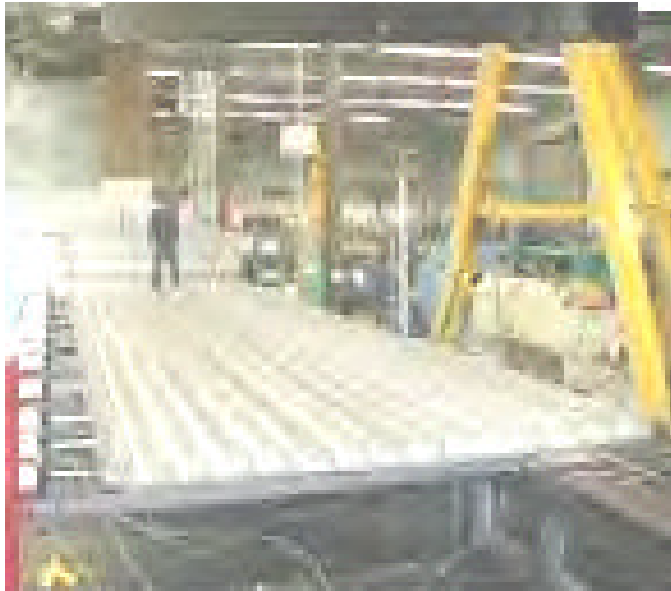

**Friction stir welding panels together
(Advanced Joining Technologies web site and The Welding Institute)**

Facilities for Friction Stir Welding (Cont.)



Mitsui Engineering and Shipbuilding Company (Koshio et al., 2005)

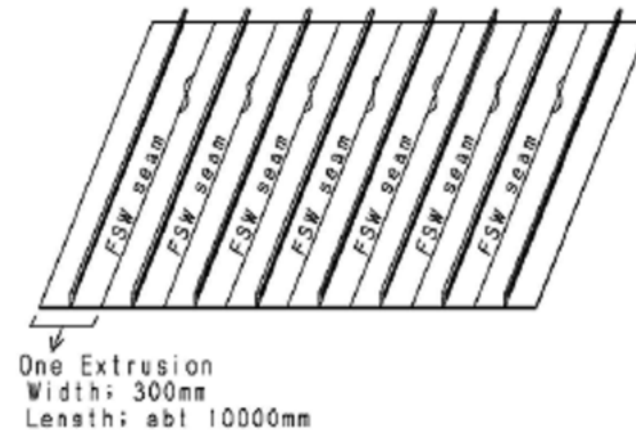
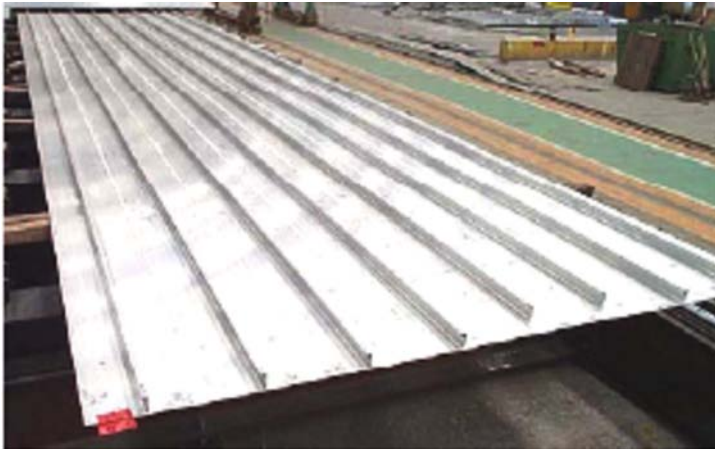

Mitsui Engineering and Shipbuilding Company (Koshio et al., 2005)

Advantages and Disadvantages of Friction Stir Welding

- Advantages
 - Low distortion
 - No shielding gas required
 - No fumes, sparks, or spatter to clean up
 - Consistent weld quality with little inspection required
 - As long as the root gaps in the joints are consistent
 - Can weld dissimilar metals and aluminium alloys that are difficult to fusion weld
 - 2xxx and 7xxx aluminum alloys
 - Join narrow plates to make wide plate
- Disadvantages
 - Special facilities required
 - Work must be brought to facility
 - Process is too complex for shipboard production or repair welds
 - Burr can form
 - Produces a keyhole at the beginning and end of each weld
 - Panels must be trimmed after welding
 - Or defect repaired with a conventional fusion welding processes
 - Unless runoff tabs are welded beforehand
 - Typical welding speed 750mm/min for 5mm 6xxx series aluminum alloy
 - Slower than welding using GMAW.

Standards for Friction Stir Welding

- American Welding Society has developed inspection requirements (Halverson and Hinrichs, 2006)
 - Each welding procedure specification must be documented in accordance with the latest AWS ANSI/AWS D1.2-XX Structural Welding code — Aluminum
 - Procedure qualification records for each welding procedure must be recorded as well
 - American Bureau of Shipping is one of the certifying agencies
 - Typical production quality sampling plan might call for radiographic inspection and dye penetrant inspection of the weld root
- Recent ship design reported by Halverson and Hinrichs
 - Initial sampling done on test specimen removed from end of weld on every third panel
 - As the process became stable
 - Frequency was reduced to every fifth panel welded
 - Test specimen — joint tensile and root bend test
 - Specimen containing friction stir welding tool hole at end of weld was discarded

Materials and Thickness

- All aluminum alloys can be joined by friction stir welding
 - Including otherwise unweldable alloys
 - 2xxx, 5xxx, 6xxx, 7xxx, and 8xxx-series
- Single pass butt joints
 - Thicknesses from 1.2 to 50 mm
 - Edge preparation not needed
 - Optimum welding in thickness range from 1.6 to 10 mm
- Lap welds for thicknesses of 1.2 to 6.4 mm
- Thicknesses of up to 100 mm in 6082 alloy can be welded using two passes.
- Friction stir welding used to join 2-mm 5083 plate to mild steel of the same thickness
 - May be able to replace the bimetallic joint currently used between steel and aluminum
 - The joint will present a smooth surface
 - Sightlier
 - Easier to maintain
 - Present a lower radar cross section

Joint Design

A number of different joint geometries, such as those shown in Figure 14-1, are possible with friction stir welding (Halverson and Hinrichs, 2006).

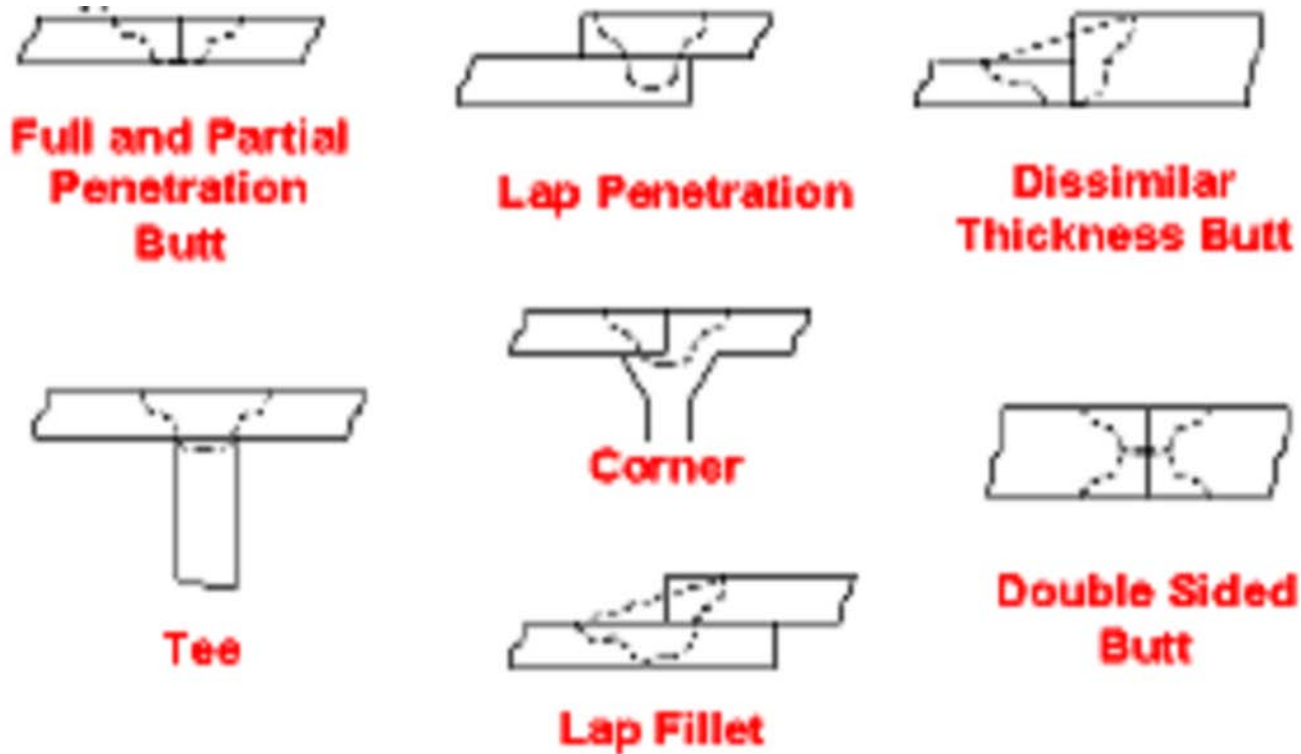

Figure 14-1 Friction stir weld joint geometries (Halverson and Hinrichs, 2006).

Strength of Friction Stir Welded Joints

Table 14-1 Typical Mechanical Properties of Friction Stir Welded Aluminum Specimens

Material	0.2% Proof strength Mpa	Tensile strength Mpa	Elongation %	Welding factor UTS _{FSW} /UTS _{PARENT}
5083-0 Parent	148	298	23,5	N/A
5083-0 FSWed	141	298	23	(1.00)
5083-H321 Parent	249	336	16,5	N/A
5083-H321FSWed	153	305	22,5	0.91
6082-T6 Parent	286	301	10,4	N/A
6082-T6 FSWed	160	254	4,85	0.83
6082-T6 FSWed and aged	274	300	6,4	(1.00)
6082-T4 Parent	149	260	22,9	N/A
6082-T4 FSWed	138	244	18,8	(0.93)
6082-T4 FSWed and aged	285	310	9,9	(1.19)
7108-T79 Parent	295	370	14	N/A
7108-T79 FSWed	210	320	12	(0.86)
7108-T79 FSWed naturally aged	245	350	11	(0.95)

Fatigue Strength

- Fatigue tests by Dawes and Thomas (1995)
 - 6 mm thick 5083-O and 2014-T6
 - Fatigue performance alloy 5083-O comparable to parent material
 - Tested using a stress ratio of $R=0.1$.
- Available fatigue data shows performance of friction stir welds is comparable with that of fusion welds
 - Most cases substantially better
- Fatigue strength of alloy 6082 in Figure 14-2
 - Data compared to Eurocode 9 S-N curves for butt welds in aluminum
 - Friction stir welds all exceed the standard

Laser Welding

- Friction stir welding has found a useful niche in the fabrication of lightweight aluminum panels
 - Limited in usefulness for other portions of the structure
 - Equipment involved
- Welding with a high-energy laser
 - Potential for greater flexibility and greater use
- Two types of lasers commonly used in metalworking
 - Solid-state lasers
 - Crystal of yttrium, aluminum, and garnet doped with neodymium (Nd:YAG)
 - Most common solid laser
 - Synthetic ruby and chromium in aluminum oxide
 - Neodymium in glass (Nd:glass)
 - Gas lasers
 - Carbon dioxide
 - Helium
 - Nitrogen

Laser Welding (Cont.)

Solid-state Lasers

- Solid-state lasers operate at wavelengths on the order of 1 micrometer
 - Much shorter than gas lasers
 - Require that operators wear special eyewear to prevent cornea damage
- Nd:YAG lasers can operate in both pulsed and continuous mode
 - Other types are limited to pulsed mode
- All use single crystal shaped rod
 - Approximately 20 mm in diameter
 - 200 mm long
 - Ends are ground flat
 - Rod surrounded by flash tube containing xenon or krypton
- When flashed, the laser emits a pulse of light lasting about two milliseconds
- Typical power output
 - Ruby lasers — 10–20 W
 - Nd:YAG laser — 0.04–600 W

Laser Welding (Cont.)

Solid-state Lasers (Cont.)

- o Fiber optics usually employed to deliver laser beam to weld area
 - Potential for a great deal of flexibility in their use
 - Fiber optic cables up to 100 meters long
 - Brings laser beam to the workpiece
 - Can include shielding gas as well as filler wire
 - Welding of 2024/5052/6061 aluminum requires filler metal of 4047 aluminum
 - Makes hermetic, crack-free welds (Miller, 2005)

Laser Welding (Cont.)

Gas Lasers

- Gas lasers use high-voltage, low-current power sources
 - Provide energy to excite gas mixture used as lasing medium
 - Operate in both continuous and pulsed mode
- Wavelength of the laser beam is 10.6 μm
 - Lens and mirror delivery system is used
 - Result of the higher wavelength
- Power outputs for gas lasers up to 25 kW.

Laser Stir Welding

- Combines the energy of a laser beam with the oscillating motion of the beam to stir the molten pool
- Process developed and patented by Alcoa and Pennsylvania State University

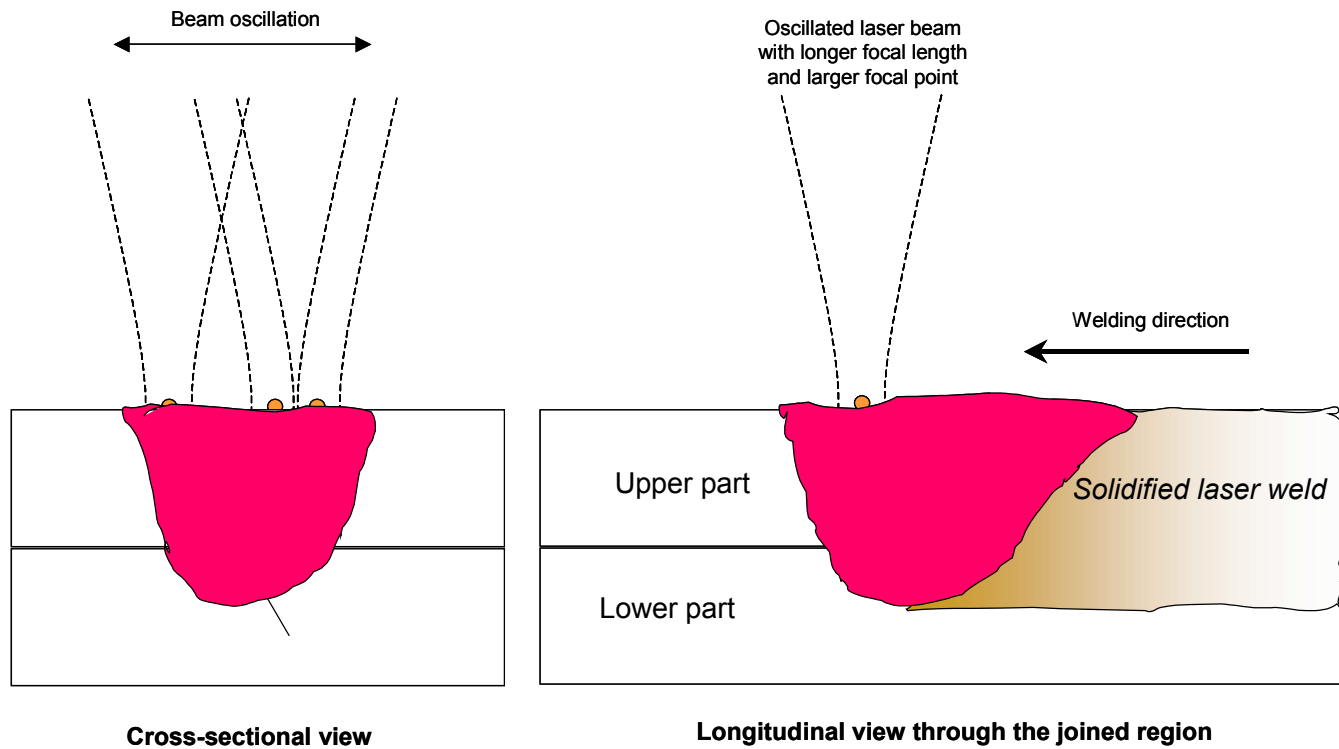

Laser Stir Welding (Cont.)

- Laser stir welding establishes a molten pool and moves the keyhole in it while continuously re-filling the pool with the adjoining molten metal. The welding is accomplished by translating a self-healing keyhole through a molten pool

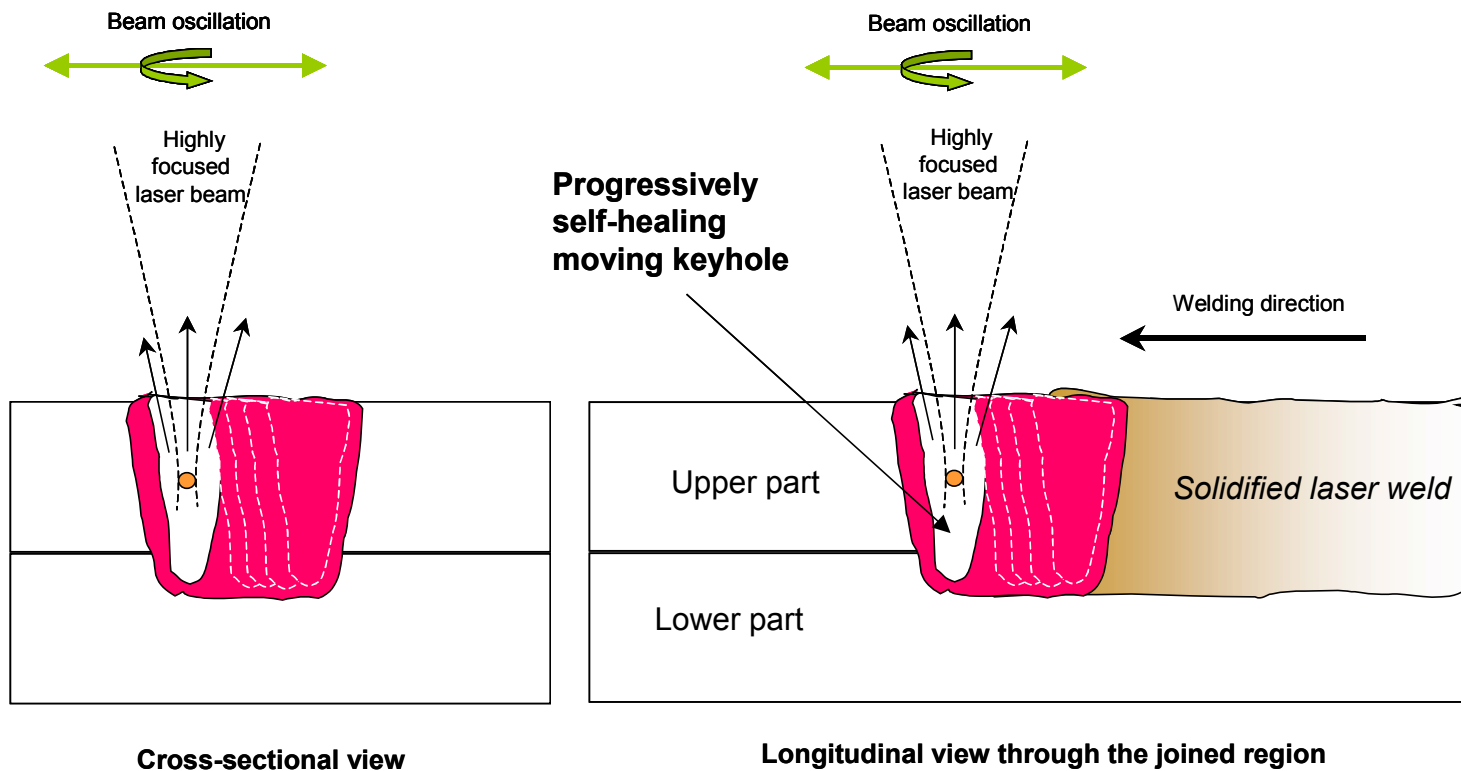

Laser Stir Welding (Cont.)

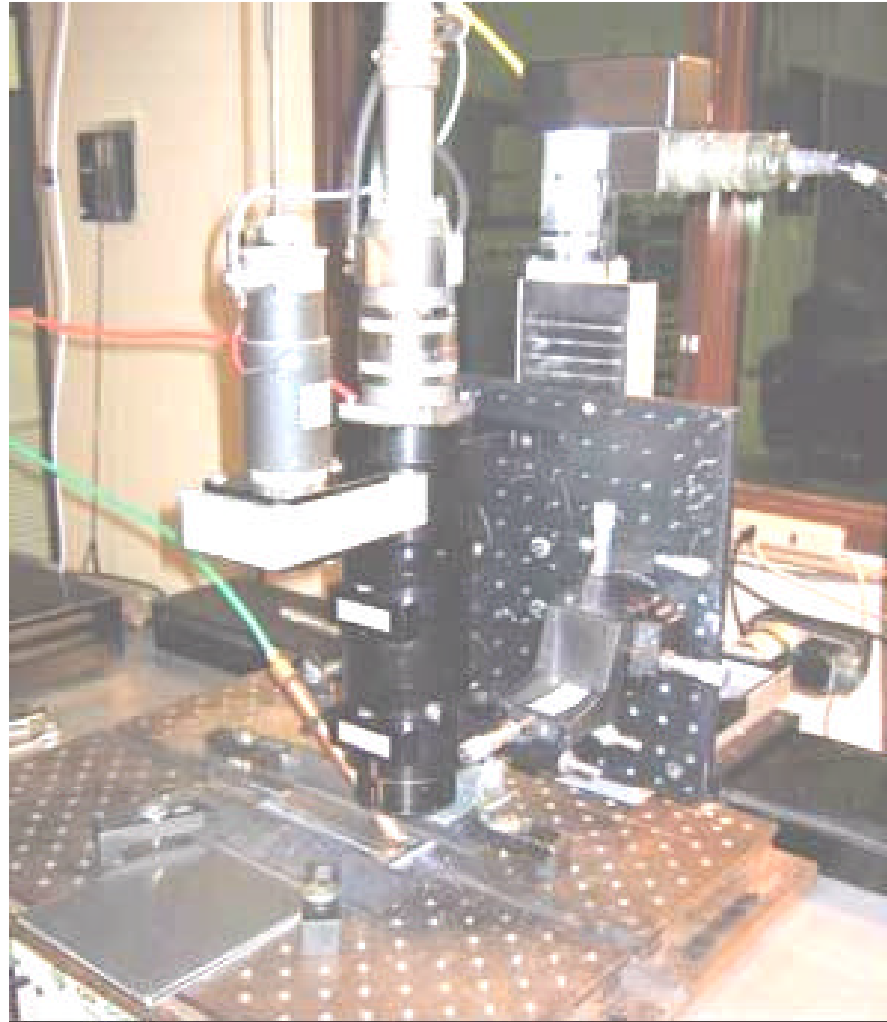

Experimental apparatus for laser stir welding (Martukanitz and Tressler, 2006).

Laser Stir Welding (Cont.)

- Process manipulates the laser beam in a circular pattern
 - Provides a stirring action
 - Results in improved weld soundness for laser beam welding of aluminum alloys
- Initial investigations on 6013-T4 with of 3.0 mm thickness
 - TRUMPF 4.5kW diode-pumped Nd:YAG laser
 - Fiberoptic beam delivery through a 600 μ m diameter fiber

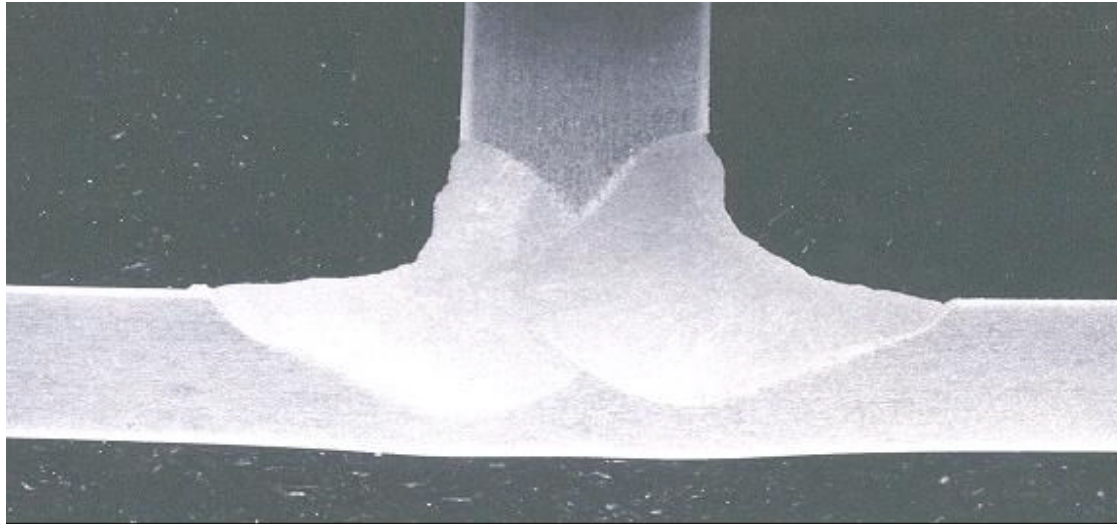

Laser stir fillet weld (Alcoa, Inc.)

Electron Beam Welding

- Fusion welding process
 - Process developed in France in 1957
 - Beam of high-velocity electrons is applied to materials being joined.
 - Workpieces melt
 - If filler metal is used it also melts to form part of the weld
 - Welding often done in a vacuum to prevent dispersion of the electron beam

Heat penetrates deeply

Possible to weld much thicker workpieces

Electron beam is tightly focused

Total heat input much lower than arc welding process

Heat-affected zone is small

Distortion is slight

Work piece cools rapidly.

Electron Beam Welding (Cont.)

- Three primary methods of electron beam welding
- Welding chamber is in a hard vacuum
 - Material as thick as 15 cm (6 in) can be welded
 - Distance between the welding gun and workpiece (the stand-off distance) can be as great as 0.7 m (30 in)
- Welding in a soft vacuum
 - Allows for larger welding chambers
 - Reduces the time and equipment to evacuate chamber
 - Reduces the maximum stand-off distance by half
 - Decreases the maximum material thickness to 5 cm (2 in)
- Nonvacuum or out-of-vacuum electron beam welding
 - Performed at atmospheric pressure
 - Standoff distance diminished to 4 cm (1.5 in)
 - Maximum material thickness is about 5 cm (2 in)
 - Allows for workpieces of any size to be welded

• **Electron Beam Welding (Cont.)**

- The process became widely used beginning in the 1960s
 - Initially for welding small, thin materials
- Development of nonvacuum processes, was used for thick materials
 - Thick aluminum spheres for liquid natural gas carriers in the 1960s.
- Study to use process to form 5xxx series panel with 2-mm thickness
- Shown in Figure 14-3 (Kryzhevich et al., 2005)

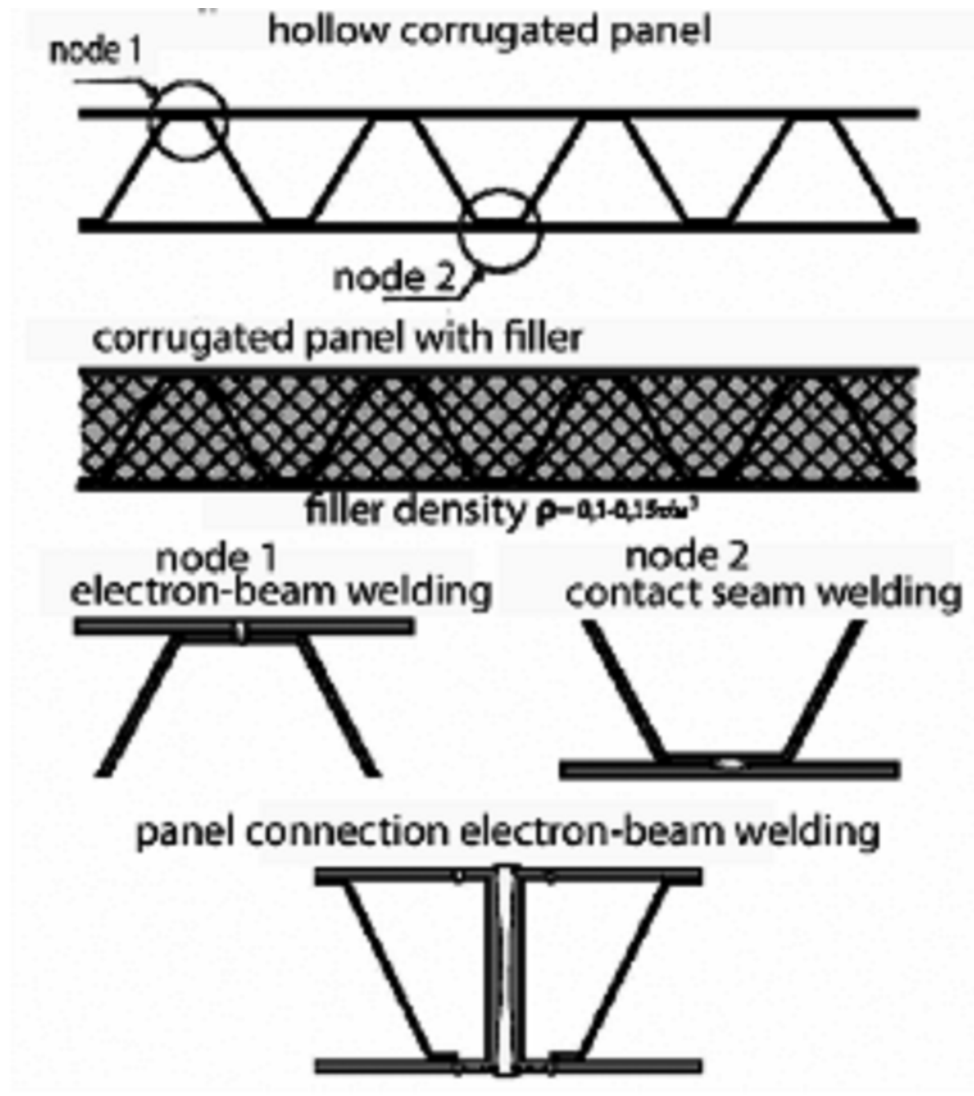

Figure 14-3 Electron beam welding of panels (Kryzhevich et al., 2005).

Summary of Emerging Technologies

- Friction stir welding is a relatively new technology
 - Found rapid application in the fabrication of lightweight marine structures
 - Primarily for joining integrally stiffened extrusions to make structural panels
- Laser welding and electron beam welding studies ongoing
 - Not used today for fabrication of aluminum marine structures.
- Laser stir welding may have some promise in the future