

**SSC-464**

**HIGH SPEED ALUMINUM VESSELS  
DESIGN GUIDE**



This document has been approved  
For public release and sale; its  
Distribution is unlimited

**SHIP STRUCTURE COMMITTEE**  
**2012**

# Ship Structure Committee

RADM P.F. Zukunft  
U. S. Coast Guard Assistant Commandant,  
Assistant Commandant for Marine Safety, Security  
and Stewardship  
Co-Chair, Ship Structure Committee

Mr. H. Paul Cojeen  
Society of Naval Architects and Marine Engineers

Mr. Christopher McMahon  
Director, Office of Ship Construction  
Maritime Administration

Mr. Kevin Baetsen  
Director of Engineering  
Military Sealift Command

Mr. Jeffrey Lantz,  
Commercial Regulations and Standards for the  
Assistant Commandant for Marine Safety, Security  
and Stewardship  
Mr. Jeffery Orner  
Deputy Assistant Commandant for Engineering and  
Logistics

RDML Thomas Eccles  
Chief Engineer and Deputy Commander  
For Naval Systems Engineering (SEA05)  
Co-Chair, Ship Structure Committee

Dr. Roger Basu  
Senior Vice President  
American Bureau of Shipping

Mr. Victor Santos Pedro  
Director Design, Equipment and Boating Safety,  
Marine Safety,  
Transport Canada

Dr. Neil Pegg  
Group Leader - Structural Mechanics  
Defence Research & Development Canada - Atlantic

Mr. Edward Godfrey  
Director, Structural Integrity and Performance Division

Dr. John Pazik  
Director, Ship Systems and Engineering Research  
Division

## SHIP STRUCTURE SUB-COMMITTEE

### AMERICAN BUREAU OF SHIPPING (ABS)

Mr. Craig Bone  
Mr. Phil Rynn  
Mr. Tom Ingram

### MARITIME ADMINISTRATION (MARAD)

Mr. Chao Lin  
Mr. Richard Sonnenschein

### NAVY/ONR / NAVSEA/ NSWCCD

Mr. David Qualley / Dr. Paul Hess  
Mr. Erik Rasmussen / Dr. Roshdy Barsoum  
Mr. Nat Nappi, Jr.  
Mr. Malcolm Witford

### UNITED STATES COAST GUARD

CAPT John Nadeau  
CAPT Paul Roden  
Mr. Jaideep Sirkar  
Mr. Chris Cleary

### DEFENCE RESEARCH & DEVELOPMENT CANADA ATLANTIC

Dr. David Stredulinsky  
Mr. John Porter

### MILITARY SEALIFT COMMAND (MSC)

Mr. Michael W. Touma  
Mr. Jitesh Kerai

### TRANSPORT CANADA

Natasa Kozarski  
Luc Tremblay

### SOCIETY OF NAVAL ARCHITECTS AND MARINE ENGINEERS (SNAME)

Mr. Rick Ashcroft  
Mr. Dave Helgerson  
Mr. Alex Landsburg  
Mr. Paul H. Miller

Member Agencies:

Address Correspondence to:

*American Bureau of Shipping  
Defense Research and Development Canada  
Maritime Administration  
Military Sealift Command  
Naval Sea Systems Command  
Office of Naval Research  
Society of Naval Architects & Marine Engineers  
Transport Canada  
United States Coast Guard*



**Ship  
Structure  
Committee**

COMMANDANT (CG-5212/SSC)  
ATTN (EXECUTIVE DIRECTOR/SHIP  
STRUCTURE COMMITTEE)  
US COAST GUARD  
2100 2ND ST SW STOP 7126  
WASHINGTON DC 20593-7126  
Website: <http://www.shipstructure.org>

**SSC – 464  
SR – 1465**

**NOVEMBER 30, 2011**

**DESIGN AND DETAILING FOR HIGH SPEED ALUMINUM VESSELS DESIGN GUIDE AND TRAINING**

As the commercial maritime industry and government organizations have increased their use and construction of high speed vessels, aluminum has gained popularity as a structural material given its high strength-to-weight ratio. Accordingly, it is imperative for the naval architect and marine designer community to be aware of the specific design considerations relevant to the incorporation of aluminum into marine vessels' structures, including fatigue, fracture, corrosion, heat effects, alloy selection and joint design.

This project develops a practical reference of key design considerations for the designer of large, high-speed aluminum vessels. An overview of the material properties of aluminum and aluminum alloys and the various manufacturing processes used in the fabrication of aluminum components are provided with an emphasis on design choices, considerations, and advantages / disadvantages. Vessel construction and joining processes, general and high speed loading, ultimate strength, fatigue and fracture, corrosion and fire resistance are all reviewed relative to implementation in high speed aluminum vessels. This project concluded with a training course, "Introduction to Design and Detailing for High-Speed Aluminum Vessels", based directly on the guide and was well received by attending engineers, designers and fabricators from industry and government. This training course and associated course materials are available from the Ship Structure Committee upon request.

We thank the authors and Project Technical Committee for their dedication and research toward completing the objectives and tasks detailed throughout this paper and continuing the Ship Structure Committee's mission to enhance the safety of life at sea.

  
P. F. ZUKUNFT  
Rear Admiral, U.S. Coast Guard  
Co-Chairman, Ship Structure Committee

  
T. J. ECCLES  
Rear Admiral, U.S. Navy  
Co-Chairman, Ship Structure Committee

1. Report No. 464	2. Government Accession No.	3. Recipient's Catalog No.	
4. Title and Subtitle  Design and Detailing for High Speed Aluminum Vessels Design Guide and Training		5. Report Date 1 June 2011	6. Performing Organization Code
		8. Performing Organization Report No. SR-1465	
7. Author(s) Mish, Wh, Jr., Lynch, T; Hesse E.; Kulis, J.; Wilde, J.; Snyder, Z.; Ruiz, F.		10. Work Unit No. (TRAIS)	
9. Performing Organization Name and Address Gryphon Technologies 80 M Street SE Suite 600 Washington, DC 20003		11. Contract or Grant No.	
		13. Type of Report  Final Report	
12. Sponsoring Agency Name and Address COMMANDANT (CG-5212/SSC) ATTN (SHIP STRUCTURE COMMITTEE) US COAST GUARD  2100 2ND ST SW STOP 7126 WASHINGTON DC 20593-7126		14. Sponsoring Agency Code  CG - 5	
		15. Supplementary Notes The research completed by the above author for the Ship Structure Committee was reviewed by the Project Technical Committee for satisfactory completion of the objectives outlined in the Statement of Work developed and approved for funding by the Principal Members of the Ship Structure Committee. Sponsored by the Ship Structure Committee and its member agencies	
16. Abstract  Aluminum is continuing to be increasingly considered as a structural material in design and construction of large high-speed vessels. This design guide has been developed to provide an overview of aluminum alloys and manufacturing and construction techniques and to identify design considerations that should be considered both during the vessel design and construction processes. Specifically, the guide describes the wrought and cast alloy and temper designation systems; the rolling, casting, extruding, and machining processes, riveting, bolting, welding, and adhesives as joining techniques; general and high speed loading; the ultimate strength of the ship structure; and fatigue, fracture, fire and corrosion as specific considerations for aluminum vessels.			
17. Key Words		18. Distribution Statement National Technical Information Service U.S. Department of Commerce Springfield, VA 22151 Ph. (703) 487-4650 / www.ntis.gov	
19. Security Classif. (of this report) Unclassified	20. Security Classif. (of this page) Unclassified	21. No. of Pages	22. Price

# **Table of Contents**

Table of Contents.....	i
List of Illustrations.....	vi
List of Tables.....	vi
List of Abbreviations and Symbols.....	vii
1. Scope.....	1
2. Referenced Documents.....	1
2.1. International Maritime Organization.....	1
2.2. American Bureau of Shipping.....	1
2.3. Det Norske Veritas.....	2
3. Overview.....	2
3.1. Purpose.....	2
3.2. Historical Perspective.....	2
3.3. Design Considerations.....	2
3.4. Design Manual Organization.....	3
4. Aluminum and Aluminum Alloys.....	4
4.1. Aluminum Properties and Considerations.....	4
4.2. Alloying Elements.....	4
4.3. Comparison of Alloys.....	9
5. Component Manufacturing Processes.....	14
5.1. Rolling.....	14
5.2. Casting.....	14
5.3. Extruding.....	16
5.4. Drawing.....	19
5.5. Machining.....	19
6. Vessel Construction.....	21
6.1. Riveting.....	21
6.2. Bolting.....	24
6.3. Welding.....	27
6.4. Adhesives.....	43
6.5. Structural Details.....	43
7. Ship Loading.....	45
7.1. Major Loads on the Hull Girder Model.....	45
7.2. Response of the Hull Girder Model to Loads.....	50
7.3. Dominant Load Parameters.....	51
7.4. Discussion of Aluminum Properties with Respect to Loading.....	52
7.5. High Speed Loads.....	53
8. Ultimate Strength of Ship Structure.....	60
8.1. Hull Girder Bending / Torsion.....	60
8.2. Buckling.....	61
8.3. Whipping.....	61
8.4. Deflections.....	62
9. Fire.....	64
9.1. Regulatory Requirements.....	64
9.2. Insulation.....	66
9.3. Current Research.....	67
10. General Discussion of Fatigue / Fracture.....	68
10.1. Elements of Fatigue Design.....	68
10.2. Design Methods.....	70
11. General Discussion of Corrosion.....	78
11.1. Types of Corrosion.....	78
11.2. Sensitization.....	79
11.3. Corrosion Control Methods.....	80
11.4. Corrosion Monitoring and Inspection.....	80

12. Conclusions .....	83
12.1. Further Reading .....	83
Glossary .....	84
References .....	86
Table of Contents .....	i
List of Illustrations .....	vi
List of Tables .....	vi
List of Abbreviations and Symbols .....	vii
1. Scope .....	1
2. Referenced Documents .....	1
2.1. International Maritime Organization .....	1
2.2. American Bureau of Shipping .....	1
2.3. Det Norske Veritas .....	2
3. Overview .....	2
3.1. Purpose .....	2
3.2. Historical Perspective .....	2
3.3. Design Considerations .....	2
3.3.1. Fatigue / Fracture .....	2
3.3.2. Corrosion .....	2
3.4. Design Manual Organization .....	3
4. Aluminum and Aluminum Alloys .....	4
4.1. Aluminum Properties and Considerations .....	4
4.1.1. Hydrogen Damage .....	4
4.2. Alloying Elements .....	4
4.2.1. Chromium (Cr) .....	4
4.2.2. Copper (Cu) .....	5
4.2.3. Magnesium (Mg) .....	5
4.2.4. Copper and Magnesium .....	5
4.2.5. Manganese (Mn) .....	5
4.2.6. Scandium (Sc) .....	5
4.2.7. Silicon (Si) .....	5
4.2.8. Silver (Ag) .....	6
4.2.9. Tin (Sn) .....	6
4.2.10. Titanium (Ti) .....	6
4.2.11. Zinc (Zn) .....	6
4.2.12. Zirconium (Zr) .....	6
4.2.13. Summary of Alloying Elements .....	9
4.3. Comparison of Alloys .....	9
4.3.1. Alloy and Temper Designations .....	9
4.3.1.1. Wrought Alloy Designation System .....	9
4.3.1.2. Cast Alloy Designation System .....	11
4.3.1.3. Temper Designation System .....	12
5. Component Manufacturing Processes .....	14
5.1. Rolling .....	14
5.1.1. Rolling Process .....	14
5.1.2. Plate Products .....	14
5.1.3. Sheet Products .....	14
5.1.4. Specialty Flat Products .....	14
5.1.5. Constraints / Considerations .....	14
5.2. Casting .....	14
5.2.1. Casting Processes .....	15
5.2.1.1. Permanent Mold Casting .....	15
5.2.1.2. Die Casting .....	15
5.2.1.3. Sand Casting .....	15

5.2.2.	Inspection / Testing .....	15
5.2.2.1.	Permanent Mold Casting .....	15
5.2.2.2.	Die Casting .....	15
5.2.2.3.	Sand Casting .....	15
5.2.3.	Constraints / Considerations .....	15
5.2.3.1.	Permanent Mold Casting .....	15
5.2.3.2.	Die Casting .....	16
5.2.3.3.	Sand Casting .....	16
5.3.	Extruding .....	16
5.3.1.	The Hot Extrusion Process .....	16
5.3.1.1.	Profile Design / Material Selection .....	16
5.3.1.2.	Die <sup>†</sup> Design / Manufacturing .....	17
5.3.1.3.	Material Preparation .....	18
5.3.2.	Constraints / Considerations .....	18
5.3.2.1.	Extrusion Type .....	18
5.3.2.2.	Billet Size .....	18
5.3.3.	Optimization .....	18
5.3.4.	Post-Processing .....	19
5.4.	Drawing .....	19
5.5.	Machining .....	19
5.5.1.	Common Machining Operations .....	19
6.	Vessel Construction .....	21
6.1.	Riveting .....	21
6.1.1.	Advantages and Disadvantages .....	21
6.1.2.	Material Selection .....	21
6.2.	Bolting .....	24
6.2.1.	Advantages and Disadvantages .....	24
6.2.2.	Material Selection .....	25
6.2.3.	Installation Considerations .....	25
6.2.4.	Requirements .....	25
6.2.5.	Bolt Pull Through and Tear Out .....	26
6.3.	Welding .....	27
6.3.1.	Processes .....	27
6.3.1.1.	Gas Metal Arc Welding (GMAW) .....	27
6.3.1.2.	Gas Tungsten Arc Welding (GTAW) .....	28
6.3.1.3.	Friction Stir Welding (FSW) .....	28
6.3.1.4.	Explosion Welding .....	29
6.3.2.	Design for Welding .....	30
6.3.2.1.	Material Considerations .....	30
6.3.2.2.	Weldability .....	30
6.3.2.3.	Weld Strength .....	30
6.3.2.4.	Hydrogen Solubility .....	30
6.3.2.5.	Electrical Conductivity .....	34
6.3.2.6.	Thermal Conductivity .....	34
6.3.3.	Preparation / Cleaning .....	34
6.3.3.1.	Removal of Oxidation .....	34
6.3.3.2.	Removal of Anodization Coatings .....	34
6.3.3.3.	Preheating .....	34
6.3.3.4.	Precipitation .....	34
6.3.3.5.	Joint Design .....	35
6.3.4.	Filler Alloy Selection .....	36
6.3.5.	Residual Stresses .....	38

Residual stresses must be calculated and determined to verify joint strength as well as ensure there is enough supporting structure near the welded joint. Residual stress weakens the joint by putting stresses already in place, and

creating a greater chance of failure from fatigue. If the joint can be properly designed, the pre-stresses can be eliminated or incorporated into the overall design.....	38
6.3.5.1. Distortion .....	39
6.3.6. Grinding.....	40
6.3.7. Finishing.....	40
6.3.8. Inspection / Testing .....	40
6.3.9. Bimetallic Transition Inserts .....	41
6.3.10. Design Requirements.....	41
6.3.11. Welder Certification .....	42
6.4. Adhesives .....	43
6.5. Structural Details.....	43
6.5.1. Joining Aluminum Structure to Steel .....	44
7. Ship Loading.....	45
7.1. Major Loads on the Hull Girder Model.....	45
7.1.1. Static Loads .....	45
7.1.2. Low-Frequency Dynamic Loads .....	45
7.1.3. High-Frequency Dynamic Loads.....	46
7.1.3.1. Shaft Line / Propeller Loads.....	46
7.1.4. Impact Loads .....	46
7.1.5. Other Sources of Operational Ship Loads .....	46
7.1.5.1. Tank Loads.....	46
7.1.5.2. Live and Dead Loads .....	47
7.1.5.3. Equipment / Point Loading .....	47
7.1.5.4. Sea Loads .....	48
7.1.5.5. Weather / Ice Loads .....	48
7.1.5.6. Ship Motion Loads .....	48
7.1.5.7. Flooding .....	48
7.1.5.8. Accidental Loads.....	49
7.1.5.9. Aircraft.....	49
7.1.5.10. Docking, Mooring, and Dry-Docking .....	50
7.1.5.11. Point Loads from Tugs, Pilot Boats, Piers, etc.....	50
7.2. Response of the Hull Girder Model to Loads.....	50
7.3. Dominant Load Parameters .....	51
7.4. Discussion of Aluminum Properties with Respect to Loading.....	52
7.4.1. Vibration.....	52
7.5. High Speed Loads .....	53
7.5.1. Design Process.....	53
7.5.1.1. Sea States .....	53
7.5.1.2. Speed.....	55
7.5.1.3. Vertical Accelerations.....	55
7.5.1.4. Slamming Pressures – Monohulls .....	56
7.5.1.5. Slamming Pressures – Multihulls, SES, SWATH, & ACV .....	57
7.5.1.6. Required Plating Thicknesses and Structural Scantlings .....	58
8. Ultimate Strength of Ship Structure.....	60
8.1. Hull Girder Bending / Torsion .....	60
8.2. Buckling .....	61
8.3. Whipping.....	61
8.4. Deflections .....	62
9. Fire.....	64
9.1. Regulatory Requirements .....	64
9.1.1. SOLAS .....	64
9.1.2. IMO HSC .....	65
9.1.3. USCG .....	66
9.1.4. US Navy .....	66
9.2. Insulation.....	66



9.3.	Current Research .....	67
10.	General Discussion of Fatigue / Fracture .....	68
10.1.	Elements of Fatigue Design .....	68
10.1.1.	Step 1: Establish if Fatigue May Be Controlling .....	68
10.1.2.	Step 2: Minimize or Prevent Cyclic Loads .....	68
10.1.3.	Step 3: Determine and Estimate Cyclic Loads .....	68
10.1.4.	Step 4: Determine Fatigue-Critical Sites and Estimate Stresses .....	68
10.1.5.	Step 5: Select Analysis and Design Method .....	68
10.1.6.	Step 6: Prepare Preliminary Design .....	69
10.1.7.	Step 7: Evaluate Robustness and Cost .....	70
10.1.8.	Step 8: Verify Design by Test .....	70
10.2.	Design Methods .....	70
10.2.1.	S-N .....	70
10.2.1.1.	Safe-Life Design .....	70
10.2.1.2.	Infinite Life Design .....	71
10.2.1.3.	Mean Stress .....	71
10.2.1.4.	Environmental Effects .....	71
10.2.2.	Hot Spot Method .....	72
10.2.3.	Strain-Life Method .....	73
10.2.4.	Fracture Mechanics .....	74
10.2.4.1.	Structural Analysis .....	74
10.2.4.2.	Initial Flaw Size .....	75
10.2.4.3.	Stress Intensity Solutions .....	75
10.2.4.4.	Loading Profile .....	75
10.2.4.5.	Material Response .....	75
10.2.4.6.	Fatigue Life Prediction .....	76
10.2.5.	Good Practice .....	76
10.2.6.	Selection of Method .....	76
10.2.7.	Inspection Plans for Structural Fatigue Deterioration .....	76
11.	General Discussion of Corrosion .....	78
11.1.	Types of Corrosion .....	78
11.1.1.	Uniform Corrosion .....	78
11.1.2.	Pitting .....	78
11.1.3.	Stress Corrosion Cracking (SCC) .....	78
11.1.4.	Intergranular Corrosion .....	78
11.1.5.	Exfoliation Corrosion .....	79
11.1.6.	Crevice Corrosion .....	79
11.1.7.	Galvanic Corrosion .....	79
11.2.	Sensitization .....	79
11.3.	Corrosion Control Methods .....	80
11.3.1.	Inhibitors .....	80
11.3.2.	Surface Treatments .....	80
11.3.3.	Coatings and Sealants .....	80
11.3.4.	Cathodic Protection .....	80
11.4.	Corrosion Monitoring and Inspection .....	80
11.4.1.	Corrosion Monitoring .....	80
11.4.2.	Corrosion Inspection .....	81
11.4.3.	Corrosion Testing .....	81
11.4.3.1.	ASTM B117 .....	81
11.4.3.2.	ASTM G31 .....	81
11.4.3.3.	ASTM G34 .....	81
11.4.3.4.	ASTM G44 .....	81
11.4.3.5.	ASTM G46 .....	81
11.4.3.6.	ASTM G47 .....	81
11.4.3.7.	ASTM G50 .....	81

11.4.3.8.	ASTM G66.....	81
11.4.3.9.	ASTM G67.....	81
11.4.3.10.	ASTM G69.....	82
11.4.3.11.	ASTM G71.....	82
11.4.3.12.	ASTM G85.....	82
11.4.3.13.	ASTM G103.....	82
11.4.3.14.	ASTM G104.....	82
11.4.3.15.	ASTM G110.....	82
11.4.3.16.	ASTM G116.....	82
11.4.3.17.	GM9540P.....	82
12.	Conclusions.....	83
12.1.	Further Reading.....	83
	Glossary.....	84
	References.....	86

## **List of Illustrations**

Figure 1.	Solid Extrusion Die Assembly (7).....	17
Figure 2.	Porthole Hollow Die (7).....	18
Figure 3.	Pancake Hollow Die (7).....	18
Figure 4.	GMAW Welding Equipment (63).....	28
Figure 5.	GMAW Weld Tip (114).....	28
Figure 6.	Principles of GTAW (66).....	28
Figure 7.	Schematic Diagram of GTAW System (66).....	28
Figure 8.	Schematic Diagram of the FSW Process (58).....	29
Figure 9.	Explosion Clad Plate Manufacturing Process (57).....	29
Figure 10.	Common Butt Joints (125).....	35
Figure 11.	Common Corner Joints (125).....	36
Figure 12.	Common Tee Joints (125).....	36
Figure 13.	Common Lap Joints (125).....	36
Figure 14.	Common Edge Joint Application (125).....	36
Figure 15.	Options for the Welding Symbol Commonly Used in Manufacturing (88).....	42
Figure 16.	Ship Structural Loads.....	45
Figure 17.	Loaded Plate Design Curves (73).....	48
Figure 18.	Typical Vessel Shear / Bending Moment Diagram.....	51
Figure 19.	Sea States (98).....	54
Figure 20.	Comparative Operating Envelopes of 1000-ton Ships (58).....	55
Figure 21.	Pressure Reduction Coefficient ( $K_D$ ) for Planing Hulls and Hydrofoil Hulls (3).....	57
Figure 22.	Longitudinal Pressure Distribution Factor (F) for Planing Hulls and Hydrofoil Hulls (3).....	57
Figure 23.	Pressure Reduction Coefficient ( $K_D$ ) for SES, ACV and SWATH Vessels (3).....	58
Figure 24.	Longitudinal Pressure Distribution Factor (F) for SES, ACV and SWATH Vessels (3).....	58
Figure 25.	Aluminum Tensile Strength Variation Versus Temperature.....	64
Figure 26.	Hot Spot Stress Interpolation Diagram (14).....	72
Figure 27.	Reversals to Failure, $2N_f$ (log scale) (120).....	74
Figure 28.	Modes of Crack Extension (120).....	75
Figure 29.	Crack Propagation Data for Variable-Amplitude Loading (113).....	75
Figure 30.	Electrical Potential of Common Metals (39).....	79

## **List of Tables**

Table 1.	Aluminum Purity (53).....	4
Table 2.	Summary of Alloying Elements.....	8
Table 3.	Mechanical Properties of Common Marine Aluminum Alloys (115) (53).....	10
Table 4.	Wrought Aluminum Alloy Series General Properties (53).....	11

Table 5.	Cast Aluminum Alloy Series General Properties (53) .....	12
Table 6.	Aluminum Alloy Temper Designations (17).....	13
Table 7.	Advantages and Disadvantages of Joining Methods .....	22
Table 8.	Physical Properties and Weldability of Common Aluminum Alloys (53) .....	31
Table 9.	Filler Alloy Characteristics .....	37
Table 10.	Welder Qualification Tests Descriptions .....	43
Table 11.	Typical Live Loading Intensities (95).....	47
Table 12.	Range of Applicability for Vertical Acceleration Parameters (110).....	56
Table 13.	SOLAS Structural Division Classifications (75) .....	65
Table 14.	Structural Fire Protection Times for Separating Bulkheads and Decks of Passenger Craft (74).....	66

## **List of Abbreviations and Symbols**

a	Plating length		
A	Shear area	$\Delta$	Seawater displacement using the design waterline
AA	Aluminum Association	$\Delta\varepsilon$	Strain range, total strain amplitude
ABS	American Bureau of Shipping	$\Delta\varepsilon_e$	Strain range, elastic strain amplitude
ACV	Air Cushion Vehicle	$\Delta\varepsilon_p$	Strain range, plastic strain amplitude
$A_D$	Structural design area	$\Delta_i$	Virtual displacement including added mass
AEC	Aluminum Extruders' Council	$\Delta K$	Stress intensity range
$A_n$	Area of weld joint	$\Delta_{LT}$	Full load displacement in long tons
AR	Aspect ratio	$\Delta q$	Change in load due to hull girder deflection
$A_R$	Reference area	$\delta x$	Tolerance for x
$A_{wi}$	Reference area of the ship's surface exposed to wind	D	Nominal bolt diameter
$\alpha$	Angle of rotation	$D_{edge}$	Distance from center of bolt to plate edge
$\alpha_i$	See definition, Equation (83)	$D_h$	Rivet hole diameter
ASD	Allowable Stress Design	DSC	Dynamically Supported Craft
ASM	American Society for Metals	d	Full load static draft
b	Beam	$d_e$	Distance from edge to rivet / bolt in the direction of applied force
$b_{pl}$	Plate length	$\partial F/\partial x$	The partial derivative of the function F with respect to x
$b_s$	Stiffener spacing	E	Elastic modulus
$b(x)$	Buoyancy force per unit length	EPC	Evaporative Pattern Casting
$\beta$	Deadrise angle	EXCO	Exfoliation Corrosion
$b_{avg}$	Average breadth of contact area over grounded length	$\varepsilon'_f$	Fatigue ductility coefficient
$B_{PX}$	Maximum chine beam	F	Longitudinal pressure distribution factor
$B_{amid}$	Breadth at amidships	f	Core insulation reduction coefficient
C	Constant or coefficient (usage varies)	$f(x)$	Downward forces
$C_B$	Block coefficient at summer load waterline	$F_C$	Insulation value protecting core
CCD	Circumscribing circle diameter	$f_d$	Fatigue ductility exponent
$C_\Delta$	Static beam loading coefficient	Fe	Iron
$C_f$	See definition, Equation (79)	FE	Finite Element
$CFL(\varphi_{wi})$	Coefficients which depend on the shape of the exposed part of the ship and on angle $\varphi_{wi}$ (see definitions, Equation (40))	$F_E$	Insulation value on exposed side
$CFT(\varphi_{wi})$		FEA	Finite Element Analysis
$Cmz(\varphi_{wi})$		FEM	Finite Element Model
CP	Cathodic protection	FRP	Fiber Reinforced Plastic
Cr	Chromium	$f_s$	Fatigue strength exponent
Cu	Copper	$F_{su}$	Rivet shear ultimate strength
c	Crack length	$F_{sw}$	Maximum hull girder shear force in stillwater
$c_f$	Final crack length	$F_{tu}$	Ultimate tensile strength of connected part in
$c_i$	Initial crack length		
$\nabla$	Volumetric displacement using the design		

	riveted / bolted joint		area
FSW	Friction Stir Welding	$p(x)$	Upward supporting forces
$F_U$	Insulation value on unexposed side	$P_D$	Uniform static design pressure
$G's$	Unit of acceleration	$P_{max}$	Maximum grounding pressure
$G$	Strain energy release rate	$P_M$	Maximum slamming pressure over the impact reference area
$G_{rig}$	Modulus of rigidity	$P_N$	Bolt force normal to plate
$\Gamma$	Saint-Venant torsional constant	$P_P$	Bolt force parallel to plate
$\gamma$	Density of water	ppm	Parts Per Million
GMAW	Gas Metal Arc Welding	$q$	Weld heat input per length
$G_{sm}$	Shear modulus	$q(x)$	Load per unit length
GTAW	Gas Tungsten Arc Welding	$R$	Stress ratio
$H$	Proportion of arc energy transferred to weld work piece as heat	RAO	Response Amplitude Operator
$H_{1/3}$	Significant wave height in an irregular sea state (based on 1/3 highest waves)	$R_{ground}$	Ground reaction force
$I$	Arc current	$R_n/\Omega$	Rivet / bolt allowable stress (ASD Method)
$I_H$	Hull moment of inertia	$r$	Lockwood Taylor's shear correction factor
IMO	International Maritime Organization	$r_x$	See definition, Equation (52)
$J$	Energy release rate	$s$	Longitudinal spacing
$J_{tor}$	Section torsional constant	SAE	Society of Automotive Engineers
$K$	Stress intensity	SCC	Stress Corrosion Cracking
$K_D$	Pressure reduction coefficient	$s_{cont}$	Contour coordinate
$L$	Seam length	SES	Surface Effect Ship
LBP	Length between perpendiculars	$Si$	Silicon
$l_f$	Effective length of transverse frames	$s_i$	Impact stress
$l_g$	Grounded length	SM	Section modulus
LWL	Length along the Waterline	$Sn$	Tin
LPPM	Low Pressure Permanent Mold	SNAME	Society of Naval Architects and Marine Engineers
LRFD	Load and Resistance Factor Design	SOLAS	Safety Of Life At Sea
$m$	Slope of the S-N curve	$S_{rd}$	Allowable stress range
Mg	Magnesium	$S_{re}$	Equivalent stress range
MIG	Metal Inert Gas	$S_{ri}$	$i$ th stress range in the spectrum
MMA	Methamethacrylate	$s_s$	Static stress
Mn	Manganese	SSC	Ship Structure Committee
MPEV	Most Probable Extreme Value	$\sigma$	Allowable stress
$M_{sw}$	Stillwater bending moment	$\sigma_0$	Uniform tensile stress
$M(x_1)$	Bending moment at $x_1$	$\sigma'_f$	Fatigue stress coefficient
$n$	Structural node	$\sigma_m$	Mean stress
$N$	Number of cycles	$\sigma_{PT}$	Bolt pull-through stress
NAVSEA	Naval Sea Systems Command	$\sigma_{TO}$	Bolt tear-out stress
$2N_f$	Number of reversals to failure	$\sigma_y$	Material yield stress
$n_{long}$	See definition, Equation (68)	$\sigma_{y0}$	Transverse stress on weld seam
$N_s$	Number of stress ranges in the spectrum	SWATH	Small Waterplane Area Twin Hull
$\nu$	Poisson's ratio ( $\nu$ )	$\tau$	Shear stress
$N_w$	First vertical whipping frequency	$\theta$	Angle of weld joint
NSRP	National Shipbuilding Research Program	$\theta_0$	Constant of integration (see Equation (77))
NVIC	Navigation and Vessel Inspection Circulars	Ti	Titanium
NVR	Naval Vessel Rules	TIG	Tungsten Inert Gas
$N_z$	Vertical acceleration	$T_m$	Total twist moment
$\Omega$	ASD Design Constant (ASD Method)	$t$	Plate / sheet thickness
$\Phi$	LRFD Design Constant (LRFD Method)	$t_{cp}$	Thickness of connecting part in rivet / bolt joint design
$\Phi_{R_n}$	Rivet / Bolt Design Stress (LRFD Method)	$\tau$	Trim angle of planing area
$\phi_{wi}$	Angle of acting environmental forces	$\Theta$	Twist angle
$P$	Pressure exerted by equipment	U	Strain energy
$\bar{P}$	Average slamming pressure over reference		

$V$	Arc Voltage
$V(x_1)$	Shear force at $x_1$
$V_K$	Speed, knots
$V_{wi}$	Acting force speed
$v$	Welding speed
$[v]$	Dislocation
$w$	Plate / sheet width
$w(x)$	Weight per unit length
$W_b$	Weight of impacting object
$W_i$	Weight of impacted mass
$w_f$	Transverse frame spacing
$W_L$	Vessel gross weight
$w_p$	Permanent set
$y$	Deflection
$y_b$	Bending deflection
$y_s$	Shear deflection
$y_{tx}$	Total deflection at length $x$ along the ship
$y_x$	Breadth of the hull at the waterline and at a length $x$
$y_0$	Constant of integration (see Equation (77))
Zn	Zinc
Zr	Zirconium

# INTRODUCTION

Aluminum has become popular as a structural material in many industries, and the maritime industry is no exception. Shortly after a smelting process was discovered and made aluminum a commercially available material, it was being used experimentally in the construction of marine vessels. Throughout the decades since that time, aluminum has been used in a number of different ships with varying levels implementation and varying degrees of success.

The wide range of success in incorporating aluminum into the structural design has been a result of the level of understanding of the properties of the alloys and the ability of the designer to take advantage of the positive aspects while avoiding pitfalls and carefully designing around the considerations that are inherent in aluminum vessel design.

Recently, as the commercial maritime industry and government organizations have begun constructing high speed vessels, aluminum has gained popularity as a structural material due to its high strength-to-weight ratio. However, ship designs must also consider the other properties of aluminum.

This design guide has been written to provide a practical overview of the design process for large, aluminum high-speed vessels. It describes aluminum alloys, the manufacturing and joining processes for aluminum, and the vessel structural design and construction process.

## 1. Scope

This design guide has been written to aid in the design and construction of large, high-speed aluminum vessels. For the purposes of the information contained within the guide, the following definitions of *large* and *high-speed* have been used:

*large adj.* – with respect to vessel size, having a length along the waterline (LWL) of 150 feet (~45.72 meters) or more

*high-speed adj.* – with respect to vessel speed, being capable of a maximum speed equal to or exceeding (74):

$$3.7\nabla^{0.1667} \quad \text{m/s} \quad (1)$$
$$7.16\Delta^{0.1667} \quad \text{knots} \quad (2)$$

Where:

- $\nabla$  = the displacement in cubic meters (m<sup>3</sup>) corresponding to the design waterline
- $\Delta$  = the displacement in seawater in tonnes corresponding to the design waterline

These definitions have been used to define the scope of this guide; however, when ensuring compliance with regulatory requirements, the definitions prescribed in the requirements shall be used.

## 2. Referenced Documents

The following documents are referenced within the text using the following acronyms (all referenced documents are listed in References):

### 2.1. International Maritime Organization

IMO HSC<sup>1</sup> – International Code of Safety for High Speed Craft (74)

SOLAS<sup>2</sup> – Safety of Life at Sea (75)

### 2.2. American Bureau of Shipping

ABS ALUM – Rules for Building and Classing Aluminum Vessels (13)

---

<sup>1</sup> The International Code of Safety for High-Speed Craft (HSC Code 2000) was adopted by the IMO Maritime Safety Committee (MSC) by resolution MSC 97(73) on December 5, 2000 and went into effect for vessels constructed after July 1, 2002. It was preceded by the 1994 HSC Code, which was preceded by the 1977 Code of Safety for Dynamically Supported Craft (DSC). The DSC was based on the management of risk through accommodation arrangement, active safety systems, and restricted operations.

<sup>2</sup> The International Convention for the Safety of Life at Sea was formed following the sinking of the *Titanic*. The most recent set of requirements was adopted on 1 November, 1974 by the International Maritime Organization. It has been amended a number of times; all of the requirements including amendments are combined into a single consolidated edition in 2009, which is the edition used in this guide. The responsibility of enforcing the requirements belongs to the government whose flag the vessel sails under (referred to as the Administration in SOLAS). In the United States, the duty of enforcing SOLAS generally falls to the Coast Guard.

ABS HSC – Guide for Building and Classing High Speed Craft (9)

ABS HSNV – Guide for Building and Classing High Speed Naval Vessels (10)

ABS NVR – Guide for Building and Classing Naval Vessels (11)

### 2.3. *Det Norske Veritas*

DNV HSLC – Rules for Classification of High Speed, Light Craft and Naval Surface Craft (55)

## 3. Overview

### 3.1. Purpose

The purpose of the design guide is to provide a practical reference for the designer of large, high-speed aluminum vessels. In the past, there have been problems encountered while attempting to use aluminum as a structural material. Some of these problems have been the result of misunderstanding about the capabilities and considerations of aluminum. This guide is intended to reduce these misunderstandings while summarizing the current state of knowledge concerning applications of aluminum in the marine industry.

### 3.2. Historical Perspective

As compared to the historical use of other metals such as iron or bronze, the history of aluminum is relatively short. It was first isolated as minute particles by the Danish scientist Hans Oersted in 1825. Friedrich Wöhler, a professor of chemistry at Göttingen University in Germany, reproduced Oersted's experiments and later produced the first aluminum nuggets, which demonstrated some of the properties of the element. The French chemist Henri Ste-Claire Deville made aluminum a more commercially viable material by developing an extraction process which relied on sodium rather than the rare potassium that Wöhler's process used. The greatest leap in the development of aluminum came in 1886 when two scientists – Charles M. Hall from America and Paul Héroult from France – independently developed a smelting<sup>†</sup> process for aluminum. Héroult received a patent for the process two months prior to Hall. Their method used molten cryolite as the electrolyte and electricity, which was becoming common at the time. Later, Karl Bayer of Germany developed a process for obtaining alumina – the raw material for the Hall-Héroult process – from bauxite<sup>3</sup>, the naturally occurring aluminum ore (56).

<sup>3</sup> Words followed by a dagger (†) are included in the Glossary

Initially, aluminum was used only experimentally on small craft. The first vessel of significant size to use aluminum was the *Vendensesse*, a sloop-rigged yacht built in France in 1892. Plating composed of a 6% aluminum copper aluminum alloy comprised the shell plating, decks, and bulkheads which were riveted to the steel frames, keel, and stringers. After corrosion was observed over 20 m<sup>2</sup> (~215 ft<sup>2</sup>) of the bottom plating within four months of launch, a special paint was developed to prevent further corrosion (70) (115).

Within the US, the first vessel of significant size to use aluminum was the *Defender*, an America's Cup yacht built in 1895. Pittsburgh Reduction Co's Nickel Aluminum alloy, composed of 4% nickel, comprised the side shell plating and some of the frames. The shell plating below the waterline was composed of bronze. Galvanic corrosion between the bronze and aluminum caused deterioration of the aluminum (70) (87) (115).

Over the decades following the construction of these two vessels, aluminum has been used in a number of different vessels with varying levels of success. Recently, aluminum has become popular in the construction of large, high-speed ferries. These vessels have become so successful that the U.S. Navy has begun construction of large, aluminum high speed vessels.

### 3.3. Design Considerations

There are several considerations which factor into the decisions made throughout the structural design process: fatigue, fracture, and corrosion. Nearly every part of this guide describes different options or solutions – e.g. alloy selection, joint design, structural details, etc. – which must be selected while taking into account these three items.

#### 3.3.1. Fatigue / Fracture

Fatigue and fracture are especially relevant considerations for the construction of aluminum ships since the vessel experiences a range of load magnitudes from a variety of sources throughout its lifetime. Section 1 discusses analysis options for designing aluminum vessels while considering fatigue.

#### 3.3.2. Corrosion

Corrosion is an important issue to consider when designing any component, system, or structure. This is especially true in the marine environment because the environmental conditions accelerate the progression of corrosion. Section 10.2.7 of this document will discuss the various forms of corrosion to consider as well as the methods to control, monitor, inspect, and test items for corrosion. By utilizing these methods, a suitable design can be established that will meet or exceed the intended life of an item.

### *3.4. Design Manual Organization*

The remainder of this design guide is organized into the following sections:

- Section 1 describes aluminum and aluminum alloys. It lists common alloying elements and describes the affect(s) of their addition to an alloy. Section 1 also details the designation systems for wrought and cast aluminum and aluminum alloys.
- Section 5 includes information about each of the different manufacturing processes used to produce aluminum components. Each subsection describes the process and lists design considerations and how they factor into the design process.
- Section 1 describes the multiple methods of assembling aluminum structures. Also, included is information about joining aluminum components and structures to components and structures composed of other materials.
- Section 1 begins the second half of the guide in which the information in the previous sections is applied to the process of designing and constructing ships. Section 1 describes the various loads which must be considered during the structural design process.
- Section 1 applies the loads described in Section 1 in order to evaluate the strength of the ship structure.
- Section 1 is the first of three sections which describe design considerations which are important when design aluminum structures. This section describes the susceptibility of aluminum to fire damage and the design process that is necessary to protect the structure.
- Section 1 is focused on fatigue and fracture. This section describes different analysis methods for fracture and fatigue life.
- Section 10.2.7 provides a discussion of corrosion. The various types of corrosion are described as well as methods for corrosion testing, monitoring, and inspection.
- Section 1 provides concluding remarks and suggestions for further reading.



#### 4. Aluminum and Aluminum Alloys

Aluminum is the most abundant metal in the earth's crust. However, pure aluminum does not have significant strength; therefore, it is alloyed with other elements. The ratios in which the elements are combined yields a vast range of aluminum alloys with varying properties to meet the criteria for a wide range of applications.

There is no adopted nomenclature for defining aluminum purity, but Table 1 shows the classification that is considered the most common:

**Table 1. Aluminum Purity (53)**

Aluminum %	Designation
99.50 - 99.79	Commercial purity
99.80 - 99.949	High purity
99.950 - 99.9959	Super purity
99.996 - 99.9990	Extreme purity
>99.9990	Ultra purity

There is also a classification of primary versus secondary aluminum. Primary aluminum is the initial composition of the aluminum. Secondary aluminum is defined as a recycled aluminum.

##### 4.1. Aluminum Properties and Considerations

One of the reasons why aluminum is such a popular metal in the engineering industry is due to the wide range of physical and mechanical properties that can be developed by alloying. Aluminum is soft, durable, lightweight, and ductile. It has a density of approximately one-third of that of steel. However, aluminum also has a lower modulus of elasticity than that of steel. The result of this is demonstrated when both materials are equally loaded; the aluminum part will deflect more than the steel part. Aluminum by itself also has good corrosion resistance due to a thin surface layer of aluminum oxide that forms when the metal is exposed to air, essentially preventing further oxidation.

##### 4.1.1. Hydrogen Damage

A generic name given to a large number of metal degradation processes due to interaction with hydrogen is called "hydrogen damage." The most damaging effect of hydrogen in structural materials is known as hydrogen embrittlement. Hydrogen embrittlement is the process by which various metals become brittle and fracture following exposure to hydrogen. Hydrogen embrittlement is often the result of unintentional introduction of hydrogen into susceptible metals during forming or finishing operations. Materials susceptible to this process exhibit a marked decrease in their energy absorption ability before fracture in

the presence of hydrogen<sup>4</sup>. The embrittlement is enhanced by slow strain rates and low temperatures, near room temperature. Mechanisms that can integrate external hydrogen into the material include cathodic protection, phosphating, pickling, electroplating, arc welding (see also Section 6.3.1), galvanic corrosion (see Section 11.1.7), and chemical reactions of metals with acids, or with other chemicals (93).

Hydrogen dissolves in all metals to a moderate extent. As it is a very small atom, it fits easily between the metal atoms in the crystals of the metal. Consequently, it can diffuse much more rapidly than larger atoms. Hydrogen tends to be attracted to regions of high triaxial tensile stress where the metal structure is dilated. Thus, it is drawn to the regions ahead of cracks or notches that are under stress. The dissolved hydrogen then assists in the fracture of the metal, either by making cleavage easier or by assisting in the development of intense local plastic deformation. These effects lead to embrittlement of the metal; cracking may be either inter- or transgranular. Crack growth rates are typically relatively rapid, up to 1 mm/s in the most extreme cases (93).

Aluminum alloys are susceptible to hydrogen embrittlement; although, the microstructure causes the transport of hydrogen to be slower than in high strength steels, and, hence, the crack growth rate may be lower. The cracking in aluminum due to hydrogen embrittlement is normally intergranular. As with steels, the susceptibility becomes more severe as the strength of the alloy is increased; however, there is also a strong effect of heat treatment and microstructure, and quite high strengths can be obtained with good stress corrosion cracking (SCC) resistance. Any environments that can provide hydrogen can lead to SCC of susceptible alloys, ranging from humid air to salt solution (93).

##### 4.2. Alloying Elements

As stated previously, pure aluminum is not very strong, having a tensile yield strength of approximately 4.0 ksi / 28 MPa. It is, therefore, typically alloyed with other elements. The following sections describe the most common elements that are used in aluminum alloys.

##### 4.2.1. Chromium (Cr)

Chromium occurs as a minor impurity – five to fifty parts per million (ppm) – in commercial-purity aluminum and has a large effect on electrical resistivity. Increasing chromium increases electrical resistivity. Chromium is a common addition to many alloys of the aluminum-magnesium,

<sup>4</sup> This phenomenon is also known as hydrogen-assisted cracking or hydrogen-induced blister cracking.

aluminum-magnesium-silicon, and aluminum-magnesium-zinc groups, in which it is added in amounts generally not exceeding 0.35%<sup>5</sup>. Chromium has a slow diffusion rate and forms finely dispersed phases in wrought products. These dispersed phases inhibit nucleation and grain growth. Chromium is used to control grain structure, to prevent grain growth in aluminum-magnesium alloys, and to prevent recrystallization in aluminum-magnesium-silicon or aluminum-zinc alloys during hot working or heat treatment. The fibrous structures that develop reduce stress corrosion susceptibility and/or improve toughness. Chromium in solid solution and as a finely dispersed phase increases the strength of alloys slightly. The main drawback of chromium in heat-treatable alloys is the increase in quench sensitivity when the hardening phase tends to precipitate in pre-existing chromium-phase partials (53).

#### 4.2.2. Copper (Cu)

Aluminum-copper alloys include copper – 2% to 10% – generally with other additions form an important family of alloys. Both cast and wrought aluminum-copper alloys respond to solution heat treatment and subsequent aging with an increase in strength and hardness<sup>†</sup> and a decrease in elongation. The strengthening is maximized when copper is added between 4% and 6%, depending upon the influence of other constituents present (53). Copper additions in quantities greater than 0.1% may cause pitting when submerged. A good example of this is 6061, which has 0.15% to 0.40% copper; an alternative is 6082, which has a maximum of 0.10% copper.

#### 4.2.3. Magnesium (Mg)

Magnesium is the major alloying element in the 5xxx series of alloys. Its maximum solid solubility in aluminum is 17.4%, but the magnesium content in current wrought alloys does not exceed 5.5%. Magnesium precipitates preferentially at grain boundaries as a highly anodic phase, which increases susceptibility to intergranular cracking and to stress corrosion thus the weight of magnesium is kept below the 5.5% by weight measure. Wrought alloys containing magnesium – up to 5% – when properly fabricated are stable under normal usage. The addition of magnesium markedly increases the strength of aluminum without unduly decreasing the ductility<sup>†</sup>. Corrosion resistance and weldability are good. The addition of magnesium and manganese in wrought alloys, in the right combination, yields high strength in the work-hardened condition, high resistance to corrosion, and good welding characteristics. Increasing the amounts of either magnesium or manganese intensifies the difficulty of fabrication and increases the tendency toward cracking during hot rolling,

particularly if traces of sodium are present. The two main advantages of manganese additions to magnesium-containing alloys are that 1) the precipitation of the magnesium phase is more general throughout the structure, and that 2) manganese allows lower magnesium content and ensures a greater degree of stability to the alloy (53).

#### 4.2.4. Copper and Magnesium

The main benefit when both copper and magnesium are added to aluminum is the increased strength possible following solution heat treatment and quenching. In wrought materials, an increase in strength accompanied by high ductility occurs when aging at room temperature. By artificial aging, a further increase in strength, especially in yield strength, can be obtained but at a substantial sacrifice in tensile elongation. For both cast and wrought aluminum-copper alloys, as little as 0.5% magnesium is effective in changing aging characteristics. In wrought products, the effect of magnesium additions on strength can be maximized in artificially-aged materials by cold working prior to aging. In naturally-aged materials, however, the increase in strength due to magnesium additions can decrease with cold working (53).

#### 4.2.5. Manganese (Mn)

Manganese is a common impurity in primary aluminum, in which its concentration normally ranges from 5 to 50 ppm. The addition of manganese decreases resistivity of the alloy. Manganese increases strength either in solid solution or as a finely precipitated intermetallic phase. It has no adverse effect on corrosion resistance. As an addition, it is used to increase strength and to control the grain structure. The effect of manganese is to increase the recrystallization temperature and to promote the formation of fibrous structure upon hot working. As a dispersed precipitate, it is effective in slowing recovery and in preventing grain growth. The manganese precipitate increases the quench sensitivity of heat-treatable alloys (53).

#### 4.2.6. Scandium (Sc)

Scandium as an alloying element in aluminum has grown in interest in recent years. When scandium is introduced into an aluminum alloy, it increases the recrystallization temperature, increases the tensile strength, refines grain size, and helps in the reduction/elimination of hot cracking in welds. Scandium offers many benefits, but, because of its rarity, the cost of scandium-containing alloys is very sensitive to demand (1) (53).

#### 4.2.7. Silicon (Si)

Silicon, after iron, occurs as the highest impurity level in commercial aluminum containing electrolytes: 0.01% to 0.15%. In wrought alloys, silicon is used with magnesium at levels up to 1.5% to produce Mg<sub>2</sub>Si in the 6xxx series of

<sup>5</sup> Percentages in Section 4.2 are by weight unless otherwise specified

heat-treatable alloys. High-purity aluminum-silicon alloys – up to 3% silicon, the most critical range being 0.17% to 0.8% silicon – are brittle at high temperatures. However, additions of silicon, 0.5 to 4.0%, reduce the cracking tendency of aluminum-copper-magnesium alloys. Small amounts of magnesium added to any silicon-containing alloy will render it heat-treatable, but the opposite is not true because excess magnesium, over that required forming  $Mg_2Si$ , sharply reduces the solid solubility of this compound (53).

#### 4.2.8. Silver (Ag)

Silver has an extremely high solid solubility in aluminum, up to 55%. Due to cost, no binary aluminum-silver alloys are in widespread use. Small additions – 0.1% to 0.6% – however, are effective in improving the strength and stress corrosion resistance of aluminum-zinc-magnesium alloys (53).

#### 4.2.9. Tin (Sn)

Tin is used as an alloying addition to aluminum for both wrought and cast alloys. In wrought alloys, its concentration commonly can be from a minimum of 0.03% to much higher, and in cast alloys, as much as 25%. The addition of small amounts – 0.05% – of tin greatly increase the response of aluminum-copper alloys to artificial aging following a solution heat treatment. This results in an increase in strength and an improvement in corrosion resistance; however, higher concentrations of tin cause hot cracking. As little as 0.01% of tin in commercial-grade aluminum will cause surface darkening on annealed products and increase the susceptibility to corrosion due to migration of tin to the surface. This effect can be reduced by small additions (e.g., 0.2%) of copper. Aluminum-zinc alloys with small additions of tin are used as sacrificial anodes in seawater. The aluminum-tin alloys with additions of other metals such as copper, nickel, and silicon are used where bearings are required to withstand high speeds, loads, and temperatures. The copper, nickel, and silicon additions improve load-carrying capacity and wear resistance (53).

#### 4.2.10. Titanium (Ti)

Titanium is found in commercial-purity aluminum in amounts of 10 to 100 ppm. Titanium depresses the electrical conductivity of aluminum, but its effect can be reduced by the addition of boron. Titanium is used primarily as a grain refiner of aluminum alloy castings and ingots<sup>†</sup>. When titanium is used alone, the effect of maintaining the molten state decreases with time and with remelting. The grain-refining effect is enhanced if boron is present in the melt or if it is added as a master alloy containing boron. Titanium is a common addition to weld filler wire; it refines the weld structure and prevents weld cracking (53).

#### 4.2.11. Zinc (Zn)

The aluminum-zinc alloys have been known for many years, but hot cracking of the casting alloys and the susceptibility to stress-corrosion cracking of the wrought alloys have limited their use. Aluminum-zinc alloys containing other elements offer the highest combination of tensile properties in wrought aluminum alloys. Efforts to overcome the aforementioned limitations have been successful, and these aluminum-zinc alloys are being used commercially to an increasing extent. The addition of magnesium to the aluminum-zinc alloys develops the strength potential of this alloy system, especially in the range of 3% to 7.5% zinc. Magnesium and zinc form  $MgZn_2$ , which produces a far greater response to heat treatment than occurs in the binary aluminum-zinc system. The strength of the wrought aluminum-zinc alloys also is substantially improved by the addition of magnesium. The addition of magnesium in excess – 100% and 200% by weight of that required to form  $MgZn_2$  – further increases tensile strength. However, increasing additions of both zinc and magnesium decrease the overall corrosion resistance of aluminum to the extent that close control over the microstructure, heat treatment, and composition are often necessary to maintain adequate resistance to stress corrosion and to exfoliation attack. Depending on the alloy, stress corrosion is controlled by some or all of the following: 1) overaging, 2) controlling the cooling rate after solution treatment, 3) maintaining a non-recrystallized structure through the use of additions such as zirconium, copper or chromium, 4) and adjusting the zinc-magnesium ratio closer to 3:1. The addition of copper to the aluminum-zinc-magnesium system, together with small but important amounts of chromium and manganese, results in the highest-strength aluminum-base alloys commercially available. In this alloy system, zinc and magnesium control the aging process. The effect of copper is to increase the aging rate by increasing the degree of supersaturation and perhaps through nucleation of the  $CuMgAl_2$  phase. Copper also increases quench sensitivity upon heat treatment. In general, copper reduces the resistance to general corrosion of aluminum-zinc-magnesium alloys, but increases the resistance to stress corrosion. The minor alloy additions, such as chromium and zirconium, have a marked effect on mechanical properties and corrosion resistance (53).

#### 4.2.12. Zirconium (Zr)

Zirconium additions – in the range of 0.1% to 0.3% – are used to form a fine precipitate of intermetallic particles that inhibit recovery and recrystallization. An increasing number of alloys, particularly in the aluminum-zinc-magnesium family, use zirconium additions to increase the recrystallization temperature and to control the grain structure in wrought products. Zirconium additions leave this family of alloys less quench-sensitive than similar chromium additions (53).

**Table 2. Summary of Alloying Elements**

<b>Elements</b>	<b>Added Amount (By Weight)</b>	<b>Effects</b>	<b>Results</b>	<b>Drawbacks</b>
<b>Chromium (Cr)</b>	0.35%	<ul style="list-style-type: none"> <li>Forms finely dispersed phases in wrought products</li> </ul>	<ul style="list-style-type: none"> <li>Prevents grain growth and recrystallization</li> <li>Reduces stress corrosion susceptibility</li> <li>Improves toughness and strength</li> </ul>	<ul style="list-style-type: none"> <li>In heat-treatable alloys, increases the quench sensitivity</li> </ul>
<b>Copper (Cu)</b>	2% - 10%		<ul style="list-style-type: none"> <li>Increase strength and hardness</li> </ul>	<ul style="list-style-type: none"> <li>Decreases elongation</li> </ul>
<b>Magnesium (Mg)</b>	≤ 5.5%		<ul style="list-style-type: none"> <li>Increase in strength without decreasing the ductility</li> <li>Produces good corrosion resistance and weldability</li> </ul>	<ul style="list-style-type: none"> <li>Causes susceptibility to intergranular cracking and stress corrosion</li> </ul>
<b>Manganese (Mn)</b>	0.3% - 1.5%	<ul style="list-style-type: none"> <li>Decreases resistivity of the alloy</li> </ul>	<ul style="list-style-type: none"> <li>Increases strength and controls grain structure</li> <li>No adverse effect on corrosion resistance</li> </ul>	<ul style="list-style-type: none"> <li>Increases the quench sensitivity of heat-treatable alloys</li> </ul>
<b>Scandium (Sc)</b>		<ul style="list-style-type: none"> <li>Increases the recrystallization temperature</li> <li>Refines grain size</li> </ul>	<ul style="list-style-type: none"> <li>Increases the tensile strength</li> <li>Helps in the reduction / elimination of hot cracking in welds</li> </ul>	
<b>Silicon (Si)</b>	0.5% - 4%		<ul style="list-style-type: none"> <li>Reduces the cracking tendency of Al-Cu-Mg alloys</li> </ul>	<ul style="list-style-type: none"> <li>Ranges of 0.17%-0.8% cause brittleness at high temperatures</li> </ul>
<b>Silver (Ag)</b>	0.1% - 0.6%		<ul style="list-style-type: none"> <li>Increases the strength and stress corrosion resistance of Al-Zn-Mg alloys</li> </ul>	
<b>Tin (Sn)</b>	0.03% - 25%	<ul style="list-style-type: none"> <li>Increases the response of Al-Cu alloys to artificial aging</li> </ul>	<ul style="list-style-type: none"> <li>Increases strength and improves corrosion resistance</li> </ul>	<ul style="list-style-type: none"> <li>Can cause hot cracking</li> </ul>
<b>Titanium (Ti)</b>		<ul style="list-style-type: none"> <li>Used primarily as a grain refiner</li> <li>Refines weld structure</li> </ul>	<ul style="list-style-type: none"> <li>Depresses the electrical conductivity of Al</li> <li>Prevents weld cracking</li> </ul>	
<b>Zinc (Zn)</b>	3% - 7.5%		<ul style="list-style-type: none"> <li>Along with other additions, Al-Zn alloys offer the highest combination tensile properties in wrought alloys</li> </ul>	<ul style="list-style-type: none"> <li>Causes hot cracking</li> <li>Susceptibility to stress-corrosion cracking</li> </ul>
<b>Zirconium (Zr)</b>	0.1%-0.3%	<ul style="list-style-type: none"> <li>Controls grain structure</li> <li>Forms a fine intermetallic precipitate to inhibit recrystallization</li> </ul>	<ul style="list-style-type: none"> <li>Reduces quench-sensitivity</li> </ul>	

#### 4.2.13. Summary of Alloying Elements

Table 2 provides a summary of the alloying elements and the effects produced by adding each to an alloy.

### 4.3. Comparison of Alloys

#### 4.3.1. Alloy and Temper Designations

The alloy designation system used in the United States is covered by the American National Standards Institute (ANSI) standard H35.1, Alloy and Temper Designation Systems for Aluminum<sup>6</sup> (16). This standard names the Aluminum Association as the registrar for the designation and composition of aluminum alloys within the United States; however, this designation system is recognized throughout the world<sup>7</sup> as well. There are two designation systems; the first is for wrought alloys, and the second is for cast alloys.

##### 4.3.1.1. Wrought Alloy Designation System

The wrought aluminum alloy designation system uses four digits to indicate the composition followed by a hyphen, a letter and a number of digits to indicate the temper of the alloy.

The alloys are separated into series indicated by the first digit of the alloy number. These series are groups of alloys which have their major alloying element in common.

The 1xxx series corresponds to “pure” ( $\geq 99\%$ ) aluminum. The 10xx alloys are unalloyed compositions with natural impurity limits. The last two digits indicate the minimum aluminum level corresponding to the digits xx in 99.xx%. For other variations of the second digit (assigned consecutively), the second digit indicates special control of the quantity of one or more impurities. The 1xxx series alloys are non-heat-treatable. Due to their purity (and, thus,

---

<sup>6</sup> This designation system has also been accepted by the American Society for Testing and Materials (ASTM) (49).

<sup>7</sup> Additional alloy designation systems are used throughout the world including: Önorm (Austria), Canadian Standards Association (CSA) (Canada), Normes Françaises (France), Deutsche Industrie-Norm (Germany), Werkstoff-Nr (Germany), British Standard (Great Britain), Unificazione Nazionale Italiana (Italy), Una Norma Español (Spain), Verein Schweizerischer Maschinenindustrieller (Switzerland), and the International Organization for Standardization (International). *Aluminum Standards and Data, 2009* (5) provides a table (Table 1-2) of comparable designations in different systems. This guide uses the Aluminum Association designation system unless noted otherwise.

high electrical conductivity) and low strength, they are typically used in the electrical and chemical industries.

For the 2xxx through 8xxx series, the second digit indicates the alloy modification<sup>8</sup> with zero indicating the original alloy. The remaining two digits further differentiate the various alloys.

The 2xxx series includes alloys with copper as the principal alloying element. See Section 4.2.2 for a general description of the affect of adding copper. These alloys are able to be heat-treated, which produces high strength. Their corrosion resistance, however, is relatively poor, and 2xxx series alloys clad with pure aluminum or a more resistant alloy are common (see Section 5.1.4). They are widely used in the aircraft industry.

The 3xxx series includes alloys with manganese as the principal alloying element. See Section 4.2.5 for a general description of the affect of adding manganese. These alloys are non-heat treatable. They have moderate strength and have high workability. They are used to produce architectural products.

The 4xxx series includes alloys with silicon as the principal alloying element. See Section 4.2.7 for a description of the affect of adding silicon. These alloys vary in their heat-treatability. Due to the reduction in the melting point, they are used in the production of welding rods and brazing sheets.

The 5xxx series includes alloys with magnesium as the principal alloying element. See Section 4.2.3 for a description of the affect of adding magnesium. These alloys are non-heat-treatable. They are used in the maritime industry primarily due to their increased corrosion resistance but also due to good weldability. The 5xxx series plates that are utilized in marine environments are specified in ASTM B928-04 (20). Table 3 lists some mechanical properties of common 5xxx series marine aluminum alloys.

The 6xxx series includes alloys with magnesium and silicon as the principal alloying elements. See Sections 4.2.3 and 4.2.7 for a general description of the affect of adding these elements. These alloys are able to be heat-treated. They are medium to high strength alloys with good corrosion resistance. They are used for a wide variety of products. Table 3 lists some mechanical properties of common 6xxx series marine aluminum alloys.

---

<sup>8</sup> Explicit rules exist to differentiate an alloy modification from a new alloy.

**Table 3. Mechanical Properties of Common Marine Aluminum Alloys (115) (53)**

Alloy and Temper	Thickness Range		Ultimate Strength <sup>4</sup>		Yield Strength <sup>4</sup> (0.2% Offset)		Elastic Modulus		Density		As-Welded Typical Ultimate Strength		As-Welded Minimum Yield Strength	
	in	mm	ksi	MPa	ksi	MPa	ksi x10 <sup>3</sup>	GPa	lbs/in <sup>3</sup>	g/cm <sup>3</sup>	ksi	MPa	ksi	MPa
5052-H32 (S&P)	All	All	31.0	215	23.0	160	10.2	70.3	0.097	2.68	28	193	13	90
5052-H34 (S&P)	All	All	34.0	235	26.0	180	10.2	70.3	0.097	2.68				
5059-H111 (E) <sup>1</sup>	0.114-1.968	3.0-50	47.7	329	23.2	160			0.096	2.66				
5059-H116 (S&P) <sup>1</sup>	0.114-0.787	3.0-20	53.5	438	39.1	270			0.096	2.66				
5059-H116 (P) <sup>1</sup>	0.788-1.968	20.1-50	52.1	359	37.6	259								
5059-H321 (P) <sup>1</sup>	0.114-0.787	3.0-20	53.5	369	39.1	270								
5059-H321 (S&P) <sup>1</sup>	0.788-1.968	20.1-50	52.1	359	37.6	259								
5083-H111 (E)	<=5.0	<=130	40.0	275	24.0	165	10.3	71	0.096	2.66	43	296	24	165
5083-H116 (S&P)	0.188-1.5	4.0-40	44.0	305	31.0	215	10.3	71	0.096	2.66				
5083-H116 (P)	1.5-3.0	40-80	41.0	286	29.0	200	10.3	71	0.096	2.66				
5083-H321 (S&P) <sup>1</sup>	0.063-1.5	1.6-38	44.0	303	31.0	214			0.096	2.66				
5083-H321 (P) <sup>1</sup>	1.501-3.0	38.1-76.5	41.0	283	29.0	200			0.096	2.66				
5086-H111 (E)	<=5.0	<=130	36.0	250	21.0	145	10.3	71	0.096	2.66	38	262	17	117
5086-H112 (E) <sup>2</sup>			45.0	310	27.6	190	10.2	70	0.096	2.66				
5383-H116 (P) <sup>2</sup>	<0.79	<20	44.2	305	31.2	215	10.2	70	0.096	2.66				
5454-H111 (E)	<=5.0	<=130	33.0	230	19.0	130	10.3	71	0.097	2.69	34	234	16	110
5454-H32 (S&P)	0.02-2.0	0.5-50	36.0	250	26.0	180	10.3	71	0.097	2.69				
5456-H116 (S&P)	0.188-1.25	4.0-12.5	46.0	315	33.0	230	10.3	71	0.096	2.66	46	317	26	179
5456-H116 (P)	1.251-1.5	31.8-38.1	44.0	305	31.0	215	10.3	71	0.096	2.66				
5456-H116 (P)	1.501-3.0	40.01-80	41.0	285	29.0	200	10.3	71	0.096	2.66				
5456-H321 (S&P) <sup>1</sup>	0.188-0.499		46.0 / 59.0		33.0 / 46.0				0.096	2.66				
6005A-T61 (E) <sup>3</sup>			38.0	260	35.0	240	10.0	68.9	0.098	2.70				
6061-T6 (E)	All	All	38.0	260	35.0	240	10.0	68.9	0.098	2.70			18	124
6063-T6 (E)	All	All	30.0	205	25.0	170	10.0	68.9	0.097	2.70			12	83
6082-T6 (E) <sup>1</sup>	All	All	45.0	310	38.0	262			0.098	2.70				

Notes: (E) - Extrusions, (S&P) - Sheet and Plate, (P) Plate

1) ABS, Rules for Materials and Welding, 2006

2) ALCAN, 2004

3) Data supplied by Tower Extrusions, Olney, Texas

4) Where two values are given, the first is the minimum allowable, and the second is the maximum allowable

**Table 4. Wrought Aluminum Alloy Series General Properties (53)**

Series	1xxx	2xxx	3xxx	4xxx	5xxx	6xxx	7xxx	8xxx
Primary Alloying Element	No Major additions, "pure"	Copper	Manganese	Silicon	Magnesium	Magnesium & Silicon	Zinc	Varies
Heat Treatable	No	Yes	No	Varies	No	Yes	Yes	Varies
General Corrosion Resistance <sup>1</sup>	A	C-E	A	B-C	A-B	A-C	B-E	A
SCC <sup>2</sup>	A	A-D	A	B	A	A-B	B-C	A
Workability (Cold)	A-C	B-D	A-C		A-C	A-D	D	A
Weldability <sup>3</sup>	A	A-D	A	B-D	A-C	A-D	B-D	A
Machinability <sup>4</sup>	D-E	A-D	C-E	B	C-E	B-D	B-D	D
Yield Strength (MPa)	28-165	69-414	40-250	315	41-407	50-379	83-545	95
Ultimate Strength (MPa)	76-186	172-469	110-285	380	124-434	90-400	193-594	160

Notes:

- 1) Ratings A-E are relative ratings in decreasing order of merit, based on exposure to sodium chloride solution by intermittent spraying or immersion. Alloys with A & B ratings can be used in industrial and seacoast atmospheres without protection. Alloys with C, D, & E ratings generally should be protected at least on faying surfaces.
- 2) Stress-corrosion cracking ratings are based on service experience and on laboratory tests of specimens exposed to the 3.5% sodium chloride alternate immersion. A=No known failure in service or in laboratory tests. B=No known instance of failure in service; limited failures in laboratory tests of short transverse specimens. C= Service failures with sustained tension stress acting in short transverse direction relative to grain structure; limited failures in laboratory tests of long transverse specimens. D=Limited service failures with sustained longitudinal or long transverse stress.
- 3) Ratings A-D for weldability and brazeability<sup>†</sup> are relative ratings defined as follows: A=Generally weldable by all commercial procedures and methods. B=Weldable with special techniques or for specific applications: requires preliminary trials or testing to develop welding procedure and weld performance. C=Limited weldability because of crack sensitivity or loss in resistance to corrosion and mechanical properties. D= No commonly used welding methods have been developed.
- 4) Ratings A-D for workability (cold), and A-E for machinability, are relative ratings in decreasing order of merit.

The 7xxx series includes alloys with zinc as the principal alloying element. See Section 4.2.11 for a general description of the affect of adding zinc. These alloys are able to be heat-treated. They are used in the aircraft industry and for other uses requiring high strength alloys.

The 8xxx series includes miscellaneous alloys; currently, there are alloys with iron, nickel, tin and/or lithium as alloying element. Their ability to be heat-treated varies by alloy.

The 9xxx series is currently unused but is reserved for future use.

Table 4 summarizes the general properties of the different series of alloys.

#### 4.3.1.2. Cast Alloy Designation System

The cast aluminum alloy designation system uses three digits followed by a decimal and an additional digit to indicate the composition. The cast alloy designation uses the same hyphen, letter, and number of digits to indicate the temper as in the wrought alloy designation system.

As in the wrought alloy designation system, the alloys are separated into groups by the first digit of the alloy number, and the groups were formed by grouping the alloys with the same principal alloying element. However, the first digit in the cast and wrought designation systems do not always indicate the same principal alloying element. A capital letter prefixing the designation number indicates a modification of an existing alloy; the letters are used in

alphabetical order with I, O, Q, and X being omitted. The letter X as a prefix indicates an experimental alloy; it is dropped when the alloy is no longer experimental.

The 1xx.x group corresponds to “pure” ( $\geq 99\%$ ) aluminum. The second and third digits in the 1xx.x group indicate the minimum aluminum level corresponding to the digits xx in 99.xx%. The last digit indicates whether the alloy is a casting (.0) or an ingot (.1 or .2).

For the 2xx.x through 9xx.x groups, the second and third digits have no significance except to differentiate the different alloys.

The 2xx.x group includes alloys with copper as the principal alloying element. See Section 4.2.2 for a general description of the affect of adding copper.

The 3xx.x group includes alloys with silicon and additional copper and/or magnesium as the principal alloying element. See Sections 4.2.7, 4.2.2, and 4.2.3 for a general description of the affect of adding silicon, copper, and magnesium, respectively.

The 4xx.x group includes alloys with silicon as the principal alloying element. See Section 4.2.7 for a general description of the affect of adding silicon.

The 5xx.x group includes alloys with magnesium as the principal alloying element. See Section 4.2.3 for a general description of the affect of adding magnesium.

The 6xx.x group is currently unused but is reserved for future use.

The 7xx.x group includes alloys with zinc as the principal alloying element. See Section 4.2.11 for a general description of the affect of adding zinc.

The 8xx.x group includes alloys with tin as the principal alloying element. See Section 4.2.9 for a general description of the affect of adding tin.

The 9xx.x group includes miscellaneous alloys with varying elements as the primary alloying element.

#### 4.3.1.3. Temper Designation System

The wrought and cast alloy designation systems employ a common method of indicating the temper of the alloy. A hyphen follows the alloy composition designation (e.g., xxxx for wrought alloys or xxx.x for cast alloys), followed by a letter and a series of digits. Table 6 summarizes the tempers.

The F designation indicates the material is “as fabricated,” which may include cold working, hot working or a casting process. The O designation indicates that the material has been annealed.

**Table 5. Cast Aluminum Alloy Series General Properties (53)**

Group	1xx.x	2xx.x	3xx.x	4xx.x	5xx.x	6xx.x	7xx.x	8xx.x	9xx.x
<b>Primary Alloying Element</b>	No major additions, "pure"	Copper	Silicon with Copper and/or Magnesium	Silicon	Magnesium	Currently Unused	Zinc	Tin	Varies
<b>Heat Treatable</b>	No	Yes	Yes	Yes	No		Yes	No	No
<b>Corrosion Resistance<sup>1</sup></b>		3-4	2-4	2-4	1-2		2-3	3	
<b>Weldability<sup>2</sup></b>		2-4	1-3	1-4	3-5		3-4	4	
<b>Machinability<sup>3</sup></b>		1-3	3-4	3-5	1-2		1	1	
<b>Yield Strength (MPa)</b>	40	97-414	83-296	55-145	83-186		103-262	76-159	
<b>Ultimate Strength (MPa)</b>	70	145-469	159-393	131-228	138-331		240-330	138-221	

Notes:

- 1) Relative rating based on resistance of alloy in standard salt spray test in decreasing merit from 1 to 5.
- 2) Relative rating based on ability of material to be fusion welded with filler rod of same alloy in decreasing merit from 1 to 5.
- 3) Composite rating based on ease of cutting, chip characteristics, quality of finish, and tool life in decreasing merit from 1 to 5.



H indicates that the material is strain hardened. The first digit indicates: strain hardened only (1), strain hardened and partially annealed (2), or strain hardened and stabilized (3). The second digit (x) indicates the final degree of strain hardening ranging from 0 to 8. Tempers between 0 (annealed) and 8 (full-hard) are designated by the numbers 1

through 7. A number 4 (which is halfway between 0 and 8) designation is considered half-hard; number 2 is considered quarter-hard; and the number 6 is three-quarter hard. When the number is odd, the limits of ultimate strength are exactly halfway between those of the even numbered tempers.

**Table 6. Aluminum Alloy Temper Designations (17)**

<b>Temper Designation</b>	<b>Description</b>
<b>F</b>	As Fabricated by cold working, hot working or casting process
<b>O</b>	Annealed
<b>H</b>	Strain-Hardened (Wrought Products Only)
<b>H1</b>	Strain-Hardened Only
<b>H111</b>	Applies to alloys which are strain-hardened less than the amount required for a controlled H11 temper
<b>H112</b>	Applies to alloys that acquire some temper from shaping processes which do not have special control over the amount of strain-hardening or thermal treatment, but for which there are mechanical property limits
<b>H116</b>	Applies to 5000-series alloys, Mg content min. 4%
<b>H2</b>	Strain-Hardened and Partially Annealed
<b>H3</b>	Strain Hardened and Stabilized
<b>H32</b>	Strain hardened to be quarter-hard and stabilized
<b>H321</b>	Applies to alloys which are strain-hardened less than the amount required for a controlled H32 temper
<b>H34</b>	Strain hardened to be half-hard and stabilized
<b>W</b>	Solution Heat-Treated <sup>1</sup>
<b>T</b>	Solution Heat-Treated <sup>2</sup>
<b>T1</b>	Cooled From an Elevated Temperature Shaping Process and Naturally Aged to a Substantially Stable Condition
<b>T2</b>	Cooled From an Elevated Temperature Shaping Process, Cold-Worked, and Naturally Aged to a Substantially Stable Condition
<b>T3</b>	Solution Heat Treated, Cold Worked, and Naturally Aged to a Substantially Stable Condition
<b>T4</b>	Solution Heat Treated and Naturally Aged to a Substantially Stable Condition
<b>T5</b>	Cooled From an Elevated Temperature Shaping Process and Artificially Aged
<b>T6</b>	Solution Heat Treated and Artificially Aged
<b>T61</b>	Applies to alloys which are solution heat treated, quenched in boiling water, (to minimize residual stresses), and artificially aged
<b>T7</b>	Solution Heat Treated and Overaged or Stabilized
<b>T8</b>	Solution Heat Treated, Cold Worked, and Artificially Aged
<b>T9</b>	Solution Heat Treated, Artificially Aged, and Cold Worked
<b>T10</b>	Cooled From an Elevated Temperature Shaping Process, Cold Worked, and Artificially Aged
<b>Tx51</b>	Stress relieved by stretching; products receive no further straightening after stretching
<b>Tx510</b>	Extruded products receive no further straightening after stretching
<b>Tx511</b>	Extruded products receive minor straightening after stretching to comply with standard tolerances
<b>Tx52</b>	Stress relieved by compressing
<b>Tx54</b>	Stress relieved by combined stretching and compressing, applying to die forgings

Notes:

1. The W temper is an unstable temper, which is used for alloys having strength that changes over months or years at room temperature after solution heat treatment (17).
2. The T temper designation is used for alloys that are stable within a few weeks of solution heat treatment (17).

## 5. Component Manufacturing Processes

There are multiple methods by which aluminum components are manufactured. The following sections describe these methods, their advantages and disadvantages, and any considerations for designing components which are manufactured using the method.

### 5.1. Rolling

Rolling is used to manufacture aluminum plate and sheet. Sheet refers to flat stock that has a thickness greater than 0.006 in up to 0.25 in. Plate differs from sheet in that it has a thickness typically greater than 0.25 in.<sup>9</sup>

#### 5.1.1. Rolling Process

Rolling slabs are produced in a continuous vertical casting process. These slabs are then cut into individual slabs, which are skimmed on both faces and heated prior to entering the hot mill. The hot mill uses hot-rolling to produce plate. Sheet is produced by cold reduction (several passes of cold rolling with annealing between each pass) of plate.

#### 5.1.2. Plate Products

Plate is typically provided in the ‘F’ condition (Hot Rolled) or in the ‘O’ (Annealed) condition, if it has been annealed after the hot-rolling phase. Plate composed of heat-treatable alloys from the 2xxx, 6xxx, or 7xxx series can be supplied 1) in the T4 temper if it is naturally aged at room temperature or 2) in the T6 temper if it has been quenched and then artificially aged (56).

#### 5.1.3. Sheet Products

Common sheet thicknesses include 0.025, 0.032, 0.040, 0.050, 0.063, 0.071, 0.080, 0.090, 0.100, 0.125, 0.160 and 0.190 in. (79). In the case of non-heat treatable alloys (1xxx, 3xxx, and 5xxx series), sheet can be provided in a stated *temper* (e.g., ‘quarter hard’, ‘half hard’, etc.). Alternatively, if the sheet is given a precise reduction after the last annealing phase, it is considered *temper rolled*, or if it is annealed after the last rolling pass, it is considered *temper annealed*. In the case of heat-treatable alloys (2xxx, 6xxx, and 7xxx series), it is typically provided in a fully heat-treated condition (e.g., T6) (56).

#### 5.1.4. Specialty Flat Products

Sheet produced in 2xxx and 7xxx series alloys can be produced clad in pure aluminum (2xxx series) or pure aluminum with 1% Zinc (7xxx series) in order to improve the corrosion resistance of the sheet. A thin layer of

cladding material is added to each face prior to hot-rolling and is reduced along with the core material (56).

Treadplate incorporates the inclusion of an anti-slip pattern, which is rolled into the surface. It is commonly available in the 6xxx series alloys with a T6 temper (56).

Profile sheeting – available in 3xxx series alloys – is rolled into a profile, and is typically used for siding in the building construction industry (56).

Embossed sheeting includes a random pattern, which roughens the surface and reduces glare (56).

Cold-rolling can also be used to form profile sections – as is common with steel – however, the extrusion<sup>†</sup> process (see Section 5.3) is far more common for this purpose, except when beyond the limits of extruding e.g., when the wall thickness is exceedingly thin (~1 mm) (56).

#### 5.1.5. Constraints / Considerations

Although sheet and plate can be produced in nearly any desired thickness, consideration should be made to use commonly available thicknesses.

The thickness of plate and sheet can vary in general as well as across the width of the sheet. Equations (3) and (4) provide an estimate of the tolerance (56):

Plate:

$$\delta t = \pm(0.000014wt + 0.3)\text{mm} \quad (3)$$

Sheet:

$$\delta t = \pm(0.11\sqrt{t} + 0.00004w - 0.06)\text{mm} \quad (4)$$

Where:

$$\begin{aligned} w &= \text{the plate/sheet width } (w \geq 1000 \text{ mm}) \\ t &= \text{the nominal thickness } (1 \leq t \leq 30 \text{ mm}) \end{aligned}$$

## 5.2. Casting

The process of casting aluminum is initiated by heating the aluminum to a liquid state and then pouring it into a mold which contains a hollow cavity of the desired shape; finally, the material is allowed to solidify and cool, and the cast item is removed. Casting is most often used for making complex shapes that would be otherwise difficult or uneconomical to make by other methods (53).

Examples of aluminum casting in high speed aluminum vessels include water jet inlets and steering buckets.

<sup>9</sup> The word *shate* is sometimes used to describe flat products which fall on the border line between *plate* and *sheet* (56).

### 5.2.1. Casting Processes

Castings can be classified into two categories: non-expendable mold castings and expendable mold castings. Non-expendable mold castings do not require the mold to be reformed after each production cycle and are also able to form cast products with improved repeatability. Examples of non-expendable mold castings are: die casting, permanent mold casting, centrifugal casting, continuous casting, and semisolid-metal casting. Expendable mold castings use temporary or non-reusable molds. Examples of expendable mold castings are: sand casting, evaporative pattern casting (EPC), shell molding, plaster casting, and investment casting. The three primary methods used to produce aluminum castings (and the methods discussed herein) are permanent mold, die, and sand casting (53).

#### 5.2.1.1. Permanent Mold Casting

Permanent mold casting, the most common casting process, uses gravity to fill the mold; however, gas pressure or a vacuum are also commonly used. Molds for the casting process consist of two halves, usually formed from a metal with a high resistance to erosion and thermal fatigue. The mold is preheated prior to the first casting cycle, and then used continuously in order to maintain a uniform temperature for each casting cycle. The gravity casting process requires the metal to be poured at the lowest practical temperature in order to minimize cracks and porosity (53).

A variation on the typical gravity casting process, called *slush casting*, produces hollow castings. To do this, the material is poured into the mold and allowed to cool until a shell of material forms in the mold. The remaining liquid is then poured out to leave a hollow shell. This results in a cast that has good surface detail but with varying wall thickness (53).

Low-pressure permanent mold (LPPM) casting uses a gas at low pressure to push the molten metal into the mold cavity. The pressure on top of the pool of liquid forces the molten metal up a refractory pouring tube and finally into the bottom of the mold. No risers are required because the applied pressure forces the molten metal in to compensate for shrinkage. Vacuum casting is similar to LPPM casting, but a vacuum is used to fill the mold (53).

#### 5.2.1.2. Die Casting

Die casting is characterized by forcing the molten metal into the mold under high pressure. Depending on the type of metal being cast, a hot- or cold-chamber machine is used for molding. For aluminum castings, a cold-chamber machine is used because in the hot-chamber machine, the liquid aluminum picks up iron in the molten pool (53).

#### 5.2.1.3. Sand Casting

The sand casting process uses a mold that is formed around a pattern by ramming sand, mixed with the proper bonding agent, onto the pattern. The pattern is then removed, leaving a cavity in the shape of the casting to be made. Molten metal is poured into the mold, and once it has solidified, the mold is broken to remove the casting. Molds are made by bonding the sand using various agents such as clay, water, and oils or resins (53).

### 5.2.2. Inspection / Testing

#### 5.2.2.1. Permanent Mold Casting

Surface finishes range from 3.8 to 10  $\mu\text{m}$  (150 to 400  $\mu\text{in.}$ ). Typical linear tolerances are about  $\pm 10$  mm/m ( $\pm 0.01$  in./in.) with minimum wall thicknesses of about 3.6 mm (0.140 in.). Mechanical properties of permanent mold castings can be further improved with heat treatment (53).

#### 5.2.2.2. Die Casting

Aluminum alloys can have a surface finish as fine as 1.3  $\mu\text{m}$  (50  $\mu\text{in.}$ ), and they can be cast to basic linear tolerances of  $\pm 4$  mm/m ( $\pm 4$  mils/in.). With die casting, thinner walls (as thin as 1.0 mm for small parts) can be cast, as compared to sand and permanent mold casting. Rapid injection and rapid solidification under high pressure combine to produce a dense, fine grain surface structure, which results in excellent wear and fatigue properties (53).

#### 5.2.2.3. Sand Casting

Among its disadvantages sand casting offers low dimensional accuracy and poor surface finish; basic linear tolerances range from  $\pm 30$  mm/m,  $\pm 0.030$  in./in., and surface finishes of 7-13  $\mu\text{m}$ , or 250-500  $\mu\text{in.}$  A minimum wall thickness of 4 mm, 0.15 in., is normally required for aluminum sand castings (53).

### 5.2.3. Constraints / Considerations

#### 5.2.3.1. Permanent Mold Casting

The advantages of permanent mold casting are 1) the re-usability of the mold, 2) the good surface finish produced, and 3) the good dimensional accuracy. Permanent mold casting typical part sizes range from several ounces to 25 lbs, but much larger castings can be made when costs of tooling and casting equipment are justified by the quality required for the casting. The fast cooling rates created by using a metal mold results in a finer grain structure than sand casting. There are some drawbacks to using permanent mold casting, the main ones are: high tooling cost, limited to low-melting-point metals, and short mold life. The high tooling costs make this process uneconomical for small production runs; however, the tooling costs are cheaper than those for die casting. For lower melting point metals, such

as aluminum, the mold life is longer but thermal fatigue and erosion usually limit the life to 10,000 to 120,000 cycles (53).

#### 5.2.3.2. Die Casting

The casting equipment and the metal dies represent large capital costs, which tends to limit this process to high volume production. Die casting offers the ability to maintain close tolerances and produce good surface finishes. Aluminum die casting is used for a typical part size of about 10 lbs, but castings weighing as much as 100 lbs are produced when the high tooling and casting-machine costs are justified. A large production volume is needed to offset the very high capital cost of die casting. The casting equipment, dies, and related components required are very costly compared to most other casting processes. Die castings are characterized by a very good surface finish and dimensional consistency but causes small amounts of porosity in the final casting. This prevents any heat treating or welding, because the heat causes the gas in the pores to expand, which causes micro-cracks inside the cast and exfoliation of the surface. Die casting can contain inserts, which are made of metal, to form holes in the molds, however the cores are restricted to simple shapes that permit straight-line removal (53).

#### 5.2.3.3. Sand Casting

A wide variety of alloys, shapes, and sizes can be sand cast. An advantage of sand casting is that it offers low cost and minimum equipment when a small number of casts are to be made. Sand castings require a long time to cool which results in low strength. The quality of a sand casting is determined to a large extent by foundry technique. Proper metal handling and gating practice is necessary for obtaining sound castings. Sand castings can become very complex, with varying wall thicknesses. These castings will only be sound if proper techniques are used (53).

### 5.3. Extruding

Although the extrusion process can be used with other metals e.g., brass and bronze, it has become a major method of forming aluminum components. This is due to several reasons (56):

- Aluminum can be extruded at a fairly low temperature.
- An unlimited number of shapes can be extruded with a wide range of complexity.
- Tool cost for a new profile is low compared to rolled shapes.
- The time required to retool an extrusion press is small compared to a roll change.
- Profiles can be produced which include very thin walls in comparison to the overall size of the profile.

#### 5.3.1. The Hot Extrusion Process

The hot extrusion process<sup>10</sup> consists of pressing a billet<sup>†</sup> of an aluminum alloy through a die<sup>†</sup>, which forms the desired shape for the component. Despite this brief definition, the hot extrusion process is complex, requiring profile design and material selection, die design and manufacturing, and material preparation.

##### 5.3.1.1. Profile Design / Material Selection

The design of an extrusion profile and selection of the material should factor in considerations and constraints from the manufacturing process. Extrusion profiles can include many features that may save manufacturing or assembly time, such as:

- A single extrusion may combine several previously separate parts (e.g., rolled shapes). This can reduce part count, reduce assembly and/or welding labor, produce better alignment of features, and produce stiffer parts. For example, a stiffener composed of a C-shape combined with an angle could be extruded as a single profile in aluminum.
- Additional machined details may be incorporated into the initial extruded profile to reduce manufacturing steps.
- A complex shape bent from sheet metal may be converted to an extruded part.
- Hinges, bolt and self-tapping<sup>†</sup> screw holes, snap-together joints, indexing marks, and weld lines can all be incorporated into the extruded profile. Although (to the knowledge of the authors) this has never been done previously, it may be possible to include an attachment rail for installing wireways, insulation, etc.
- A repeating pattern may allow the extrusion of interlocking deck or superstructure siding panels. These can include the stiffeners in addition to the plating. Extruding panels which include stiffeners both

---

<sup>10</sup> In addition to the hot extrusion process, there is also a cold extrusion process in which the material is pressed between two dies to form the desired shape. This process is used for small, typically cylindrically shaped items and is not associated with producing structural shapes. As such it is not covered in this guide. The *ASM Specialty Handbook* (53) provides a basic overview of this process.

Among all materials able to be hot extruded, there are multiple hot extrusion processes: non-lubricated, lubricated, and hydrostatic. The distinction between these methods is demonstrated in Figure 6 (pg. 265) of the Extrusion chapter of the *ASM Specialty Handbook* (53). The non-lubricated hot extrusion process is typically used among aluminum alloys; therefore, the description in this guide relates to this method.

reduces the amount of welding that must be done and simplifies the remaining welding since the weld line can occur between stiffeners which provides better access.

The 2xxx and 7xxx series alloys are difficult to hot extrude and the 5xxx and 6xxx series are generally easier to hot extrude (53).

However, it is necessary to factor in the constraints of the extrusion process (see Section 5.3.2).

### 5.3.1.2. Die† Design / Manufacturing

The components that comprise a die assembly vary based on the type of extrusion profile in use (solid†, hollow†, or semi-hollow†); however, for all profile types, the die may have multiple copies of the extrusion profile to enable multiple copies of the extrusion to be produced simultaneously (this is more common with small, simple extrusion profiles). The die assembly is typically machined from H-13 tool steel; although other materials are also in use (especially for the bolsters†, backers†, and die ring†). H-13 tool steel is utilized in the die assembly due to its abrasion resistance, high temperature strength, and high toughness (7).

A solid die assembly may include the following components: the die plate, a weld plate† or feeder plate†, a backer, a bolster, and a die ring. Figure 1 shows a typical solid extrusion die assembly. The die plate includes one or more copies of the extrusion profile through which the billet is pressed. The die plate may either be a flat plate type or pocket type; the pocket type allows the die designer to control the flow of material during the extrusion process (61). The alternative to a pocket type die plate is the use of a weld or feeder plate. The feeder plate may also be used to control the follow of material from one billet to the next. The backer has the same diameter as the die plate and includes a slightly larger cutout of the extrusion profile. It is placed immediately behind the backer in order to provide support to the die plate. The bolster serves the same function for the backer, but has a larger diameter. The die ring has the same diameter of the bolster and is cut out in the center to enclose the backer and die plate. Pins or bolts may be used to align the individual components (7).

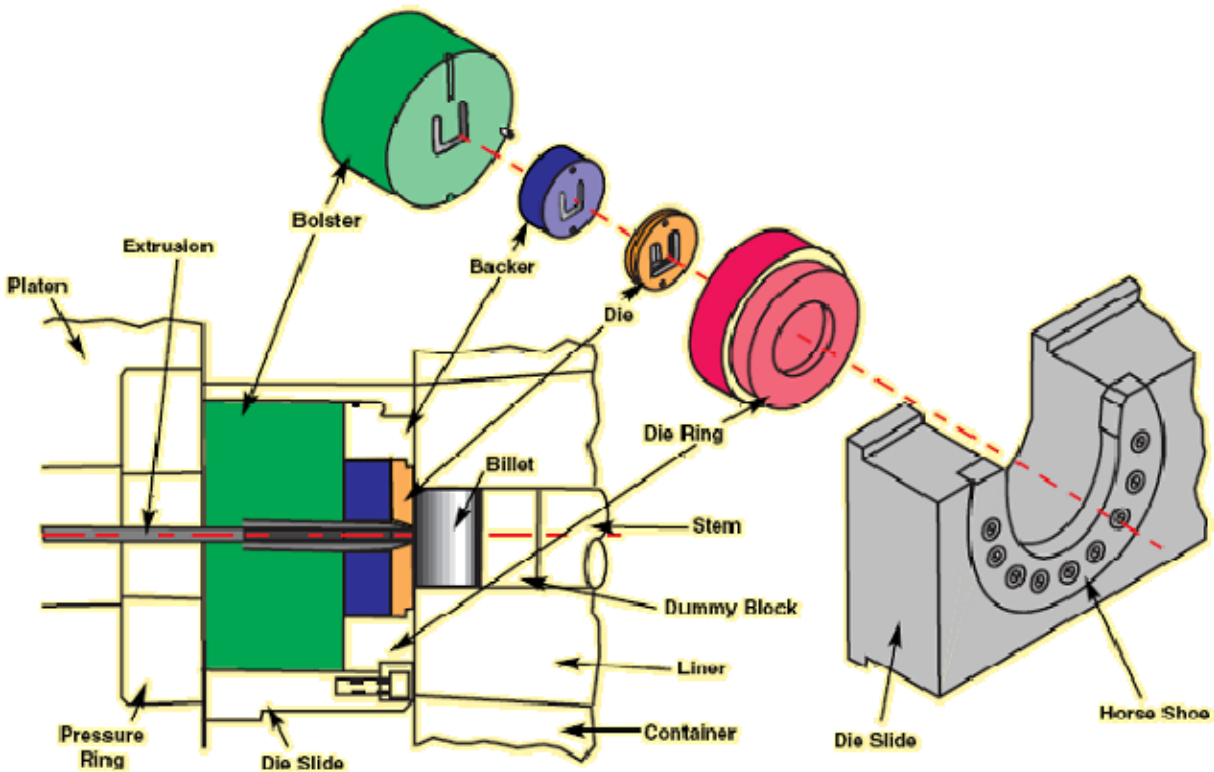

Figure 1. Solid Extrusion Die Assembly (7)

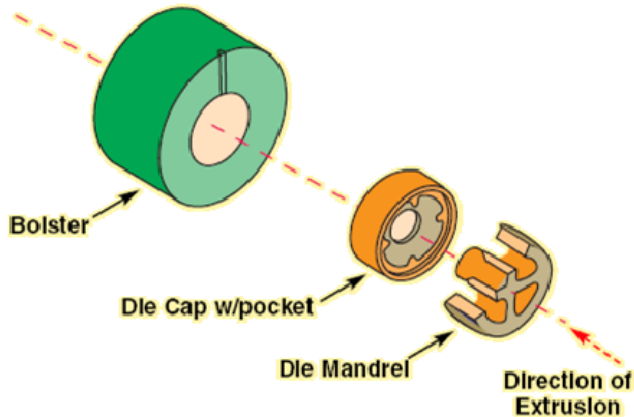

Figure 2. Porthole Hollow Die (7)

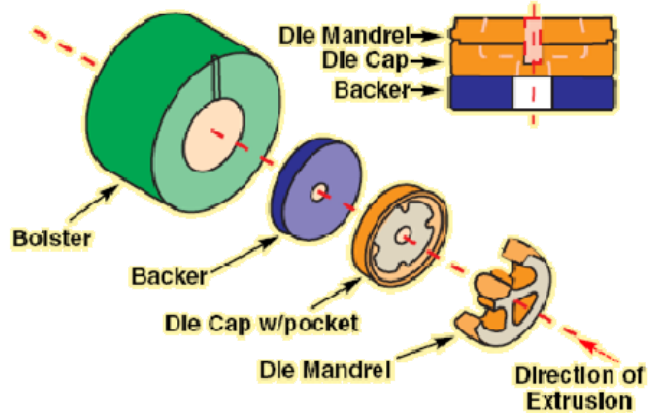

Figure 3. Pancake Hollow Die (7)

A hollow die assembly may include the following components: a die cap<sup>†</sup>, a die mandrel<sup>†</sup>, a backer, and a bolster. There are two types of die assemblies: a porthole die assembly (see Figure 2), which is larger and may include a backer, and a pancake die (see Figure 3), which is smaller but requires the use of a backer. The material first is pressed through the die mandrel which forms the interior features. The die mandrel includes one or more ports through which the material passes. The ports surround a center portion which is supported by webs, also referred to as, legs. The material then passes through the die cap which forms the exterior features (7).

A semi-hollow extrusion profile may be manufactured using a flat, recessed-pocket, weld-plate, or porthole die assembly, depending on the tongue ratio of the semi-enclosed shapes.

Die assembly components are typically designed and manufactured by the extrusion company or by a subcontractor<sup>11</sup>. The design process can include finite element analysis (FEA) or other computer simulations of the flow of the metal during the extrusion process. Various parameters of the extrusion process can be changed in the simulation to optimize the process (7).

#### 5.3.1.3. Material Preparation

Prior to being extruded, the alloy is cast into logs<sup>†</sup>, which are then cut into billets<sup>†</sup> to match the extrusion machinery in

<sup>11</sup> As the die design and manufacturing are not typically performed by the ship designer or shipyard, the details of these processes have not been described in this guide. For more details, see references (45), (62), (91), (92), (106), and (107).

use. Immediately before being loaded into the extrusion press, the billet<sup>†</sup> is preheated by gas-fired furnaces or electrical induction heaters in order to transition the material into a malleable state. The temperature required varies by alloy, but typically ranges from 300°C to 595°C (575°F to 1100°F) (53).

#### 5.3.2. Constraints / Considerations

There are several constraints and considerations which must be factored into the design process of a new extrusion profile, which are described in the following sections.

##### 5.3.2.1. Extrusion Type

The extrusion type is one of the most basic constraints. The simplest extrusion type is solid, which is the easiest to extrude. Semi-hollow and hollow extrusion profiles may not be able to be manufactured for a particular material or may affect the feasibility of certain tolerances.

##### 5.3.2.2. Billet Size

The billet size is also an important consideration. The required billet size is determined by finding the smallest circle that completely encloses the extrusion profile; this size is referred to as the circumscribing circle diameter (CCD). Larger sizes require more control to ensure proper flow of the material through the extrusion die. The size may also have an effect on production schedule because as billet size increases the number of available presses decreases.

#### 5.3.3. Optimization

The extrusion process can be a complex process depending on the extrusion profile and material. It may be necessary to adjust the die design e.g. to better facilitate material flow in a large profile. This can be done with FEA, but experience

with a particular profile or material should not be discounted.

#### 5.3.4. Post-Processing

Extruded products may undergo additional post processing steps after the extrusion process. This may include straightening to correct unavoidable twist or loss of straightness, machining in order to achieve non-extrudible features, and tempering of the final product.

#### 5.4. Drawing

Drawing is a metal working process in which a sheet metal blank is drawn into a forming die by the mechanical action of a punch press. Aluminum alloys typically undergo a process called deep drawing. A drawing is considered “deep” when the depth of the drawn part exceeds its diameter, done by redrawing the part through a series of dies. Stamping of sheet metal is a typical example of deep drawing. Common drawn products include bars, piping / tubing, and wires.

Punch presses are used for nearly all deep drawing; for experimental or very short runs, press brakes are used. Double action presses exert a hold-down force and a punch force on the sheet metal. Press speeds for aluminum are higher than press speeds for steel; medium strength aluminum alloys have a press speed of 40 to 100 ft/min for mild draws and less than 50 ft/min for deeper draws. High strength aluminum alloys draw speeds are typically 20 to 40 ft/min.

One of the limitations of drawing is the reduction in diameter that is possible in a single operation; for aluminum alloys, it is about the same as that of drawing quality steel. For deep-drawn, cylindrical shells, reductions in diameter are about 40% for the first draw, 20% for the second, and 15% for the third draw. The decrease in diameter reduction is due to strain hardening. For high-strength aluminum alloys, the permissible reduction is 30% for the first, 15% for the second, and 10% for the third draw.

When draws of large, thick shapes made from high strength aluminum alloys are desired, hot drawing is performed. Hot drawing is performed by heating the alloy to a temperature above the recrystallization point (typically, in the range of 350°F to 600°F), which lowers strength and increases ductility. The length of time the work piece can be held at temperature is controlled to avoid excessive grain growth in areas with little strain hardening (53).

#### 5.5. Machining

Aluminum alloys offer the ability to be machined quickly and cost-effectively. Machines used for machining steel can be used with aluminum; however, optimum machining conditions can only be achieved on machines designed for

machining aluminum alloys. The specific properties of aluminum alloys that are considered for machining are:

- Density – due to the low value for aluminum, high speeds of rotation and translation are permitted.
- Modulus of Elasticity – due to the low value, appropriate chucking and clamping arrangements are required to avoid deformation and distortion.
- Thermal Conductivity – due to the high value for aluminum, heat is readily dissipated in the aluminum alloy.
- Coefficient of Linear Expansion – due to the high value for aluminum, heating is undesirable if the criteria of dimensional stability are to be satisfied.

Factors that are considered for machining of aluminum alloys are:

- Cutting Force – the force required is far less than required for steel.
- Tooling – the geometry of tools must be specially designed for use with aluminum alloys.
- Cutting Speeds – all wrought alloys can be machined very rapidly.
- Rate of Advance – due to the low modulus of aluminum alloys, high rates of advance are not advisable.
- Lubrication – used to cool the heat generated by cutting.

##### 5.5.1. Common Machining Operations

- Turning<sup>†</sup> – an operation by which material is removed by forcing a single-point cutting tool against the surface of a rotating work piece. Typically, carried out on a lathe and can be of four different types: straight turning, taper turning, profiling, or external grooving.
- Boring<sup>†</sup> – a method to enlarge holes using a single-point cutting tool, it is used to achieve better accuracy of the diameter of a hole. Boring can also be used to cut a tapered hole.
- Broaching<sup>†</sup> – is a method of removing material using a toothed tool, called a broach. There are two types of broaching: linear broaching and rotary broaching. Linear broaches are the most common and are used in broaching machines.
- Drilling<sup>†</sup> – a cutting process that uses a drill bit to either create or enlarge a hole in a solid material.
- Reaming – is the process of creating an accurate size hole using a reamer. It is an alternative to drilling when dimensional accuracy is required.
- Single-Point Threading – an operation that uses a single-point tool to produce a thread form on a cylinder or cone. This process can create either internal or external threads, male or female.

- Tapping – is the process of producing a thread in a form. Unlike thread cutting, no chips are produced, as the material is moved during the forming process and not cut which results in the surface hardening and achieving a greater strain resistance.
- Milling – is the complex shaping of metal by removing material to form the final shape. It is generally done on a milling machine. The milling machine has a milling cutter that rotates about the spindle axis, like a drill, and a worktable that can move in two or more directions relative to the work piece.
- Grinding – is a process that uses an abrasive wheel to create fine finishes, very light cuts, or high precision forms. The wheel can be made up of various sizes and types of stones.
- Honing – is similar to grinding in which an abrasive stone is moved along a controlled path to produce a precision surface.



## 6. Vessel Construction

Section 5 describes the various methods of manufacturing aluminum structural components. The following section describes several types of joining methods that can be used for assembling those components in order to produce the vessel's structure. These include riveting, bolting, welding, and adhesives. Table 7 summarizes some of the advantages and disadvantages of using each method.

### 6.1. Riveting

Riveting is rarely found in ship construction today except for very lightweight applications. It was once the only way to build aluminum structures because welding technologies were not sufficiently advanced at the time. As riveting became less used, skilled riveters became more scarce; today, the majority of connections that were once made with rivets are made with mechanical fasteners. Therefore, this section has been provided for informational purposes.

#### 6.1.1. Advantages and Disadvantages

The main advantage of using rivets is the weight savings that can be achieved in the design process of the supporting structure. This is due to the fact that a riveted joint may be stronger than a welded joint as a result of the loss of strength from welding. The potential weight savings due to the reduction in supporting structure is diminished by the increase in the joint itself – typically, 15% for using a riveted joint versus 2.5% for the weight of welds (115).

Riveting is sometimes more desirable than welding because the riveting process can achieve a higher tolerance than welding since welding can cause distortion.

Riveting is generally no longer the preferred method of joining in ship construction because a rivet cannot be put in tensile loading and has poor fatigue characteristics in shear loading. Ninety percent of the fatigue failures in rivet joints occur in the outer holes, with the rest usually occurring as a result of fretting near one of the outer, most highly loaded holes. The following are guidelines from studies of riveted joints in structures (115):

- Variations in joint design are more significant than changes in the alloy used.
- Joints of high static strength do not necessarily have high fatigue strength.
- Fatigue strength of a joint increases with the number of fasteners used, but not in proportion to the static strength.
- In a multi-row lap joint, the edge rivets carry the highest load; therefore, as the number of rivets is increased, the fatigue strength is not increased proportionately.

- The greatest fatigue strength is obtained with large diameter rivets placed close together and close to the edge of the structural member, a configuration that produces lower static strength.
- Details such as poor rivet patterns, dimpling, and countersinking degrade fatigue strength.

In addition, riveting is a very labor-intensive joining method. Man-hours are the most expensive part of any ship construction process. This is yet another reason that riveting has become antiquated and not often found as part of the skilled labor group found in today's shipyards.

A sealing compound is needed in joints to provide water tightness; whereas, in welded seams, the joint is inherently watertight.

#### 6.1.2. Material Selection

The rivet material should be as close to possible to the material being joined. Rivets shall be made of aluminum meeting ASTM B 316 or 300 series stainless steel (4). For marine use, only the 5056-H32 alloy rivets should be used. The rivets are specified to meet MIL-R-5674 (128), which has now been superseded by NASM5674, which is published by the Aerospace Industries Association of America (115).

Corrosion must be carefully considered when using fasteners of different materials than that of the material being joined together. This is to avoid the creation of a cathodic connection. This will cause the fastener to corrode and loosen potentially causing the joint to fail.

Requirements (115):

- The finish holes for cold-driven rivets shall not be more than 4% greater than the nominal diameter of the rivet.
- The distance between rivet centers shall not be less than three times the nominal diameter of the rivet.
- The distance from the center of a rivet to an edge of the joining material shall not exceed 1.5 times the nominal diameter of the rivet.
- Aluminum rivets shall not carry any tensile loads.
- For aluminum rivets, the design shear strength†  $\phi R_n$  and the allowable strength  $R_n/\Omega$  shall be determined for the limit state of shear rupture as follows (115):

$$\begin{aligned}\Phi &= 0.65 \text{ (Load and Resistance Factor Design(LRFD))} \\ \Omega &= 2.34 \text{ (Allowable Stress Design (ASD) building type structures)} \\ \Omega &= 2.64 \text{ (ASD bridge-type structures)}\end{aligned}$$

**Table 7. Advantages and Disadvantages of Joining Methods**

	<b>Riveting</b>	<b>Bolting</b>	<b>Welding</b>	<b>Adhesives</b>
Design	<ul style="list-style-type: none"> <li>• <i>Variations in joint design are more significant than changes in the alloy used.</i></li> </ul>	<ul style="list-style-type: none"> <li>• <b>Nonmagnetic</b></li> <li>• <b>Electrical conductivity</b></li> </ul>	<ul style="list-style-type: none"> <li>• <b>Provides an air-/liquid-tight seal</b></li> <li>• <b>Able to be performed on a range of material thicknesses</b></li> <li>• <b>Able to be used in the production, modification, correction, and repair of castings</b></li> <li>• <b>Able to produce smooth seams (with grinding after the welding process)</b></li> <li>• <b>May be more efficient regarding material / weight</b></li> </ul>	
Installation	<ul style="list-style-type: none"> <li>• <i>Labor-intensive</i></li> <li>• <i>Small labor pool in modern shipyards</i></li> </ul>	<ul style="list-style-type: none"> <li>• <b>Adding colors to anodization coatings can assist in identification during installation.</b></li> <li>• <i>Susceptible to galling.</i></li> </ul>	<ul style="list-style-type: none"> <li>• <b>Able to be performed manually / automated</b></li> <li>• <b>Depending on the process, may be able to employ portable equipment</b></li> </ul>	<ul style="list-style-type: none"> <li>• <b>Ease of Use</b></li> </ul>

Notes:

1) Advantages are denoted in **bold font**. Disadvantages are denoted in *italicized font*.

	<b>Riveting</b>	<b>Bolting</b>	<b>Welding</b>	<b>Adhesives</b>
Strength / Fatigue	<ul style="list-style-type: none"> <li>• High strength-to-weight ratio</li> <li>• Joints of high static strength do not necessarily have high fatigue strength.</li> <li>• Fatigue strength of a joint increases with the number of fasteners used, but not in proportion to the static strength.</li> <li>• In a multi-row lap joint, the edge rivets carry the highest load; therefore, as the number of rivets is increased, the fatigue strength is not increased proportionately.</li> <li>• The greatest fatigue strength is obtained with large diameter rivets placed close together and close to the edge of the structural member, a configuration that produces lower static strength.</li> <li>• Details such as poor rivet patterns, dimpling, countersinking degrade fatigue strength.</li> </ul>	<ul style="list-style-type: none"> <li>• <b>Weight/strength ratio – aluminum alloy fasteners have the highest strength-to-weight ratio of any metals in common use for fasteners. Their strength is comparable to that of low-carbon steel fasteners, and aluminum weight about 1/3 as much as steel or stainless steel fasteners.</b></li> <li>• Lower strength in comparison to a steel bolt of the same size.</li> <li>• Aluminum bolt is less rigid in comparison to a steel bolt of the same size.</li> <li>• Aluminum bolts are more prone to fatigue than steel bolts.</li> </ul>	<ul style="list-style-type: none"> <li>• Can Weaken Material</li> <li>• Requires Additional Structure</li> <li>• Fatigue issues</li> </ul>	
Corrosion	<ul style="list-style-type: none"> <li>• Susceptible to corrosion</li> </ul>	<ul style="list-style-type: none"> <li>• Resistance to atmospheric corrosion.</li> <li>• <b>Compatibility/galvanic corrosion – the use of aluminum fasteners in joints minimizes the danger of galvanic corrosion.</b></li> </ul>		
Fire		<ul style="list-style-type: none"> <li>• Aluminum bolts will give way in a fire before a welded seam.</li> </ul>		<ul style="list-style-type: none"> <li>• Lack of Strength in Fire</li> <li>• May produce toxic gases in a fire</li> </ul>

$$R_n = \pi D_h^2 F_{su} / 4 \quad (5)$$

Where:

$D_h$  = nominal diameter of the hole  
 $F_{su}$  = shear ultimate strength of rivet

The design bearing strength  $\phi R_n$  and the allowable bearing strength  $R_n/\Omega$  shall be determined for the limit state of bearing as follows (115):

$\Phi$  = 0.75 (LRFD)  
 $\Omega$  = 1.95 (ASD building type structures)  
 $\Omega$  = 2.20 (ASD bridge-type structures)

$$R_n = d_e t F_{tu} \leq 2 D_h t_{cp} F_{tu} \quad (6)$$

Where:

$d_e$  = distance from the center of the rivet to the edge of the part in the direction of the applied force  
 $t_{cp}$  = for plain holes, nominal thickness of the connected part; for countersunk holes, nominal thickness of the connected part must be less than 1/2 the countersunk depth  
 $F_{tu}$  = tensile ultimate strength of the connected part  
 $D_h$  = nominal diameter of the hole

## 6.2. Bolting

Bolted joints are one of the most common elements in structural design. A bolted joint consists of fasteners that capture and join other parts and is secured with the mating of screw threads. In the bolted joint, the bolt is tightened to a calculated clamp load, usually by applying a measured torque load. The joint is designed such that the clamp load is never overcome by the forces acting on the joint (and, therefore, the joined parts see no relative motion) (42).

Bolting is used in ship building mostly to attach equipment and is often overlooked. Bolting is a significant source of galvanic corrosion aboard a ship because of the use of different materials. Great care should be taken to avoid this, if possible.

The clamp load, also called preload, of a fastener is created when a torque is applied and is generally a percentage of the fastener's proof strength; a fastener is manufactured to various standards that define, among other things, its strength and clamp load. Torque charts are available to identify the correct torque for a fastener based on its property class or grade (42).

When a fastener is tightened, it is stretched and the parts being fastened are compressed; this can be modeled as a spring-like assembly that has a non-intuitive distribution of strain. External forces are designed to act on the fastened parts rather than on the fastener; as long as the forces acting on the fastened parts do not exceed the clamp load, the fastener is not subjected to any increased load (42).

Engineered joints require the torque to be accurately set. Setting the torque for fasteners is commonly achieved using a torque wrench. The clamp load produced during tightening is higher than 75% of the fastener's proof load. The torque value is dependent on the friction produced by the threads and by the fastened materials' contact with both the fastener head and the associated nut. Moreover, this friction can be affected by the application of a lubricant or any plating (e.g., cadmium or zinc) applied to the threads. The fastener's standard defines whether the torque value is for dry or lubricated threading, as lubrication can reduce the torque value by 15% to 25%. Lubricating a fastener designed to be torqued dry could over-tighten it, which may damage threading or stretch the fastener beyond its elastic limit, thereby reducing its ability to clamp a joint (42).

The more accurate method for setting the clamping force relies on defining or measuring the screw extension; for instance, measurement of the angular rotation of the nut can serve as the basis for defining screw extension on thread pitch (42).

A sealant is required on joints to ensure a watertight seal.

### 6.2.1. Advantages and Disadvantages

The characteristics of aluminum that cause it to be selected for a wide range of end products also make it desirable as a material for nuts and bolts (42):

- Resistance to atmospheric corrosion.
- High weight/strength ratio – aluminum alloys fasteners have the highest strength-to-weight ratio of any metals in common use for fasteners. Their strength is comparable to that of low-carbon steel fasteners and aluminum weight about 1/3 as much as steel or stainless steel fasteners.
- Electrical conductivity.
- Nonmagnetic.
- Compatibility/galvanic corrosion – the use of aluminum fasteners in joints minimizes the danger of galvanic corrosion.
- Color identification/corrosion resistance – inherent corrosion resistance can be increased by anodizations for highly corrosive applications. The anodizations can be dyed a variety of different colors for identification purposes.

Some of the disadvantages of aluminum bolts include:

- Lower strength in comparison to a steel bolt of the same size.
- An aluminum bolt is less rigid in comparison to a steel bolt of the same size.
- Aluminum bolts are more prone to fatigue than steel bolts.
- Galvanic corrosion.

#### 6.2.2. Material Selection

When using aluminum fasteners:

- Aluminum alloys for nuts and bolts are relatively limited. Unless the proper alloy is used with the correct age and heat treatment, corrosion and strength issues can be catastrophic. All procedures shall meet MIL-H-6088 (42). Bolts that have rolled threads after aging and heat treating have a slightly better tensile strength than bolts with cut threads or rolled threads before heat treating (4).
- The most common alloy is 2024-T4, which has good strength, toughness, and corrosion resistance. Where a higher strength is desired, fasteners manufactured from 7075-T73 or 7050-T73 exist but are both rare and costly. Bolts shall meet ASTM F 468 (4).
- To obtain full strength of aluminum fasteners and avoid stress corrosion cracking of the aluminum, the nut must be 6061-T6 or 6262-T6 and meet ASTM F 467.
- Flat washers should be made of 2024-T4 and spring washers shall be 7075-T6 (4).

When bolting aluminum members, using:

- Aluminum fasteners – see above (4)
- Carbon steel fasteners – Carbon steel fasteners shall have a hot zinc coating meeting ASTM A 153 or a mechanically deposited zinc coating meeting ASTM B 695 and should be lubricated to ASTM A 563. The zinc coating should be adequate enough to provide corrosion protection in the assumed working environment (4). Note, that use of a zinc coating may increase the probability of hydrogen embrittlement.
- Stainless steel fasteners – All fasteners should be 300 series. Bolts shall meet ASTM F 593, A 193, or A 320. Nuts will meet ASTM F 594 or A 194 (4).

#### 6.2.3. Installation Considerations

Installation methods for aluminum fasteners are similar to those used for other materials, but if over-tightened, aluminum fasteners may be damaged more quickly than those of other materials. Therefore, more attention needs to be paid to the prescribed procedure (42).

Whether the procedure uses a predetermined torque value or “the turn of the nut” from a specified snug position, it should be noted that the clamping load can vary widely due to the variables of thread fit, bearing surface condition, and lubrication (42).

The installation procedure needs to be developed properly to define the method of tightening nut and bolts in a bolted connection under controlled conditions. Several factors that affect torque and their mitigating circumstances are (42):

- The hardness of the bolts, nut, and joint members
- Surface finishes
- The type of materials used for each fastener component
- The thickness, condition, consistency, and type of plating used on each
- The manufacturing process used to form the threads (e.g., rolled versus cut threads)
- The thread form
- Hole finish, alignment, and concentricity
- Burrs around the edges of the hole
- Whether or not the holes have been countersunk
- Type, number, size, location, and hardness of washers being used
- The type of tool used to tighten the fastener
- The speed of the tightening operation
- The fit of the wrench on the nut or bolt
- Which is receiving the torque application, the nut or bolt
- Number of times the fastener has been used

Other factors that would affect the torque, external to geometric factors are (42):

- Non-parallel or warped surfaces
- Tool accuracy
- The operator
- Job conditions

Proper lubrication in an aluminum bolted connection cannot be emphasized enough. It is common practice to use bulk lubricated nuts so the threads and bearing face are lubricated. Most commercially available nuts are waxed by the manufacturer, but the user should ensure this has been done. If the bolt is to be tightened, then the bolt will have to be lubricated which again is best done by the bulk method to ensure the threads and head joining surfaces are lubricated. Coatings are also a source of torque modification and corrosion preventative (42).

#### 6.2.4. Requirements

- The nominal diameter of holes for bolts shall not be more than 1/16” greater than the nominal diameter of the bolt unless slip-critical connections are used (4).

- The distance between bolt centers shall not be less than 2.5 times the nominal diameter of the bolt (4).
- The distance from the center of a bolt to an edge of a part shall not be 1.5 times the nominal diameter of the bolt (4).
- For aluminum bolts, the design tension strength  $\phi R_n$  and allowable tension strength  $R_n/\Omega$  shall be determined for the limit state of tensile rupture as follows (4):

$$\begin{aligned}\Phi &= 0.65 \text{ (LRFD)} \\ \Omega &= 2.34 \text{ (ASD building type structures)} \\ \Omega &= 2.64 \text{ (ASD bridge type structures)}\end{aligned}$$

$$R_n = \left( \pi \left( D - \frac{1.191}{4n^2} \right) \right) F_{tu} \quad (7)$$

Where:

$$\begin{aligned}F_{tu} &= \text{tensile ultimate strength of the bolt} \\ n &= \text{number of threads per inch} \\ D &= \text{nominal diameter of the bolt}\end{aligned}$$

- For aluminum bolts, the design shear strength  $\phi R_n$ , and the allowable shear strength  $R_n/\Omega$  shall be determined for the limit state of shear rupture as follows:

$$\begin{aligned}\Phi &= 0.65 \text{ (LRFD)} \\ \Omega &= 2.34 \text{ (ASD building type structures)} \\ \Omega &= 2.64 \text{ (ASD bridge type structures)}\end{aligned}$$

- For bolts with threads in shear plane:

$$R_n = \left( \pi \left( D - \frac{1.191}{4n^2} \right) \right) F_{tu} \quad (8)$$

- For bolts with threads out of shear plane:

$$R_n = \pi \frac{D^2}{4} F_{tu} \quad (9)$$

Where:

$$\begin{aligned}F_{tu} &= \text{tensile ultimate strength of the bolt} \\ n &= \text{number of threads per inch} \\ D &= \text{nominal diameter of the bolt}\end{aligned}$$

- The design bearing strength  $\phi R_n$  and the allowable bearing strength  $R_n/\Omega$  shall be determined for the limit state as follows (4):

$$\begin{aligned}\Phi &= 0.75 \text{ (LRFD)} \\ \Omega &= 1.95 \text{ (ASD building type structures)} \\ \Omega &= 2.20 \text{ (ASD bridge type structures)}\end{aligned}$$

- For a bolt in a hole:

$$R_n = d_c t_{cp} F_{tu} \leq 2 d t_{cp} F_{tu} \quad (10)$$

- For a bolt in a slot with a slot perpendicular to the direction of force:

$$R_n = 1.33 D t_{cp} F_{tu} \quad (11)$$

And the edge distance perpendicular to the slot length and slot length shall be sized to avoid overstressing the material between the slot and the edge of the part.

Where:

$$\begin{aligned}d_c &= \text{distance from center of the bolt to the edge of the part in the direction of the force} \\ t_{cp} &= \text{for plain holes, thickness of the connected part; for countersunk holes, thickness of the connected part less 1/2 the countersink depth} \\ F_{tu} &= \text{tensile ultimate strength of the connected part} \\ D &= \text{nominal diameter of the bolt}\end{aligned}$$

#### 6.2.5. Bolt Pull Through and Tear Out

Bolted joints should be analyzed for bolt pull through and bolt tear out. Bolt pull through occurs when a force is applied to the bolt normal to the plating through which the bolt is attached. To prevent pull through, the joint is designed such that the pull through stress is less than the allowable stress of the plating material. The pull-through stress is found using Equation (12):

$$\sigma_{PT} = \frac{P_N}{1.5\pi D t} \quad (12)$$

Where:

$$\begin{aligned}P_N &= \text{force normal to the plate surface} \\ D &= \text{Nominal diameter of the bolt} \\ t &= \text{thickness of the plate}\end{aligned}$$

Bolt tear-out occurs when a force is applied to the bolt parallel to the plating through which the bolt is attached. To

prevent tear-out, the joint is designed such that the pull through stress is less than the allowable stress of the plating material. The tear-out stress is found using Equation (13).

$$\sigma_{TO} = \frac{P_p}{2(D_{edge}-0.32D)t} \quad (13)$$

Where:

- $P_p$  = force parallel to the plate surface
- $D_{edge}$  = distance from the center of the bolt to the plate edge
- $D$  = nominal diameter of the bolt
- $t$  = thickness of the plate

### 6.3. Welding

Welding is a process that joins two materials, usually metals, by melting<sup>12</sup> the material to form liquid droplets along the materials' surfaces to be joined and allowing the liquid droplets to coalesce into a large puddle and solidify, forming a solid seam. In some cases, pressure is needed as well to force the materials' droplets together. The material that forms the molten pool comes from both the materials to be joined as well as any filler that is used. Welding can be subdivided into different types: pressure and fusion types. The source of heat for these methods is generated from a gas flame, an electric arc, electrical resistance, a laser, friction, ultrasound, and explosives. This guide will only focus on electric arc, friction processes, and explosive processes as these are the most commonly used in shipbuilding.

Welding has many advantages as a joining mechanism:

- Provides an air-/liquid-tight seal
- Able to be performed on a range of material thicknesses
- Able to be performed manually / automated
- Depending on the process, may be able to employ portable equipment
- Able to be used in the production, modification, correction, and repair of castings
- Able to produce smooth seams (with grinding after the welding process)
- Efficient regarding material / weight

Welding has had profound effects on shipbuilding as it is now the preferred method of joining metal. Welding is one of the major, if not the single major category of production hours for typical shipbuilding projects. The quality of the weld and the weldment, the choice of welding technique,

<sup>12</sup> This is in contrast to soldering or brazing, which does not melt a significant amount of the material of the joined pieces but only the filler material.

and the effect of the parent metal, in this case aluminum, are the three factors that affect the welding production hours for a ship build (123).

#### 6.3.1. Processes

Welding processes are vast and varied. The most commonly used in manufacturing, especially shipbuilding are Gas Metal Arc Welding (GMAW), Gas Tungsten Arc Welding (GTAW), Friction Stir Welding (FSW), and Explosion Welding. Aluminum alloys used in marine construction are readily weldable by inert gas arc processes. The gas arc metal processes predominate because of higher production speeds and greater economy. These fusion type processes can be described by the characteristics:

- Heat source intensity
- Heat input rate per unit of weld
- Shielding methods

The heat input rate per unit length of weld,  $q$ , can be expressed by (123):

$$q = \frac{hVI}{v} \quad (14)$$

Where:

- $v$  = the welding speed
- $H$  = the proportion of arc energy transferred to the work piece as heat
- $V$  = the arc voltage
- $I$  = the arc current

This calculation for heat input rate is an important variable in fusion welding, since it determines heating and cooling rates and weld pool size. This directly affects grain size in the weld metal and in the solid metal at the weld pool boundary.

Requirements and recommendations for welding in aluminum hull construction are contained in the rules of the classification societies as in the ABS Rules for Materials and Welding (15), for example.

##### 6.3.1.1. Gas Metal Arc Welding (GMAW)

Gas Metal Arc Welding (GMAW), also referred to as Metal Inert Gas (MIG) or Metal Active Gas (MAG) welding<sup>13</sup>, employs an electric arc that forms between a continuously-

<sup>13</sup> GMAW is also referred to by several other expressions: CO<sub>2</sub> welding, fine wire welding, spray arc welding, pulse arc welding, dip transfer welding, short-circuit arc welding, and multiple trade names.

fed, consumable filler electrode and the metal at the weld joint. A shielding gas envelopes the immediate area being welded and protects the weld from contamination by the atmosphere. GMAW is the most important welding technology of modern shipbuilding. Several commercially available combinations of shielding gases are available to use with GMAW but generally they consist of a combination of CO<sub>2</sub>, O<sub>2</sub>, hydrogen, argon, and helium. Different combinations allow for combining the advantages of the different shielding gas components (83). Figure 4 shows the different components required, and Figure 5 shows the welding gun at the joint.

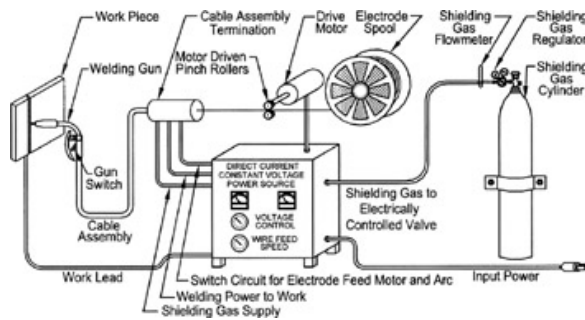

Figure 4. GMAW Welding Equipment (63)

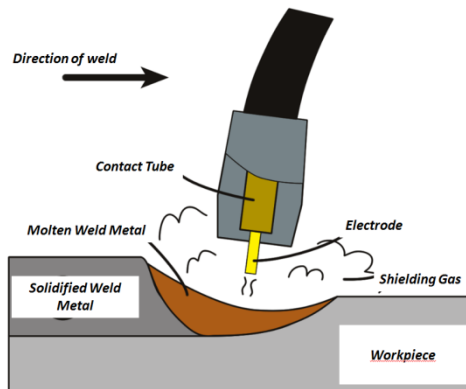

Figure 5. GMAW Weld Tip (114)

### 6.3.1.2. Gas Tungsten Arc Welding (GTAW)

Gas tungsten arc welding (GTAW), also known as tungsten inert gas (TIG) welding, is an arc welding process that uses a non-consumable, tungsten electrode to produce the weld. The weld area is protected from atmospheric contamination by a shielding gas (usually an inert gas such as argon), and a filler metal is normally used, though some welds, known as autogenous welds, do not require it. A constant-current welding power supply produces energy that is conducted across the arc through a column of highly ionized gas and metal vapors known as plasma. In the GTAW torch, the electrode is extended beyond the shielding gas nozzle. The arc is ignited by high voltage, high frequency (HF) pulses, or by touching the electrode to the work piece and

withdrawing to initiate the arc at a preset level of current (66).

Selection of electrode composition and size is not independent and must be considered in relation to the operating mode and the current level. Electrodes for DC welding are pure tungsten or tungsten with 1% or 2% thoria, the thoria being added to improve electron emission which facilitates easy arc ignition. In AC welding, where the electrode must operate at a higher temperature, a pure tungsten or tungsten-zirconium electrode is preferred as the rate of tungsten loss is somewhat lesser than with thoriated electrodes, and the zirconium aids retention of the 'balled' tip (66).

GTAW is viewed as the best, if not most efficient way to weld aluminum because of the operator's ability to control weld temperature. It is also used for welding where great precision is required (66). Figure 6 and Figure 7 depict the components and weld process.

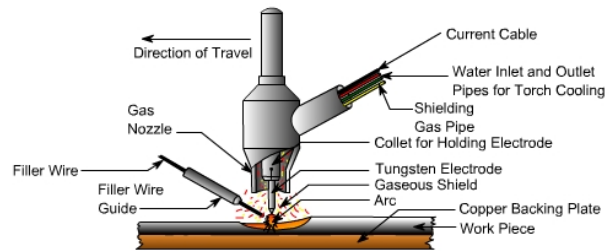

Figure 6. Principles of GTAW (66)

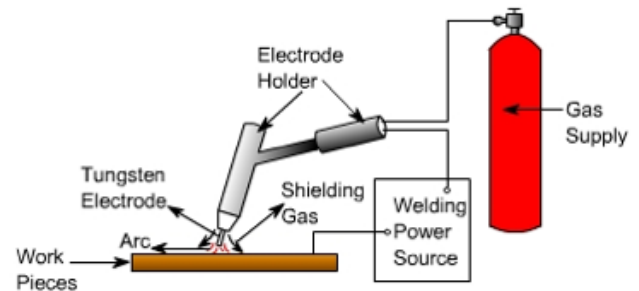

Figure 7. Schematic Diagram of GTAW System (66)

### 6.3.1.3. Friction Stir Welding (FSW)

Friction stir welding (FSW) is a specific type of friction welding which produces a welded joint by traversing a rotating tool along the edges of the joint. It is considered a solid state welding process. The tool includes a pin or probe which is plunged into the material along the joint. A FSW pin tool consists of a concave shoulder and a protruding pin. The length of the pin is approximately equal to the thickness of the material being welded. The pin tool is rotated and slowly plunged into the base material until the tool shoulder



contacts the top surface of the base material. At this point the tip of the pin is in close proximity to the anvil.

The rotating pin tool is traversed along the weld seam, generating friction heat at the interfaces of the shoulder and pin with the base material. The rotational speed, travel speed and axial load on the pin are designed to produce sufficient heat to plasticize the material. A combination of extrusion and forging between the pin tool shoulder and the anvil generates a solid state weld in the base material.

The friction causes the material to become plastic (but not melt), mix, and fill the gap between the two work pieces. The rotational speed of the tool, shape of the probe, and translational speed of the tooling varies by alloy and material thickness. The process does not use any shielding gas or filler material. It has typically been used for butt joints, but has been used for combined butt / lap, single lap, two-piece T butt, and edge butt joints (47). FSW also provides an excellent method of assembling stiffened panels together. The welding of the material is facilitated by severe plastic deformation in the solid state, involving dynamic recrystallization of the base material. The process has best been adapted to aluminum welding in shipbuilding. Figure 8 depicts the components and weld process.

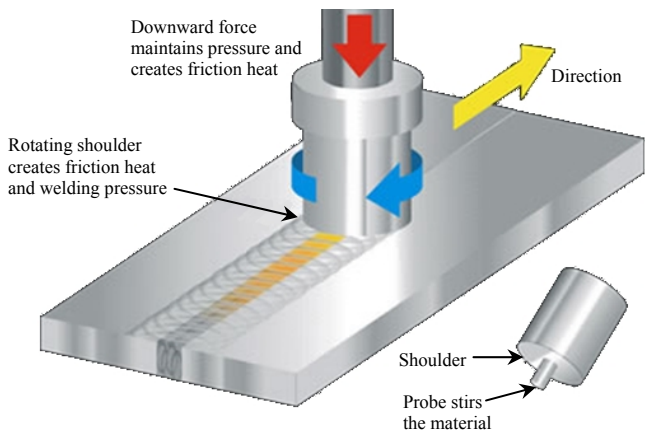

Figure 8. **Schematic Diagram of the FSW Process (58)**

A number of potential advantages of FSW over conventional fusion-welding processes include the following:

- Produces good mechanical properties in the weld. A hardness drop of just 10% to 20% has been measured (100).
- May be used on alloys that are crack-sensitive when they are welded with normal fusion welding processes.
- Conducted with improved safety due to the absence of toxic fumes or the spatter of molten material.
- Uses no consumables. A threaded pin made of conventional tool steel (e.g., hardened H13) can weld

over 1,000 m (~3281 ft) of aluminum, and no filler or gas shield is required for aluminum (100).

- Easily automated on simple milling machines, with lower setup costs and less training.
- Can operate in all positions (horizontal, vertical, etc.), as there is no weld pool.
- Generally good weld appearance and minimal thickness under/over-matching, thus reducing the need for expensive machining after welding.
- Low environmental impact.
- There is little thermal stress or distortion.
- The weld is good and reproducible.

However, some disadvantages of the process have been identified:

- Exit hole left when tool is withdrawn.
- Large downward forces required with heavy-duty clamping necessary to hold the plates together.
- Less flexible than manual and arc processes (difficulties with thickness variations and non-linear welds).
- Often slower traverse rate than some fusion welding techniques, although this may be offset if fewer welding passes are required.
- High cost and size of necessary equipment.
- Difficult to weld complex joints.

#### 6.3.1.4. Explosion Welding

Explosion welding is characterized by an extremely high pressure for a short time, which essentially forces the two materials together. The surfaces to be joined are brought together at a very high speed so that the impact energy plasticizes them and produces a welded bond. There is no melt zone present during this process. An explosion-welded joint exhibits weld strength at least as great as the weaker of the two base metals. The welded product is routinely tested using pull tests for ultimate tensile strength, and ultrasonic inspection to reveal interior non-bonded areas. The U.S. Navy has adopted a specification MIL-J-24445 (127) for joining aluminum to steel. In addition, ASME publishes specifications detailing clad products. Figure 9 depicts the components and weld process.

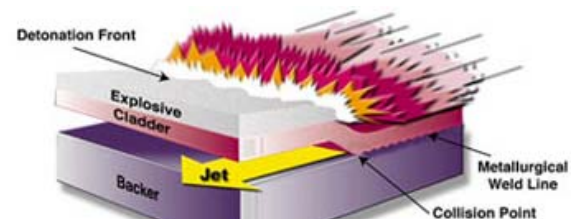

Figure 9. **Explosion Clad Plate Manufacturing Process (57)**

A common product of explosion welding is the bi-metallic transition insert. Bi-metallic inserts are the popular method of joining aluminum to steel. The bi-metallic insert's

primary use in shipbuilding is providing the interface between a steel hull and an aluminum superstructure. This has provided the naval architect the capability to maximize the benefits of steel in the hull structure and the benefits of aluminum lightweight and corrosion resistance properties for superstructures.

Additional examples of explosion welding in shipbuilding are the aircraft tie downs on an aircraft carrier. The steel aircraft tie-down is explosion welded to the aluminum flight deck of an aircraft carrier. There are steel deck sockets and copper-nickel deck drains that are also explosion welded to aluminum which provide attachment to an aluminum deck.

### 6.3.2. Design for Welding

Economy in ship construction and improvements in the serviceability and service life of ship structures can be enhanced if several principles basic to welded structures are observed in the design process. The principles are derived both from service experience and from studies of the causes and prevention of structural failures of ships.

#### 6.3.2.1. Material Considerations

There are several considerations that should be taken into account when planning the use of welding to join structural elements. Most non-ferrous metals, including aluminum, are not hardened by quenching, but by cold working, which results in a finer grain structure. Aluminum is welded by melting the filler material and/or the base material, and it is necessary to protect them from the atmosphere and gases that could result in porosity. The metal must be allowed to contract during cooling without overstressing the joint which leads to cracking.

Great care must be taken while welding aluminum so as not to burn through the material because it has a much lower melting point than ferrous materials. Pure aluminum melts at 1,215°F, and its alloys melt at much lower temperatures (as low as 900°F). The welder must watch for a “wet” appearance of the surface to indicate melting.

Welding will remove some of the material’s strength that was achieved by cold-working, but the strength will not be lower than that of the material in a fully annealed condition. The welding procedure should attempt to confine the heat and loss of strength properties to the narrowest possible zone, usually by welding on a steel welding table.

Joint edges may be prepared by mechanical means such as saws, millers, and routers and by plasma arc welding, especially on thicker materials. Plasma-arc can now be used for beveling and back gouging. Shearing is not recommended for preparing plate edges because it can entrap oil or dirt.

Care should be taken to remove oil, grease, markings, and other contaminants prior to welding. Also, degreasing chemicals and machining lubricants do not collect in crevices of the joints. This will cause imperfections and weaken the joint. Also, welding should be done before oxidation can reoccur on the material surface once it is removed. Care must be taken to ensure that the aluminum does not come into contact with steel. Aluminum is anodic to steel and will end up “sacrificing”.

In general, strength is the biggest issue in welding aluminum. Welding in the vicinity of heat treated alloys transforms it into an annealed condition. The effect is a reduction in tensile properties in the vicinity of the weld annealed or non-work hardened values.

#### 6.3.2.2. Weldability

Perhaps the most basic consideration is whether the material is weldable and what welding processes are able to be used. Table 8 provides a summary of relevant properties for a range of heat-treatable and non-heat-treatable wrought and cast aluminum alloys.

#### 6.3.2.3. Weld Strength

The as-welded strength is another design consideration when picking component and filler alloys. The ASM Aluminum Specialty Handbook (53) contains tables (Tables 6, 7, 9, and 10) with as-welded ultimate strengths of heat treatable and non-heat treatable alloys. Table 7 in (53) also includes properties in the post-weld heat treated and aged condition. Table 3 includes values for some of the maritime alloys.

#### 6.3.2.4. Hydrogen Solubility

Hydrogen dissolves rapidly in the molten aluminum that is produced during the welding process but has reduced solubility in the solid aluminum that is formed as the material cools. Excess hydrogen forms gas porosity in the weld material, producing weak welded joints; this is an especially serious problem for 5xxx series aluminum alloys, which are sensitive to the formation of a hydrated oxide. Hydrogen comes from many sources: lubricant left on the joined material or filler, moisture or oxidation (see Section 6.3.1.2), moisture leaks or condensation inside the nozzle of a water-cooled torch, or moisture in the shielding gas (53).

**Table 8. Physical Properties and Weldability of Common Aluminum Alloys (53)**

Alloy	Approximate Melting Range		Thermal Conductivity at 25°C (77°F)		Electrical Conductivity <sup>14</sup> %IACS	Weldability <sup>15</sup>				
	°C	°F	W/m-K	Btu/ft-hr-°F		Gas	Arc with Flux	Arc with Inert Gas	Resistance	Pressure
Non-Heat-Treatable Wrought Aluminum Alloys										
1060	646-657	1195-1215	234	135	62	A	A	A	B	A
1100	643-657	1190-1215	222	128	59	A	A	A	A	A
1650	646-657	1195-1215	234	135	62	A	A	A	B	A
3003	643-654	1190-1210	193	112	50	A	A	A	A	A
3004	629-654	1165-1210	163	94	42	B	A	A	A	B
5005	632-654	1170-1210	200	116	52	A	A	A	A	A
5050	624-652	1155-1205	193	112	50	A	A	A	A	A
5052, 5652	607-649	1125-1200	138	80	35	A	A	A	A	B
5083	574-638	1065-1180	117	67.5	29	C	C	A	A	C
5086	585-641	1085-1185	125	72.5	31	C	C	A	A	B
5154, 5254	593-643	1100-1190	125	72.5	32	C	C	A	A	B
5454	602-646	1115-1195	134	77.5	34	B	B	A	A	B
5456	568-638	1055-1180	117	67.5	29	C	C	A	A	C
Heat-Treatable Wrought Aluminum Alloys										
2014	507-593	945-1100	154	89	40	X	C	B	B	C
2024	502-638	935-1180	121	70	30	X	C	C	B	C
2090	560-643	1040-1190	88	51	17	X	X	B	B	C
2219	543-643	1010-1190	121	70	30	X	C	A	B	C
2618	549-638	1020-1180	161	93	37	X	C	B	B	C
6009	560-649	1040-1200	167	97	44	C	C	B	B	B
6013	579-649	1075-1200	150	87	38	C	C	B	A	B
6061	582-652	1080-1205	167	97	43	A	A	A	A	B
6063	616-654	1140-1210	200	116	53	A	A	A	A	B
6101	621-654	1150-1210	218	126	57	A	A	A	A	B
6262	582-652	1080-1205	172	99	44	C	C	B	A	B

<sup>14</sup> Equal volume at 20°C (68°F)

<sup>15</sup> Weldability ratings: A, readily weldable; B, weldable in most applications, but may require special technique or filler alloy; C, limit weldability, X, joining method not recommended.

Alloy	Approximate Melting Range		Thermal Conductivity at 25°C (77°F)		Electrical Conductivity <sup>14</sup> %IACS	Weldability <sup>15</sup>				
	°C	°F	W/m-K	Btu/ft-hr-°F		Gas	Arc with Flux	Arc with Inert Gas	Resistance	Pressure
6351	596-652	1105-1205	176	102	46	A	A	A	A	B
6951	616-654	1140-1210	198	114	52	A	A	A	A	A
7005	607-646	1125-1195	-	-	-	X	X	A	A	B
7039	577-638	1070-1180	154	89	34	X	X	A	A	B
7075	477-635	890-1175	130	75	33	X	X	C	B	C
7079	482-638	900-1180	125	72	32	X	X	C	B	C
7178	477-629	890-1165	125	72	31	X	X	C	B	C
Non-Heat Treatable Cast Aluminum Alloys – Sand Castings										
208.0	521-632	970-1170	121	70	31	C	C	B	B	X
443.0	577-632	1070-1170	146	84	37	A	A	A	A	X
511.0	588-638	1090-1180	141	82	36	X	X	A	A	X
512.0	588-632	1090-1170	146	84	38	X	X	B	B	X
514.0	599-638	1110-1180	137	79	35	X	X	A	A	X
535.0	549-632	1020-1170	99	58	23	X	X	A	A	X
710.0	599-649	1110-1200	137	79	35	C	C	B	B	X
712.0	599-638	1110-1180	159	92	40	C	C	A	B	X
Non-Heat Treatable Cast Aluminum Alloys – Permanent Mold Castings										
208.0	521-632	970-1170	121	70	31	C	C	B	B	X
238.0	510-599	950-1110	104	60	25	C	C	B	A	X
443.0	577-632	1070-1170	146	84	37	A	A	A	A	X
A444.0	577-632	1070-1170	159	92	41	A	A	A	A	X
513.0	582-638	1080-1180	133	77	34	X	X	A	A	X
711.0	599-643	1110-1190	159	92	40	B	B	A	A	X
Non-Heat Treatable Cast Aluminum Alloys – Die Castings										
360.0	570-588	1060-1090	146	84	37	C	X	C	B	X
380.0	521-588	970-1090	108	62	27	C	X	C	B	X
413.0	577-588	1070-1090	154	89	39	C	X	C	B	X
518.0	538-621	1000-1150	99	58	24	X	X	C	B	X
Heat-Treatable Cast Aluminum Alloys – Only Sand Castings										
A201.0	571-649	1060-1200	121	70	30	C	C	B	B	X
240.0	516-604	960-1120	95	55	23	X	X	C	B	X
A242.0	527-638	980-1180	146	84	38	X	X	B	B	X
295.0	521-643	970-1190	141	82	35	C	C	B	B	X
520.0	449-599	840-1110	87	50	21	C	C	B	C	X
Heat-Treatable Cast Aluminum Alloys – Only Permanent Mold Castings										

Alloy	Approximate Melting Range		Thermal Conductivity at 25°C (77°F)		Electrical Conductivity <sup>14</sup> %IACS	Weldability <sup>15</sup>				
	°C	°F	W/m-K	Btu/ft-hr-°F		Gas	Arc with Flux	Arc with Inert Gas	Resistance	Pressure
332.0	521-582	970-1080	104	60	26	X	X	B	B	X
333.0	521-588	970-1090	117	68	29	X	X	B	B	X
336.0	538-571	1000-1060	117	68	29	C	C	B	B	X
354.0	538-599	1000-1110	125	72	32	C	C	B	B	X
Heat-Treatable Cast Aluminum Alloys – Sand and Permanent Mold Castings										
222.0	521-627	970-1160	130	75	33	X	X	B	B	X
242.0	527-638	970-1180	133	77	34	X	X	C	B	X
319.0	521-604	970-1120	112	64	27	C	C	B	B	X
355.0	549-621	1020-1150	150	87	39	B	B	B	B	X
C355.0	549-621	1020-1150	146	84	39	B	B	B	B	X
356.0	560-616	1040-1140	150	87	41	A	A	A	A	X
A356.0	560-610	1040-1130	150	87	40	A	A	A	A	X
A357.0	554-610	1030-1130	159	92	40	B	B	A	A	X
359.0	566-599	1050-1110	137	79	35	B	B	A	A	X

#### 6.3.2.5. Electrical Conductivity

Aluminum has high electrical conductivity (approximately 62% of copper), which allows several conveniences with regards to welding (53):

- The ground connection can be attached to any point on the work piece. This is in preference to attachments on a steel table due to the poor ground path through any rust on the steel and oxide on the aluminum.
- Long contact tubes, which promote multiple contact points, can be used with GMAW guns due to the lack of resistance heating of the electrode. This reduces arcing especially in the case when the arc is initiated using a constant-voltage power supply and a fast electrode “run in” speed.

#### 6.3.2.6. Thermal Conductivity

Aluminum also has high thermal conductivity (approximately six times that of steel) and specific heat (approximately twice that of steel); however, these characteristics provide issues of concern with regards to welding (53):

- Higher heat inputs are required as compared to steel because of its high specific heat.
- Welding parameters must be continually adjusted since the heat is conducted ahead of the arc.
- Aluminum is sensitive to changes in heat input. Variations in penetration and fusion can occur as a result.

#### 6.3.3. Preparation / Cleaning

Preparation and cleaning of the aluminum prior to welding is of paramount importance. Moisture, grease, anodizations, and oxidation may all be present on the material and must be removed prior to welding. Impurities on the surface will create a poor fusion and weaken the overall strength of the joint.

##### 6.3.3.1. Removal of Oxidation

Aluminum oxidizes immediately upon exposure to air. While this oxide layer provides corrosion resistance to aluminum, if it is not removed properly, any un-melted oxide will be trapped in the weld and may cause a reduction in ductility, lack of fusion, and/or weld cracking (49).

The oxidation that forms on the aluminum has a melting point of 3,700°F, and it is impractical to remove (especially by certain welding processes) by the heat of the welding process.

There are several methods of removal (49): mechanical, chemical or electrical means. Mechanical removal can be

done with a sharp tool, sandpaper, or a stainless steel wire brush.

There are two chemical solutions that can be used: etching types (composed of alkaline solutions) or non-etching solutions. Non-etching solutions are less abrasive but should only be used for relatively clean parts. Etching solutions are more effective but should be used with care so as not to allow excessive etching. This is usually done by controlling the time of exposure to the chemical solution. If the parts are dipped into the solution, hot and cold rinsing are suggested. Another chemical method of removing oxidation is via flux. Typically, the oxide layer is thin enough to be removed by flux. However, the flux leaves chlorides and fluorides, which must be removed after the welding operation in order to prevent corrosion.

The electrical method occurs during the half cycle during gas tungsten arc welding (GTAW) when the electrode is positive. The removal occurs via cathodic bombardment and blasts away the oxide to produce a clean surface. As a result, inert-gas arc welding has increased in acceptance as a joining method for aluminum (49).

The oxide layer immediately begins to reform and thicken after cleaning, and welds should be conducted within eight hours of cleaning in order to ensure quality welded joints (49).

Spooled bare electrode must be stored in a dry, heated area to prevent oxidation (53).

##### 6.3.3.2. Removal of Anodization Coatings

Anodizations have the same effect as the aluminum oxide. They can be removed by sanding, scraping, and wire brushing, but a chemical process is the preferred method.

##### 6.3.3.3. Preheating

Preheating of aluminum and its alloys is highly desirable and is necessary in most cases to prevent high stresses and distortion when welding and to minimize cracking. Better fusion of thick plates is also obtained by preheating, but is often seen as impractical on larger pieces.

Preheating should be to 300°F-500°F and uniform throughout the material. Care must be taken not to heat to a higher temperature because of the low melting point of aluminum.

##### 6.3.3.4. Precipitation

Aluminum alloys that are heat-treatable are subject to considerable precipitation where the alloying elements are brought to the surface as the result of welding heat. The elements will surface to the edge of the grains and will cause discoloration in the material parallel to the weld seam.

The loss of these materials weakens the parent material and may result in cracking. The general solution is to use a filler metal of higher alloy content than the material being welded and to use a fast welding method so as to limit and narrow the heat-affected zone.

### 6.3.3.5. Joint Design

The most commonly used types are butt and lap joints. A butt joint is created when the edges of two pieces are welded together; a lap joint occurs when the material is overlapping the other piece. Other examples of joints include corner joints, tee joints, and edge joints (131).

Joint types are chosen with regard to the welding method, geometry, and plate thickness. The ideal joint provides the required structural strength and quality without an unnecessarily large joint volume. The weld cost increases with the size of the joint, and the higher heat input will cause problems with impact strength and distortion (131).

The design of a joint is fundamentally determined by the geometry and required dimensions. Although the joint design is primarily established to meet strength and safety requirements, several other factors must be considered including (125):

- Whether the load will be in tension or compression and whether bending, fatigue, or impact stresses will be applied.
- How a load will be applied; that is whether the load will be steady, sudden, or variable
- The direction of the load as applied to the joint
- The cost of preparing the joint

Another factor is called joint efficiency, which is the ratio of strength of the joint to strength of the base material.

The square butt joint is used primarily for metals that are 3/16 inch or less in thickness. The joint is reasonably strong, but its use is not recommended when the metals are subject to fatigue or impact loads. Preparation of the joint is simple, since it only requires matching the edges of the plates together; however, as with any other joint, it is important that it is fitted together correctly for the entire length of the joint. Penetration of the material is needed to ensure proper strength; therefore, specified geometry should be used to ensure complete penetration (125). The square butt joint can be utilized to join plating in the superstructure.

When welding metals greater than 3/16 inch in thickness, it is necessary to use a grooved butt joint. The purpose of grooving is to give the joint the required strength. When using a grooved joint, it is important that the groove angle is sufficient to allow the electrode into the joint; otherwise, the weld will lack penetration and may crack. However, excess beveling should be avoided because this wastes both weld

metal and time. Depending on the thickness of the base metal, the joint is either single-grooved (grooved on one side only) or double-grooved (grooved on both sides). The single-V butt joint is for use on plates 1/4 inch through 3/4 inch in thickness. Each member should be beveled so the included angle for the joint is approximately 60 degrees for plate and 75 degrees for pipe. The double-V butt joint is used on metals thicker than 3/4 inch but can be used on thinner plate where strength is critical. Compared to the single-V joint, preparation time is greater, but less filler metal is used because of the narrower included angle. Because of the heat produced by welding, alternate weld deposits, welding first on one side and then on the other side, should be used. This practice produces a more symmetrical weld and minimizes warping (125). Figure 10 shows the most common types of butt joints.

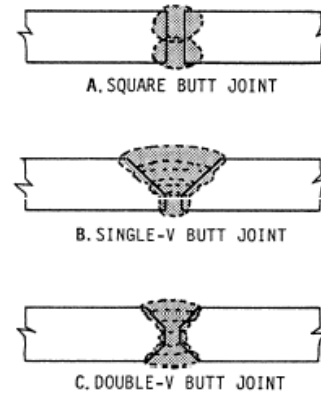

Figure 10. Common Butt Joints (125)

The single-V and double-V butt joint are typically utilized to join hull plating and welding deck sections together.

The flush corner joint is designed primarily for welding sheet metal that is 12 gauge or thinner. It is restricted to lighter materials, because deep penetration is sometimes difficult and the design can support only moderate loads. The half-open corner joint is used for welding materials heavier than 12 gauge. Penetration is better than in the flush corner joint, but its use is only recommended for moderate loads. The full-open corner joint produces a strong joint, especially when welded on both sides. It is useful for welding plates of all thicknesses (125). Figure 11 shows the most common types of corner joints.

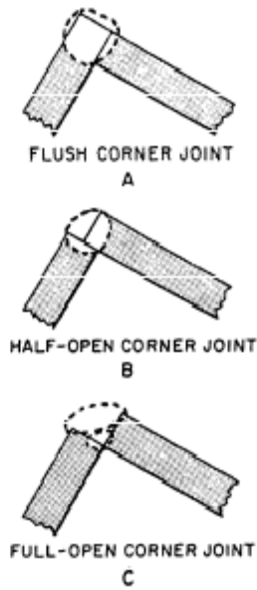

Figure 11. **Common Corner Joints (125)**

The tee joint requires a fillet weld that can be made on one or both sides. For maximum strength, weld metal should be placed on each side of the vertical plate. The single-bevel tee joint can withstand more severe loadings than the square tee joint, because of better distribution of stresses. It is generally used on plates of 1/2 inch or less in thickness and where welding can only be done from one side. The double-bevel tee joint is for use where heavy loads are applied and the welding can be done on both sides of the vertical plate. Figure 12 shows common Tee-Joints.

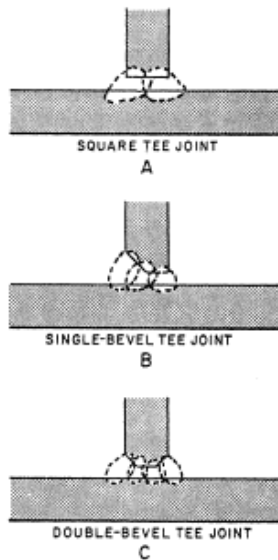

Figure 12. **Common Tee Joints (125)**

The single-fillet lap joint is easy to weld, since the filler metal is simply deposited along the seam. The strength of the weld depends on the size of the fillet. Metal up to 1/2 inch in thickness and not subject to heavy loads can be welded using this joint. When the joint will be subjected to heavy loads, the double-fillet lap joint should be used. When welded properly, the strength of this joint is very close to the strength of the base metal. Figure 13 shows common lap joints.

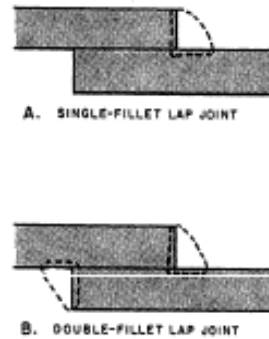

Figure 13. **Common Lap Joints (125)**

The flanged edge joint is suitable for plate 1/4 inch or less in thickness and can only sustain light loads. Figure 14 shows common edge joints.

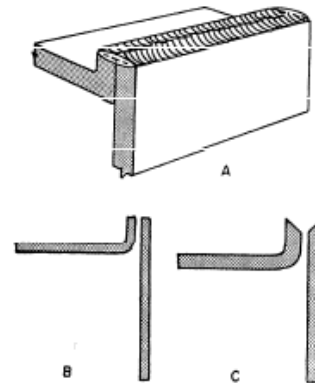

Figure 14. **Common Edge Joint Application (125)**

#### 6.3.4. Filler Alloy Selection

An important part of the weld design process is selecting the filler alloy for the joint. This affects the ease of welding, the strength of the weld, and the corrosion resistance. Table 9 provides filler selection criteria for joining 6061 and 6070 aluminum to other alloys using a variety of filler alloys. This is part of a much larger table (Table 14) from the ASM Specialty Handbook on Aluminum (53) which includes filler selection criteria for other combinations of alloys.



**Table 9. Filler Alloy Characteristics**

Alloy 1	Alloy 2	Filler Alloy	Filler Alloy Characteristics					
			W	S	D	C	T	M
6061,6070	5005, 5050	4043	A	B	C	A	A	-
		4145	A	B	D	B	A	-
		5183	B	A	B	-	-	A
		5356	B	A	A	-	-	A
		5556	B	A	B	-	-	A
	5052, 5652	5053	A	D	C	A	A	-
		5183	B	A	B	C	-	B
		5356	B	B	A	C	-	A
		5554	C	C	A	B	A	B
		5556	B	A	B	C	-	B
		5654	C	C	A	B	-	A
	5083, 5456	4043	A	D	C	A	-	-
		5183	A	A	B	A	-	A
		5356	A	B	A	A	-	A
		5554	B	C	A	A	-	A
		5556	A	A	B	A	-	A
		5654	B	C	A	A	-	B
	5086, 5356	4043	A	D	C	A	-	-
		5183	A	A	B	A	-	A
		5356	A	B	A	A	-	A
		5554	B	C	A	A	-	A
		5556	A	A	B	A	-	A
		5654	B	C	A	A	-	B
	514.0, A514.0, B514.0, F514.0, 5154, 5254	4043	A	D	C	A	-	-
		5183	B	A	B	C	-	B
		5356	B	B	A	C	-	A
		5554	C	C	A	B	-	B
		5556	B	A	B	C	-	B
		5654	C	C	A	B	-	A
	5454	4043	A	D	C	B	A	-
		5183	B	A	B	C	-	A
		5356	B	B	A	C	-	A
		5554	C	C	A	A	A	A
		5556	B	A	B	C	-	A
		5654	C	C	A	B	-	B
	6005, 6063, 6101, 6151, 6201, 6351, 6951	4043	A	C	B	A	A	-
		5183	B	A	A	C	-	A
		5356	B	A	A	C	-	A
		5554	C	B	A	B	B	A
		5556	B	A	A	C	-	A
		5654	C	B	A	B	-	B
	6061, 6070	4043	A	C	B	A	A	-
		5183	B	A	A	C	-	B
		5356	B	B	A	C	-	A
		5554	C	B	A	B	B	B
5556		B	A	A	C	-	B	
5654		C	B	A	B	-	B	

Notes:

1. A, B, C, and D represent relative ratings (where A is best and D is worst) of the performance of the two component base alloys combined with each group of selected filler alloys.
2. W, ease of welding (relative freedom from weld cracking); S, strength of welded joint in as welded condition (rating applies specifically to fillet welds, but all rods and electrodes rated will develop presently specified minimum strengths for butt welds); D, ductility (rating based on free bend elongation of the weld); C, corrosion resistance in continuous or alternate immersion of fresh or salt water; T, performance in service at sustained temperatures > 65°C (> 150°F); M, color match after anodizing
3. Combinations having no ratings are not recommended.

### 6.3.5. Residual Stresses

Residual stresses are stresses that remain once the original cause of stress has been removed. This is especially important to consider in the welding process because the heat from welding will cause local expansion which is accounted for in welding by either the molten metal or the placement of the parts being welded. Once the weld is finished and cools, some areas will contract more than others, creating residual stress. This produces large tensile stresses whose maximum value is approximately equal to the yield strength of the materials being joined, balanced by lower compressive residual stresses elsewhere in the component (125).

Prediction of residual stresses by numerical modeling of welding has improved in recent years. Modeling of welding is technically and computationally difficult, so simplification and idealization of the material behavior, process parameters, and geometry is unavoidable. Numerical modeling is a way to predict residual stress, but validation with experimental results is critical (125).

Residual stresses must be calculated and determined to verify joint strength as well as ensure there is enough supporting structure near the welded joint. Residual stress weakens the joint by putting stresses already in place, and creating a greater chance of failure from fatigue. If the joint can be properly designed, the pre-stresses can be eliminated or incorporated into the overall design.

Allowing for residual stresses in the assessment of performance varies according to the method of failure. It is not usually necessary to take into account residual stresses in calculations of the static strength of ductile materials. Design procedures for fatigue or buckling of welded structures usually make appropriate allowances for weld-induced residual stresses, and, therefore, it is not necessary to include them explicitly. Residual stresses have an effect on fracture in the brittle and transitional regimes, and the stress intensity, K, or energy release rate, G. Due to this, residual stresses must be calculated and included in the fracture assessment. K or G may be obtained as a function of stress distribution, crack size and geometry by various methods, including handbook solutions, weight functions, and FEA (125).

K is calculated as (85):

$$K = \sigma_0 \sqrt{\pi c} \quad (15)$$

Where:

- $\sigma_0$  = uniform tensile stress
- c = crack length (L/2)

L = seam length

The strain energy (U) released due to crack occurrence is:

$$U = \frac{\pi \sigma_0^2}{E} \left( \frac{L}{2} \right)^2 \quad (16)$$

Where:

- $\sigma_0$  = uniform tensile stress
- E = elastic modulus
- L = seam length (weld length)

Then the strain energy release rate (G) is:

$$G = \frac{\partial U}{\partial L} \quad (17)$$

$$= \frac{\pi \sigma_0^2 L}{E} \quad (18)$$

$$= \frac{K^2}{E} \quad (19)$$

Where:

- U = strain energy
- L = seam length (weld length)
- $\sigma_0$  = uniform tensile stress
- E = Young's modulus
- K = stress intensity

The theory of residual stress describes what is happening in this complex instance. The theory of residual stress is estimated as follows:

Stress:  $\sigma_x, \sigma_y, \sigma_z$

Seam length (weld length): L

Transverse stress on the seam:  $\sigma_{y0}$

$$\sigma_{y0} = \frac{E}{2L} \int_{-L/2}^{L/2} \frac{1}{1-x} \left( \frac{d[v]}{dx} \right)_x dx' \quad (20)$$

Where:

- E = elastic modulus
- [v] = dislocation, calculated using Equation (21)
- x = length along weld seam

$$[v'] = \sum_{n=1}^{\infty} A_n \sin n\theta \quad (21)$$

Where:

$$\begin{aligned} A_n &= \text{area of joint} \\ \theta &= \text{angle of joint} \end{aligned}$$

$$\sigma_{y0} = \frac{E}{2L} \sum n A_n \frac{\sin n\theta}{\sin \theta} \quad (22)$$

$$x = \frac{L}{2} \cos \theta \quad (23)$$

Mean Dislocation  $[\bar{v}']$ :

$$[\bar{v}'] = \frac{1}{L} \int_{-L/2}^{L/2} [v] dx \quad (24)$$

$$= \frac{1}{L} \int_0^{\pi} \frac{L}{2} \left( \sum_{n=1}^{\infty} A_n \sin n\theta \right) \sin \theta \cdot d\theta \quad (25)$$

$$= \frac{\pi}{4} A_1 \quad (26)$$

Thus, the magnitude of mean dislocation is determined only by the value  $A_1$ . This causes the strain energy,  $U$ , to become:

$$U = \int_{-L/2}^{L/2} \frac{1}{2} \sigma_{y0} [v] dx \quad (27)$$

$$= \frac{\pi}{16} E \left( \sum_{n=1}^{\infty} n A_n^2 \right) \quad (28)$$

$$= \frac{\pi}{16} E (1 + \delta) A_1^2 \quad (29)$$

Where:

$$\delta = \frac{1}{A_1^2} \left( \sum_{n=2}^{\infty} n A_n^2 \right) \quad (30)$$

#### 6.3.5.1. Distortion

Probably the most common cause of excessive distortion is from over welding. In order to reduce distortion, heating

and shrinkage forces should be kept to a minimum. The weld should be designed to contain only the amount of welding necessary to fulfill its service requirements. The correct sizing of welds to match the service requirement of the joint can help to reduce distortion. Welds should not be produced that are larger than necessary for a good bond. Welders should be provided with weld gauges so they are able to measure their welds to ensure they are not producing welds that are much larger than necessary. With butt joints, edge preparation, fit-up, and excessive weld buildup on the surface should be controlled in order to minimize the amount of weld metal deposited, and thereby reduce heating and shrinkage (46).

When welding thicker material, a double-V-groove joint requires about half the weld metal of a single-V-groove joint and is an effective method of reducing distortion. Changing to a J-groove or a U-groove preparation can also assist by reducing weld metal requirements in the joint (46).

Intermittent fillet welds should be used where possible. Often adequate strength requirements can be maintained and the volume of welding reduced by 70%, if the design allows, by using intermittent fillet welds over continuous welding (46).

Welding should be balanced around and positioned near to the neutral axis of the welded structure. Placing similarly-sized welds on either side of the joint centerline can balance one shrinkage force against another. Placing the weld close to the neutral axis of the structure may reduce distortion by providing less leverage for shrinkage stresses to move the structure out of alignment (46).

The number of weld beads should be reduced, if possible. Few passes with a large electrode are preferable to many passes with a small electrode. The additional applications of heat can cause more angular distortion in multi-pass single fillet welds and multi-pass single-V-groove welds (46).

The welding process to be used should be carefully selected. The process that can provide the highest welding speeds and is able to make the weld in the least amount of weld passes should be used. Automated welding should be employed whenever possible as automated techniques are often capable of depositing accurate amounts of weld metal at extremely high speeds. Fortunately, with modern arc welding processes, it is often possible to use high welding speeds, which help fight distortion (46).

The use of welding sequences or backstep welding may act to minimize distortion. The backstep technique allows for the general welding progression to be in one direction, but enables the depositing of smaller section of weld in the opposite direction. This provides the ability to use prior welds as a locking effect for successive weld deposits (46).

Whenever possible, welds should be performed from the center outward on a joint or structure. Wherever possible, successive passes should be done on alternate sides on double-sided and multi-pass welding. An even better method to control distortion is to weld both sides of a double-sided weld simultaneously (46).

Components may be preset so they will move during welding to the desired shape or position after weld shrinkage. This is a method of using the shrinkage stresses during the manufacturing process. Through experimentation, the correct amount of offset can be determined which compensates for weld shrinkage. Then, only the size of the weld need be controlled to produce consistently aligned welded components (46).

The use of restraints such as clamps, jigs and fixtures, and back-to-back assemblies should be considered. Locking the weld in place, with clamps fixed to a solid base plate to hold the weld in position and prevent movement during welding, is a common method of combating distortion. Another method is to place two welds back-to-back and clamp them tightly together. The welding is completed on both assemblies and allowed to cool before the clamps are removed. Pre-bending can be combined with this technique by inserting spacers at suitable positions between the assemblies before clamping and welding (46).

#### 6.3.6. Grinding

Grinding is done on the welded joint to remove excess material and create a smooth surface. Grinding machines remove material from the work piece by abrasion, which generates enormous amounts of heat. In some instances, a coolant must be incorporated to cool the work piece so that it does not overheat. Again, as in the case with welding, excessive overheating will weaken the base material.

#### 6.3.7. Finishing

Finishing, which includes grinding, may be used 1) to improve appearance, adhesion or wettability, solderability, corrosion resistance, tarnish resistance, chemical resistance, wear resistance, and hardness, 2) to modify electrical conductivity, 3) to remove burrs and other surface flaws, and 4) to control the surface friction. The most common example of finishing for aluminum welds is peening<sup>†</sup>.

Hand peening may be performed after welding to help relieve the tensile stresses that develop in the weld metal and surrounding base metal on cooling. The level of reduction in tensile stress is only minimal and occurs on or near to the weld surface. Peening will induce a higher hardness into the weld and this is something that should be avoided. For this reason peening is not normally accepted by the majority of codes, standards or specifications (e.g., ASME B31.3 §328.5.1 (d)). Any peening that is carried out

on a weld should have been carried out on the weld procedure qualification test piece.

The welding procedure qualification test piece replicates all of the essential variables that will be used in production welding. If the weld is peened during the qualification of a welding procedure, the subsequent mechanical testing of the procedure qualification test piece will demonstrate the mechanical properties of the weld. These mechanical properties must, as a minimum, match the mechanical properties specified in the weld procedure. If they do not, the procedure has failed, and the welding procedure is not acceptable for use in production welding. Peening should only be carried out on a production weld where the procedure test piece has been peened.

#### 6.3.8. Inspection / Testing

ABS has stringent standards that welds are held to. The inspections are mostly visual, and testing is non-destructive. The following are the ABS standards for inspection and testing (12).

- *Appearance* – Welds shall be free of cracks, incomplete fusion and burn-through. Visible arc-strikes on welds and the adjacent base metal are not allowed and shall not exceed 1 mm (1/32 in.) in depth after removal. Weld spatter greater in diameter than 1 mm (1/32 in.) is not acceptable. Gouge marks, nicks and other fabrication scars in the weld inspection zone shall not exceed the requirements for undercut. Weld surfaces shall be free of slag to the extent that there is no interference with visual or other required nondestructive test. Crater pits are considered acceptable, provided 1) the area contains no cracks, 2) the root concavity and convexity limits are not exceeded, and 3) the minimum weld thickness requirements are met.
- *Melt-through*<sup>†</sup> – Melt-through and repaired burn-through areas are acceptable, provided the areas do not contain cracks, crevices, excessive oxidation or globules, and provided that the root convexity and concavity limits are not exceeded.
- *Suckback*<sup>†</sup> – Suckback is unacceptable in a weld or base metal when it occurs as a sharp notch or where the depth reduces the weld thickness below the minimum base metal thickness.
- *Undercut* – The minimum undercut shall be 1 mm (1/32 in.) or 10% of the adjacent base metal thickness, whichever is less. For base metal thickness 12 mm (0.5 in.) and greater, undercut from 1 mm (1/32 in.) to 1.5 mm (1/16 in.) is allowed if the accumulated length of undercut does not exceed 15% of the joint length or 300 mm (12 in.), whichever is less.
- *Dye Penetrant*<sup>†</sup> – Dye penetrant inspection is to be used when investigating the outer surface of welds or may be

considered for use as a check of intermediate weld passes, such as root passes and also to check back-chipped, ground or gouged joints prior to depositing subsequent passes. Any dye penetrant used is to be thoroughly removed from the area before re-welding. Dye penetrant is not to be used where complete removal of the dye penetrant materials cannot be assured. Dye penetrant is to be used before peening if specified.

- *Radiographic or Ultrasonic Inspection* – Radiographic or ultrasonic inspection or both may be used when the overall soundness of the weld cross section is to be evaluated. Finished welding is to be sound and thoroughly fused throughout its cross section and to the base material. Production welds are to be crack free. Other discontinuities, such as incomplete fusion or incomplete penetration, slag, and porosity, are only to be present to the degree permitted by the pertinent inspection standard. The procedures and standards for radiographic and ultrasonic inspection is to be in accordance with the Bureau’s separately issued publication, *Guide for Nondestructive Inspection of Hull Welds (12)*, or other approved acceptance standards.
- *Weld Plugs or Samples* – The practice of taking weld plugs or samples by machining or cutting from the welded structure is not recommended and is to be considered only in the absence of other suitable inspection methods and is to be subject to the special approval of the Surveyor. When such weld plugs or samples are removed from the welded structure, the holes or cavities formed are to be properly prepared and welded, using a suitable welding procedure approved by ABS and as established for the original joint.

#### 6.3.9. Bimetallic Transition Inserts

Arc welding is not a reliable method for joining aluminum to other materials and introduces galvanic corrosion. Very brittle intermetallic compounds form when metals such as steel, copper, or titanium are directly arc welded to aluminum. To avoid the problems associated with arc welding these dissimilar materials, it is necessary to use special fabrication techniques to isolate the other metal from the molten aluminum during the arc welding process. The most common method of facilitating the joining of an aluminum component to a steel component by arc welding is by using a bimetallic transition insert.

Bimetallic transition inserts are available commercially in combinations of aluminum to such other materials as carbon steel, stainless steel, copper, and titanium. These inserts are sections of material that are comprised of one part aluminum with another material already joined to the aluminum. The methods used for joining these dissimilar materials together and thus forming the bimetallic transition

are usually explosion welding, rolling, friction welding, flash welding, or hot pressure welding.

The arc welding of these steel-aluminum transition inserts in production can be performed by the normal arc welding methods such as gas metal arc welding or gas tungsten arc welding. One side of the insert is welded steel to steel and the other aluminum to aluminum. Care should be taken to avoid overheating the inserts during welding, which may cause growth of brittle inter-metallic compounds at the interface of the two materials in the transition insert. It is good practice to perform the aluminum-to-aluminum weld first. Proceeding in this manner can provide a larger heatsink when the steel-to-steel welding is performed and help prevent the steel-aluminum interface from overheating.

Some manufacturers of these bimetallic inserts provide recommended procedures that suggest care should be taken to avoid heating the steel-aluminum bond zone above 600°F during welding. In addition, joint details are recommended for some applications that are designed to minimize the amount of heat directed toward the transition bond. Bimetallic transition inserts are offered in various thicknesses and are available in strip, plate, and tubular section. The bimetallic transition insert is a popular method of joining aluminum to steel and is often used for producing welded connections of excellent quality within structural applications. In the shipbuilding industry, where transition insert joints have become the standard means of welding aluminum superstructures and bulkheads to steel hulls, framing, and decks. This aluminum-to-steel weldability has given naval architects and shipbuilders the freedom to maximize the benefits of materials, the strength and economy of steel, combined with the lightweight and corrosion resistance of aluminum. Structural transition inserts for shipbuilding use are typically composed of 5xxx series aluminum bonded to low-carbon-manganese steel and must meet ABS and ASTM A264 Standard Specification for Stainless Chromium-Nickel Steel-Clad Plate, Sheet, and Strip (18), MIL-STD-1689 Fabrication, Welding, and Inspection of Ship Structures (130), NAVSEA Technical Publication T9074-AS-GIB-010/271, Nondestructive Testing Requirements for Metals (96).

#### 6.3.10. Design Requirements

There are multiple design considerations that must be taken into account in designing a welded joint. Critical welded joints must be very detailed to avoid excessive cost and over strengthening of the joint. The type of weld must be specified in critical joints including definition of length of weld, size, spacing, location and frequency (number of welds) and method. All of the important information about a weld is given in the standards drawings and is defined by ANSI/AWS A2.4-79 (36). Figure 15 shows a sample and a description of the notes.

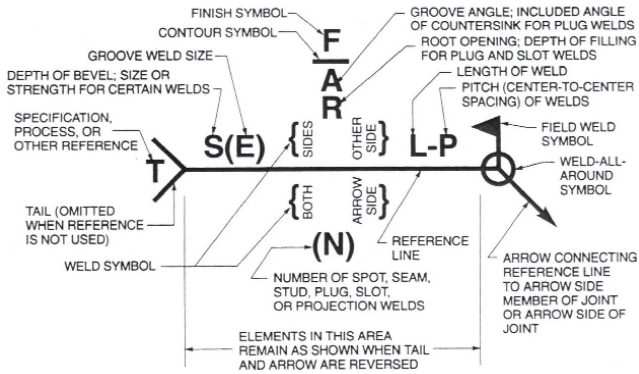

Figure 15. **Options for the Welding Symbol Commonly Used in Manufacturing (88)**

These factors that contribute to the type of weld are determined using the following attributes:

- *Material Thickness* – Optimum weld quality results when the work pieces being joined are approximately the same in thickness, thus allowing for equal weld penetration.
- *Necessary Weld Strength* – In theory, weld strength should be adequate to handle the stresses the assembly will see in service plus the desired safety factor. Yet overdesign of specified welds is common. A weld may be overdesigned to boost the strength of a thin sheet metal part (designed thin for cost saving), but final cost may surpass that of using heavier gauge metal in the first place. The metal forming supplier can often help determine the best welding option based on manufacturing capabilities and experience. A weld can never be stronger than the base metal. For welded butt joints, strength is usually equal to that of the base metal. For fillet welds, stresses are assumed to act in shear and weld strength depends on leg size, length of the weld, type of weld metal, and loading direction.
- *Cost of Weld* – Welding is such a versatile process that it is often the best way to produce sheet metal assemblies which must meet both strength and cosmetic requirements. However, compared to other joining processes, manual welding, particularly in smaller volumes, can be relatively expensive. As the volume of the product to be assembled increases, the process becomes competitive with alternate joining methods. High volume products can be very economically produced using dedicated fixturing and laser, semiautomatic, or robotic welding techniques. The length and width of a weld can have a great effect on cost. By not specifying size, length and number of

welds, and by avoiding fillets that are welded all around, the size of a weld can be limited, reducing cost. Additionally, choosing weld locations and orientations that more directly resist primary service stresses can reduce weld size. Again, this reduces labor and material costs.

- *Finish and Splatter* – Designers should be careful to specify when weld splatter is not allowed. Parts that are to be painted or otherwise finished after welding may require a secondary grinding operation to smooth welds down to an acceptable level. Depending on finishing specifications, the cost of secondary grinding can easily equal or exceed the initial welding cost. When welding is done on a "face" or cosmetic panel, small dips or undercuts may appear. If this is visually unacceptable, grinding and polishing are needed. Surface finish should always be specified to reflect cosmetic requirements. This is particularly important when welding thick to thin material.
- *Finishing Considerations* – It is extremely important that the designer consider the effect of any welding on subsequent finishing operations. Welded assemblies to be painted should preferably be designed with hidden welds. If this is not possible, locate the welds for easy and economical grinding access. Grinding should be avoided in inside corners or on internal surfaces, as it requires special equipment and costly hand operations.

#### 6.3.11. Welder Certification

ABS must be satisfied that the welders and operators are proficient in the type of work which they are called upon to perform, either through requiring any or all of the tests or through due consideration of the system of employment, training, apprenticeship, plant testing, inspection.

Tests are based on the material thicknesses and welding processes involved. Qualification of welders for a particular alloy may be acceptable for qualification of the welder for other aluminum alloys. Separate qualification tests are to be made for the gas metal arc and gas tungsten arc processes. The tests are referred to by numbers Q1, Q2, Q3, Q4, and Q5. Alternatively, upon the request of the employer, the welder may be qualified by use of radiography, provided that the complete particulars of the equipment available and the procedures are demonstrated to be satisfactory. Test assemblies for either mechanical testing or radiographic examination are to be prepared according to material thickness and welding. Table 10 describes the test available.

**Table 10. Welder Qualification Tests Descriptions**

Construction Material	Welding Position		
	Flat, Horizontal, Vertical and Overhead	Flat and Vertical	Flat Position Only
On material of limited thickness 19.1 mm (3/4 in.) or less <sup>1</sup>	Test No. Q1 in vertical and overhead positions	Test No. Q1 in vertical position	Test No. Q1 in flat position
On material of unlimited thickness <sup>1,2</sup>	Test No. Q2 in vertical and horizontal positions	Test No. Q2 in vertical position	Test No. Q2 in flat position
On piping or tubing <sup>3</sup>	Test No. Q3 in horizontal and vertical positions	Test No. Q3 in horizontal and vertical fixed positions	Test No. Q3 in horizontal rolled position
For tack welders	Test No. Q5 in vertical and overhead positions	Test No. Q5 in vertical position	

Notes:

1. Where the maximum thickness of material on which a welder may have occasion to work throughout the period governed by a test is indeterminate, the Surveyor may, if desired, require the welder to qualify under unlimited thickness requirements.
2. Where the maximum plate thickness to be welded is between 19.1 mm (3/4 in.) and 38.1 mm (1-1/2 in.) qualification Test No. Q2 may, with the permission of the Surveyor, be conducted on plate of maximum thickness involved.
3. Welding operators qualified under the requirements of Test No. Q4 will be considered as qualified to make welds governed by Tests Nos. Q1 and Q2. Welding operators qualified to weld on plate in the vertical position may be permitted to weld on pipe in the horizontal rolled position.

#### 6.4. Adhesives

The use of adhesives is another form of joining aluminum to either aluminum, other metals, or to fiber reinforced plastics (FRP). A widely-used adhesive that has been tested in a marine environment is methacrylate adhesive, also known as methamethacrylate (MMA). The use of adhesives has become more popular because of their ease of use and the elimination of welding-induced distortion. With the elimination of welding-induced distortion, the use of a thinner plate thickness may be possible. One disadvantage of using adhesives is their lack of strength in a fire. Because of this disadvantage, a greater amount of fire protection insulation is required to protect the adhesive joints than would be required for welded joints (115).

#### 6.5. Structural Details

Structural details describe specific structural features at particular locations; typically, the structural details are specified to smoothly transfer the stresses in one structural member to another. For example, a structural detail must be specified at the intersection of a transverse frame and a longitudinal stiffener.

Jordan and Cochran (77) conducted a survey of 50 different vessels of various types in order to obtain a “database” of structural details currently in use on steel vessels. This study was followed by a follow-on study conducted by Jordan and Knight (78) which surveyed 36 additional vessels. (Jordan and Knight also published a design guide

for structural details.) Although the ships surveyed were steel vessels, often the same details are used in aluminum vessels.

There is a range of structural details and typically several apply to each particular scenario. It is, therefore, necessary to choose the best detail for the scenario under consideration. The criteria should include each of the following considerations; however, the weight of each will depend on the location of the detail and the stresses, deformations, etc. that affect the location:

- Does the detail provide a smooth stress transition, if applicable?
- What stress concentrations are introduced to the structure by the detail? Stress concentrations may be acceptable if the detail is located in a region with low stress.
- Does the detail provide resistance to fatigue? This is especially important for aluminum vessels, which are more sensitive to fatigue. Sielski (115) evaluates the different details in each category to provide a fatigue assessment in accordance with Eurocode 9 (60).
- How difficult is the detail to fabricate?
- Is there sufficient access to weld the detail?

#### 6.5.1. Joining Aluminum Structure to Steel

There are several methods of joining aluminum to steel structure: using bimetallic pads / plates (see Section 6.3.9), bolting (see Section 6.2), or riveting (see Section 6.1).



## 7. Ship Loading

Ships are the largest mobile structures built by man, and both their size and the requirement for mobility exert strong influences on the structural arrangement and design. In contrast to many land-based structures, the structural components of a ship are frequently designed to perform a multiplicity of functions in addition to that of providing the structural integrity of the ship. For instance, the shell plating serves not only as a principle strength member but also as a watertight envelope. Internal strength members also serve dual functions such as bulkheads that contribute substantially to the strength of the hull and may also serve as watertight compartments (84).

Ship structural loads can be divided into three separate categories: basic loads, sea environment and operational environment (see Figure 16). These loads can also be categorized into four other categories: static, low-frequency dynamic, high-frequency dynamic and impact (in Figure 16 these categories have been color coded). In Figure 16 the category “Docking” is multicolored due to the fact that when the ship is dry docked it is considered a static load and a tugboat that would be used during docking maneuvers is considered an impact load.

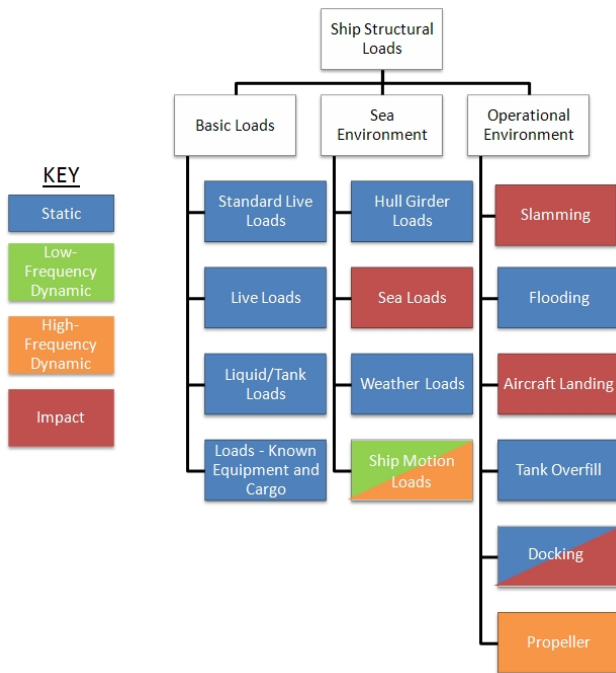

Figure 16. Ship Structural Loads

An important characteristic of a ship structure is the composition of stiffened plate panels, some of which are plane, normal, or curved, which make up the side, bottom shell, the decks, and bulkheads. This is in contrast to where

many structural instances would normally call for beams, columns, or trusses. Therefore, much more effort should be expended in ship structural analysis concerned with predicting the loading and interactions of stiffened panels. These interactions are analyzed and summarized into a model called the hull girder model (83).

### 7.1. Major Loads on the Hull Girder Model

There are four loads that must be accounted in the analysis of the ship’s hull girder model in the structural design process (84):

- Static Loads
- Dynamic Loads (Low Frequency)
- Dynamic Loads (High Frequency)
- Impact Loads

#### 7.1.1. Static Loads

Static loads are loads on a ship that slowly vary with time. These changes are due to a variety of factors and are accounted for when the total ship weight changes, the loading and unloading occurs, consumption of fuel, or modifications to the ship itself. Static loads are influenced by (84):

- The weight of the ship and its contents
- Static buoyancy of the ship when at rest or moving
- Thermal loads resulting from non-linear temperature gradients within the hull
- Concentrated loads caused by dry-docking or grounding

The static loads consist of two main forces: the buoyancy forces and gravitational forces. To determine gravitational loads:

$$f = mg \quad (31)$$

Where:

- f = force applied
- m = mass of the object
- g = gravitational acceleration

To determine buoyancy force, the designer must integrate over the length of the design to determine the buoyant force per unit length whose magnitude is given by  $\rho gA$ , where  $\rho$  is the mass density, or mass per unit volume, and A is the immersed sectional area.

#### 7.1.2. Low-Frequency Dynamic Loads

Low-frequency dynamic loads are loads that vary with time in periods that range from a few seconds to several minutes. Since these loads occur at such low frequencies, there is no

appreciable resonant amplification in the structure. The loads mostly originate from the action of waves and therefore are always changing with time. They are broken down into (84):

- Wave-induced pressure variations
- Hull pressure variations caused by oscillatory ship motions
- Inertial reactions resulting from acceleration of the mass of the ship and its contents

To determine low frequency dynamic loads, the designer should perform a linear load and response deformation analysis, which is calculated using the frequency response function  $H(\omega)$ , or the RAO, and also using the impulse response function  $h(t)$  which form a Fourier pair:

$$h(t) = \frac{1}{2\pi} \int_{-\infty}^{+\infty} H(\omega) e^{i\omega t} d\omega \quad (32)$$

And

$$H(\omega) = \int_{-\infty}^{+\infty} h(t) e^{-i\omega t} dt \quad (33)$$

### 7.1.3. High-Frequency Dynamic Loads

These loads are time varying of sufficiently high frequency that may induce a vibratory response in the ship structure. Some of these exciting loads may be small in magnitude but may have a resonant amplification which may give rise to large stresses and deflections. Examples of such dynamic loads are the following (84):

- Hydrodynamic loads induced by propulsive devices
- Loads imparted to the hull by reciprocating or unbalanced rotary machinery
- Hydrostatic loads resulting from the interaction of appendages with the flow past the ship
- Wave induced loads, primarily due to short waves whose frequency of encounter overlaps the lower natural frequencies of hull vibration and which, therefore, may excite appreciable resonant response, termed springing†

To determine high frequency dynamic loads, the designer should perform a linear load and response deformation analysis, which is calculated using the frequency response function  $H(\omega)$ , or the RAO, and also using the impulse response function  $h(t)$  which form a Fourier pair (see Equations (32) and (33)).

### 7.1.3.1. Shaft Line / Propeller Loads

One of the largest contributors to hull structure vibrations is imparted by the propeller and shaft line. Any unbalance in the weight of the propeller, line shaft and in the individual blades of the propeller will cause vibrations.

Blade rate excitation is caused by the uneven flow of water over the blades of the propeller, and this is also a source of vibration.

To minimize the vibration caused by the shaft line and propellers it is necessary to ensure that the line shaft is straight under operating conditions. ABS has software to optimize the alignment of the line shaft and guidance notes regarding line shaft alignment (115).

### 7.1.4. Impact Loads

Impact loads are dynamic loads resulting from slamming or waves impacting on parts of the hull structure. Impact loads may induce transient hull vibrations called whipping (84).

An impact load is defined as having a duration of load application that is less than one-half of the fundamental natural period of vibration of the load bearing member. The exact determination of stress is difficult, but impact stress can be approximated by applying the conservation of kinetic and strain energy:

$$s_i = s_s \sqrt{\frac{W_i}{W_b} \left( \frac{3W_i}{3W_i + W_b} \right)} \quad (34)$$

Where:

- $s_i$  = impact stress, force/length<sup>2</sup>
- $s_s$  = static stress, force/length<sup>2</sup>
- =  $W/A$  for an axial load
- =  $M_y/I$  for a beam in bending,  $T_r/I_p$  for a circular shaft in torsion, etc.
- $W_i$  = weight of impacting mass, force
- $W_b$  = weight of impacted object, force

### 7.1.5. Other Sources of Operational Ship Loads

In addition to the other load categories, there may also be specialized operational loads that part or all of the structure may have to withstand; these may be the dominant loads on certain ships. They can be either static loads or dynamic loads (84).

#### 7.1.5.1. Tank Loads

Tank loads occur in the form of hydrostatic loading on the boundaries of tanks. The loads are typically expressed in terms of a head of seawater in feet or meters. For some

analyses, tank loads may partially or completely cancel pressure loading on the opposite face of the plating. For instance, a tank adjacent to shell plating may cancel seawater pressure loading on the outside of the shell. However, since the tank may not always be relied upon to be full, this load cancelation should not be included in strength analysis.

7.1.5.2. Live and Dead Loads

The term “live loads,” which is sometimes referred to as probabilistic loads or superloads, are the variable forces applied to the structure within the structure’s normal operation cycle and not including construction or environmental loads. Within this force group is (typically) deck loading resulting from personnel, cargo and material handling equipment, and minor equipment. The live load intensity should be varied based on the function of the space. Table 11 lists typical live load intensities.

**Table 11. Typical Live Loading Intensities (95)**

Type of Compartment	Live Loading Intensity (lbs/ft <sup>2</sup> )
Living and control spaces, offices and passages, main deck and above	75
Living spaces below main deck	100
Offices and control spaces below main deck	150
Shop spaces	200
Storerooms	300 <sup>1</sup>
Weather portions of main deck and 01 Level	250 <sup>2</sup>

Notes:

1. Or stowage weight, whichever is greater
2. Or maximum vehicle operating load (including helicopter operational loads), whichever is greater

Dead loads or intrinsic loads are due to the weight of the structure itself including construction and environmental load (e.g., wind, etc.). In most cases a conservative estimate is sufficient for calculating dead loads as a careful calculation of each structural component is not necessary.

To determine maximum stress caused by live and dead loads, it would appear as though the correct method is to add them together. This will result in a massive overestimate. The combination needs to be accounted for carefully because the two sets of loads hardly, if ever, occur at the exact same point. If they occur at the exact same point, then the two loads can be added together. Since the maximum stress in a structure for live and dead loads hardly ever acts at the same place, it is the case that the overall increase is a fraction of the addition of the two maximum

stresses and in a completely different position than either the live or dead load maximum.

7.1.5.3. Equipment / Point Loading

One level of detail greater than live loading is to perform analyses with the actual loading numbers included. This is recommended for large or concentrated loads. Calculations using actual loading numbers are especially important for plating and smaller structural members rather than longitudinal girders and major frames. To determine point loading, a series of equations must be used:

$$Q = \frac{PE}{\sigma_y^2} \tag{35}$$

Where:

- P = the pressure exerted by the equipment, Force/Area
- E = Elastic modulus of the plate material
- $\sigma_y$  = yield stress of the material

Also:

$$\beta = \frac{b_s}{t} \sqrt{\frac{\sigma_y}{E}} \tag{36}$$

Where:

- $b_s$  = stiffener spacing
- t = plate thickness
- a/ $b_s$  = aspect ratio of plate area which is the ratio of the length of unsupported plate area

From these equations, point loads can be calculated to a determined permanent set  $w_p$ . Using:

$$\frac{w_p}{b_s \sqrt{\frac{\sigma_y}{E}}} = \text{dimensionless design variable} \tag{37}$$

A series of design curves are used to interpolate the four equations. Figure 17 shows an example of these plots for a uniformly loaded plate with the value of Equation (37) set to 0.2. Hughes (73) provides additional plots for additional values of Equation (37).

Using all the determinate factors, a point on the chart is identified and used to determine a design value.

#### 7.1.5.4. Sea Loads

When sailing in heavy seas, a ship can experience very large heave and pitch motions causing the forebody to completely emerge from the water. In the accompanying downward fall and thrust back into the water, the ship can generate considerable impact forces. The loads occur in the flat areas of the forward part of the ship and are strongly correlated to loading conditions with a low forward draft. This affects both local and global bending behaviors and slamming of the hull girder model with generation of vibration (84).

Other sea loads are static equivalent to heads of seawater and are uniform pressures. They represent the effects of sea and wave actions on the shell, the weather deck, and the lower parts of the superstructure or deckhouse. They account for passing waves, heel, pitching resulting in bow submergence, green seas on the weather deck and wave slapping loads (84).

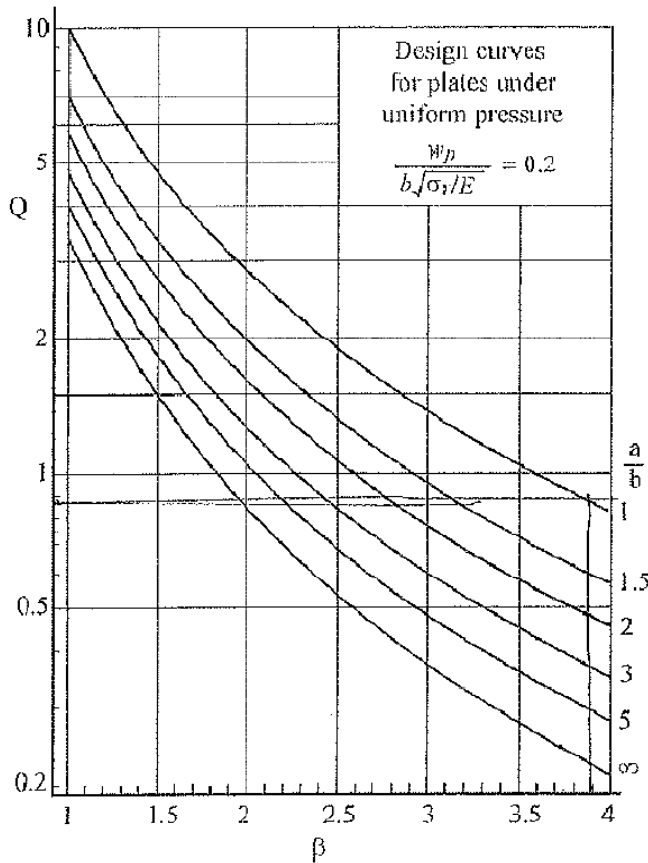

Figure 17. Loaded Plate Design Curves (73)

These loads are either static-equivalent heads of seawater or uniform pressures, representing the effects of sea and wave action on the shell, weatherdeck, and lower parts of the superstructure. They account for passing waves, heel, pitching resulting in bow submergence, and wave slap loads.

Wave slap loads are generally assumed to be 500 psf minimum. For inclined surfaces, the following assumptions are usually made:

- Sponson loads with medium height:
  - 1600 psf in the forward one-third length
  - 1000 psf in the after two-thirds length
- High sponsons: 500 psf
- Bow flare regions: 1600 psf

For low sponsons, the loads may be significantly higher, up to 7200 psf.

#### 7.1.5.5. Weather / Ice Loads

To account for wind loading on ship structure and exposed systems/equipment, they shall be designed to withstand a wind loading of 30 pounds per square foot (lb/ft<sup>2</sup>). For ship structure this applies to the projected area with no reduction for vertical members because of heel (96).

To account for snow and ice loading, the ship structure shall be designed for snow and ice loading of 7.5 lb/ft<sup>2</sup>. Exposed systems/equipment shall be designed to start and operate properly when covered with an ice load of 4.5 lb/ft<sup>2</sup> (96).

Ship supporting structure and foundations shall be designed for a load transmitted as a result of a wave slap of 500 pounds per square inch acting on the projected area of that portion of equipment and machinery, mounted on the weather deck that is located beneath a line established for the hydrostatic head specified for weather deck design (96).

#### 7.1.5.6. Ship Motion Loads

Sea conditions generate ship motions and produce dynamic loads. These forces are customarily grouped as resulting from storm sea conditions or moderate sea conditions (96).

The design process is primarily concerned with storm sea conditions. The ship motion amplitudes and periods for both sea conditions are specific to each individual ship design and loading factors are ordinarily only calculated and applied only for these two sea conditions. It is important to know that the basic load used in calculating ship motion factors consists of only dead and no stowage loads. Ship motion loads can be determined using equations found in Appendix A of Section 302 of MIL-STD-1399 (129) (96).

#### 7.1.5.7. Flooding

Flooding causes extreme cases of hydrostatic loading. Flooding loads are critical to bulkheads and decks in the vital spaces in the lower hull areas (96). The loss of stability from flooding may be due in part to the free surface effect. Water accumulating in the hull usually drains to the bilges, lowering the centre of gravity and actually increasing the metacentric height; however, it is causing increased

loading because of the redistribution of buoyancy and weight forces on the ship that was not designed to handle these loads. This assumes the ship remains completely stationary and upright. However, once the ship is inclined to any degree (e.g., due to a wave strike), the fluid in the bilge moves to the low side. This results in a list creating an even more severe loading condition. Flooding is not always caused by accidental loads such as grounding or collision, but may be caused by overfilling of tanks. This makes the loading condition a significant condition that must be considered in design. Flooding cases are designed to the yield and collapse loads of the structure (124).

#### 7.1.5.8. Accidental Loads

When discussing loads that occur from grounding and collisions, the general approach is to define the dynamics of the accident itself in order to determine the trajectories of the units involved. In general, the dynamics should be equated into six degrees of freedom accounting for the numerous forces acting during the event.

The governing equations for the problems are given by the conservation of momentum and of energy. Within this framework, time domain simulations can evaluate the magnitude of contact forces and the energy, which is absorbed by the structure deformation. These quantities, together with the response characteristics of the structure allow for an evaluation of damage penetration (energy absorption capacity). To determine accidental loads see Section 7.1.4.

Grounding in general, has its dominant forces develop at the first impact with the ground, followed by friction and the weight of the ship. The energy is dissipated in the deformation of the lower part of the bow, dissipated in friction of the same area against the ground, spent in deformation work against the ground, and converted into gravitational potential energy (work done against the raising the weight of the ship vertically). The final position governs the magnitude of the vertical reaction force and the distribution of the shear and bending moments that are generated on the hull girder (83). To determine the loading of a grounding incident, use:

$$P_{\max} = \frac{2R_{\text{ground}}}{l_g b_{\text{avg}}} \quad (38)$$

Where:

- $P_{\max}$  = maximum grounding pressure, lton/ft<sup>2</sup>
- $R_{\text{ground}}$  = ground reaction, lton
- $l_g$  = grounded length, feet
- $b_{\text{avg}}$  = average breadth of contact area over grounded length, feet

#### 7.1.5.9. Aircraft

Landing aircraft on a ship's deck is one of the most complex operations and loading situations known. Both vehicles are moving in 6-degrees of freedom that operate in uncontrollable and often unpredictable environments. Aircraft usually will land in their designated landing zones; but because they may need to land outside the landing zone during special circumstances, the entire flight deck should be analyzed for landing loads.

Aircraft handling decks are exposed to two types of loads, in addition to those in the standard design of all decks. These loads are landing and parking loads imposed by the aircraft which operate on the deck. Landing loads are imparted to the deck upon touchdown of the aircraft. Parking loads are imparted during the remaining time the aircraft is in contact with the ship.

The landing and parking orientation of the aircraft with respect to the ship affects the loading on the deck structure and determines how individual structural members are analyzed. It is assumed during the design that a longitudinal or athwartships landing produces greater loading than angle orientations.

The following areas should be analyzed:

- Center of landing area
- Outboard and aft of the landing area
- Handling area between the landing area and the hangar
- Hangar

Each of the above locations should be analyzed for the following load cases as applicable (landing cases do not need to be analyzed in the hangar):

- Landing, longitudinal orientation
- Landing, athwartship location
- Parking, storm sea condition, longitudinal orientation
- Parking, storm sea condition, athwartships orientation
- Parking, moderate sea condition, longitudinal orientation
- Parking, moderate sea condition, longitudinal orientation

Tie downs and chains will need to be including in parking situations as restraining forces (95).

See section 7.1.5.3 for general equations to calculate the point loading. For detailed analysis techniques, use DDS 130-2 (95).

#### 7.1.5.10. Docking, Mooring, and Dry-Docking

A docked or moored vessel has many loads on it from external sources. Loads are exerted from external actions on the mooring system and from there to the local supporting structure. The main contributors to the loads are wind, waves, and current.

The wind force is directed in the direction of the wind with the magnitude depending on wind speed and the exposed geometry of the ship.

The current exerts loads on the immersed part of the ship and will cause a similar action to that of the wind.

Linear wave excitation has a sinusoidal time dependence. If the ship motions in the wave direction are not constrained, as in an anchoring situation, the ship motion will have an excitation similar to the time dependence and a very small lag time. This causes only a small load on the mooring system. If the ship is constrained, significant loads are created.

Once the total force on the ship is quantified, the tension in the mooring system can be derived by the force decomposition, taking into account the angle formed with the external forces (83).

To calculate docking loads, the actions should be characterized in terms of two force components, one in the longitudinal  $F_{WiL}$  and  $F_{WiT}$ , and a moment  $M_{Wiz}$  about the vertical axis, all applied at the center of gravity.

$$F_{WiL,T} = \frac{1}{2} C_{FL,T}(\varphi_{Wi}) \varphi A_{wi} V_{wi}^2 \quad (39)$$

$$M_{Wiz} = \frac{1}{2} C_{Mz}(\varphi_{Wi}) \varphi_{wi} L V_{wi}^2 \quad (40)$$

Where:

- $\varphi_{wi}$  = the angle formed by the direction of the acting forces (wind, current, etc.)
- $C_{mz}(\varphi_{wi})$  } coefficients depending on the shape of
- $C_{FL}(\varphi_{wi})$  } the exposed part of the ship and on angle
- $C_{FT}(\varphi_{wi})$  }  $\varphi_{wi}$
- $A_{wi}$  = the reference area of surface of the ship exposed to wind, (usually the area on the cross section)
- $V_{wi}$  = acting force speed

Ship designs must include considerations for dry docking. The ship's positions are determined well in advance and may also require special internal structure to stiffen while in dry-dock. The vessel may also be ballasted or trimmed to aid in the operation (124). Generally, it should be assumed that the block loading in dry docking should be 20 ton/ft<sup>2</sup> on the bottom structure.

#### 7.1.5.11. Point Loads from Tugs, Pilot Boats, Piers, etc.

Point loads caused by tugboats, pilot boats, piers, etc. should be carefully placed against the ship's frame. This is to avoid damage to the unsupported plating between the frames and thus avoiding damage to the ship's overall structure.

Loads due to boat handling are not quantified in general terms because they depend too much upon the criteria of the specific case at hand. Criteria must be derived on an individual basis depending on the requirements of the specific design. In general though they are consistent with a point load. See section 7.5.1.3, Equipment/Point Loading for general equations to calculate the point loading.

#### 7.2. Response of the Hull Girder Model to Loads

In designing a hull girder model for a ship, the model is analyzed as a static condition with the hull balanced on a standard wave. The characteristics of the wave are based upon the ship characteristics. They are defined as (84):

- Wave Length: LBP
- Wave Height: 1.1 x  $\sqrt{LBP}$
- Wave Profile: Trochoidal

And load cases are usually assumed as (84):

- The crest of the standard wave centered amidships (hogging)
- The trough of a standard wave centered amidships (sagging)

Usually, the calm water or still water case is investigated, but is rarely useful. Special cases of wave lengths, wave heights, and wave centers may also be investigated, but since they are only special cases, they provide little value for comparison to other designs (84).

The hull girder model's geometric arrangement and resulting stress or deflection response patterns are divided into three reaction components which are labeled as primary, secondary, and tertiary (84).

- Primary response is the response of the entire hull when bending and twisting as a beam, under the external longitudinal distribution of vertical, lateral, and twisting loads.

- Secondary responses comprise the stress and deflection of a single panel of stiffened plating (e.g., the panel of the bottom structure contained between two adjacent transverse bulkheads). The loading of the panel is normal to its plane, and the boundaries of the secondary panel are usually formed by secondary panels (side shell and bulkheads). Boundary edge loads are also present due to primary bending of the hull.
- Tertiary response describes the out-of-plane deflection and associated stress of an individual panel of plating. The loading is normal to the panel, and its boundaries are formed by the stiffeners of the secondary panel of which it is a part. Boundary edge loads also exist as a result of primary hull bending.

To perform the hull girder beam model calculation, shear force ( $V(x_1)$ ) and bending moment ( $M(x_1)$ ) must be calculated for any location,  $x_1$  (84).

$V(x_1)$  is obtained as the integral of the load curve:

$$V(x_1) = \int_0^{x_1} [b(x) - w(x)] dx \quad (41)$$

Where:

$b(x)$  = buoyancy per unit length

$w(x)$  = weight per unit length

The bending moment at location  $x_1$ ,  $M(x_1)$ , is the integral of the shear curve (84):

$$M(x_1) = \int_0^{x_1} [V(x)] dx \quad (42)$$

Where:

$V(x)$  = shear force, as defined in Equation (41)

Figure 18 shows the results of these equations plotted against a buoyancy and load curve.

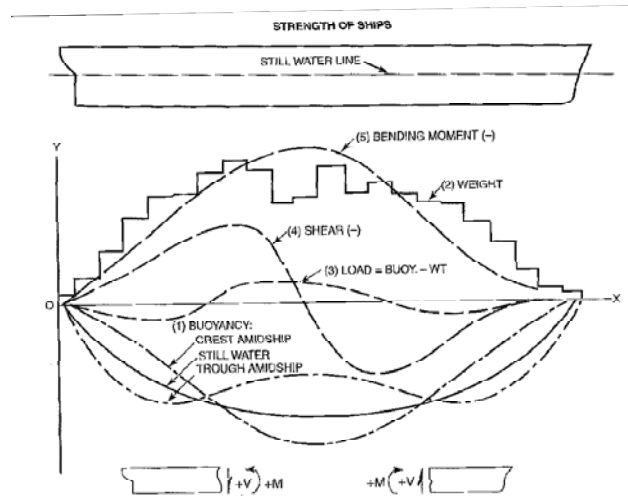

Figure 18. **Typical Vessel Shear / Bending Moment Diagram**

Great care must be exercised in these calculations especially when it comes to sign conventions of positive and negative loads. The conditions of static equilibrium require that the shear force and bending moment both equal zero at both ends of the ship.

### 7.3. Dominant Load Parameters

For high speed craft, *Dominant Load Parameters* (DLP) (which refer to a ship motion or wave load effect that represent the extreme loading of a craft) are required to effectively construct a finite element structural analysis.

To develop the load cases for a finite element analysis a list of DLP are developed. This includes select motion and load effect parameters. Other loads, such as those due to wave impacts on the bow and stern, flare and bottom slamming, wet-deck slamming (multi-hulls) and vibration effects on local structural strength, have to be treated separately. Load cases are defined by a combination of craft loading conditions, a set of global motion and load effect parameters set forth in terms of each of the DLPs, other load components accompanying the DLPs and an equivalent wave system for the specified DLP.

Calculations are made using the spectral analysis based approach, which by definition relies on the use of Response Amplitude Operators (RAOs). Each RAO is calculated for regular waves of unit amplitude for a range of wave frequencies and wave headings that will be given below. The model of the hull should include the masses of all equipment, vehicles and supporting structure. There is also to be sufficient compatibility between the hydrodynamic and structural models so that the application of fluid

pressures onto the finite element mesh of the structural model can be done appropriately.

Computations of the wave-induced motions and loads are carried out through the application of seakeeping analysis codes utilizing three-dimensional potential flow based diffraction-radiation theory. Computation of the hydrodynamic pressures should take account of, as a minimum, all six degree-of-freedom rigid-body motions of the hull. These codes are based either on linear (small) wave and motion amplitude assumptions or nonlinear (large) amplitude motion and wave formulations. The Rankine source panel method is recommended for solving the hydrodynamic boundary value problem. For each loading condition:

RAOs of all the selected DLPs are calculated. The RAOs represent the pertinent range of wave headings ( $\beta$ ), in increments not exceeding 15 degrees. A range of wave frequencies is considered based on the route-specific wave conditions. The nominal range is 0.2 rad/s to 1.8 rad/s in increments of 0.05 rad/s. The worst frequency-heading ( $\omega$ ,  $\beta$ ) combination is determined from an examination of the RAOs for each DLP. Only the heading  $\beta_{\max}$  and the wave frequency  $\omega_e$  at which the RAO of the DLP is a maximum, need to be used in DLA or direct analysis.

Extreme value analysis is performed for each DLP to determine the maximum values. An extreme value method that follows the so-called long-term approach is used. The use of a validated short-term extreme value approach, which is appropriate to the craft type and route specific environmental data, is also considered. The supplementary use of such a short-term approach to confirm or test the sensitivity of the long term based design values is recommended. The relevant value to be obtained from the long-term response analysis is the most probable extreme value (MPEV) having a probability of level of  $10^{-8}$  in terms of wave encounters.

The environmental condition is described by an appropriate sets of wave data. The wave parameters used in the analysis are selected and documented based on the conditions given in the craft specification. The values should be compatible with the stochastic response and extreme value prediction methods.

#### *7.4. Discussion of Aluminum Properties with Respect to Loading*

Aluminum alloys find use where the special attributes such as low density and high strength to weight ratio, corrosion resistance, and retention of toughness in low temperatures are of great value in the ship, developing a ship structure able to distribute the loads found in the ship's environment (124).

Aluminum alloys typically have an elastic modulus of 70 GPa, which is roughly one-third to that of steel and steel alloys. Therefore, for a given load, a component or unit made of an aluminum alloy will experience a greater elastic deformation than a steel part of the identical size and shape. Though there are aluminum alloys with somewhat higher tensile strengths than the commonly used kinds of steel, simply replacing a steel part with an aluminum alloy might lead to significant structural problems (83).

In general, stiffer and lighter designs can be achieved with aluminum alloys than is feasible with steels. For example, consider the bending of a thin-walled tube: the second moment of area is inversely related to the stress in the tube wall, i.e., stresses are lower for larger values. The second moment of area is proportional to the cube of the radius times the wall thickness, thus increasing the radius (and weight) by 26% will lead to a halving of the wall stress while maintaining similar strength (83).

The most important structural limitation of aluminum alloys is their lower fatigue strength compared to steel. Unlike steels, aluminum alloys have no well-defined fatigue limit, meaning that fatigue failure eventually occurs, under even very small cyclic loadings. In controlled laboratory conditions, steels display a fatigue limit, which is the stress amplitude below which no failure occurs. The metal does not continue to weaken with extended stress cycles. Aluminum alloys do not have this lower fatigue limit and will continue to weaken with continued stress cycles. Aluminum alloys are, therefore, sparsely used in parts that require high fatigue strength in the high cycle regime (83).

Fatigue characteristics must be improved to allow aluminum to become a better material option. The fatigue limitations of aluminum result from their as-welded properties. Improved welding methods (or eliminating welding by adhesive joining methods) can increase the fatigue allowable stresses for aluminum. For example, flush ground welding of aluminum increases the fatigue strength to two-thirds that of ordinary steel, resulting in a fifty-percent structural weight saving (82). For more detail on fatigue, see Section 1.

##### 7.4.1. Vibration

Although aluminum has one-third the elastic modulus of steel, it also has one-third the density; therefore, similar structures in aluminum and steel will have the same natural frequency of vibration if there is no other mass associated with the mode of vibration. Due to the reduced strength of aluminum, the structure designed for the same conditions will have greater stiffness due to additional structure and stiffening to increase the strength, and, therefore, the frequency of vibration will be greatly increased. This increase in frequency will be offset if the structure has a large mass associated with it, and aluminum structure in



such situations may have to be made stiffer to prevent vibration problems from occurring. Aluminum may be less tolerant of vibration if there are stress concentrations in the vibrating structure that could become points of fatigue crack initiation (115).

As the design becomes better defined, it is possible to perform vibration analysis to identify any potential problems. The fundamental flexural and torsional frequencies of the vibration of the ship's hull may be estimated by empirical formulas; however, these methods often yield inconsistent results. More refined predictions of hull natural frequencies and mode shapes can be determined by the application of existing theories and related computer programs (124). The natural frequencies corresponding to the two-noded vertical bending modes of conventional ship hulls can be estimated with reasonable accuracy using Kumai's formula is:

$$N_{2v} = 3.07 \times 10^6 \sqrt{\frac{I_H}{\Delta_i LBP^3}} \frac{\text{cycles}}{\text{minute}} \quad (43)$$

Where:

- $I_H$  = moment of inertia,  $m^4$
- $\Delta_i$  = virtual displacement, including added mass of water, in tons
- =  $\left(1.2 + \frac{1}{3} \cdot \frac{B_{amid}}{T_m}\right) \Delta$
- $\Delta$  = ship displacement, in tons
- LBP = length between perpendiculars, in m
- $B_{amid}$  = breadth amidships, in m
- $T_m$  = mean draft, in m

### 7.5. High Speed Loads

The classification of the high speed ship will ultimately determine the loads that are calculated and the structure required to resist those loads. This section will describe the general design process that all of the classification societies follow.

#### 7.5.1. Design Process

There are four kinds of loads that act on vessels: static, dynamic high frequency, dynamic low frequency and impact loads. The static loads are the global loads on the

vessel's hull that create hogging/sagging moments, lateral bending moments and torsion. The static loads and their determination are described in Section 7.1.1.

The impact loads are the static and dynamic pressures acting on the local plating and stiffeners. The impact loads are calculated first to determine structural plating and scantlings. From these scantlings, the hull strength can be checked to ensure that the entire hull structure can resist the static, dynamic high frequency and dynamic low frequency loads. The design process for determining impact loads and the scantlings to resist them in high speed craft involves identifying/calculating the following items:

- 1) Determining design conditions (sea state and speed)
- 2) Vertical accelerations
- 3) Bottom pressures
- 4) Required plating thickness
- 5) Required structural scantlings

For sample calculations of vertical accelerations, bottom pressures, required plating thickness and required structural scantlings for a notional monohull per each classification described herein, see Ship Structure Committee Report 439 (122). This manual will focus on describing the general method of calculating vertical accelerations, bottom pressures, required plating thickness and required structural scantlings for high-speed vessels.

#### 7.5.1.1. Sea States

Waves are created by local wind acting on the surface and/or by distant or old storms creating a swell that is superimposed along with the local waves. Wind itself is highly variable in direction and pressure. With these inputs for generating waves, their amplitudes and wavelengths are highly variable. Thus, effects of waves on hull structure are difficult to determine with accuracy.

Waves are classified into sea states depending on their height. The sea state's severity is described by the significant wave height. This is the wave height that best describes the overall sea appearance. The significant wave height can be the 1/3 highest waves encountered in one-hundred instances or 1/10 highest waves encountered or any fraction. The requirements of the particular classification society determine which significant wave height is utilized (80). Figure 19 provides a table of sea states.

SEA STATE <sup>1</sup>	FULLY RISEN SEAS <sup>2</sup>										WIND			APPEARANCE OF THE SEA <sup>5</sup>
	WAVE HEIGHT (feet)										WIND <sup>3</sup>			
	AVERAGE	SIGNIFICANT (avg. of 1/3 highest)	AVG. OF 1/10 HIGHEST	SIGNIFICANT RANGE	T <sub>max.</sub> (based on energy of spectrum, sec.)	T (average period, sec.)	L (avg. wave length, ft.)	WIND SPEED (knots)	MINIMUM FETCH (nm)	MINIMUM DURATION (hrs)	BEAUFORT NUMBER <sup>4</sup>	WIND DESCRIPTION	WIND SPEED (knots)	
0	0	0	0	-	-	-	-	-	-	-	0	CALM	<1	Sea like a mirror.
	0.05	0.08	0.10	up to 1.2 sec.	0.7	0.5	0.83	2	5	0.3	1	LIGHT AIRS	1-3	Ripples with the appearance of scales are formed, but without foam crests.
1	0.18	0.29	0.37	0.4-2.8	2.0	1.4	6.7	5	8	0.7	2	LIGHT BREEZE	4-6	Small wavelets, still short but more pronounced; crests have glassy appearance and do not break.
	0.6	1.0	1.2	0.8-5.0	3.4	2.4	20	8.5	9.8	1.7	3	GENTLE BREEZE	7-10	Large wavelets. Crests begin to break. Foam of glassy appearance. Perhaps scattered white horses.
2	0.88	1.4	1.8	1.0-6.0	4.0	2.9	27	10	10	2.4	4	MODERATE BREEZE	11-16	Small waves, becoming longer; fairly frequent white horses.
	1.4	2.2	2.8	1.0-7.0	4.8	3.4	40	12	18	3.8				
3	1.8	2.9	3.7	1.4-7.6	5.4	3.9	52	13.5	24	4.8	5	FRESH BREEZE	17-21	Moderate waves, taking a more pronounced long form; many white horses are formed. (Chance of some spray.)
	2.0	3.3	4.2	1.5-7.8	5.6	4.0	59	14	28	5.2				
4	2.9	4.6	5.8	2.0-8.8	6.5	4.6	71	16	40	6.6	6	STRONG BREEZE	22-27	Large waves begin to form; the white foam crests are more extensive everywhere. (Probably some spray.)
	3.8	6.1	7.8	2.5-10.0	7.2	5.1	90	18	55	8.3				
5	4.3	6.9	8.7	2.8-10.6	7.7	5.4	99	19	65	9.2	7	MODERATE GALE	28-33	Sea heaps up and white foam from breaking waves begins to be blown in streaks along the direction of the wind. Spindrift begins.
	5.0	8.0	10	3.0-11.1	8.1	5.7	111	20	75	10				
6	6.4	10	13	3.4-12.2	8.9	6.3	134	22	100	12	8	FRESH GALE	34-40	Moderately high waves of greater length; edges of crests break into spindrift. The foam is blown in well-marked streaks along the direction of the wind.
	7.9	12	16	3.7-13.5	9.7	6.8	160	24	130	14				
7	8.2	13	17	3.8-13.6	9.9	7.0	164	24.5	140	15	9	STRONG GALE	41-47	High waves. Dense streaks of foam along the direction of the wind. Sea begins to roll. Spray may affect visibility.
	9.6	15	20	4.0-14.5	10.5	7.4	188	26	180	17				
8	11	18	23	4.5-15.5	11.3	7.9	212	28	230	20	10	WHOLE GALE <sup>6</sup>	48-55	Very high waves with long overhanging crests. The resulting foam in great patches is blown in dense white streaks along the direction of the wind. On the whole the surface of the sea takes a white appearance. The rolling of the sea becomes heavy and shock like. Visibility is affected.
	14	22	28	4.7-16.7	12.1	8.6	250	30	280	23				
9	14	23	29	4.8-17.0	12.4	8.7	258	30.5	290	24	11	STORM <sup>6</sup>	56-63	Exceptionally high waves. (Small and medium-sized ships might for a long time be lost to view behind the waves.) The sea is completely covered with long white patches of foam lying along the direction of the wind. Everywhere the edges of the wave crests are blown into froth. Visibility affected.
	16	26	33	5.0-17.5	12.9	9.1	285	32	340	27				
10	19	30	38	5.5-18.5	13.6	9.7	322	34	420	30	12	HURRICANE <sup>6</sup>	64-71	The air filled with foam and spray. Sea completely white with driving spray; visibility very seriously affected.
	21	35	44	5.8-19.7	14.5	10.3	363	36	500	34				
11	23	37	46.7	6.0-20.5	14.9	10.5	376	37	530	37				
	25	40	50	6.2-20.8	15.4	10.7	392	38	600	38				
12	28	45	58	6.5-21.7	16.1	11.4	444	40	710	42				
	31	50	64	7.0-23.0	17.0	12.0	492	42	830	47				
13	36	58	73	7.0-24.2	17.7	12.5	534	44	960	52				
	40	64	81	7.0-25.0	18.6	13.1	590	46	1110	57				
14	44	71	90	7.5-26.0	19.4	13.8	650	48	1250	63				
	49	78	99	7.5-27.0	20.2	14.3	700	50	1420	69				
15	52	83	106	8.0-28.2	20.8	14.7	736	51.5	1560	73				
	54	87	110	8.0-28.5	21.0	14.8	750	52	1610	75				
16	59	95	121	8.0-29.5	21.8	15.4	810	54	1800	81				
	64	103	130	8.5-31.0	22.6	16.3	910	56	2100	88				
17	73	116	148	10.0-32.0	24	17.0	985	59.5	2500	101				
	>80	>128	>164	10-(35)	(26)	(18)	-	>64	-	-				

Figure 19. Sea States (98)

High speed vessels are typically built to withstand a certain sea state and speed combination typically defined as the operating envelope and are only meant to operate up to that speed in that sea state. Selection of the sea state is dependent on the vessel owner's requirements. Since the vessel is designed for service in a specific sea state and speed, the vessel owner must ensure that if the operating envelope is expanded that the vessel's structure is adequate to meet the requirements of that the operating envelope.

Figure 20 shows the operating envelopes of various high speed 1000-ton ship types.

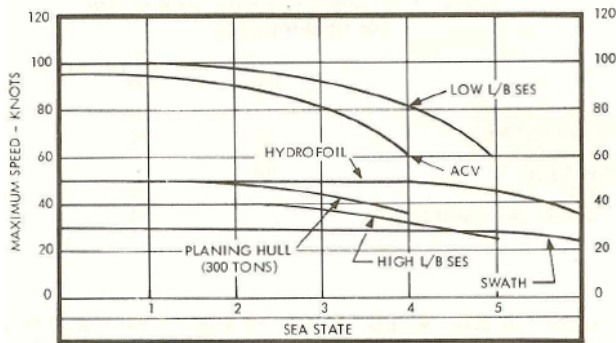

Figure 20. **Comparative Operating Envelopes of 1000-ton Ships (58)**

For ABS HSC and ABS HSN, there is a table for the significant wave heights requirements depending on the service of the vessel and the minimum is 1/12 the waterline length of the vessel (9) (10).

The DNV HSLC significant wave height (DNV HSLC defines the significant wave height as the wave coefficient) is dependent on length and service classification. For vessels less than or equal to 328 ft in length and unrestricted service, Equation (44) is utilized:

$$C_w = 0.08LWL \quad (44)$$

Where:

$C_w$  = wave coefficient  
 $LWL$  = waterline length of the vessel in m

For vessels less than or equal to 328 ft in length and unrestricted service, Equation (45) is utilized:

$$C_w = 6+0.02LWL \quad (45)$$

Then, regardless of waterline length, the wave coefficient is then multiplied by a factor depending on the service of the vessel to attain the wave coefficient ( $C_w$ ).

The wave coefficient is then utilized in the DNV HSLC for calculating the vertical accelerations (55).

### 7.5.1.2. Speed

The maximum speed a vessel will be able to attain is dependent on the hull-form, weight and the installed power of the vessel. The installed power of the vessel determines the speed in calm water; service speed determination includes a calculation of added resistance in the design sea state. The process of determining resistance of a high speed vessel between the preplanning and planning phase has aspects that are not clearly defined by calculation methods. There are two methods of calculating added resistance of a high speed vessel. The first method, which is often referred to as the Savitsky method, uses geometric characteristics of the hull to define the resistance of the transom in the preplanning stage and the second uses strip theory to define the resistance once the vessel is planing. Both methods are documented in references (110) and (71), respectively. These two methods can provide widely differing results. The reason for the uncertainty is that the transition from preplanning to planing produces the most resistance the vessel will encounter, and the method to estimate this resistance is not clearly defined. This creates uncertainty in the calculation in the overall speed of the vessel (80).

### 7.5.1.3. Vertical Accelerations

The vertical accelerations are dependent on the sea states that a vessel will encounter and the speed the vessel will be travelling through that sea state. Once the sea state requirement and the maximum speed are defined, the vertical accelerations can be determined.

The average impact acceleration at the center of gravity of a monohull vessel can be determined from the following equation:

$$N_z = 0.0104 \left( \frac{H_1}{b} + 0.084 \right) \frac{\tau}{4} \dots \left( \frac{5}{3} - \frac{\beta}{30} \right) \left( \frac{V_k}{\sqrt{LWL}} \right)^2 \frac{LWL/b}{C_\Delta} \quad (46)$$

Where:

$\Delta_{LT}$	=	full load displacement, long tons
$N_Z$	=	vertical acceleration at center of gravity, G's
$H_{1/3}$	=	significant wave height in an irregular sea state, ft
$b$	=	beam, ft
$\tau$	=	trim angle of planning area, deg
$\beta$	=	deadrise angle, deg
$V_K$	=	speed, knots
LWL	=	Length along the waterline
$C_\Delta$	=	static beam loading coefficient = $\nabla / B_{PX}^3$
$\nabla$	=	vessel displaced volume, cu. ft
$B_{PX}$	=	maximum chine beam, ft

Before utilizing any equation regarding the calculations of vertical accelerations, the designer must know the origins from which the equations were derived and the range of their applicability. Table 12 defines the range of applicability for Equation (46).

**Table 12. Range of Applicability for Vertical Acceleration Parameters (110)**

Parameter	Range
$\Delta_{LT}/(0.01L)^3$	100 - 250
L/b	3 - 5
Trim, deg	3 - 7
Deadrise, deg	10 - 30
$H_{1/3}/b$	0.2 - 0.7
$V_K/\sqrt{L}$	2 - 6

Notes:

1. See symbol definitions following Equation (46)

The use of historical data can assist in reducing the uncertainty in vertical accelerations. As more high-speed vessels have been built, the data available from their respective designs have been made available. This data can aid the designer in calculating vertical accelerations from similar vessels. See reference (51) for the calculation of vertical accelerations for various ship types utilizing ABS HSNC rules. Additionally, model tests can further reduce the uncertainty in vertical accelerations.

#### 7.5.1.4. Slamming Pressures – Monohulls

The magnitude and shape of the slamming pressure distribution on a given hull-form is dependent on the sea state, speed and vertical acceleration of the vessel. For monohulls, the majority of peak slamming pressures occur forward of amidships and aft of the bow. This area is called the reference area†. The reference area is roughly one-third of the water plane area.

The reference area for monohulls can be defined with this expression from (119):

$$A_R = \frac{3600\Delta_{LT}}{d} \quad (47)$$

Where:

$A_R$	=	impact reference area in square inches
$\Delta_{LT}$	=	full load displacement in long tons
$d$	=	full load static draft in feet

The average slamming pressure over the reference area can be determined from the following equation:

$$\bar{p} = \frac{\text{impact induced load}}{A_R} \quad (48)$$

$$= \frac{2240\Delta_{LT} N_Z}{A_R} \quad (49)$$

Where:

$\bar{p}$	=	average slamming pressure over reference area in pounds per square inch
$\Delta_{LT}$	=	full load displacement, long tons
$A_R$	=	impact reference area, square feet
$N_Z$	=	vertical acceleration

The maximum pressure over the impact reference area can be described by:

$$P_M = \frac{\bar{p}}{0.14} \quad (50)$$

Where:

$P_M$	=	maximum pressure over the impact reference area, pounds per square inch
$\bar{p}$	=	average slamming pressure over reference area in pounds per square inch

The structural design area ( $A_D$ ) is determined by the plating panel area or, for supporting structure, it is the area that the supporting structure reinforces between larger supporting members. The pressure reduction coefficient ( $K_D$ ) is determined from a graph of the design area divided by the reference area (see Figure 21). The longitudinal pressure distribution factor ( $F$ ) is also determined from a graph dependent on the longitudinal location of the structural design area (see Figure 22).

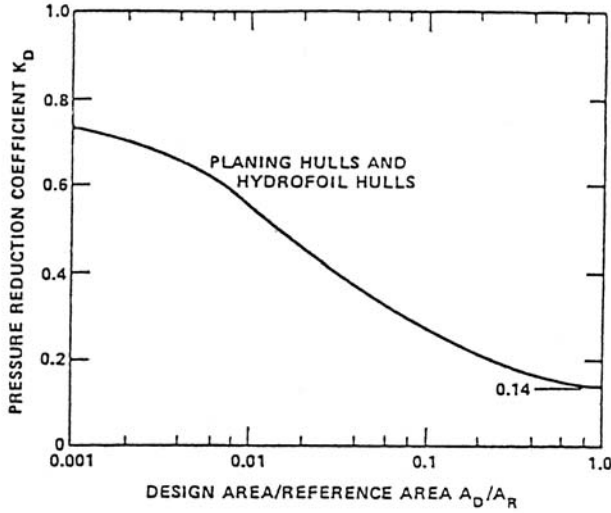

Figure 21. **Pressure Reduction Coefficient ( $K_D$ ) for Planing Hulls and Hydrofoil Hulls (3)**

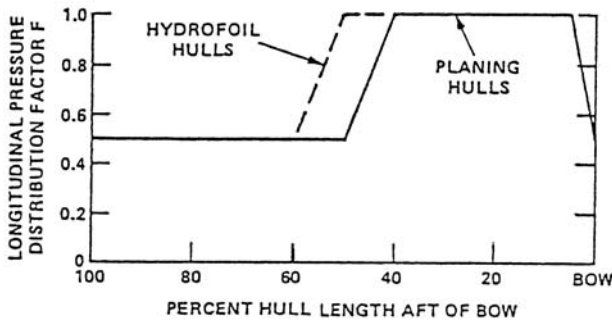

Figure 22. **Longitudinal Pressure Distribution Factor ( $F$ ) for Planing Hulls and Hydrofoil Hulls (3)**

Then, utilizing  $K_D$  and  $F$  the uniform static design pressure ( $P_D$ ) can be determined for the given plate or supporting structure by the following equation:

$$P_D = FK_D P_M \quad (51)$$

Where:

- $F$  = longitudinal pressure distribution factor (see Figure 22)
- $K_D$  = pressure reduction coefficient (see Figure 21)
- $P_M$  = maximum pressure over the impact reference area (see Equation (50))

#### 7.5.1.5. Slamming Pressures – Multihulls, SES, SWATH, & ACV

The wet deck is the cross structure that connects the hulls of a multi-hull vessel. Wet deck slamming only occurs in

multi-hull designs. The underside of the wet deck is likely to be subject to significant slamming.

For surface effect ships (SES), SWATH vessels and air cushioned vehicles (ACV) the reference area can be calculated with equation (52). In comparison to the monohull reference area, the reference area on SES, SWATH and ACV is located more at or near the bow or the forward area of the wet deck.

$$A_R = \frac{12.6(W_L)^{2/3}}{(1 + r_x)^{2/3}} \quad (52)$$

Where:

- 12.6 = an empirically derived coefficient
- $A_R$  = impact reference area, square feet
- $W_L$  = gross weight of the vessel, pounds
- $r_x$  = ratio of the distance from the center of gravity to the most forward point of impact on the bow or the bow of the wet deck divided by the radius of gyration in pitch

The average slamming pressure over the reference area can be determined from Equation (54):

$$\bar{P} = \frac{\text{impact induced load}}{A_R} \quad (53)$$

$$= \frac{W_L N_Z}{A_R} \quad (54)$$

Where:

- $\bar{P}$  = average slamming pressure over reference area, pounds per square inch
- $A_R$  = impact reference area, square feet
- $N_Z$  = vertical acceleration
- $W_L$  = gross weight of the vessel, pounds

The maximum pressure over the impact reference area can be described using Equation (55) or (56):

Unprotected Structure:

$$P_M = \frac{\bar{P}}{0.09} \quad (55)$$

Structure Behind Seals:

$$P_M = \frac{\bar{P}}{0.18} \quad (56)$$

Where:

$\bar{P}$  = average slamming pressure over reference area, pounds per square inch

The structural design area ( $A_D$ ) is determined by the plating panel area or, for supporting structure, it is the area that the supporting structure reinforces. The pressure reduction coefficient ( $K_D$ ) is determined from a graph of the design area divided by the reference area (see Figure 23). The longitudinal pressure distribution factor ( $F$ ) is also determined from a graph dependent on the longitudinal location of the structural design area (see Figure 24).

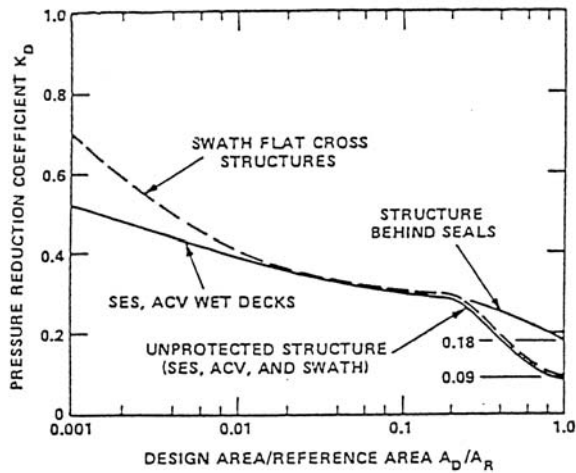

Figure 23. **Pressure Reduction Coefficient ( $K_D$ ) for SES, ACV and SWATH Vessels (3)**

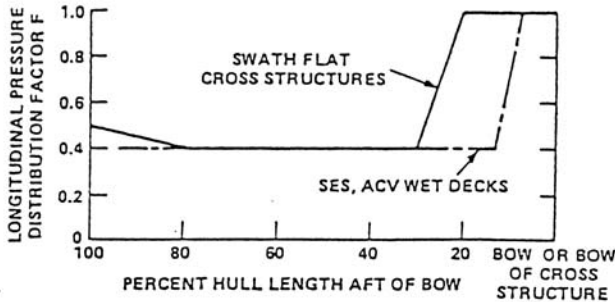

Figure 24. **Longitudinal Pressure Distribution Factor ( $F$ ) for SES, ACV and SWATH Vessels (3)**

Then utilizing  $K_D$  and  $F$  the uniform static design pressure ( $P_D$ ) can be determined for the given plate or supporting structure by Equation (57):

$$P_D = CFK_D P_M \quad (57)$$

Where:

- $C$  = 0.88 for unprotected structures
- $C$  = 0.44 for structure behind seals
- $F$  = longitudinal pressure distribution factor (see Figure 22)
- $K_D$  = pressure reduction coefficient (see Figure 23)
- $P_M$  = maximum slamming pressure over the impact reference area (see Equations (55) and (56))

#### 7.5.1.6. Required Plating Thicknesses and Structural Scantlings

The required plating thicknesses and scantlings are derived from the bottom pressures, geometry of the panel and the allowable stress. For a given structure the allowable stress is the material welded yield strength multiplied by a safety factor dependent on the location on the hull. Guidance for the selection of allowable stresses can be found in reference (68).

The spacing of longitudinals (in inches) can be determined from Equation (58):

$$s = t\sqrt{2\sigma/P_D} \quad (58)$$

Where:

- $t$  = required plating thickness
- $\sigma$  = allowable stress, pounds per inch
- $P_D$  = uniform static design pressure (see Equation (51) or (57))

The required section modulus ( $SM$ ) of a longitudinal can be found from Equation (59):

$$SM = (P_D s w_f^2)/12\sigma_f \quad (59)$$

Where:

- $P_D$  = uniform static design pressure (see Equation (51) or (57))
- $s$  = longitudinal spacing in inches (see Equation (58))
- $w_f$  = transverse frame spacing in inches
- $\sigma_f$  = allowable fatigue stress

For extreme localized loads to be distributed smoothly throughout the hull framing, the longitudinal continuity along the length of the vessel is suggested.

For transverse frames that are floating, the moment about transverse frames can be calculated from Equation (60):

$$M = k w_f P_D l_t^2 \quad (60)$$

Where:

- k = coefficient for beam equation
- w<sub>f</sub> = transverse frame spacing in inches
- P<sub>D</sub> = uniform static design pressure (see Equation (51) or (57))
- l<sub>t</sub> = effective length for transverse frames

To determine k:

$$k = \left( \frac{nw}{l_t} + \frac{l_t}{nw} \right)^2 \quad (61)$$

Where:

- w = width of plate
- n = structural node

Transverse frames that are attached to longitudinals and that are not welded to the shell plating are considered to be floating. For transverse frames that are welded to shell plating the variable “k” is dropped from Equation (60). The variable “k” can be developed for a fixed ended beam subjected to point loads (134).

The required section modulus of a transverse frame can be found from:

$$SM = M/\sigma \quad (62)$$

Where:

- M = Moment about the transverse frame (see Equation (60))
- σ = allowable stress, pounds per inch

#### 7.4.5 Machinery-to-Hull Interface Issues

For high-speed vessels, the propulsion machinery must be compact, lightweight, fuel efficient (to limit fuel storage) and transmit high levels of power (82). Propulsion machinery should be supported and secured by substantial girders, with stiffeners supported against tripping and supported at bulkheads (9).

Propulsion machinery foundations are subject to significant cyclic loads over the vessel’s life. Detailed structural

analysis of these foundations and supporting structure is essential to ensure that the working stress values do not exceed an acceptable fatigue stress. This type of analysis should include the cumulative effect of low cycle steering and reversing loads and high cycle blade pass frequencies (40). For a detailed reference regarding the calculation of and compatibility of the machinery and their foundation with the hull see (48).

The manufacturer’s recommendations should be carefully considered when designing propulsion engine foundations. The foundations are to be constructed to withstand the loads imparted by the equipment they support under the worst intended operating conditions. Foundations and supporting structure should prevent misalignment, deflection, or vibration, which would interfere with the operation of the propulsion machinery. Where main engine girders are part of the longitudinal strength of the craft, there should be continuity of strength and transition to smaller longitudinal structure (10).

Caution should be taken when determining the type of connections between the machinery and the hull. The use of dissimilar metals should be avoided in order to prevent the potential for galvanic corrosion (see Section 11.1.7). If connection points must utilize dissimilar metals, corrosion control methods should be considered (see Section 11.2).

## 8. Ultimate Strength of Ship Structure

Avoiding structural failure is the main goal of all structural designs and to achieve this goal, designers must be aware of all limit states, failure modes, and methods to predict their occurrence. From the viewpoint of structural design, there have been outlined four main limit states (83):

- Service limit state which corresponds to a situation where the structure can no longer provide service for which it was conceived. They typically lead to aesthetic, functional or maintenance problems, but not collapse.
- Ultimate limit state corresponds to collapse or failure, including grounding and collision.
- Fatigue limit state is considered a type of service limit state.
- Accidental limit states.

Ship structural failure may be the result of numerous reasons, and the degree or severity of the failure may vary from minor aesthetic degradation to complete loss of the ship. The three major failure loads are defined as (83):

- Tensile or compressive yield of the material
- Compressive instability (buckling)
- Fracture that includes ductile tensile rupture, low-cycle fatigue and brittle fracture

In general, it is imperative to differentiate service, ultimate, fatigue, and accidental limit states because the safety factors associated with each limit state is widely different.

The ultimate strength of the hull girder model is a composite of the ultimate strength characteristic of all of the structural components. The ultimate collapse behavior of the individual member is alone a complex subject not amendable to a simple analytic description (84).

### 8.1. Hull Girder Bending / Torsion

Ultimate hull girder bending strength relates to the maximum load the hull girder can support before collapse. These loads induce vertical and horizontal bending moments, torsional moment, vertical and shear forces and axial force. For usual seagoing vessels, axial forces can be neglected. Since maximum shear forces and maximum bending moment do not occur in the same place, ultimate hull girder strength should be evaluated at different locations and for a range of bending moments and shear forces. The ultimate bending moment ( $M_u$ ) refers to a combined vertical and horizontal bending moments ( $M_v$ ,  $M_h$ ) not being considered; the ultimate transverse shear forces ( $V_v$ ,  $V_h$ ) not being considered. Then the ultimate bending moment only corresponds to one of the feasible loading cases that cause hull girder collapse (83).

To determine maximum stillwater bending moments and shearing forces in the early design phases, the following equations are used:

$$M_{sw} = C_s LBP^{2.5} B (C_B + 0.5) \quad (63)$$

And

$$F_{sw} = 5.0 M_{sw} / LBP \quad (64)$$

Where:

$$\begin{aligned} M_{sw} &= \text{stillwater bending moment, in ton-m (ton-ft)} \\ F_{sw} &= \text{maximum hull-girder shearing force in stillwater, in tons} \\ C_s &= \begin{cases} \left[0.618 + \frac{110-LBP}{462}\right] 10^{-2} & 61 \leq LBP \leq 110m \\ \left[0.312 + \frac{360-LBP}{2990}\right] 10^{-3} & 200 \leq LBP \leq 360ft \\ \left[0.564 + \frac{360-LBP}{462}\right] 10^{-2} & 110 \leq LBP \leq 160m \\ \left[0.285 + \frac{525-LBP}{6100}\right] 10^{-3} & 360 \leq LBP \leq 525ft \\ \left[0.544 + \frac{210-LBP}{2500}\right] 10^{-2} & 160 \leq LBP \leq 210m \\ \left[0.275 + \frac{690-LBP}{16400}\right] 10^{-3} & 525 \leq LBP \leq 690ft \\ [0.544] 10^{-2} & 210 \leq LBP \leq 250m \\ [0.275] 10^{-3} & 690 \leq LBP \leq 820ft \\ \left[0.618 + \frac{LBP-250}{1786}\right] 10^{-2} & 250 \leq LBP \leq 427m \\ \left[0.275 + \frac{LBP-820}{11600}\right] 10^{-3} & 820 \leq LBP \leq 1400m \end{cases} \\ LBP &= \text{length between perpendiculars, in m(ft)} \\ B &= \text{breadth of vessel, in m(ft)} \\ C_B &= \text{block coefficient at summer load waterline, not to be taken as less than 0.64} \end{aligned}$$

Although torsion is not usually an important factor for design of most ships, it does result in significant additional stresses on ships. These warping stresses can be evaluated by beam analysis, which takes into account the twisting and warping deflections (83). Torsion is determined using the following differential equations:

$$E\Gamma\theta'''(x) - G_{sm}J_{tor}\theta'(x) = -T_m(x) \quad (65)$$

And

$$u(x, s_{cont}) = 2\theta'(x)\omega(s_{cont}) \quad (66)$$



Where

$u$	=	torsional displacement at the origin of the coordinate $s$
$\omega$	=	sectional area
$\Theta$	=	twist angle
$\Gamma$	=	Saint-Venant torsional constant
$E$	=	modulus of elasticity
$G_{sm}$	=	shear modulus of the material
$J_{tor}$	=	torsional constant of the section
$T_m$	=	total twist moment
$x$	=	longitudinal coordinate along vessel
$s_{cont}$	=	contour coordinate

### 8.2. Buckling

A ship stiffened plate structure can become unstable if either buckling or collapse occurs and may fail to perform its function. The phenomenon of buckling is normally divided into four categories, namely elastic buckling, elastic-plastic buckling, plastic buckling, and inelastic buckling (83).

The buckling and ultimate strength of the structure depend on a variety of different influential factors. These are geometric/material properties, loading characteristics, fabrication related imperfections, boundary conditions and local damage to corrosion, fatigue cracking and denting (83). To determine theoretical critical buckling stress in the elastic range is given by Bryan's formula, for rectangular plate to a compressive in-plane stress in one direction:

$$\sigma_c = k_c \frac{\pi^2 E}{12(1-\nu^2)} \left( \frac{t}{b_{pl}} \right)^2 \quad (67)$$

Where:

$E$	=	Elastic modulus
$\nu$	=	Poisson's ratio ( $\nu$ )
$t$	=	plate thickness
$b_{pl}$	=	plate length

$$k_c = \left( \frac{n}{AR} + \frac{AR}{n} \right)^2 \quad (68)$$

Where:

$AR$	=	plate aspect ratio
	=	$a/b_{pl}$
$n$	=	number of half waves of the deflected plate in the longitudinal direction

### 8.3. Whipping

In addition to the direct loads imposed on local structures, wave impacts may also excite high frequency hull-girder

vibrations, generally referred to as whipping (124). Whipping may result in vibratory stress intensities that are equal in magnitude to the wave induced low-frequency bending stresses (84). The hull will vibrate as a free-free beam in vertical, lateral, and torsional modes. Such vibration is generally not a problem in itself except for the additional fatigue cycles imposed on the hull structure. The frequency of the significant modes of hull vibration ranges from about 1 Hz to about 10 Hz for most vessels. If a significant portion of the vessel, such as a deckhouse or a mast has a natural frequency that resonates with one of these hull modes, then significant amplitudes of vibration can occur (115).

Two empirical methods are used for estimating the first vertical frequency for conventional steel hulls. The first of these is Schlick's empirical formula (115):

$$N_w = C \sqrt{\frac{I_H}{\Delta LBP^3}} \quad (69)$$

Where:

$N_w$	=	frequency in cycles per minute
$C$	=	empirical constant, varying between $1.28 \times 10^5$ to $1.57 \times 10^5$ , according to class of ship
$I_H$	=	area moment of inertia of the midship section in $\text{feet}^2 \text{inch}^2$
$\Delta$	=	displacement in long tons
$LBP$	=	length between perpendiculars in feet

A second method is Burrill's empirical formula (115):

$$N_w = \frac{\phi \sqrt{\frac{I_H}{\Delta LBP^3}}}{\sqrt{\left(1 + \frac{b}{2d}\right)(1+r)}} \quad (70)$$

Where the symbols are the same as in Equation (70) and:

$\phi$	=	empirical constant = $24 \times 10^5$
$I_H$	=	area moment of inertia of the midship section in $\text{feet}^2 \text{inch}^2$
$LBP$	=	length between perpendiculars in feet
$b$	=	beam of ship in feet
$d$	=	draft in feet
$r$	=	Lockwood Taylor's shear correction factor, which is defined using Equation (71):

$$r = \frac{3.5d^2(3a^3 + 9a^2 + 6a + 1.2)}{LBP^2(3a + 1)} \quad (71)$$

Where:

- a = b / d
- b = beam of ship in feet
- d = draft in feet
- LBP = length between perpendiculars

As both of the formulae were developed for steel hulls, the inertia of the hull girder,  $I_H$ , should be divided by 3 for aluminum. These formulae were developed for larger ships and are not necessarily applicable to smaller craft. For such vessels, especially multi-hulled craft, where the transverse bending (flapping) modes are important.

In most cases involving high speeds, the absolute motions or relative motions will be of such large amplitude that nonlinear calculations will be required. In catamarans, wet deck slam-induced global whipping effects of the hull are to be assessed using methods that account for coupling of the symmetric and anti-symmetric modes of responses. These calculations will require time-domain analysis methods (9).

#### 8.4. Deflections

The deflection of a ship's hull is estimated by the integration of the following equations:

For the bending moment,  $M$ , at section,  $x$ , all in consistent units:

$$EI_H \frac{d^2y}{dx^2} = M(x) \quad (72)$$

Where:

- y = deflection
- E = elastic modulus of material
- $I_H$  = moment of inertia of the hull at amidships

Or

$$M(x) = \int_0^x q(x) dx^2 \quad (73)$$

Where:

- $q(x)$  = Load per unit length

This may be written in terms of load per unit length,  $q(x)$ , as:

$$EI_H \frac{d^4y}{dx^4} = q(x) \quad (74)$$

Or:

$$\begin{aligned} \Delta q &= \text{change in load due to hull girder} \\ &\text{deflection} \\ &= \gamma \cdot y_x \cdot y_{tx} \end{aligned} \quad (75)$$

Where:

- $\gamma$  = density of water
- $y_x$  = breadth of the ship at waterline and at a length  $x$
- $y_{tx}$  = total deflection at  $x$  length along ship ( $y_s + y_b$ )

As calculated, the shear deflection becomes:

$$y_s = \int_0^x \frac{\lambda F}{G_{rig} A} dx \quad (76)$$

Where:

- $\lambda$  = a constant depending on the geometry of the cross-section and is given by Equation (78)
- F = Load
- $G_{rig}$  = Modulus of rigidity
- A = shear area

And the bending deflection is:

$$y_b = \int_0^x \frac{M(x)}{EI_H} dx^2 + \theta_o x + y_o \quad (77)$$

Where:

- $q(x)$  =  $(f(x) - p(x))$
- $f(x)$  = downward forces
- $p(x)$  = upward supporting forces
- $\theta_o$  = constant of integration
- $y_o$  = constant of integration

$$\lambda = \frac{1}{AF^2} \int_0^A \tau^2 dA \quad (78)$$

Where:

A = shear area  
F = load  
 $\tau$  = shear force

It can be seen that the deflection or the stiffness against bending, depends upon both geometry (moment of inertia, I) and elasticity (E). Thus, a reduction in hull depth or a change to a material such as aluminum (because E is approximately one-third that of steel) will reduce hull stiffness. An all-aluminum alloy hull would allow considerably more deflection than a conventional steel one having the same strength.

## 9. Fire

In order to prevent the spread of fire and the possible loss of life, fire protection is required on ships to safeguard the safety of the vessel. Insulation is required in most cases to prevent the spread of heat through steel bulkheads and decks. Requirements pertaining to aluminum structures are more extensive than those of steel. Unlike steel which can withstand high temperatures, aluminum must be protected from the heat to prevent melting. Although aluminum does not burn when exposed to ordinary fires, it does melt.

Prior to melting, as aluminum is heated it will lose tensile strength at an increasing rate. Figure 25 is an example of three different types of aluminum and the rate at which aluminum loses tensile strength as the temperature increases.

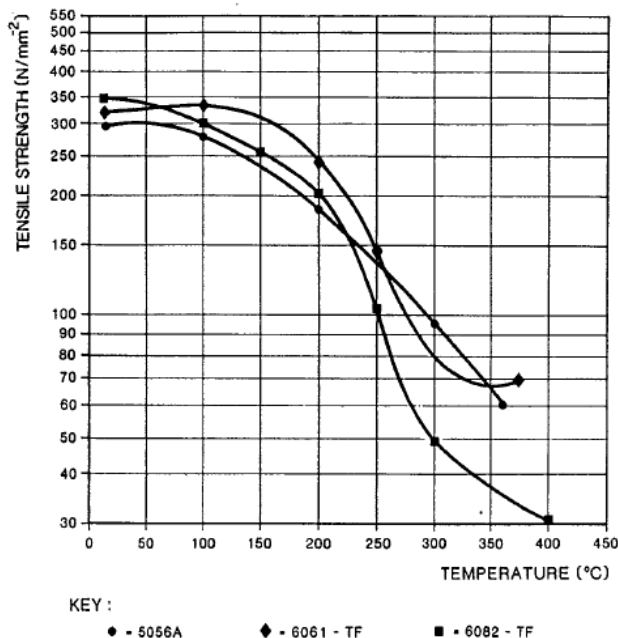

Figure 25. **Aluminum Tensile Strength Variation Versus Temperature**

Two design concerns for aluminum vessels are the various types of fire boundaries that must be considered during the arrangement of compartments and the insulation (and its weight) that protects the structure.

### 9.1. Regulatory Requirements

Fire and safety requirements for vessels operating in international waters are contained in SOLAS and in the IMO HSC. Policy guidance and accepted interpretations of structural fire protection regulations in SOLAS and the IMO HSC are provided by the U.S. Coast Guard Navigation and

Vessel Inspection Circular (NVIC) 9-97, Guide to Structural Fire Protection.

#### 9.1.1. SOLAS

The SOLAS requirements apply only to ships engaged in international voyages. The SOLAS requirements for fire protection include fire detection, fire containment and fire extinction<sup>16</sup>. The fire safety objectives include containing, controlling, and suppressing a fire or explosion to the compartment of origin, and to provide adequate and readily accessible means of escape for passengers and crew. To do this, the ship is divided into main horizontal and vertical thermal and structural boundaries. Accommodation spaces are separated from the remainder of the ship by such boundaries, and means of escape and access for firefighting are provided.

SOLAS contains three general classes of division, Class A, Class B, and Class C. Class A divisions are formed by bulkheads and decks constructed of steel or other equivalent materials, stiffened, can preventing the passage of smoke and flame for one hour, and are insulated. The insulation is intended to prevent the average temperature on the unexposed side from rising more than 140 °C (252 °F) above the original temperature, and the temperature at any one point shall not be more than 180 °C (324 °F) above the original temperature. There are four Class A divisions, A-60, A-30, A-15, and A-0, which prevent the temperature rise for 60, 30, 15, and 0 minutes, respectively.

Class B divisions are formed by bulkheads, decks, ceilings (overhead coverings), and linings. These must be constructed of non-combustible materials and be capable of preventing the passage of smoke and flame for one half-hour. The insulation is to prevent the average temperature on the unexposed side from rising more than 140 °C (252 °F) above the original temperature, and the temperature at any one point shall not be more than 225 °C (405 °F) above the original temperature. There are two Class B divisions, B-15 and B-0, which prevent the temperature rise for 15 and 0 minutes, respectively.

Class C divisions are constructed of non-combustible materials. Class C division do not need to meet requirements for prevention of passage of smoke or flame, or be insulated to prevent a temperature rise.

The requirements for the Class A, B, and C divisions are summarized in Table 13.

<sup>16</sup> SOLAS provides additional requirements, which are not covered in this section.

**Table 13. SOLAS Structural Division Classifications (75)**

Class / Subclass	Structure Types	Material	Maximum Average Rise in Temperature on Unexposed Side	Max Point Rise in Temperature on Unexposed Side	Minimum Protection Time <sup>1</sup>
A-60	Bulkheads, Decks	Steel or equivalent material <sup>2</sup> ; suitably stiffened; able to prevent passage of smoke or flame for 60 min	140°C (252°F)	180°C (324°F)	60
A-30					30
A-15					15
A-0					0
B-15	Bulkheads, Decks, Ceilings, Linings	Non-combustible material; able to prevent passage of smoke or flame at the end of 30 min test	140°C (252°F)	225°C (405°F)	15
B-0					0
C	Bulkheads, Decks, Ceilings, Linings	Non-combustible material	No Requirement	No Requirement	No Requirement

Notes:

1. The Minimum Protection Time is the minimum time that the bulkhead is able to keep the maximum average and maximum point temperatures below the requirement listed in the fourth and fifth columns.
2. An equivalent material is any non-combustible material that is capable of maintaining integrity the minimum exposure time, either bare or with the proper amount of insulation.

9.1.2. IMO HSC

The intent of the IMO HSC is to be a complete set of requirements for high-speed crafts, including equipment and conditions for operation and maintenance. The aim of the IMO HSC is to provide levels of safety which are equivalent to those contained in SOLAS and the International Convention on Load Lines, 1966. The IMO HSC includes very detailed requirements such that a high-speed craft deemed to be in compliance with the Code is therefore deemed to be in compliance with SOLAS chapters I to IV and regulation V(12) (shipborne navigational equipment).

The IMO HSC requires that aluminum structures be insulated so that the core temperature does not rise more than 180 °C (360 °F) above the ambient temperature during a fire test of the time specified for the type of space for which the structure forms the boundary.

The IMO HSC has requirements for the duration that bulkhead/decks must be able to provide an effective boundary between adjacent spaces. The classification of these spaces are:

1. Areas of major fire hazard – Type A
  - a. Machinery spaces
  - b. Ro-ro spaces
  - c. Galleys
  - d. Flammable liquid storerooms
2. Areas of moderate fire hazard – Type B
  - a. Auxiliary machinery space - containing internal combustion engines up to 110 kw, switchboards of aggregate capacity of exceeding 800 kw
  - b. Crew berthing areas

- c. Service Spaces
3. Areas of minor fire hazard – Type C
    - a. Auxiliary machinery spaces – containing refrigerating, A/C machinery and switchboards of aggregate capacity of 800 kw or less
    - b. Cargo spaces
    - c. Tanks, Voids
  4. Control stations – Type D
  5. Evacuation stations and escape routes – Type E
  6. Open spaces – Type F

Similar to SOLAS, the IMO HSC provides two tables; one for passenger vessels and one for cargo vessels, giving the times that bulkheads and decks must be able to provide protection between adjacent spaces. Table 14 shows the structural fire protection times for bulkheads and decks of passenger craft.

The IMO HSC identifies areas of major fire hazard, such as machinery spaces and flammable liquid storerooms that must be separated from each other by bulkheads and decks providing 60 minutes of protection. Areas of major fire hazard must be separated from areas of moderate fire hazard, such as auxiliary machinery spaces and crew accommodation spaces, by bulkheads and decks offering 60 minutes of fire protection, but the side having moderate fire hazard need only provide protection to an aluminum bulkhead for 30 minutes.

**Table 14. Structural Fire Protection Times for Separating Bulkheads and Decks of Passenger Craft (74)**

	A	B	C	D	E	F
Areas of major fire hazard A	60 1, 2	30 1	60 1, 8	60 1	60 1	60 1, 7, 9
Areas of moderate fire hazard B		30 2	30 8	60 3, 4	30 3	
Areas of minor fire hazard C			30 3, 8, 10	30 3, 4	30 3	
Control stations D				30 3, 4	30 3, 4	
Evacuation stations and escape routes E					30 3	
Open spaces F						

To design a deck or bulkhead to a certain structural fire protection according to IMO HSC you have to first identify the division that is being protected and the spaces adjacent to that division. Next determine the type of space on either side of the division. Then, identify an approved insulation that will provide the required protection for the given situation (A website for a listing of USCG approved insulation is given in Section 9.2).

### 9.1.3. USCG

For U.S.-flagged ships operating internationally, the U.S. Coast Guard has the responsibility of enforcing the SOLAS and IMO HSC requirements. All vessels operating in U.S. waters fall under the purview of the U.S. Coast Guard. Policy guidance and accepted interpretations for structural fire protection of the U.S. Coast Guard are published in NVIC 9-97.

The guidance and interpretations in NVIC 9-97 stem from the requirements of the IMO HSC for the structural protection of aluminum high speed vessels. The USCG does not have separate regulations for fire restricting materials and fire resisting divisions for high speed craft. The IMO HSC may be utilized to approve both SOLAS and domestic vessels.

### 9.1.4. US Navy

U.S. Navy ships require insulated fire zone bulkheads. The requirements are specified in the Part 1, Chapter 2 of the Naval Vessel Rules (NVR) of the American Bureau of Shipping. The NVR requirements are based on the IMO A.754(18) fire test procedure, modified to provide a hydrocarbon pool fire exposure based on the UL 1709 fire curve. Three classes of barriers result from that testing:

Class N-0, N-30 and N-60. Fire tests that are conducted by the U.S. Navy include an oil fire; whereas, the commercial standards are based on a wood fire, and so higher temperatures are achieved.

The NVR require that designated bulkheads and decks be designed to protect against structural failure and prevent the passage of fire and smoke when exposed to a hydrocarbon (class B) fire for a designated test period. They should prevent excessive temperature rise on the opposite side for the time period of 60 minutes or 30 minutes for Class N-60 and N-30. Class N-0 divisions should have no flaming on the unexposed face for a minimum of 30 minutes. The average temperature of the unexposed side should not be more than 139°C (250°F) above the original temperature, and the temperature at any one point, including any joint, should not rise more than 180°C (324°F) above the original temperature.

The following boundaries, if not part of a fire zone boundary are required to be Class N-0:

- Passageways and vertical accesses that are vital for egress.
- The boundary of contiguous vital spaces.
- Spaces containing flammable or combustible liquids or gases, oxidizers or other hazardous materials. Tanks shall be classification N-0 only for fire exposures outside the tank; insulation is not required inside the tank.
- Helicopter decks, flight decks and other exterior high fire risk surfaces. These N-0 boundaries shall prevent fire spread into the ship due to boundary failure.
- Weather boundaries adjoining helicopter decks, flight decks or other exterior high fire risk surfaces. These N-0 boundaries shall prevent fire spread into the ship due to boundary failure.
- Uptake and intake trunks and ventilation ducts from machinery spaces.
- Major watertight subdivisions.

Fire boundaries are not required on exterior (weather) bulkheads except for N-0 boundaries where needed to assure structural integrity of the hull girder, such as on critical stiffeners, to support fire extinguishing systems, or where the exterior is a high fire hazard such as a flight deck.

### 9.2. Insulation

Aluminum must be sufficiently insulated in order to prevent the softening or deformation of aluminum in a fire. Steel, unlike aluminum, is not generally required to be protected by insulation because it is assumed that the temperatures of ordinary shipboard fires will not be above 900 °C (1,650 °F), which is well below the melting point of steel. Structural fire protection of aluminum is designed to prevent

the aluminum from reaching a temperature of 230 °C (446 °F).

It is important to note that to protect the aluminum in case of fire, insulation is required in situations where it is not needed in steel vessel design. This will add to the weight of the aluminum vessel and in some cases be a significant increase in weight due to the insulation.

With the proper use of insulation, aluminum can be used as the structural material for passenger and cargo vessels. However, aluminum may not be used for the structure of tank vessels or tank barges because standard fire test requirements do not account for the high temperatures of oil fires. In certain vessels, such as vehicle-carrying ferries, the major supporting members for structure above the vehicle deck must be steel.

The USCG has an approved equipment listing at <http://cgmix.uscg.mil/Equipment/Default.aspx> that describes various approved insulation fire resistance properties (structural protection times and thickness of the insulation) given a deck/bulkhead thickness.

### 9.3. Current Research

At the time of this manual different organizations are in the process of conducting research to improve the fire protection insulation that is required by aluminum structures. The materials mentioned below show promise, but have not been approved by regulatory bodies, and some of the test methods used are not standard.

A sprayed fire protection material was studied by Greene (65). Following a concern that materials that can be directly sprayed to the structure, a low-cost test was developed to simulate the dynamic forces that act on ship structural panels. The following materials were evaluated on aluminum structure:

- Isolatek International Cafco Blaze Shield II
- Span-World Distribution Temp-Coat 101 and Fyre Sheild
- Superior Products SP2001F Fire Retardant
- Carboline Intumastic 285

A product that meets European Directives 97/69, 80/1107, 89/391, and 98/24 is Fibrofax, made from synthetic vitreous fibers (of silicates) of random orientation, whose percentage by weight of alkaline oxides and alkaline-earth oxides ( $\text{Na}_2\text{O} + \text{K}_2\text{O} + \text{MgO} + \text{BaO}$ ) exceeds 18% (ALCAN, 2004). Fibrofax is 38 mm thick and weighs 3.65 kg / m<sup>2</sup> (0.228 lb / ft<sup>2</sup>) for A-30 protection and 50 mm thick and 4.80 kg/m<sup>2</sup> (0.30 lb / ft<sup>2</sup>) for A-60 protection.

The National Shipbuilding Research Program (NSRP) has conducted a study of improved fire protection insulation for

aluminum structure aimed particularly at the vehicle deck of ferries (94). The product studied under the project was estimated to weigh about 0.2 to 0.4 pounds per square foot (1.0 to 2.0 kg/m<sup>2</sup>), and have an installed cost ranging from \$0.07 to \$1.00 per square foot.

## 10. General Discussion of Fatigue / Fracture

The topic of fatigue/fracture design is one of great complexity and debate. Hundreds of books have been written on the topic and it is addressed in great detail by all shipbuilding classification societies. The purpose of this section is to present the designer with a progressive design method and various analysis techniques to evaluate designs for fatigue.

### 10.1. Elements of Fatigue Design

The section addresses many of the factors that should be considered when designing high-speed vessels for fatigue. The progression listed is applicable to all types of aluminum structures and serves as a checklist when solving fatigue problems and is listed as follows:

1. Establish if fatigue may be controlling
2. Minimize or prevent cyclic loads
3. Determine and estimate cyclic loads
4. Determine fatigue-critical sites and estimate stresses
5. Select analysis and design method
6. Prepare preliminary design
7. Evaluate robustness and cost
8. Verify design by test

The above steps are consistent with previously published Society of Automotive Engineers (SAE) fatigue design processes applicable to ground vehicles (116). A brief discussion of each item is included in this section; subsequent sections elaborate on select topics in more detail.

#### 10.1.1. Step 1: Establish if Fatigue May Be Controlling

Fatigue is an obvious design consideration for conventional ships and is of even greater importance with high-speed vessels. As high-speed vessels have increasingly flexible structures and often operate close to their design limits, the cyclic stresses caused by motion- and wave- induced loads occurring at high encounter frequencies tend to increase the rate in which fatigue damage is accumulated (8). Experience with in-service vessels of similar design and operating environment, especially those that have experienced fatigue failure, are the best guidance when evaluating the importance of fatigue.

#### 10.1.2. Step 2: Minimize or Prevent Cyclic Loads

Structural vibration caused by wind-induced or unbalanced machinery operating near a natural frequency are representative problems in which the structure generally will be damaged or destroyed unless the cause of the cyclic loads is controlled. For example, a 5-Hz frequency, which could be the first mode in bending of a structure, produces nearly

half a million cycles a day, and the amplitude of vibration can be large in lightweight aluminum high-speed vessels. Typically, avoiding forcing frequency/natural frequency ratios greater than 0.5 and less than 2.0 has produced favorable results with regard to structural vibration (111).

#### 10.1.3. Step 3: Determine and Estimate Cyclic Loads

In order to utilize any of the analysis design methods, load magnitudes and number of cycles that will be imposed on the structure must either be known or estimated. See Section 1.

#### 10.1.4. Step 4: Determine Fatigue-Critical Sites and Estimate Stresses

The location of all possible sites for fatigue failure in a complex structure and the selection of specific cases for which a detailed analysis is required can be a difficult task. Experience with similar structures, regardless of construction material, is the best source of information. In the absence of experience, joints, notches, abrupt changes in geometry and areas of localized loads and stresses are candidates for fatigue cracks and need to be considered.

Nominal stresses can easily be determined in simple structures utilizing strength of materials approaches; however, for more complex structures the stress analysis should include the entire three-dimensional structure as two-dimensional analysis of a structure typically does not account for secondary stresses.

#### 10.1.5. Step 5: Select Analysis and Design Method

There are generally five methods of fatigue analysis and design and are as follows:

- S-N
- Hot-Spot
- Strain Life
- Fracture Mechanics
- Good Practice

The use of S-N curves is by far the most common method of fatigue design. Stress-cycle curves are available through various specifications and codes that define “standard details” encompassing many types of members and joints. Design stresses used for the details are the nominal axial or bending stresses in the part and apply to all alloys and tempers of a material. A standard detail is selected similar to the one that is being designed and fatigue strength for the standard detail is used for the new joint. Care must be taken, however, as large errors in life estimation can result because small differences in geometry can cause large



differences in the local stress and, thus, large differences in the fatigue strength of the part.

The hot-spot method typically is utilized in the design of offshore and welded tubular steel structures and has seen increasing use in aluminum structures. This method is similar to the S-N method with the major difference being that the hot-spot method utilizes local stress which captures geometry effects of the detail vice the nominal stress in the part. The method has merit in applications in which the new detail is quite different from existing details and for which data are not available. The hot-spot method has been utilized extensively in the design of welded joints.

Strain-life design is primarily used for automotive components, farm machinery, and over-the-road equipment. This method requires an analysis that finds the strain magnitudes for the imposed loadings at the point of interest and strain life data obtained from laboratory tests of the material. The strain-life method has generally been applied to components such as holes and radii where stress concentrations are part of the design.

Fracture mechanics analysis is used extensively in the aerospace industry and the assessment of bridge structures. Crack-propagation data and fracture information of the alloys and tempers of interest are required. A calculation utilizing FEA may be required for complex geometries where simple mechanics calculations are insufficient. In the analysis, a defect is assumed and a crack propagation analysis is performed. If the crack grows to a critical length, fracture of the part occurs.

The final method of fatigue design is the use of “good practice”. Good practice simply means designing structures that make use of details known to be resistant to fatigue, and avoidance of stress concentrations and details known to be susceptible to fatigue cracks. In cases where loading is clearly defined and fatigue does not seem to be critical, fatigue-resistant joints should be used where practical. General guidelines include the use of gradual changes in geometry and stress distributions, the avoidance of hard spots or structural discontinuities, and the minimization of other localized stress concentrations.

#### 10.1.6. Step 6: Prepare Preliminary Design

In a preliminary design the following variables that must be addressed in order of importance are as follows:

- Geometry of component and joint
- Joining method
- Product form
- Alloy and temper

Geometry of a component and joint is the most important variable. The thickness of parts, transition of changes in geometry, and localized stress are all critical for fatigue and are governed by geometry. Effort should be made to place fatigue-critical details in a region of low stress or low cyclic loading to increase potential detail design options. The design of the detail establishes the fatigue strength and the size of the detail determines both the general stress level and the local stress level.

The method of joining a detail is the second most important variable. There are large differences in fatigue strength, depending on joining method. Also, there are large differences depending on the detail of the joint, for each of the joining methods. In aluminum shipbuilding, the two most common methods of joining are welding and bolting.

Welding is the preferred method of joining aluminum in ship construction. The fatigue strength of a groove-welded joint with a small height of weld bead and smooth transitions at the edge of the weld is greater than or equal to most mechanical joints. However, welded joints that utilize fillet welds with offset load paths and sharp radii at the toe of the welds tend to result in lower fatigue strengths. Thus the fatigue strength of a welded joint is widely variable with joint details. Evaluating the quality of welded joint detail can be cumbersome, as visual inspection is often insufficient requiring the use of x-rays or dye penetrants.

Outside of shipbuilding, bolting is the most common method for joining aluminum members. The fatigue strength achieved in well-fabricated bolted joint is often as high as that for most groove-welded joints and is higher than those for other types of welded details, such as those with a reinforcing plate. Mechanical joints are easy to fabricate and visual inspections are generally satisfactory to ensure that the fasteners are properly installed. However, at low stress levels, fretting failures can occur in bolted connections; friction joints have been shown to reduce the likelihood of fretting, but they are not generally attained in aluminum structures unless the faying surfaces of the joint are roughened to achieve a uniform and reliable coefficient of friction.

Aluminum is available in various product forms including sheet and plate, extrusions, forgings, and castings. With exception to castings, all product forms behave similarly in fatigue. The fatigue strength of castings is heavily dependent on the quality of the part, which is determined by the manufacturing processes utilized. Because most fatigue failures occur at joints, where practical, effort should be made to eliminate them through the use of extrusions, castings, etc.

Specifications for fatigue design of components usually use S-N curves that apply to all alloys and tempers. A single curve for each class of detail is typically specified because

joint fatigue strength does not vary significantly with alloy at long lives. Thus, for components that are required to resist large numbers of cycles, alloy and temper have little effect on the design. For designs requiring lower numbers of cycles, fatigue curves are higher for stronger joints, and alloy and temper could have some effect on design.

#### 10.1.7. Step 7: Evaluate Robustness and Cost

Inevitably, more than one design will satisfy load requirements, so the final selection of a design should consider the robustness and cost of the design. Robust designs generally maintain performance while being insensitive to manufacturing inaccuracies and defects. Rarely will a structure be fabricated perfectly and perform in service without being subject to some damage. If more than one robust design satisfactorily meets the requirements, final selection should be made on the basis of cost. Cost information on product forms, alloys, and fabrication may be needed to differentiate between designs.

#### 10.1.8. Step 8: Verify Design by Test

Regardless of the design method employed, there will be uncertainties about the adequacy of the design. Full-scale verification tests are usually made on structures in other industries. Environmental conditions can be introduced into the test, though long term effect can be difficult to realistically attribute. Full-scale testing of entire ship structures in shipbuilding, primarily due to cost and size, is not practical. In these cases, subscale testing and finite element models (FEMs) are options.

### 10.2. Design Methods

#### 10.2.1. S-N

The S-N design method relies on stress range versus the number of cycles for joint configurations for which data is available. The process of designing a new joint is to select a known joint configuration that is similar to the joint being designed and using the S-N curve to determine the life prediction. The accuracy of this method is dependent on the judgment of the design in selecting a similar joint configuration.

S-N curves may be expressed as a log-log plot using the following equation:

$$S_{rd} = C_f N^{-1/m} \quad (79)$$

Where:

- $S_{rd}$  = allowable stress range
- $C_f$  = constant defining the intersection on the S-N curve at the ordinate for one cycle
- $N$  = Number of cycles to failure
- $m$  = slope of the S-N Curve

S-N curves are available for many different joint types in current literature. These curves can be found in (4), (113), and (69). Two types of S-N approaches are taken: the infinite-life and the safe-life methods. Typically, the safe-life method is utilized to take advantage of an actual finite life which results in lighter, more economical structural configurations.

#### 10.2.1.1. Safe-Life Design

The safe-life design method is based off of the fact that a vehicle has a limited life span such as 20 years. Given the required life is 20 years, the designer is able to utilize the data from an appropriate S-N curve as the basis for the design.

For constant amplitude loading, the simplest case of fatigue loading is the constant amplitude fatigue loading which is how most S-N curves have been developed. For the constant amplitude case, the designer may determine the allowable design stress range by determining the expected number of loadings over the design life or in reverse determine the fatigue life from the design stress range.

In all cases, the allowable stress range,  $S_{rd}$ , shall be less than the value of Equation (79) when  $N = 5 \times 10^6$  cycles and shall not be greater than Equation (79) when  $N = 10^5$  cycles.

For weld details, mechanically fastened joints, and wrought materials, if the applied stress range  $S_{ra}$  (the difference between the minimum and maximum calculated nominal stress perpendicular to the expected plane of cracking) is less than or equal to the allowable stress range (depicted in Equation (80)), the joint design is considered satisfactory.

$$S_{ra} \geq S_{rd} \quad (80)$$

Fatigue design of castings shall be made in accordance with the Aluminum Design Manual testing program (4). Note, that if the applied stress range is less than the constant amplitude fatigue limit for a particular joint design, no further fatigue consideration is needed.

For variable amplitude loading with a more realistic loading with two or more stress levels, it is recommended to use Miner's law or the Miner-Palmgren Law. The Miner-

Palmgren Law is used for a number of reasons: 1) it is a simple calculation, 2) it produces fairly good estimates, and 3) the effects of the order of loading are generally washed out under random loading.

$$\sum \frac{n_i}{N_i} = 1 \quad (81)$$

Where:

$n_i$  = the number of cycles of the  $i$ th stress range  
 $N_i$  = the number of cycles to failure at the  $i$ th stress range

This equation is considered a measure of damage due to the loading at that level.

It is important to note that when examining a joint for variable amplitude loading, the endurance limit is not used. It has been found that stress cycles below the endurance limit can reduce the life of a variable-amplitude loaded joint. Therefore, all loading should be incorporated into the damage calculation.

The Aluminum Association's Aluminum Design Manual (4) takes this one step further to derive an equivalent stress range  $S_{re}$ .

$$S_{re} \leq S_{rd}$$

$$S_{re} = \left( \sum_{i=1}^{N_s} \alpha_i S_{ri}^m \right)^{1/m}$$

$$S_{rd} = C_f N^{-1/m}$$

Where:

$S_{re}$  = equivalent stress range  
 $S_{rd}$  = allowable stress range  
 $\alpha_i$  = number of cycles in the spectrum of the  $i$ th stress range divided by the total number of cycles  
 $S_{ri}$  =  $i$ th stress range in the spectrum  
 $C_f$  = constant from joint detail stress categories<sup>17</sup>  
 $m$  = constant from joint detail stress categories<sup>17</sup>  
 $N_s$  = number of stress ranges in the spectrum  
 $N$  = number of cycles to failure

<sup>17</sup>The Aluminum Design Manual (4) provides a list of constants for various joints. See Figure 3.1 and Tables 3.1 and 3.2 in the Aluminum Design Manual.

The allowable stress range  $S_{rd}$  shall not exceed the calculated  $S_{rd}$  in Equation (84) when  $N = 10^5$  cycles.

#### 10.2.1.2. Infinite Life Design

Infinite life design is appropriate for the design of components that are subject to millions of fairly constant amplitude loadings in noncorrosive environments. In the majority of cases, the marine environment is not conducive to these criteria, and, therefore, these methods are not suitable for marine design. The remainder of this section is for informational purposes only.

The component is designed for infinite life by proportioning the structure of the component so that the maximum static design stress is below the minimum endurance limit. An overload above the endurance load could either increase or decrease the likelihood of a fatigue failure significantly. The overload can induce compression stresses that significantly increase the fatigue life of the component or tensile stresses that significantly reduce the fatigue life of the component.

The only data required for infinite-life design is the endurance limit. The endurance limit is typically determined through fatigue testing and should be as representative as possible of the actual joint in service. It is important to note that the larger the structure, the more likely there will be a defect or discontinuity within the component. It is, therefore, recommended that a factor of safety be applied to the endurance limit or the allowable stress. Particular attention should be paid to fatigue preventive measures in the joint design for infinite-life designs.

#### 10.2.1.3. Mean Stress

There is a significant amount of discussion on how to determine the stress range if the cyclic loading causes both tension and compression in the joint. For un-welded material and bolted joints, it is the tensile stresses that contribute to fatigue crack initiation and propagation. The fatigue life decreases as the stress ratio  $\sigma_{min}/\sigma_{max}$  increases. For bolted or mechanically fastened joints, the Aluminum Association's Specification for Aluminum Design accounts for this by increasing the detail category for the joint as the stress ratio increases.

For welded joints, there are typically high residual tensile stresses in the welded joints and the stress range is adequate without any stress correction, and, therefore, it is the stress range – not the stress ratio – which determine the fatigue life of the welded connection.

#### 10.2.1.4. Environmental Effects

It should be noted that the design curves in the current Aluminum Association specifications cover normal use of aluminum alloys in service and do not provide for

reductions due to corrosive environments. Normal weathering will not affect the performance of aluminum joints but corrosion severe enough to cause pitting will lower the fatigue strength of a joint significantly. In the marine environment, the designer should take precautions such as the selection of corrosion resistant aluminum alloys and the use of protective coating to prevent corrosion from occurring. There is very limited data on fatigue of corroded samples and most tests in the laboratory are completed with accelerated corrosion tests and may not be indicative of samples subject to long term fatigue loading and exposure. The few tests that have been completed show that there is some benefit (1.5 to 2 times the life of bare sample) in painting areas subject to high stresses where fatigue cracks may initiate. Even with coatings, it is recommended that the designer apply factors of safety on mean fatigue strength of at least 1.7 and a reduction of the number of life cycles by a factor of 10.

### 10.2.2. Hot Spot Method

The hot-spot method of fatigue design's origins is in the designing of offshore welded tubular steel structures. In this method a single S-N fatigue curve applying to a particular type of weld detail and a local stress (hot-spot), determined by analysis or test, accounts for the effects of a joint detail's geometry. Because of the offset loading present in fillet weld details, axial and bending stresses develop near the weld toe; additionally the sharp notches cause high stress gradients and a high stress in the weld toe. Sharp notches are difficult to define quantitatively and the hot-spot stress is obtained by extrapolation of the stress gradient for the axial and bending portion of the stress and does not include the stresses from the local concentration. Fatigue provisions for tubular members in the current steel welding code allow the use of hot-spot stresses as determined by rational analysis in combination with a single fatigue curve for all joints. Several studies have been performed that have extended the validity of this method to aluminum structures. One study in particular determined that the Category B fatigue curve from the Aluminum Association's Aluminum Design Manual can be used to perform the hot-spot method when evaluating for long lives.

Determination of hot-spot stress for high speed craft is accomplished through two steps. The first is to create a global FEM of the craft. The FEM is analyzed utilizing previously defined dominant load conditions (see Section 1). High stress regions within the global model are analyzed further with detailed local FEMs. General guidelines for local FEM creation and analysis are as follows:

- Model should be sized such that areas of interest are sufficiently far away from the applied loads
- Applied loads should be either forces and/or enforced displacements from the global FEM

- Solid element models should have a maximum element size of 0.25t (1/4 the part thickness) while shell elements should have a maximum element size of 1t
- Stress Results
  - For fairly linear stresses away from the notch, the hot-spot stress can be obtained by extrapolation.
  - For nonlinear stress away from the notch, it is recommended that the principle stress closest to being perpendicular to the potential fatigue crack be used.

The recommended method to obtain the hot spot stress from the point at the toe of the weld is through the use of Lagrange interpolation techniques. Take four points,  $P_1$  to  $P_4$ , at measured distances of  $X_1$  to  $X_4$  from the weld toe, illustrated in Figure 26.

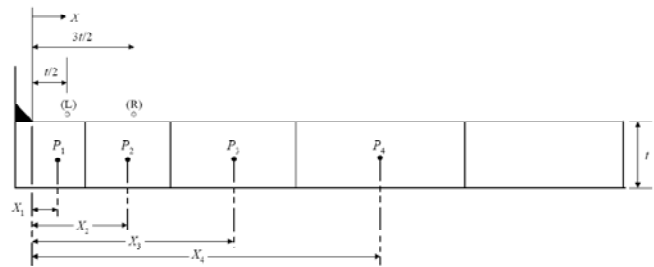

Figure 26. **Hot Spot Stress Interpolation Diagram (14)**

Each of these four points is located at the centroid of four neighboring finite elements beginning at the weld toe. Utilizing surface component stresses,  $S_i$  at  $P_i$  generated by the FEM analysis, the hot-spot stress can be calculated by the following procedure (14):

1. Select two points, L and R, such that point L and R are situated at distances  $t/2$  and  $3t/2$  from the weld toe:

$$X_L = \frac{t}{2} \quad (85)$$

$$X_R = \frac{3t}{2} \quad (86)$$

Where:

t = element thickness

2. Let  $X=X_L$  and compute the values for four coefficients, as follows:

$$C_1 = \frac{[(X-X_2)(X-X_3)(X-X_4)]}{[(X_1-X_2)(X_1-X_3)(X_1-X_4)]} \quad (87)$$

$$C_2 = \frac{[(X-X_2)(X-X_3)(X-X_4)]}{[(X_2-X_1)(X_2-X_3)(X_2-X_4)]} \quad (88)$$

$$C_3 = \frac{[(X-X_2)(X-X_3)(X-X_4)]}{[(X_3-X_1)(X_3-X_2)(X_3-X_4)]} \quad (89)$$

$$C_4 = \frac{[(X-X_2)(X-X_3)(X-X_4)]}{[(X_4-X_1)(X_4-X_2)(X_4-X_3)]} \quad (90)$$

The corresponding stress at Point L can be obtained by interpolation as:

$$S_L = C_1S_1 + C_2S_2 + C_3S_3 + C_4S_4 \quad (91)$$

- Let  $X=X_R$  and repeat step 2 to determine four new coefficient. The stress at Point R can be interpolated as:

$$S_R = C_1S_1 + C_2S_2 + C_3S_3 + C_4S_4 \quad (92)$$

- The corresponding hot-spot stress the calculated using the following:

$$S_0 = (3S_L - S_R)/2 \quad (93)$$

The  $S_0$  serves as a replacement for the applied stress in calculating fatigue life via the S-N method described in Section 10.2.1.

### 10.2.3. Strain-Life Method

Strain-life concepts and their use in life predictions are well documented; the method is often referred to as the notch-strain analysis technique. The methodology combines material behavior and local strains in the critical regions of a part for life prediction based on the initiation of a crack. A major assumption is that there is no initial crack in the part, only a highly strained region in which a crack starts. The definition of the initiation crack size is subjective, but the crack size is relatively small compared to the size of the part and on the order of 0.01 in long.

There are three steps in performing a strain-life analysis:

- Develop strain-life curves for the alloy and temper of interest
- Calculate strain at critical areas of the structure
- Perform life prediction

The data to develop strain-life curves are obtained from cyclic tension-compression test of smooth specimen in laboratory environments. When the curves are plotted, the ordinate is the strain range divided by 2 and the abscissa is

the number of reversals or twice the number of cycles. The curve takes into account elastic and inelastic (plastic) strain contributions. The equation of the strain-life curve is as follows:

$$\frac{\Delta\varepsilon}{2} = \frac{\Delta\varepsilon_e}{2} + \frac{\Delta\varepsilon_p}{2} \quad (94)$$

$$= \frac{\sigma'_f - \sigma_m}{E} (2N_f)^{f_s} + \varepsilon'_f (2N_f)^{f_d} \quad (95)$$

Where:

$\frac{\Delta\varepsilon}{2}$	=	one-half of the strain range, total strain amplitude
$\frac{\Delta\varepsilon_e}{2}$	=	one-half of the strain range, elastic strain amplitude
$\frac{\Delta\varepsilon_p}{2}$	=	one-half of the strain range, plastic strain amplitude
$\sigma'_f$	=	fatigue-strength coefficient
$\sigma_m$	=	mean stress
E	=	modulus of elasticity
$2N_f$	=	number of reversals to failure
$f_s$	=	fatigue-strength exponent
$\varepsilon'_f$	=	fatigue-ductility coefficient
$f_d$	=	fatigue-ductility exponent

The total strain amplitude,  $\Delta\varepsilon/2$ , shown in Figure 27, as a result of the steady-state hysteresis loops from material testing, is divided into both elastic and plastic components. At a given life,  $N_f$ , the total strain is the sum of the elastic and plastic strains. Both the elastic and plastic curves can be approximated as straight lines. At large strains or short lives the plastic strain component is predominant, and at small strains or longer lives the elastic strain component is predominant. This is indicated by the straight-line curves and the sizes of the hysteresis loops in the figure. The intercepts of the two straight lines at  $2N_f = 1$  are  $\sigma'_f/E$  for the elastic component and  $\varepsilon'_f$  for the plastic component. The slopes of the elastic and plastic lines are  $b$  and  $c$  respectively (120).

There are a number of methods that can be used to determine strains in a part. Occasionally, there are test data for the alloy and geometry of interest. Usually analysis will be employed, and if the structure or behavior is complex, FEA probably will be needed. This type of analysis is most general and the most accurate available. When using FEA, a material nonlinear analysis is performed because inelastic

strains are needed. The mesh size should be small enough to capture the peak strains at the notch root, and the stress-strain curve employed is based on the results of the cyclic material tests.

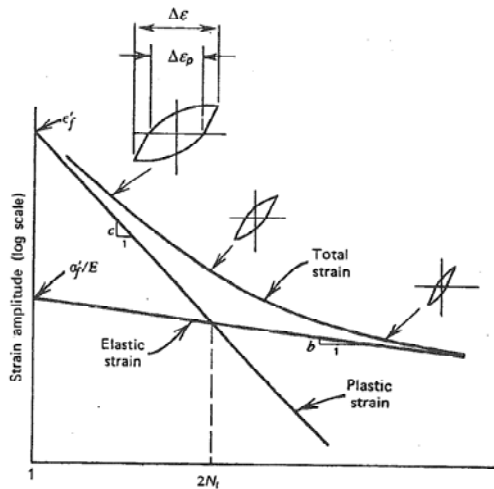

Figure 27. **Reversals to Failure,  $2N_f$  (log scale)**  
(120)

When predicting fatigue life there are two cases that need to be considered, constant- and variable- amplitude loading. Constant-amplitude loading may be present in components of machinery that are operating at a constant speed; however, in most cases, the parts will be subjected to a load spectrum, so that variable amplitudes of strains need to be incorporated in the design.

In constant-amplitude loading, only one level of cyclic load is applied; therefore, only one strain range must be calculated. The strain range is obtained from an FEA. The calculated strain values and strain-life curve for the alloy and temper of interest provides the number of reversals to failure.

Variable-amplitude loading is more complex in that a spectrum of load levels is used to calculate various levels of strain. A cumulative-damage procedure, similar to that used with the S-N method, is used to determine the fatigue life. In terms of strain reversals, the equation is as follows:

$$\sum \frac{2n_i}{2N_i} = 1 \quad (96)$$

Where:

- $2n_i$  = number of reversals applied for load range  $i$
- $2N_i$  = number of reversals to failure for load range  $i$

The number of reversals for the applied loads is obtained from the spectrum identified for the design case. The number of reversals for each load level is obtained from load-strain relationships and a strain-life curve. The total number of repetitions to failure is obtained using Equation (96) above.

For design using the strain-life method, some factor of safety should be applied to account for the approximate nature of the analysis and the variation in test data with test, lots of material, etc. One possibility is to reduce the level of the strain-life curve similar to that for S-N curves; this approach produces a factor of safety on strain of 1.7 and a factor of safety on reversal of 10, which ever gives the lower value (113).

#### 10.2.4. Fracture Mechanics

Both the physical and mathematical bases for linear elastic fracture mechanics have been around for nearly half a century. The method assumes the presence of an initial flaw which propagates under cyclic loads to a size that causes failure of the component. Final fracture occurs when either the toughness of the material is exceeded or the remaining material yields. Most fabricated engineering components contain initial defects such as weld porosity, inclusions, scratches, and dings. Further assumptions would include small-scale yielding confined to the immediate region around the crack tip, and conditions of similitude.

Several steps are required for the calculation of fatigue life and include:

1. Determine the location of potential crack sites, and perform a stress analysis which is consistent with mode I behavior.
2. Estimate the probable size of initial discontinuities.
3. Determine and calculate a stress intensity solution of the geometry of interest.
4. Determine the loading profile, whether constant- or variable- amplitude; environmental conditions of the fielded structure should also be considered.
5. Determine the fatigue-crack growth response of the material of interest.
6. Calculate fatigue life.

##### 10.2.4.1. Structural Analysis

Fatigue cracks form in components at connections, weld details, section where there are significant changes in stiffness, cutouts, copes, holes, scratches, etc.

Fatigue cracks can propagate in any of the modes illustrated in Figure 28(a). Mode I is the opening mode, which is the

most common, particularly in fatigue. Mode II is the in-plane shearing or sliding mode, and mode III is the tearing or anti-plane shearing mode. Mode I type cracks are the most common, primarily because cracks tend to grow on the plane of maximum tensile stress. This is the typical mode of crack for uniaxial loaded components. Mixed-mode crack propagation is associated more closely with the extension of microscopic fatigue cracks, as these cracks tend to grow on planes of maximum shear. An example of a mixed-mode I and II crack inclined with respect to the x-axis is shown in Figure 28(b). When  $\beta = 90^\circ$  or when  $\beta$  is large but less than  $90^\circ$ , the mode I contribution tends to dominate the crack tip-stress field. Often mode II and III cracks in combination with mode I cracks turn into mode I cracks (120).

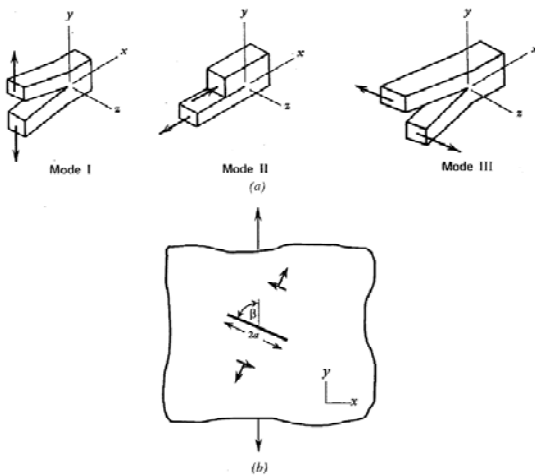

Figure 28. **Modes of Crack Extension (120)**  
**(a) Three basic modes of loading, (b) Mixed mode I and II loading due to a crack on an inclined plane.**

#### 10.2.4.2. Initial Flaw Size

Choosing the initial crack size is a difficult decision. It has been suggested that the crack size used should be a function of the resolution of the nondestructive evaluation capabilities i.e. the largest discontinuity or crack which could escape detection. Experience with welded aluminum components has demonstrated that typical initial discontinuities vary between 0.0005 in and 0.015 in. In lieu of destructive or nondestructive examination, an attempt to place bounds on the life estimate by using the smallest and largest initial discontinuity sizes expected is best. For design, the larger value, 0.015 inch, may be taken as a conservative estimate.

#### 10.2.4.3. Stress Intensity Solutions

Stress-intensity solutions have been developed for many geometries and are available in a number of texts<sup>18</sup>.

<sup>18</sup> Peterson's *Stress Concentration Factors* (105) lists the following references as sources of stress concentration

Another approach is the use of fatigue-life prediction or specialized FEA fatigue software (typically, FEA software vendors offer an optional fatigue analysis package). Other techniques make use of standard finite-element models to find stress-intensity factors along an expected crack path.

#### 10.2.4.4. Loading Profile

A thorough description of the loading profile would include information on waveform, stress amplitudes, frequencies, stress ratios, and operating environment. Waveform and frequency have more effect when the structure is operating in a severe environment and the amount of reaction time is critical. Welded joints have large tensile residual stresses around the weld, and accordingly the crack propagation data used in life-prediction studies should be obtained under high stress ratio conditions or under a constant maximum stress intensity. Both tend to minimize closure and mimic the conditions of crack growth in welded joints. Base-metal component should employ crack-growth data which best for the loading seen in service. If the component is subjected to variable loading, multiple crack-propagation curves would be required, as the crack-growth rate for a given stress intensity range increases in conjunction with the stress ratio, R. This concept is illustrated in Figure 29.

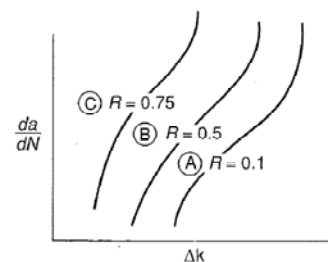
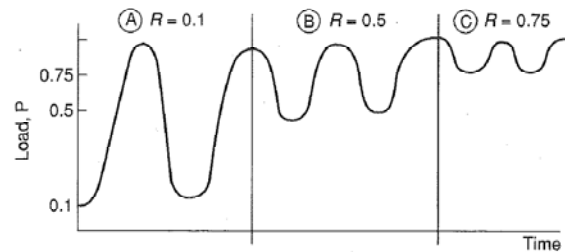

Figure 29. **Crack Propagation Data for Variable-Amplitude Loading (113).**

#### 10.2.4.5. Material Response

Environmental conditions affect the rate of crack propagation. Crack-growth rate data need to be obtained under conditions consistent with the intended service. If the

factors: (99), (101), (104), (108), (109), and the 1989 (7<sup>th</sup>) Edition of (134).

service environment is corrosive, test data should be developed in a corrosive environment similar to that expected in the field. Along with the fatigue crack-growth data, either a measured or estimated value of the crack-growth threshold is required. In design, a conservative assumption is that of no threshold. Additional information on material properties is required. Both yield strength and fracture toughness<sup>†</sup> are needed to determine the final crack size.

#### 10.2.4.6. Fatigue Life Prediction

Integration for fatigue life is a relatively simple matter once the structural analysis, loading profile, and material response have been established. Crack growth-rate data may be represented as follows:

$$N = \int_{a_i}^{a_f} \frac{da}{C_i \Delta K^{n_i}}$$

Where:

- c = crack size
- N = number of cycles
- $\Delta K$  = stress-intensity range
- $C_i$  and  $n_i$  = fitting parameters
- $c_i$  = initial crack size
- $c_f$  = final crack size

In cases where  $\Delta K$  is a simple function of crack length, the expression may be integrated directly. Where the stress-intensity solution is more complex, numerical integration is required. Further, the S-N curve may be developed for a specific combination of initial crack length and geometric conditions by simply varying the nominal stress.

Fatigue life prediction for variable-amplitude loading is more difficult. If the loading is truly random in nature and the net stress ratio is about 0.6, than many of the crack retardation-acceleration mechanisms are washed out. This is often the case for welded structures where large tensile residual stresses exist in the vicinity of the joint. In this case, a cycle-counting procedure should be used to reduce the loading history to a histogram. Each stress range in the spectrum may be considered a block of constant-amplitude loading. One major assumption is that the crack-growth rate does not change significantly over the block length. The histogram provides stress levels and frequency of occurrence. It is generally found that the rate does not change significantly if the block length is limited to 100 cycles.

As with the previously mentioned methods, a factor of safety should be applied. A factor of 1.7 on stress range or 10 on life is consistent with current industry standards (113).

#### 10.2.5. Good Practice

Good engineering practice in the design of fatigue critical structures or structures in which it is not known whether or not fatigue could be critical is to incorporate joints and details that minimize local stresses, recognizing that the designs need to meet some practical limits on cost. Hard spots should be avoided at all costs, and joints that provide a gradual, smooth transition from one part to the next and that minimize local stresses provide the best fatigue strength. This may be accomplished by shaping the parts being joined to avoid abrupt change and/or shaping the weld bead to minimize the stress concentration. Additional information concerning structural detail selection is in Section 6.5.

#### 10.2.6. Selection of Method

Of the methods considered, the S-N approach is the easiest to apply and should be considered for most preliminary designs. If there information on the design detail of interest is not available, the S-N method is more difficult to apply because the designer must try to match the new joint with an existing one with the same local stress field. The hot-spot method has merit because it allows for explicit calculation of the significant stresses due to geometry. If the rates of crack growth, inspection intervals, and/or residual strength of a component are important, fracture mechanics should be employed. If the number of cycles to failure is low, less than 1000, the strain-life method should be considered (113). Note, infinite life design is not suitable for marine design.

#### 10.2.7. Inspection Plans for Structural Fatigue Deterioration

Potential fatigue issues should be addressed at the design stage. Even so there are uncertainties in the calculations, construction process, and in the field. High speed vessels are typically optimized to be as light as possible while meeting some minimum fatigue life. Due to aluminum's susceptibility to fatigue cracking, it is recommended that the owner, designer, and builder establish an inspection program for implementation when the ship is built and in operation. This will allow fatigue life to be calculated retrospectively paying attention to detail before the fatigue life expires. Advanced planning during the design phase will allow for budgets and plans to be made and repairs to be carried out in a controlled manner.

Tradeoffs must be made during the design phase determining what the operating envelope of the craft is going to be, how rugged the vessel must be and how long the vessel needs to last. Every decision will result in some



compromise of cost versus performance and both of these factors need to be understood early on so that the final design meets the owner's expectations.

Inspections are time-consuming and can be costly. It is desirable to conduct "informed" inspections by:

- Focusing inspection sources towards structural areas that are most prone to failure or degradation
- Properly consider previous inspection results and relevant information
- Clearly state acceptance criteria (preferably in quantitative terms)
- Applying structural condition monitoring techniques when possible
- Using data management tools to store and trace historical data

Key components of an inspection program should include:

- Accessibility to inspect known areas of high stress concentration
- Document areas of expected local high stress
- During post-build inspection, document discontinuities produced during construction
- Create an inspection schedule based on expected corrosion rates, expected service and calculated fatigue life
- Create a ship database to record locations of problems and fixes
- Modify inspection program based on real world exposure / experience
- Utilize nondestructive examination/testing (NDT) and monitoring technologies, such as ultrasonic thickness measurement (UT), magnetic particle inspection (MPI), vibration measurement and strain measurement

Particularly important during the life of the vessel is reporting and documentation of inspection results. Application of information technology to properly store the data and facilitate fast and accurate exchange of data should be planned for and implemented.

Note that structural health (or condition) monitoring systems are developing rapidly and are likely to become commonplace in the future and their incorporation should be considered during the design phase.

## 11. General Discussion of Corrosion

There are seven major forms of corrosion that can have a large impact on aluminum. Uniform corrosion, which is also known as general corrosion, acts independently of the material's microstructure and component design. It is mainly dependent on the environmental conditions and the material's composition. This form generally corrodes at a much slower rate than the other forms of corrosion. The other forms of corrosion are dependent on the environment, component and system design, and/or the microstructure of the material. The following sections will discuss these forms of corrosion as well as control, monitoring, inspection, and testing methods for aluminum systems and/or components. Also to be discussed in this section is design considerations to prevent corrosion in areas that involve joining and riveting of the aluminum systems (52).

### 11.1. Types of Corrosion

There are several types of corrosion – uniform corrosion, pitting, stress corrosion cracking (SCC), intergranular corrosion, exfoliation corrosion (EXCO), crevice corrosion, and galvanic corrosion – which affect alloys in different ways.

#### 11.1.1. Uniform Corrosion

Uniform corrosion is a general corrosion that occurs on a large area of a material. This form of corrosion is only dependent on the environment and the material's composition. Uniform corrosion results in the thinning of the material. In most cases, an oxide layer develops on the surface of the material, decreasing the rate of corrosion; however, in some extreme environments this layer can be prevented from forming. Uniform corrosion can be accelerated by the existence of additional forms of corrosion (52).

#### 11.1.2. Pitting

Pitting corrosion is a highly localized form of corrosion that attacks a metal causing small holes or pits. This form of corrosion occurs once the oxide layer or protective coating of the metal is perforated due to chemical degradation or mechanical damage. Pitting can occur at a rapid rate, and it penetrates the metal without causing it to lose a large amount of weight. Pitting is very difficult to predict and measure due to the large amount of pits with varying depths and diameter. These pits also do not form uniformly or constantly under a specified condition. When pits form, they begin on the surface of the material and deepen parallel with the direction of gravity. This method of growth leads to a much larger depth of a pit than diameter. Once pitting begins, the growth of a pit will accelerate significantly. Aluminum items in an environment containing chlorides and aluminum brass in contaminated or polluted water are

usually the configurations most susceptible to pitting corrosion (52).

#### 11.1.3. Stress Corrosion Cracking (SCC)

Stress corrosion cracking (SCC) occurs in metals when the item is subjected to tensile forces in a corrosive environment. SCC occurs from a static stress that is applied to a material. SCC occurs within the material, where the cracks propagate through the internal structure leaving the surface unharmed. There are two main forms of SCC, *intergranular* and *transgranular*. The intergranular form occurs along the grain boundaries while the transgranular form penetrates the grains. Residual, thermal or welding stresses along with a corrosion agent can promote SCC. Pitting corrosion has also been found to initiate SCC. SCC is a dangerous form of corrosion because it is difficult to detect and can form under the designed stress levels of a material (52).

#### 11.1.4. Intergranular Corrosion

Intergranular corrosion occurs at the material grain boundaries due to variations of the composition of the metal between boundaries. This form of corrosion is associated with the impurities of a material which deposit at grain boundaries and/or a difference in phase that is precipitated at the grain boundaries. Heating of some metals through processes such as heat treatment and welding can increase the level of non-homogeneity increasing the chance of intergranular corrosion. Aluminum alloys also suffer intergranular attack as a result of precipitates at grain boundaries that are more active. Alloys that fall into this type of corrosion include 5083, 7030, 2024, and 7075. The best method to limit intergranular corrosion is to reduce impurity level and to properly select heat treatment to reduce precipitation at grain boundaries (52). 5xxx-series aluminum alloys with high levels of magnesium are more susceptible to intergranular corrosion due to sensitization of the alloy over time in service or through improper treatment during production (115).

In 2002, ASTM formed the ASTM B07.03 Task Group on Marine Alloys to address the problem of intergranular corrosion. The Aluminum Association formed a similar group as well. This new task group developed a new specification for marine aluminum alloys, ASTM B 928-04, High Magnesium Aluminum-Alloy Sheet & Plate for Marine Service. This specification replaces specification ASTM B 209 for all high magnesium ( $\geq 3\%$ ) alloys and tempers intended specifically for marine application service. The new specification B 928-04 required that all high magnesium alloys pass the ASTM G 67 (NAMLT) test to determine an alloy's susceptibility to intergranular Corrosion, and the ASTM G66 (ASSET) test to determine susceptibility to exfoliation corrosion. The new ASTM B928-04 standard and the Aluminum Association have

redefined the H116 and H321 tempers for wrought products in the 5xxx-series as marine plate tempers and assigned both exfoliation and intergranular corrosion resistance criteria as appropriate (52). The difference is H116 products are strain hardened and H321 products are thermally stabilized (116).

#### 11.1.5. Exfoliation Corrosion

Exfoliation corrosion is considered a form of intergranular corrosion that attacks metals which have been mechanically deformed in methods such as rolling and extruding. Mechanical deformation of metals produces elongated grains that are directionally aligned. In most cases, the initial attack begins at the exposed end-grains of the material. Like intergranular corrosion, the best method to limit intergranular corrosion is to reduce impurity level and to properly select heat treatment to reduce precipitation at grain boundaries (52).

#### 11.1.6. Crevice Corrosion

Crevice corrosion occurs when a liquid becomes entrapped in a localized area due to a component/system design. These design features include sharp angles, fasteners, joints, washers and gaskets. Crevice corrosion can also occur under debris build up on surfaces which can be severe due to increased acidity in the crevice. An anodic imbalance is created in a crevice due to the lack of oxygen in comparison with the surrounding material. This imbalance creates a highly corrosive micro-environment. The degree of corrosion is affected by the crevice gap, depth and surface ratios of the materials. As the depth and size of the surface area increase, so does the rate of corrosion. Also, tighter gaps have shown to increase the rate of corrosion as well. Because aluminum is a passive metal, it will generally have a greater susceptibility to crevice corrosion. Prevention of crevice corrosion begins with a design that minimizes crevice areas. Welded joints are preferred over fastener-type joints and the crevice area should be sealed to prevent any standing water. If water build up is expected in a design, drain holes can be added to allow water to escape. Also, a regular cleaning schedule should be implemented to prevent the buildup of debris which could cause corrosion (52).

#### 11.1.7. Galvanic Corrosion

Galvanic corrosion occurs when two dissimilar metals with different electrical potentials are in contact such that an electrical current can flow between them. This reaction is typically greatest at the contacting surfaces. Electrical current can be passed through direct contact or through an electrical conducting medium such as an electrolyte. The extent of the corrosion depends on the materials in contact, the environment, and the ratio of material area. This reaction will develop an electrical current which will attract electrons from one metal to another. The metal taking the

electrons acts as the anode while the opposing metal acts as the cathode. This reaction will cause an increase in corrosion resistance for the cathode. The anode and cathode in this reaction are identified by the metals' electrical potentials in relation to each other. The metal with the lower electrical potential acts as the anode, while the one with the higher potential acts as the cathode. Figure 30 shows some of the common metallic elements and their typical electrical potentials (52).

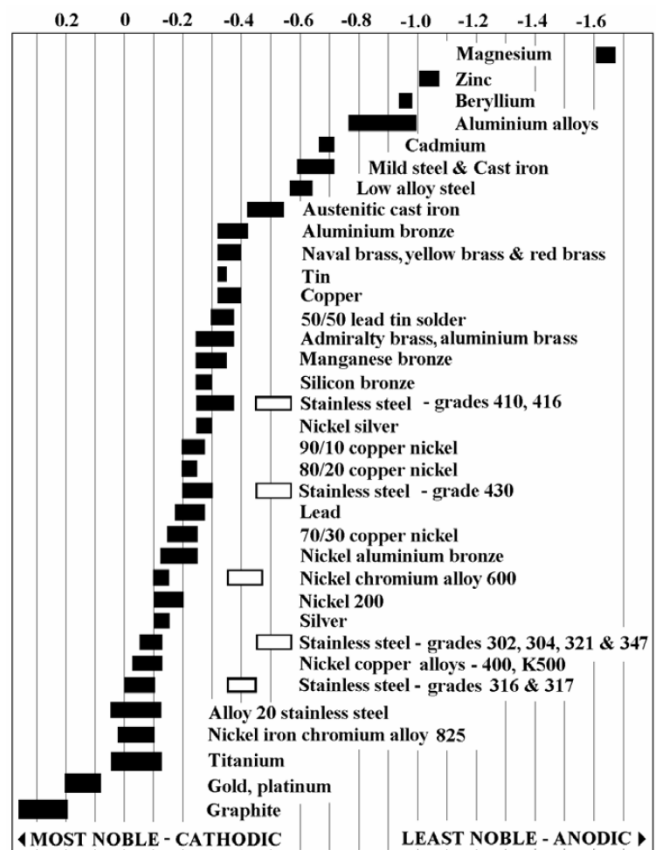

Figure 30. Electrical Potential of Common Metals (39)

#### 11.2. Sensitization

Alloys containing significant amounts of magnesium (greater than 3% by weight) may be susceptible to sensitization. Sensitization occurs during the service life of the alloy when it is exposed to elevated temperatures.  $\beta$  phase precipitates ( $Al_2Mg_3$ ) migrate to the grain boundaries. These precipitates are brittle and anodic compared to the surrounding grains. The results of sensitization are increased susceptibility to stress corrosion cracking and exfoliation, decreased ductility, reduced service life, and reduced tensile strength and hardness. Studies of sensitization have been and are currently being conducted using the ASTM G67 (28) test (see 11.4.3.9). ASTM B 928 now requires applicable alloys pass the G66 (27) (see

11.4.3.8) and G67 (28) (see 11.4.3.9) tests. As this is a recently discovered phenomenon, studies are still being conducted, and requirements and standards may change (49) (121) (133).

### 11.3. Corrosion Control Methods

Aluminum oxidizes quickly in a marine environment which causes the aluminum to form a protective layer. If the protective layer cannot be maintained, the aluminum will corrode at a rapid rate. The corrosion resistance of the aluminum alloys vary in stagnant or low-velocity seawater. The 2xxx-series of aluminum alloys, in general, are highly susceptible to corrosion and are not suitable for use in marine environments. The 6xxx- and 7xxx- series aluminum alloys exhibit a good resistance to localized and crevice corrosion in seawater environments depending upon temper. The 3xxx- and 5xxx-series of aluminum alloys have typically shown to have the best resistance to corrosion in seawater environments. The selection of materials for corrosion resistance should simply take into consideration the susceptibility of the metal to the type of environment that will be encountered. The various types of corrosion control methods for aluminum include the use of inhibitors, surface treatments, coatings, sealants and cathodic protection (52).

#### 11.3.1. Inhibitors

Inhibitors are chemicals which react with the surface of a material or interact with the operating environment to decrease the materials rate of corrosion. Inhibitors can be added into an operating environment as a solution or dispersion where they form a protective layer on the material. They can also be added into the coating products or water that is used to wash down a vehicle, system or component. When interacting with the metal, inhibitors slow the corrosion process in three ways: 1) they shift the corrosion potential of the metal surface toward the anodic or cathodic end, 2) prevent permeation of ions into the metal and 3) increase the electrical resistance of the surface (52).

#### 11.3.2. Surface Treatments

Surface treatments improve the surface characteristics of a material using modifications such as conversion coating, anodizing, shot-peening, and laser treatment. Conversion coatings and anodizing utilize chemical reactions which create a corrosion resistant oxide film layer on the surface of the material. Shot-peening improves SCC and corrosion fatigue resistance by utilizing a mechanical process which induces a compressive residual stress on the surface which relieves tensile stress within the material (see also, Section 6.3.7). Laser treatments use heat to make modification to the surface of a material by melting or inducing compressive stress to change the surface characteristics (52).

#### 11.3.3. Coatings and Sealants

Coatings are used to provide long-term corrosion protection of metals in various types of corrosive environments. These various types of coatings can be metallic, inorganic or organic. Two types of coatings are barrier coatings and sacrificial coatings. Barrier coatings act as a shield to the surrounding environment, are un-reactive, resistant to corrosion, and protective against wear. Sacrificial coatings act as a sacrificial anode and provide cathodic protection by supplying electrons to the base metal. Sealants are used to provide protection by preventing moisture penetration (52).

#### 11.3.4. Cathodic Protection

Cathodic Protection (CP) protects a structure or components utilizing an electrochemical method to protect against galvanic corrosion. A CP system contains an anode, cathode and an electrical connection between the two in an electrolyte. This form of protection suppresses the dissolution of the cathodic material by supplying it with electrons, which causes the anodic material to be corroded instead. There are active and passive type cathodic protection systems. The active system develops a small DC current in the hull to reduce the electric potential between differing metal alloys. The active system is generally utilized with a coating system to provide redundancy. The passive system is comprised of sacrificial zinc anodes mounted to the hull near different metal alloys. In the passive system the sacrificial zinc anodes corrode instead of the aluminum hull (52).

### 11.4. Corrosion Monitoring and Inspection

There are many different methods used to monitor and inspect components and systems for corrosion and corrosion related damage. Corrosion monitoring utilizes methods which assess the corrosivity of a system possibly in real-time in order to monitor the system for defect formation. Corrosion inspections are performed periodically to evaluate the system for corrosion and corrosion related defects.

#### 11.4.1. Corrosion Monitoring

Corrosion monitoring manages the corrosivity of the surrounding environment as well as the wear on components. There are a few methods that can be used to monitor corrosion in the field. One method uses probes that monitor the chemical or electrochemical nature of the environment. These results are then compared to known corrosion rates. These can sometime lead to erroneous corrosion rate determinations because the probes could be affected under certain conditions. Coupon testing can also be used as a simpler method to measure the corrosion rate of a material. Another method of monitoring is the use of acoustic emissions, which are used to detect formations of surface and subsurface damage in a material (52).

#### 11.4.2. Corrosion Inspection

Corrosion inspections take place periodically to evaluate the effects of corrosion on a given material or system. Inspections can utilize low-technology methods such as visual inspection, liquid penetrate inspection, and magnetic particle inspection which are limited to surface damage only. The inspections can also utilize higher-technology methods such as x-rays, sound waves, or heat, and measure the absorption/reflection of the energy. These high-technology methods can detect damage below the surface, damage in hidden areas, and damage that cannot be seen in a visual inspection. The success of these tests is dependent on the experience of the operator in locating the affected and damaged areas (52).

#### 11.4.3. Corrosion Testing

Corrosion testing is essential when determining the control, monitoring, and inspection criteria for any material that is placed in a marine environment. The following section calls out multiple tests that should be utilized when designing aluminum components, systems and/or structures. The majority of these tests are accelerated corrosion tests but an atmospheric test must be done first to establish a good baseline for the material. This information is provided for information purposes. On well known alloys many of these test results are available.

##### 11.4.3.1. ASTM B117

ASTM B117 (19) provides a controlled corrosive environment which can be used to produce relative corrosion resistance information for sample specimens of metals and coated metals. These specimens are exposed to a salt fog solution which is prepared by dissolving  $5 \pm 1$  parts by mass of sodium chloride in 95 parts of water.

##### 11.4.3.2. ASTM G31

The ASTM G31 (21) test provides specifications for a general lab immersion test, particularly a mass loss test. The test consists of immersing samples in a 3.5% sodium chloride solution for thirty days. After thirty days, the samples are weighed to determine material mass loss.

##### 11.4.3.3. ASTM G34

The ASTM G34 (22) test is an accelerated exfoliation corrosion (EXCO) test for 2xxx and 7xxx series aluminum alloys. The test requires constant immersion of specimens in a solution containing 4 M sodium chloride, 0.5 M potassium nitrate, and 0.1 M nitric acid at  $25 \pm 3^\circ\text{C}$  ( $77 \pm 5^\circ\text{F}$ ). The susceptibility to exfoliation corrosion is visually examined and given a rating based on standard photographs.

##### 11.4.3.4. ASTM G44

The ASTM G44 (23) is an alternate immersion test and is primarily used for aluminum alloys and ferrous alloys. This

test is typically used to evaluate stress corrosion cracking. This test has also been used to evaluate other forms of corrosion such as uniform, pitting, intergranular, and galvanic corrosion. The test is performed for a period of 20-90 days using an alternate immersion cycle in neutral 3.5% sodium chloride solution.

##### 11.4.3.5. ASTM G46

The ASTM G46 (24) provides guidance in the selection of procedures that can be used in the evaluation of pitting corrosion. These evaluation techniques can be used to determine the extent and effects of pitting.

##### 11.4.3.6. ASTM G47

ASTM G47 (25) characterizes the resistance to SCC of high strength aluminum alloys. This test determines the susceptibility to SCC of 2xxx (with 1.8 to 7.0% copper) and 7xxx (with 0.4 to 2.8% copper) aluminum alloys. The test uses constant-strain-loaded 0.125 in. tension specimens or C-rings exposed to 3.5% sodium chloride solution by alternate immersion.

##### 11.4.3.7. ASTM G50

The ASTM G50 (26) test provides information about long term exposure of a material to a particular environment. The environment is selected such that it is the same or similar to the operating environment. ASTM G50 requires exposure to the environment by placing specimens on a specifically-designed rack and examining them periodically. The weather conditions are recorded for the duration of the test. Specimens are removed after a specified duration and inspected with electro-resistance measurements.

##### 11.4.3.8. ASTM G66

ASTM G66 (27) is a constant immersion test to determine the susceptibility of 5XXX series aluminum-magnesium alloys containing 2.0% or more magnesium to exfoliation corrosion. Specimens are immersed for 24 h at  $65 \pm 1^\circ\text{C}$  ( $150 \pm 2^\circ\text{F}$ ) in a solution containing ammonium chloride, ammonium nitrate, ammonium tartrate, and hydrogen peroxide. The susceptibility to exfoliation is determined by visual examination using performance ratings established by reference to standard photographs. This test method provides a reliable prediction of the exfoliation corrosion behavior of Al-Mg alloys in marine environments. The test is useful for alloy development studies and quality control of mill products such as sheet and plate.

##### 11.4.3.9. ASTM G67

ASTM G67 (28) is a constant immersion test to determine the susceptibility of 5xxx series aluminum-magnesium alloys to intergranular corrosion. This test method will also evaluate the mass loss of the alloy, which will provide a quantitative measure of its susceptibility. This test method

provides a quantitative measure of the susceptibility to intergranular corrosion of Al-Mg and Al- aluminum-magnesium intermetallic compound (bAl-Mg), in preference to the solid solution of magnesium in the aluminum matrix. When this compound is precipitated in a relatively continuous network along grain boundaries, the effect of the preferential attack is to corrode around the grains, causing them to fall away from the specimens. Such dropping out of the grains causes relatively large mass losses of the order of 25 to 75 mg/cm<sup>2</sup> (160 to 480 mg/in<sup>2</sup>), whereas, samples of intergranular-resistant materials lose only about 1 to 15 mg/cm<sup>2</sup> (10 to 100 mg/in<sup>2</sup>). When the bAl-Mg compound is randomly distributed, the preferential attack can result in intermediate mass losses. Metallographic examination is required in such cases to establish whether or not the loss in mass is the result of intergranular attack. The precipitation of the second phase in the grain boundaries also gives rise to intergranular corrosion when the material is exposed to chloride-containing natural environments, such as seacoast atmospheres or sea water. The extent to which the alloy will be susceptible to intergranular corrosion depends upon the degree of precipitate continuity in the grain boundaries. Visible manifestations of the attack may be in various forms such as pitting, exfoliation, or stress-corrosion cracking, depending upon the morphology of the grain structure and the presence of sustained tensile stress.

#### 11.4.3.10. ASTM G69

ASTM G69 (29) is a test method that was developed to determine the corrosion potential of an aluminum alloy. The alloy is placed into an aqueous solution of sodium chloride with the addition of enough hydrogen peroxide to provide a good supply of cathodic reactant.

#### 11.4.3.11. ASTM G71

ASTM G71 (30) evaluates the galvanic corrosion of two dissimilar metals in electrical contact under low flow conditions. The low-flow conditions should not have flow velocity sufficient enough to cause erosion corrosion or cavitation.

#### 11.4.3.12. ASTM G85

ASTM G85 (31) is a salt spray (fog) test that has five modifications that can be utilized for specification purposes. These modifications are detailed in several annexes to ASTM G85:

- Annex A1, acetic acid-salt spray test, continuous.
- Annex A2, cyclic acidified salt spray test.
- Annex A3, seawater acidified test, cyclic (SWAAT).
- Annex A4, SO<sub>2</sub> salt spray test, cyclic.
- Annex A5, dilute electrolyte cyclic fog dry test.

This test method is useful in situations where the corrosive environment is more severe than that of salt fog test B 117 (19).

#### 11.4.3.13. ASTM G103

The ASTM G103 (32) test provides data concerning the forming of SCC in a metal. (The G49 specification provides specifications for the specimens used in the G103 test.) The G103 test requires continuous immersion in boiling 3.5% sodium chloride solution. It is common to use 6% sodium chloride rather than the 3.5% sodium chloride solution (Practice G44) in order to correlate better with marine atmospheric exposure, as noted in G103. The test is conducted for 168 hours.

#### 11.4.3.14. ASTM G104

The ASTM G104 (33) test evaluates typical assemblies of different metals after exposure to the atmosphere. The assemblies are placed on racks exposed to the atmosphere, typically near the ocean. This test has been cancelled but is still recommended because of its ability to test actual assemblies in the atmospheric conditions. This test helps to determine a good baseline for assembled items to be compared against from accelerated methods.

#### 11.4.3.15. ASTM G110

The ASTM G110 (34) requires immersion of etched specimens in an aqueous solution of 57 grams of sodium chloride and 10 mL of hydrogen peroxide per 1.0 L of solution. The etchant consists of 95 mL of reagent water combined with 2.5 mL of nitric acid (70%), 1.5 mL of hydrochloric acid (37%), and 1.0 mL of hydrofluoric acid (48%). The specimens are immersed for at least 6 hrs., after which the specimens are examined to determine the extent of intergranular corrosion (including a metallographic cross section).

#### 11.4.3.16. ASTM G116

ASTM G116 (35) is a galvanic corrosion test that wraps an anodic material in the form of a wire on a cathodic material that has been made into a threaded rod. This is then exposed to the atmosphere and a mass loss measurement of the anode material is taken after exposure.

#### 11.4.3.17. GM9540P

The GM9540P (64) test is a cyclic salt spray test used to simulate long term exposure to a marine environment. In a study conducted by NSWCCD (43), the 9540P simulates the performance of coatings when compared to the worst-case marine environment. Specimens are placed in a salt spray chamber and exposed to cycles of saltwater spray, humidity, drying, ambient and heated drying. The salt spray uses a solution of 0.9% sodium chloride, 0.1% calcium chloride, 0.25% sodium bicarbonate.

Fuch (120) and *Fatigue Design of Aluminum Components and Structures* by M.L. Sharp, G.E. Nordmark, and C.C. Menzemer (113).

## 12. Conclusions

The use of aluminum for the structure of high speed vessels seems a natural fit due to the weight savings that using aluminum can provide. However, the success of an aluminum ship design depends on many factors related to the various properties of aluminum and aluminum alloys. The design considerations include fatigue, fracture, corrosion, and fire. These concerns are related to engineering decisions made throughout the design process.

This guide was developed in order to better facilitate understanding of the high-speed aluminum ship design and construction process.

### 12.1. Further Reading

This guide has provided a summary of an extensive body of research material that is available. Readers interested in further study are referred to the following sources, which have been especially useful:

- *Aluminum and Aluminum Alloys* (edited by J.R. Davis and published by ASM) (53) is an excellent volume which provides additional details on aluminum and aluminum alloys as well as joining and manufacturing processes.
- The *Aluminum Extrusion Manual* (published by the Aluminum Extruders' Council) (7) provides a practical summary of the capabilities and considerations associated with producing a new extrusion.
- For information regarding welding, see *Metals and How to Weld Them* by T.B. Jefferson and G. Woods (76) and *Modern Welding Technology* by H.B. Cary and S.C. Helzer (49).
- Two overviews of vessel construction are *Ship Production* by R.L. Storch, C.P. Hammon, H.M. Bunch, and R.C. Moore and *Ship Design and Construction*. The latter resource was recently expanded to two volumes (83) and is now edited by Thomas Lamb; however, the older single-volume edition edited by Robert Taggart (124) is also useful.
- Concerning loading, J.S. Spencer's "Structural Design of Aluminum Crewboats" (119) and *Ship Design and Construction* (83) are useful. Rameswar Bhattacharyya's *Dynamics of Marine Vehicles* (44) is an excellent reference, but it is out-of-print and difficult to find.
- *Corrosion Prevention and Control: A Program Management Guide for Selecting Materials, Spiral 2* (by B.D. Craig, R.A. Lane, and D.H. Rose) (52) provides information on corrosion control, testing, and inspection.
- Two excellent resources for designing structures while considering fatigue are *Metal Fatigue in Engineering* by R.I. Stephens, A. Fatemi, R.R. Stephens and H.O

## Glossary

### B

*backer n.* – one of the components of a die assembly which supports the die

*bauxite n.* – a naturally occurring ore which is processed to produce aluminum

*billet n.* – a portion of a log which has been cut to an extruder's specifications prior to being extruded

*bolster n.* – one of the components of a die assembly which supports the backer

*bore v.* – to enlarge a hole using a single-point cutting tool

*brazability n.* – the ability of a metal to be joined using brazing or soldering

*broach n.* – a toothed tool head used to remove material from a part; *v.* – to remove material from a part using a broach or broaching machine

### C

*cap n.* – in a semi-hollow or hole extrusion die assembly, the die assembly component which forms the exterior features of an extrusion

### D

*die n.* – in a solid extrusion die assembly, the die assembly component which forms the extrusion features

*die ring n.* – in a extrusion die assembly, the component which supports and aligns the die, backer, die cap, and/or die mandrel

*drill v.* – to create or enlarge a hole using a drill bit

*ductility n.* – the ability of a material to deform plastically under tensile stress without fracture

*dye penetrant n.* – a solution which is used to highlight cracks during an inspection of a material

### E

*extrude v.* – to form (metal, plastic, etc.) with a desired cross section by forcing it through a die.

### F

*feeder plate n.* – in a solid extrusion die assembly, a component used as an alternative to a pocket type die

*fracture toughness n.* – the ability of a material containing a crack to resist fracture

### H

*hardness n.* – the ability of a material to resist plastic deformation due to indentation, penetration and scratching

*hollow adj.* – of an extrusion profile, having one or more completely enclosed voids

### I

*ingot n.* – metal formed into a standard shape using a cast mold, used for storage or transport

### L

*log n.* – a casting of an aluminum alloy prior to being cut into billets and extruded

### M

*mandrel n.* – in a semi-hollow or hollow extrusion die assembly, the die assembly component used to form the interior features

*melt-through n.* – during the welding process, when the arc burns through the thickness of the material

### P

*peen v.* – a process used to, among other things, relieve tensile stresses in a weldment and improve susceptibility to stress corrosion cracking

### R

*ream v.* – to create a hole using a tool consisting of a cylindrical head with teeth cut around the edge

*reference area n.* – the region of the hull where a majority of the peak slamming pressures occur. This region is forward of amidships and aft of the bow for monohulls and is roughly one-third of the water plane area.

### S

*semi-hollow adj.* – of an extrusion profile, having one or more partially enclosed void. A concave feature is considered a partially enclosed void when the area of the opening for the feature is less than some pre-defined ratio of the enclosed area.



*shear strength n.* – the ability of a material to resist yield or failure due to in-plane, parallel loading

*smelt v.* – to melt ore in order to extract the metal contained within

*solid adj.* – of an extrusion profile, having no enclosed internal voids.

*springing n.* – the resonant response of a hullform to wave-induced loads whose frequency of encounter overlaps the lower natural frequencies of hull vibration

*suckback n.* – shrinkage of the molten weld pool at the root due to incorrect root penetration, improper weld technique, or environmental conditions; also known as root concavity

## T

*tap v.* – to produce threads on a part using a form

*turn v.* – to remove material from a rotating part using a single-point cutting tool, usually performed on a lathe

## W

*weld plate n.* – syn “feeder plate”

## References

- (1) Ahmad, Z., "The Properties and Application of Scandium-Reinforced Aluminum", Journal of the Minerals, Metals, & Materials Society, Pennsylvania: 2003.
- (2) Alcoa Aluminum, *Welding Alcoa Aluminum*, Aluminum Company of America: 1958.
- (3) Allen, R.G. and Jones, R.R. "A Simplified Method for Determining Structural Design-Limit Pressures on High Performance Marine Vehicles" *AIAA/SNAME Advanced Marine Vehicle Conference*: 1978.
- (4) Aluminum Association, *Aluminum Design Manual* (ISBN: 978-0-9826308-0-8), The Aluminum Association: 2010.
- (5) Aluminum Association, *Aluminum Standards and Data, 2009*, The Aluminum Association: 2009.
- (6) Aluminum Association, *Fire Performance of Aluminum*, The Aluminum Association: 1996.
- (7) Aluminum Extruders' Council, *Aluminum Extrusion Manual (3<sup>rd</sup> Edition)*, [www.aec.org](http://www.aec.org), retrieved November 2009.
- (8) American Bureau of Shipping *Dynamic Load Approach and Direct Analysis for High Speed Craft*, American Bureau of Shipping: 2003.
- (9) American Bureau of Shipping, *Guide for Building and Classing High Speed Craft, September 2001*, [www.eagle.org](http://www.eagle.org), retrieved November 2009.
- (10) American Bureau of Shipping, *Guide for Building and Classing High-Speed Naval Craft, 2007*, [www.eagle.org](http://www.eagle.org), retrieved 2011.
- (11) American Bureau of Shipping, *Guide for Building and Classing Naval Vessels, 2007*.
- (12) American Bureau of Shipping, *Guide for Nondestructive Inspection of Hull Welds*, [www.eagle.org](http://www.eagle.org), retrieved 2010.
- (13) American Bureau of Shipping, *Rules for Building and Classing Aluminum Vessels, August 1975*, [www.eagle.org](http://www.eagle.org), retrieved November 2009.
- (14) American Bureau of Shipping, *Rules for Building and Classing Steel Vessels, 2011*, [www.eagle.org](http://www.eagle.org), retrieved 2011.
- (15) American Bureau of Shipping, *Rules for Materials and Welding Part 2: Aluminum and Fiber Reinforced Plastics (FRP) 2006*, [www.eagle.org](http://www.eagle.org), retrieved 2010.
- (16) American National Standards Institute (ANSI), *H35.1 Alloy and Temper Designation Systems for Aluminum*, ANSI: 2009.
- (17) American Society for Metals International, *ASM Handbook Vol 2: Properties and Selection: Nonferrous Alloys and Special-Purpose Materials* (ISBN: 978-0-87170-378-1), ASM International: 1990.
- (18) American Society for Testing and Materials, *ASTM A264-09 Specification for Stainless Chromium-Nickel Steel-Clad Plate*, ASTM [www.astm.org](http://www.astm.org), retrieved 2010.
- (19) American Society for Testing and Materials, *ASTM B117-09 Standard Practice for Operating Salt Spray Fog Apparatus*, ASTM [www.astm.org](http://www.astm.org), retrieved 2009.
- (20) American Society for Testing and Materials, *ASTM B928-04 Standard Specification for High Magnesium Aluminum-Alloy Sheet and Plate for Marine Service*, ASTM [www.astm.org](http://www.astm.org), retrieved 2010.
- (21) American Society for Testing and Materials, *ASTM G31-72(2004) Standard Practice for Laboratory Immersion Corrosion Testing of Metals*, ASTM [www.astm.org](http://www.astm.org), retrieved 2009.
- (22) American Society for Testing and Materials, *ASTM G34-01(2007) Standard Test Method for Exfoliation Corrosion Susceptibility in 2xxx and 7xxx Series Aluminum Alloys (EXCO Test)*, ASTM [www.astm.org](http://www.astm.org), retrieve 2009.
- (23) American Society for Testing and Materials, *ASTM G44-99(2005) Standard Practice for Exposure of Metals and Alloys by Alternate Immersion in Neutral 3.5% Sodium Chloride Solution*, ASTM [www.astm.org](http://www.astm.org), retrieved 2009.
- (24) American Society for Testing and Materials, *ASTM G46-94(2005) Standard Guide for Examination and Evaluation of Pitting Corrosion*, ASTM [www.astm.org](http://www.astm.org), retrieved 2009.

- (25) American Society for Testing and Materials, *ASTM G47-98(2004) Standard Test Method for Determining Susceptibility to Stress-Corrosion Cracking of 2xxx and 7xxx Aluminum Alloy Products*, ASTM [www.astm.org](http://www.astm.org), retrieved 2009.
- (26) American Society for Testing and Materials, *ASTM G50-10 Standard Practice for Conducting Atmospheric Corrosion Tests on Metals*, ASTM [www.astm.org](http://www.astm.org), retrieved 2009.
- (27) American Society for Testing and Materials, *ASTM G66-99(2005)e1 Standard Test Method for Visual Assessment of Exfoliation Corrosion Susceptibility of 5xxx Series Aluminum Alloys (ASSET Test)*, ASTM [www.astm.org](http://www.astm.org), retrieved 2009.
- (28) American Society for Testing and Materials, *ASTM G67-04 Standard Test Method for Determining the Susceptibility to Intergranular Corrosion of 5xxx Series Aluminum Alloys by Mass Loss After Exposure to Nitric Acid (NAMLT Test)*, ASTM [www.astm.org](http://www.astm.org), retrieved 2009.
- (29) American Society for Testing and Materials, *ASTM G69-97(2009) Standard Test Method for Measurement of Corrosion Potentials of Aluminum Alloys*, ASTM [www.astm.org](http://www.astm.org), retrieved 2009.
- (30) American Society for Testing and Materials, *ASTM G71-81(2009) Standard Guide for Conducting and Evaluating Galvanic Corrosion Tests in Electrolytes*, ASTM [www.astm.org](http://www.astm.org), retrieved 2009.
- (31) American Society for Testing and Materials, *ASTM G85-09 Standard Practice for Modified Salt Spray (Fog) Testing*, ASTM [www.astm.org](http://www.astm.org), retrieved 2009.
- (32) American Society for Testing and Materials, *ASTM G103-97(2005) Standard Practice for Evaluating Stress-Corrosion Cracking Resistance of Low Copper 7xxx Series Al-Zn-Mg-Cu Alloys in Boiling 6% Sodium Chloride Solution*, ASTM [www.astm.org](http://www.astm.org), retrieved 2009.
- (33) American Society for Testing and Materials, *ASTM G104 Standard Practice for Assessing Galvanic Corrosion Caused by the Atmosphere*, ASMT [www.astm.org](http://www.astm.org), retrieved 2009.
- (34) American Society for Testing and Materials, *ASTM G110-92(2009) Standard Practice for Evaluating Intergranular Corrosion Resistance of Heat Treatable Aluminum Alloys by Immersion in Sodium Chloride + Hydrogen Peroxide Solution*, ASTM [www.astm.org](http://www.astm.org), retrieved 2009.
- (35) American Society for Testing and Materials, *ASTM G116-99(2010) Standard Practice for Conducting Wire-on-Bolt Test for Atmospheric Galvanic Corrosion*, ASTM [www.astm.org](http://www.astm.org), retrieved 2010.
- (36) American Welding Society, *AWS A2.4:2007 Standard Symbols for Welding, Brazing, and Nondestructive Examination*, American Welding Society, Miami, FL: 2007.
- (37) American Welding Society, *AWSD1.2/D2.2M:2008 Structural Welding Code – Aluminum* (ISBN: 978-0-87171-664-4), American Welding Society, Miami, FL: 2008.
- (38) Anderson, T.L. *Fracture Mechanics, 3<sup>rd</sup> Edition* (ISBN: 0-8493-1656-1), Taylor & Francis Group, New York, NY: 2005.
- (39) Atlas Specialty Metals, *Technical Note No. 7: Galvanic Corrosion*, Atlas Specialty Metals <http://www.atlassteels.com.au/documents/TN7-0506-Galvanic%20Corrosion.pdf>, retrieved 2011.
- (40) Austal Corporation, “Aluminum – Hull Structure in Naval Applications”, Austal Corporation, <http://www.austal.com/download.cfm?DownloadFile=01D11285-65BF-EBC1-2E7081F6160736A2>, retrieved 2011.
- (41) Beer, F., Johnston, E., DeWolf, J., *Mechanics of Materials*, McGraw-Hill, New York, NY: 2006.
- (42) Bickford, J.H. and Nasser, S. *Handbook of Bolts and Bolted Joints*, Taylor & Francis Group, New York, NY: 1998.
- (43) Bieberich, E.B., Hays, R.A., and Sheetz, A.D. “Comparison of Accelerated Corrosion Test Results to Marine Atmosphere Exposure for U.S. Marine Corps Applications” Naval Surface Warfare Center Carderock Division, CARDIVNSWC-TR-61-99-01, May 1999.
- (44) Bhattacharyya, Rameswar *Dynamics of Marine Vehicles*, John Wiley & Sons, New York, NY: 1978.

- (45) Billhardt, C. F., Nagpal, V., and Altan, T. "A Computer Graphics System for CAD/CAM of Aluminum Extrusion Dies," MS78-957, *Society for Manufacturing Engineers*, 1978.
- (46) Blodgett, O.W. "Controlling Distortion in Design" *Welding Design and Fabrication*, [http://weldingdesign.com/blodgett/wdf\\_68978/index.html](http://weldingdesign.com/blodgett/wdf_68978/index.html), retrieved 2011.
- (47) Blodgett, Omer W. *Design of Welded Structures*, The James F. Lincoln Arc Welding Foundation, Cleveland, OH: 1975.
- (48) Budd, W.I.H., Karve, S.V., de Oliveira, J.G. and Xirouchakis, P.C. SSC-308 "Criteria for Hull-Machinery Rigidity Compatibility" *Ship Structure Committee Report*, 1981.
- (49) Bushfield, Harold, Cruder, Marc, Farley, Rendall, and Towers, Jim. "Marine Aluminum Plate – ASTM Specification B 928 and the Events Leading to its Adoption."
- (50) Cary, Howard B. and Helzer, Scott C. *Modern Welding Technology, 6<sup>th</sup> Edition* (ISBN: 0-13-113029-3), Pearson Prentice Hall: 2005.
- (51) Chen, H.C., Kim, S., Novak, D., and Weems, K. "Slamming Impact Design Loads on Large High Speed Naval Craft" ABS Technical Papers 2008.
- (52) Craig, B.D., Lane, R.A., and Rose, D.H. *Corrosion Prevention and Control: A Program Management Guide for Selecting Materials, Spiral 2*. AMMITIAC, Rome, NY: 2006.
- (53) Davis, J.R., *ASM Specialty Handbook: Aluminum and Aluminum Alloys* (ISBN: 978-0-87170-496-2), ASM International, Ohio: 1993.
- (54) De Silva, Clarence W. *Vibration: Fundamentals and Practice, 2<sup>nd</sup> Edition* (ISBN: 978-0-8493-1987-7), Taylor and Francis Group, New York, NY: 2007.
- (55) Det Norske Veritas, *Rules for Classification of High Speed, Light Craft and Naval Surface Craft, January 2011*, [www.dnv.com](http://www.dnv.com), retrieved January 2011.
- (56) Dwight, John. *Aluminum Design and Construction* (ISBN: 0-419-15710-7). E & FN Spon, New York, NY: 1999.
- (57) Dynamic Materials, "DetaClad® Manufactured at DMC Mt. Braddock Factory" Dynamic Materials, <http://www.dynamicmaterials.com/data/brochures/CladMetalProduction2.pdf>, retrieved 2011.
- (58) Eggington, Wilfred J. and Kobitz, Nat. "The Domain of the Surface Effect Ship" *The Society of Naval Architects and Marine Engineers* November 1975
- (59) ESAB North America, "What is Friction Stir Welding of Aluminum?" ESAB North America, <http://www.esabna.com/us/en/education/knowledge/qa/What-is-friction-stir-welding-of-aluminum.cfm>, retrieved 2011.
- (60) EuroCode 9: "Design of Aluminum Structures."
- (61) Fang Gang, Zhou Jie, and Duszczuk, Jurek. "Effect of Pocket Design on Metal Flow Through Single-Bearing Extrusion Dies to Produce a Thin-Walled Aluminum Profile" *Journal of Materials Processing Technology*, Vol 199 (2008), pp 91-101.
- (62) Fielding, R.A.P. "Computer Aided Design and Manufacture of Extrusion Dies" *Light Metal Age*, April 1972, pg. 22.
- (63) Galvery, W.L. Jr. and Marlow, F.B. *Welding Essentials (2<sup>nd</sup> Edition)*, Industrial Press, Inc., New York, NY: 2007.
- (64) General Motors "GM 9540P: Accelerated Corrosion Test."
- (65) Greene, Eric. SSC-442: "Labor-Saving Passive Fire Protection Systems for Aluminum and Composite Construction" *Ship Structure Committee Report*, 2005.
- (66) Gupta, S.R., *Manufacturing Processes: Welding*, Online Lecture, Indian Institute of Technology Roorkee, <http://nptel.iitm.ac.in/courses/Webcourse-contents/IIT-ROORKEE/MANUFACTURING-PROCESSES/>, retrieved 2011.
- (67) Hatch, J.E. *Aluminum Properties and Physical Metallurgy* (ISBN: 0-87170-176-6), American Society for Metals, Ohio: 1998.
- (68) Heller, S.R., Jr. and Jasper, N.H., "On the Structural Design of Planing Craft," *Quarterly Transactions*, Royal Institution of Naval Architects, July 1960.

- (69) Hobbacher, A. *Fatigue Design of Welded Joints and Components, Recommendations of Working Group XIII-XV* (ISBN: 1-85573-315-3), Victoire Press, Ltd.: 1996.
- (70) Hobson, R.P., "Notes on the Yacht Defender and the Use of Aluminum in Marine Construction," U.S. Naval Institute Proceedings, Vol. 23, No. 82, 1897, pg. 249-282; Vol. 23, No. 83, 1897, pg. 523-562.
- (71) Hoggard, M.M. and Jones, J.P., "Examining Pitch, Heave, and Accelerations of Planing Craft Operating in a Seaway", presented at High Speed Surface Craft Symposium, Brighton, England, June 1980.
- (72) Hosford, William F. and Caddell, Robert M. *Metal Forming: Mechanics and Metallurgy* (ISBN: 978-0-521-88121-0), Cambridge University Press, New York, NY: 2008.
- (73) Hughes, O. *Ship Structural Design: A Rationally-Based, Computer-Aided Optimization Approach*, SNAME, Jersey City, NJ: 1988.
- (74) International Maritime Organization, *International Code of Safety for High Speed Craft, 2000 (2008 Edition)* (ISBN: 978-92-801-4240-2), International Maritime Organization, London: 2008.
- (75) International Maritime Organization, *Safety of Life at Sea, Consolidated Edition 2009*, International Maritime Organization: 2009.
- (76) Jefferson, T.B. and Woods, Gorham *Metals and How to Weld Them, 2<sup>nd</sup> Edition*, The James F. Lincoln Arc Welding Foundation, Cleveland, OH: 1962.
- (77) Jordan, C.R., and Cochran, C.S. SSC-272: "In-Service Performance of Structural Details," *Ship Structure Committee Report*, 1978.
- (78) Jordan, C.R., and Knight, L.T. SSC 294: "Further Survey of In-Service Performance of Structural Details" *Ship Structure Committee Report*, 1980.
- (79) Kissell, J. Randolph and Ferry, Robert L. *Aluminum Structures: A Guide to Their Specifications and Design, 2<sup>nd</sup> Edition* (ISBN: 978-0-471-01965-7), John Wiley & Sons, Inc., New York, NY: 2002.
- (80) Koebel, J.G. "Structural Design for High-Speed Craft Part One" *Professional Boat Builder*, Oct/Nov 2000.
- (81) Koebel, J.G. "Structural Design for High-Speed Craft Part Two" *Professional Boat Builder*, Dec/Jan 2001.
- (82) Lamb, G.R. "High-Speed, Small Naval Vessel Technology Development Plan," Total Ship Systems Directorate Technology Projection Report, NSWCCD, NSWCCD-20-TR-2003/09.
- (83) Lamb, Thomas (Ed). *Ship Design and Construction*, SNAME, Jersey City, NJ: 2003.
- (84) Mansour, Alaa and Liu, Donald, *The Principles of Naval Architecture Series: Strength of Ships and Ocean Structures*, SNAME, Jersey City, NJ: 2008.
- (85) Masubuchi, Koichi *Analysis of Welded Structures* (ISBN: 0-08-0261299), Pergamon Press, New York, NY: 1980.
- (86) Mazzolani, Federico M. *Aluminum Alloy Structures, Second Edition* (ISBN: 0-419-17770-1), E & FN Spon, London, UK: 1995.
- (87) McGuire, S.C. *Aluminum: Its Alloys and Their Use in Ship Construction*, Transactions of the Society of Naval Architects and Marine Engineers, pg. 69-97: 1895.
- (88) Metallic Fusion, "Location of Elements of a Welding Symbol," <http://www.metallicfusion.com/images/misc/welding%20chart.jpg>, retrieved 2011.
- (89) Muckle, W. *The Design of Aluminum Alloy Ships' Structures* (ISBN: ), The Aluminum Development Association, London, UK: 1963.
- (90) Nagpal, V. and Altan T. "Design and Manufacturing of Extrusion Dies by Computer" *Journal of Mechanical Working Technology*, Vol 1 (No. 2), Nov 1977, pg. 183.
- (91) Nagpal, V., Billhardt C.F., Gagne R., and Altan T. "Automated Design of Extrusion Dies by Computer" *International Aluminum Extrusion Technology Seminar Proceedings*, Nov 1977.
- (92) Nagpal, V., Billhardt C.F., and Altan T. "Lubricated Extrusion of 'T' Sections from Aluminum, Titanium, and Steel Using Computer-Aided Techniques," *Journal of Engineering for Industry (Transactions of ASME)*, Vol 101, Aug 1979, pg. 319.



- (93) National Physical Laboratory, "Guides to Good Practice in Corrosion Control: Stress Corrosion Cracking"
- (94) National Shipbuilding Research Program, "Results of Enhanced Fire Protection Material Systems, NSRP Report ASE-932006, 2001.
- (95) Naval Sea Systems Command, *DDS 130-2: Structural Design and Analysis of Helicopter Handling Decks*, DDS 130-2, 1 July 1984.
- (96) Naval Sea Systems Command, *Requirements for Non-Destructive Testing Methods*, Technical Publication T-9074-AS-GIB-101/271.
- (97) Naval Sea Systems Command, *Structural Design Manual for Naval Surface Ships*, NAVSEA 0900-LP-097-4010.
- (98) Naval Surface Warfare Center, Unknown Title (Sea State Chart), NSWCCD-23-TM-1999/16.
- (99) Neuber, H., *Theory of Notch Stresses, 2<sup>nd</sup> Edition*, Springer-Verlag, Berlin (1961 translation): 1958.
- (100) Nicholas, E.D., "Development in the friction-stir-welding of metals" *ICAA-6: 6<sup>th</sup> International Conference on Aluminum Alloys, Toyohashi, Japan*: 1998.
- (101) Nishida, M. *Stress Concentration*, Mori Kita Press, Tokyo: 1976.
- (102) Özdemýr, Ayla, "Locking Devices, Keys, Springs, Rivets, and Welding" METU Department of Mechanical Engineering, [http://www.me.metu.edu.tr/courses/me114/Lecture/loc\\_key\\_spr\\_riv.htm](http://www.me.metu.edu.tr/courses/me114/Lecture/loc_key_spr_riv.htm), retrieved 2011.
- (103) Paulling, J.R. (Ed.), *The Principles of Naval Architecture Series: Strength of Ships and Ocean Structures*, SNAME, Jersey City, NJ: 2008.
- (104) Pilkey, W.D. *Formulas for Stress, Strain, and Structural Matrices, 2<sup>nd</sup> Edition*, Wiley, Hoboken, NJ: 2005.
- (105) Pilkey, W.D. and Pilkey D.F. *Peterson's Stress Concentration Factors*, John Wiley & Sons, Inc., Hoboken, NJ: 2008.
- (106) Post, C.T. "The Strong Link That Ties CAD to CAM", *Iron Age*, 22 Aug 1977, pg. 29.
- (107) Purnell C. and Males D. "Extrusion Die Design by Computer" *Light Metal Age*, April 1980, pg. 12.
- (108) Savin, G.N. *Stress Concentration Around Holes*, Pergamon Press, London: 1961.
- (109) Savin, G.N. and Tulchii, V.I., *Handbook on Stress Concentration*, Higher Education Publishing House: 1976.
- (110) Savitsky, D. and Brown, P.W., "Procedures for Hydrodynamic Evaluation of Planing Hulls in Smooth and Rough Water, *Marine Technology*, Vol. 13, No. 4, Oct. 1976.
- (111) Sharp, M.L. *Behavior and Design of Aluminum Structures*, McGraw-Hill, New York, NY: 1993.
- (112) Sharp, M. L. and Nordmark, G.E. *Fatigue Strength of Welded Tubular Aluminum Truss*. Journal of the Structural Division, Proceedings A.S.C.E.: 1977.
- (113) Sharp, M. L., Nordmark, G.E. , and Menzemmer, C.C. *Fatigue Design of Aluminum Components and Structures*, McGraw-Hill, New York, NY:1996.
- (114) Sheetz, Nathan C. *GMAW Weld Area Diagram*, Wikimedia Commons, retrieved 2010.
- (115) Sielski, R.S. SSC-452: "Aluminum Structure Design and Fabrication Guide" *Ship Structure Committee Report*, 2007.
- (116) Skillingberg, M. "The Aluminum Industry Continues Support for the Marine Market New Temper Definitions Published" The Aluminum Association, 2004
- (117) Society of Automotive Engineers, *Fatigue Design Handbook*, SAE, Warrenton, PA: 1988.
- (118) Society of Naval Architects and Marine Engineers, "Aluminum Fire Protection Guidelines, SNAME T&R Bulletins 2-21, New York, NY: 1974.
- (119) Spencer, J.S. "Structural Design of Aluminum Crewboats" *Marine Technology*, Vol 12, No, July 1975.
- (120) Stephens, Ralph I., Fatemi, Ali, Stephens, Robert R., and Fuch, Henry O. *Metal Fatigue in Engineering* (ISBN: 0-471-51059-9), John Wiley & Sons, Inc., New York, NY: 2001.
- (121) Stiles, Daniel J., LaMontagne, Kevin. "Aluminum Alloy Sensitization Data Visualization and Analysis." Proceedings *DoD Corrosion Conference*, 2009.

- (122) Stone, K.F. SSC-439: “Comparative Structural Requirements for High Speed Craft” *Ship Structure Committee Report*, 2005.
- (123) Storch, R.L., Hammon, C.P., Bunch, H.M. and Moore, R.C. *Ship Production*, SNAME, Jersey City, NJ: 2007.
- (124) Taggart, Robert (Ed.), *Ship Design and Construction*, SNAME, New York, NY: 1980.
- (125) Sweet Haven Publishing Services, “Fundamentals of Professional Welding, v. 1.0”  
<http://www.sweethaven.com/sweethaven/bldgconst/welding/lessonmain.asp?lesnum=3&modnum=3>,  
 retrieved, 2011.
- (126) The Welding Institute, “Residual Stresses” TWI,  
<http://www.twi.co.uk/content/ksrhl001.html>,  
 retrieved 2011.
- (127) United States Military, *MIL-J-24445A Joint, Bimetallic Bonded, Aluminum to Steel*, ASSIST,  
<https://assist.daps.dla.mil/quicksearch/>, retrieved 2011.
- (128) United States Military, *MIL-R-5674F Rivets, Structural, Aluminum Alloy, Titanium Columbium Alloy General Specification For*, ASSIST,  
<https://assist.daps.dla.mil/quicksearch/>, retrieved 2011.
- (129) United States Military, *MIL-STD-1399 Section 302, Interface Standard for Shipboard Systems: Weather Environment*, ASSIST,  
<https://assist.daps.dla.mil/quicksearch/>, retrieved 2011.
- (130) United States Military, *MIL-STD-1689A Fabrication, Welding, and Inspection of Ships Structure*, ASSIST,  
<https://assist.daps.dla.mil/quicksearch/>, retrieved 2011.
- (131) Weman, Klas *Welding Process Handbook* (ISBN: 1-85573-689-6), Woodhead Publishing Ltd., Cambridge, England: 2003.
- (132) Wimprey Offshore, *Basic Guide on the Use of Aluminum in Offshore Structures*, Wimprey Offshore: 1990.
- (133) Wong, Catherine and Field Alicia. “Thermal Stability of Selected 5000 Series Al Alloys” Presentation at TMS 2006.
- (134) Young, W.C. and Budynas, R.G. *Roark’s Formulas for Stress and Strain, Seventh Edition*, McGraw-Hill, New York, NY: 2002.





## SHIP STRUCTURE COMMITTEE LIAISON MEMBERS

### LIAISON MEMBERS

American Society of Naval Engineers	Captain Dennis K. Kruse (USN Ret.)
Bath Iron Works	Mr. Steve Tarpy
Colorado School of Mines	Dr. Stephen Liu
Edison Welding Institute	Mr. Rich Green
International Maritime Organization	Mr. Igor Ponomarev
Int'l Ship and Offshore Structure Congress	Dr. Alaa Mansour
INTERTANKO	Mr. Dragos Rauta
Massachusetts Institute of Technology	
Memorial University of Newfoundland	Dr. M. R. Haddara
National Cargo Bureau	Captain Jim McNamara
National Transportation Safety Board - OMS	Dr. Jack Spencer
Office of Naval Research	Dr. Yapa Rajapaksie
Oil Companies International Maritime Forum	Mr. Phillip Murphy
Samsung Heavy Industries, Inc.	Dr. Satish Kumar
United States Coast Guard Academy	Commander Kurt Colella
United States Merchant Marine Academy	William Caliendo / Peter Web
United States Naval Academy	Dr. Ramswar Bhattacharyya
University of British Columbia	Dr. S. Calisal
University of California Berkeley	Dr. Robert Bea
Univ. of Houston - Composites Eng & Appl.	
University of Maryland	Dr. Bilal Ayyub
University of Michigan	Dr. Michael Bernitsas
Virginia Polytechnic and State Institute	Dr. Alan Brown
Webb Institute	Prof. Roger Compton

## RECENT SHIP STRUCTURE COMMITTEE PUBLICATIONS

Ship Structure Committee Publications on the Web - All reports from SSC 1 to current are available to be downloaded from the Ship Structure Committee Web Site at URL:

<http://www.shipstructure.org>

SSC 445 – SSC 393 are available on the SSC CD-ROM Library. Visit the National Technical Information Service (NTIS) Web Site for ordering hard copies of all SSC research reports at

URL: <http://www.ntis.gov>

SSC Report Number	Report Bibliography
SSC 463	Marine Composites NDE, Inspection Techniques for Marine Composite Construction Greene, E 2012
SSC 462	Review of Current Practices of Fracture Repair Procedures for Ship Structures Wang, G, Khoo, E., ABS Corporate Technology 2012
SSC 461	Structural Challenges Faced By Arctic Ships, Kendrick A., Daley C. 2011
SSC 460	Effect of Welded Properties on Aluminum Structures, Sensharma P., Collette M., Harrington J. 2011
SSC 459	Reliability-Based Performance Assessment of Damaged Ships, Sun F., Pu Y., Chan H., Dow R.S., Shahid M., Das P.K. 2011
SSC 458	Exact Mapping of Residual Stress in Ship Hull Structures by Use of Neutron Diffraction Das. S. Kenno S. 2009
SSC 457	Investigation of Plastic Limit States for Design of Ship Hull Structures, Daley C., Hermanski G. 2009
SSC 456	Buckling Collapse Testing on Friction Stir Welded Aluminum Stiffened Plate Structures, Paik J.K. 2009
SSC 455	Feasibility, Conceptual Design and Optimization of a Large Composite Hybrid Hull, Braun D., Pejdic M. 2008
SSC 454	Ultimate Strength and Optimization of Aluminum Extrusions, Collette M., Wang C. 2008
SSC 453	Welding Distortion Analysis Of Hull Blocks Using Equivalent Load Method Based On Inherent Strain, Jang C.D. 2008
SSC 452	Aluminum Structure Design and Fabrication Guide, Sielski R.A. 2007
SSC 451	Mechanical Collapse Testing on Aluminum Stiffened Panels for Marine Applications, Paik J.K. 2007
SSC 450	Ship Structure Committee: Effectiveness Survey, Phillips M.L., Buck R., Jones L.M. 2007