

FIRST
PROGRESS REPORT
(Project SR-110)
on
**AN INVESTIGATION OF THE INFLUENCE OF DEOXIDATION AND
CHEMICAL COMPOSITION ON NOTCHED-BAR PROPERTIES OF
SEMIKILLED SHIP STEEL**

by
H. M. Banta, R. H. Frazier and C. H. Lorig
BATTELLE MEMORIAL INSTITUTE
Under Bureau of Ships Contract NObs-50020
(Index No. NS-011-078)

Transmitted through
**NATIONAL RESEARCH COUNCIL'S
COMMITTEE ON SHIP STEEL**
Advisory to
SHIP STRUCTURE COMMITTEE
under
**Bureau of Ships, Navy Department
Contract NObs-50148**

Division of Engineering and Industrial Research
National Academy of Sciences - National Research Council
Washington, D. C.

JUNE 27, 1952

NATIONAL RESEARCH COUNCIL

2101 CONSTITUTION AVENUE, WASHINGTON 25, D. C.

COMMITTEE ON SHIP STEEL

OF THE

DIVISION OF ENGINEERING AND INDUSTRIAL RESEARCH

June 27, 1952

Dear Sir:

Attached is Report Serial No. SSC-49 entitled "An Investigation of the Influence of Deoxidation and Chemical Composition on Notched-Bar Properties of Semi-killed Ship Steel". This report has been submitted by the contractor as the Final Report on Contract NObs-50020 (Index No. NS-011-078) between the Bureau of Ships, Department of the Navy and Battelle Memorial Institute. Since the project (SR-110) is continuing under a new contract (NObs-53239, Index No. NS-011-078), this report is being issued as the First Progress Report covering the preliminary phase of the investigation.

The report has been reviewed and acceptance recommended by representatives of the Committee on Ship Steel, Division of Engineering and Industrial Research, NRC, in accordance with the terms of the contract between the Bureau of Ships, Department of the Navy and the National Academy of Sciences (Contract NObs-50148, Index No. NS-731-036).

Very truly yours,

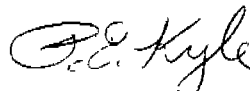

P. E. Kyle, Chairman
Committee on Ship Steel

FIRST PROGRESS REPORT

on

**AN INVESTIGATION OF THE INFLUENCE OF DEOXIDATION AND
CHEMICAL COMPOSITION ON NOTCHED-BAR PROPERTIES OF
SEMIKILLED SHIP STEEL**

to

**SHIP STRUCTURE COMMITTEE
via
Bureau of Ships
Department of the Navy**

**Final Report on Contract NObs 50020
Index No. NS-C11-078**

by

H. M. Banta, R. H. Frazier, and C. H. Lorig

BATTELLE MEMORIAL INSTITUTE

TABLE OF CONTENTS

	<u>Page</u>
INTRODUCTION	1
REPRODUCIBILITY OF LABORATORY STEELS	3
INFLUENCE OF FINISHING TEMPERATURE AND GRAIN SIZE	13
REPRODUCIBILITY OF LABORATORY STEELS FINISHED AT 1850°F	17
INFLUENCE OF CARBON, MANGANESE, PHOSPHORUS, SULPHUR, SILICON AND VANADIUM	21
Carbon	23
Manganese	30
Silicon	34
Phosphorus	34
Sulphur	37
Vanadium	37
SUMMARY	40
REFERENCES	41
APPENDIX	42

LIST OF FIGURES

	Page
FIGURE 1. LONGITUDINAL SECTION OF 200-POUND SEMIKILLED LABORATORY INGOT OF CLASS A TYPE STEEL . . .	5
FIGURE 2. NAVY TEAR-TEST SPECIMEN	10
FIGURE 3. TYPICAL KEYHOLE CHARPY IMPACT DATA FOR LABORATORY CLASS A AND B STEELS FINISHED AT 1650°F	12
FIGURE 4. MICROSTRUCTURE OF CLASS A AND CLASS B STEELS FINISHED AT 1650, 1750, and 1850°F. .	15
FIGURE 5. INFLUENCE OF CARBON CONTENT UPON THE TRANSITION TEMPERATURE OF CLASS A TYPE LABORATORY STEELS	29
FIGURE 6. INFLUENCE OF CARBON CONTENT UPON THE TRANSITION TEMPERATURE OF CLASS B TYPE LABORATORY STEELS	31
FIGURE 7. INFLUENCE OF MANGANESE CONTENT UPON THE TRANSITION TEMPERATURE OF LABORATORY STEELS	32
FIGURE 8. RELATIONSHIP BETWEEN YIELD STRENGTH AND TRANSITION TEMPERATURE WHEN YIELD STRENGTH WAS VARIED BY CHANGING THE CARBON CONTENT .	33
FIGURE 9. RELATIONSHIP BETWEEN YIELD STRENGTH AND TRANSITION TEMPERATURE WHEN YIELD STRENGTH WAS VARIED BY CHANGING THE MANGANESE CONTENT	33
FIGURE 10. INFLUENCE OF SILICON CONTENT UPON THE TRANSITION TEMPERATURE OF CLASS A TYPE LABORATORY STEELS	35
FIGURE 11. INFLUENCE OF SILICON CONTENT UPON THE TRANSITION TEMPERATURE OF CLASS B TYPE LABORATORY STEELS	35
FIGURE 12. INFLUENCE OF PHOSPHORUS CONTENT UPON THE TRANSITION TEMPERATURE OF CLASS A TYPE LABORATORY STEELS	36
FIGURE 13. INFLUENCE OF PHOSPHORUS CONTENT UPON THE TRANSITION TEMPERATURE OF CLASS B TYPE LABORATORY STEELS	36
FIGURE 14. INFLUENCE OF SULPHUR CONTENT UPON THE TRANSITION TEMPERATURE OF CLASS A TYPE LABORATORY STEELS	38
FIGURE 15. INFLUENCE OF SULPHUR CONTENT UPON THE TRANSITION TEMPERATURE OF CLASS B TYPE LABORATORY STEELS	38
FIGURE 16. INFLUENCE OF VANADIUM CONTENT UPON THE TRANSITION TEMPERATURE OF CLASS A AND CLASS B TYPE LABORATORY STEELS	39
FIGURE 17. RELATIONSHIP BETWEEN YIELD STRENGTH AND TRANSITION TEMPERATURE WHEN THE YIELD STRENGTH WAS VARIED BY CHANGING THE VANADIUM CONTENT	39

LIST OF TABLES

Page

TABLE 1.	CHEMICAL ANALYSIS OF CLASS A AND CLASS B TYPE STEELS MADE TO STUDY THE REPRODUCIBILITY OF LABORATORY STEELS - FINISHING TEMPERATURE 1650°F.....	6
TABLE 2.	TENSILE AND TRANSITION-TEMPERATURE CHARACTERISTICS OF CLASS A AND CLASS B TYPE STEELS IN REPRODUCIBILITY STUDY OF LABORATORY STEELS FINISHED AT 1650°F.....	8
TABLE 3.	CHEMICAL ANALYSIS AND PROPERTIES OF STEELS MADE TO STUDY THE INFLUENCE OF FINISHING TEMPERATURE.....	14
TABLE 4.	CHEMICAL ANALYSIS OF CLASS A AND CLASS B TYPE STEELS MADE TO STUDY THE REPRODUCIBILITY OF LABORATORY STEELS - FINISHING TEMPERATURE 1850°F.....	18
TABLE 5.	TENSILE AND TRANSITION-TEMPERATURE CHARACTERISTICS OF CLASS A AND CLASS B TYPE STEELS MADE TO STUDY THE REPRODUCIBILITY OF LABORATORY STEELS-FINISHING TEMPERATURE 1850°F.....	19
TABLE 6.	NOMINAL COMPOSITIONS OF CLASS A AND CLASS B TYPE STEELS AND RANGE OF COMPOSITION STUDIED.....	22
TABLE 7.	COMPOSITION AND MECHANICAL PROPERTIES OF LABORATORY PLATES SHOWING THE EFFECT OF <u>CARBON</u> AND <u>MANGANESE</u> - FINISHING TEMPERATURE WAS 1650°F...	24
TABLE 8.	COMPOSITION AND MECHANICAL PROPERTIES OF LABORATORY PLATES SHOWING THE EFFECT OF <u>CARBON</u> AND <u>MANGANESE</u> - FINISHING TEMPERATURE WAS 1850°F...	25
TABLE 9.	COMPOSITION AND MECHANICAL PROPERTIES OF LABORATORY PLATES SHOWING THE EFFECT OF <u>PHOSPHORUS</u> AND <u>SULPHUR</u> - FINISHING TEMPERATURE WAS 1850°F.....	26
TABLE 10.	COMPOSITION AND MECHANICAL PROPERTIES OF LABORATORY PLATES SHOWING THE EFFECT OF <u>SILICON</u> FINISHING TEMPERATURE WAS 1850°F.....	27
TABLE 11.	COMPOSITION AND MECHANICAL PROPERTIES OF LABORATORY PLATES SHOWING EFFECT OF <u>VANADIUM</u> FINISHING TEMPERATURE WAS 1850°F.....	28

FIRST PROGRESS REPORT

on

AN INVESTIGATION OF THE INFLUENCE OF DEOXIDATION AND
CHEMICAL COMPOSITION ON NOTCHED-BAR PROPERTIES OF
SEMIKILLED SHIP STEEL

to

SHIP STRUCTURE COMMITTEE

via

Bureau of Ships
Department of the Navy

by

H. M. BANTA, R. H. FRAZIER, and C. H. LORIG

INTRODUCTION

Extensive research, conducted under the auspices of the Ship Structure Committee, has revealed that the transition temperature of the plate steel, the temperature at which the steel changes from ductile to brittle behavior, is associated with the service performance of the steel in welded ship structures. Subsequent studies have indicated that commercial steels produced for the same specifications and made by similar processes can differ widely in notched-bar properties, although their chemical composition and tensile properties are similar. Further consideration of this problem revealed the need for research to determine the cause for these differences in behavior. It appears that, by

first determining and then by controlling the pertinent factors influencing the transition-temperature characteristics, ship plate could be produced with improved properties.

With the above objects in view, the Bureau of Ships on behalf of the Ship Structure Committee under the guidance of the Committee on Ship Steel of the National Research Council established a research project, Contract NObs 50020, for the purpose of studying the influence of chemical composition and deoxidation upon the transition characteristics and tensile properties of the American Bureau of Shipping Class A and Class B steels. For convenience of the readers, the ABS classification of structural steel plates is as follows:

	<u>Class A</u>	<u>Class B</u>	<u>Class C*</u>
Carbon, max. per cent	-	0.23	0.25
Manganese, per cent	±	0.60 to 0.90	0.60 to 0.90
Phosphorus, max. per cent	0.04	0.04	0.04
Sulfur, max. per cent	0.05	0.05	0.05
Silicon, per cent	-	-	0.15 to 0.30
Plate thickness,	1/2" or less	1/2" to 1", inc.	over 1"
Tensile strength, psi.	59,000/70,000	59,000/70,000	59,000/70,000
Yield point, min. psi.	32,000	32,000	32,000
Elongation in 8", (for 3/4" plate) min. per cent	<u>1,500,000</u>	<u>1,500,000</u>	<u>32,000</u>
	Tensile Strength	Tensile Strength	Tensile Strength
Elongation in 2", min, per cent	22	22	22

* Plate steels produced to the requirements of Class C shall be made with fine grain practice.

(1,2)

Since it had been shown that gage is an important

variable affecting transition temperature, plate thickness was a constant

in this investigation on deoxidation and composition. All steels for this project were tested at a plate thickness of 3/4 inch.

The terms "Class A type" and "Class B type" steels are used frequently in this report to emphasize the fact that some of the materials differ in composition, strength, or thickness from the ABS classifications. The deviations exist because Class A steels were tested as 3/4-inch plates and because carbon, silicon, manganese, phosphorus, and vanadium were varied outside the normal ranges.

This report presents information obtained in experimental work performed between October 1, 1949, and September 30, 1950. It is the final or summary report for work done on Contract NObs 50020. The investigation is continuing under Contract NObs 53239.

REPRODUCIBILITY OF LABORATORY STEELS

since it was proposed to conduct most of this investigation in the laboratory, using small ingots poured from induction-furnace melts, it was first necessary to determine whether or not semikilled laboratory heats could be produced having uniform tensile properties and transition-temperature characteristics from heat to heat. To answer this question, a series of five Class A and five Class B steels were made and tested.

This series of steels was prepared from 200-pound induction-furnace melts; the charge was melted under an atmosphere of argon to insure low, uniform nitrogen content of the same order found in commercial ship plate. After the charge was melted and the desired

temperature was obtained, the melt was partly deoxidized by an addition of 9 pounds of silicomanganese per ton. This addition was made to insure consistent recovery of the subsequent ferromanganese and ferrosilicon additions made to obtain the required chemical analysis. Carbon, in the form of graphite, was added just prior to tapping to meet the specification. The entire heat was poured directly into a 6 x 6-inch big-end-up mold and the ingot capped with a steel plate when necessary. The longitudinal section of an ingot produced by this procedure is shown in Figure 1.

The ingots were processed by heating to 2250^oF., followed by forging to slabs 1-3/4 inches thick by 6 inches wide. After reheating to 2250^oF., the slabs were rolled to 7/8-inch gage, using reduction of approximately 1/6 inch per pass. In order to insure a uniform finishing temperature, the 7/8-inch sections were immediately recharged in a furnace held at 1650^oF. After 20 minutes or more in the 1650^oF. furnace, the plates were reduced to 3/4 inch in one pass. Following this final pass, the plates were placed on edge on a brick floor, with a brick separating each plate, and allowed to air cool.

Drilling for chemical analysis were taken from the top and bottom of each ingot following rolling. These analyses are shown in Table 1. The carbon contents of the Class A heats are in the range of 0.19 per cent to 0.26 per cent, with eight of the ten values falling between 0.20 and 0.24 per cent. The

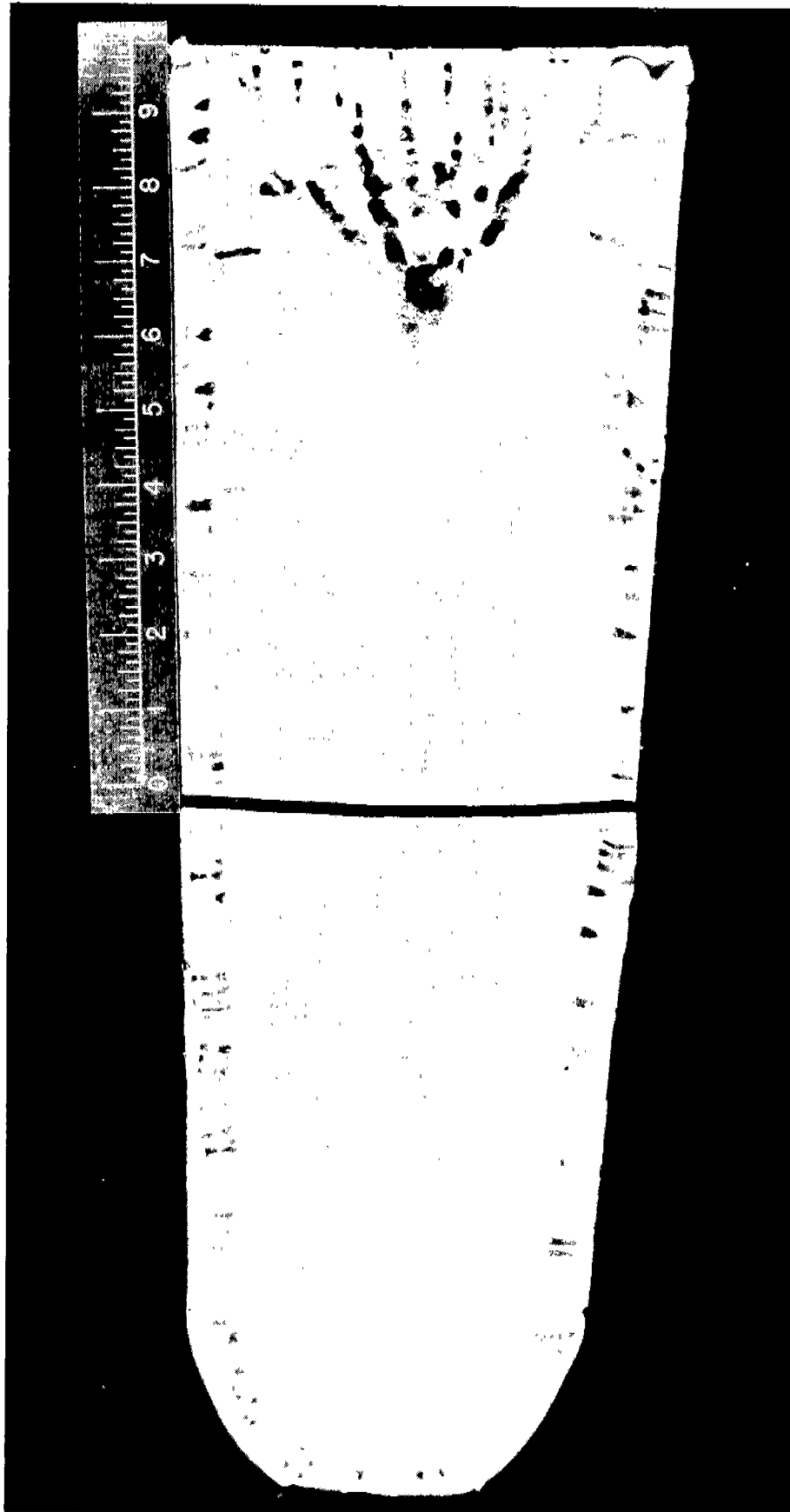

67287

FIGURE I. LONGITUDINAL SECTION OF 200-POUND SEMIKILLED LABORATORY INGOT OF CLASS A TYPE STEEL

TABLE 1. CHEMICAL ANALYSIS OF CLASS A AND CLASS B TYPE
STEELS MADE TO STUDY THE REPRODUCIBILITY OF
LABORATORY STEELS. FINISHING TEMPERATURE -
1650^o F.

Identification of Steel			Chemical Analysis, %					
Grade of Steel	Heat No.	Location of Sample	C	Mn	P	S	Si	N
Class "A"	A-1	Top	0.21	0.52	0.009	0.026	0.04	0.004
		Bottom	0.21	0.52	0.008	0.028	0.03	0.004
"	A-2	Top	0.23	0.47	0.021	0.029	0.08	0.004
		Bottom	0.26	0.47	0.017	0.030	0.06	0.003
"	A-3	Top	0.23	0.48	0.013	0.029	0.04	0.003
		Bottom	0.24	0.46	0.013	0.032	0.04	0.003
"	A-4	Top	0.20	0.44	0.012	0.025	0.04	0.003
		Bottom	0.23	0.45	0.014	0.029	0.03	0.003
"	A-5	Top	0.19	0.49	0.013	0.024	0.04	0.004
		Bottom	0.23	0.48	0.014	0.030	0.03	0.003
Class "B"	B-2	Top	0.16	0.87	0.017	0.028	0.03	0.004
		Bottom	0.17	0.88	0.014	0.028	0.04	0.002
"	B-3	Top	0.17	0.93	0.020	0.028	0.03	0.005
		Bottom	0.18	0.93	0.019	0.028	0.04	0.003
"	B-4	Top	0.18	0.91	0.018	0.029	0.03	0.005
		Bottom	0.18	0.89	0.017	0.029	0.02	0.004
"	B-5	Top	0.18	0.99	0.015	0.029	0.07	0.004
		Bottom	0.18	1.03	0.019	0.029	0.09	0.004
"	B-6	Top	0.17	0.92	0.014	0.025	0.06	0.006
		Bottom	0.20	0.89	0.015	0.029	0.04	0.003

manganese contents of these same heats all fall within the range of 0.44 to 0.52 per cent. The phosphorus, silicon, and nitrogen contents are comparable with those of commercial steels of this grade.

The carbon content of all the Class B steels falls between 0.16 and 0.18 per cent, with the exception of one value for the bottom of one ingot, which is 0.20 per cent. The manganese content of four of these heats is between 0.87 and 0.93 per cent, while the fifth heat is higher, being 0.99 and 1.03 per cent at the top and at the bottom, respectively. The other constituents are comparable with those of the Class A steels.

Duplicate standard plate tensile specimens, using the full thickness of the plate, were prepared from each heat. The data from these specimens, together with tear-test data and the transition temperature determined from keyhole Charpy specimens, are shown in Table 2.

It will be noted that the tensile properties of the Class A steels are extremely uniform, with the ultimate strength falling between 58,900 psi. and 61,600 psi., and the yield strength between 37,050 and 38,800 psi.

The tensile strength of the Class B steels falls between 57,900 psi. and 63,900 psi., and the yield strength between 36,200 and 42,800 psi. The ductility, as indicated by the elongation, is essentially the same for both classes of steel and in the range expected for this type of steel.

TABLE 2. TENSILE AND TRANSITION-TEMPERATURE CHARACTERISTICS OF CLASS A AND CLASS B TYPE STEELS IN REPRODUCIBILITY STUDY OF LABORATORY STEELS FINISHED AT 1650°F.

Grade of Steel	Heat No.	Tensile Properties			Tear Test-Properties			Transition Temperature, °F.	Charpy Impact (2) Transition Temperature, °F.	
		Yield Strength, psi.	Tensile Strength, psi.	Elong. in 8", %	Max. Load, Lbs.	Energy (1) Start, Ft. -Lbs.	Energy to (1) Propagate, Ft. -Lbs			
Class "A"	A-1	37,050	61,600	21.5*	38,760	840	790	50	-2	
"	"	A-2	38,800	66,000	32.5	38,160	820	840	45	-16
"	"	A-3	37,700	59,500	30.0	37,110	790	590	55	+16
"	"	A-4	37,650	58,900	33.5	37,340	790	660	50	0
"	"	A-5	38,600	59,100	29.0	37,610	880	650	50	+10
Class "B"	B-2	35,700	57,900	31.0	38,670	910	700	40	-16	
"	"	B-3	36,200	61,500	31.0	40,630	960	700	40	-32
"	"	B-4	38,300	59,900	30.5	40,260	990	710	40	-25
"	"	B-5	40,900	63,900	30.5	43,790	950	660	40	-34
"	"	B-6	42,800	63,200	32.5	42,270	1000	690	0	-38

Note:- *Poor surface quality.

(1) Average energy of the four ductile specimens broken 10°F. above the transition temperature.

(2) Temperature at which the impact strength is 20 ft.-lbs. Charpy Keyhole Notch.

The transition temperature of these steels was determined by two methods: first, by using the Navy tear test, and second, from notched-bar impact data obtained from keyhole Charpy specimens.

The tear tests were made using the type of specimen and procedure described by Kahn and Imbembo^(3,4), with the exception that, in rating the appearance of the specimen, only the first 1-1/2 inches of the fracture were considered, since the last 1/2 inch tends to be of the cleavage type, even when the remainder is quite ductile. In no case, however, did this change in procedure alter the results of transition temperature-determinations.

The tear-test specimen, which is 3 x 5 inches long, the latter dimension being in the direction of rolling, utilizes the full thickness of the plate. This test specimen is shown in Figure 2. The specimen is subjected to tensile loading through a pin-and-shackle arrangement while submerged in a liquid bath for temperature control. The transition temperature was defined as the highest temperature at which one or more specimens exhibited a fracture area of less than 50 per cent of the ductile-shear type.

From Table 2 it will be noted that the tear-test transition temperature of the Class A steels is quite uniform, four of the steels falling between 50°F., and 55°F., and one at 45°F. In the case of the Class B steels, four have tear-test transition temperatures of 40°F. The fifth steel, Heat B-6, however is entirely out of line, having a transition temperature of 0°F. Subsequent examination of this heat revealed that the as-rolled grain size was appreciably finer, as compared with the other heats in this series. A careful study of the melting, forging, and rolling records failed to satisfactorily explain this difference.

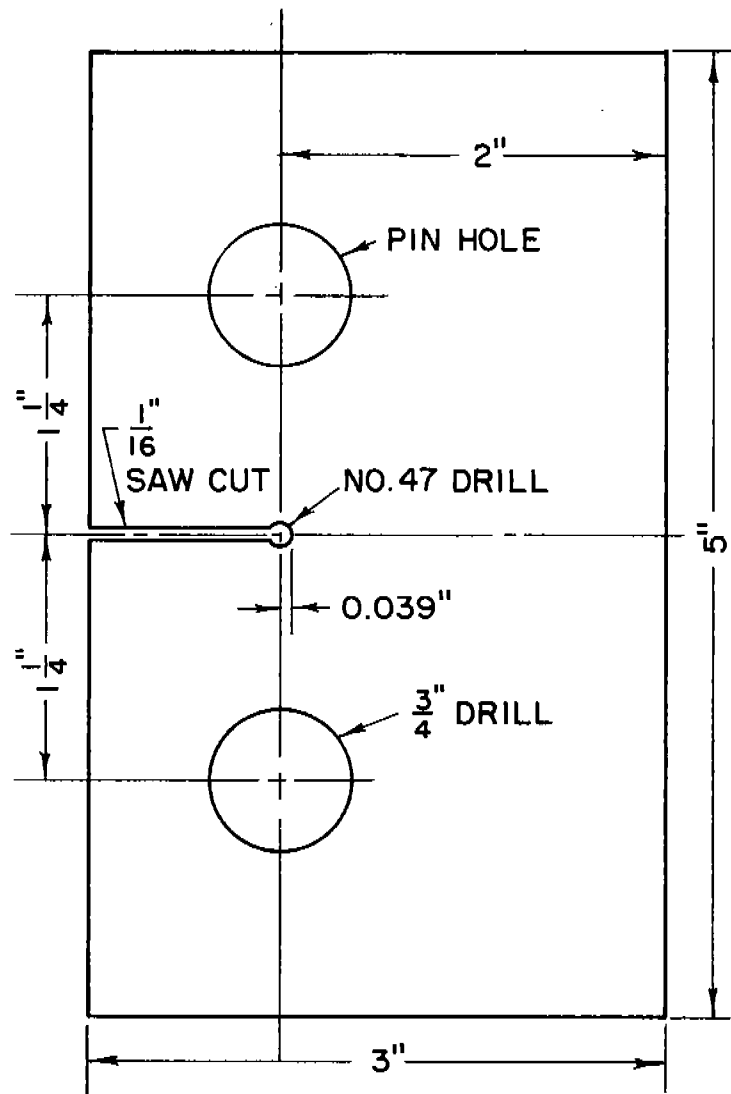

FIGURE 2. NAVY TEAR-TEST SPECIMEN UTILIZING FULL PLATE THICKNESS

The transition temperature was determined from the keyhole Charpy impact data by taking the temperature at the point on the temperature-Charpy impact curve where it crossed the 20-foot-pound level. In using this procedure, it was realized that it is open to question; however, no altogether satisfactory procedure has been agreed upon by those working in this field. A typical example of the Charpy impact data is shown in Figure 3. All Charpy specimens were taken with the long axis in the direction of rolling and were notched in the direction perpendicular to the original surface of the plate.

From Table 2, it will be observed that the Charpy impact transition temperatures of the Class A steels all fall between -2°F. and -16°F. , with the exception of Heat A-2, which was -16°F. This heat also had the lowest transition temperature of the group, as determined by the tear test. (See Appendix for complete data.)

The Charpy impact transition of the Class B steels fall between -16°F. and -38°F. Heat B-6, which has the lowest Charpy transition temperature, also had the lowest tear-test transition temperature. The Charpy test, however, in this case, did not indicate the marked difference between Heat B-6 and the other heats in this group as the tear test did.

From the above review of the data in Table 2, it appears that 200-pound semikilled laboratory heats can be produced with

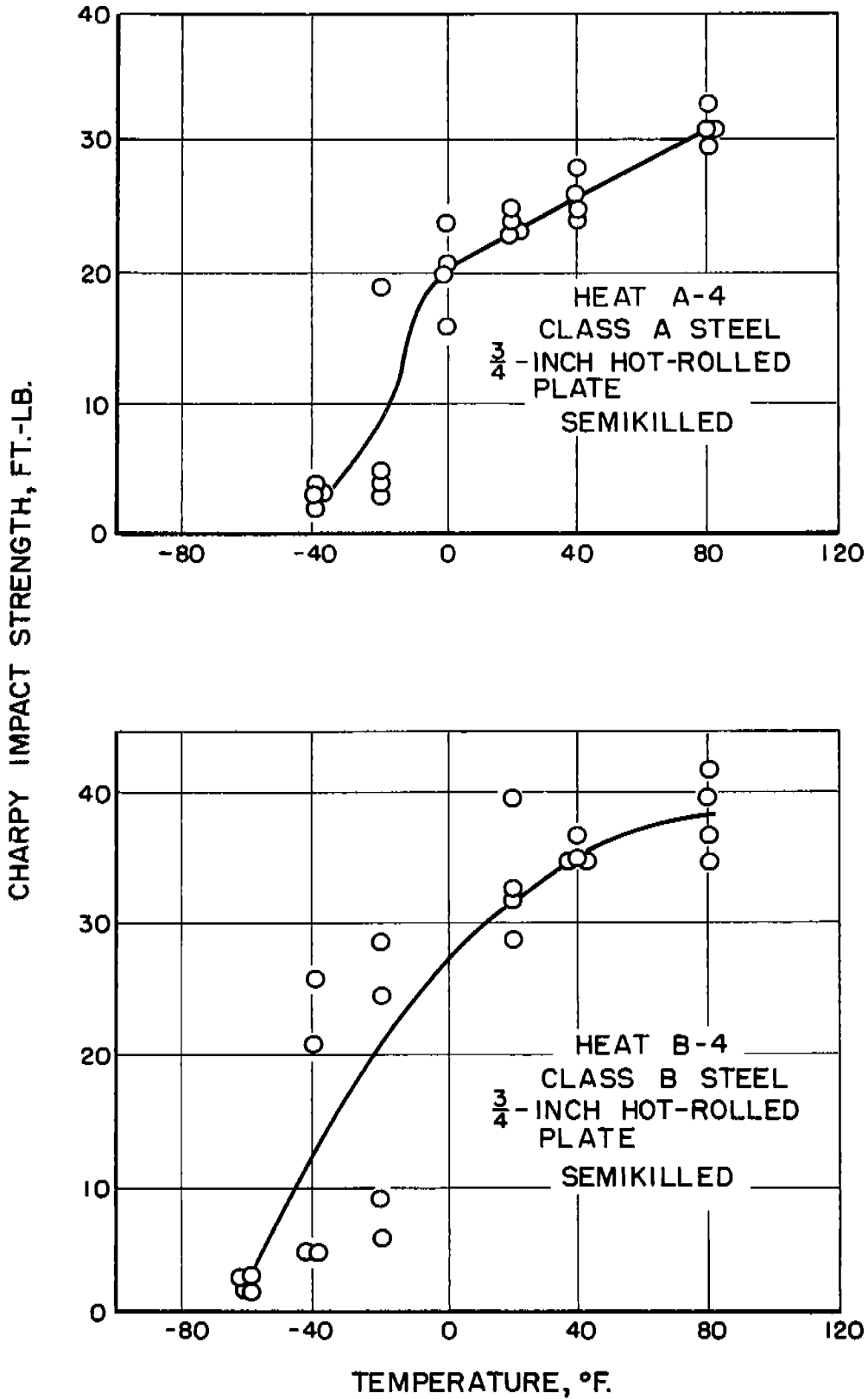

FIGURE 3. TYPICAL KEYHOLE CHARPY IMPACT DATA FOR LABORATORY CLASS A AND B STEELS FINISHED AT 1650°F.

sufficient reproducibility to justify their use in studying the influence of chemical composition and deoxidation upon the characteristics of ship plate.

INFLUENCE OF FINISHING TEMPERATURE AND GRAIN SIZE

Since the fine as-rolled grain size of Heat B-6, as compared with the other heats in this series, B-2 to B-5, inclusive, appeared to have a marked influence upon the transition temperature as determined by the tear test, it was decided to further investigate this subject. In order to eliminate the possibilities of variables other than grain size, as established by the finishing temperature, a heat of Class A steel was forged to a 1-3/4-inch slab and then divided into three parts. These parts were then processed to 3/4-inch plate, as previously described, with the exception that each piece was heated to a different temperature prior to the final pass through the rolling mill, these temperatures being 1650° F., 1750° F., and 1850° F. The object was to vary the ferritic grain size by changing the finishing temperature. A heat of Class B steel was processed in a similar manner.

The chemical analyses of these two steels, together with other pertinent data, are shown in Table 3*. It will be noted that there is a fair correlation between the finishing temperature and as-rolled grain size, as shown by the photomicrographs in Figure 4.

* Complete data in Appendix

TABLE 3. CHEMICAL ANALYSIS AND PROPERTIES OF STEELS MADE TO STUDY THE INFLUENCE OF FINISHING TEMPERATURE

Grade of Steel	Heat No.	Composition, %					
		C	Mn	P	S	SI	N
A	A6424	0.21	0.42	0.014	0.029	0.02	0.004
B	A6365	0.19	0.95	0.021	0.028	0.06	0.004

Grade of Steel	Heat No.	Finishing Temp., °F.	Yield Strength, psi.	Tensile Strength, psi.	Yield Strength/Tensile Strength Ratio, %	Elong. in 8", %	Tear-Test Transition Temp., °F.
A	A6424	1650	37,950	57,200	66.3	31.5	+50
"	"	1750	34,650	57,600	60.1	31.0	+60
"	"	1850	34,000	58,250	58.4	29.0	+95
B	A6365	1650	40,150	64,000	62.8	29.0	+10
"	"	1750	38,650	63,700	60.7	32.0	+20
"	"	1850	38,150	63,850	59.8	31.5	+40

(Class A Steel)

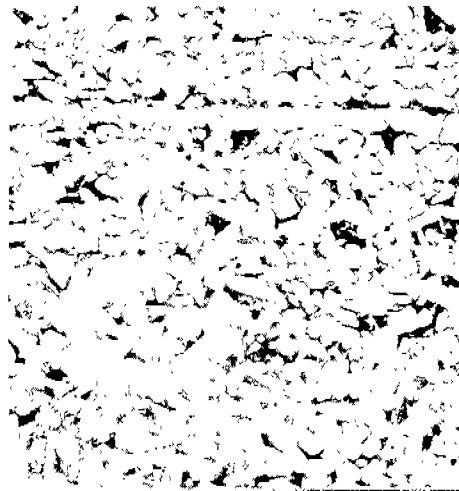

(Class B Steel)

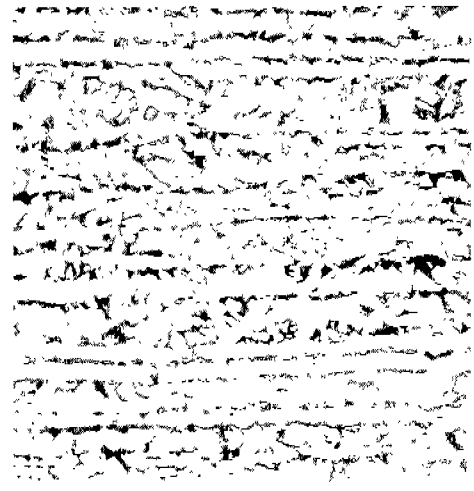

1650°F

68674

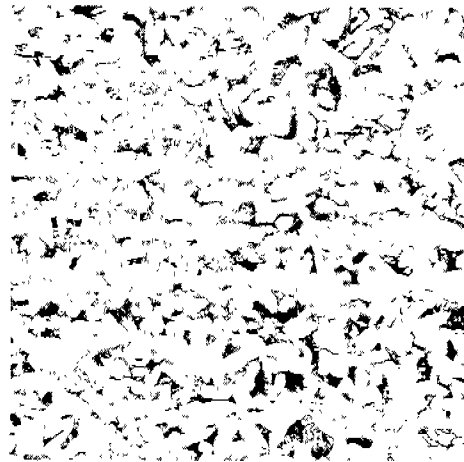

1650°F

68673

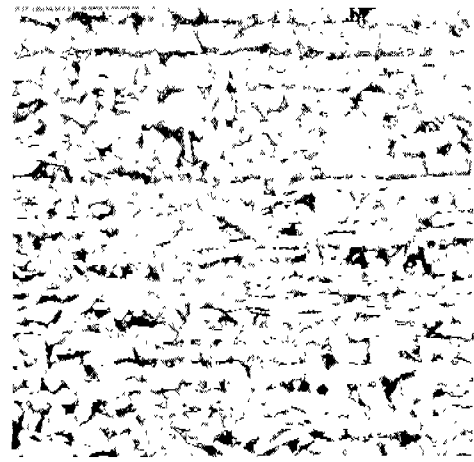

1750°F

68671



1750°F

68672

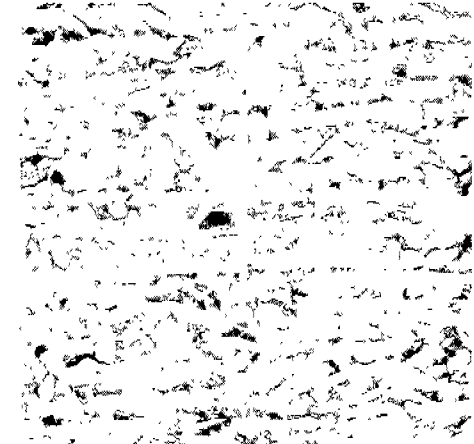

1850°F

68675

1850°F

68669

FIGURE 4. MICROSTRUCTURE OF CLASS A AND CLASS B STEELS FINISHED AT 1650, 1750, AND 1850°F. X 100

As would be expected, the finishing temperature did, in the case of both grades of steel, influence the yield strength-tensile strength ratio, this ratio decreasing slightly with increased finishing temperature. This effect was most noticeable in the Class A steel.

The most pronounced effect of varying the finishing temperature was noted in the transition temperature, which increased as the finishing temperature was raised. Of the two steels, the Class A appeared to be the more sensitive; increasing the finishing temperature from 1650^oF. to 1850^oF. raised the transition temperature 45^oF. Under similar conditions, the transition temperature of the Class B steel was raised 30^oF.

These results indicate that the transition temperature is influenced to a marked extent by the finishing temperature. It also appears that the Class A steel is more sensitive to changes in the finishing temperature than the Class B steel, but additional data are required to confirm this point. A comparison of the data in Table 3 with results from commercial steels of these two grades showed that the higher finishing temperature, 1850^oF., produced yield strength to ultimate strength ratios most similar to those of the commercial product. It was decided therefore, to use the 1850^oF. finishing temperature in the remainder of this investigation, provided consistent properties could be obtained.

REPRODUCIBILITY OF LABORATORY STEELS
FINISHED AT 1850° F.

Before continuing this investigation, it was considered desirable to repeat the series previously made to determine the reproducibility of laboratory steels, using the same melting and processing procedure as previously described, with the exception that the finishing temperature was raised from 1650° F. to 1850° F. and a slightly heavier reduction was taken in the final pass. The slabs were reduced from 9/10 inch to 3/4 inch in the last pass following reheating to 1850° F.

The chemical analysis of this second series of five Class A and five Class B steels is listed in Table 4, analyses being shown for the top and bottom of each ingot following rolling to 3/4-inch plate.

In the Class A steels, the carbon content in four of the heats is between 0.21 and 0.23 per cent, and the manganese in all five heats is within the limits of 0.44 and 0.49 per cent. The carbon and manganese contents of the Class B steels are between 0.19 and 0.23 per cent and 0.74 to 0.83 per cent, respectively. The remaining elements, phosphorus, sulphur, silicon, and nitrogen, all fall within relatively narrow limits and are present to about the same extent as in commercial steels.

The tensile properties of these steels, together with the transition temperatures, as determined both by the tear test and from keyhole Charpy impact data, are listed in Table 5*.

* See Appendix for complete data.

TABLE 4. CHEMICAL ANALYSIS OF CLASS A AND CLASS B TYPE STEELS MADE TO STUDY THE REPRODUCIBILITY OF LABORATORY STEELS. FINISHING TEMPERATURE ~ 1850°F.

Identification of Steel		Location of Sample	Composition, %					
Grade of Steel	Heat No.		C	Mn	P	S	Si	N
Class A	A6555	Top	0.22	0.47	0.016	0.025	0.07	0.004
		Bottom	0.22	0.48	0.017	0.024	0.06	0.003
Class A	A6556	Top	0.23	0.45	0.017	0.025	0.06	0.004
		Bottom	0.23	0.44	0.018	0.025	0.05	0.005
Class A	A6587	Top	0.20	0.45	0.011	0.023	0.07	0.005
		Bottom	0.25	0.45	0.011	0.025	0.06	0.003
Class A	A6650	Top	0.22	0.45	0.012	0.024	0.04	0.005
		Bottom	0.22	0.48	0.012	0.022	0.04	0.003
Class A	A6705	Top	0.22	0.49	0.016	0.025	0.05	0.004
		Bottom	0.21	0.49	0.017	0.025	0.06	0.004
Class B	A6557	Top	0.22	0.76	0.017	0.025	0.07	0.006
		Bottom	0.22	0.75	0.016	0.025	0.07	0.004
Class B	A6584	Top	0.20	0.78	0.014	0.021	0.07	0.005
		Bottom	0.21	0.75	0.014	0.023	0.07	0.004
Class B	A6588	Top	0.23	0.80	0.011	0.024	0.07	0.005
		Bottom	0.20	0.79	0.012	0.024	0.06	0.004
Class B	A6641	Top	0.20	0.79	0.016	0.023	0.04	0.004
		Bottom	0.19	0.83	0.016	0.022	0.04	0.004
Class B	A6651	Top	0.19	0.75	0.017	0.024	0.01	0.006
		Bottom	0.19	0.74	0.017	0.023	0.01	0.005

TABLE 5. TENSILE AND TRANSITION-TEMPERATURE CHARACTERISTICS OF CLASS A AND CLASS B-TYPE STEELS MADE TO STUDY THE REPRODUCIBILITY OF LABORATORY STEELS. FINISHING TEMPERATURE, - 1850°F.

Identification of Steel		Tensile Properties				Tear-Test Properties			Charpy Impact(2)		
Grade of Steel	Heat No.	Yield Strength, psi. Upper*	Yield Strength, psi. Lower**	Tensile Strength, psi.	Elong. in 8", %	Maximum Load, Lbs.	Energy(1) to Start, Ft.-Lbs.	Energy to(1) Propagate, Ft.-Lbs.	Transition Temp., °F.	Transition Temp., °F.	
Class A	A6555	38,850	36,050	62,700	27.5	37,920	810	750	80	+12	
"	"	A6556	37,950	35,000	61,600	31.0	38,230	790	690	70	+4
"	"	A6587	35,400	34,450	61,650	29.5	35,920	690	680	100	+12
"	"	A6650	35,600	34,250	60,550	28.0	36,740	820	640	70	+25
"	"	A6705	37,050	35,900	63,000	24.5	36,340	760	580	60	+5
Class B	A6557	36,200	35,500	61,700	30.0	40,250	960	910	70	-13	
"	"	A6584	36,350	35,400	61,950	30.5	39,450	850	700	70	-6
"	"	A6588	35,550	34,900	62,350	28.0	39,010	940	780	70	-20
"	"	A6641	36,550	35,350	62,850	24.0	39,910	890	660	80	-25
"	"	A6651	37,200	35,700	62,300	28.5	38,590	880	720	70	-24

Footnotes on following page.

Footnotes for Table 5

Note:- Keyhole notch used in Charpy specimens.

* Upper yield strength - the maximum strength before "drop of the beam".

** Lower yield strength - lowest strength during "drop of the beam".

(1) Average energy of tests made at 10^oF. higher than transition temperature.

(2) Temperature at which impact strength is 20 ft.-lbs.

The tensile properties of both classes are fairly uniform and in the range expected for steels of this composition.

The tear-test transition temperatures of the Class A steels are all between 60° F. and 80° F. with one exception, Heat A6587, which has a transition temperature of 100° F. The data from the keyhole Charpy specimens did not show this difference in behavior of Heat A6587, as indicated by the tear test. Using the Charpy impact data, the transition temperatures of these Class A steels range from 4° F. to 25° F.

Of the five Class B steels, four have a tear-test transition temperature of 70° F. and one 80° F. The keyhole Charpy data indicate transition temperatures from -6° F. to -24° F.

From the above data, it may be safely concluded that 200-pound semikilled ingots of both Class A and Class B steels can be made in the laboratory with sufficient reproducibility that they can be used for investigating the influence of chemical composition and processing upon steel quality.

INFLUENCE OF CARBON, MANGANESE, PHOSPHORUS,
SULPHUR, SILICON, AND VANADIUM

The influence of chemical composition in both Class A and Class B type steels was studied by varying the carbon, manganese, phosphorus, sulphur, silicon, and vanadium contents within the limits shown in Table 6. Only one constituent in each heat was varied from the nominal composition as listed in Table 6, so that the effect could be readily determined.

TABLE 6. NOMINAL COMPOSITION OF CLASS A AND CLASS B TYPE
STEELS AND RANGE OF COMPOSITION STUDIED

Range of Composition Studied in Class A and Class B Type Steels

Grade of Steel	Chemical Composition, %					
	C	Mn	P	S	Si	V
Class A	0.12/0.37	0.26/1.31	0.009/0.058	0.022/0.046	0.03/0.31	0.06/0.20
Class B	0.14/0.35	0.22/1.48	0.015/0.054	0.021/0.046	0.02/0.29	0.08/0.20

Nominal Composition of Class A and Class B Type Steels

Grade of Steel	Chemical Composition, %					
	C	Mn	P	S	Si	N
Class A	0.25	0.45	0.015	0.030	0.05	0.004
Class B	0.19	0.85	0.015	0.030	0.05	0.004

Also, in order to continue the investigation of the effect of finishing temperature, while studying the influence of chemical composition, the first series of eight heats made to determine the effect of carbon and manganese contents was finished at 1650^oF., while the remainder, including additional heats for studying the effect of carbon and manganese, was finished at 1850^oF.

The chemical analyses, tensile properties, and transition temperatures of the first eight heats, finished at 1650^oF., are listed in Table 7*.

Similar data for the fifteen Class A and fifteen Class B type heats made to study the effect of the six constituents listed above and finished at 1850^oF. are shown in Tables 8 to 11, inclusive, the heats being grouped in these tables according to the constituent being studied.

Carbon

The effect of carbon content upon the tear-test transition temperature for Class A type steel is shown in Figure 5. These data show that the transition temperature increases rapidly as the carbon content is raised. For the steels finished at 1850^oF., an increase in carbon content from 0.16 to 0.35 per cent raised the transition temperature from 60^oF. to 120^oF. The carbon content has a similar influence upon the steels

* See Appendix for complete data.

TABLE 7. COMPOSITION AND MECHANICAL PROPERTIES OF LABORATORY PLATES SHOWING THE EFFECT OF CARBON AND MANGANESE⁽¹⁾ - THE FINISHING TEMPERATURE WAS 1650 F

Identification of Steel		Location of Sample	Chemical Analysis						Tensile Properties			Tear Test Properties			Charpy Impact Transition Temp, (3) F	
			Composition, per cent						Yield Strength, psi	Tensile Strength, psi	Elong. in 8", per cent	Maximum Load, lbs	Energy to Start Fracture, (2) ft-lbs	Energy to Propagate Fracture, (2) ft-lbs		Transition Temp, F
			C	Mn	P	S	Si	N								
<u>(Carbon Series)</u>																
Class A	A6293	Top	0.12	0.49	0.019	0.025	0.04	0.005	35,600	51,750	36.0	37,610	1280	1270	+10	-9
		Bottom	0.12	0.48	0.015	0.025	0.04	0.004								
Class A	A6294	Top	0.37	0.53	0.018	0.024	0.03	0.004	43,450	72,950	26.0	39,810	620	480	+90	+77
		Bottom	0.36	0.55	0.018	0.025	0.03	0.004								
Class B	A6155	Top	0.22	0.87	0.022	0.028	0.02	0.005	41,150	62,100	31.5	41,660	980	830	+20	-45
		Bottom	0.18	0.86	0.019	0.025	0.02	0.006								
Class B	A6292	Top	0.35	1.02	0.019	0.024	0.04	0.004	50,650	84,300	23.0	47,380	690	560	+80	+43
		Bottom	0.33	1.02	0.020	0.024	0.04	0.006								
<u>(Manganese Series)</u>																
Class A	A6295	Top	0.20	0.29	0.018	0.025	0.03	0.004	36,000	56,050	33.0	35,810	790	690	+90	+28
		Bottom	0.20	0.29	0.018	0.026	0.03	0.004								
Class A	A6296	Top	0.19	1.30	0.020	0.024	0.07	0.006	45,800	72,400	28.0	47,390	1160	720	+20	-66
		Bottom	0.22	1.27	0.019	0.024	0.05	0.004								
Class B	A6159	Top	0.25	0.37	0.021	0.026	0.01	0.005	36,550	56,900	31.5	37,480	990	760	+60	+21
		Bottom	0.18	0.38	0.015	0.023	0.01	0.004								
Class B	A6306	Top	0.16	1.48	0.023	0.024	0.09	0.006	45,550	69,050	30.5	47,800	1310	860	+20	-75
		Bottom	0.19	1.40	0.021	0.025	0.04	0.004								

* Upper Yield Strength - The maximum strength before "drop of the beam".

(1) Plates were hot rolled to 3/4-inch thickness.

(2) Average energy of the tests made at 10 F higher than transition temperature.

(3) Temperature at which impact strength is 20 ft-lbs.

B
A
T
T
L
E
M
E
M
O
R
I
A
L
I
N
S
T
I
T
U
T
E

TABLE 8. COMPOSITION AND MECHANICAL PROPERTIES OF LABORATORY PLATES SHOWING THE EFFECT OF CARBON AND MANGANESE⁽¹⁾. THE FINISHING TEMPERATURE WAS 1850 F

B
A
T
T
L
E
M
E
M
O
R
I
A
L
I
N
S
T
I
T
U
T
E

Identification of Steel		Location of Sample	Chemical Analysis						Tensile Properties				Tear Test Properties			Charpy Impact ⁽³⁾ Transition Temp, F	
Grade of Steel	Heat No.		Composition, per cent						Yield Strength, psi		Tensile Strength, psi	Elong. in 8", per cent	Maximum Load, lbs	Energy ⁽²⁾ to Start Fracture, ft-lbs	Energy ⁽²⁾ to Propagate Fracture, ft-lbs		Transition Temp, F
			C	Mn	P	S	Si	N	Upper*	Lower*							
<i>(Carbon Series)</i>																	
Class A	A6539	Top	0.16	0.42	0.018	0.028	0.02	0.004	31,850	30,750	53,300	30.5	35,820	930	690	60	+10
		Bottom	0.15	0.41	0.017	0.027	<0.01	0.003									
Class A	A6596	Top	0.35	0.50	0.016	0.023	0.06	0.003	41,300	38,550	72,900	21.0	36,470	520	570	120	+75
		Bottom	0.34	0.48	0.015	0.023	0.07	0.004									
Class B	A6586	Top	0.14	0.77	0.011	0.024	0.07	0.004	33,000	32,000	54,400	28.0	38,490	1270	1110	40	-24
		Bottom	0.14	0.76	0.011	0.023	0.07	0.003									
Class B	A6597	Top	0.33	0.79	0.017	0.024	0.06	0.004	40,900	40,100	75,100	24.5	40,970	640	610	90	+19
		Bottom	0.31	0.81	0.017	0.024	0.07	0.004									
<i>(Manganese Series)</i>																	
Class A	A6589	Top	0.22	0.26	0.016	0.024	0.07	0.004	34,050	33,050	58,400	29.5	35,180	820	670	100	+36
		Bottom	0.22	0.26	0.016	0.025	0.09	0.005									
Class A	A6598	Top	0.24	1.31	0.019	0.026	0.07	0.004	42,850	42,150	74,200	23.0	45,490	950	830	70	-60
		Bottom	0.24	1.24	0.014	0.026	0.07	0.004									
Class B	A6590	Top	0.19	0.22	0.015	0.027	0.04	0.004	33,100	31,450	55,100	30.5	34,110	840	740	90	+26
		Bottom	0.19	0.22	0.015	0.026	0.05	0.003									
Class B	A6599	Top	0.21	1.46	0.013	0.023	0.07	0.004	43,850	43,400	72,350	24.5	46,820	970	850	60	-38
		Bottom	0.20	1.47	0.017	0.022	0.06	0.004									

* Upper Yield Strength - The maximum strength before "drop of the beam".

Lower Yield Strength - Lowest strength during "drop of the beam".

(1) Plates were hot rolled to 3/4-inch thickness.

(2) Average energy of tests made at 10 F higher than transition temperature.

(3) Temperature at which impact strength is 20 ft-lbs.

TABLE 9. COMPOSITION AND MECHANICAL PROPERTIES OF LABORATORY PLATES SHOWING THE EFFECT OF PHOSPHORUS AND SULFUR⁽¹⁾ - THE FINISHING TEMPERATURE WAS 1850 F

Identification of Steel		Location of Sample	Chemical Analysis						Tensile Properties			Tear Test Properties				Charpy Impact ⁽³⁾ Transition Temp, F	
			Composition, per cent						Yield Strength, psi		Tensile Strength, psi	Elong. in 8", per cent	Maximum Load, lbs	Energy ⁽²⁾ to Start Fracture, ft-lbs	Energy ⁽²⁾ to Propagate Fracture, ft-lbs		Transition Temp, F
Grade of Steel	Heat No.		C	Mn	P	S	Si	N	Upper*	Lower*							
<i>(Phosphorus Series)</i>																	
Class A	A6135	Top	0.23	0.49	0.012	0.022	0.04	0.004	34,750	33,100	59,100	28.5	35,380	710	700	80	-1
		Bottom	0.22	0.47	0.009	0.025	0.03	0.004									
Class A	A6652	Top	0.19	0.49	0.038	0.020	0.02	0.007	37,350	36,250	64,000	23.5	38,730	850	580	110	+20
		Bottom	0.24	0.49	0.038	0.024	0.02	0.005									
Class A	A6706	Top	0.28	0.47	0.058	0.028	0.06	0.004	39,650	38,500	67,250	21.0	38,120	730	640	110	+50
		Bottom	0.22	0.49	0.049	0.026	0.07	0.004									
Class B	A6638	Top	0.16	0.80	0.016	0.018	0.05	0.007	36,000	34,150	61,650	28.5	38,820	940	690	60	-26
		Bottom	0.18	0.75	0.015	0.022	0.05	0.004									
Class B	A6653	Top	0.20	0.76	0.046	0.023	0.06	0.005	38,600	36,550	64,750	25.0	39,710	880	750	90	-11
		Bottom	0.19	0.76	0.045	0.023	0.06	0.004									
Class B	A6655	Top	0.13	0.81	0.052	0.016	0.10	0.010	40,800	38,250	67,450	23.5	41,150	880	640	110	+10
		Bottom	0.19	0.81	0.054	0.022	0.04	0.005									
<i>(High-Sulfur Steels)</i>																	
Class A	A6647	Top	0.20	0.53	0.017	0.038	0.07	0.006	38,600	35,550	62,000	26.0	36,390	700	670	60	+10
		Bottom	0.22	0.54	0.016	0.046	0.07	0.005									
Class B	A6646	Top	0.20	0.83	0.017	0.046	0.08	0.005	37,400	36,150	62,150	28.5	39,090	900	720	50	-24
		Bottom	0.19	0.81	0.016	0.044	0.07	0.005									

* Upper Yield Strength - The maximum strength before "drop of the beam".

Lower Yield Strength - Lowest strength during "drop of the beam".

(1) Plates were hot rolled to 3/4-inch thickness.

(2) Average energy of tests made at 10 F higher than transition temperature.

(3) Temperature at which the impact strength is 20 ft-lbs.

B
A
T
T
L
E
M
E
M
O
R
I
A
L
I
N
S
T
I
T
U
T
E

TABLE 10. COMPOSITION AND MECHANICAL PROPERTIES OF LABORATORY PLATES SHOWING THE EFFECT OF SILICON⁽¹⁾ - THE FINISHING TEMPERATURE WAS 1850 F

Identification of Steel		Location of Sample	Chemical Analysis						Tensile Properties				Tear Test Properties			Charpy Impact ⁽³⁾ Transition Temp, F	
			Composition, per cent						Yield Strength, psi		Tensile Strength, psi	Elong. in B*, per cent	Maximum Load, lbs	Energy ⁽²⁾ to Start Fracture, ft-lbs	Energy ⁽²⁾ to Propagate Fracture, ft-lbs		Transition Temp, F
Grade of Steel	Heat No.	C	Mn	P	S	Si	N	Upper*	Lower*								
(Silicon Series)																	
Class A	A6602	Top	0.24	0.51	0.011	0.019	0.02	0.004	33,550	32,950	60,000	30.5	36,290	770	690	80	+14
		Bottom	0.22	0.51	0.010	0.017	0.02	0.003									
Class A	A6594	Top	0.22	0.48	0.019	0.027	0.11	0.003	37,100	35,700	62,450	30.0	38,270	810	830	80	-7
		Bottom	0.21	0.48	0.017	0.027	0.11	0.003									
Class A	A6657	Top	0.23	0.48	0.016	0.021	0.15	0.004	34,200	33,650	63,350	26.5	38,140	840	650	70	-2
		Bottom	0.23	0.49	0.016	0.021	0.14	0.004									
Class A	A6696	Top	0.25	0.55	0.015	0.023	0.31	0.005	37,400	36,650	67,200	26.0	40,390	800	740	70	-28
		Bottom	0.24	0.54	0.016	0.023	0.31	0.005									
Class B	A6603	Top	0.21	0.84	0.016	0.022	0.03	0.004	37,550	36,850	64,900	23.0	39,090	870	730	80	-29
		Bottom	0.21	0.84	0.018	0.022	0.02	0.003									
Class B	A6595	Top	0.20	0.83	0.017	0.024	0.13	0.004	38,350	36,150	63,400	27.5	40,870	1020	720	40	-43
		Bottom	0.20	0.80	0.017	0.024	0.12	0.004									
Class B	A6695	Top	0.20	0.84	0.016	0.024	0.16	0.004	38,450	36,700	64,300	26.5	42,120	940	710	30	-57
		Bottom	0.19	0.83	0.014	0.025	0.16	0.004									
Class B	A6697	Top	0.19	0.85	0.015	0.023	0.29	0.005	39,050	37,800	66,950	29.5	42,390	970	730	60	-29
		Bottom	0.19	0.86	0.016	0.023	0.29	0.005									

* Upper Yield Strength - The maximum strength before "drop of the beam".

Lower Yield Strength - Lowest strength during "drop of the beam".

(1) Plates were hot rolled to 3/4-inch thickness.

(2) Average energy of tests made at 10 F higher than transition temperature.

(3) Temperature at which impact strength is 20 ft-lbs.

**TABLE 11. COMPOSITION AND MECHANICAL PROPERTIES OF LABORATORY PLATES SHOWING
THE EFFECT OF VANADIUM⁽¹⁾ - THE FINISHING TEMPERATURE WAS 1850 F**

Grade of Steel	Heat No.	Location of Sample	Chemical Analysis							Tensile Properties			Tear Test Properties			Charpy Impact ⁽³⁾ Transition Temp, F		
			Composition, per cent							Yield Strength, psi		Tensile Strength, psi	Elong. in 8", per cent	Maximum Load, lbs	Energy ⁽²⁾ to Start Fracture, ft-lbs		Energy ⁽²⁾ to Propagate Fracture, ft-lbs	Transition Temp, F
			C	Mn	P	S	Si	N	V	Upper*	Lower*							
(Vanadium Series)																		
Class A	A6642	Top	0.22	0.50	0.016	0.022	0.07	0.003	0.06	44,950	40,850	67,900	23.0	39,080	650	620	80	+15
		Bottom	0.21	0.49	0.015	0.023	0.09	0.004	0.10									
Class A	A6368	Top	0.21	0.48	0.019	0.026	0.04	0.003	0.09	45,300	44,450	68,000	25.0	40,760	640	670	100	+10
		Bottom	0.23	0.49	0.016	0.027	0.03	0.002	0.09									
Class A	A6366	Top	0.19	0.49	0.015	0.022	0.06	0.002	0.20	57,300	53,900	78,400	20.0	45,800	520	510	160	+73
		Bottom	0.23	0.50	0.015	0.028	0.04	0.002	0.18									
Class B	A6643	Top	0.20	0.82	0.016	0.023	0.10	0.003	0.08	43,900	42,550	68,550	22.0	42,210	800	760	70	-25
		Bottom	0.19	0.81	0.016	0.023	0.08	0.003	0.08									
Class B	A6644	Top	0.18	0.83	0.016	0.021	0.08	0.004	0.12	51,250	48,900	73,200	18.5	44,100	690	780	100	-20
		Bottom	0.20	0.82	0.016	0.022	0.09	0.003	0.12									
Class B	A6645	Top	0.18	0.80	0.016	0.023	0.10	0.003	0.20	63,000	60,250	85,050	15.5	52,060	530	550	160	+70
		Bottom	0.20	0.78	0.017	0.021	0.10	0.002	0.19									

* Upper Yield Strength - The maximum strength before "drop of the beam".

Lower Yield Strength - Lowest strength during "drop of the beam".

(1) Plates were hot rolled to 3/4-inch thickness.

(2) Average energy of tests made at 10 F higher than transition temperature.

(3) Temperature at which impact strength is 20 ft-lbs.

B A T T L E M E M O R I A L I N S T I T U T E

158

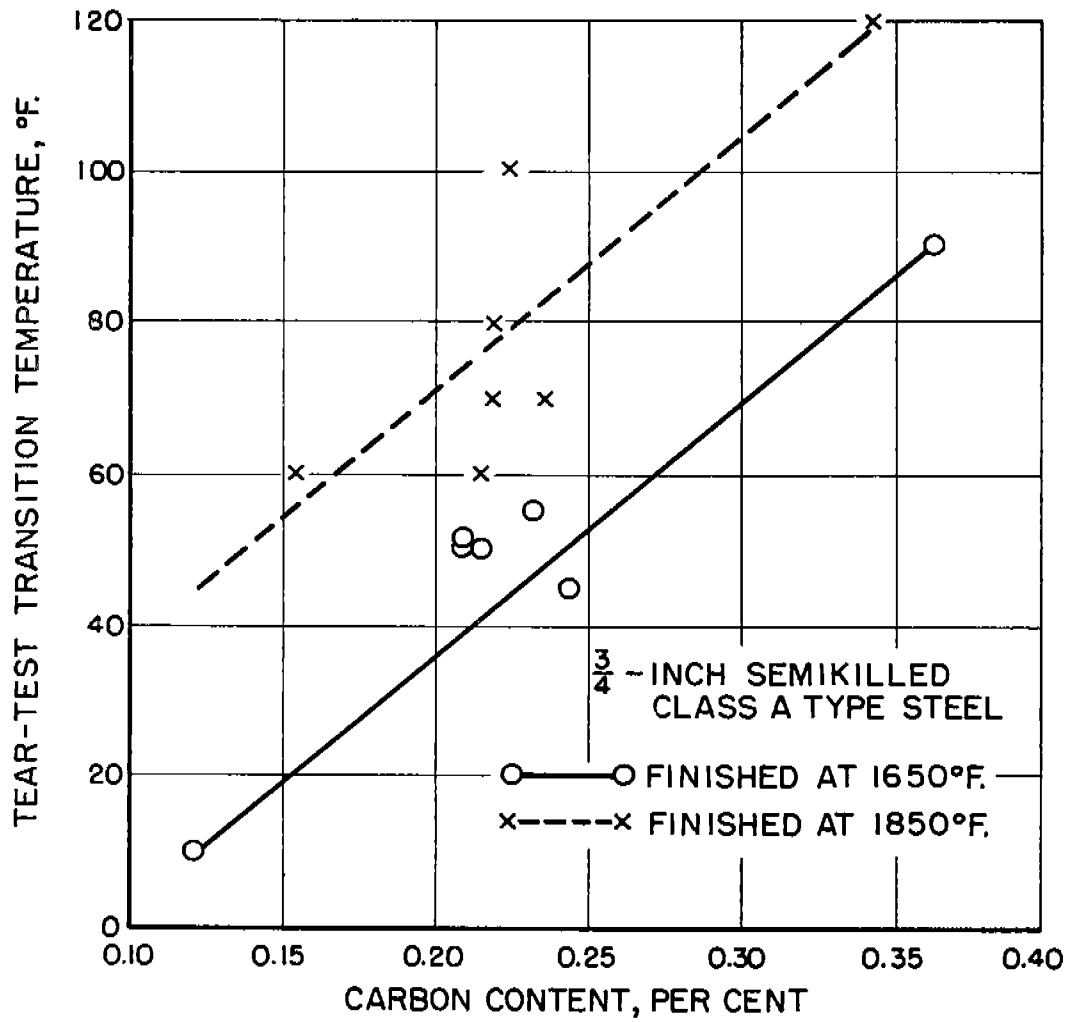

FIGURE 5. INFLUENCE OF CARBON CONTENT UPON THE TRANSITION TEMPERATURE OF CLASS A TYPE LABORATORY STEELS

finished at 1650^oF.; however, the lower finishing temperature depresses the transition temperature about 30^oF. From figure 6, it will be noted that the carbon content has a similar effect in the Class B type steels, but apparently slightly less pronounced.

Manganese

The influence of manganese content upon the transition temperature is shown in Figure 7. It is significant to note that increasing the manganese lowers the transition temperature by an appreciable extent in both the Class A and Class B type steels. This figure again illustrates the effect of finishing temperature.

The relationship between yield strength and transition temperature in the Class A type steels where the strength level was controlled by varying the carbon content is illustrated in Figure 8. These limited data indicate that increasing the yield strength 8000 psi. by raising the carbon content increasing the transition temperature about 80^oF., or roughly 10^oF. per 1000 psi.

Similar data are shown in Figure 9 for the Class A type steels in which the yield strength was varied by changing the manganese content. In this case, it will be observed that increasing the yield strength 8000 psi., by raising the manganese content, lowered the transition temperature about 40^oF.

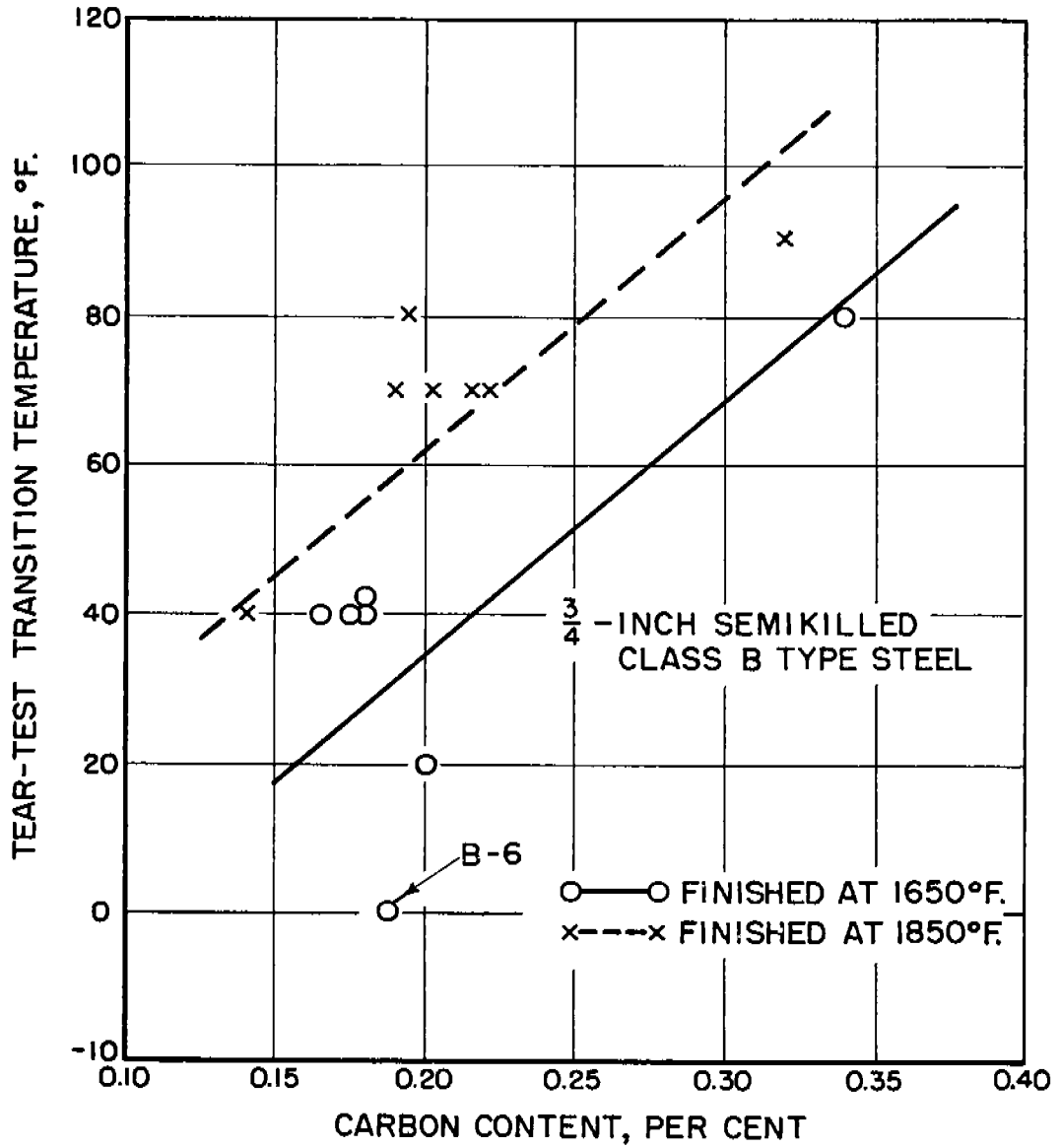

FIGURE 6. INFLUENCE OF CARBON CONTENT UPON THE TRANSITION TEMPERATURE OF CLASS B TYPE LABORATORY STEELS

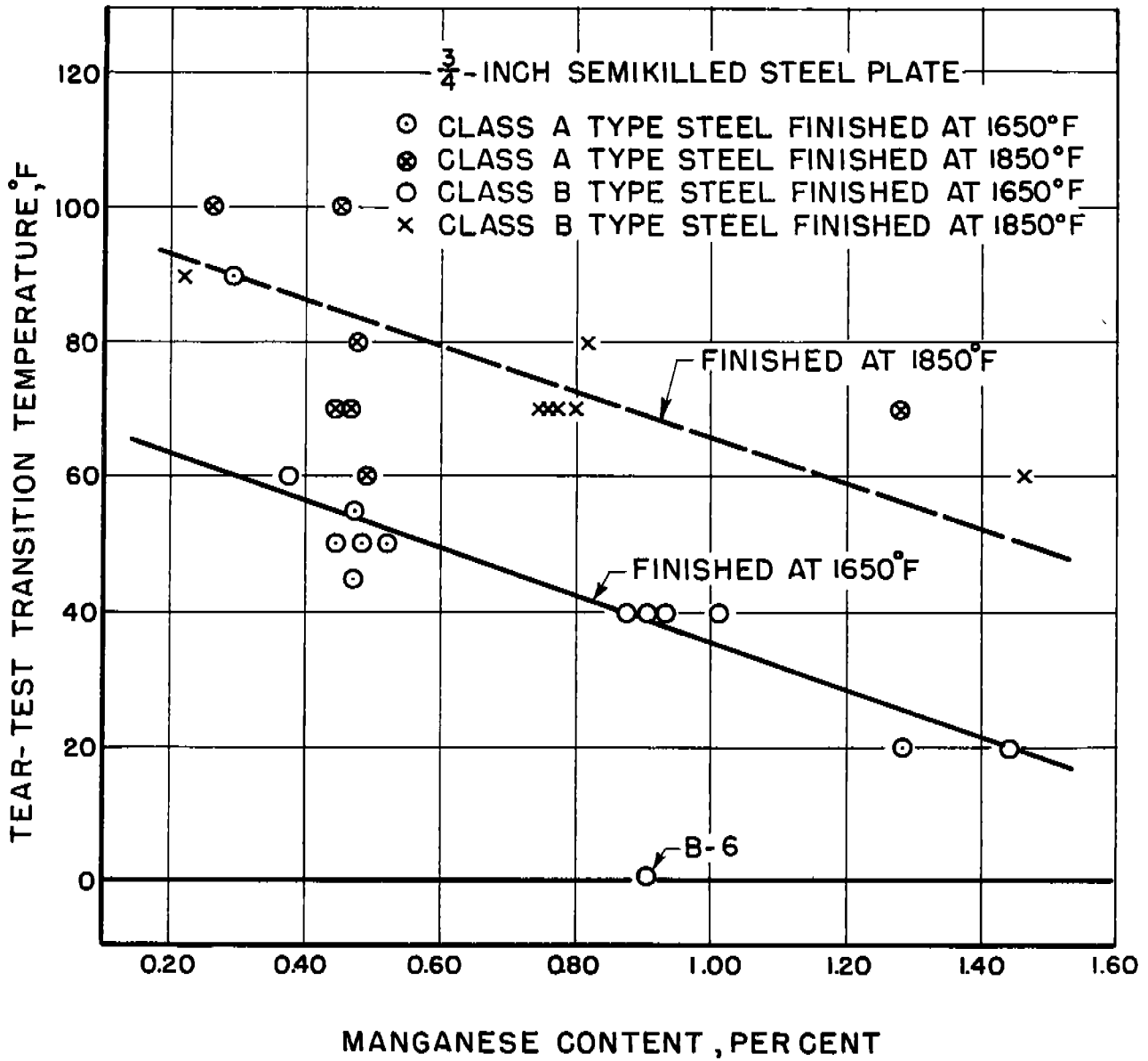

FIGURE 7. INFLUENCE OF MANGANESE CONTENT UPON THE TRANSITION TEMPERATURE OF LABORATORY STEELS

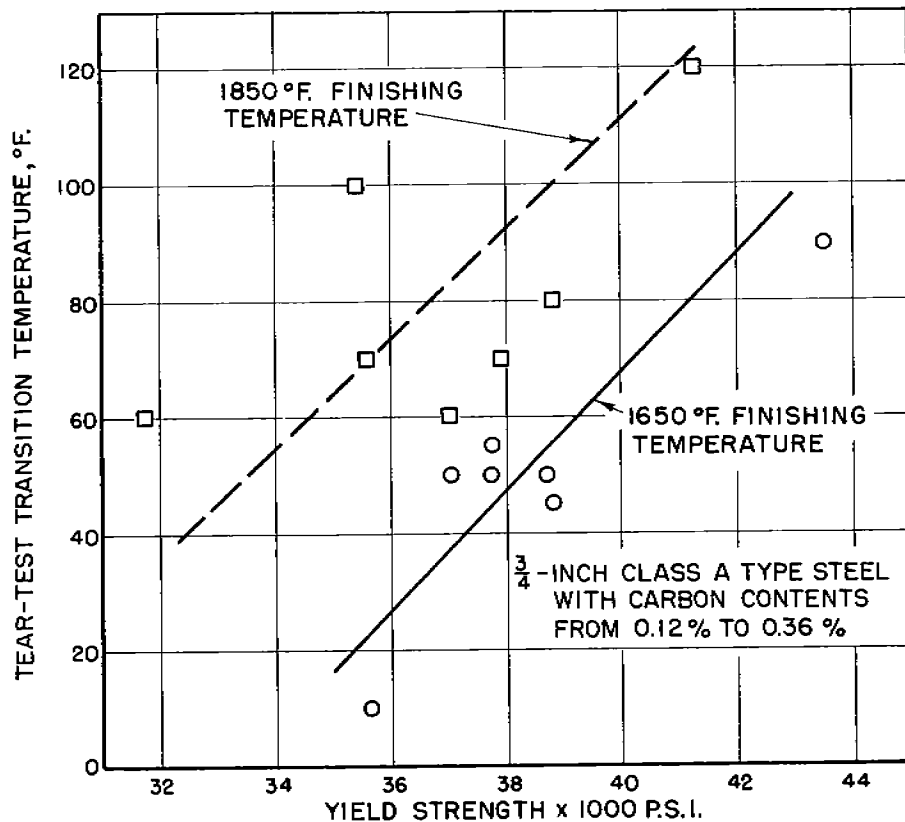

FIGURE 8. RELATIONSHIP BETWEEN YIELD STRENGTH AND TRANSITION TEMPERATURE WHEN YIELD STRENGTH WAS VARIED BY CHANGING THE CARBON CONTENT

88601

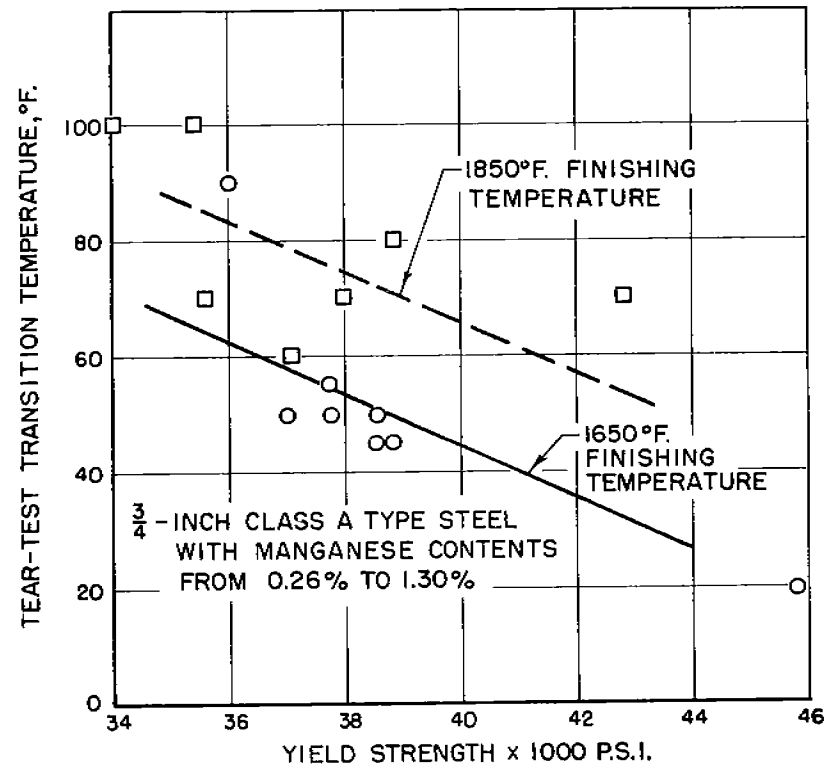

FIGURE 9. RELATIONSHIP BETWEEN YIELD STRENGTH AND TRANSITION TEMPERATURE WHEN THE YIELD STRENGTH WAS VARIED BY CHANGING THE MANGANESE CONTENT

88602

While the relationship between yield strength and transition temperature, as influenced by carbon and manganese content, is based on limited data, so that the absolute values are not too significant, these data do indicate that the most desirable yield strength to transition temperature ratio is achieved by obtaining a considerable portion of the required strength from the manganese content and reducing the carbon content to a minimum.

Silicon

It appears that silicon content has little or no effect upon the transition temperatures of Class A type steels as illustrated in Figure 10. From the data in Figure 11, it appears, however, that increased silicon content of Class B. type steels up to about 0.20 per cent lowers the transition temperature while additional silicon causes the transition temperature to increase. In the case of killed steels, Rinebolt and Harris⁽⁵⁾ report that, as the silicon content is increased above about 0.26 per cent, the transition temperature is raised. This appears to be in agreement with the results obtained from the higher silicon Class B type heats.

Phosphorus

The data in Figures 12 and 13 show that the transition temperature is very definitely raised by increasing the phosphorus

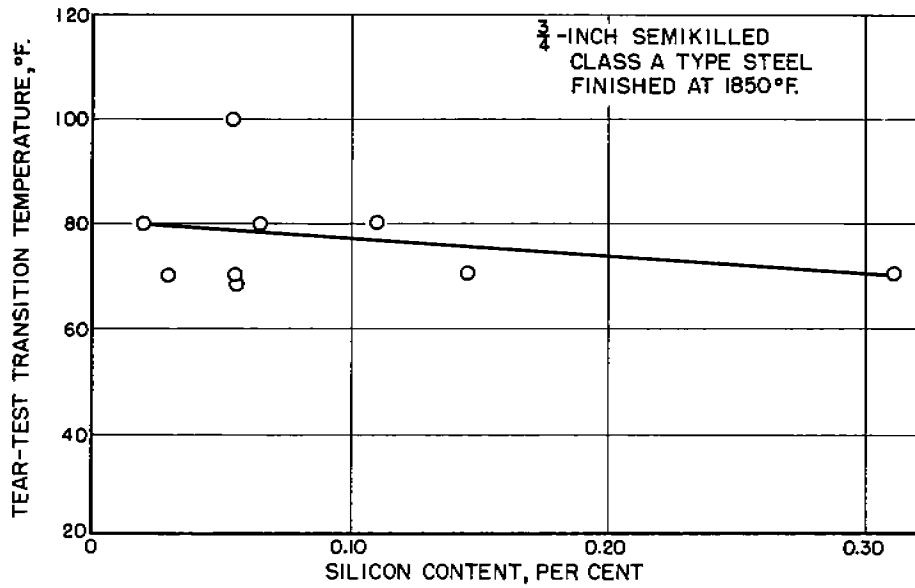

FIGURE 10. INFLUENCE OF SILICON CONTENT UPON THE TRANSITION TEMPERATURE OF CLASS A TYPE LABORATORY STEELS

88605

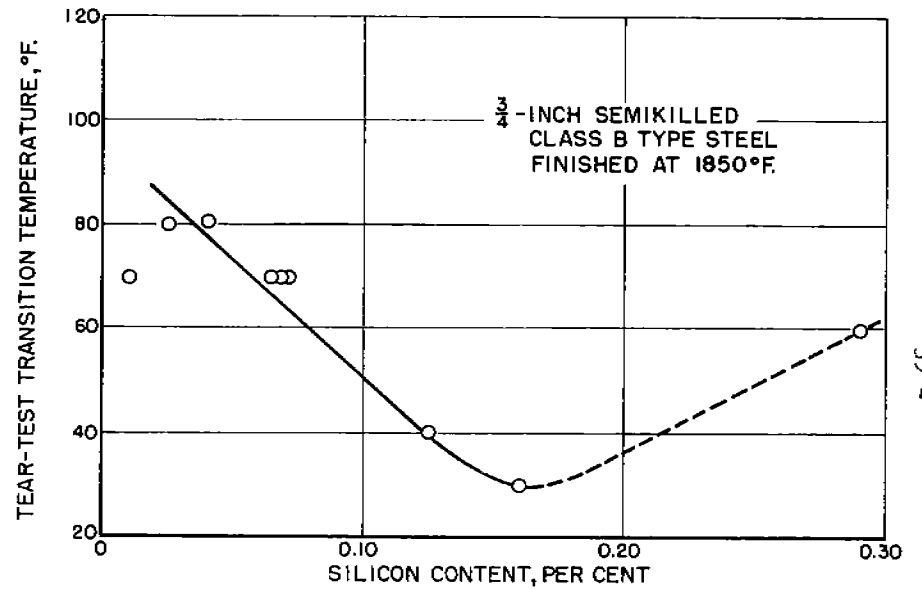

FIGURE 11. INFLUENCE OF SILICON CONTENT UPON THE TRANSITION TEMPERATURE OF CLASS B TYPE LABORATORY STEELS

88606

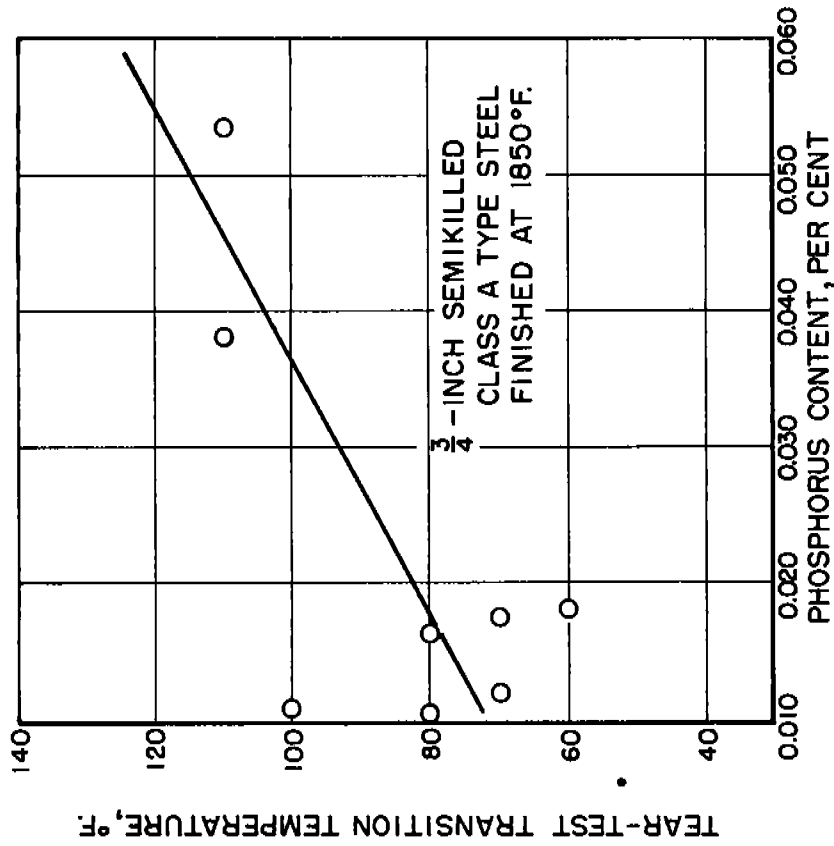

FIGURE 12. INFLUENCE OF PHOSPHORUS CONTENT UPON THE TRANSITION TEMPERATURE OF CLASS A TYPE LABORATORY STEELS

88603

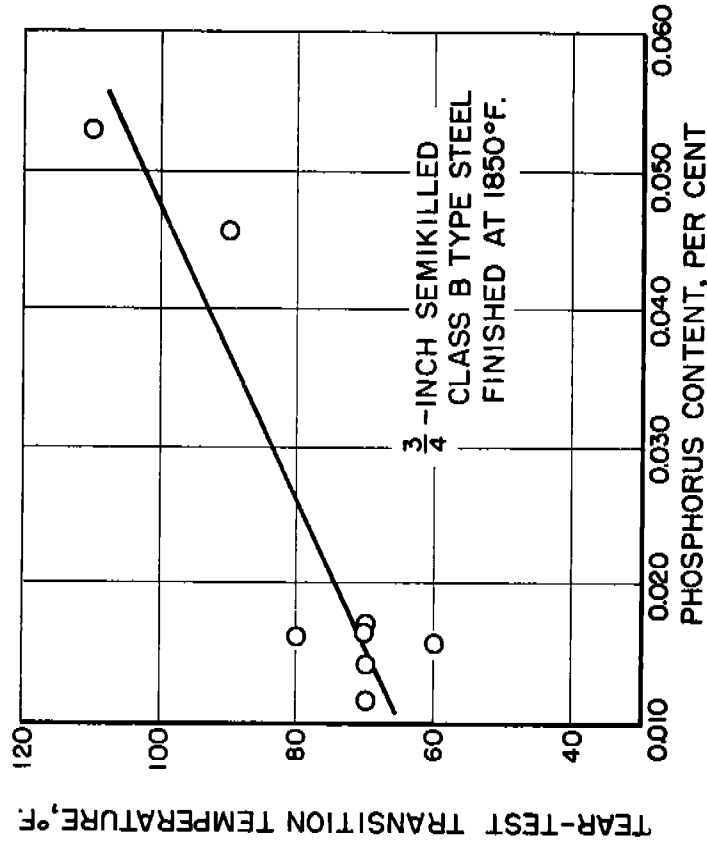

FIGURE 13. INFLUENCE OF PHOSPHORUS CONTENT UPON TRANSITION TEMPERATURE OF CLASS B TYPE LABORATORY STEELS

88604

content, the effects being similar in both classes of steel. The indications are that the range of phosphorus content that may be encountered in commercial ship plate is sufficiently broad to have perceptible effect on the transition temperature.

Sulphur

The indications are, from the limited data, that sulphur has little effect on, or may possibly lower to a slight extent, the transition temperature of Class A and Class B type steels. From these data, as illustrated in Figures 14 and 15, it appears that the range of sulphur encountered in commercial steels would have no significant influence on the transition temperature.

Vanadium

Vanadium was found to have a pronounced effect upon the transition temperature, especially with additions of more than about 0.10 per cent. This effect of vanadium is shown in Figure 16, which indicates that the addition of 0.20 per cent vanadium raised the transition temperature by about 80°F. However, the marked influence of vanadium upon the yield strength, as shown in Figure 17, must be taken into consideration when evaluating vanadium as an alloy.

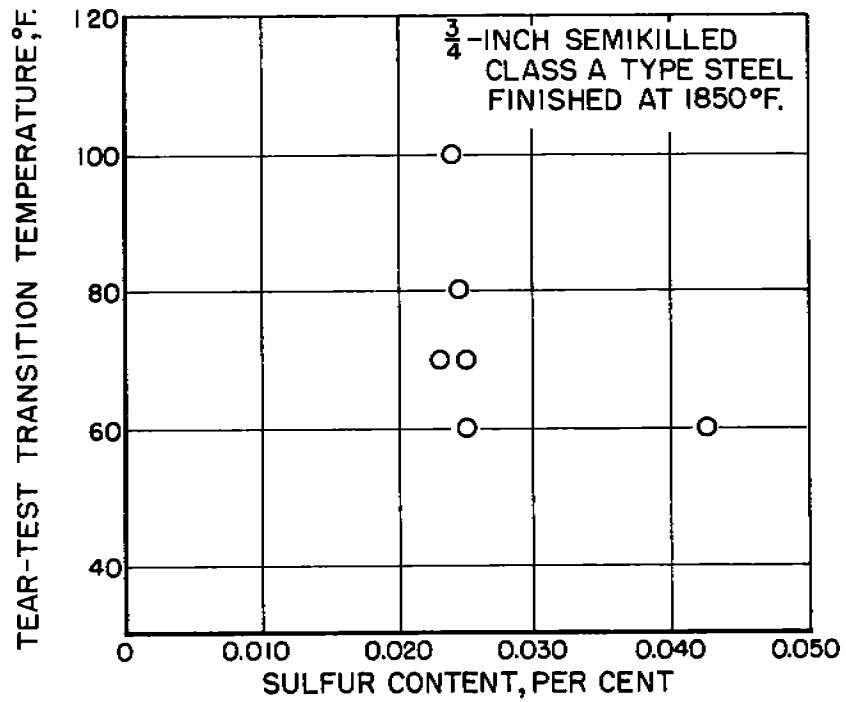

FIGURE 14. INFLUENCE OF SULFUR CONTENT UPON THE TRANSITION TEMPERATURE OF CLASS A TYPE LABORATORY STEELS

88607

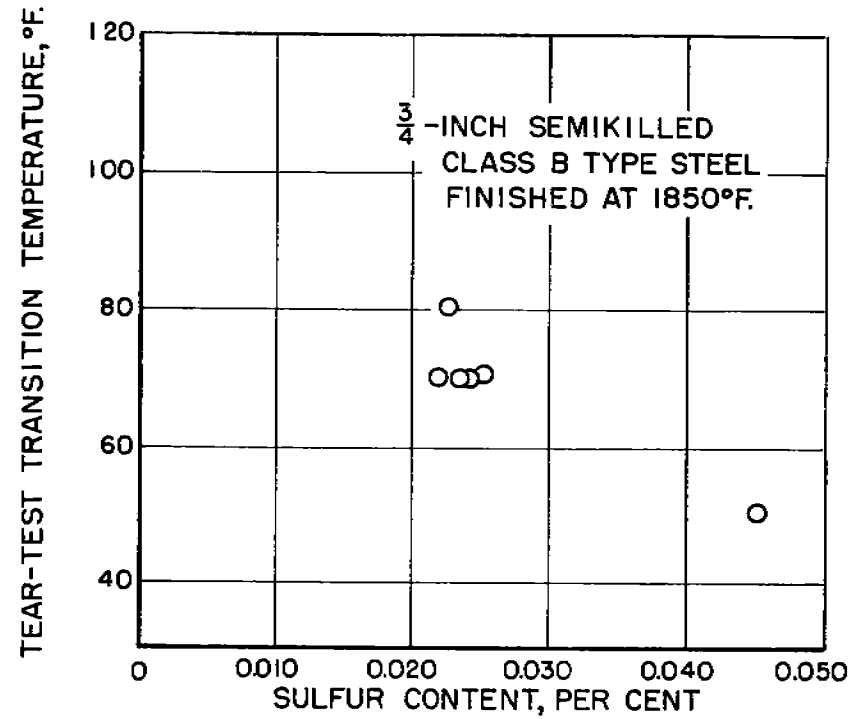

FIGURE 15. INFLUENCE OF SULFUR CONTENT UPON THE TRANSITION TEMPERATURE OF CLASS B TYPE LABORATORY STEELS

88608

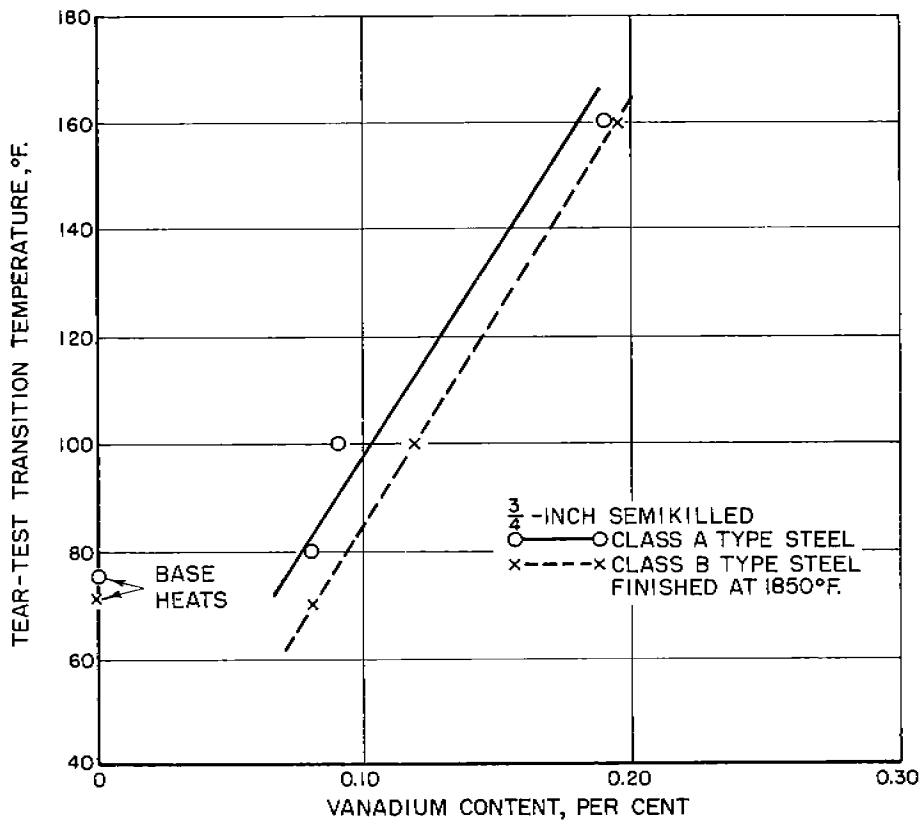

FIGURE 16. INFLUENCE OF VANADIUM CONTENT UPON THE TRANSITION TEMPERATURE OF CLASS A AND CLASS B TYPE LABORATORY STEELS

88609

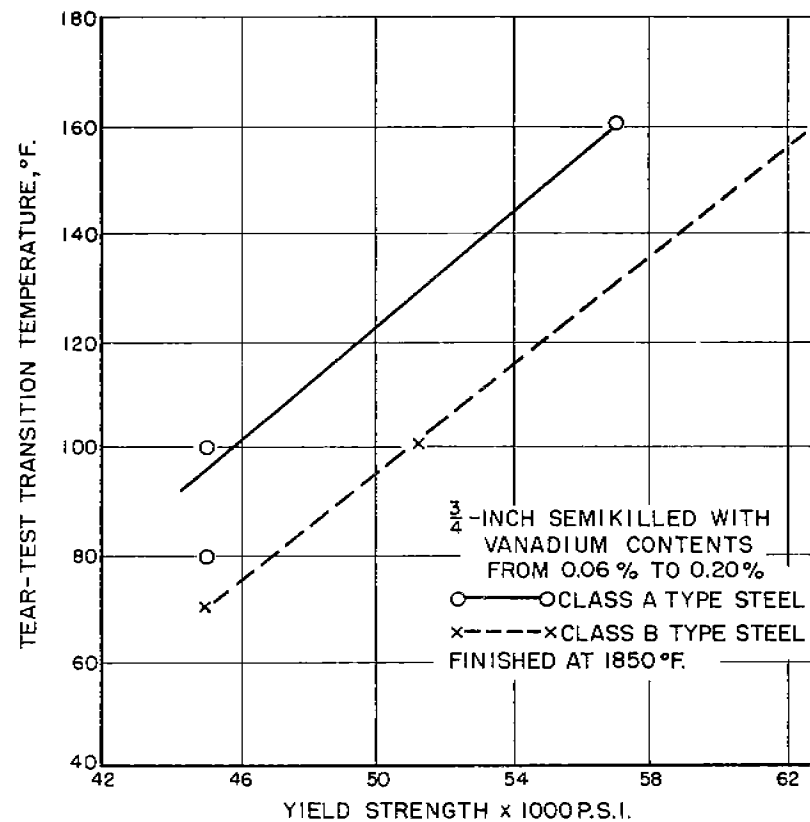

FIGURE 17. RELATIONSHIP BETWEEN YIELD STRENGTH AND TRANSITION TEMPERATURE WHEN THE YIELD STRENGTH WAS VARIED BY CHANGING THE VANADIUM CONTENT

88610

SUMMARY

The data presented in this paper show that 200-pound semi-killed laboratory heats can be made with ample reproducibility for use in studying the influence of chemical composition and deoxidation upon the transition-temperature characteristics of ABS Class A and Class B plate steels.

The transition temperature of steels of the Class A and Class B types was found to be progressively raised, and to an appreciable extent, by increasing the carbon phosphorus, and vanadium contents within the limits studied in this investigation.

Limited data indicated that increased sulphur did not raise the transition temperature but possibly lowered it. In the range in which sulphur occurs in commercial steels, it would not be expected to have a significant effect.

In order to establish definitely the effect of silicon content, more data are needed.

The transition temperature was definitely lowered by increasing the manganese content in the range covered in this investigation. The transition temperature was also lowered by decreasing the finishing temperature of the hot-rolled plate, the effect being quite pronounced.

This investigation is being continued under Contract NObs 53239, Index No. NS-011-078.

REFERENCES

- (1) Osborn, C. J., A. F. Scotchbrook, R. D. Stout, and B. G. Johnston: "Comparison of Notch Tests and Brittleness Criteria", Welding Journal, 28, No. 1, pp. 24s-34s (1949).
- (2) Kahn, N. A., and E. A. Imbembo: "Notch Sensitivity of Steel Evaluated by Tear Test", Welding Journal, 28, No. 4, pp. 153s-165s.
- (3) Kahn, N. A., and E. A. Imbembo: "A Method of Evaluating Transition from Shear to Cleavage Failure in Ship Plate and Its Correlation with Large-Scale Plate Tests", Welding Journal, 27, No. 4, pp. 169-186 (1948).
- (4) Kahn, N. A., and E. A. Imbembo: "Notch-Sensitivity of Ship Plate - Correlation of Laboratory-Scale Tests with Large-Scale Plate Tests", Special Technical Publication No. 87, ASTM (1949)
- (5) Rinebolt, J. A., and W. J. Harris, Jr.: "Effect of Alloying Elements of Notch Toughness of Pearlitic Steels", ASM Preprint No. 33, 1950.

APPENDIX

TABLE 1-A TENSILE-TEST DATA FOR CLASS A AND CLASS B
STEELS IN REPRODUCIBILITY STUDY OF LABORATORY
STEELS FINISHED AT 1650°F.

Grade of Steel	Heat No.	Specimen Number	Yield Strength psi.	Tensile Strength psi.	Elongation in 8 in., %
Class A	A-1	1	36,800	61,700	25.0
		2	37,300	61,500	18.0
Class A	A-2	1	38,700	60,500	31.5
		2	38,900	60,700	33.5
Class A	A-3	1	37,200	60,100	31.0
		2	38,200	58,700	29.5
Class A	A-4	1	37,300	58,900	33.0
		2	38,000	58,900	34.0
Class A	A-5	1	38,700	59,200	29.5
		2	38,500	59,000	28.5
Class B	B-2	1	35,900	57,800	32.5
		2	35,500	58,000	30.0
Class B	B-3	1	35,900	61,500	31.0
		2	36,500	61,500	31.0
Class B	B-4	1	38,100	59,600	31.0
		2	38,500	60,200	30.5
Class B	B-5	1	41,700	63,300	30.5
		2	40,100	64,500	30.5
Class B	B-6	1	43,000	63,200	33.0
		2	42,600	63,200	32.0

TABLE 1-B. NAVY TEAR-TEST DATA FOR CLASS A AND CLASS B
STEELS IN REPRODUCIBILITY STUDY OF LABORATORY
STEELS FINISHED AT 1650° F.

Heat Number	Specimen Number	Testing Temperature, °F.	Maximum Load Pounds	Energy to Start Fracture, Ft.-Lbs.	Energy to Propagate Fracture, Ft. -Lbs.	% Shear in Fracture
A-1	A1T1	30	38,600	850	42	5
	A1G1	30	39,000	900	67	10
	A1F1	30	40,050	907	58	10
	A1O1	30	39,650	933	58	10
	A1P1	40	39,450	833	158	5
	A1N2	40	39,450	933	557	75
	A152	40	38,500	808	158	5
	A1R2	40	37,850	925	625	100
	A1P2	50	38,150	807	649	85
	A1B1	50	39,150	890	25	5
	A1U1	50	37,550	807	616	100
	A1B2	50	38,100	774	633	90
	A1E2	60	40,550	1060	750	100
	A1Q1	60	39,550	960	592	90
	A1H1	60	37,400	841	1180	100
	A1O1	60	39,450	892	616	85
	A1R1	Room	37,250	758	658	100
	A1A1	Room	38,900	900	816	100
	A1Q2	Room	38,200	865	885	100
	A1A2	Room	38,400	824	807	100
A-2	A2T2	30	39,000	850	58	5
	A2C1	30	39,300	850	17	5
	A2F2	30	39,650	925	25	5
	A2H1	30	39,050	875	17	5
	A2H2	40	38,100	825	92	10
	A2J2	40	37,750	800	657	100
	A2C2	40	38,400	816	108	5
	A2B1	40	37,950	800	75	5
	A2J1	50	38,100	950	985	100
	A2K1	50	39,250	908	993	100
	A2B2	50	36,650	741	658	100
	A2K2	50	37,350	691	708	100

TABLE 1-B (Continued)

HEAT NUMBER	SPECIMEN NUMBER	TESTING TEMPERATURE, °F.	MAXIMUM LOAD POUNDS	ENERGY TO START FRACTURE, FT. -LBS.	ENERGY TO PROPAGATE FRACTURE, FT. -LBS.	% SHEAR IN FRACTURE
	A2B1	Room	37,400	750	633	100
	A2U2	Room	37,450	775	650	100
	A2N2	Room	37,150	783	683	100
	A2D2	Room	38,050	808	675	100
A-3	A3B1	30	39,100	800	17	2
	A3H1	30	38,150	807	33	5
	A3F2	30	38,600	807	100	5
	A3U2	30	37,450	750	17	2
	A3C2	40	38,750	666	58	5
	A3G1	40	38,050	757	58	5
	A3D1	40	36,550	716	25	5
	A3K2	40	36,850	749	92	10
	A3G1	50	36,400	667	92	5
	A3H2	50	36,650	725	650	100
	A3F1	50	35,750	700	408	55
	A3D2	50	38,050	816	75	5
	A3E2	60	37,350	808	558	85
	A3K1	60	37,250	816	625	100
	A3T2	60	37,400	825	550	100
	A3V2	60	35,750	717	633	100
	A3V1	Room	35,550	658	667	100
	A3S1	Room	36,050	708	667	100
	A3R2	Room	36,000	708	733	100
	A3R1	Room	36,450	700	667	100
A-4	A4U2	20	37,350	816	67	10
	A4H2	20	38,400	842	67	10
	A4E1	20	39,300	925	67	5
	A4V2	20	38,100	875	150	10
	A4A1	30	38,900	824	17	5
	A4N1	30	36,650	741	641	100
	A4L2	30	39,150	800	42	5
	A4G2	30	38,100	841	700	100

TABLE 1-B (Continued)

HEAT NUMBER	SPECIMEN NUMBER	TESTING TEMPERATURE °F.	MAXIMUM LOAD POUNDS	ENERGY TO START FRACTURE, FT. -LBS.	ENERGY TO PROPAGATE FRACTURE, FT. -LBS.	% SHEAR IN FRACTURE	
A-4	A4T2	40	36,600	966	666	100	
	A4K1	40	36,250	742	350	40	
	A4C1	40	38,700	908	75	10	
	A4J1	40	37,850	825	608	100	
	A4H1	50	36,550	757	607	100	
	A4K2	50	37,650	815	616	100	
	A4T1	50	35,850	757	890	100	
	A4A2	50	38,000	882	42	5	
	A4M2	60	37,650	833	615	100	
	A4U1	60	35,500	675	708	100	
	A4G1	60	37,600	800	700	100	
	A4D1	60	37,400	866	625	100	
	A4J2	Room	36,900	775	600	100	
	A4V1	Room	34,950	700	657	100	
	A4E2	Room	36,250	750	616	100	
	A4M1	Room	36,600	707	650	100	
	A-5	A5T1	20	39,250	925	42	10
		A5K2	20	39,100	850	67	5
		A5V1	20	38,500	925	75	5
A5L2		20	39,750	891	67	5	
A5H1		30	40,550	1024	17	5	
A5B2		30	35,250	683	325	30	
A5J1		30	39,700	934	42	5	
A5L1		30	38,700	875	42	5	
A5P1		40	37,950	907	75	5	
A5K2		40	36,350	766	600	100	
A5V1		40	37,150	808	642	100	
A5H2		40	38,200	958	642	90	
A5Q2		50	36,500	857	33	10	
A5P2		50	36,900	865	725	100	
A5K2		50	36,750	807	641	100	
A5C1		50	37,450	947	42	5	

TABLE 1-B. (Continued)

HEAT NUMBER	SPECIMEN NUMBER	TESTING TEMPERATURE °F.	MAXIMUM LOAD POUNDS	ENERGY TO START FRACTURE, FT. -LBS.	ENERGY TO PROPAGATE FRACTURE, FT. -LBS.	% SHEAR in FRACTURE
A-5	A5U2	60	36,550	825	650	100
	A5R2	60	37,150	860	642	100
	A5B1	60	37,450	900	750	100
	A5V2	60	37,400	925	566	85
B-2	B2M1	20	40,300	1042	67	5
	B2T1	20	39,500	958	17	5
	B2E2	20	41,600	1058	67	5
	B2P1	20	39,850	1016	33	5
	B2N2	30	40,100	1041	92	5
	B2F2	30	40,700	1082	591	90
	B2N2	30	39,100	925	25	5
	B2N1	30	49,350	1200	100	10
	B2R1	40	38,600	1016	100	5
	B2S1	40	37,050	925	700	100
	B2Q2	40	39,000	1075	83	5
	B2U1	40	37,600	924	717	100
	B2V2	50	36,550	882	691	100
	B2F1	50	38,000	948	725	95
	B2Q1	50	37,350	900	674	100
	B2V1	50	38,250	907	700	100
	B2S2	Room	37,550	942	692	100
	B2P2	Room	37,000	908	692	100
	B2M2	Room	37,450	933	683	100
	B2E1	Room	37,500	875	667	95
B-3	B3S2	10	40,050	833	75	5
	B3Q2	10	41,150	1050	25	5
	B3E2	10	41,300	1010	33	5
	B3S1	10	40,950	1025	58	5
	B3B1	20	42,800	1175	108	5
	B3K2	20	41,350	1000	58	10
	B3R2	20	40,800	957	25	5
	B3Q1	20	41,800	1000	758	100

TABLE 1-B . (CONTINUED)

HEAT NUMBER	SPECIMEN NUMBER	TESTING TEMPERATURE, °F.	MAXIMUM LOAD, POUNDS	ENERGY TO START FRACTURE, FT.-LBS.	ENERGY TO PROPAGATE FRACTURE, FT. -LBS.	% SHEAR IN FRACTURE	
B-3	B3A1	30	42,850	1217	841	90	
	B3D2	30	42,100	1082	575	85	
	B3W2	30	41,750	983	741	100	
	B3U1	30	40,750	950	659	100	
	B3A2	40	40,950	1050	583	70	
	B3E1	40	40,450	1026	100	5	
	B3U2	40	39,550	933	683	100	
	B3T2	40	39,600	965	200	25	
	B3K1	50	39,400	875	750	100	
	B3T1	50	39,700	957	682	100	
	B3C2	50	41,000	1058	716	100	
	B3V1	50	39,350	932	649	100	
	B3P1	Room	38,800	875	642	100	
	B3D1	Room	40,000	1008	707	100	
	B3E2	Room	38,900	975	807	100	
	B3R1	Room	39,700	1032	625	100	
	B-4	B4H2	10	40,900	1040	75	5
		B4J2	10	40,750	1000	42	5
		B4B1	10	40,800	1140	42	5
		B4B2	10	42,700	1115	33	5
B4Q1		20	38,600	875	133	10	
B4H1		20	42,450	1075	100	10	
B4K2		20	41,200	1050	25	5	
B4G1		20	41,700	1058	717	100	
B4D2		30	40,850	1232	691	90	
B4A2		30	41,100	1025	201	20	
B4S2		30	40,000	908	815	100	
B4J1		30	41,450	1015	582	70	
B4Q2		40	39,000	925	642	90	
B4C1		40	40,100	992	75	5	
B4C2		40	40,300	983	75	10	
B4E2		40	40,450	1025	650	100	

TABLE 1-B. (CONTINUED)

HEAT NUMBER	SPECIMEN NUMBER	TESTING TEMPERATURE °F.	MAXIMUM LOAD, POUNDS	ENERGY TO START FRACTURE, FT. -LBS.	ENERGY TO PROPAGATE FRACTURE, FT. -LBS.	% SHEAR IN FRACTURE
	B4E1	50	39,650	1000	732	100
	B4F1	50	39,950	1000	666	100
	B4T1	50	38,050	925	683	100
	B4F2	50	39,600	1032	749	100
B-5	B5C2	0	44,850	1075	92	5
	B5P2	0	45,100	1140	92	5
	B5T1	0	44,800	1090	850	100
	B5Q1	10	45,100	1124	58	5
	B5U2	10	43,300	1000	33	10
	B5P1	10	45,100	1065	50	5
	B5S1	10	44,250	1065	766	100
	B5S2	20	44,400	1058	92	15
	B5V1	20	45,500	1150	675	95
	B5F2	20	45,450	1140	575	80
	B5B2	20	45,650	1158	175	10
	B5G2	30	44,600	1000	125	5
	B5Q2	30	44,300	1158	724	100
	B5E1	30	45,700	1072	867	100
	B5B1	30	44,750	1099	833	100
	B5D1	40	43,950	1117	508	70
	B5E2	40	44,350	1142	25	5
	B5D2	40	44,100	1142	75	10
	B5F1	40	44,400	1158	1400	100
	B5R2	50	41,300	1025	642	100
	B5R1	50	40,950	892	742	100
	B5G1	50	42,200	992	675	100
	B5V2	50	40,550	891	583	100
	B5N1	Room	41,750	925	883	100
	B5G1	Room	42,650	1091	742	100
	B5U1	Room	41,800	891	767	100
	B5N2	Room	41,600	883	867	100

TABLE 1-B. (CONTINUED)

HEAT NUMBER	SPECIMEN NUMBER	TESTING TEMPERATURE °F.	MAXIMUM LOAD, POUNDS	ENERGY TO START FRACTURE, FT. -LBS.	ENERGY TO PROPAGATE FRACTURE, FT. -LBS.	% SHEAR IN FRACTURE
B-6	B6E2	-10	44,750	990	75	5
	B6D2	0	44,700	1017	1334	100
	B6V1	0	42,050	916	742	100
	B6U1	0	42,000	841	142	5
	B6D1	10	44,400	1060	666	100
	B6C2	10	44,250	966	716	95
	B6X1	10	43,100	1040	733	100
	B6W1	10	42,500	925	658	100
	B6V2	20	41,550	808	684	100
	B6S1	20	42,550	1000	734	100
	B6K1	20	42,900	942	725	95
	B6F2	20	44,650	942	766	100
	B6U2	30	40,550	833	867	100
	B6X2	30	40,650	775	667	100
	B6L1	30	44,450	1050	966	100
	B6C1	30	44,300	1040	807	100
	B6E1	40	42,250	933	766	100
	B6K2	40	42,150	907	733	100
	B6F1	40	43,250	983	716	100
	B6H1	40	42,100	941	692	100
	B6G1	50	41,250	924	800	100
	B6W2	50	39,250	1025	633	100
	B6H2	50	41,900	933	890	100
	B6G2	50	42,500	990	783	100
	B6S2	Room	39,650	817	683	100
	B6L2	Room	39,500	833	732	100
	B6T1	Room	40,100	883	683	100
	B6T2	Room	40,550	942	633	100

TABLE 1-C CHARPY IMPACT DATA FOR CLASS A AND CLASS B STEELS IN REPRODUCIBILITY STUDY OF LABORATORY STEELS FINISHED AT 1650 F.

Heat Number	Testing Temperature, F.	Charpy Impact Strength, Ft.-Lbs.			
		1st. Test	2nd. Test	3rd. Test	4th. Test
A1	80	34	35	34	34
	40	29	25	28	28
	20	24	27	28	27
	0	5	5	6	24
	-20	4	19	5	21
	-40	2	2	5	3
A2	80	28	38	32	32
	40	27	27	27	32
	20	27	25	24	21
	0	23	17	22	25
	-20	18	20	24	21
	-40	5	17	15	14
A3	80	30	27	28	28
	40	29	27	27	25
	20	23	21	21	21
	0	4	5	5	23
	-20	4	4	17	3
	-40	5	2	2	2
A4	80	31	33	30	31
	40	28	26	24	25
	20	24	23	23	25
	0	20	21	16	24
	-20	5	4	19	3
	-40	2	4	3	3
A5	80	35	34	33	33
	40	25	28	30	30
	20	11	25	27	26
	0	7	8	21	6
	-20	19	18	19	4
	-40	3	3	3	3
B2	80	38	46	40	42
	40	30	36	36	37
	20	27	34	33	33
	-20	16	30	7	17
	-40	3	5	4	3
	-60	2	2	2	2

Table 1-C. (Continued)

Heat Number	Testing Temperature, °F.	Charpy Impact Strength, Ft. -Lbs.			
		1st Test	2nd Test	3rd Test	4th Test
B-3	80	42	39	39	40
	40	35	38	36	42
	20	33	35	30	29
	-20	25	27	31	28
	-40	3	18	15	25
	-60	2	2	2	2
B-4	80	40	42	35	37
	40	35	35	37	35
	20	40	33	32	29
	-20	6	25	9	29
	-40	5	21	5	26
	-60	2	3	3	2
B-5	80	48	38	42	43
	40	43	42	37	38
	20	34	33	40	35
	-20	27	30	33	28
	-40	31	25	32	26
	-60	3	3	3	3
B-6	80	39	40	42	40
	40	38	35	40	34
	20	38	35	33	32
	-20	33	29	29	33
	-40	25	23	25	4
	-60	4	2	3	20

TABLE 2-B . TEAR-TEST DATA FOR CLASS A AND CLASS B STEELS
MADE TO STUDY THE INFLUENCE OF FINISHING
TEMPERATURE

Heat No.	Specimen No.	Testing Temp., °F.	Maximum load Lbs.	Energy to Start Fracture Ft. -Lbs.	Energy to Propagate Fracture, Ft. -Lbs.	% Shear in Fracture
A-6424 (Class A finished at 1650°F.)	A24C2	40	36,850	1025	150	5
	A24A2	50	36,250	859	133	5
	A24C1	60	36,700	907	675	100
	A24B1	60	36,350	893	859	100
	A24D2	60	37,400	975	641	100
	A24A1	60	37,400	975	659	100
A-6424 (Class A finished at 1750°F.)	B24C2	50	36,500	933	125	5
	B24A2	60	37,200	1050	608	100
	B24D2	60	36,350	983	75	5
	B24B1	70	35,450	916	641	100
	B24D1	70	36,350	1008	616	95
	B24C1	70	35,800	983	741	95
	B24B2	70	36,250	967	800	100
A-6424 (Class A finished at 1850°F.)	C24A2	50	35,700	916	108	5
	C24C2	60	34,900	858	117	5
	C24D2	70	35,750	893	125	5
	C34C1	80	35,900	907	117	5
	C24A1	90	35,850	1008	750	100
	C24B1	90	35,500	1033	625	100
	C24B2	90	35,000	793	233	25
	C24D1	90	35,150	807	708	100

TABLE 2-A. TENSILE-TEST DATA FOR CLASS A AND CLASS B
STEELS MADE TO STUDY THE INFLUENCE OF
FINISHING TEMPERATURE

GRADE OF STEEL	HEAT NO.	SPECIMEN NO.	FINISHING TEMP., °F.	YIELD STRENGTH psi.		TENSILE STRENGTH psi.	ELONGATION IN 8 IN. %
				Upper	Lower		
Class A	A-6424	1	1650	38,000	34,800	57,200	31.5
		2		37,900	35,000		57,200
Class A	A-6424	1	1750	34,300	32,800	57,600	31.0
		2		35,000	33,100		57,600
Class A	A-6424	1	1850	34,300	33,300	58,800	29.0
		2		33,700	32,300		57,700
Class B	A-6365	1	1650	40,000	39,600	64,000	29.5
		2		40,300	39,700		64,000
Class B	A-6365	1	1750	39,000	37,300	63,700	32.5
		2		38,300	37,700		63,700
Class B	A-6365	1	1850	38,500	35,900	63,500	32.0
		2		37,800	36,700		64,200

TABLE 2-B. (Continued)

HEAT NO.	SPECIMEN NO.	TESTING TEMP., °F.	MAXIMUM LOAD, LBS.	ENERGY TO START FRACTURE, FT. -LBS.	ENERGY TO PROPAGATE FRACTURE, FT. -LBS.	% SHEAR in FRACTURE
A-6365 (Class B finished at 1650° F.)	A65D2	10	42,100	1075	125	5
	A65B2	20	42,000	1209	825	100
	A65D1	20	41,850	1090	757	100
	A65C1	20	41,600	1159	566	100
	A65A2	20	42,650	1124	791	100
	A65A1	30	41,400	1150	708	100
	A65B1	40	40,450	1108	692	100
A6365 (Class B finished at 1750° F.)	B65B1	20	43,100	1181	142	5
	B65C1	30	41,650	1075	791	100
	B65D1	30	41,450	1100	833	100
	B65B2	30	41,800	1033	816	100
	B65D2	30	41,800	1108	916	100
A-6365 (Class B finished at 1850° F.)	C65C1	20	40,700	1033	158	5
	C65E2	30	40,800	1108	392	50
	C65A2	30	40,200	1158	185	15
	C65A1	40	39,850	1140	408	45
	C65E1	40	40,550	1075	142	5
	C65C2	50	40,250	1008	708	95
	C65B1	50	39,450	1018	608	90
	C65D1	50	40,250	1008	633	95
C65D2	50	40,150	1033	591	90	

TABLE 3-A. TENSILE-TEST DATA FOR CLASS A AND CLASS B STEELS MADE TO STUDY THE REPRODUCIBILITY OF LABORATORY STEELS FINISHED AT 1850 F.

GRADE OF STEEL	HEAT NUMBER	SPECIMEN NUMBER	YIELD STRENGTH		TENSILE STRENGTH, psi	ELONGATION IN 8 IN., %
			UPPER	LOWER		
Class A	A6555	1	37,500	36,100	62,800	28.0
		2	40,200	36,000	62,600	27.5
Class A	A6556	1	37,300	34,800	61,500	32.0
		2	38,600	35,200	61,700	30.0
Class A	A6587	1	35,300	34,200	61,200	30.0
		2	35,500	34,700	62,100	29.5
Class A	A6650	1	35,300	34,100	60,200	27.0
		2	35,900	34,400	60,900	29.5
Class A	A6705	1	36,700	35,800	62,500	22.0
		2	37,400	36,000	63,500	27.0
Class B	A6557	1	36,100	35,300	61,600	30.0
		2	36,300	35,700	61,800	30.0
Class B	A6584	1	36,400	35,500	61,900	31.0
		2	36,300	35,300	62,000	30.0
Class B	A6588	1	35,400	34,800	62,100	28.5
		2	35,700	35,000	62,600	28.0
Class B	A6641	1	36,100	34,800	62,900	28.5
		2	37,000	35,900	62,800	19.5
Class B	A6651	1	36,200	35,700	62,000	28.0
		2	38,200	35,700	62,600	29.5

TABLE 3-B. NAVY TEAR-TEST DATA FOR CLASS A AND CLASS B STEELS
MADE TO STUDY THE REPRODUCIBILITY OF LABORATORY STEELS
FINISHED AT 1850 F.

Heat Number	Specimen Number	Testing Temperature, °F.	Maximum Load Pounds	Energy to Start Fracture Ft. -Lbs.	Energy to Propagate Fracture Ft. -Lbs.	% Shear in Fracture	
A6555	G1	50	37,700	775	33	3	
	E1	60	38,950	750	186	15	
	K1	70	36,500	591	616	100	
	M2	70	38,500	716	75	10	
	F1	80	38,500	908	725	100	
	L1	80	37,600	716	633	100	
	K2	80	38,500	783	117	10	
	L2	90	36,900	725	660	95	
	E2	90	38,000	875	892	100	
	F2	90	38,150	858	725	100	
	G2	90	37,800	800	708	100	
	A6556	E1	50	38,700	865	50	5
		G2	60	38,400	783	241	15
		M2	70	37,000	675	583	100
H2		70	38,500	583	42	10	
E2		80	38,500	808	542	100	
F2		80	38,250	757	516	95	
L1		80	38,200	733	815	100	
H1		80	38,250	850	875	100	
A6587	S1	50	36,450	725	42	3	
	R2	60	36,900	833	583	90	
	P2	60	37,800	883	117	5	
	M1	70	37,200	858	58	5	
	Q2	80	37,300	800	592	100	
	S2	80	35,700	733	133	10	
	R1	80	34,900	558	692	100	
	N1	90	35,950	784	670	100	
Q1	90	35,950	733	167	10		

TABLE 3-B. (Continued)

HEAT NUMBER	SPECIMEN NUMBER	TESTING TEMPERATURE °F.	MAXIMUM LOAD, POUNDS	ENERGY TO START FRACTURE, FT. #LBS.	ENERGY TO PROPAGATE FRACTURE, FT. -LBS.	% SHEAR IN FRACTURE
A6587	P1	100	35,050	625	650	100
	M2	100	35,300	658	633	100
	N2	100	35,600	700	133	15
	#1	110	35,400	725	717	100
	#2	110	35,150	675	650	100
	#3	110	35,400	683	658	100
	#4	110	34,750	692	683	100
A6650	N1	70	37,550	917	133	5
	Q2	80	35,800	858	592	100
	S1	80	37,200	842	750	100
	M2	80	36,600	767	575	100
	P1	80	36,550	800	650	100
A6705	P2	60	36,100	817	66	5
	L1	70	35,600	783	616	100
	R1	70	37,000	817	600	100
	Q2	70	37,000	750	733	100
	M2	70	36,000	700	383	100
A6557	F1	50	40,400	992	108	5
	K1	60	41,050	975	716	100
	G1	60	38,700	866	133	10
	S1	70	40,300	960	725	100
	J1	70	40,400	875	683	100
	H1	70	40,600	900	125	15
	F2	80	40,350	1073	707	100
	H2	80	39,250	892	742	100
	G2	80	40,750	1060	1050	100
	J2	80	40,650	815	1124	100
	A6584	M2	50	39,550	917	792
P2		50	40,550	950	100	3

TABLE 3-B. (CONTINUED)

HEAT NUMBER	SPECIMEN NUMBER	TESTING TEMPERATURE, °F.	MAXIMUM LOAD POUNDS	ENERGY TO START FRACTURE, FT. -LBS.	ENERGY TO PROPAGATE FRACTURE, FT. -LBS.	% SHEAR IN FRACTURE
A6651	M1	60	39,550	833	616	100
	P2	60	38,700	892	725	95
	R1	60	38,300	842	158	5
	S2	70	38,500	858	125	10
	N1	80	38,200	751	807	100
	Q2	80	38,700	891	757	100
	R2	80	37,700	867	741	100
	N2	80	39,100	992	600	100

TABLE 4-B. NAVY TEAR-TEST DATA FOR CLASS A AND CLASS B STEELS MADE TO STUDY THE INFLUENCE OF CARBON AND MANGANESE. FINISHING TEMPERATURE - 1650°F.

Heat No.	Specimen No.	Testing Temp., °F.	Maximum Load, Lbs.	Energy to Start Fracture, Ft. - Lbs	Energy to Propagate Fracture, Ft. -Lbs.	% Shear in Fracture
(Carbon Series)						
A6293	C1	0	39,800	1540	83	10
	S1	10	38,200	1308	5	5
	H2	10	39,000	566	67	5
	B1	20	38,650	1408	883	100
	A1	20	35,450	1040	1010	100
	T1	20	38,500	1260	792	100
	C2	20	39,350	1431	2400	100
	V1	40	36,850	1125	900	100
	G1	40	38,450	1375	1225	100
	S2	40	37,250	1230	790	100
	G2	40	38,250	1275	840	90
	V2	60	36,850	1190	915	100
	B2	60	37,350	1420	730	100
	T2	60	36,850	1240	790	100
	D2	60	39,050	1465	915	100
	U1	80	36,700	1210	800	100
	H1	80	37,000	1218	815	100
	D1	80	37,950	1360	860	100
	A2	80	33,000	940	833	100
A6294	E2	80	40,200	633	192	5
	F2	80	40,700	658	175	15
	R1	80	40,700	691	158	5
	A2	80	40,750	691	125	15
	D1	90	39,050	633	33	10
	U2	90	39,450	675	108	20

TABLE 3-B (Continued)

HEAT NUMBER	SPECIMEN NUMBER	TESTING TEMPERATURE, °F.	MAXIMUM LOAD, POUNDS	ENERGY TO START FRACTURE FT. - LBS.	ENERGY TO PROPAGATE FRACTURE, FT. - LBS.	% SHEAR IN FRACTURE	
A6584	P1	60	39,600	933	767	100	
	M1	60	40,300	975	67	5	
	R1	60	40,100	1042	800	100	
	S1	60	40,450	992	675	95	
	S2	70	39,850	1025	750	100	
	R2	70	39,750	1033	550	65	
	Q1	80	38,200	808	742	100	
	N1	80	37,800	792	692	100	
	Q2	80	38,800	908	667	100	
	N2	80	38,400	900	700	100	
	A6588	Q1	60	39,000	1050	633	100
		N1	60	38,650	925	75	10
		R2	70	39,500	958	175	8
		L2	80	38,150	942	767	100
M1		80	39,000	975	742	100	
Q2		80	39,150	1018	708	100	
R1		80	39,100	925	875	100	
P1		80	39,500	833	817	100	
A6641	G1	50	41,550	1100	775	100	
	L2	50	41,050	1083	533	75	
	J1	50	42,550	1058	117	5	
	G2	60	39,750	958	133	10	
	K2	60	40,100	992	717	100	
	L1	70	40,650	1075	883	100	
	H1	70	40,900	1058	125	8	
	F1	80	38,350	825	842	100	
	J2	80	39,500	908	67	15	
	F2	90	38,900	933	642	100	
	H2	90	38,150	792	817	100	
	K1	90	38,500	900	550	100	
	#1	90	38,900	925	633	100	

TABLE 3-C. CHARPY IMPACT DATA FOR CLASS A AND CLASS B STEELS IN REPRODUCIBILITY STUDY OF LABORATORY STEELS FINISHED AT 1850°F.

HEAT NUMBER	TESTING TEMPERATURE, °F.	CHARPY IMPACT STRENGTH, FT.-LBS.			
		1st. Test	2nd Test	3rd Test	4th Test
A6555	75	32	32	33	32
	60	32	31	30	30
	40	29	29	29	29
	20	26	24	28	8
	0	5	24	23	23
	-40	3	3	3	3
A6556	75	31	31	30	32
	60	28	28	28	27
	40	27	27	27	25
	20	24	24	25	25
	0	10	4	3	3
	-40	3	3	3	3
A6587	75	30	30	33	30
	40	29	27	24	28
	20	23	25	23	22
	0	23	9	19	9
	-40	4	3	3	3
A6650	120	33	35	37	35
	75	31	32	31	29
	40	27	28	24	28
	20	21	6	21	22
	0	11	5	9	18
	-40	3	3	3	3
A6705	75	32	30	32	31
	40	22	27	27	25
	0	18	20	19	19
	-40	2	2	2	3
A6557	75	40	39	41	42
	60	37	40	37	39
	40	36	35	35	35
	20	32	34	33	33
	-20	11	25	24	6
	-60	2	3	8	3
A6584	75	37	40	39	39
	40	34	35	37	36
	0	23	30	9	30
	-40	3	3	20	8
	-80	2	2	2	2

TABLE 3-C. (CONTINUED)

Heat Number	TESTING TEMPERATURE, °F.	CHARPY IMPACT STRENGTH, FT. -LBS			
		1st. Test	2nd Test	3rd Test	4th Test
A6588	75	38	36	38	38
	40	34	36	36	42
	0	28	28	30	30
	-20	27	27	5	22
	-40	3	8	4	4
	-80	2	2	2	2
A6641	75	40	44	41	35
	40	35	39	37	36
	0	26	32	30	34
	-40	21	3	23	4
	-80	2	2	2	2
	A6651	75	38	37	39
40		38	36	35	37
20		33	34	35	35
0		31	33	32	31
-40		3	4	10	17
-80		2	2	2	2

TABLE 4-A. TENSILE-TEST DATA FOR CLASS A AND CLASS B STEELS MADE TO STUDY THE INFLUENCE OF CARBON AND MANGANESE. FINISHING TEMPERATURE - 1650°F.

Grade of Steel	Heat No.	Specimen No.	Yield Strength psi		Tensile Strength, psi..	Elongation in 8 In., %
			Upper	Lower		
(Carbon Series)						
Class A	A-6293	1	35,700	32,900	51,800	36.5
		2	35,500	32,700	51,700	35.5
Class A	A-6294	1	43,200	40,800	72,900	25.5
		2	43,700	41,200	73,000	26.5
Class B	A-6155	1	40,800	40,000	62,100	32.0
		2	41,500	39,800	62,100	31.5
Class B	A-6292	1	50,000	49,500	84,300	23.0
		2	51,300	49,300	84,300	23.5
(Manganese Series)						
Class A	A-6295	1	36,200	34,100	56,100	34.0
		2	35,800	34,000	56,000	32.5
Class A	A-6296	1	46,000	44,800	72,400	28.0
			45,600	44,700	72,400	28.0
Class B	A-6159	1	36,400	35,600	56,800	31.5
		2	36,700	35,500	57,000	31.5
Class B	A-6306	1	45,800	45,200	69,000	31.0
		2	45,300	44,900	69,100	30.0

TABLE 4-B. (CONTINUED)

HEAT NO.	SPECI-MEN NO.	TESTING TEMP., °F.	MAXIMUM LOAD, LBS.	ENERGY TO START FRACTURE, FT.-LBS.	ENERGY TO PROPAGATE FRACTURE, FT.-LBS.	% SHEAR IN FRACTURE
	B2	100	39,000	600	491	100
	D2	100	39,950	641	483	100
	T2	100	39,000	658	475	100
	L1	100	39,250	600	483	100
A-6155	R2	10	42,800	1083	100	3
	G1	10	42,350	1050	50	5
	B2	20	40,500	1225	83	3
	M1	30	43,300	890	825	100
	V2	30	40,300	1000	783	100
	Q1	30	41,150	1000	950	100
	U2	30	41,700	1017	750	100
	F1	40	42,000	900	765	100
	E2	40	41,600	1068	1132	100
	L1	40	41,150	1100	885	100
	C2	40	42,100	1075	757	100
	D1	60	42,800	1120	840	100
	E1	60	42,400	1250	1000	100
	U1	60	41,100	975	807	100
	P2	60	42,200	1060	775	100
	V1	75	40,150	1025	800	100
	R1	75	40,850	1015	725	100
	D2	75	41,300	1215	683	100
	B1	75	41,750	957	800	100
A-6292	D2	60	48,250	775	284	15
	A2	60	47,900	707	58	10
	V1	60	47,800	725	108	5
	P2	60	48,350	833	217	20
	P1	75	48,750	850	375	63
	X2	75	46,500	700	565	100
	F2	75	48,150	715	125	15
	B1	75	49,400	815	125	15
	X1	80	45,200	758	200	10
	S2	80	46,800	691	308	50

TABLE 4-B. (Continued)

Heat No.	Specimen No.	Testing Temp., °F.	Maximum Load, Lbs.	Energy to Start Fracture Ft.-Lbs.	Energy to Propagate Fracture, Ft.-Lbs.	% Shear in Fracture
	U2	90	46,300	666	566	100
	U1	90	46,250	700	591	100
	D1	90	47,200	675	525	100
	S1	90	46,400	733	550	100
(Manganese Series)						
A6295	B2	50	37,250	833	33	5
	G2	50	36,700	865	108	5
	U1	50	36,450	925	25	3
	V2	50	36,100	765	83	3
	F2	60	37,400	950	67	10
	B1	60	36,600	916	750	100
	H2	60	36,150	875	708	100
	W2	60	36,200	1000	142	20
	S2	75	35,500	833	33	2
	M1	75	35,900	933	33	5
	G1	75	35,200	833	633	100
	A1	75	35,850	900	633	100
	A2	90	35,000	741	592	100
	V1	90	34,900	683	425	60
	T1	90	35,250	758	67	3
	F1	90	35,600	867	800	100
	S1	100	34,650	760	666	100
	U2	100	34,200	784	583	100
	C2	100	36,150	816	740	100
	H1	100	35,100	808	790	100
A-6296	N1	10	49,100	1140	158	3
	C2	10	48,850	1250	242	10
	Z1	20	49,100	1190	125	5
	B2	30	47,400	1083	791	100
	D2	30	48,150	1218	575	85
	T1	30	48,250	1208	783	100
	X1	30	47,750	1150	733	100

TABLE 4-B. (Continued)

Heat. No.	Specimen No.	Testing Temp., °F.	Maximum Load, Lbs.	Energy to Start Fracture Ft.-Lbs.	Energy to Propagate Fracture, Ft.-Lbs.	% Shear in Fracture
	B1	40	45,800	1015	708	100
	U1	40	47,750	1210	640	100
	E1	40	48,200	1215	833	100
	X2	40	48,000	1140	690	100
	A2	60	45,100	950	690	100
	D1	60	48,350	1350	875	100
	W2	60	47,150	1110	707	100
	Z2	60	47,650	1160	690	100
	V1	75	45,550	916	692	100
	C1	75	45,100	1166	725	100
	T2	75	46,150	1060	715	100
	E2	75	46,950	1166	766	100
A-6159	N1	40	37,400	950	92	3
	E2	40	38,000	930	92	3
	R1	40	37,050	925	58	3
	P1	40	38,800	1240	92	5
	E1	50	38,000	1075	708	100
	C1	50	38,750	1015	75	5
	M2	50	38,500	1230	58	5
	T1	50	37,050	1040	916	100
	D1	60	37,000	833	858	90
	B1	60	37,000	883	333	5
	Q1	60	37,150	983	765	100
	R2	60	37,850	1100	707	100
	B2	75	37,250	940	680	100
	U1	75	36,000	1020	960	100
	D2	75	37,900	1020	690	100
	S1	75	36,000	980	690	100
A-6306	V1	0	48,600	1381	1050	100
	U1	0	49,500	1425	192	5
	Z2	0	47,700	1300	766	100
	B2	0	50,500	1415	158	5

TABLE 4-B . (Continued)

Heat No.	Specimen No.	Testing Temp., °F.	Maximum Load, Lbs.	Energy to Start Fracture Ft.-Lbs.	Energy to Propagate Fracture, Ft.-Lbs.	% Shear in Fracture
	B1	10	49,550	1400	108	3
	V2	10	48,800	1358	75	20
	C1	20	48,350	1300	67	5
	A1	30	48,900	1425	1000	100
	V1	30	48,300	1350	825	100
	T1	30	46,250	1290	816	100
	W1	30	47,950	1175	791	100
	C2	40	48,000	1208	1000	100
	Y2	40	46,800	1218	858	100
	W2	40	46,800	1208	875	100
	X2	40	46,700	1258	867	100
	U2	60	45,250	1075	800	100
	G1	60	48,500	1350	875	100
	A2	60	48,300	1260	775	100
	X1	60	46,450	1100	775	100
	G2	80	47,750	1240	1050	100
	Z1	80	47,500	1320	800	100
	H1	80	46,200	1080	683	100
	T2	80	46,700	1240	907	100

TABLE 4-C. CHARPY IMPACT DATA FOR CLASS A AND CLASS B STEELS MADE TO STUDY THE INFLUENCE OF CARBON AND MANGANESE. FINISHING TEMPERATURE = 1650°F.

Heat No.	Testing Temp., °F.	Charpy Impact Strength, Ft.-Lbs.			
		1st. Test	2nd Test.	3rd Test	4th Test
(Carbon Series)					
A-6293	75	43	47	39	50
	40	40	45	42	41
	20	45	40	43	40
	-20	33	7	7	6
	-40	25	4	5	5
	-60	3	3	3	3
A-6294	77	18	21	21	20
	40	17	18	20	19
	20	16	13	17	15
	0	13	15	15	14
	-20	9	4	5	4
	-40	5	3	3	2
A-6155	75	43	45	44	44
	40	43	37	40	45
	20	41	36	35	39
	-20	33	29	30	30
	-40	27	28	5	28
	-60	22	4	26	3
	-80	2	25	3	2
A-6292	75	26	26	27	27
	40	26	9	23	21
	20	23	6	23	23
	0	15	20	13	20
	-20	17	18	6	19
	-40	8	17	3	6
(Manganese Series)					
A-6295	75	32	29	24	32
	40	13	32	23	22
	20	5	24	25	18
	0	4	3	3	4
	-20	3	6	3	3
A-6296	75	40	44	42	42
	40	41	39	45	40
	20	39	38	36	40
	-20	40	32	36	33
	-60	28	25	16	27
	-80	2	3	24	2

TABLE 4-C. (Continued)

Heat. No.	Testing Temp., °F.	Charpy Impact Strength, Ft.-Lbs.			
		1st. Test	2nd Test	3rd Test	4th Test
(Manganese Series)					
A-6159	75	36	34	34	35
	40	31	30	30	31
	20	5	27	9	24
	0	5	5	26	6
	-20	4	3	4	3
A-6306	75	47	55	49	49
	40	41	44	50	48
	20	43	46	43	40
	-20	47	38	43	38
	-60	33	4	36	4
	-80	37	37	3	28
		25	2	35	

TABLE 5-A. TENSILE-TEST DATA FOR CLASS A AND CLASS B STEELS MADE TO STUDY THE INFLUENCE OF CARBON AND MANGANESE. FINISHING TEMPERATURE = 1850° F.

Grade of Steel	Heat No.	Specimen No.	Yield Strength, Psi		Tensile Strength, psi.	Elongation in 8 In., %
			Upper	Lower		
(Carbon Series)						
Class A	A-6539	1	31,600	30,900	53,400	31.0
		2	32,100	30,600	53,200	30.0
Class A	A-6596	1	43,600	40,000	75,000	25.5
		2	39,000	37,100	70,800	22.0
Class B	A-6586	1	32,300	31,300	53,800	28.5
		2	33,700	32,700	55,000	28.0
Class B	A-6597	1	41,900	41,200	75,600	24.5
		2	39,900	39,000	74,600	25.0
(Manganese Series)						
Class A	A-6589	1	33,900	33,300	58,100	29.0
		2	34,200	32,800	58,700	30.0
Class A	A-6598	1	43,200	42,600	75,100	23.0
		2	42,500	41,700	73,300	23.0
Class B	A-6590	1	33,100	32,000	55,200	30.0
		2	33,100	30,900	55,000	31.0
Class B	A-6599	1	44,000	43,500	72,400	24.0
		2	43,700	43,300	72,300	25.0

TABLE 5-B. NAVY TEAR-TEST DATA FOR CLASS A AND CLASS B
STEELS MADE TO STUDY THE INFLUENCE OF CARBON
AND MANGANESE, FINISHED AT 1850 F.

Heat No.	Specimen No.	Testing Temp., °F.	Maximum Load, Lbs.	Energy to Start Fracture, Ft.-Lbs.	Energy to Propagate Fracture, Ft.-Lbs.	% Shear in Fracture	
A-6539	B1	30	38,850	1150	108	15	
	T2	40	36,100	1018	666	100	
	L2	40	35,300	866	133	5	
	D1	50	35,300	833	116	5	
	M2	60	34,900	875	650	100	
	C1	60	36,100	950	666	100	
	T1	60	35,850	1008	542	70	
	D2	60	36,350	892	158	10	
	A1	70	34,900	925	584	85	
	M1	70	35,400	983	675	100	
	S1	70	35,750	950	650	100	
	L1	70	35,050	858	866	100	
	A-6596	Q2	90	37,700	608	100	10
		N1	100	37,350	542	50	10
N2		110	36,600	558	183	15	
L2		120	36,650	500	308	40	
R1		130	35,250	525	533	100	
M2		130	35,650	466	525	100	
L1		130	35,900	508	567	100	
R2		130	36,700	583	667	100	
A-6586		M1	20	39,250	1283	567	75
	P1	20	39,600	1408	208	10	
	R2	30	38,900	1350	292	25	
	Q1	40	37,900	1250	108	5	

TABLE 5-B. (Continued)

Heat Number	Specimen Number	Testing Temperature °F.	Maximum Load, Pounds	Energy to Start Fracture, Ft.-Lbs.	Energy to Propagate Fracture, Ft.-Lbs.	% Shear in Fracture
	N1	50	37,500	1225	933	100
	P2	50	38,150	1225	992	100
	L1	50	38,450	1375	1838	100
	R1	50	38,200	1250	683	95
A6597	M1	80	39,150	542	33	3
	N2	90	40,350	566	300	45
	H1	100	42,350	617	575	100
	J2	100	42,550	700	558	100
	M2	100	40,500	600	658	100
	K2	100	40,950	650	633	100
<u>Manganese Series</u>						
A6589	A2	90	36,250	800	692	100
	C2	90	36,600	858	707	100
	N1	90	35,500	741	650	100
	M1	90	34,400	666	100	10
	B2	100	33,900	700	708	100
	M2	100	34,600	683	100	10
	C1	110	34,800	972	725	100
	D2	110	34,700	725	733	100
	A1	110	35,650	791	625	100
	N2	110	35,450	775	616	100
A6598	M2	50	45,900	1083	492	40
	L1	60	46,450	1142	75	5
	Q1	70	46,800	925	925	100
	R2	70	46,000	875	783	95
	L2	70	43,500	892	400	30
	P2	80	44,700	900	817	100
	Q2	80	46,150	1183	817	100
	R1	80	44,950	817	892	100
	N1	80	45,000	917	800	100

TABLE 5-B. (Continued)

Heat Number	Specimen Number	Testing Temperature OF.	Maximum Load, Pounds	Energy to Start Fracture, Ft.-Lbs.	Energy to Propagate Fracture, Ft.-Lbs.	% Shear in Fracture	
A6590	R1	90	34,150	800	742	100	
	S2	90	34,700	825	750	100	
	H1	90	34,750	807	758	100	
	F2	90	34,800	875	83	15	
	S1	100	33,150	807	650	100	
	R2	100	32,600	775	866	100	
	F1	100	34,900	950	850	100	
	G1	100	33,800	815	600	100	
	A6599	M1	20	49,000	1292	125	2
		N2	30	46,850	1183	183	10
S1		40	46,850	1108	92	3	
Q2		50	46,700	925	258	8	
R2		60	46,750	1058	333	20	
P1		60	46,900	1118	550	50	
N1		70	45,550	842	900	100	
Q1		70	45,750	842	858	100	
R1		70	45,950	1042	758	100	
M2		70	47,950	1150	892	100	

TABLE 5-C. CHARPY IMPACT DATA FOR CLASS A AND CLASS B STEELS MADE TO STUDY THE INFLUENCE OF CARBON AND MANGANESE, FINISHED AT 1850°F.

Heat Number	Testing Temperature, OF.	<u>Charpy Impact Strength, Ft.-Lbs.</u>			
		1st. Test	2nd. Test	3rd. Test	4th Test
<u>Carbon Series</u>					
A6539	75	42	32	37	39
	40	34	26	34	34
	20	27	7	26	25
	0	6	19	21	8
	-20	5	5	4	4
	-40	3	3	3	3
A6596	75	20	20	20	19
	40	14	16	14	16
	0	9	3	6	4
	-40	2	2	2	2
A6586	75	54	55	56	56
	40	46	50	57	62
	0	49	44	51	56
	-20	37	7	39	38
	-40	4	6	5	5
	-80	2	2	2	2
A6597	75	27	26	25	26
	40	23	22	25	25
	20	22	20	20	20
	0	5	10	19	7
	-40	3	3	3	3
<u>Manganese Series</u>					
A6589	75	29	25	28	30
	60	23	24	24	26
	40	17	24	22	22
	20	17	19	5	18
	0	4	4	4	5
	-40	2	2	2	2
A6598	75	41	42	41	40
	40	37	38	38	37
	0	33	31	33	31
	-40	27	25	28	27
	-80	15	3	2	22

TABLE 5-C. (Continued.)

Heat Number	Testing Temperature °F.	Charoy Impact Strength, Ft.-Lbs.			
		1st. Test	2nd. Test	3rd. Test	4th Test
A6590	75	33	32	35	30
	60	28	31	30	30
A6590	40	28	21	29	26
	20	6	22	5	25
	0	4	13	5	5
	-40	3	3	3	3
A6599	75	51	47	49	53
	40	41	45	50	49
	0	39	35	41	38
	-40	5	31	5	32
	-80	2	2	2	2

TABLE 6-A. TENSILE-TEST DATA FOR CLASS A AND CLASS B STEELS MADE TO STUDY THE INFLUENCE OF PHOSPHORUS AND SULPHUR, FINISHED AT 1850°F.

Grade of Steel	Heat Number	Specimen Number	Yield Strength psi		Tensile Strength psi.	Elongation in 8 In., %
			Upper	Lower		
Class A	A6135	1	34,500	33,200	59,200	29.0
		2	35,000	33,000	59,000	28.0
Class A	A6652	1	37,800	36,500	64,000	23.5
		2	36,900	36,000	64,000	23.5
Class A	A6706	1	39,400	37,900	67,300	22.0
		2	39,900	39,100	67,200	20.5
Class B	A6638	1	36,500	34,400	61,400	28.0
		2	35,500	33,900	61,900	29.0
Class B	A6653	1	39,100	36,400	64,700	24.5
		2	38,100	36,700	64,800	25.5
Class B	A6655	1	40,800	38,400	67,500	24.0
		2	40,800	38,100	67,400	23.5
Class A	A6647	1	39,000	35,500	61,900	27.5
		2	38,200	35,600	62,100	25.0
Class B	A6646	1	37,800	36,400	62,400	26.0
		2	37,000	35,900	61,900	31.0

TABLE 6-B. NAVY TEAR-TEST DATA FOR CLASS A AND CLASS B STEELS
MADE TO STUDY THE INFLUENCE OF PHOSPHORUS AND
SULPHUR, FINISHED AT 1850°F.

Heat Number	Specimen Number	Testing Temperature, °F.	Maximum Load, Pounds	Energy to Start Fracture, Ft. - Lbs.	Energy to Propagate Fracture, FT.-Lbs.	% Shear in Fracture
A6135	D1	80	35,400	650	100	10
	F1	90	35,300	708	683	100
	K1	90	35,350	716	675	100
	E1	90	34,500	683	675	100
	C2	90	36,250	750	758	100
A6652	H1	60	37,850	717	92	5
	D2	70	39,250	850	67	3
	E2	80	39,800	967	67	5
	F2	90	38,450	817	67	5
	D1	100	38,900	750	758	85
	G1	100	38,350	742	67	10
	J2	110	37,800	863	167	30
	E1	120	38,600	850	550	95
	H2	120	38,200	767	533	100
	F1	120	40,400	933	550	100
J1	120	38,400	850	700	100	
A6706	Q1	110	38,200	800	616	100
	N2	110	38,000	800	133	15
	L2	120	37,000	667	650	100
	R1	120	38,200	733	567	100
	N1	120	38,100	800	567	100
	P1	120	39,200	733	783	100
A6638	N2	30	39,100	825	150	5
	P1	40	39,100	1042	125	10
	S1	50	39,250	933	717	100
	R2	50	40,450	1275	625	100
	M2	50	39,350	1133	600	70
	Q2	50	39,550	1042	400	45

TABLE 6-B. (Continued)

Heat Number	Specimen Number	Testing Temperature, °F.	Maximum Load, Pounds	Energy to Start Fracture, Ft.-Lbs.	Energy to Propagate Fracture, Ft. - Lbs.	% Shear in Fracture
A6638	N1	60	38,700	992	600	100
	M1	60	37,650	892	267	20
	P2	70	37,700	925	758	100
	R1	70	38,500	983	666	100
	Q1	70	38,400	867	625	100
	S2	70	38,100	975	691	100
A6653	T1	50	39,650	825	150	5
	N2	60	40,850	917	808	5
	S2	60	38,600	950	67	3
	Q1	70	40,300	1033	83	3
	P1	80	38,900	850	667	80
	R1	80	40,400	992	800	100
	T2	80	39,550	942	67	5
	N1	90	40,650	908	150	5
	R2	100	38,900	917	583	100
	P2	100	39,450	858	775	100
	S1	100	39,350	908	967	100
	Q2	100	39,850	863	683	100
	A6655	Q2	50	41,600	817	67
R1		60	41,000	883	67	3
N2		70	41,650	842	158	3
P2		80	41,400	833	75	3
S2		90	40,300	833	67	3
N1		100	40,950	833	100	10
Q1		110	41,600	950	230	10
T1		120	39,800	833	667	100
R2		120	40,800	833	667	100
P1		120	42,000	933	750	100
T2		120	41,600	933	466	55

TABLE 6-B. (Continued)

Heat Number	Specimen Number	Testing Temperature °F	Maximum Load, Pounds	Energy to Start Fracture, Ft.- Lbs.	Energy to Propagate Fracture	% Shear in Fracture	
A6647	Q2	50	35,550	825	515	100	
	P2	50	37,650	863	550	100	
	N2	50	36,500	616	58	5	
	L1	60	38,050	817	100	8	
	K2	70	36,300	717	675	100	
	M1	70	36,000	675	600	100	
	P1	70	35,300	675	642	100	
	Q1	70	35,800	717	750	100	
	A6646	R1	50	39,500	842	708	100
		Q2	50	39,800	975	583	70
N2		50	38,800	850	108	8	
Q1		60	38,600	900	733	100	
N1		60	38,700	900	725	100	
R2		60	38,900	817	742	100	
L1		60	39,350	983	683	100	

TABLE 6-C. CHARPY IMPACT DATA FOR CLASS A AND CLASS B STEELS MADE TO STUDY THE INFLUENCE OF PHOSPHORUS AND SULPHUR, FINISHED AT 1850°F.

Heat Number	Testing Temperature, °F.	Charpy Impact Strength, Ft.-Lbs.			
		1st. Test	2nd Test	3rd Test	4th Test
<u>Phosphorus Series</u>					
A6135	75	31	31	30	31
	40	29	28	25	29
	0	22	22	22	23
	-20	5	4	4	5
	-40	3	3	3	6
A6652	120	32	32	32	32
	75	28	27	28	29
	40	26	23	27	23
	20	20	18	19	22
	0	10	17	17	19
	-40	2	2	2	2
A6706	75	29	27	28	21
	40	8	22	19	22
	0	16	10	4	4
	-40	2	3	2	2
A6658	75	40	39	40	38
	40	34	37	35	37
	0	33	31	29	31
	-20	26	22	24	28
	-40	3	3	5	3
A6653	120	40	40	45	41
	75	36	38	38	39
	40	33	33	33	35
	0	24	26	28	26
	-20	24	4	24	4
	-40	3	3	4	3
A6655	120	35	40	39	37
	75	35	32	34	33
	40	15	31	27	29
	20	26	22	23	28
	0	24	20	21	18
	-40	2	2	3	3

TABLE 6-C. (Continued)

Heat Number	Testing Temperature, °F.	Charpy Impact Strength, Ft.-Lbs.			
		1st Test	2nd Test	3rd Test	4th Test
<u>Sulphur Series</u>					
A6647	75	31	30	31	29
	40	26	26	28	27
	20	25	23	25	23
	0	21	21	6	6
	-40	3	3	4	3
A6646	75	30	40	37	41
	40	39	33	33	32
	0	27	30	30	30
	-40	23	5	21	5
	-80	3	2	2	2

TABLE 7-A. TENSILE-TEST DATA FOR CLASS A AND CLASS B STEELS MADE TO STUDY THE INFLUENCE OF SILICON, FINISHED AT 1850°F.

Grade of Steel	Heat Number	Specimen Number	Yield Strength, psi.		Tensile Strength, psi.	Elongation in 8 In., %
			Upper	Lower		
Class A	A6602	1	33,800	33,200	60,400	31.5
		2	33,300	32,700	59,600	30.0
Class A	A6594	1	37,100	35,500	62,400	30.0
		2	37,100	35,900	62,500	30.0
Class A	A6657	1	33,900	33,600	63,400	25.5
		2	34,500	33,700	63,300	28.0
Class A	A6696	1	37,400	36,300	67,100	27.0
		2	37,400	37,000	67,300	25.5
Class B	A6603	1	38,200	37,600	65,800	21.0
		2	36,900	36,100	64,000	25.0
Class B	A6595	1	38,500	36,100	64,100	27.5
		2	38,200	36,200	62,700	27.5
Class B	A6695	1	38,400	37,100	64,600	27.0
		2	38,500	36,300	64,000	26.0
Class B	A6697	1	38,800	37,800	67,000	29.0
		2	39,300	37,800	66,800	30.5

TABLE 7-B. NAVY TEAR-TEST DATA FOR CLASS A AND CLASS B STEELS MADE TO STUDY THE INFLUENCE OF SILICON FINISHED AT 1850°F.

Heat Number	Specimen Number	Testing Temperature °F.	Maximum Load, Pounds	Energy to Start Fracture, Ft.-Lbs.	Energy to Propagate Fracture, Ft.-Lbs.	% Shear in Fracture	
A6602	R2	50	37,800	850	167	10	
	Q1	60	36,950	900	92	3	
	N1	70	35,400	750	658	100	
	L2	70	37,000	825	533	65	
	Q2	70	36,350	825	133	10	
	P1	80	36,400	767	658	100	
	M2	80	35,900	784	692	100	
	L1	80	36,750	817	58	8	
	R1	90	36,500	716	617	100	
	M1	90	35,150	708	833	100	
	N2	90	35,900	850	642	100	
	P2	90	35,350	792	670	100	
	A6594	E2	50	38,650	934	92	10
		Q2	60	37,900	950	25	8
		N2	70	38,650	833	600	100
R2		70	39,200	825	800	100	
Q1		70	38,500	867	67	15	
F1		80	37,500	867	200	25	
N1		90	38,650	866	950	100	
R1		90	37,000	825	750	100	
P2		90	38,100	775	858	100	
E1		90	38,600	775	758	100	
A6657		N1	60	38,650	1800	125	100
	Q2	60	38,300	717	100	10	
	S1	70	38,550	692	808	100	
	T2	70	37,650	800	625	100	
	P1	70	38,300	858	166	10	
	R1	80	38,700	883	733	100	
	N2	80	37,900	783	583	100	
	Q1	80	37,750	807	650	100	
	P2	80	37,450	875	650	100	

TABLE 7-B. (CONTINUED)

Heat Number	Specimen Number	Testing Temperature, °F.	Maximum Load, Pounds	Energy to Start Fracture, Ft.-Lbs	Energy to Propagate Fracture, Ft.-Lbs.	% Shear in Fracture
A6696	T1	40	40,700	733	50	3
	U2	50	40,850	767	100	10
	P1	60	39,900	708	67	5
	R2	70	40,250	825	150	15
	S1	80	40,100	767	658	100
	Q1	80	40,400	833	775	100
	R1	80	40,200	808	750	100
	U1	80	40,750	800	767	100
	A6603	P2	50	39,850	883	158
M1		60	39,900	1058	658	100
R2		60	40,900	1058	67	5
Q1		70	37,700	842	683	100
L1		70	38,700	1033	742	100
N2		70	39,700	1108	692	100
M2		70	38,350	825	83	10
R1		80	38,700	875	133	10
L2		90	39,500	950	700	100
Q2		90	38,800	950	758	100
P1		90	38,500	817	733	100
N1		90	38,500	750	742	100
A6595		P2	30	42,050	1068	616
	Q1	30	40,700	900	792	100
	N1	30	40,900	863	100	10
	M2	40	41,250	1000	58	3
	R2	50	41,200	1150	783	100
	M1	50	38,500	858	633	100
	N2	50	41,400	1025	808	100
	L1	50	41,000	1042	675	100
	A6695	R1	20	42,550	892	558
S2		20	42,950	942	92	3

TABLE 7-B, (CONTINUED)

Heat Number	Specimen Number	Testing Temperature, °F.	Maximum Load, Pounds	Energy to Start Fracture Ft.-Lbs.	Energy to Propagate Fracture, Ft.-Lbs.	% Shear in Fracture
A6695	T2	30	42,150	858	480	45
	P2	40	42,100	1025	716	100
	R2	40	41,050	825	808	100
	N2	40	42,400	991	616	100
	T1	40	41,650	908	691	100
A6697	N1	20	44,150	892	125	3
	P2	30	42,800	863	83	3
	R1	40	43,050	917	100	5
	T2	50	41,800	942	633	100
	Q1	50	43,100	1016	775	100
	N2	50	42,500	883	208	5
	S1	60	42,300	933	100	5
	T1	70	41,650	883	741	100
	Q2	70	41,350	975	741	100
	R2	70	41,550	983	758	100
	P1	70	42,050	1025	675	100

TABLE 7-C. CHARPY IMPACT DATA FOR CLASS A AND CLASS B STEELS
MADE TO STUDY THE INFLUENCE OF SILICON, FINISHED
AT 1850°F.

Heat Number	Testing Temperature, °F.	Charpy Impact Strength, Ft-Lbs			
		1st. Test	2nd. Test	3rd. Test	4th. Test
A6602	75	32	29	31	33
	40	28	29	27	25
	20	18	25	20	7
	0	10	20	20	17
	-40	2	3	3	3
A6594	75	33	33	32	33
	60	32	32	30	31
	40	29	28	30	30
	20	28	26	29	26
	-20	19	19	5	20
	-60	3	4		
A6657	120	40	40	40	38
	75	34	31	34	36
	40	30	28	28	31
	0	23	24	25	23
	-20	8	15	6	22
	-40	5	4	5	4
A6696	75	31	33	32	32
	40	27	27	31	28
	0	23	24	24	22
	-20	21	23	20	22
	-40	15	16	19	17
	-80	2	3	3	2
A6603	75	38	38	38	36
	40	34	35	36	33
	0	30	29	27	26
	-20	25	25	26	24
	-40	22	20	4	3
	-80	2	2	2	2
A6595	75	38	45	45	42
	40	38	37	37	39
	0	31	29	32	31
	-40	24	28	28	5
	-80	3	2	2	2
A6695	75	39	39	39	40
	40	35	38	36	37
	0	31	31	31	31
	-40	29	27	28	27
	-80	19	6	5	5

TABLE 7-C. (CONTINUED)

Heat Number	Testing Temperature, of.	Charpy Impact Strength, Ft.-Lbs.			
		1st. Test	2nd. Test	3rd. Test	4th. Test
A6697	75	45	42	42	44
	40	37	37	40	40
	0	33	31	29	30
	-20	28	26	24	23
	-40	20	5	13	5
	-80	2	3	2	2

TABLE 8-A. TENSILE-TEST DATA FOR CLASS A AND CLASS B STEELS
MADE TO STUDY THE INFLUENCE OF VANADIUM, FINISHED
AT 1850°F.

Grade of Steel	Heat No.	Specimen No.	Yield Strength, psi.		Tensile Strength, psi.	Elongation in 8 In., %
			Upper	Lower		
Class A	A-6642	1	44,800	40,000	66,900	22.5
		2	45,100	41,700	68,900	23.5
Class A	A-6368	1	45,000	44,500	68,400	25.0
		2	45,600	44,400	67,600	25.0
Class A	A-6366	1	57,300	53,700	78,400	20.0
		2	57,300	54,100	78,400	20.0
Class B	A-6643	1	44,600	42,600	69,100	23.5
		2	43,200	42,500	68,000	21.0
Class B	A-6644	1	51,800	49,500	73,700	18.5
		2	50,700	48,300	72,700	19.0
Class B	A-6645	1	63,100	60,700	85,100	16.0
		2	62,900	59,800	85,000	15.0

TABLE 8-B NAVY TEAR TEST DATA FOR CLASS A AND CLASS B STEELS
MADE TO STUDY THE INFLUENCE OF VANADIUM, FINISHED
AT 1850°F.

Heat No.	Specimen No.	Testing Temp. °F.	Maximum Load, Lbs.	Energy to Start Fracture, Ft.-Lbs.	Energy to Propagate Fracture, Ft.-Lbs.	% Shear in Fracture	
A-6642	K1	70	39,700	625	67	3	
	H1	80	39,400	663	125	5	
	J2	80	40,100	767	517	95	
	K2	80	39,050	600	58	10	
	J1	90	38,850	708	750	85	
	F2	90	38,450	658	642	100	
	G2	90	37,500	608	575	90	
	E2	90	39,600	633	508	100	
	A-6368	E2	80	42,100	716	150	5
		N2	90	40,800	691	641	100
B2		90	41,000	666	175	5	
F2		100	40,050	475	416	50	
P1		100	39,500	625	557	100	
N1		100	40,850	733	716	100	
C2		100	40,100	617	617	80	
P2		110	40,100	675	618	100	
E1		110	41,400	600	641	90	
A2		110	41,000	591	808	100	
C1		110	41,400	700	600	100	
A-6366		E1	80	48,250	641	167	0
	F2	90	46,750	700	75	3	
	C2	100	47,250	650	75	3	
	N1	110	46,550	550	50	1	
	B2	120	45,650	541	92	5	

TABLE 8-B. (Continued)

Heat No.	Specimen No.	Testing Temperature, °F.	Maximum Load, Lbs.	Energy to Start Fracture, Ft.-Lbs.	Energy to Propagate Fracture, Ft.-Lbs.	% Shear in Fracture
	D2	130	45,700	658	75	5
	N2	130	46,850	608	83	10
	P1	140	45,700	608	117	5
	F1	150	45,800	650	150	15
	E2	160	45,400	558	541	85
	D1	160	45,250	742	400	75
	P2	160	46,100	591	125	10
	A2	170	44,000	566	608	100
	C1	170	45,650	557	442	95
	A1	170	43,250	467	450	100
	B1	170	44,700	500	541	100
A-6643	P1	70	42,600	950	625	100
	Q1	70	40,500	883	742	85
	U1	70	42,800	900	742	100
	T2	70	41,600	850	67	10
	T1	80	41,600	833	750	100
	Q2	80	43,050	767	842	100
	R2	80	43,100	908	800	100
	S2	80	42,450	708	658	100
A-6644	R1	80	44,350	675	650	90
	N2	80	44,600	675	75	2
	P2	90	44,400	708	67	2
	N1	100	44,750	792	250	10
	P1	110	43,300	725	725	100
	Q2	110	43,700	717	817	100
	S2	110	42,750	583	875	100
	M1	110	44,550	742	717	100
A-6645	N1	100	54,300	667	107	3
	Q2	110	51,700	667	133	3
	S2	120	49,200	667	333	25
	P2	130	54,200	700	83	0

TABLE 8-B. (Continued)

Heat No.	Specimen No.	Testing Temp. °F.	Maximum Load, Lbs.	Energy to Start Fracture, Ft.-Lbs.	Energy to Propagate Fracture, Ft.-Lbs.	% Shear in Fracture
	R1	140	53,200	833	133	3
	N2	150	52,700	650	117	5
	T1	150	51,800	600	100	10
	T2	160	49,950	483	550	100
	F1	160	53,800	400	33	10
	U1	170	49,900	517	517	100
	S1	170	52,800	617	600	100
	U2	170	51,500	467	583	100
	R2	170	51,700	517	517	100

TABLE 8-C. CHARPY IMPACT DATA FOR CLASS A AND CLASS B STEELS
MADE TO STUDY THE INFLUENCE OF VANADIUM, FINISHING
TEMPERATURE - 1850°F.

Heat No.	Testing Temp., F.	Charpy Impact Strength, Ft.-Lbs.			
		1st Test	2nd Test	3rd Test	4th Test
(Vanadium Series)					
A-6642	75	30	29	30	29
	40	26	28	25	24
	20	21	22	23	23
	0	17	18	18	4
	-40	3	3	3	3
A-6368	75	28	27	28	28
	40	25	26	24	24
	20	22	22	21	22
	0	17	17	19	16
	-20	3	4	3	11
-40	2	3	3	2	
A-6366	90	22	22	18	22
	75	20	20	20	20
	60	17	17	17	19
	40	7	8	16	7
	0	3	2	3	3
A-6643	75	40	39	45	40
	40	39	38	40	38
	0	28	31	28	32
	-20	27	26	22	28
	-40	24	11	4	8
	-80	3	2	3	5
A-6644	75	35	35	33	34
	40	32	34	28	32
	0	22	26	23	27
	-20	17	20	22	24
	-40	5	4	5	7
	-80	2	2	2	3

TABLE 8-C. (Continued)

Heat No.	Testing Temp., °F.	Charpy Impact Strength, Ft. -Lbs.			
		1st Test	2nd Test	3rd Test	4th Test
(Vanadium Series)					
A-6645	120	25	27	24	27
	75	21	20	24	21
	60	17	13	11	21
	40	9	6	8	19
	0	3	5	4	3
