

Fourth

PROGRESS REPORT

(Project SR-99)

on

**THE FUNDAMENTAL FACTORS INFLUENCING
THE BEHAVIOR OF WELDED STRUCTURES:**

The Effect of Subcritical Heat Treatment
on the Transition Temperature of a Low Carbon Ship Plate Steel

and

Supplement on
Embrittlement of "C" Steel by Nitrogen

by

E. B. Evans and L. J. Klingler

CASE INSTITUTE OF TECHNOLOGY

Transmitted through

**NATIONAL RESEARCH COUNCIL'S
COMMITTEE ON SHIP STEEL**

Advisory to

SHIP STRUCTURE COMMITTEE

Division of Engineering and Industrial Research

National Academy of Sciences - National Research Council

Washington, D. C.

October 30, 1953

SERIAL NO. **SSC-60**
BuShips Project NS-011-078

SHIP STRUCTURE COMMITTEE

MEMBER AGENCIES:

BUREAU OF SHIPS, DEPT. OF NAVY
MILITARY SEA TRANSPORTATION SERVICE, DEPT. OF NAVY
UNITED STATES COAST GUARD, TREASURY DEPT.
MARITIME ADMINISTRATION, DEPT. OF COMMERCE
AMERICAN BUREAU OF SHIPPING

ADDRESS CORRESPONDENCE TO:

SECRETARY
SHIP STRUCTURE COMMITTEE
U. S. COAST GUARD HEADQUARTERS
WASHINGTON 25, D. C.

October 30, 1953

Dear Sir:

As part of its research program related to the improvement of hull structures of ships, the Ship Structure Committee is sponsoring an investigation on "The Fundamental Factors Influencing the Behavior of Welded Structures under Conditions of Multiaxial Stress and Variations of Temperature" at the Case Institute of Technology. Herewith is a copy of the Fourth Progress Report, SSC-60, of the investigation, entitled "The Fundamental Factors Influencing the Behavior of Welded Structures: The Effect of Subcritical Heat Treatment on the Transition Temperature of a Low Carbon Ship Plate Steel" by E. B. Evans and L. J. Klingler.

The project is being conducted with the advisory assistance of the Committee on Ship Steel of the National Academy of Sciences-National Research Council.

Any questions, comments, criticism or other matters pertaining to the Report should be addressed to the Secretary, Ship Structure Committee.

This Report is being distributed to those individuals and agencies associated with and interested in the work of the Ship Structure Committee.

Yours sincerely,



K. K. COWART
Rear Admiral, U. S. Coast Guard
Chairman, Ship Structure Committee

FOURTH
Progress Report
(Project SR-99)

on

The Fundamental Factors Influencing
the Behavior of Welded Structures:
The Effect of Subcritical Heat Treatment
on the Transition Temperature of a Low Carbon Ship Plate Steel
and
Supplement on
Embrittlement of "C" Steel by Nitrogen

by

E. B. Evans
L. J. Klingler

CASE INSTITUTE OF TECHNOLOGY

under

Department of the Navy
Bureau of Ships NCbs-45470
BuShips Project No. NS-011-078

for

SHIP STRUCTURE COMMITTEE

TABLE OF CONTENTS

	Page
Contents	i
List of Figures	ii
Abstract	vi
Introduction	1
Material	3
Procedure	4
Specimen Preparation	4
Subcritical Heat Treatment	6
Cooling Curves	8
Testing Procedure	8
Results	
Transition Temperatures and Hardnesses	11
Base Plate	17
Air Cooled	19
Furnace Cooled	23
Water Quenched	24
Microstructures	34
Cooling Curves	36
Discussion	38
Conclusions	45
Future Work	46
Acknowledgments	46
Bibliography	47
Appendix	
A. Eccentric Notch Tensile Transition Curves and Method of Determination of Eccentric Notch Tensile Transition Temperature	48
B. Charpy V-Notch Transition Curves Plate II	58
Supplement	
Embrittlement of "C" Steel by Nitrogen	67

LIST OF FIGURES

<u>No.</u>	<u>Title</u>	<u>Page</u>
1.	Test Specimens	5
2.	Preparation of Charpy V-Notch and Notch Tensile Specimens from "C" Steel Plate.	7
3.	Method of Loading to Obtain 1/4-Inch Eccentricity. (Eccentricity and the Position of Fixtures are Exaggerated.)	9
4.	Comparison of Eccentric Notch Tensile Transition Behavior for Two Different Plates of As-Received "C" Steel	18
5.	Eccentric Notch Tensile Transition Temperatures of "C" Steel as a Function of Time at Various Subcritical Temperatures. Air Cooled.	20
6.	Charpy V-Notch Transition Temperature as a Function of Time at Subcritical Temperatures. Air Cooled. Plate II.	22
7.	Transition Temperatures of "C" Steel as a Function of Time at Subcritical Temperatures. Water Quenched and Aged One Month at Room Temperature. Plate II.	26
8.	Effect of Room Temperature Aging Time on Charpy V-Notch Transition Curves of "C" Steel	29
9.	Effect of Room Temperature Aging Time on the Charpy V-Notch Transition Temperature and Hardness of "C" Steel	29
10.	Effect of Room Temperature Aging Time on Charpy V-Notch Transition Curves of "C" Steel	32
11.	Comparison of Charpy V-Notch Transition Curves for Room Temperature and Accelerated Aging of "C" Steel.	32

<u>No.</u>	<u>Title</u>	<u>Page</u>
12.	Microstructures of "C" Steel in the As-Received Condition and after Various Subcritical Heat Treatments	35
13.	Comparison of Cooling Curves in the Region of Lowest Ductility for Two Welding Conditions with those Obtained with Heat Treated Test Specimens	37
14.	Heating and Cooling Curves in the Region of Lowest Ductility for Two 6 Pass Weldments .	44
1A.	Eccentric Notch Tensile Transition Curve of As-Received "C" Steel. Plate II.	50
2A.	Eccentric Notch Tensile Transition Curves of "C" Steel. Subcritically Heated at 700°F for Times Indicated and Air Cooled.	51
3A.	Eccentric Notch Tensile Transition Curves of "C" Steel. Subcritically Heated at 800°F for Times Indicated and Air Cooled.	52
4A.	Eccentric Notch Tensile Transition Curves for "C" Steel. Subcritically Heated at 950°F for Times Indicated and Air Cooled.	53
5A.	Eccentric Notch Tensile Transition Curves for "C" Steel. Subcritically Heated at 1100°F for Times Indicated and Air Cooled. Plate II	54
6A.	Eccentric Notch Tensile Curves of "C" Steel. Subcritically Heated at 1200°F for Times Indicated and Air Cooled. Plate II	55
7A.	Eccentric Notch Tensile Transition Curves for "C" Steel. Subcritically Heated at 1100°F for Times Indicated and Water Quenched. Aged 1 Month at Room Temperature. Plate II	56
8A.	Eccentric Notch Tensile Transition Curves of "C" Steel. Subcritically Heated at 1200°F for Times Indicated and Water Quenched. Aged 1 Month at Room Temperature. Plate II	57

<u>No.</u>	<u>Title</u>	<u>Page</u>
1B.	Charpy V-Notch Transition Curves for As-Received "C" Steel	59
2B.	Charpy V-Notch Transition Curves for "C" Steel. Subcritically Heated at 1100°F for Times Indicated and Air Cooled	60
3B.	Charpy V-Notch Transition Curves for "C" Steel. Subcritically Heated at 1200°F for Times Indicated and Air Cooled	61
4B.	Charpy V-Notch Transition Curves for "C" Steel. Subcritically Heated at 1100°F for Times Indicated and Furnace Cooled	62
5B.	Charpy V-Notch Transition Curves for "C" Steel. Subcritically Heated at 1200°F for 1/2 Minute and Furnace Cooled.	62
6B.	Charpy V-Notch Transition Curves for "C" Steel. Subcritically Heated at 1100°F for Times Indicated and Water Quenched. Aged 1 Month at Room Temperature	63
7B.	Charpy V-Notch Transition Curves for "C" Steel. Subcritically Heated at 1200°F for Times Indicated and Water Quenched. Aged at Room Temperature.	64

SUPPLEMENT

1.	Charpy V-Notch Transition Curves of "C" Steel After Various Subcritical Heat Treatments in Nitrate Salt	69
2.	Eccentric Notch Tensile Transition Curves of "C" Steel After Various Subcritical Heat Treatments in Nitrate Salt	71
3.	Transition Temperatures of "C" Steel Resulting from Various Subcritical Heat Treatments in Nitrate Salt Bath and in Air, Employing an Air Cool	73

<u>No.</u>	<u>Title</u>	<u>Page</u>
4.	Transition Temperatures of "C" Steel Resulting from Heating at 1100°F for Various Times in Nitrate Salt Bath and in Air, Employing a Water Quench. Aged One Month at Room Temperature	75
5.	Charpy Transition Temp.-Isothermal Time Curves After Heat Treatment at 1100°F in Nitrate Salt Bath and in Air	77
6.	Charpy Transition Curves After Heat Treatment at 1100°F for 112 Hours in Nitrate Salt Bath and in Air	77
7.	Microstructures of "C" Steel in the As-Received Condition and After Various Subcritical Heat Treatments in Nitrate Salt Bath and in Air. Nital Etch. 2000X.	79
8.	Microstructures of "C" Steel at 2000X After Following Heat Treatments	85

ABSTRACT

The dependence of transition temperature upon subcritical heat treatment has been investigated in a low carbon ship plate steel (Project Steel "C"). The effect of time at temperature in the 700°--1200°F range has been determined, employing three different cooling rates--air cool, furnace cool, water quench. In addition, a limited study was made of the room temperature and the accelerated aging effects after water quenching from 1200°F. The degree of embrittlement was evaluated by means of eccentric notch tensile and Charpy V-notch impact tests, with the as-received plate as a basis of comparison.

For the air cooled series, the transition temperature-isothermal time relationship obtained with impact specimens indicated no embrittlement at the shorter times, but a slight embrittlement was present after long times at either 1100° or 1200°F. In contrast, notch tensile specimens revealed a slight, constant embrittlement at the shorter times which was decreased or eliminated at the longer times in the 700°--1200°F range.

With a furnace cool, spot checks made with impact specimens showed the same transition behavior as specimens heat treated and air cooled.

For the series quenched from 1100°F (aged one month at room temperature), the plot of transition temperature vs.

isothermal time indicated a severe embrittlement at all isothermal times, i.e., the entire curve was displaced considerably above and approximately parallel to the curve for the air cooled series for each specimen type. The same findings were evident after quenching from 1200°F, with the embrittlement being more pronounced.

Impact specimens water quenched from 1200°F and aged for various periods of time up to two months at room temperature showed no embrittlement "as-quenched"; however, the transition temperature increased with aging time, reaching a maximum level after about two weeks. Accelerated aging at 400°F for one hour immediately after quenching from 1200°F resulted in a marked improvement in impact properties, approaching that of the as-received plate.

No change in microstructure could be noted between the subcritically treated specimens and the as-received plate with these exceptions: (1) a general precipitation was evident after accelerated aging, and (2) slight spheroidization was apparent at the long isothermal times. Rockwell B hardness tests showed that, in general, appreciable hardening occurred when specimens were embrittled.

Previous work on welded plate at this laboratory showed that the necessary conditions for quench-aging are present in the welded material and this phenomenon appears to be the only possible explanation for the zone of minimum ductility

located in a region adjacent to the weld which was not heated above the lower critical temperature. Cooling rate curves are presented for the critical zone in weldments made with various preheat temperatures to show that not only does the embrittlement increase with increasing cooling rate, but that the degree of embrittlement is about the same for the critical zone in weldments as for subcritically heat treated base plate cooled at the same rate from the same temperature.

INTRODUCTION

This report summarizes the work completed on a project sponsored by the Ship Structure Committee under Department of the Navy, Bureau of Ships contract NObs-45470 and under the guidance of the Committee on Ship Steel of the National Academy of Sciences-National Research Council and covers the period from January 1, 1950, to September 1, 1952. Three Technical Progress Reports on commercial ship plate weldments, SSC-24⁽¹⁾, SSC-34⁽²⁾, and SSC-54⁽³⁾ covered the progress of the investigation from July 1, 1947, to January 1, 1950.

In the previous work on the exploration of the relative ductility across weldments of A and C ship plate steels*, it was found that a zone of minimum ductility occurred just outside the so-called heat affected zone in weldments made with 100°F preheat, in a region which appeared to have the same metallographic structure as the base plate. This behavior was evident at both the midthickness and surface levels of 3/4-inch plate. The ductility was evaluated by means of the eccentric notch tensile test, which possessed the advantage of measuring the properties of a very small volume of metal from any position in the weldment.

*The designations A and C refer to steels "A" and "C" in the series of Ship Structure Committee "Project" Steels.

Additional tests revealed that a higher welding preheat (400°F) minimized the embrittlement in the critical zone, while a 1100°F postheat almost eliminated it. The magnitude of the improvement is shown, Table I, in the comparison of the transition temperatures of the unaffected base plate and the critical zone after the various welding conditions.

TABLE I

Transition Temperatures* of Unaffected Base Plate and Zone of Minimum Ductility in A and C Steel Weldments

<u>Location and Welding Conditions</u>	<u>Transition Temperature, °F</u>	
	<u>Steel C</u>	<u>Steel A</u>
Unaffected Base Plate (2" or more from weld centerline)		
100°F preheat and interpass temperature	-65**	-80
400°F " " " "	-65	
1100°F postheat with 100°F preheat.	-75	
Zone of Minimum Ductility (0.3 inch from weld centerline)***		
100°F preheat and interpass temperature	-20	-40
400°F " " " "	-45	
1100°F postheat with 100°F preheat	-70	

*At the midthickness of 3/4-inch plate.

**At the surface level the transition temperature was -60°F.

***At the surface level the zone of minimum ductility was shifted to 0.4 inch from the weld centerline due to the geometry of the double-V weld used.

Temperature measurements made during welding showed that the zone of minimum ductility was not heated above the lower critical temperature; consequently, the embrittlement (and the improvement brought about by preheat and postheat treatments)

occurred at subcritical temperatures, suggesting a quench-aging mechanism resulting from the solution and precipitation of carbides from the alpha phase.

No weld failures have been found to originate in this critical zone. It was felt however, that further work was desirable on the embrittling characteristics of ship plate steel under more closely controlled subcritical conditions than exist in weldments. Specifically, the program consisted of subjecting base plate of "C" steel to temperatures in the 700°--1200°F range for various times, employing three different cooling rates--air cool, furnace cool, and water quench. In addition, an aging study was carried out after water quenching from 1200°F. The embrittlement was evaluated by means of eccentric notch tensile and Charpy V-notch impact transition temperatures, supplemented by hardness tests and microscopic examination.

The present investigation was complicated at the start by embrittlement of test specimens with nitrogen, introduced by a scaling reaction in the nitrate salt bath used as the heating medium. Although interesting, these results are not pertinent to the present investigation and are presented and discussed in a Supplement to this report.

MATERIAL

The "C" steel selected for the present investigation was the same "project steel" which had been used in the earlier work at this laboratory and in other Ship Structure Committee

investigations. It was a semi-killed steel in the form of 3/4-inch material from two large plates from the same heat. The program started with material remaining from the weldment studies, hereafter referred to as Plate I; however, the majority of the work was done with Plate II. The plates have been identified because, as will be shown later, a significant difference in transition temperature was found between plates. The properties reported for this steel are as follows:⁽⁴⁾

TABLE II

Properties of "C" Steel Plate

Chemical Analysis

Carbon	0.24	Copper	0.03
Manganese	0.48	Chromium	0.03
Phosphorous	0.012	Molybdenum	0.005
Sulphur	0.026	Tin	0.003
Silicon	0.05	Nitrogen	0.009
Aluminum	0.016	Vanadium	< 0.02
Nickel	0.02	Arsenic	< 0.01

Mechanical Properties

Yield Point, psi	39,000
Tensile Strength, psi	67,400
Elongation per cent	25.5 (8" Gauge)

PROCEDURE

Specimen Preparation

Notch tensile and standard Charpy V-notch specimens, Fig. 1, were prepared from the plate as follows:

Specimen blanks were taken from the midthickness so that

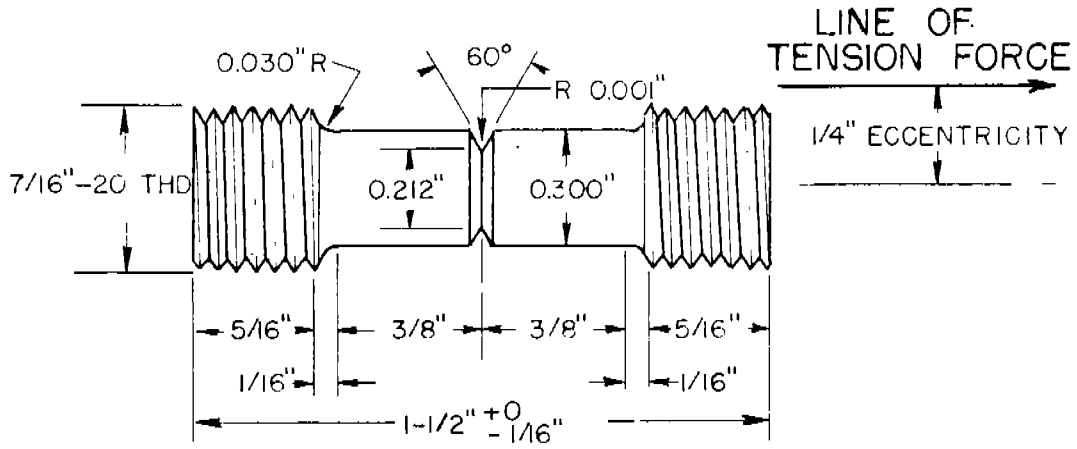

ECCENTRIC NOTCH TENSILE SPECIMEN

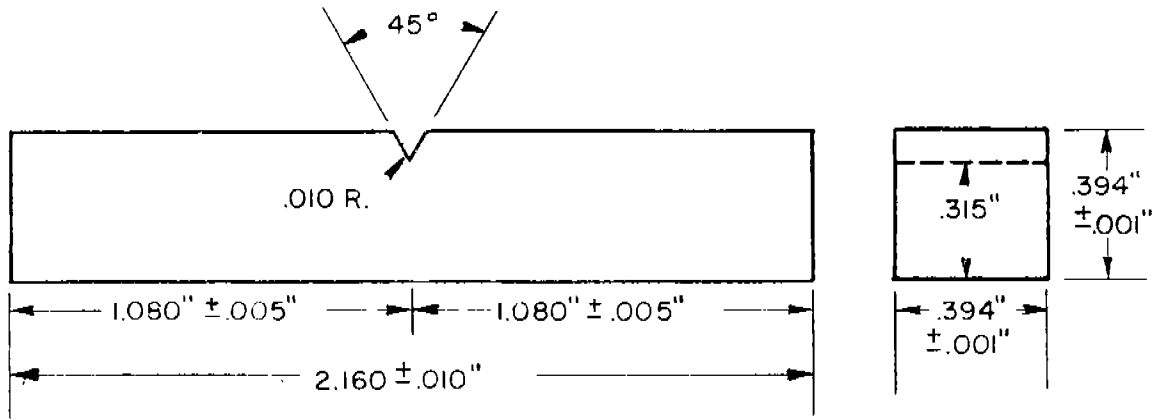

CHARPY V-NOTCH IMPACT SPECIMEN

FIG. 1: TEST SPECIMENS.

the long axis in each case was perpendicular to the rolling direction. The surface of the plate was located by an identifying mark on each specimen. The Charpy blanks were then rough machined 0.020 inch oversize, and the notch tensile blanks 0.015 inch oversize. After heat treating, the blanks were machined to size and notched. The notch for the Charpy specimens was cut perpendicular to the plane of the plate.

The steps involved in the preparation of the test specimens are illustrated in Fig. 2.

Subcritical Heat Treatment

The specimen blanks were heated at a temperature within the 700°--1200°F range for periods of isothermal time ranging from a few seconds at temperature to as long as one week. For times greater than five minutes, a Lindberg forced air convection furnace was used; for times five minutes or less, a neutral chloride salt bath. A chromel-alumel thermocouple at the center of a specimen blank was used to obtain an accurate measure of the time at temperature for the shorter isothermal times*.

Three different cooling rates--air cool, furnace cool**,

*For impact specimens the time required to reach a temperature of 1100°F was 1 1/2 minutes, and to reach 1200°F, 2 1/4 minutes; for notch tensile specimens, the times were 3/4 and 1 minute, respectively.

**Furnace cooled at an average rate of 1.8°F per minute down to 500°F, then air cooled to room temperature.

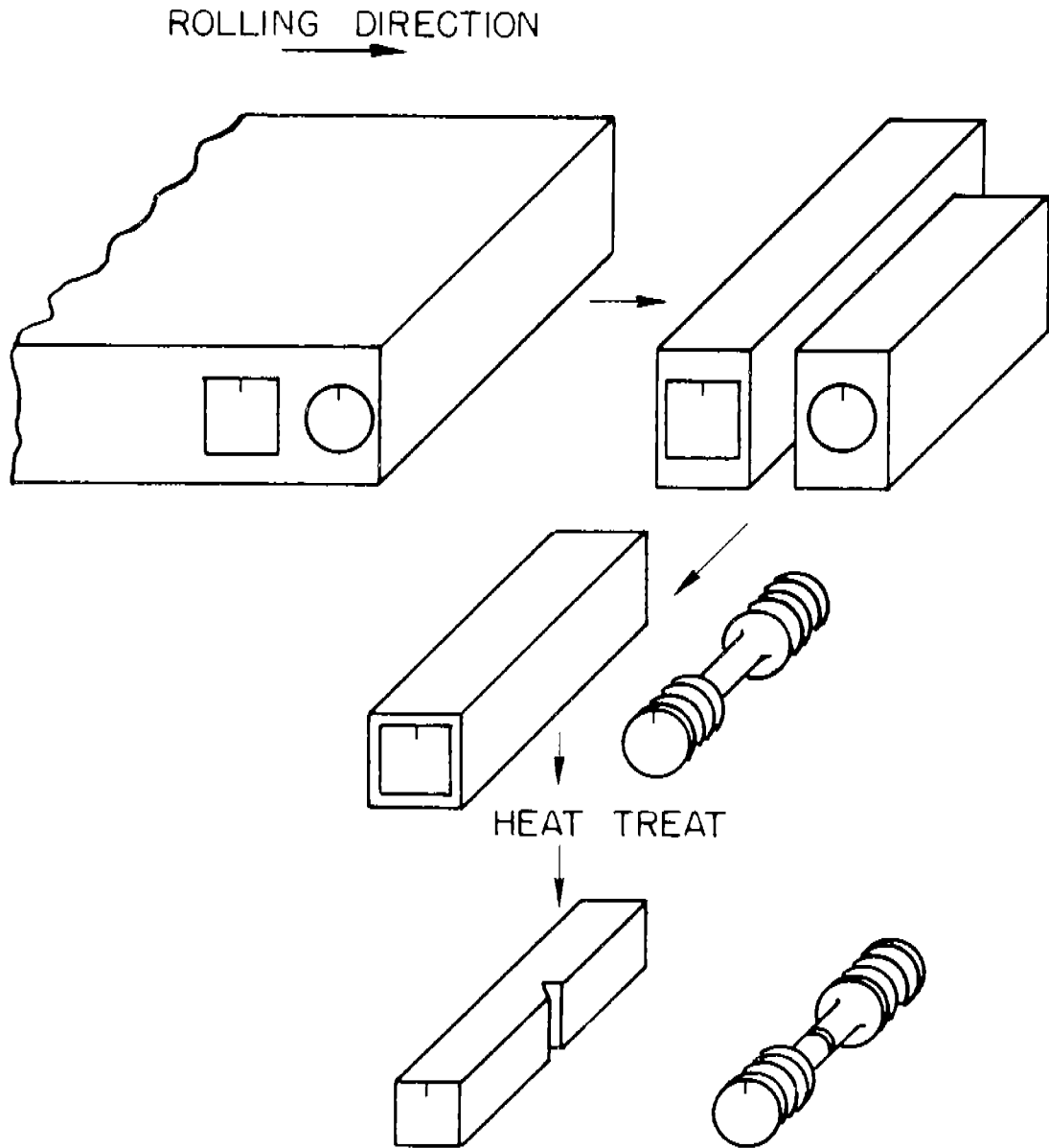

FIG. 2; PREPARATION OF CHARPY V-NOTCH AND NOTCH TENSILE SPECIMENS FROM "C" STEEL PLATE.

water quench--were employed from the subcritical temperatures. Normally, specimens were tested one month after heat treating in order to approximate the elapsed time between welding and testing in the previous work; however, the room temperature aging effects were also evaluated by testing Charpy specimens at different times after water quenching from 1200°F.

The heat treatments employed are given in Table III for notch tensile specimens and in Tables IV and V for impact specimens.

Cooling Curves

The cooling curves for test specimens which were air cooled and also water quenched from 1200°F were determined with a chromel-alumel thermocouple and a portable potentiometer. The couple was positioned in a saw cut extending to the center of a specimen, with the cut then being peened shut. The cooling curve for furnace cooled specimens was obtained by taking temperature-time readings from a furnace controller.

Testing Procedure

The test equipment and procedure for the eccentric notch tensile tests were essentially the same as those used previously (1,2,3). The specimens were positioned in the fixtures, Fig. 3, so that the fiber in line with the identifying mark received the maximum tensile load. The initial eccentricity was set at 1/4 inch, that is, the centerline of the specimen was displaced 1/4 inch from the loading axis of the tensile machine

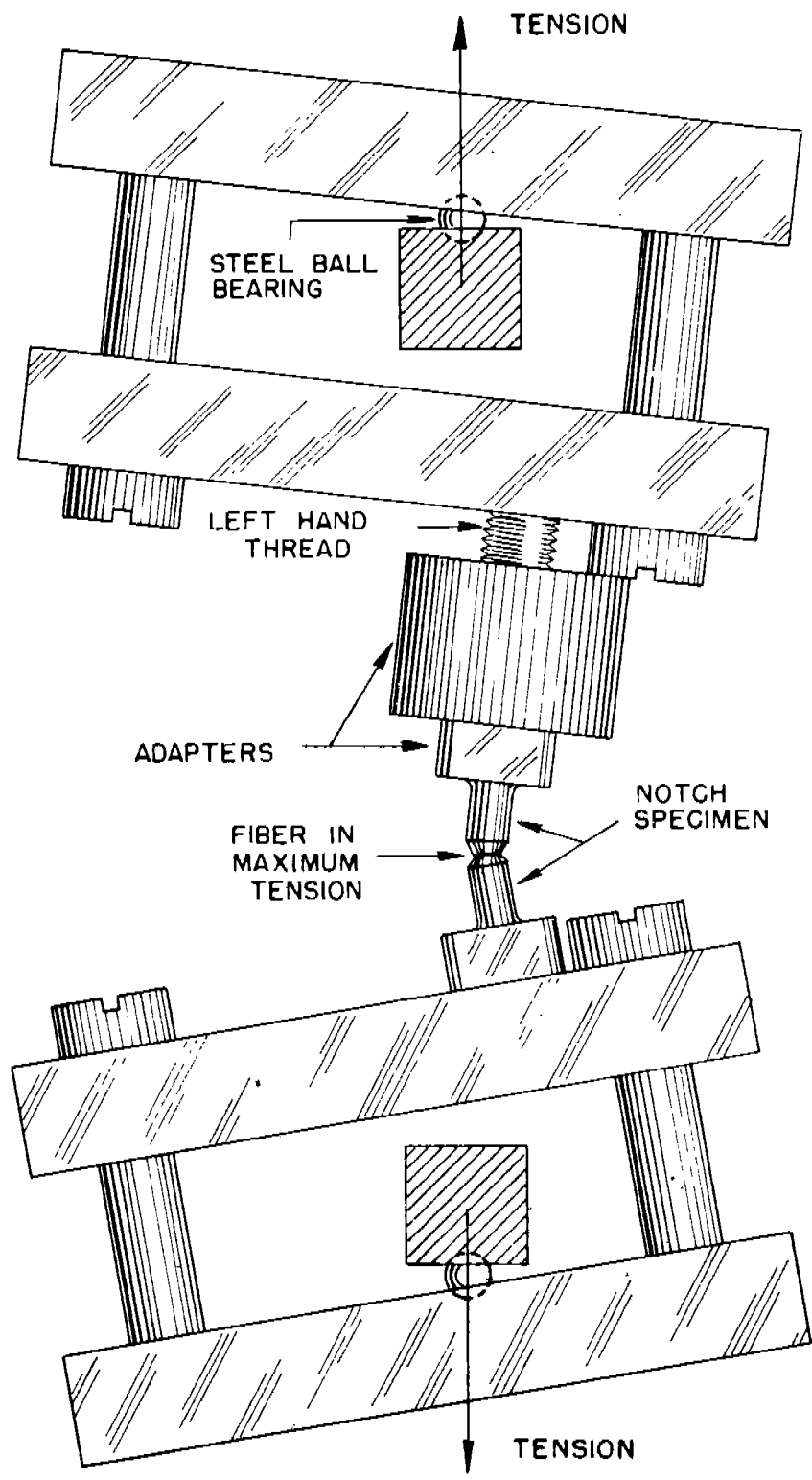

FIG. 3: METHOD OF LOADING TO OBTAIN 1/4 INCH ECCENTRICITY. (ECCENTRICITY AND THE POSITION OF FIXTURES ARE EXAGGERATED.)

as shown in Fig. 3.

In testing below room temperature the specimen was cooled to about 5°F below the desired testing temperature, allowed to warm up to the testing temperature and then tested. In testing above room temperature, the specimen was heated to about 5°F above the desired testing temperature, allowed to cool down and then tested. The tests were performed at constant temperature since the testing time was about 30 seconds, whereas the warming-up or cooling-down rate was about 1°F per minute. The specimens were brought to temperature by means of an appropriate bath of isopentane-dry ice mixture or hot water. Temperatures were measured by a copper-constantan thermocouple wrapped around the specimen. All of the tests were carried out at a low strain rate; the crosshead speed of the tensile machine was approximately 0.1 inch per minute. The property that was measured was the eccentric notch strength, maximum load divided by the original area at the notch bottom.

The impact specimens were cooled or heated in an appropriate bath of isopentane-dry ice or a high temperature oil. As before, a copper-constantan thermocouple was used to measure temperatures. The specimen was held in the bath ten minutes to assure temperature uniformity, and then transferred and tested in a standard impact machine in less than 5 seconds. Both the energy absorbed in fracture and the

per cent fibrous fracture values were obtained.

RESULTS

Transition Temperatures and Hardness

Transition curves obtained from the eccentric notch tensile tests have been assembled in Fig. 1A--8A in Appendix A; and from Charpy V-notch tests, in Figs. 1B--7B in Appendix B. From these curves the transition temperatures were determined using the following criteria:

(A) Eccentric Notch Tensile:

The temperature corresponding to a notch strength midway between maximum and minimum on the average notch strength curve (dashed line in the figures)

See Appendix A.

(B) Charpy V-Notch:

- (1) The temperature at which 15 ft-lbs were absorbed.
- (2) The temperature corresponding to an energy midway between maximum and minimum on the average energy curve.
- (3) The temperature at which the fracture was 50 per cent fibrous.

Transition temperatures determined from the notch tensile tests are summarized in Table III; and from Charpy V-notch tests, in Tables IV and V. Rockwell B hardness values are also given in Tables IV and V.

TABLE III

Subcritical Heat Treatments and Transition Temperatures
(Eccentric Notch Tensile) of "C" Steel

<u>Time at Temperature</u>	<u>Transition Temperature °F</u>	<u>Plate No.</u>
As-Received*	-65	I
As-Received	-40	II
<u>700°F, Air Cool</u>		
10 minutes	-34	II
1 hour	-40	I
8 hours	-32	II
15 hours	-38	I
30 hours	-36	I
1 week	-38	I
<u>800°F, Air Cool</u>		
10 minutes	-44	I
10 minutes	-30	II
1 hour	-40	I
24 hours	-38	I
24 hours	-28	II
1 week	-50	I
1 week	-42	II
<u>950°F, Air Cool</u>		
10 minutes	-42	I
20 minutes	-35	I
1 hour	-38	I
1 hour	-32	II
12 hours	-36	II
1 week	-58	I
1 week	-38	II
1 week	-36	II
<u>1100°F, Air Cool</u>		
5 minutes	-38	II
15 minutes	-30	II
1 hour	-26	II
12 hours	-30	II
112 hours	-48	II
1 week	-50	II

*Previously reported in weldment study⁽¹⁾.

TABLE III (Continued)

<u>Time at Temperature</u>	<u>Transition Temperature °F</u>	<u>Plate No.</u>
<u>1200°F, Air Cool</u>		
5 minutes	-38	II
1 hour	-38	II
10 hours	-36	II
20 hours	-28	II
72 hours	-40	II
<u>1100°F, Water Quench**</u>		
5 minutes	+12	II
1 hour	+6	II
10 hours	+8	II
96 hours	-10	II
<u>1200°F, Water Quench**</u>		
0-10 seconds	+46	II
1/2 minute	+50	II
5 minutes	+68	II
1 hour	+68	II
10 hours	+86	II
72 hours	+74	II

**All water quenched series aged one month at room temperature before testing.

TABLE IV

Subcritical Heat Treatments Transition Temperatures (Charpy V-Notch) and Hardnesses of "C" Steel

<u>Time at Temperature</u>	<u>Transition Temperature °F</u>			
	<u>Midpoint</u>	<u>50% Fibrous Fracture</u>	<u>15 Ft. Lbs.</u>	<u>Rockwell B Hardness</u>
As-Received	118	138	87	74-76
<u>1100°F, Air Cool</u>				
10 minutes	108	142	85	74
1 hour	110	142	85	73
20 hours	115	138	88	71
40 hours	115	145	85	69
72 hours	115	140	92	68
112 hours	125	158	98	67
120 hours	133	152	95	67
<u>1200°F, Air Cool</u>				
1/2 minute	108	135	82	74
1 hour	135	148	92	72
10 hours	133	152	98	69
20 hours	132	155	92	65
72 hours	150	175	110	63
232 hours	168	188	115	60
<u>1100°F, Furnace Cool</u>				
10 minutes	110	145	85	74
120 hours	137	152	102	66
<u>1200°F, Furnace Cool</u>				
1/2 minute	110	135	85	74
<u>1100°F, Water Quench*</u>				
10 minutes	135	148	110	85
1 hour	135	165	116	86
14 hours	152	165	116	86
112 hours	157	168	122	82
1 week	157	180	118	81

*Aged one month at room temperature

NOTE: All results based on Plate II

TABLE IV (Continued)

<u>Time at Temperature</u>	<u>Midpoint</u>	<u>50% Fibrous Fracture</u>	<u>15 Ft. Lbs.</u>	<u>Rockwell B Hardness</u>
<u>1200°F. Water Quench*</u>				
0-10 seconds	110-155	140-195	90-140	77-86
1/2 minute	165	190	146	91
2 minutes	160	190	142	90
10 minutes	158	200	140	89
1 hour	160	198	140	90
5 hours	177	205	148	89
10 hours	178	212	150	88
20 hours	184	210	162	86
72 hours	182	212	158	82

*Aged one month at room temperature

NOTE: All results based on Plate II

TABLE V

Aging Treatments, Transition Temperatures (Charpy V-Notch), and Hardnesses of "C" Steel, Water Quenched from 1200°F.

<u>Isothermal Time at 1200°F</u>	<u>Aging Time at Room Temperature</u>	<u>Midpoint</u>	<u>Transition Temperature, °F</u>		
			<u>50% Fibrous Fracture</u>	<u>15 Ft. Lbs.</u>	<u>Rockwell B Hardness</u>
1/2 minute	As quenched	---	---	---	84
1/2 minute	5 hours	180	150	90	84
1/2 minute	26 hours	---	---	105	84
1/2 minute	3 days	---	---	105	87
1/2 minute	7 days	---	---	130	87
1/2 minute	14 days	---	---	140	89
1/2 minute	30 days	165	190	146	91
1/2 minute	42 days	---	---	154	91
1/2 minute	65 days	---	---	148	91
10 hours	10 days	150	177	125	84
10 hours	30 days	178	212	150	88
20 hours	7 days*	137	165	110	72
20 hours	30 days	182	212	158	82

*Aged at 400°F for one hour immediately after quenching and prior to room temperature aging.

NOTE: All results based on Plate II

In the following sections of the report, the effects of the various subcritical heat treatments are evaluated with A and B(1)* above as the criterion of embrittlement for the notch tensile and the impact test, respectively.

Base Plate

As a check on any variation between the two large plates in the as-received condition, the notch tensile transition behavior was determined for Plate II. The results are shown in Fig. 1A**. In Fig. 4 a comparison of the results with those previously reported⁽¹⁾ for Plate I shows that the distribution of values for Plate II was shifted to higher testing temperatures, the transition temperature being -40°F as compared with -65°F for Plate I. In addition, the upper level of the notch strength values was slightly lower for Plate II, indicating a lower tensile strength. Due to this difference in transition behavior, the results obtained with subcritically heat treated plate have been separated as to plate number.

The transition curve obtained with impact specimens from Plate II is shown in Fig. 1B. No check was necessary because

*The use of either B(2) or B(3) as the criterion of embrittlement for the impact tests would reveal the same general effects as B(1).

**The letter following the figure number refers to the corresponding Appendix.

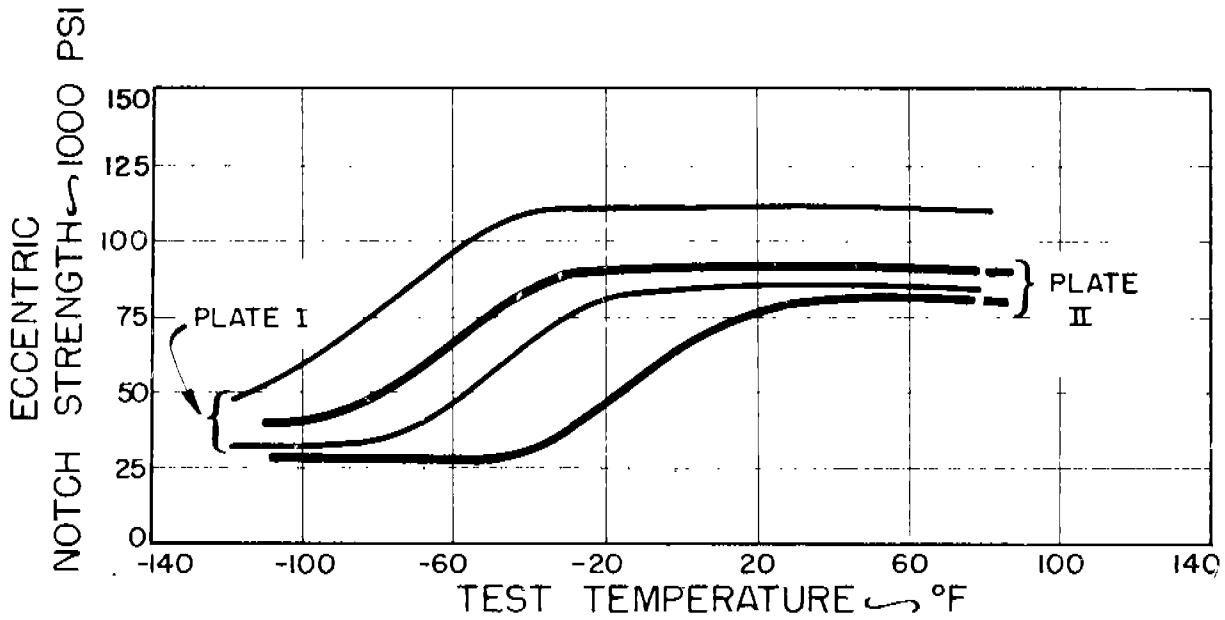

FIG. 4: COMPARISON OF ECCENTRIC NOTCH TENSILE TRANSITION BEHAVIOR FOR TWO DIFFERENT PLATES OF AS-RECEIVED "C" STEEL.

this plate supplied all of the impact specimens for this investigation.

Air Cooled

The individual transition curves for the various sub-critical heat treatments employing an air cool are shown in Figs. 2A--6A for notch tensile tests, and in Figs. 2B and 3B for impact tests.

The relationship between notch tensile transition temperature and time at various temperatures is plotted in Fig. 5. For each of the five temperatures investigated--700°, 800°, 950°, 1100°, and 1200°F--there is a slight embrittlement at the shorter times. With increasing time at 700°F, the transition temperature appears to be unchanged, at least up to times of one week. At each of the higher temperatures, the transition temperature remains constant with time after the initial embrittlement and then approaches, or drops below the base plate value at longer times.

It should be noted that at 700°, 800°, and 950°F both Plates I and II were used and yielded transition temperature-time curves which were similar, but with the highest transition temperature of Plate I (-40°F) being about 10°F lower than Plate II (-30°F) over the time interval considered. This is in agreement with the base plate values which showed that Plate I had a lower transition temperature.

With the as-received plate as a basis of comparison, it

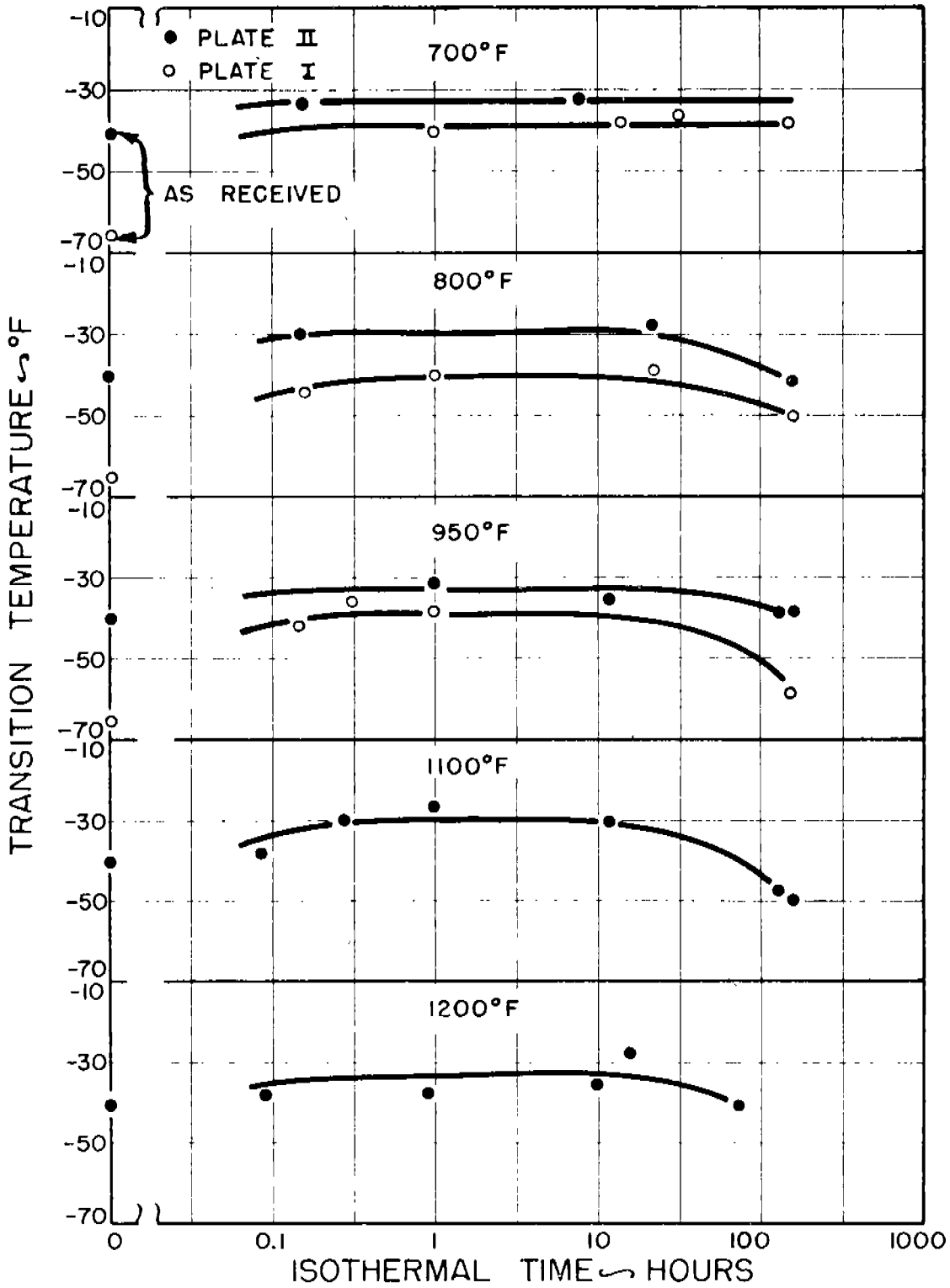

FIG. 5: ECCENTRIC NOTCH TENSILE TRANSITION TEMPERATURES OF "C" STEEL AS A FUNCTION OF TIME AT VARIOUS SUBCRITICAL TEMPERATURES. AIR COOLED.

is seen that the maximum embrittlement amounted to a 10°F increase in transition temperature for Plate II, and a 25°F increase for Plate I.

An examination of the individual notch tensile transition curves in Figs. 2A--4A reveals that, although the slope and the amount of scatter in the transition range are about the same for the two plates, the upper level of notch strength for Plate I is consistently higher (about 10,000 psi) than Plate II. Again, this is in agreement with the findings for the as-received base plate and denotes a slightly higher tensile strength for Plate I.

In Fig. 6, the transition temperature-isothermal time relationship is shown for impact specimens heated at 1100°F and 1200°F. The transition temperature remains essentially the same as the as-received plate until, after about ten hours at 1200°F and 72 hours at 1100°F, the transition temperature slowly increases with the 1200°F curve showing a somewhat faster rate of increase. It should be noted, however, that the upper level of energy absorbed slowly increases not only with time at temperature but also with temperature, thus indicating an improvement in impact properties at the higher testing temperatures. This improvement is not reflected in the transition temperature using any of the three criteria employed.

From the hardness values listed in Table IV, it is

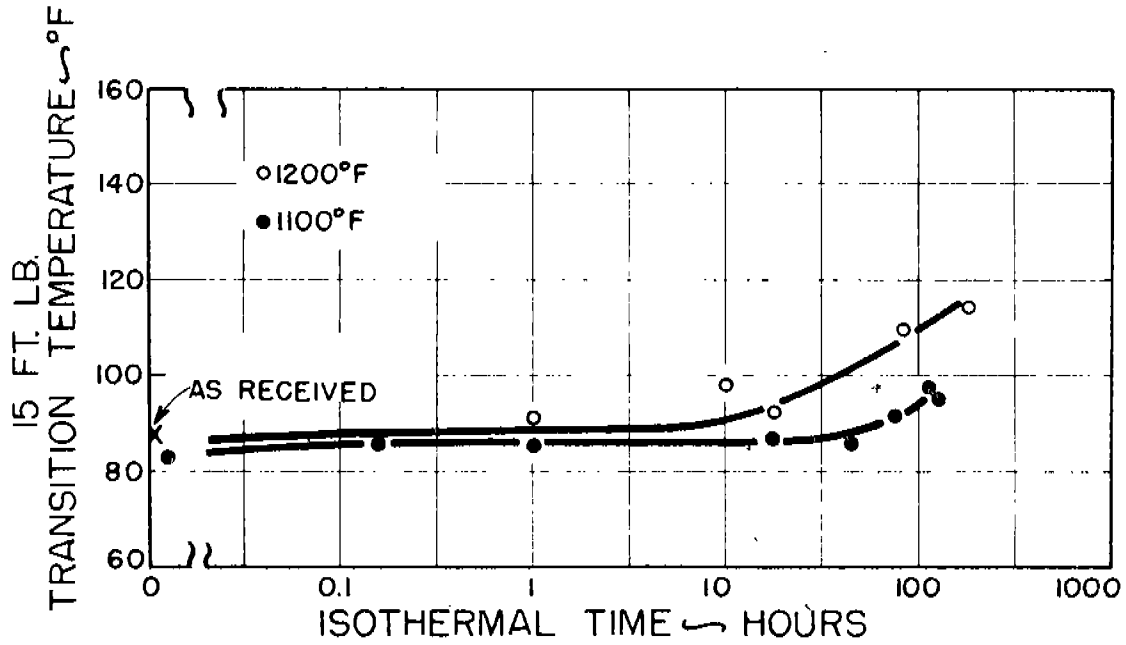

FIG. 6: CHARPY V-NOTCH TRANSITION TEMPERATURE AS A FUNCTION OF TIME AT SUBCRITICAL TEMPERATURES. AIR COOLED. PLATE II.

apparent that with increasing time at 1100°F there is a gradual softening; at 1200°F, the decrease in hardness with time is even more pronounced. As will be shown later this is an exception to the increased hardness usually associated with increased Charpy transition temperature.

A comparison of the notch tensile and impact results for the 1100°F and 1200°F heat treatments points out two interesting differences: (1) At the shorter times, a slight embrittlement is evident with notch tensile but not with impact specimens. (2) The transition temperature then remains constant with time, until at the longer times, softening sets in and the notch tensile transition temperature decreases as contrasted to the impact transition temperature which increases.

Furnace Cooled

In order to investigate the effect of a slower cooling rate, three spot checks were made with impact specimens furnace cooled at the rate of 1.8°F per minute after: (1) 10 minutes at 1100°F, (2) 120 hours at 1100°F, and (3) 1/2 minute at 1200°F. The transition curves for these treatments are shown in Figs. 4B and 5B. For each of these three cases there was no significant difference in transition temperature or hardness from specimens heat treated and air cooled. On the basis of these results, it would appear that furnace cooled impact specimens should exhibit the same behavior as the air cooled specimens over the ranges of time and temperature under study.

Water Quenched

The notch tensile transition curves for the various water quenched series are assembled in Figs. 7A and 8A and the impact transition curves in Figs. 6B and 7B. All results are based on Plate II.

Aged One Month at Room Temperature

In order to maintain approximately the same aging interval as previously used in the weldment studies*, both notch tensile and impact specimens were aged one month at room temperature after water quenching.

The transition temperature-isothermal time curves for notch tensile specimens quenched from 1100°F and 1200°F are shown in Fig. 7. For the 1100°F series, the transition temperature is raised to +10°F at the shorter times, amounting to an increase of 50°F above that of the as-received plate. With increasing time, the transition temperature remains at this level and then decreases slightly at the longer times. This general shape of the curve is in agreement with the 1100°F air cooled series.

For the 1200°F series, the entire curve is displaced to still higher transition temperatures. The transition temperature is about +45°F at times less than five minutes, rising

*In the work with weldments, about one month elapsed between the time of welding and testing.

to a maximum of about +85°F after 10 hours and then decreasing slightly at 72 hours. Thus, the transition temperature has been raised from 85° to 125°F above that of the as-received plate. Again, the general trend of the curve is in agreement with the corresponding air cooled series.

It should be noted that two points were obtained at 0 to 10 seconds and 1/2 minute at temperature, respectively, in order to investigate times at temperature which would approximate those actually existing in weldments. The transition curves for these times, Fig. 8A (a and b) show a somewhat greater scatter band than those for the longer times. At isothermal times greater than 1/2 minute, the high values of the scatter band have been lowered, which, in effect, raises the transition temperature.

In comparing the individual transition curves, the water quenched series treated at both 1100° and 1200°F evidenced a higher upper level than the comparably heat treated and air cooled series. This indicates that water quenching served to increase the tensile strength.

The transition temperature-isothermal time relationship for impact specimens quenched from 1100°F and 1200°F are also shown in Fig. 7. The same general shape of curve is evident for both the 1100°F and 1200°F water quenched series as for the comparable air cooled series, i.e., a constant transition temperature with isothermal time, increasing slightly at

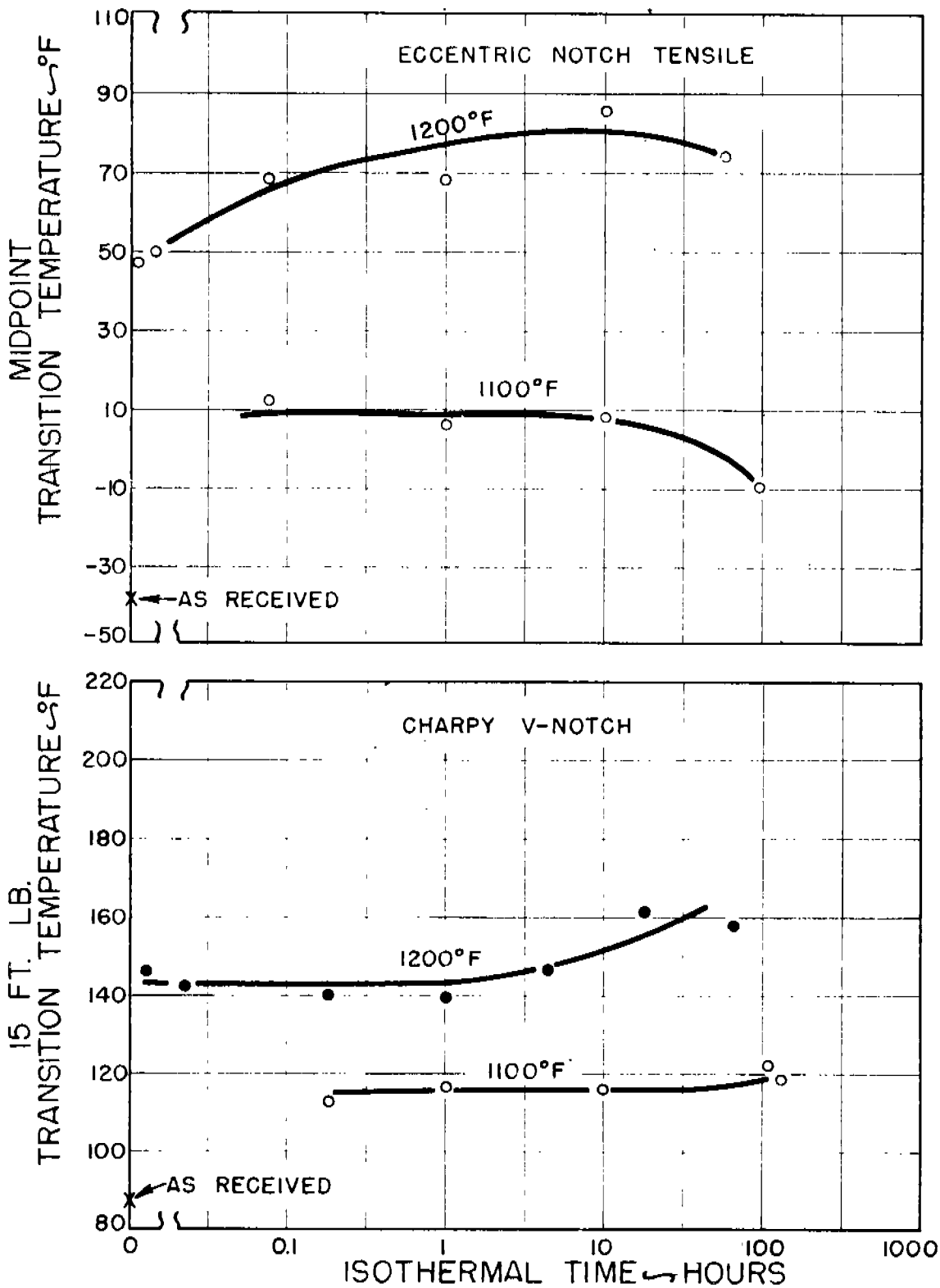

FIG. 7: TRANSITION TEMPERATURES OF "C" STEEL AS A FUNCTION OF TIME AT SUBCRITICAL TEMPERATURES. WATER QUENCHED AND AGED ONE MONTH AT ROOM TEMPERATURE. PLATE II.

longer times and with the 1200°F curve showing a slightly faster rate of increase. A comparison with the air cooled series shows that the quench-aging treatment served to embrittle the steel at all isothermal times, as noted by the displacement of both the 1100° and 1200°F curves to higher transition temperatures and with the embrittlement being of a higher magnitude for the 1200°F heat treatment. The 1100°F water quenched curve is displaced about 25°F and the 1200°F water quenched curve about 55°F above their respective air cooled series (which at the shorter times was the same as the as-received plate.)

For the 1200°F heat treatment, a series of specimens tested for isothermal time of 0 to 10 seconds, Fig. 7B (a) showed considerable scatter in the test results. The minimum and maximum transition temperatures to be expected are given in Table IV; however, this point is omitted in the transition temperature-isothermal time plot because of the apparent difficulty of reproducing structures from specimen to specimen at such short solution times.

An examination of the individual impact transition curves, Figs. 7B and 8B, reveals that for the shorter times at 1100°F and 1200°F the maximum energy level is about 7 ft-lb less than the as-received plate. With increasing time, the upper level is gradually raised above that of the as-received plate with the 1200°F series showing a slightly faster rate of increase.

As noted previously, this effect of time and temperature on the upper level was also evident in the air cooled series.

A review of the hardness values in Table IV shows that for the 1100°F series, the hardness, after an initial increase of ten points Rockwell B, gradually decreases at the longer times. The 1200°F series shows a similar trend except that the initial embrittlement amounted to a hardness increase of 15 points. It is interesting to note that the hardness and transition temperature do not parallel one another with increasing isothermal time. Although both indicate an initial embrittlement, the impact transition temperature increases at long isothermal times; whereas the hardness decreases. This behavior at long isothermal times was also evident in the air cooled series.

Room Temperature Aging Study

In order to check the room temperature aging effects, impact specimens were tested after treating at 1200°F for 1/2 minute and aging at room temperature for times ranging from five hours to 65 days. The transition temperatures and hardness values are summarized in Table V, while the individual transition curves are shown in Fig. 7B (b--j).

In Fig. 8 the energy transition curves for aging times of five hours and 30 days are compared with the as-received⁴⁹ plate. It can be seen that for five hours' aging time, the

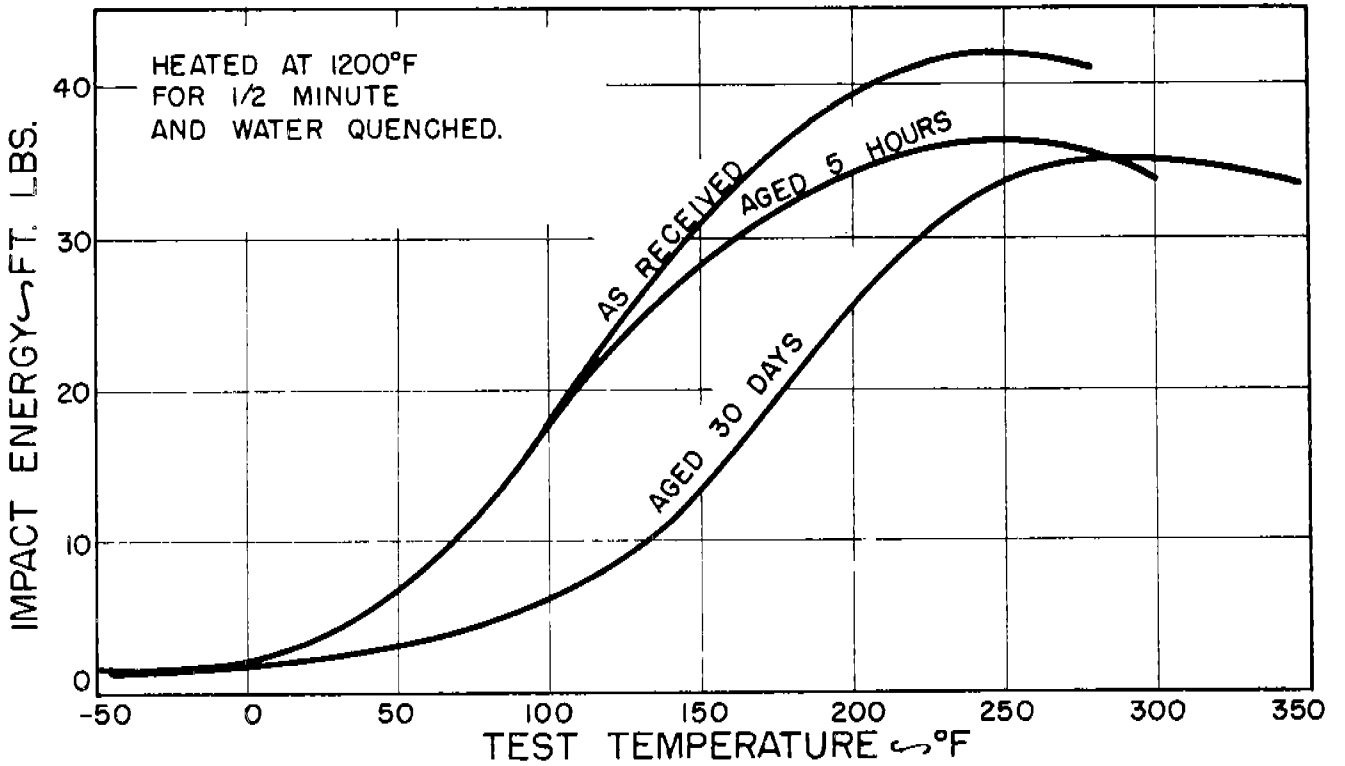

FIG. 8: EFFECT OF ROOM TEMPERATURE AGING TIME ON CHARPY V-NOTCH TRANSITION CURVES OF "C" STEEL.

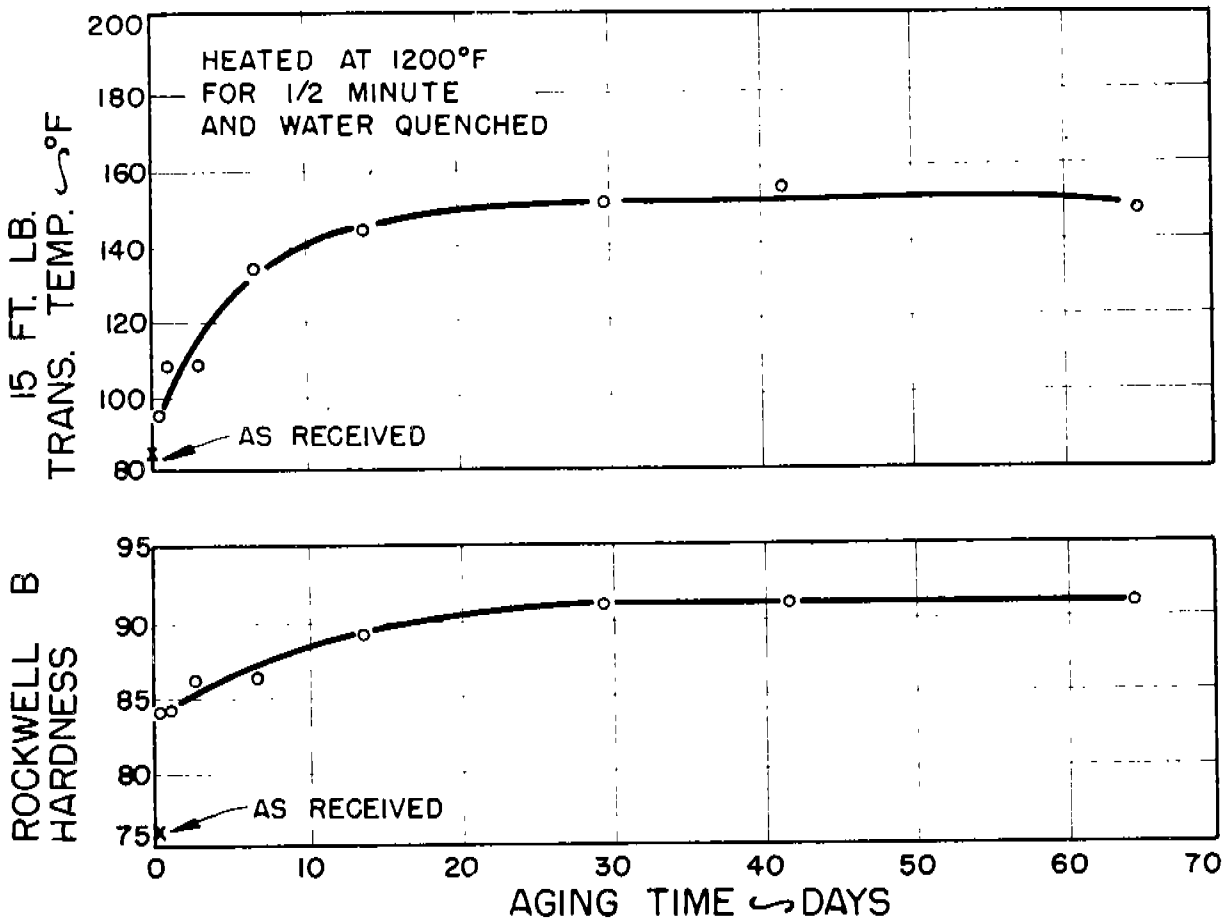

FIG. 9: EFFECT OF ROOM TEMPERATURE AGING TIME ON THE CHARPY V-NOTCH TRANSITION TEMPERATURE AND HARDNESS OF "C" STEEL.

energy values at the lower testing temperatures are about the same as the as-received plate but lower at the higher testing temperatures--the upper level being decreased from 42 to 36 ft-lb. For 30 days' aging time, the entire energy curve is shifted to higher testing temperatures. This shift amounts to about a 60°F increase in 15 ft-lb transition temperature.

To obtain a measure of the rate of embrittlement, additional impact data were obtained for intermediate and longer aging times. Complete transition curves were not obtained, but a rough indication of the 15 ft-lb transition temperature was found from spot tests at temperatures which would contain the 15 ft-lb value. The best straight line was then drawn through the points and the 15 ft-lb value taken. These additional results, along with the hardness values, are plotted as a function of aging time in Fig. 9. Both the transition temperature and hardness show a fairly rapid increase in the aging time interval up to about two weeks, then leveling off. From these results, it can be expected that all the water quenched series which were aged one month at room temperature experienced the maximum embrittlement by room temperature aging.

A check of the aging effect after heat treating at another time (10 hours) at 1200°F was made with two series of specimens aged 10 days and 30 days, respectively. The energy transition curves are compared with that for the

as-received plate in Fig. 10. From this figure, the dependence of the degree of embrittlement on room temperature aging time is again evident.

Accelerated Aging

In establishing the impact energy transition curves, it was necessary to test above room temperature--at times as high as 350°F. As a check on accelerated aging in the testing bath, hardness measurements were made on the series of specimens water quenched after heating for one-half minute at 1200°F and aged at room temperature for five hours and for 30 days. The Rockwell B hardness values before heating in the testing bath and immediately after breaking, are given in Table VI.

The series of specimens aged for five hours indicates that the hardness does not change more than one point from the as-quenched hardness of R_B 84-85 after ten minutes in the testing bath at temperatures up to 300°F; however, those specimens aged for 30 days show that the hardness is progressively decreased from R_B 91 to R_B 83 in the temperature interval from 175°--350°F. The latter series of tests indicates that accelerated aging, as measured by hardness tests, can take place in the testing bath at temperatures above 175°F in ten minutes. However, the effects of sub-critical heat treatment on the transition temperature would

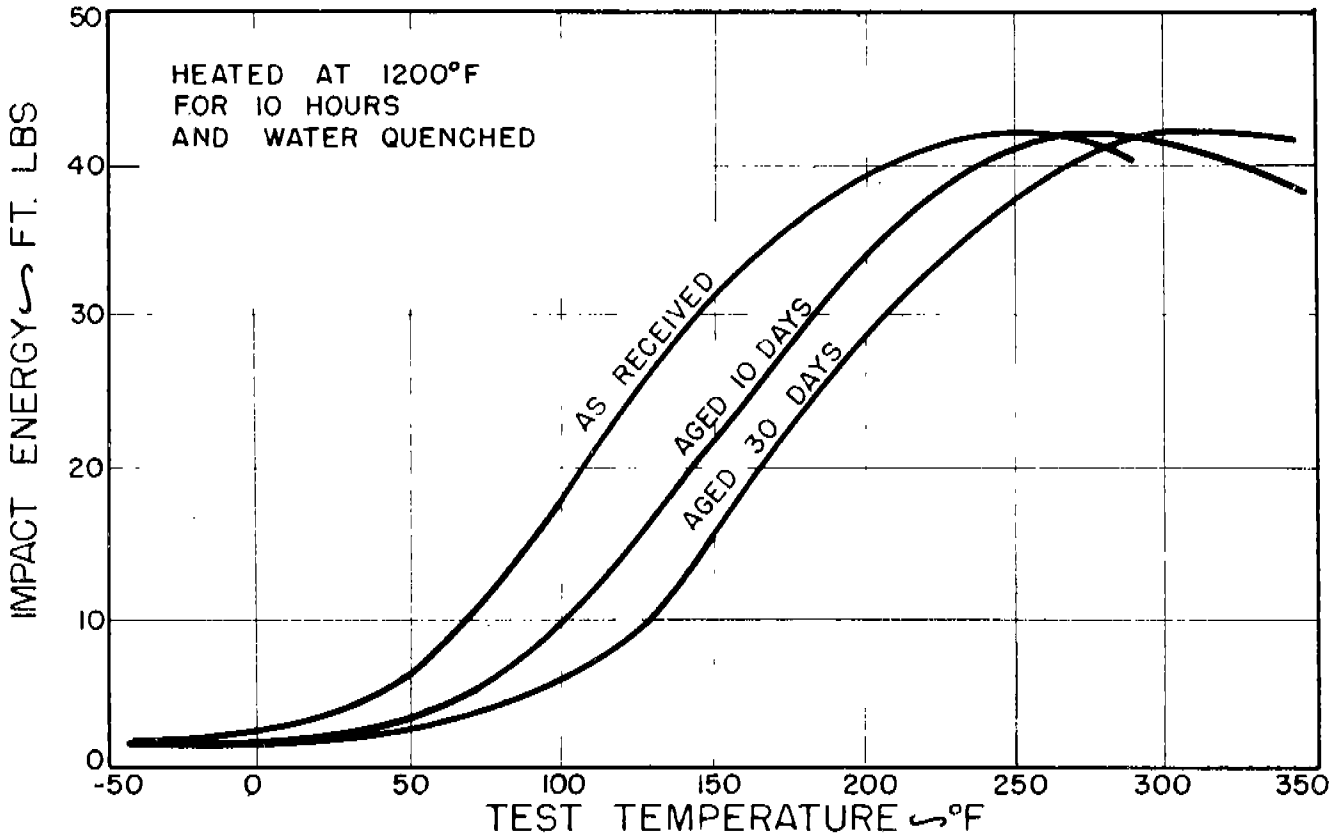

FIG. 10: EFFECT OF ROOM TEMPERATURE AGING TIME ON CHARPY V-NOTCH TRANSITION CURVES OF "C" STEEL.

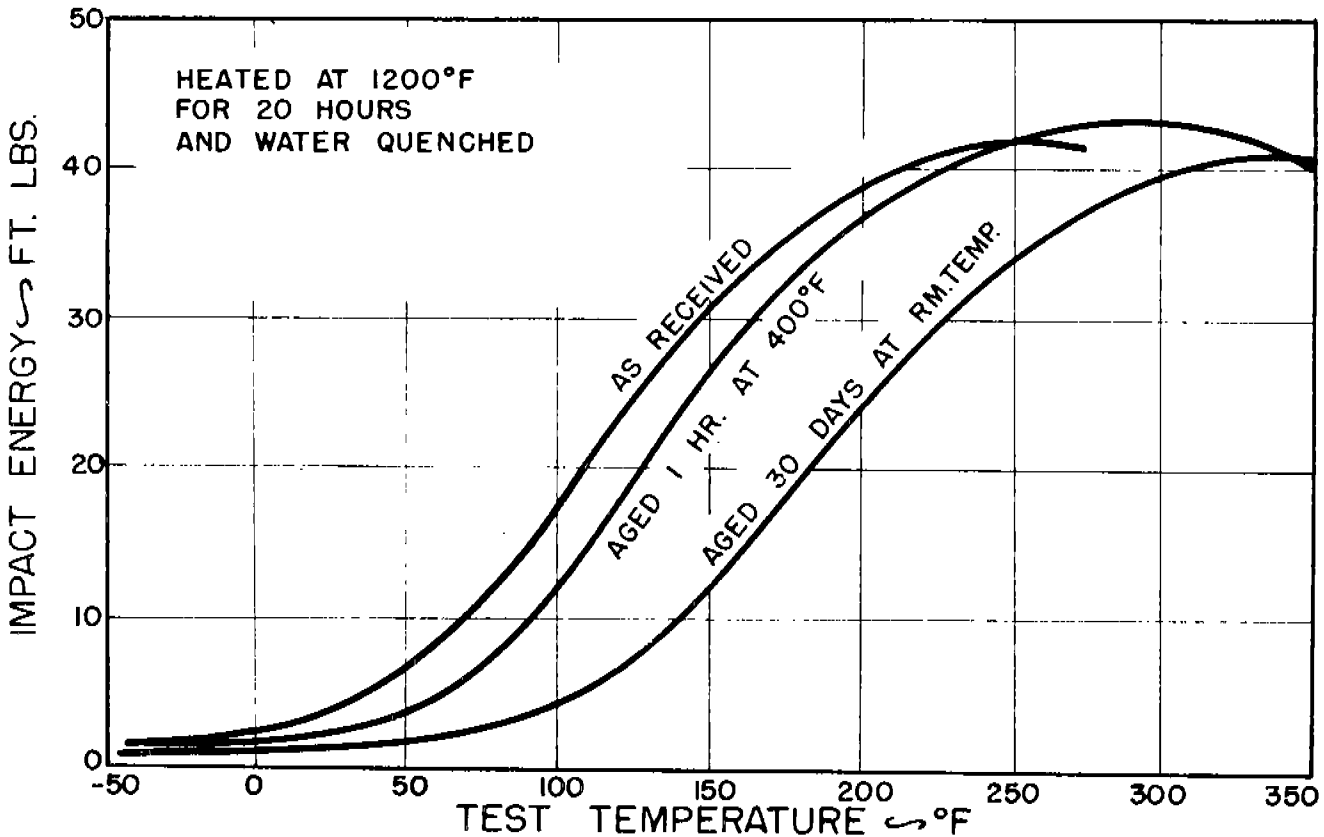

FIG. 11: COMPARISON OF CHARPY V-NOTCH TRANSITION CURVES FOR ROOM TEMPERATURE AND ACCELERATED AGING OF "C" STEEL.

appear to be unaffected in view of the fact that the temperature at the 15 ft-lb energy value was taken as the transition temperature, and in all series this temperature was less than 175°F.

TABLE VI

Hardness Check on Accelerated Aging of Charpy Specimens in Testing Bath

<u>Subcritical Heat Treatment</u>	<u>Test Temperature, °F</u>	<u>Rockwell B Hardness</u>		
		<u>Before Heating</u>	<u>After Breaking</u>	
Heated at 1200°F for 1/2 minute and water quenched.	301	84	84	
	272	85	86	
	204	85	86	
	Aged 5 hours at room temperature before placing in test bath.	173	84	84
		140	84	84
		115	85	85
	82 (RT)	84	84	
Heated at 1200°F for 1/2 minute and water quenched.	348	91	83	
	325	92	86	
	298	91	85	
	Aged 1 month at room temperature before placing in test bath.	275	92	85
		250	91	88
		225	92	88
		202	91	89
		174	91	92
		125	91	92
		100	91	91
	82 (RT)	91	91	

A spot check on the effect of accelerated aging on the transition temperature was made by heat treating a series of impact specimens at 1200°F for 20 hours, water quenching, and then immediately aging at 400°F for one hour. The resulting energy transition curve is compared, Fig. 11, with a comparably heat treated series naturally aged at room temperature for one month. The pronounced improvement brought about by the

accelerated aging treatment is at once evident in the shift of the entire curve to lower testing temperatures, approaching that of the base plate. The transition temperature of the accelerated aged plate was only slightly higher than the series treated at 1200°F for 20 hours and air cooled. Hardness checks on broken specimens showed no change with time, indicating that this accelerated aging treatment resulted in virtually complete stability. Further work on the effects of accelerated aging on the transition temperature is now under way. The general program to be followed is outlined in the section on Future Work.

Microstructures

An examination of the microstructures was made of the base plate and after all conditions of heat treatment to afford a possible explanation of the transition behavior. Representative photomicrographs at 2000X are shown in Fig. 12.

The microstructure for the as-received condition, Fig. 12(a), showed the same structure for both Plates I and II. No apparent explanation can be given to account for the superior properties of Plate I, other than a difference in composition or rolling practice which is not evident in the microstructure.

The photomicrographs in Figs. 12(b) and 12(c) were made after heat treating at 1200°F for 1/2 minute and



(a) As-Received
*TT = +87°F



(b) 1200°F, 1/2 minute
Furnace Cooled,
TT = +85°F



(c) 1200°F, 1/2 minute, water
quenched and aged one
month at room temperature,
TT = +146°F



(d) 1200°F, 72 hours, furnace
cooled, not tested

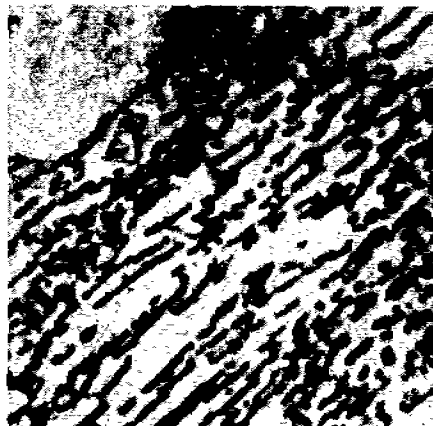

(e) 1200°F, 72 hours, water
quenched and aged one
month at room temp.
TT = +138°F



(f) 1200°F, 20 hours, water
quenched. Aged one hour
at 400°F, TT = +110°F

Fig. 12: MICROSTRUCTURES OF "C" STEEL IN THE AS-RECEIVED CONDITION AND AFTER VARIOUS SUBCRITICAL HEAT TREATMENTS.

*Charpy 15 ft-lb Transition Temperature.

employing a furnace cool and a water quench, respectively. No difference in structure from that of the as-received plate could be noted for either of these two heat treatments. At long isothermal times at 1200°F, spheroidization starts to set in, as noted in the furnace cooled structure in Fig. 12(d) and the water quenched structure in Fig. 12(e); however, no difference between these latter two microstructures could be seen due to the difference in cooling rate.

In Fig. 12(f), the microstructure is shown for the water quenched series heat treated at 1200°F for 20 hours followed by accelerated aging at 400°F for one hour. It appears that this accelerated aging treatment has resulted in a general precipitation throughout the ferrite grains, and as the transition temperature and hardness checks showed, was accompanied by a considerable improvement in impact properties and a pronounced decrease in hardness.

Cooling Curves

The cooling curves for the various cooling rates employed from 1200°F are given in Fig. 13 and compared with the cooling history for the first weld pass at the region of low ductility for the two welding conditions under study previously^(1,2). It can be seen that although the 100°F preheat weldment has a faster cooling rate than the 400°F preheat weldment, the cooling rate for both these welding conditions is intermediate to the air cooled and water

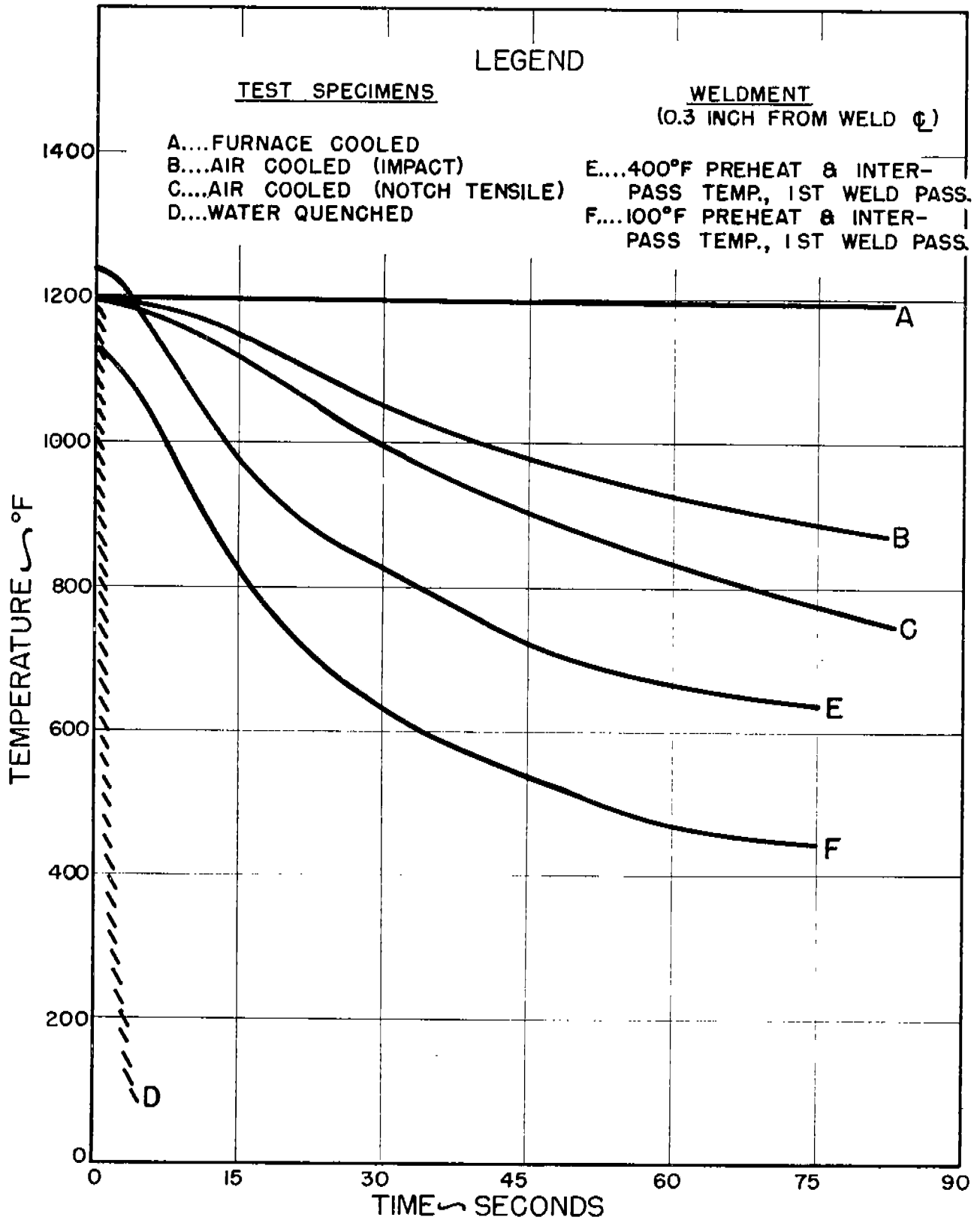

FIG. 13: COMPARISON OF COOLING CURVES IN THE REGION OF LOWEST DUCTILITY FOR TWO WELDING CONDITIONS WITH THOSE OBTAINED WITH HEAT TREATED TEST SPECIMENS.

quenched specimens. Also, it should be noted that with an air cool, the impact specimens cool at a slightly slower rate than the notch tensile specimens due to the larger mass of metal.

DISCUSSION

Previous investigations^(5,6) have shown there are two factors which increase the tensile strength and hardness and lower the ductility of low carbon steel when it is cooled from subcritical temperatures, namely, the solid solution and the aging effects. The solution effect is the formation of a supersaturated solution of carbon in ferrite and has the maximum effect after fast quenching. The second factor, aging, is the precipitation of carbides from the supersaturated solution which has the maximum effect at some critical point of time and temperature, beyond which the effect is decreased.

The results of the work to date can be discussed in terms of the combined solid solution and aging phenomenon, commonly referred to as "quench-aging".

Considering the air cooled series first, the notch tensile test detected a slight embrittlement after heat treating in the 700°--1200°F range, as contrasted to the impact test which indicated no change in properties after treatment at 1100°F and 1200°F at the shorter times. From

these results it can be reasoned that precipitation occurred largely during cooling and no appreciable change in properties was realized on subsequent aging. The slight embrittlement revealed by notch tensile tests could be attributed to a slight solution and subsequent aging effect due to the slightly faster rate of cooling with notch tensile specimens. At the longer isothermal times, softening set in which resulted in a divergence in transition behavior between the two specimen types, i.e., the notch tensile transition temperature decreased while the impact transition temperature increased. At the same time, however, the energy absorbed by Charpy specimens at the higher testing temperatures was increased. The eccentric notch tensile transition and Charpy energy behavior at longer isothermal times might be expected as a result of the slightly spheroidized structure. The reasons for these differences in behavior evidenced by spheroidized structures are not completely understood. It is believed that this occurrence is not the result of any solution or aging effects, but is due to different reactions of the two types of specimens to a slightly spheroidized structure.

With a decrease in cooling rate--furnace cool--the spot checks with impact specimens showed that the transition temperature and hardness were unchanged from the

comparably heat treated and air cooled series. Although no notch tensile tests were conducted with furnace cooled specimens, it is believed that this slower cooling rate will result in no embrittlement because it is to be expected that the solid solution and aging effects will then be nil.

A consideration of the notch tensile and impact results obtained by water quenching reveals a pronounced embrittlement which is influenced by the following:

1. Isothermal time
2. Subcritical temperature
3. Aging time
4. Aging temperature.

The isothermal time at a particular temperature must be long enough to allow the complete solution of the soluble phase (carbon). With incomplete solution, the lower is the degree of supersaturation, and, consequently, the slower is the rate and amount of precipitation, resulting in smaller changes in properties as shown by the tests after heat treating at 1200°F for short times. The divergent behavior between the two specimen types at long isothermal times can again be attributed to the spheroidization effect mentioned above.

If time at temperature is long enough to permit complete solution, the solubility increases with increasing temperature. The degree of supersaturation correspondingly

increases on fast quenching, exerting a more pronounced effect on the properties after subsequent aging. Evidence of this was obtained in the series water quenched from 1200°F and aged one month at room temperature which showed a higher transition temperature and hardness than specimens similarly treated at 1100°F.

The aging study carried out at 1200°F with impact specimens indicated that although the solution effect served to harden the steel, the impact properties for the series aged at room temperature for five hours were about the same as the as-received plate. It can be reasoned then that no significant precipitation occurred in this short aging time; however, an increase in aging time was accompanied by an increase in transition temperature and hardness indicating precipitation from the super-saturated solid solution.

Aging at a higher temperature (400°F) after water quenching from 1200°F effected a large improvement in the impact properties and a pronounced decrease in hardness. This occurrence can be attributed to "overaging", i.e., the aging effect was carried past the critical point of time and temperature.

Although all these factors have pronounced effects on transition temperature and hardness, no visible effect is apparent in the microstructure with the exception

of the overaged series. Here, a general precipitation is evident in the ferrite grains, Fig. 12(f). It can be speculated that in all the other water quenched series the precipitate was retained coherent with the matrix and of such a size so as not to be microscopically visible. Upon exceeding a critical time and temperature, as in the accelerated aged series, the precipitate broke free of the matrix and grew in size so as to be visible.

A review of the work on weldments shows that the necessary conditions for quench-aging are present and appear to be the only possible explanation for the zone of minimum ductility located outside the so-called heat-affected area, i.e., in a region which was not heated above the lower critical temperature at any time.

From Table I it can be seen that maximum embrittlement (45°F increase in notch tensile transition temperature) occurred in a weldment made with 100°F preheat. With a 400°F preheat, the embrittlement amounted to a 20°F increase in transition temperature. In comparison, the air cooled series of subcritically heat treated specimens showed an increase of 25°F in notch tensile transition temperature for the same plate (Plate I) and a 10°F increase for Plate II. From these results, it would appear that the cooling rate for the 100°F preheat weldment is somewhat greater than that obtained by air cooling notch tensile specimens, while for the 400°F preheat weldment the cooling rate is about the same. Confirmation of this is seen in

the cooling curves in Fig. 13. Only the cooling history of the first weld pass of the six-pass weld is shown at the zone of minimum ductility for the two weldments. Considering each weldment separately, subsequent passes resulted in a lowering of the peak temperature reached at the critical zone and a decrease in the cooling rate, Fig. 14. It can be expected that each weld pass would contribute to the solid solution and aging effects, but it is believed that the maximum temperature reached, time at this temperature, and the subsequent cooling rate of the first few weld passes govern the amount of carbon initially retained in solution, while the following passes serve mainly as short accelerated aging treatments.

The almost complete elimination of the critical region by a postheat treatment at 1100°F (see Table I) could be attributed to overaging.

Due to the complexity of the time, temperature and cooling rate factors in a multiple pass weld--factors which have been shown to be interrelated in the quench-aging mechanism--it is not possible to make more than this general comparison with the present investigation.

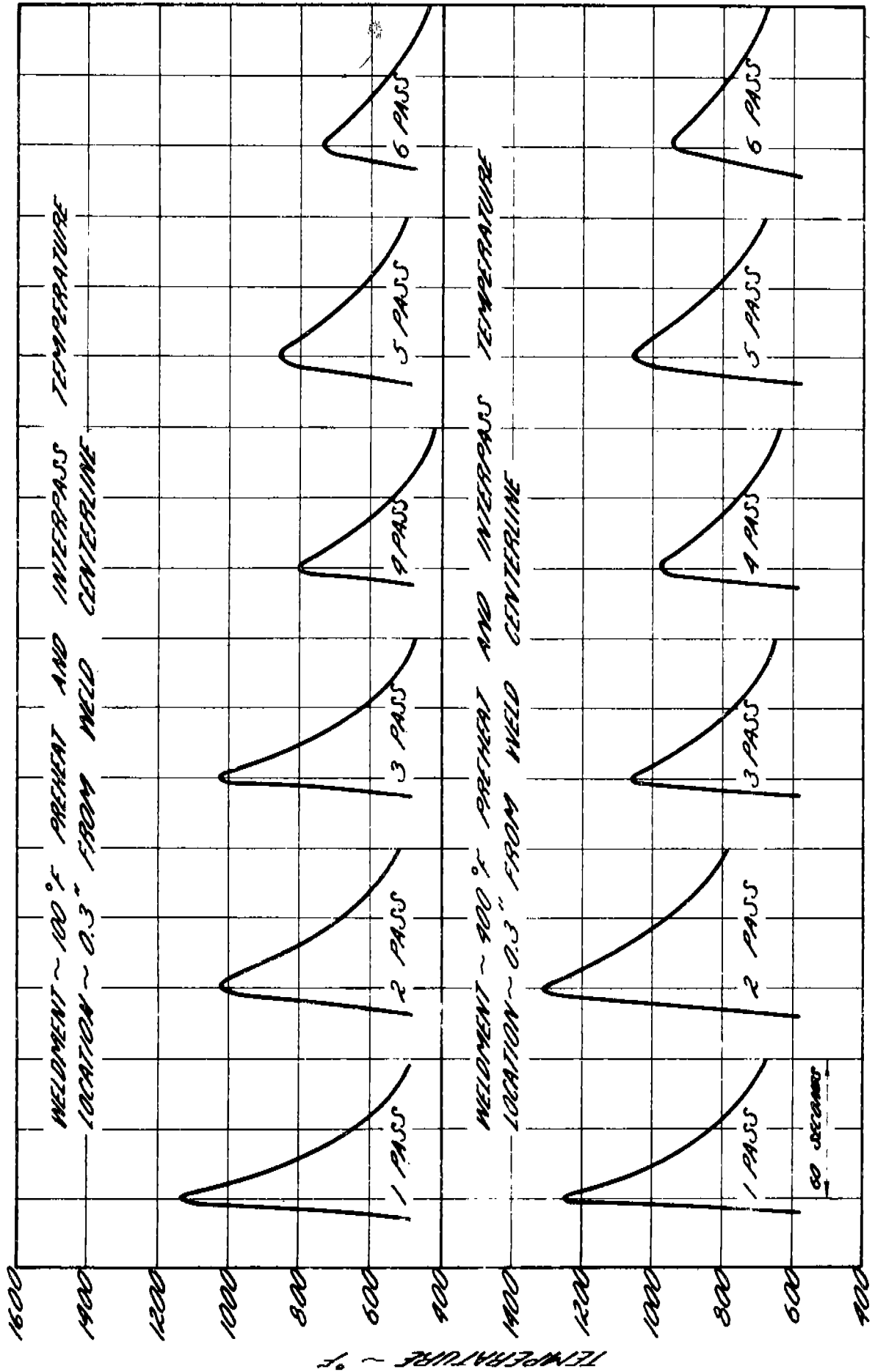

FIG. 19. HEATING AND COOLING CURVES IN THE REGION OF LOWEST DUCTILITY FOR TWO 6 PASS WELDMENTS.

CONCLUSIONS

The quench aging mechanism appears responsible for the loss in ductility and the increase in hardness of a low carbon ship plate steel when subcritically heat treated. The severity of the embrittlement increased with increase in (1) solution temperature, (2) severity of quench, and (3) aging time at room temperature. Direct evidence of precipitation was obtained in the microstructure of an 'overaged' specimen (Figure 12f). Isothermal time at temperature had relatively little effect on the properties other than a softening due to spheroidization.

The results of this investigation appear to confirm the earlier supposition that the quench-aging phenomenon was responsible for the zone of maximum embrittlement being located outside the so-called heat affected zone in ship plate weldments.

FUTURE WORK

To determine the maximum effects involved in the quench-aging phenomenon, it is planned to supersaturate "C" steel to the maximum, i.e., water quench from 1300°F (just below the lower critical temperature), and age for various periods of time at room temperature and at selected elevated temperatures. The change in properties will be followed by impact and hardness tests, supplemented by microscopic examination. It is hoped that this work will also suggest possible methods for eliminating the quench-aging effects responsible for the embrittlement of steel when welded.

ACKNOWLEDGMENTS

The authors wish to acknowledge the aid of Messrs. C. A. Beiser and D. J. Garibotti in performing the tests and also for their many helpful suggestions.

BIBLIOGRAPHY

1. G. Sachs, L. J. Ebert, and A. W. Dana, "The Fundamental Factors Influencing the Behavior of Welded Structures Under Conditions of Multiaxial Stress and Variations of Temperature, Stress Concentration and Rates of Strain", First Progress Report, Ship Structure Committee, Serial No. SSC-24, May 10, 1949.
2. L. J. Klingler, L. J. Ebert, and W. M. Baldwin, Jr., "The Fundamental Factors Influencing the Behavior of Welded Structures Under Conditions of Multiaxial Stress and Variations of Temperature, Stress Concentration and Rates of Strain", Second Progress Report, Ship Structure Committee, Serial No. SSC-34, November 28, 1949.
3. L. J. Klingler and E. B. Evans, "The Fundamental Factors Influencing the Behavior of Welded Structures under Conditions of Multiaxial Stress, and Variations of Temperature", Third Progress Report, Ship Structure Committee, Serial No. SSC-54, October 14, 1952.
4. Technical Progress Report of the Ship Structure Committee, The Welding Journal, Research Supplement, Vol. 13 (July 1948), pp. 377s-384s.
5. G. Sachs, L. J. Ebert, G. B. Kasik, and J. F. Nejedlik, "Fundamentals of Annealing Low Carbon Steel", Part I, Iron and Steel Engineer, Vol. 23 (November 1946), pp. 88-98.
6. R. D. Pollard, "Metallurgical Aspects of Annealing", J. Iron and Steel Inst., Part I, Vol. 162 (May 1949), pp. 79-85.

APPENDIX A
ECCENTRIC NOTCH TENSILE TRANSITION CURVES
and
METHOD OF DETERMINATION OF ECCENTRIC
NOTCH TENSILE TRANSITION TEMPERATURE

Method of Determination of Eccentric
Notch Tensile Transition Temperatures

In establishing the change from ductile to brittle behavior with the eccentric notch tensile test, 30 specimens or more were used for each series. As can be seen from the test data in Figs. 1A to 8A, considerable scatter occurred in the ductile-brittle transition zone, whereas at higher or lower testing temperatures the results were more uniform. For each series the majority of the tests (about 20) were conducted at temperatures within the transition range. A scatter band was obtained by drawing an upper and a lower limiting curve (solid lines in the figures) which contained all the test points. These limiting curves were constructed parallel to each other deviating only at the "knee" and the "toe" of the curves. An average notch strength curve (dashed lines in the figures) was then drawn parallel to the limiting curves, and bisecting the horizontal distance in the transition range. The transition temperature was taken as the temperature at the vertical midpoint of the average notch strength curve.

The average notch strength curve was also determined by averaging the notch strength values at each test temperature for each series and fitting the best curve through these points. Using the midpoint criterion, the resulting transition temperatures agreed very well with those obtained by the method outlined above.

See also pages 9 and 13 and Figures 10 and 11 of Ref. 1.

ECCENTRIC NOTCH TENSILE TRANSITION CURVE OF AS-RECEIVED "C" STEEL. PLATE II.

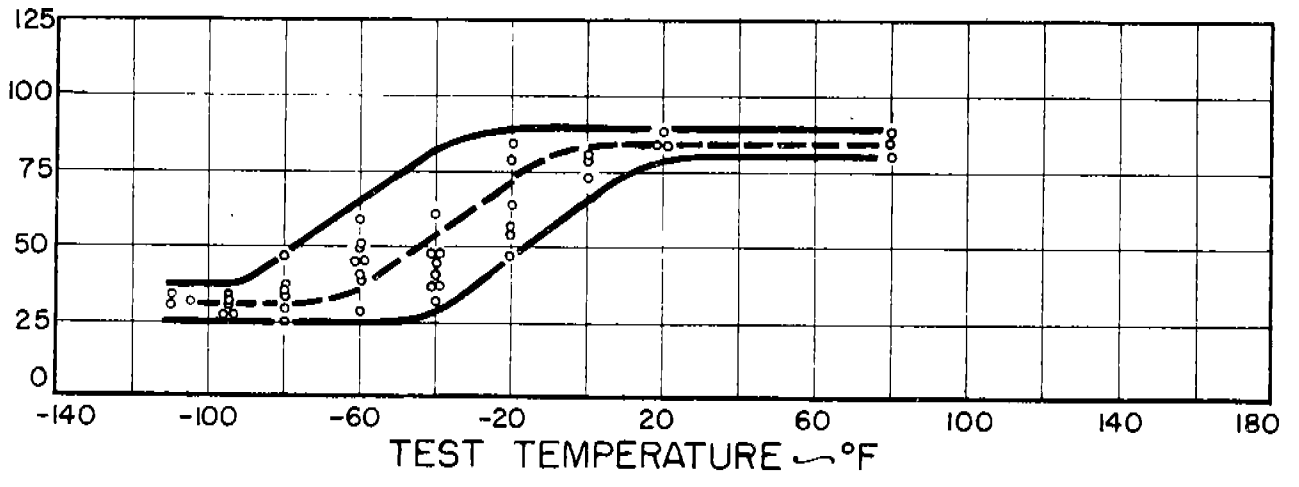

FIG. IA: ECCENTRIC NOTCH TENSILE TRANSITION CURVE OF AS-RECEIVED "C" STEEL. PLATE II.

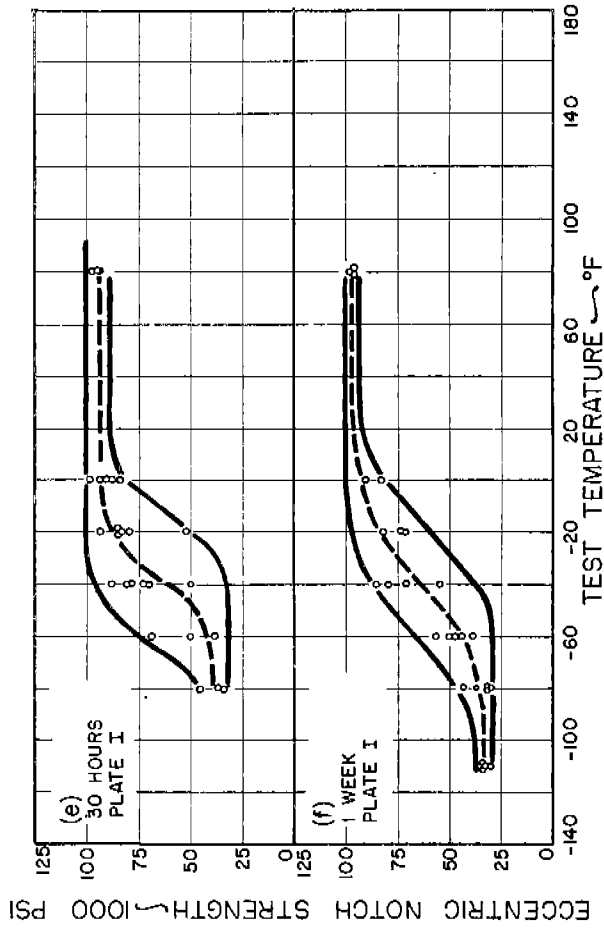
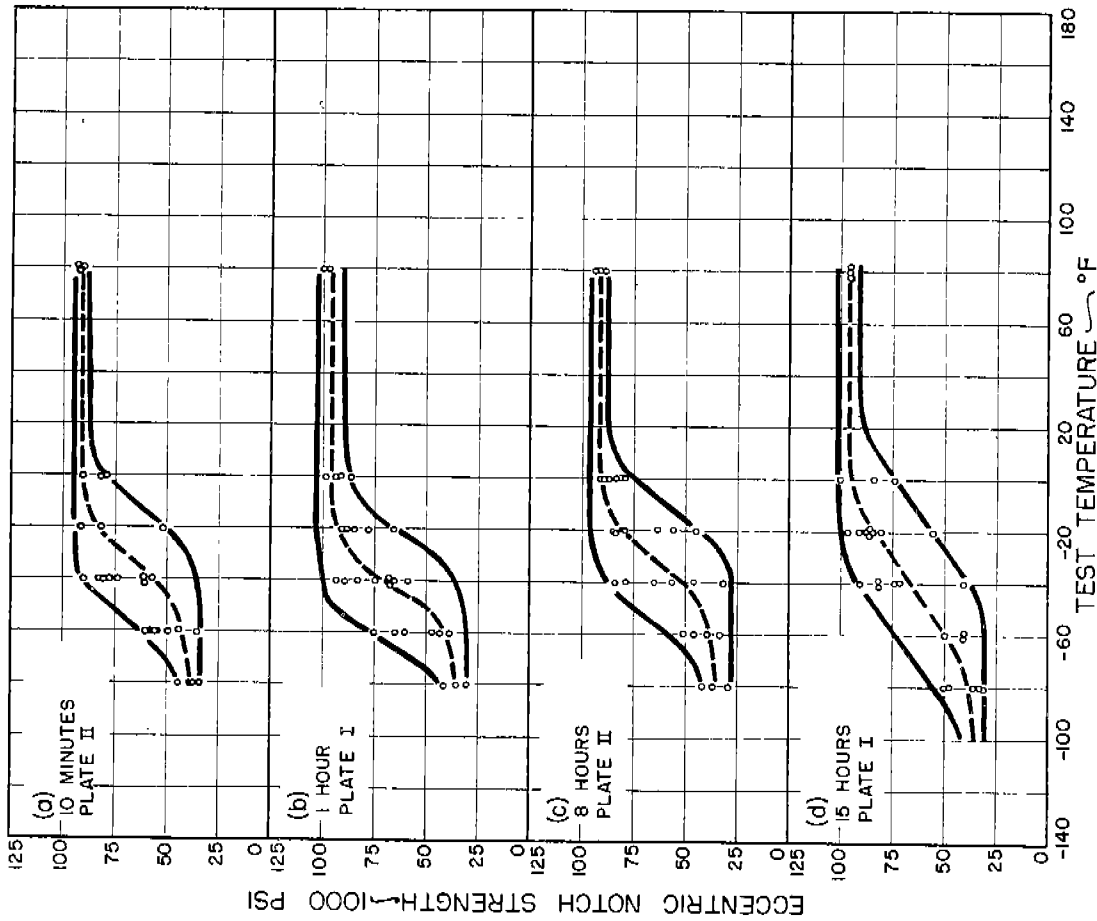

FIG. 2A (CONT.)

FIG. 2A(g-f): ECCENTRIC NOTCH TENSILE TRANSITION CURVES OF "C" STEEL, SUBCRITICALLY HEATED AT 700°F FOR TIMES INDICATED AND AIR COOLED.

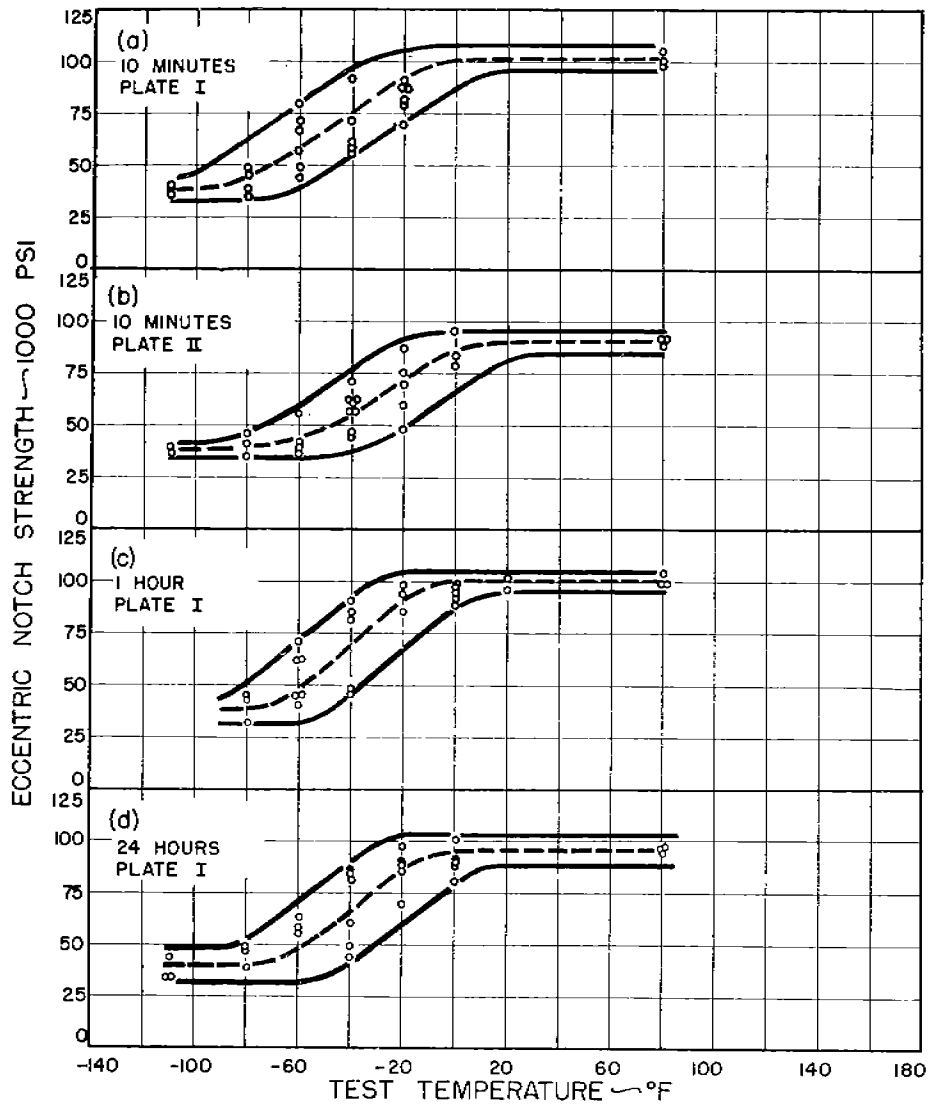

FIG. 3A(a-g): ECCENTRIC NOTCH TENSILE TRANSITION CURVES OF $\frac{1}{2}$ C STEEL. SUBCRITICALLY HEATED AT 800°F FOR TIMES INDICATED AND AIR COOLED.

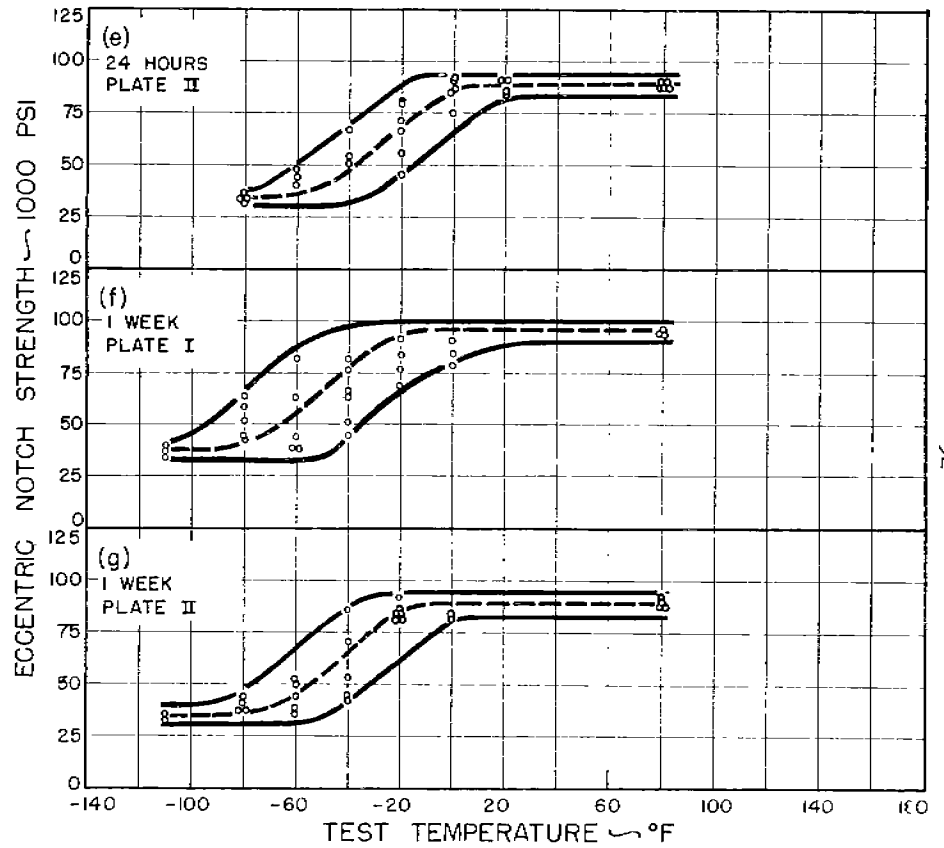

FIG. 3A (CONT.)

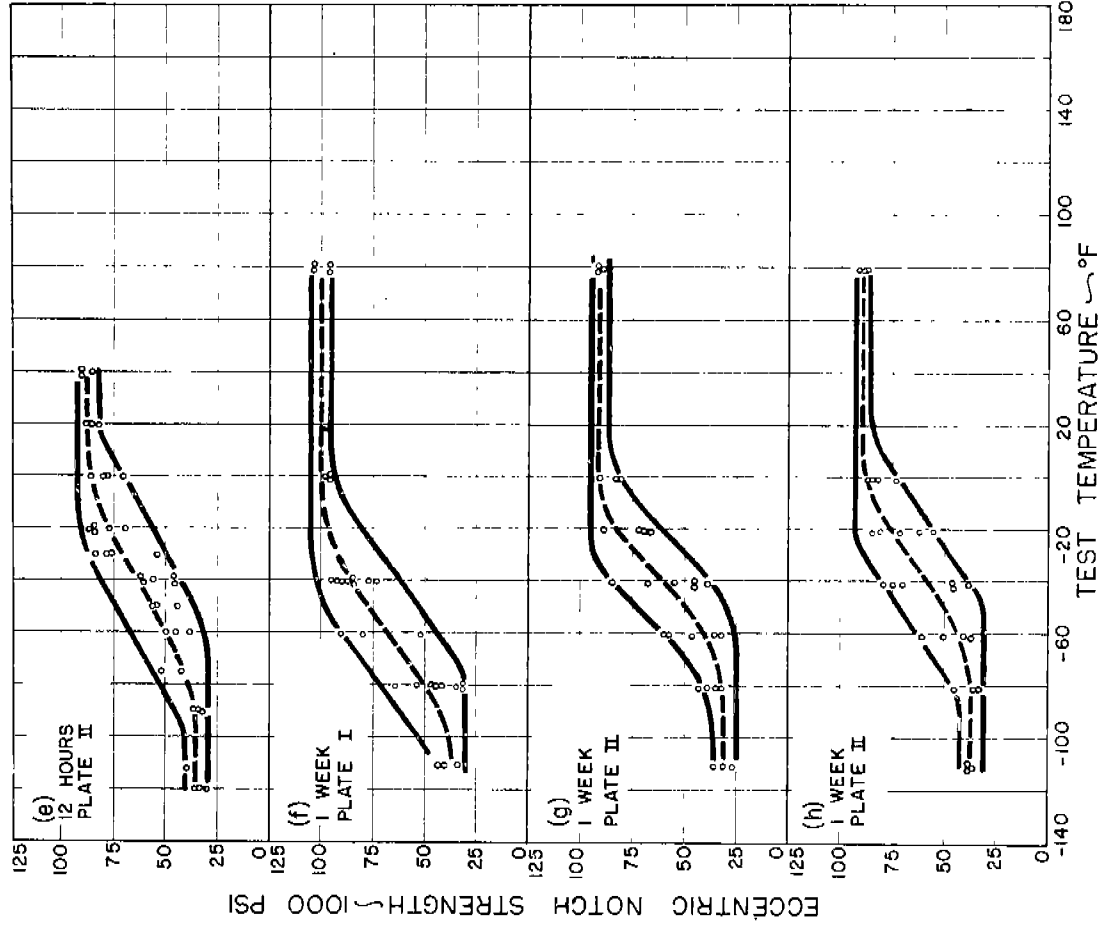

FIG. 4A (CONT.)

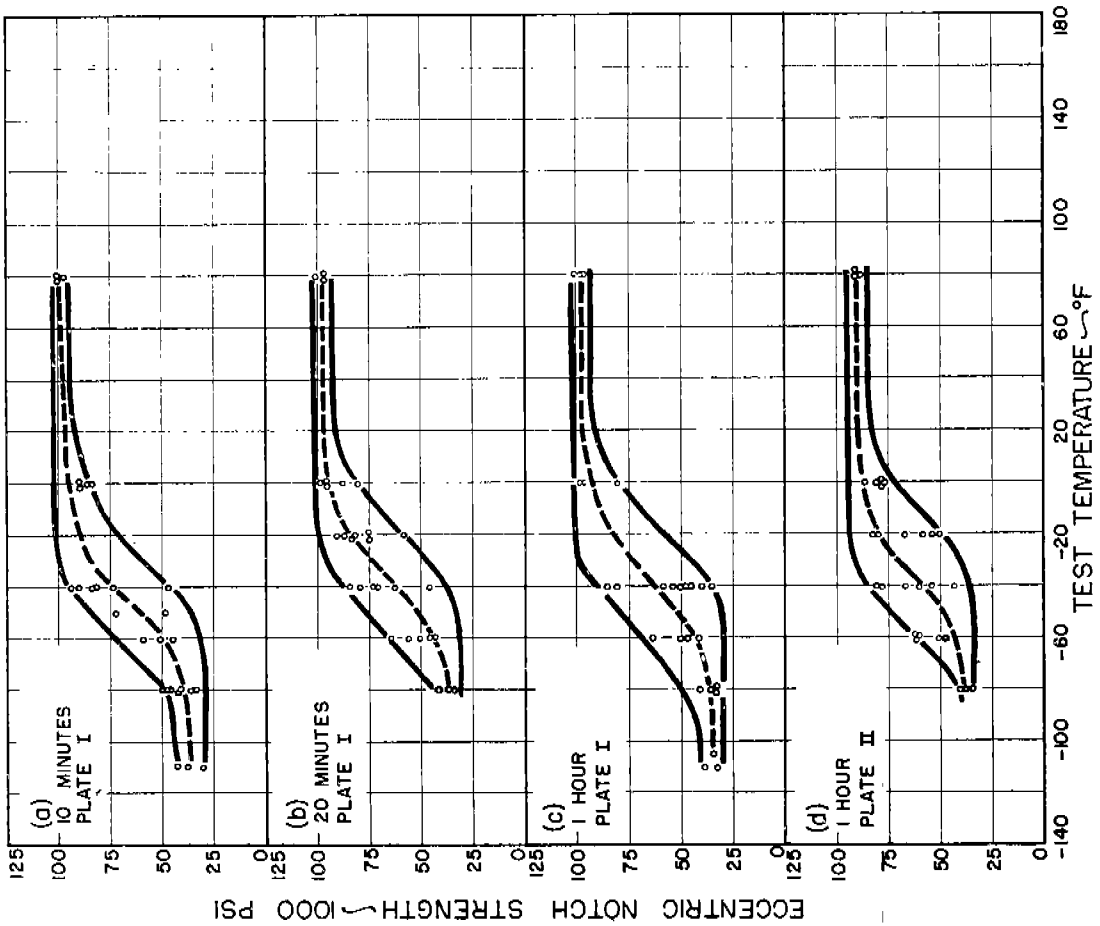

FIG. 4A(a-h): ECCENTRIC NOTCH TENSILE TRANSITION CURVES FOR "C" STEEL, SUBCRITICALLY HEATED AT 950°F FOR TIMES INDICATED AND AIR COOLED.

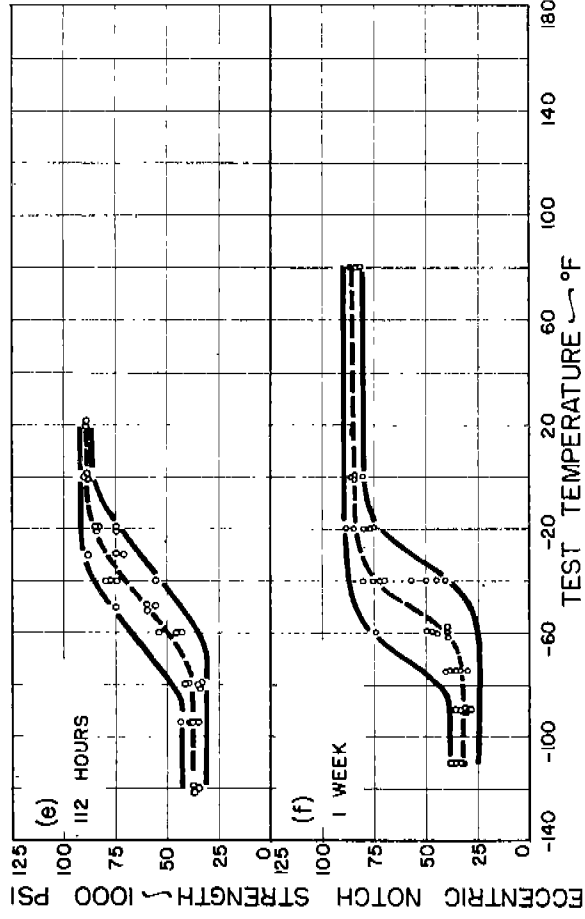
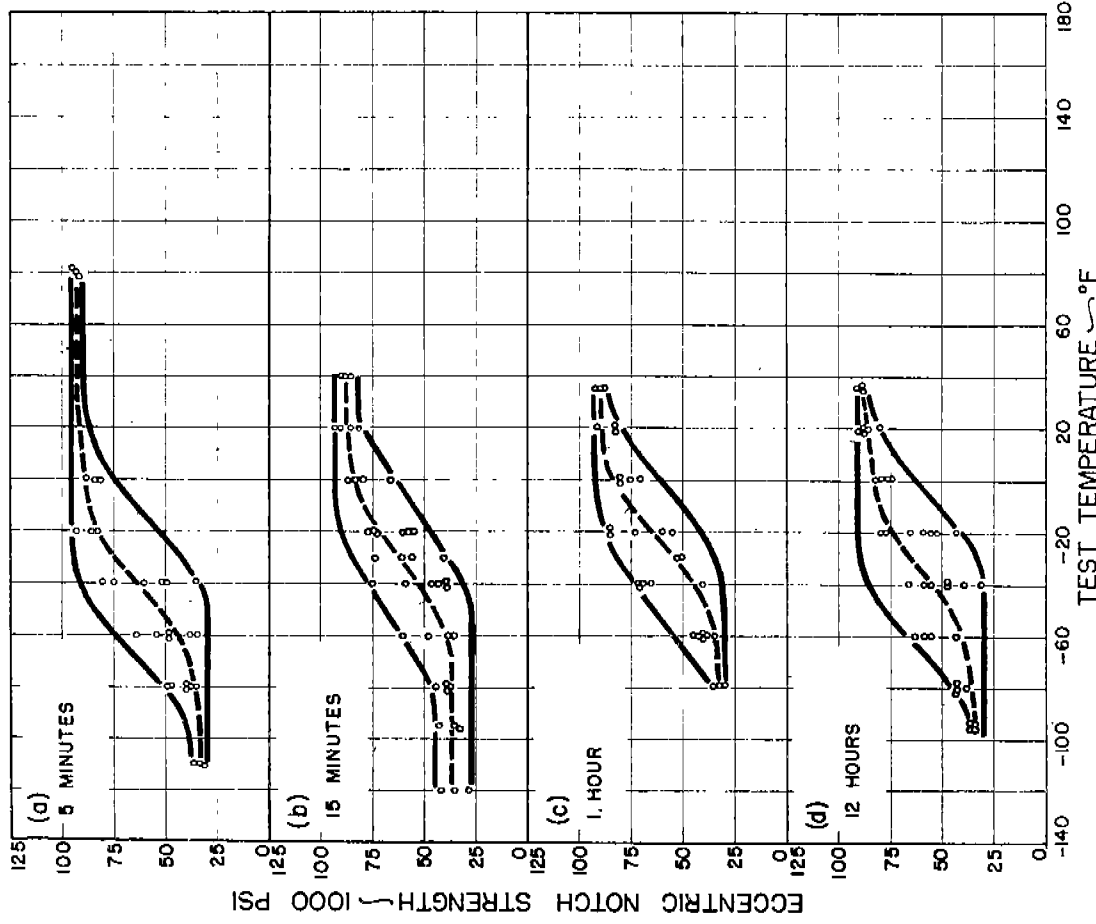
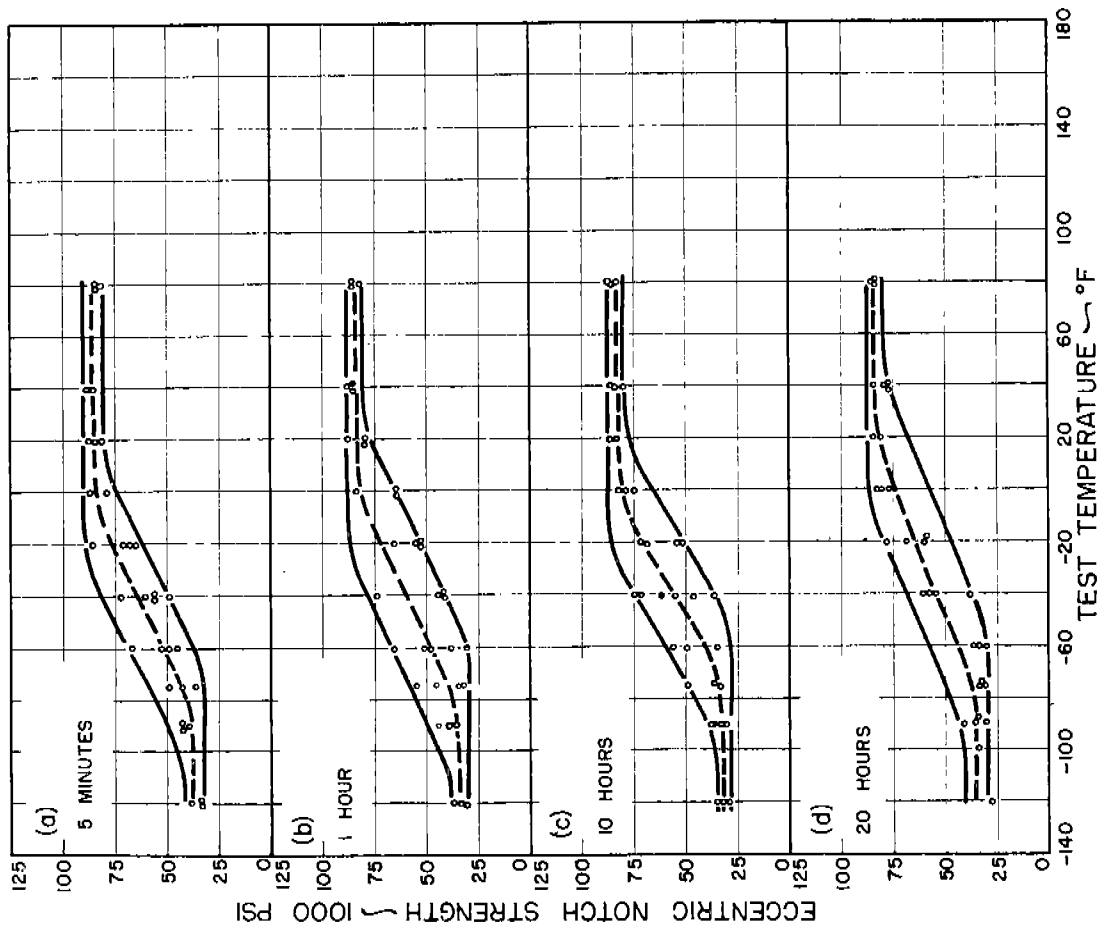

FIG. 5A (CONT.)

FIG. 5A (a-f): ECCENTRIC NOTCH TENSILE TRANSITION CURVES FOR "C" STEEL, SUBCRITICALLY HEATED AT 1100°F FOR TIMES INDICATED AND AIR COOLED. PLATE II.



ECCENTRIC NOTCH STRENGTH, 1000 PSI

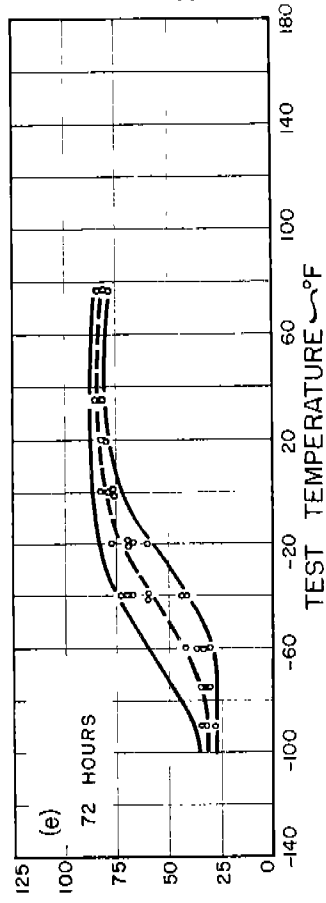

FIG. 6A (CONT.)

FIG. 6A (a-e): ECCENTRIC NOTCH TENSILE CURVES OF "C" STEEL. SUBCRITICALLY HEATED AT 1200°F FOR TIMES INDICATED AND AIR COOLED. PLATE II.

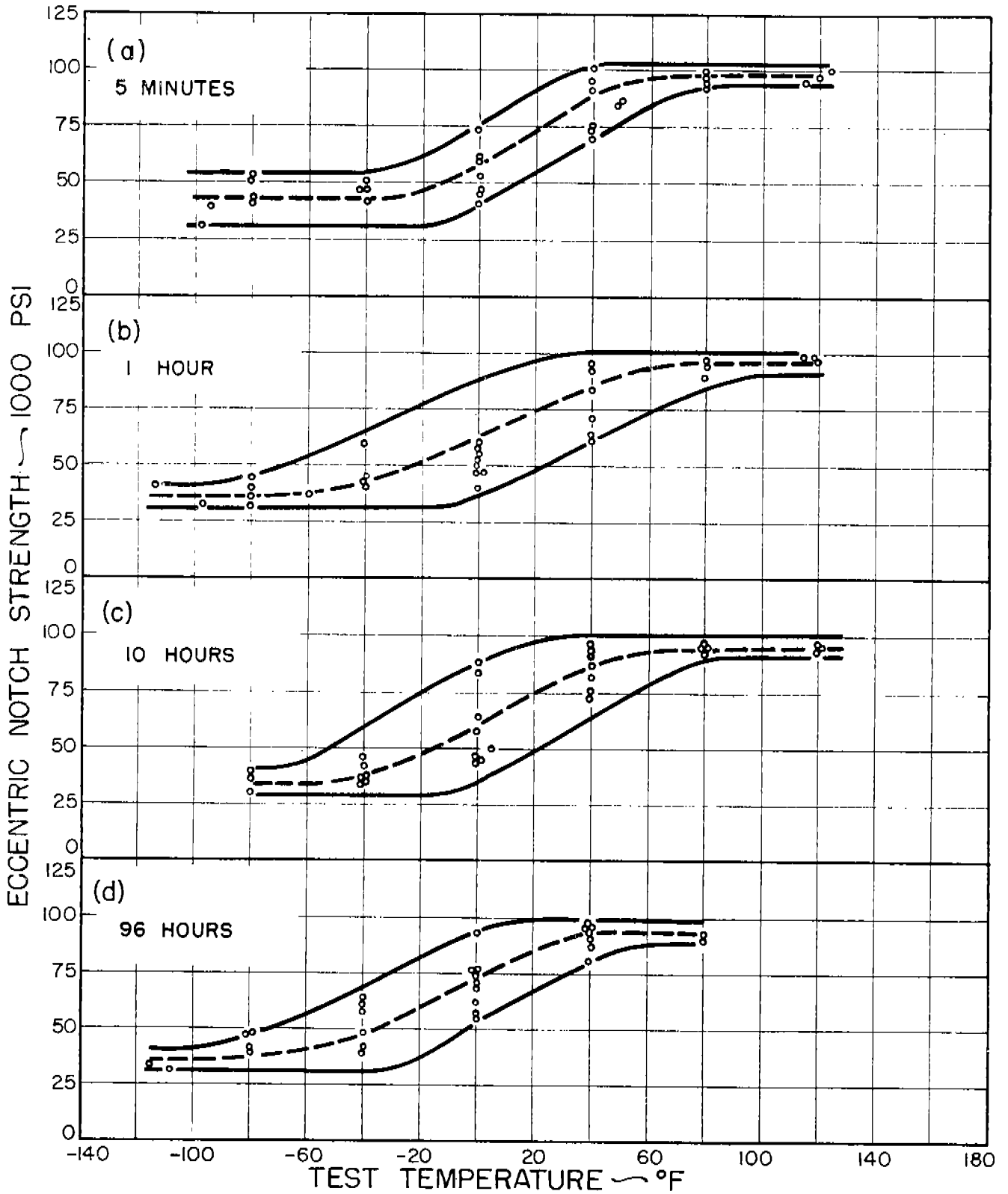

FIG. 7A(a-d): ECCENTRIC NOTCH TENSILE TRANSITION CURVES FOR "C" STEEL. SUBCRITICALLY HEATED AT 1100°F FOR TIMES INDICATED AND WATER QUENCHED. AGED 1 MONTH AT ROOM TEMPERATURE. PLATE II.

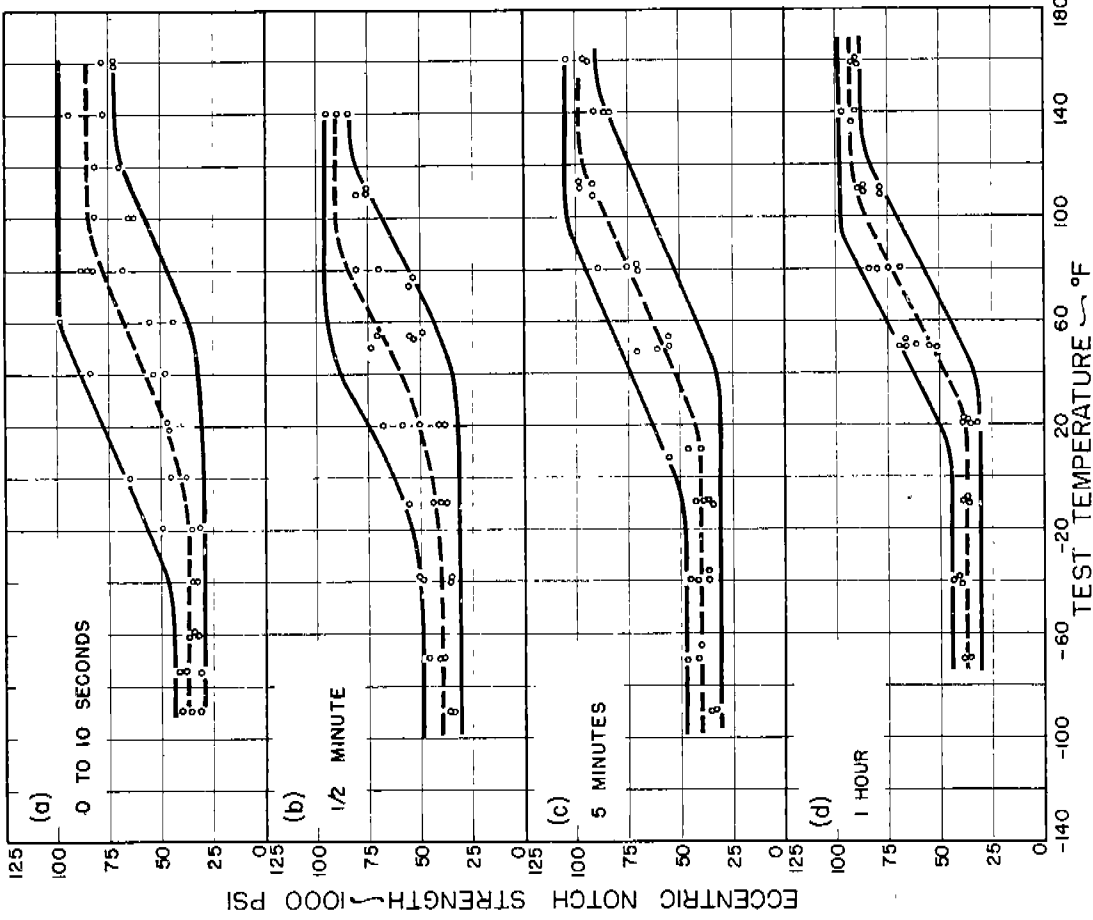

FIG. 8A (a-f): ECCENTRIC NOTCH TENSILE TRANSITION CURVES OF "C" STEEL SUBCRITICALLY HEATED AT 1200°F FOR TIMES INDICATED AND WATER QUENCHED. AGED 1 MONTH AT ROOM TEMPERATURE. PLATE II.

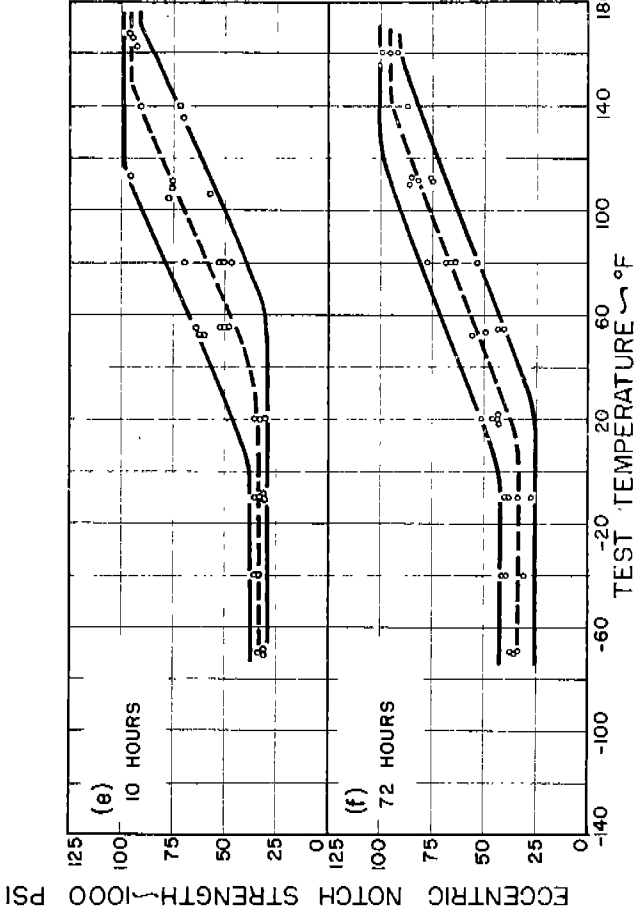

FIG. 8A (CONT.)

APPENDIX B
CHARPY V-NOTCH TRANSITION CURVES
PLATE II

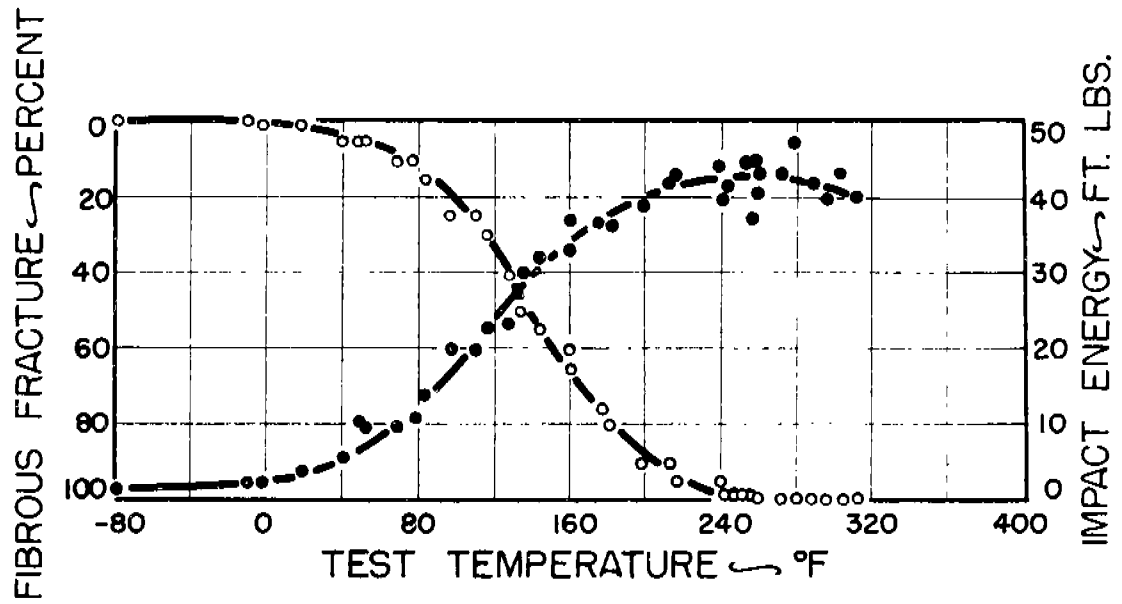

FIG. 1B: CHARPY V-NOTCH TRANSITION CURVES FOR AS-RECEIVED "C" STEEL.

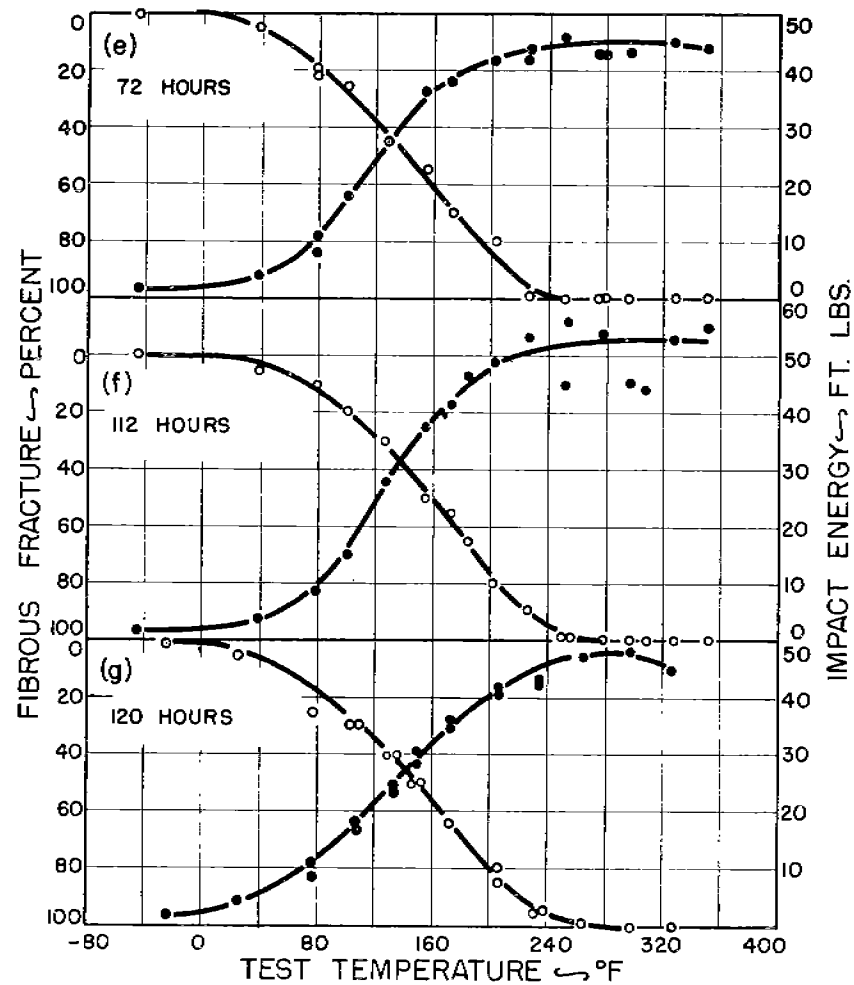
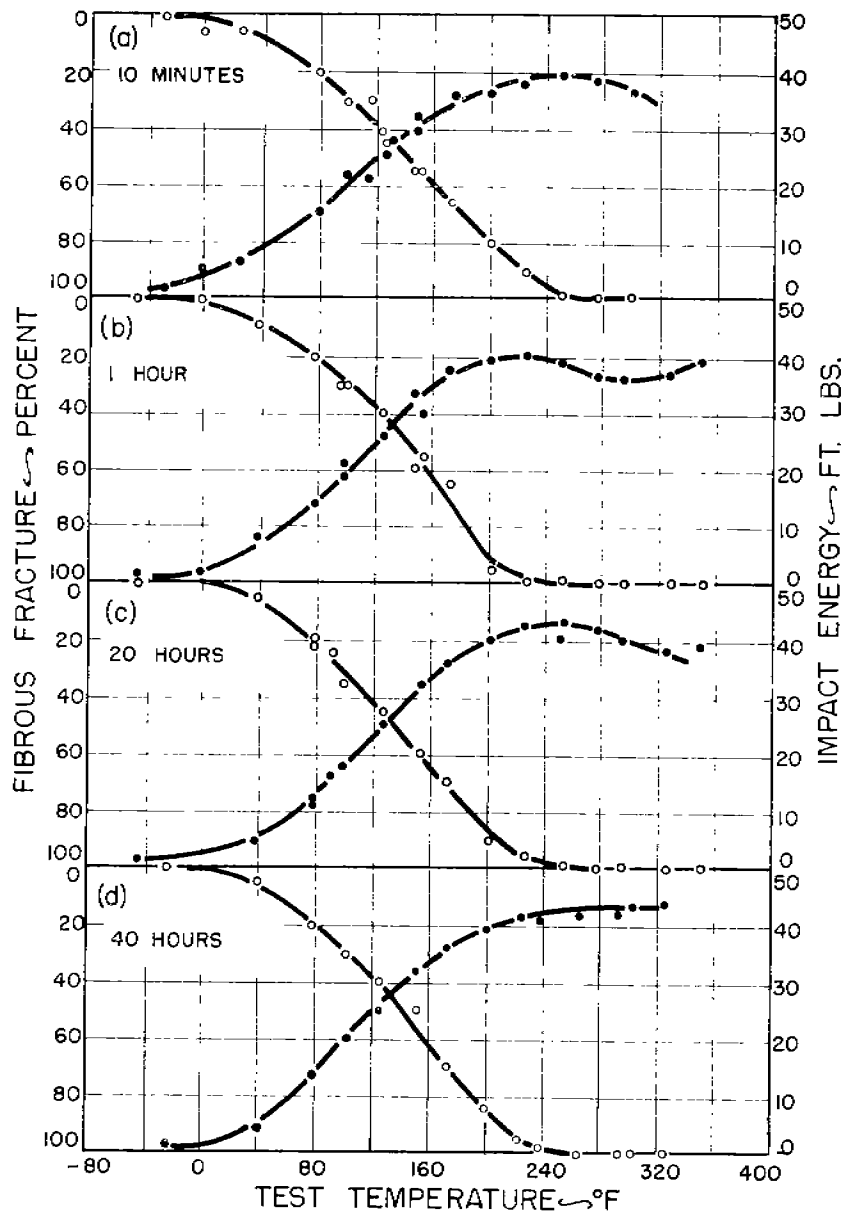

FIG. 2B (CONT.)

FIG. 2B (a-g): CHARPY V-NOTCH TRANSITION CURVES FOR "C" STEEL. SUBCRITICALLY HEATED AT 1100°F FOR TIMES INDICATED AND AIR COOLED.

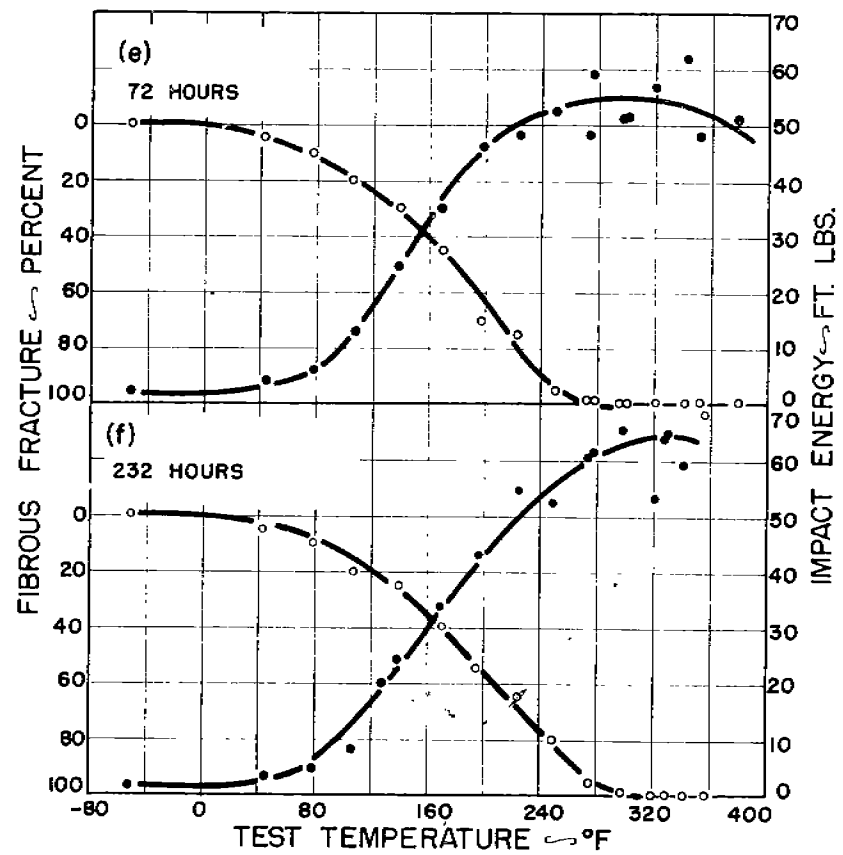
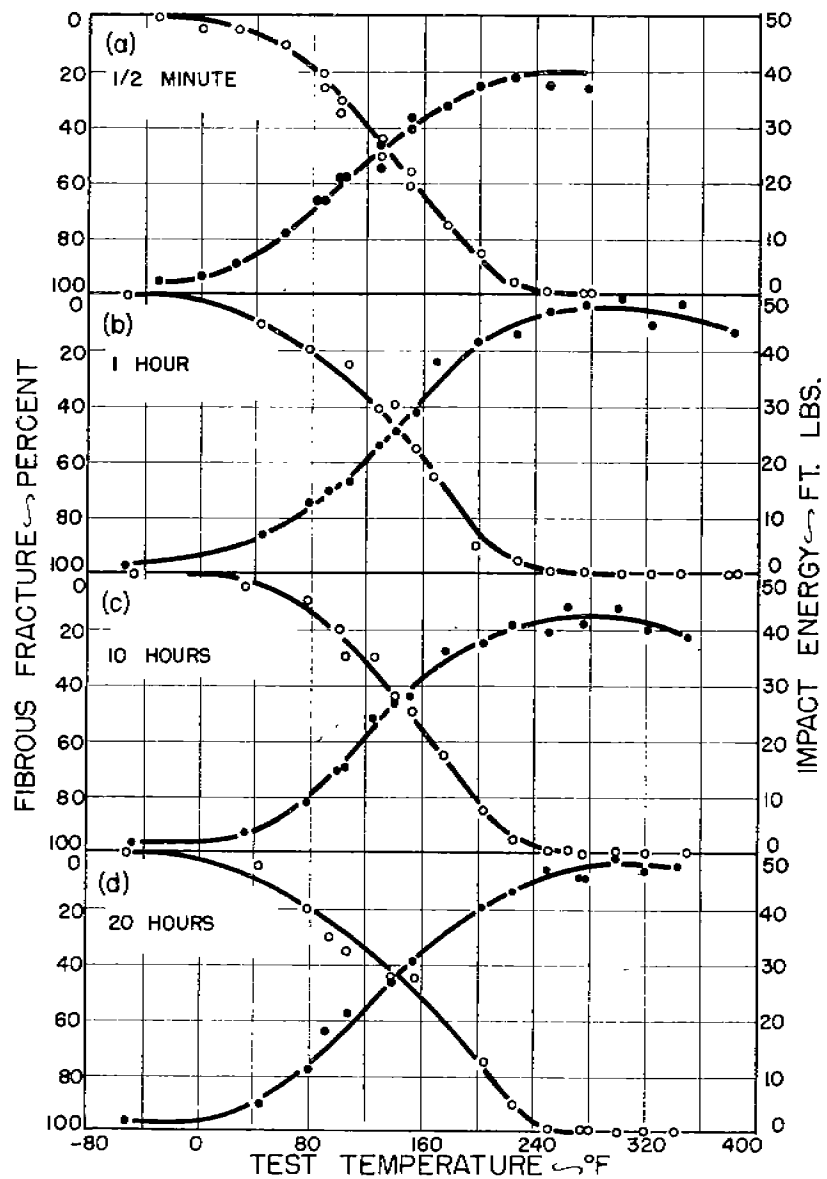

FIG. 3B (CONT.)

FIG. 3B (a-f): CHARPY V-NOTCH TRANSITION CURVES FOR "C" STEEL. SUBCRITICALLY HEATED AT 1200°F FOR TIMES INDICATED AND AIR COOLED.

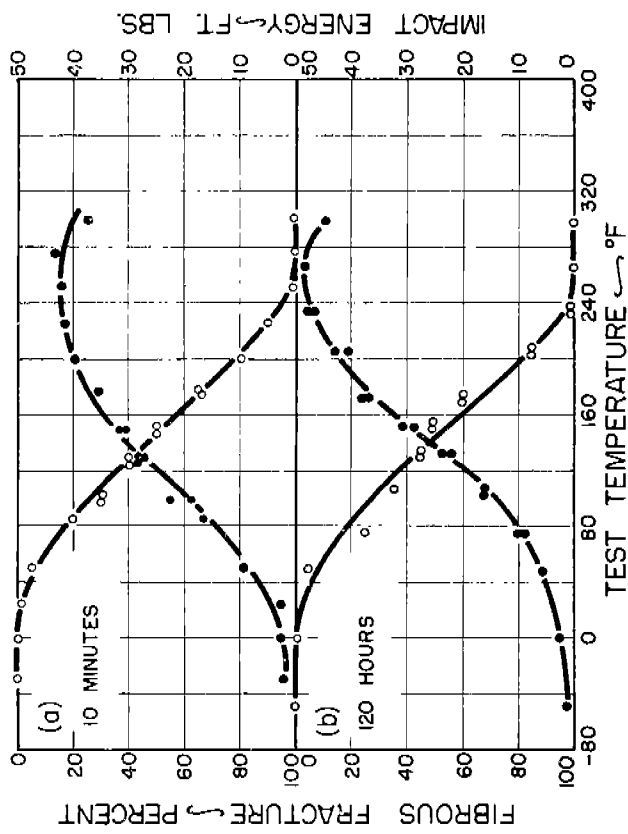

FIG. 4B (a & b): CHARPY V-NOTCH TRANSITION CURVES FOR "C" STEEL, SUBCRITICALLY HEATED AT 1100°F FOR TIMES INDICATED AND FURNACE COOLED.

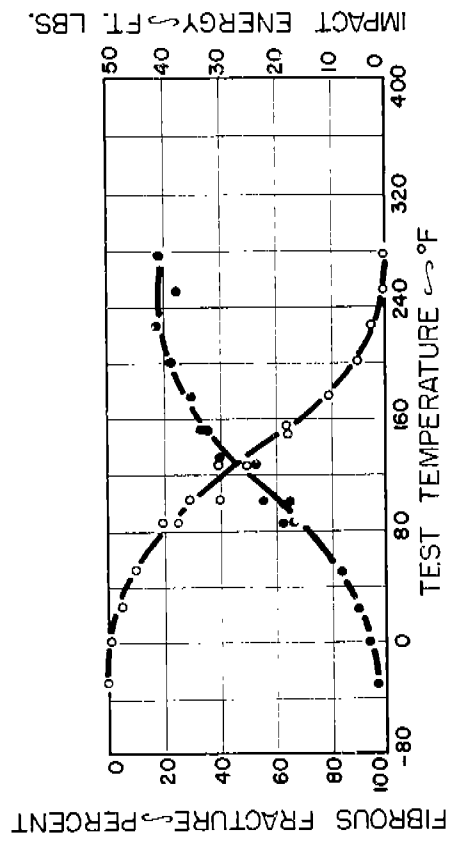

FIG. 5B: CHARPY V-NOTCH TRANSITION CURVES FOR "C" STEEL, SUBCRITICALLY HEATED AT 1200°F FOR 1/2 MINUTE AND FURNACE COOLED.

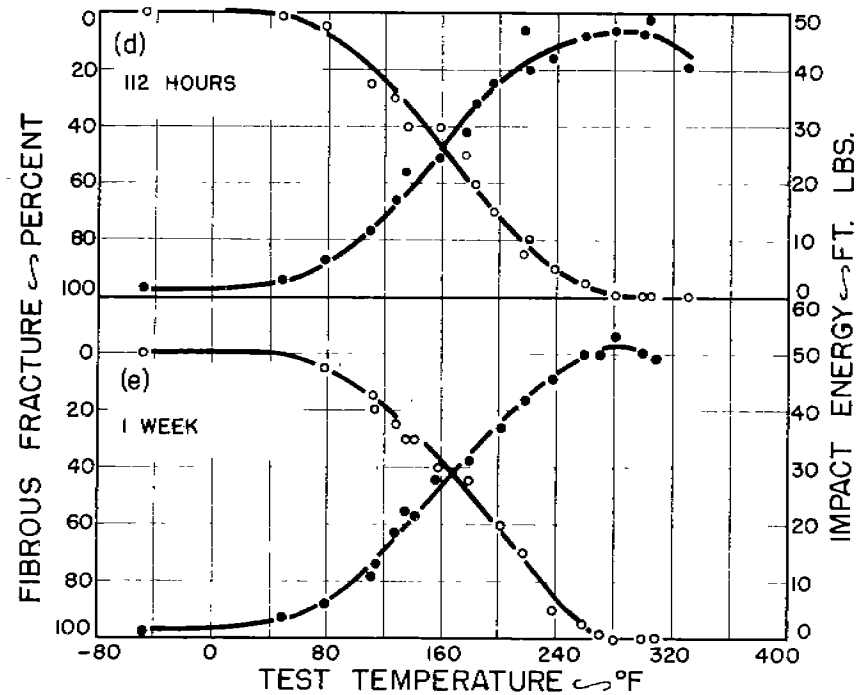
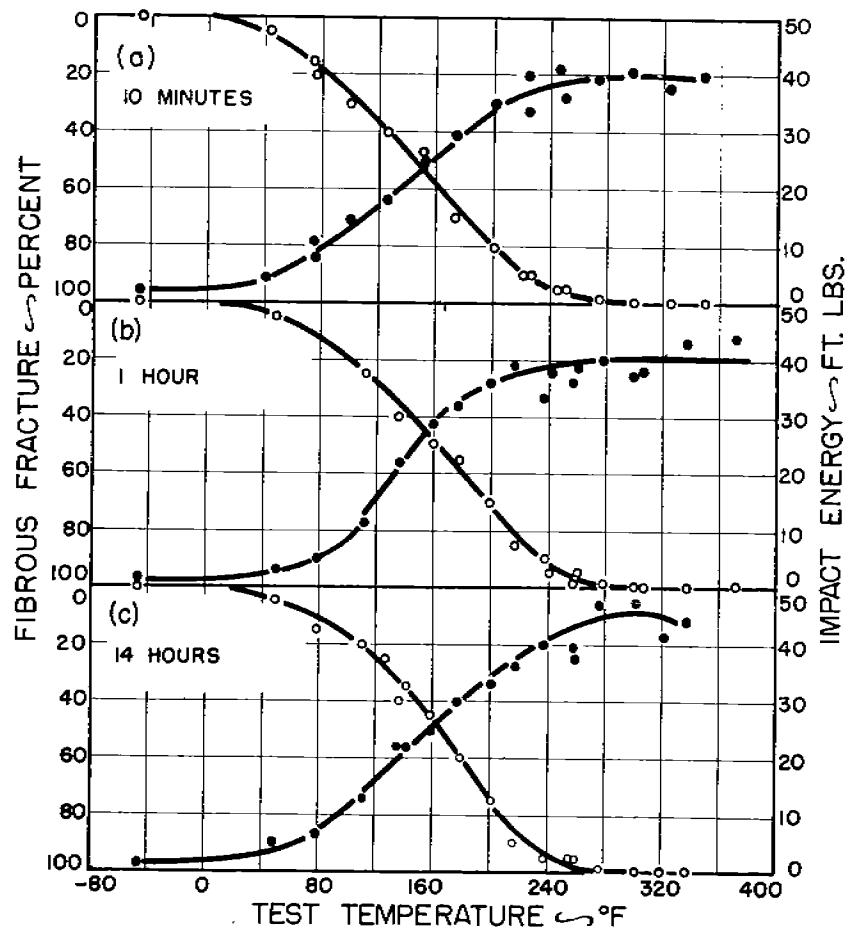

FIG. 6B (CONT.)

FIG. 6B(a-e): CHARPY V-NOTCH TRANSITION CURVES FOR "C" STEEL. SUBCRITICALLY HEATED AT 1100°F FOR TIMES INDICATED AND WATER QUENCHED. AGED 1 MONTH AT ROOM TEMPERATURE.

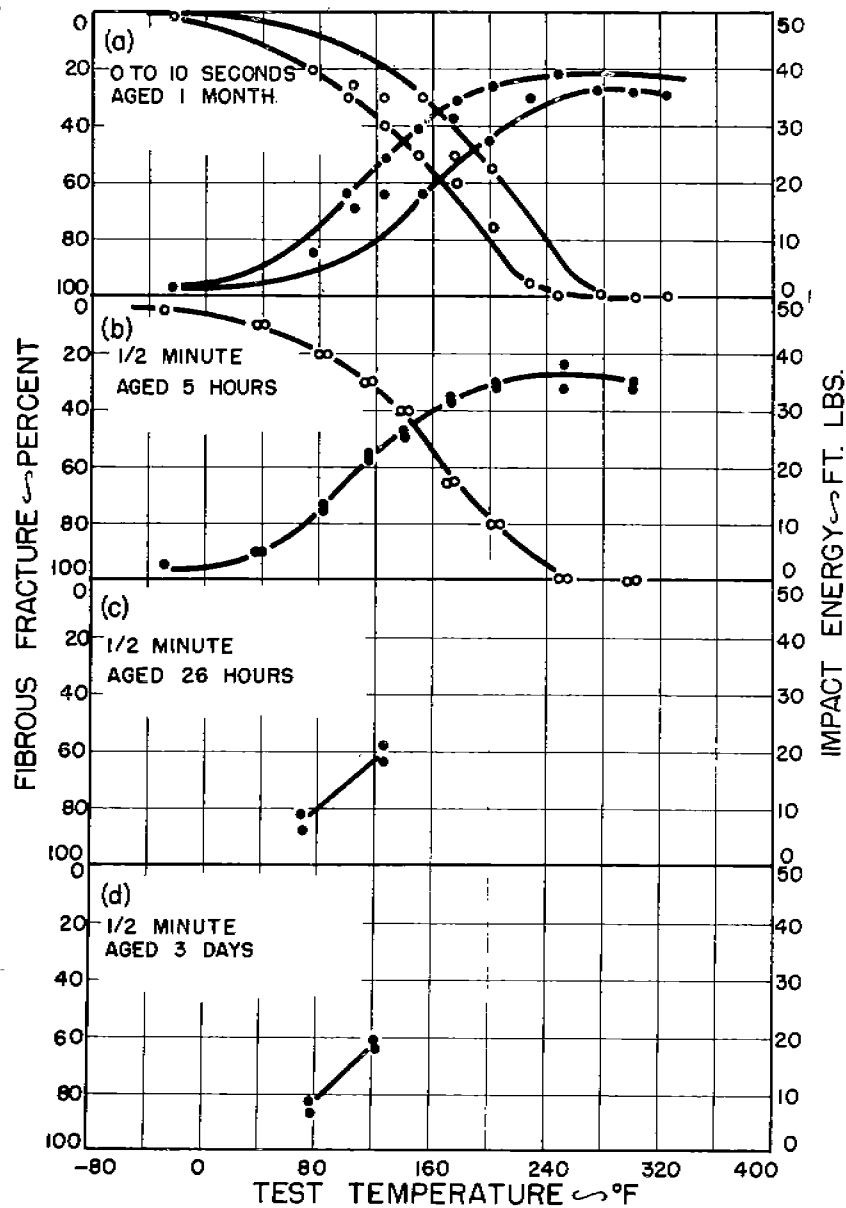

FIG. 7B (a-d): CHARPY V-NOTCH TRANSITION CURVES FOR "C" STEEL. SUBCRITICALLY HEATED AT 1200°F FOR TIMES INDICATED AND WATER QUENCHED. AGED AT ROOM TEMPERATURE.

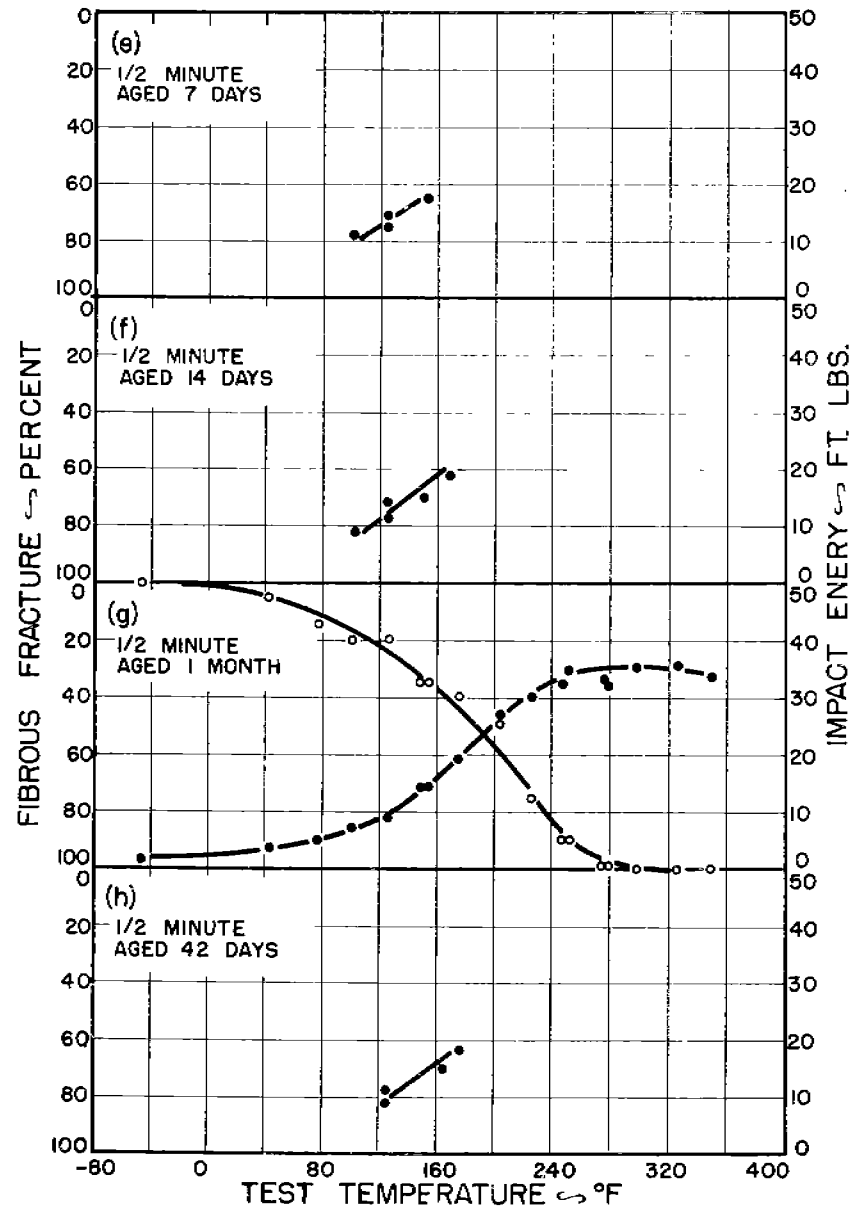

FIG. 7B (CONT.)

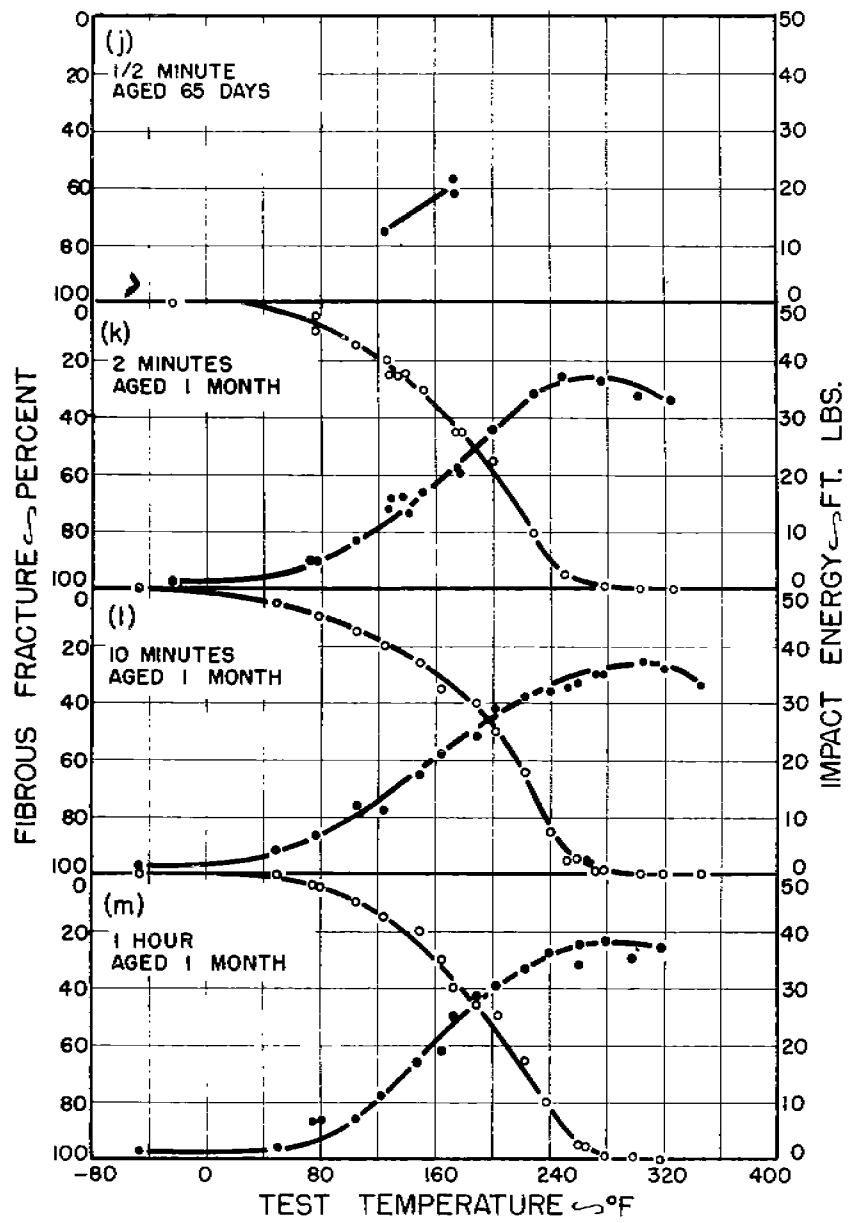

FIG. 7B (CONT.)

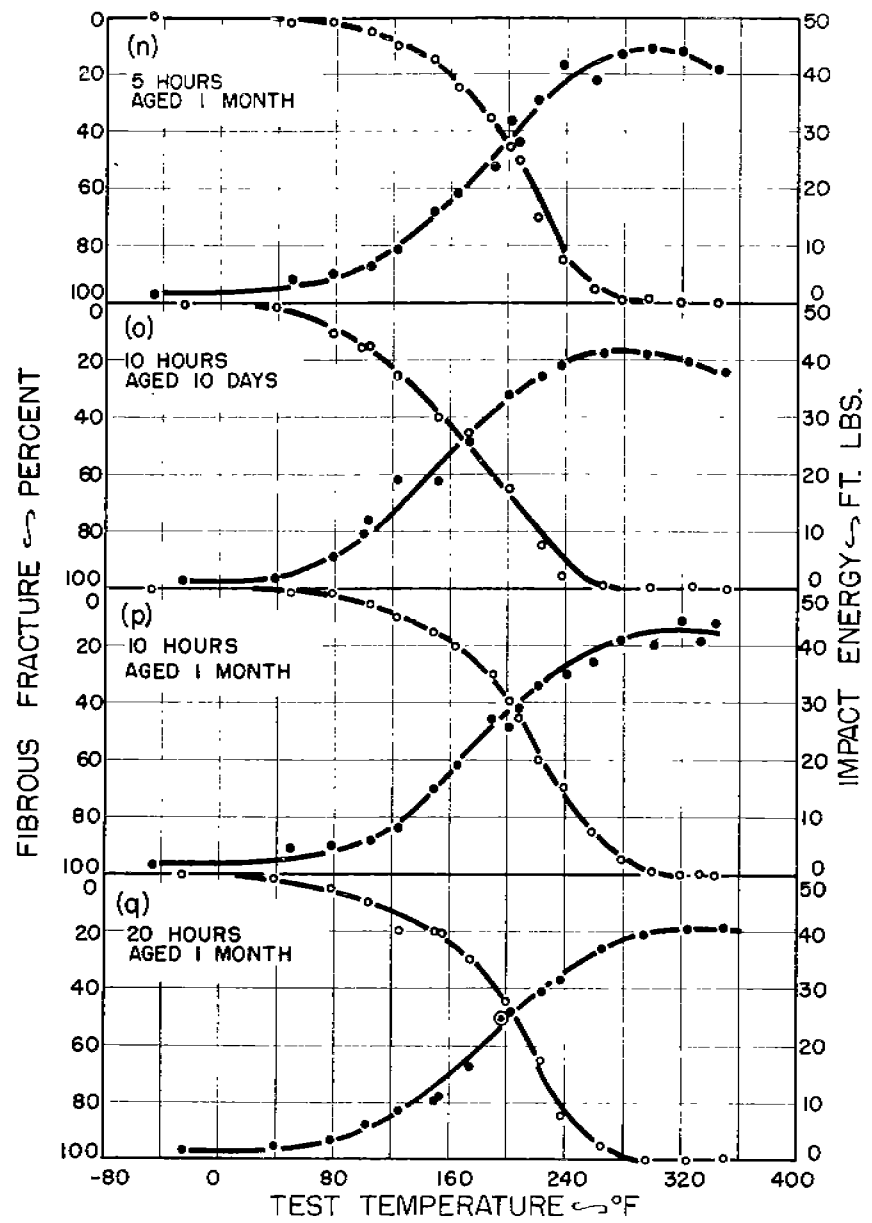

FIG. 7B (CONT.)

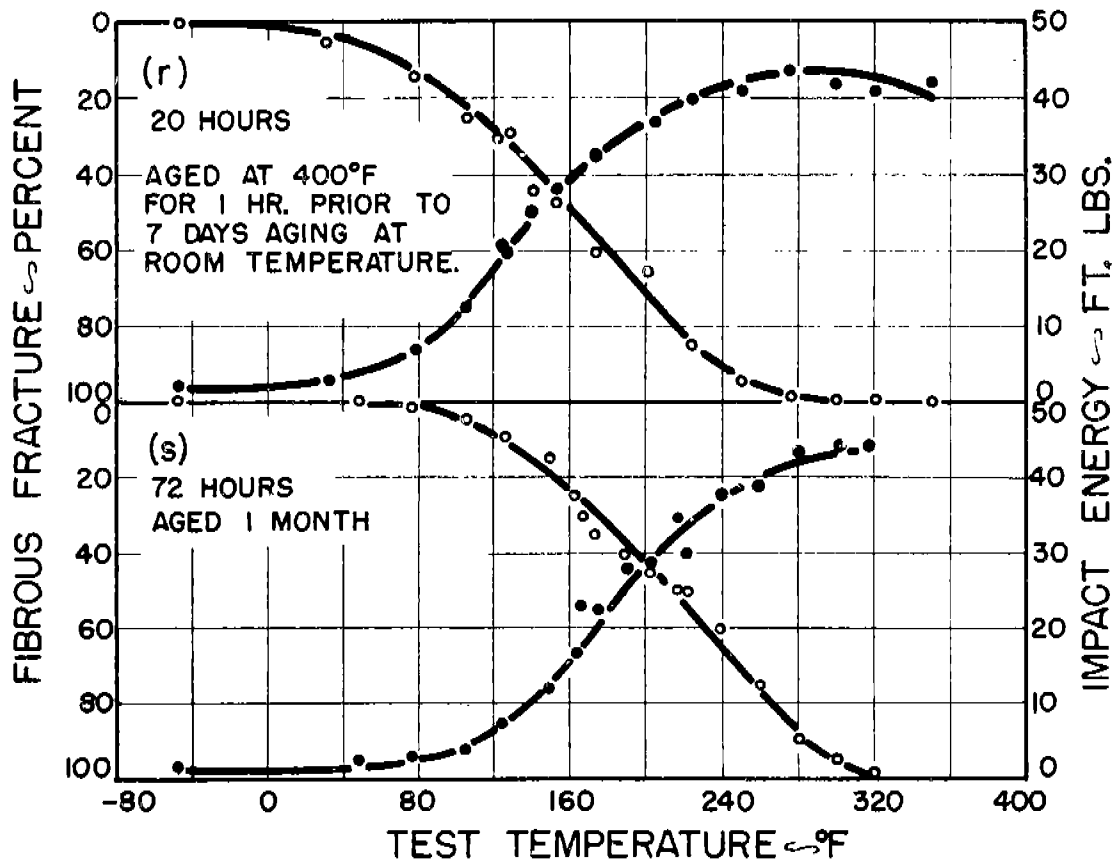

FIG. 7B (CONT.)

SUPPLEMENT
EMBRITTLLEMENT OF "C" STEEL BY NITROGEN

INTRODUCTION

In the first stages of the investigation on the effect of subcritical heat treatment on the transition temperature of "C" steel, both air and a nitrate salt bath were used as the heating media. It was noticed that, generally, test specimens heated in the salt had higher transition temperatures and hardnesses than specimens comparably heated in air. This anomalous behavior was revealed in both the Charpy V-notch impact and the eccentric notch tensile data, and led to the supposition that the salt was introducing an embrittling agent, whose effect was superimposed on the effect of subcritical heat treatment. Metallographic examination, chemical analyses, and x-rays showed the embrittling agent to be nitrogen.

Although not pertinent to the present investigation, the results obtained by subcritical heat treatment in a nitrate salt bath are of sufficient interest to be reported here and compared with those previously obtained after heat treating in air.

MATERIAL AND PROCEDURE

The procedure for both the Charpy V-notch and eccentric

TABLE I

Transition Temperature and Hardnesses of
Charpy V-Notch Specimens after Subcritical Heat
Treatment in Nitrate Salt Bath

<u>Time at Temperature</u>	<u>R_B Hardness</u>	<u>Transition Temperature, °F</u>		
		<u>Midpoint</u>	<u>50% Fibrous Fracture</u>	<u>15 Ft-Lbs</u>
As Received	74-76	118	138	87
<u>700°F, Air Cool</u>				
1 hour	73	125	142	92
10 hours	73	125	145	90
30 hours	73	128	145	92
1 week	73	123	142	88
<u>950°F, Air Cool</u>				
5 minutes	73	120	140	85
6 hours	73	123	148	88
24 hours	83	125	165	95
1 week	85	165	207	147
<u>1100°F, Air Cool</u>				
5 minutes	73	117	140	85
1 hour	73	120	145	85
10 hours	73	125	150	90
112 hours	86	208	240	192
<u>1100°F, Furnace Cool</u>				
112 hours	85	210	248	197
<u>1100°F, Water Quench*</u>				
4 1/2 hours	94	136	168	130
20 hours	99	205	225	200
112 hours	101	295	308	292

*Aged one month at room temperature before testing.

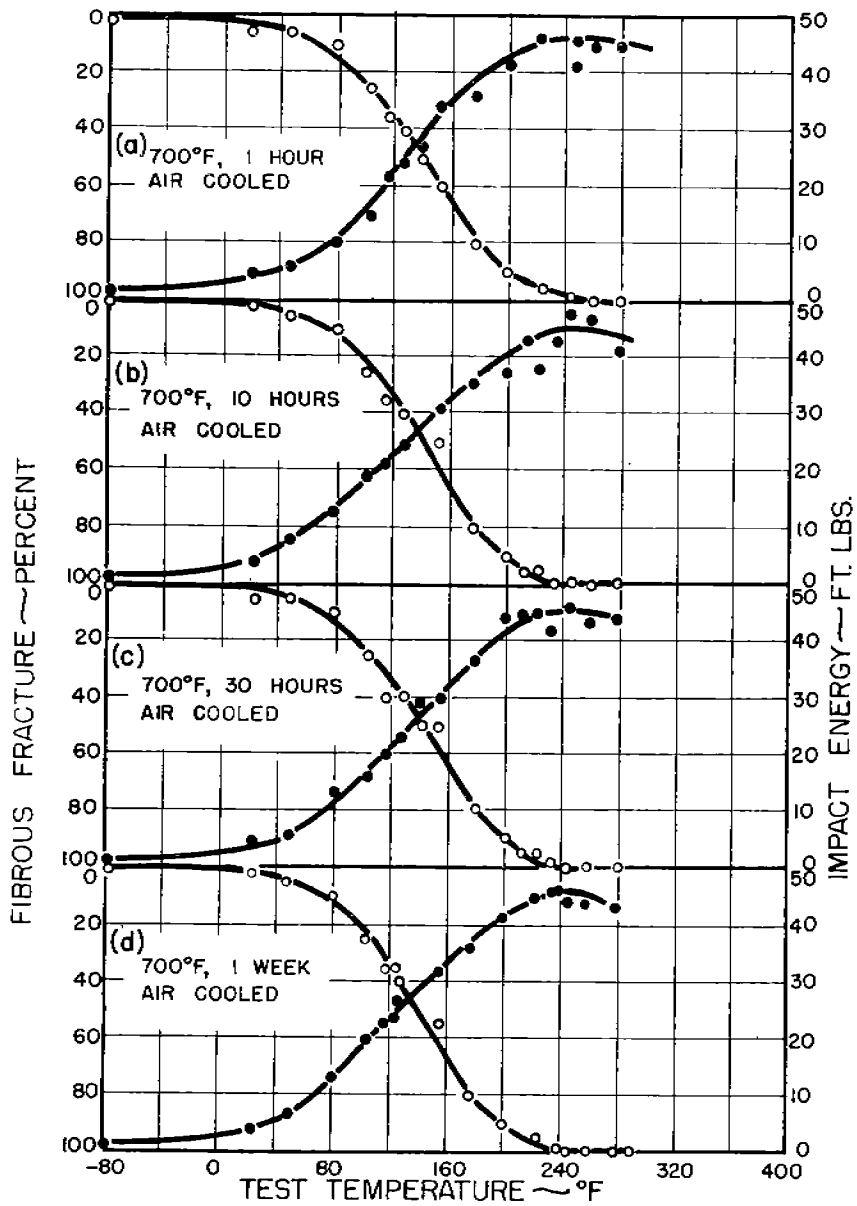

FIG. 1(a-q): CHARPY V-NOTCH TRANSITION CURVES OF "C" STEEL AFTER VARIOUS SUBCRITICAL HEAT TREATMENTS IN NITRATE SALT.

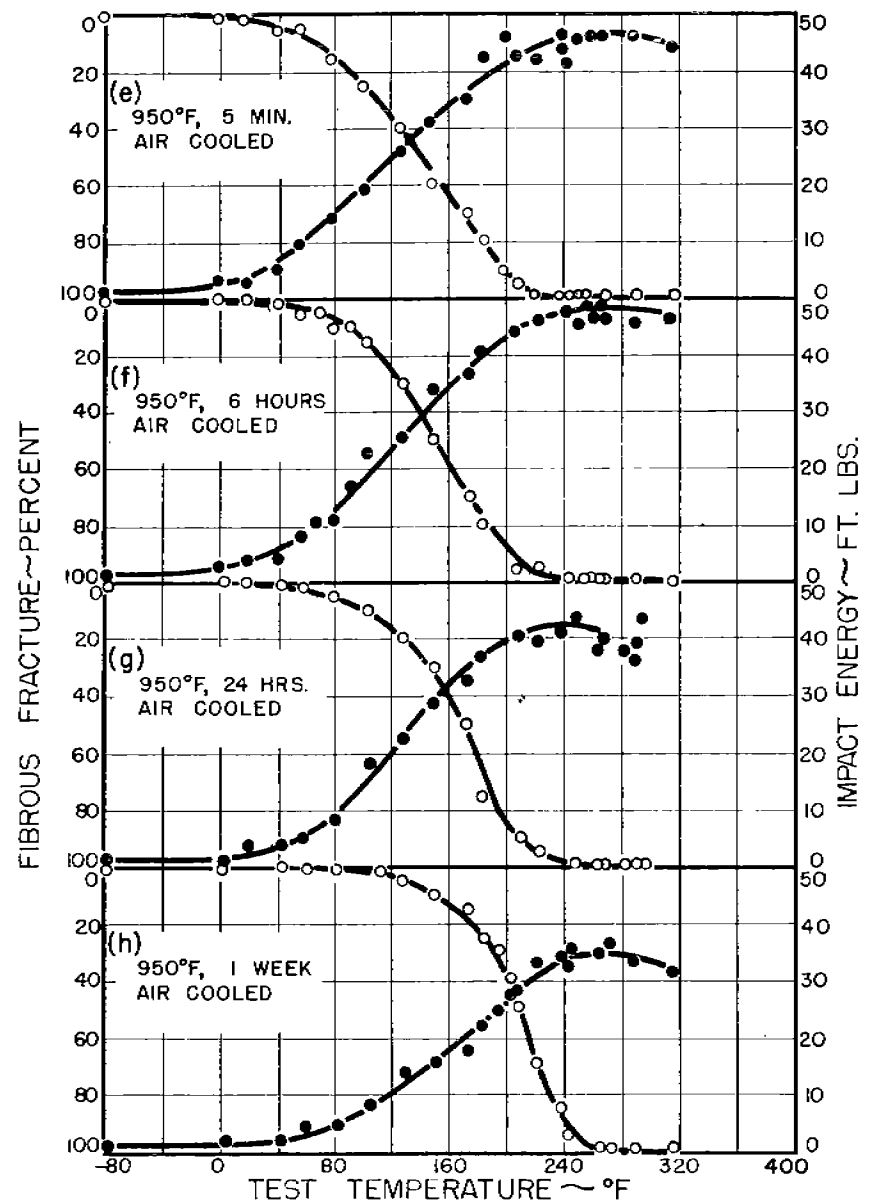

FIG. 1 (CONT.):

notch tensile specimens were the same as described in the report proper, with the exception that the subcritical heat treatments were carried out in an immersed electrode type of salt bath. The salt was a nitrate mixture of the following composition: 40%, KNO_3 and 60%, NaNO_3 .

A summary of the various heat treatments used and the resulting transition temperatures and hardnesses are given in Tables I and II for the impact and the notch tensile specimens, respectively. All specimens were obtained from the same large plate (Plate II) of "C" steel.

RESULTS AND DISCUSSION

Transition Temperatures After Subcritical Heat Treatment

The individual impact transition curves for the various heat treatments in the nitrate salt bath are shown in Fig. 1 (a-q), and the notch tensile transition curves in Fig. 2 (a-g).

The same criteria of embrittlement--15 ft-lb value for impact specimens and midpoint value for notch tensile specimens--have been employed as in the preceding report.

Air Cooled--Fig. 1 (a-m) and Fig. 2 (a-g) show the individual transition curves of impact and notch tensile tests, respectively, after heating in the 700°--1100°F temperature range for various times, employing an air cool. An examination of the curves for both specimen types shows that not only is the transition range shifted to higher testing temperatures

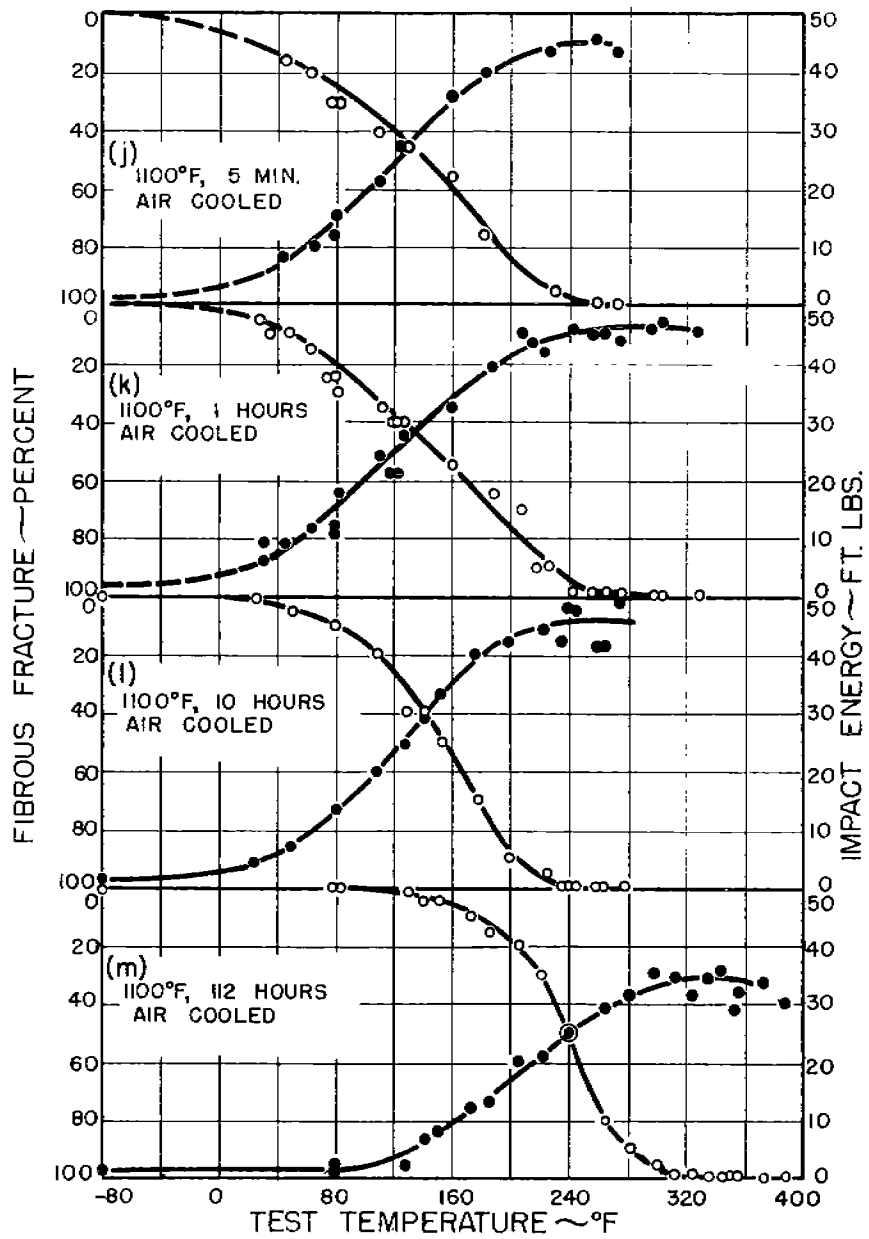

FIG. 1 (CONT.):

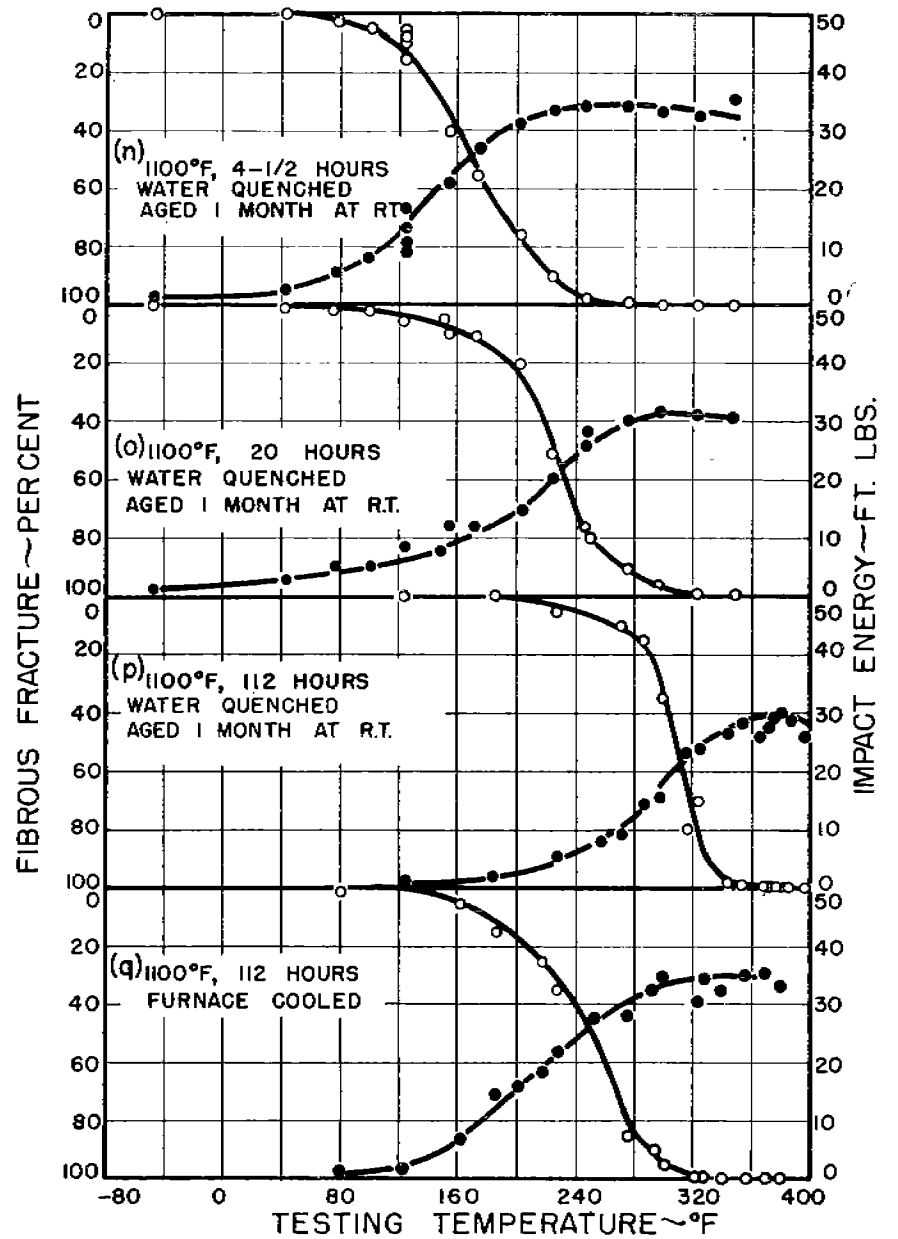

FIG. 1 (CONT.)

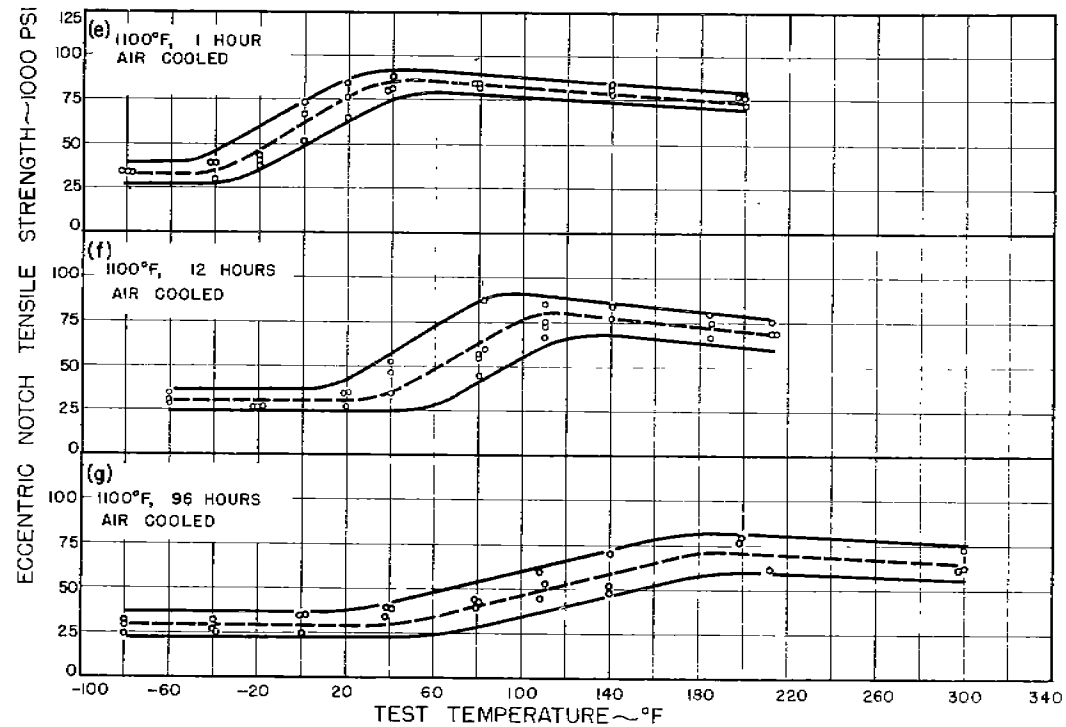
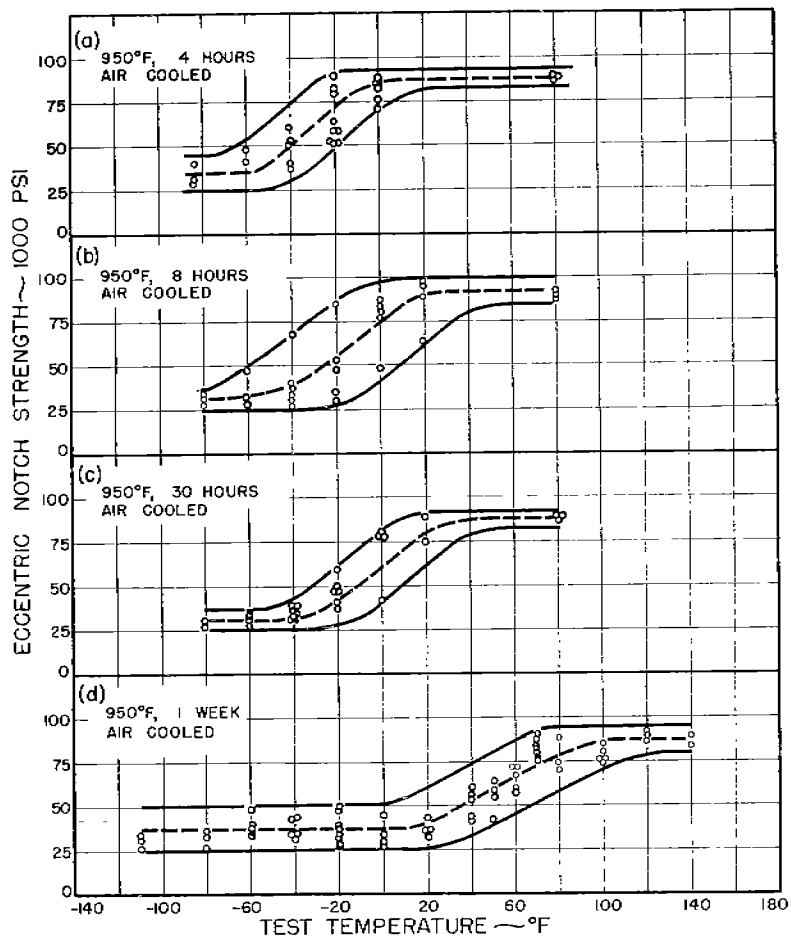

FIG. 2: ECCENTRIC NOTCH TENSILE TRANSITION CURVES OF "C" STEEL AFTER VARIOUS SUBCRITICAL HEAT TREATMENTS IN NITRATE SALT.

72

with both increasing subcritical temperature and time, but the upper level is lowered as well. In addition, the hardness correspondingly increases. This is in contrast to the air heated specimens noted previously, which show the transition range is relatively unaffected and the upper level increases with increasing time and temperature.

This embrittling effect is more evident in Fig. 3, wherein the transition temperature is plotted as a function of time at the various temperatures for both specimen types and compared with the results after comparable heat treatments in air*. In the impact test the transition temperature is constant with time at least up to one week at 700°F. At 950°F the transition temperature starts to rise after about 20 hours, and after one week, has increased 60°F. At 1100°F an increase in transition temperature is noted after about 20 hours, increasing 105°F after 112 hours.

With the notch tensile test a comparison of the nitrate salt and air heating media shows that the salt starts to embrittle the steel after about 2 hours at 950°F and 1/2 hour at 1100°F. After one week at 950°F, the transition temperature has been raised about 100°F; after 96 hours at 1100°F, the transition temperature has been increased about 150°F.

Thus, the two specimen types show that the magnitude of

*See preceding report.

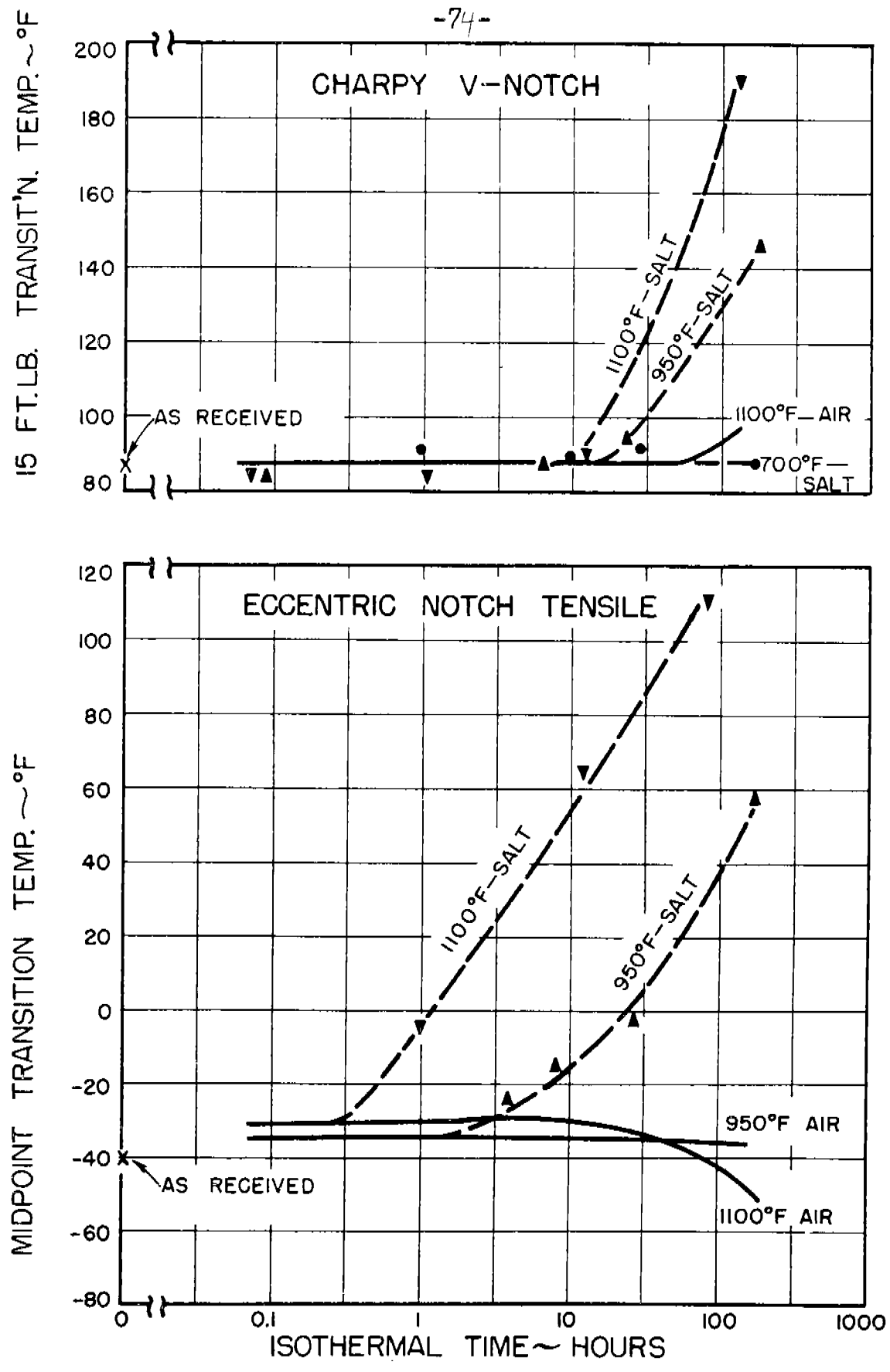

FIG. 3: TRANSITION TEMPERATURES OF "C" STEEL RESULTING FROM VARIOUS SUBCRITICAL HEAT TREATMENTS IN NITRATE SALT BATH AND IN AIR, EMPLOYING AN AIR COOL.

the embrittlement increases with both time and temperature.

Furnace Cooled--One series of impact specimens was tested in the furnace cooled condition after heating at 1100°F for 112 hours. A comparison of the transition curve for this treatment, Fig. 1q, with that of the same heat treatment employing an air cool, Fig. 1m, shows the same embrittling effect and of the same magnitude. The hardness checks also show that the specimens are embrittled to the same degree.

Water Quenched--The individual impact transition curves obtained after heating at 1100°F for various times, employing a water quench* are plotted in Figs. 1 (n-p). These curves show that the transition range is shifted to higher testing temperatures and the upper level lowered with increasing time at 1100°F. This is also followed by an increasing hardness with time.

Fig. 4 provides a comparison of the transition temperatures after heat treatment in the nitrate salt with those after comparable heat treatments in air. As in the air cooled series, it is evident that the nitrate salt has introduced some embrittling agent whose effect is now noticeable after about 4 hours at 1100°F. From an embrittlement amounting to about 30°F rise in transition temperature at this point, the embrittlement continually increases with time, amounting to a 200°F increase in transition temperature after 112 hours.

*Aged one month at room temperature

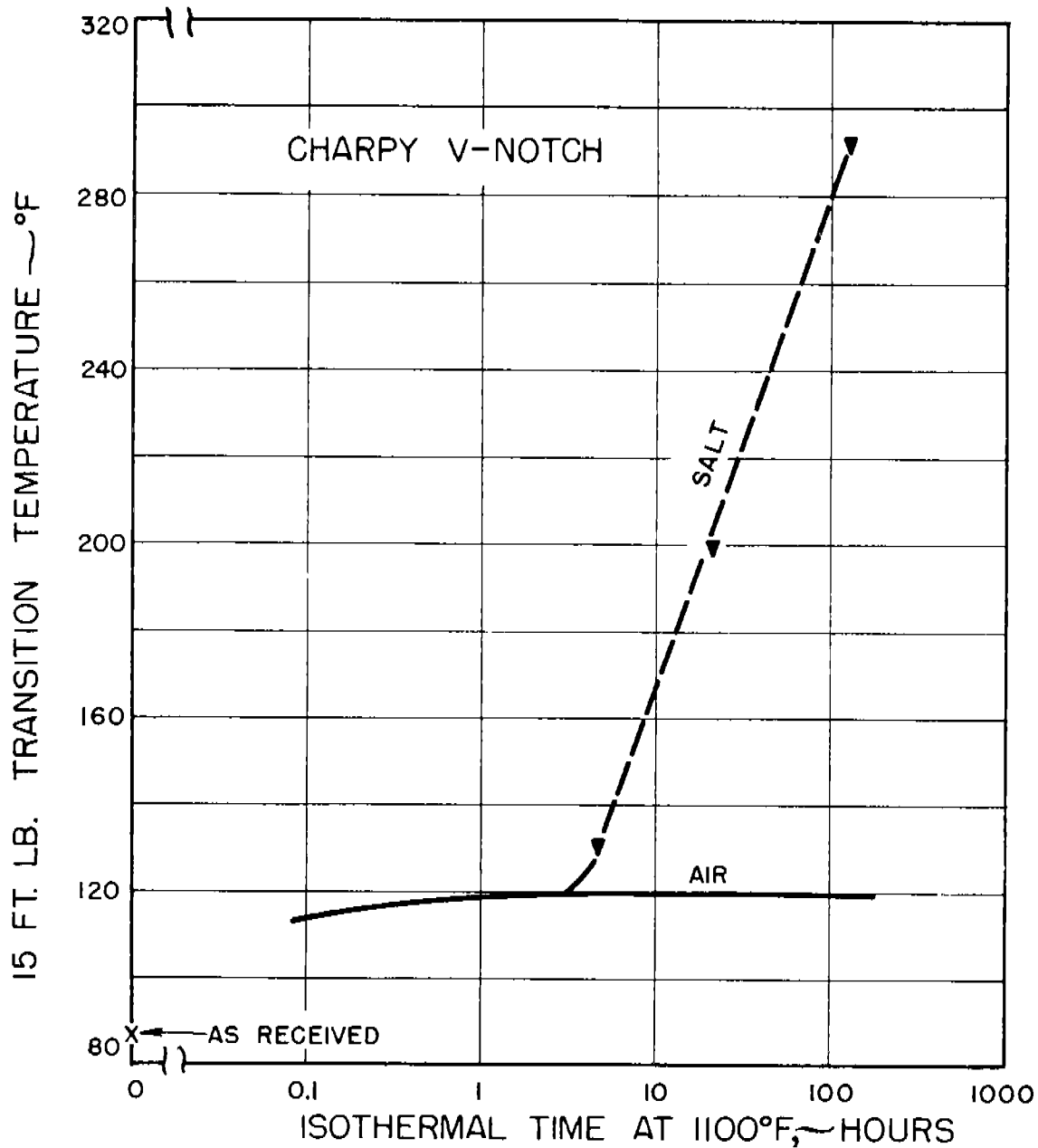

FIG. 4: TRANSITION TEMPERATURES OF "C" STEEL RESULTING FROM HEATING AT 1100°F FOR VARIOUS TIMES IN NITRATE SALT BATH AND IN AIR, EMPLOYING A WATER QUENCH. AGED ONE MONTH AT ROOM TEMPERATURE.

Fig. 5 is a summary curve, comparing the Charpy transition temperatures of the air cooled and water quenched series from 1100°F, using both nitrate salt and air as the heating media. It is apparent that, for a given medium, the relation of transition temperature--isothermal time for the air cooled series--is displaced below and approximately parallel to that of the water quenched series. For either the water quenched or the air cooled series, there appears to be an incubation period before the effect of the nitrate salt on the transition temperature is noticeable. With increasing time the embrittling action of the nitrate salt is evident in a continuous increase in transition temperature at about the same rate for either the air cooled or water quenched series.

In Fig. 6 the individual transition curves obtained after heating at 1100°F for 112 hours are compared for the two heating media, employing both a water quench and an air cool. For a given cooling rate, the extreme embrittlement introduced by heat treatment in the nitrate salt is clearly revealed by a shift of the transition range to higher testing temperatures and a lowering of the maximum level.

Microstructures--In order to detect any structural differences which would account for the anomalous results between specimens heated in nitrate salt and in air, a number

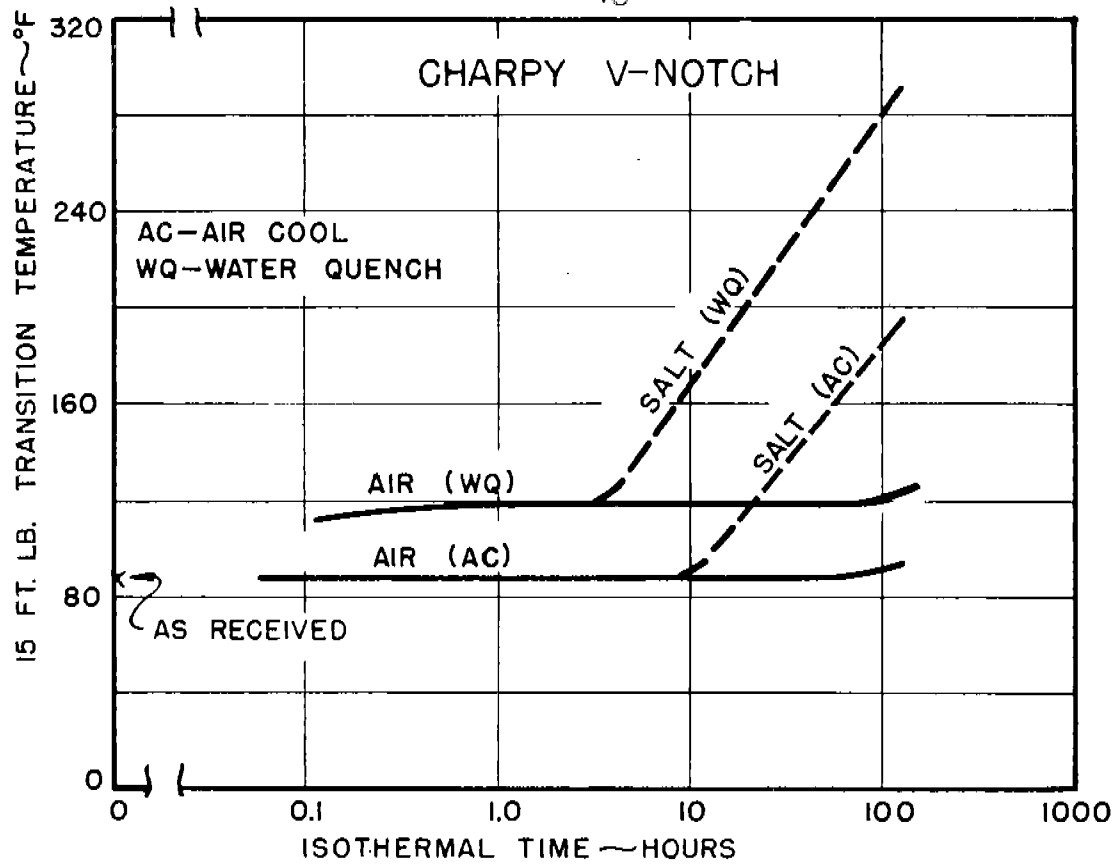

FIG. 5: CHARPY TRANSITION TEMP.-ISOTHERMAL TIME CURVES AFTER HEAT TREATMENT AT 1100°F IN NITRATE SALT BATH AND IN AIR.

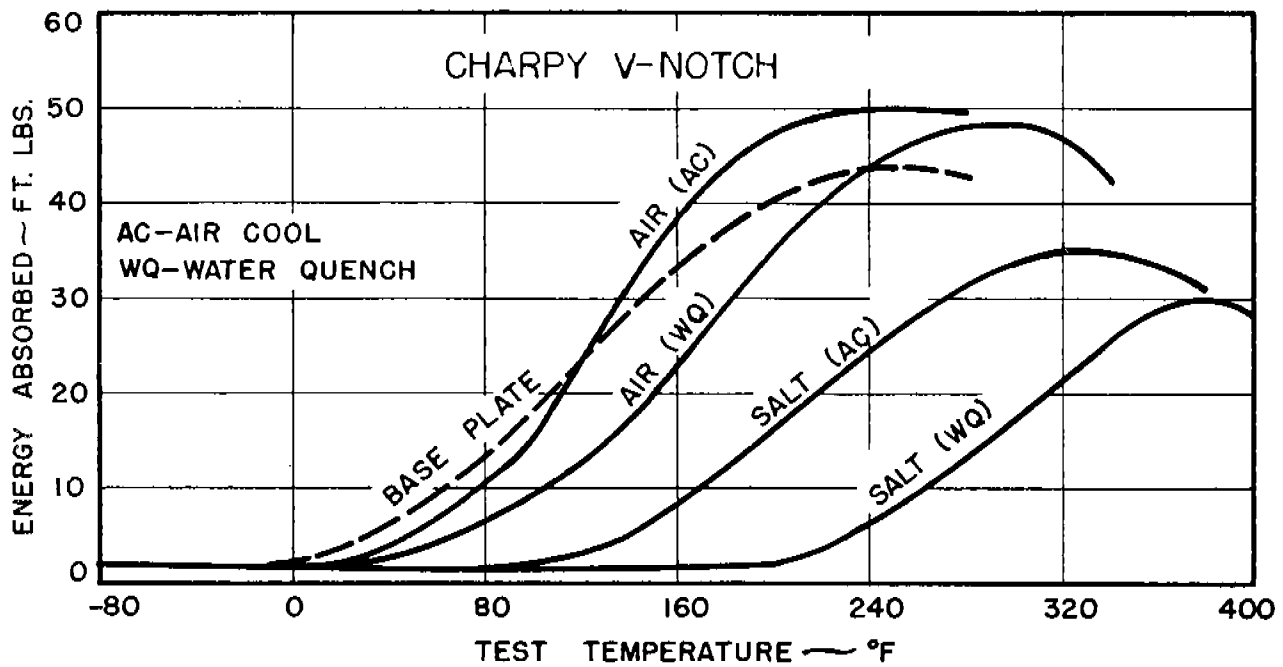

FIG. 6: CHARPY TRANSITION CURVES AFTER HEAT TREATMENT AT 1100°F FOR 112 HOURS IN NITRATE SALT BATH AND IN AIR.

of photomicrographs were made at 2000X, Fig. 7, showing the structures after heating at 1100°F for 112 hours.

The air cooled and water quenched structures after heat treatment in the salt are shown in Figs. 7b and c respectively. The only difference evident between these structures, is the mottled appearance of the ferrite in the water quenched specimen. A comparison of these structures with the as-received plate, Fig. 7a, indicates that slight spheroidization is present after the subcritical heat treatment.

With a furnace cool, an unusual microstructure was evident after the nitrate salt heat treatment. Fig. 7d taken at the center of a Charpy bar shows short plates of a precipitate arranged in a Widmanstätten pattern. At the edge, Fig. 7e, a mixed precipitate of short plates and long needle-like plates apparently nucleated at the grain boundaries is evident. This precipitate, then seems to be associated with a critical cooling rate.

The two different forms of the precipitate suggest a concentration gradient from the edge to the core, and their form and distribution suggest nitride needles. This structure is not present in the comparable series heat treated in air and furnace cooled, Fig. 7f, even though "C" steel has the highest original nitrogen content of the project steels; thus, it would appear that the nitrate salt



(c) 1100°F (Nitrate salt)
112 hrs. water quench



(b) 1100°F (Nitrate salt)
112 hrs. air cool.

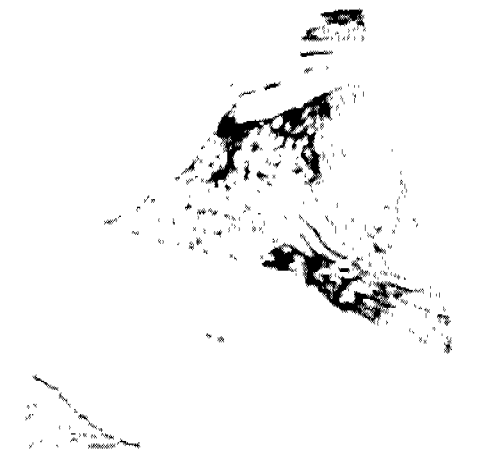

(a) As-Received



(e) Same as (d) except
edge of Charpy bar.



(d) 1100°F (nitrate salt) 112 hrs.
furnace cool. Center of Charpy Bar



(f) 1100°F (air), 112 hrs.
furnace cool.

Fig. 7: - MICROSTRUCTURES OF "C" STEEL IN THE AS-RECEIVED CONDITION AND AFTER VARIOUS SUBCRITICAL HEAT TREATMENTS IN NITRATE SALT BATH AND IN AIR. NITAL ETCH. 2000X

served to introduce nitrogen during subcritical heat treatment.

Electron micrographs prepared by Dr. A. Revere at 6,000 and 12,000 diameters showed substantially the same features as the optical micrographs.

Nitrogen Analyses--To confirm that the specimens heated in salt were enriched with nitrogen, selected specimens were analyzed by both the wet method for combined nitrogen (as nitrides) and the vacuum fusion method for total nitrogen (as nitrides, as molecular nitrogen in holes, and in solution). The results are tabulated below in Table III; each value is the average nitrogen content of the cross section of a finished Charpy specimen.

TABLE III

Nitrogen Analyses of "C" Steel After Various Heat Treatments

<u>Heat Treatment</u>	<u>Combined Nitrogen*</u>	<u>Total Nitrogen**</u>	<u>Source</u>
As-Received	--- 0.017	0.0098 ---	Bureau of Ships Commercial Laboratory
Heated in air at 1100°F for 112 hours and air cooled	0.015 ---	--- 0.0104	Commercial Laboratory Republic Steel Corp.
Heated in nitrate salt at 1100°F for 112 hours and furnace cooled	0.126	---	Commercial Laboratory
Heated in nitrate salt at 1100°F for 112 hours and water quenched	--- 0.106	0.1120 ---	Republic Steel Corp. Commercial Laboratory

*Wet Method

**Vacuum fusion method

Both methods of analysis show that the nitrogen content of specimens subcritically heated in air at 1100°F for 112 hours and air cooled is essentially the same as the as-received plate; however, with specimens comparably heat treated in the nitrate salt, the nitrogen content is greatly increased over that of the as-received plate. The wet method indicates that the combined nitrogen content of the furnace cooled series is increased by a factor of about seven, and of the water quenched series by a factor of about six. The greater combined nitrogen content of the furnace cooled specimens indicates that an appreciable amount of nitrogen has been retained in solution in the water quenched series. The total nitrogen content of the water quenched series was increased by a factor of about eleven after the nitrate salt treatment.

It should be noted that for both the as-received and air heated conditions the combined nitrogen value is greater than the comparable total nitrogen value. This is hardly possible and, undoubtedly, the wet method employed for combined nitrogen is in error. Therefore, all values obtained by this method have no numerical significance other than to show the relative nitrogen contents.

X-Rays--In order to identify the structure of the nitrogen compounds, several x-ray patterns were made of specimens which had been heat treated in the nitrate salt at 1100°F for 112 hours and furnace cooled. Samples about 0.020 inch square and

1/2 inch long were cut from the edge and the core of impact specimens, and Debye patterns made from both positions, using monochromatic $\text{CoK}\alpha$ radiation. Exposure times of 40 hours or more at 45 KV and 7ma were required to show up the nitrogen compounds.

The specimen from the core showed a weak pattern with the presence of Fe_4N being indicated, while the specimen from the rim revealed a stronger pattern with both Fe_3N and Fe_4N being indicated. The short plates in the microstructure can now be labeled the Fe_4N phase, and the long plates, the Fe_3N phase.

Patterns made of air cooled and also water quenched specimens failed to disclose the presence of a new phase.

Source of Nitrogen--The increase in nitrogen content after the heat treatment in nitrate salt suggested two possible reasons: (1) a preferential oxidation of the iron, thus decreasing the amount of metal without the loss of any nitrogen, and (2) an enrichment with nitrogen by a scaling reaction of the specimens with the salt, allowing the nitrogen to diffuse into the metal.

Reason 1 was considered possible in view of the fact that after long times in the salt bath, specimens were badly scaled. The scale was multi-layered and of a compressive nature. The extent of metal loss was determined for impact specimens sub-critically heated in salt and in air at 1100°F for 112 hours,

by breaking off the scale, wire brushing and then determining the cross sectional area loss. The loss in area after heat treatment in air was 1/2 per cent, and 5 1/2 per cent after treatment in salt. Although the metal loss was high for the salt heat treatment, a calculation shows that it could only account for an increase in nitrogen from 0.0098 per cent to 0.010 per cent, if the nitrogen did not diffuse out; whereas, the analysis showed a total nitrogen content of 0.112 per cent.

Although this difference would seem to preclude Reason 1, attempts were made to duplicate the structure by different heat treatments in an oxygen atmosphere. In this manner nitrogen bearing media such as air and nitrate salt could be excluded. The heat treatments employed are listed in Table IV.

TABLE IV

Heat Treatments in Oxygen Atmosphere

<u>Temperature</u>	<u>Time</u>	<u>Cooling Rate</u>	<u>Cross Sectional Area Loss, Per Cent</u>
1830°F	21 hours	Furnace Cool from 1100°F	18 1/2
1830°F	21 hours	Air Cool	18

Although the scaling loss was greater for both specimens than any of the salt heat treatments, a microscopic examination failed to reveal the presence of either of the nitride phases.

Both specimens were then wrapped in copper and soaked in an air furnace at 1100°F for 112 hours and furnace cooled.

Again, the microscopic evidence was negative.

A still further check was made by removing nitrogen from impact specimens by vacuum heating to 2200°F in 100°F steps from 1600°F after outgassing. The pressure at the start was 0.5×10^{-4} mm but with each increase in temperature the pressure built up to 3 to 6 times this initial value and then subsequently decreased to $0.5\text{--}0.7 \times 10^{-4}$ mm Hg. This was carried out over a two day interval and the nitrogen content was then assumed to be nil. Subsequent heat treatment at 1100°F for 112 hours in nitrate salt and in air, employing a furnace cool, definitely showed the presence of the nitride structure in the salt treated specimen, Fig. 8a and not in the air heated specimen, Fig. 8b.

As a check on the contamination of the salt bath and also on the possibility that the electrical circuit was contributing a catalytic effect, one as-received sample of "C" steel was placed in a small crucible containing used salt, and another in new salt. The crucibles were then placed in a small heavy-duty furnace at 1100°F for 112 hours, and furnace cooled. The resulting microstructures of the two samples showed the presence of nitride needles in the specimen heated in the old salt but not in the specimen in the new salt. The specimen in the new salt was then further heated at 1100°F for 96 more hours and furnace cooled. The microstructure now revealed the presence of nitrides. Apparently the nitrate

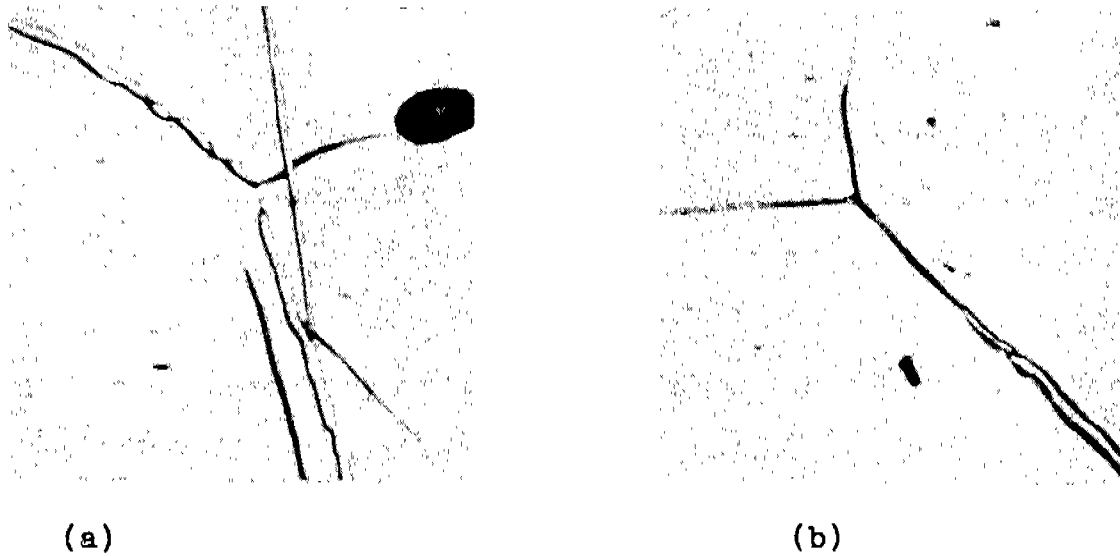

Fig. 8: MICROSTRUCTURES OF "C" STEEL AT 2000X AFTER FOLLOWING HEAT TREATMENTS:

- (a) 2200°F in vacuum and furnace cooled, followed by subcritical heat treatment at 1100°F in nitrate salt for 112 hours and furnace cooled.
- (b) Same as (a) except subcritical heat treatment was carried out in air.

salt had decomposed to react with the steel and introduce nitrogen.

All these experiments served to establish that the enrichment with nitrogen was brought about by a reaction of the specimens with the nitrate salt, resulting in a diffusion of nitrogen into the steel and not a nitrogen build-up by preferential oxidation of the iron.

SUMMARY

The observation of anomalous transition behavior between "C" steel subcritically heated in air and in nitrate salt led to an investigation of the cause of embrittlement when this steel is heat treated in nitrate salt.

The embrittlement was followed by both Charpy V-notch impact and eccentric notch tensile tests after subcritical heat treatment in the 700°--1100°F range for various times. Three different cooling rates were employed--air cool, furnace cool, and water quench.

The embrittlement was found to increase with subcritical temperature, time at temperature, and cooling rate after an initial incubation period.

Metallographic studies, X-rays, and nitrogen analyses show that the embrittling agent is nitrogen introduced by a scaling reaction of the steel with the nitrate salt used as the heating medium.

The embrittlement due to nitrogen pick up is superimposed on any embrittlement resulting from subcritical heat treatment carried out in air.